

## Experiment No: 1

## Diode Characteristics

**Objective:** To study and verify the functionality of a) **PN junction** diode in forward bias

b) **Point-Contact** diode in reverse bias

### Components/ Equipments Required:

Sl.No.	Components		Equipments	
	Name	Quantity	Name	Quantity
1	Diode (BY127, OA79)	1(One) No each	DC Regulated Power supply (0 - 30 V variable)	1(One) No.
2	Resistor (1K $\Omega$ )	1(One) No.	Digital Ammeters ( 0 - 200 mA, 0 - 200 $\mu$ A)	1(One) No. Each
3	Bread board	1(One) No.	Digital Voltmeter (0 - 20V)	1(One) No.
4	Connecting wires (Single strand, Multi strand)			

### Biasing of PN junction Diode:

#### Forward bias operation

The P-N junction supports uni-directional current flow. If +ve terminal of the input supply is connected to P-side and -ve terminal is connected to the n side, then diode is said to be forward biased condition. In this condition the height of the potential barrier at the junction is lowered by an amount equal to given forward biasing voltage. Both the holes from p-side and electrons from n-side cross the junction simultaneously thereby decreasing the depleted region. This constitutes a forward current (majority carrier movement – diffusion current). Assuming current flowing through the diode to be very large, the diode can be approximated as short-circuited switch. Diode offers a very small resistance called **forward resistance (few ohms)**

#### Reverse bias operation

If negative terminal of the input supply is connected to p-side and -ve terminal is connected to n-side then the diode is said to be reverse biased. In this condition an amount equal to reverse biasing voltage increases the height of the potential barrier at the junction. Both the holes on P-side and electrons on N-side tend to move away from the junction there by increasing the depleted region. However the process cannot continue indefinitely, thus a small current called reverse saturation current continues to flow in the diode. This current is negligible; the diode can be approximated as an open circuited switch it offers a very high resistance called **reverse resistance(few Kiloohms)**.

**Static Resistance:** The opposition offered by a diode to the direct current flowing forward bias condition is known as its **DC forward resistance** or Static Resistance. It is measured by taking the ratio of DC voltage across the diode to the DC current flowing through it at an operating point.

**Dynamic Resistance:** The opposition offered by a diode to the changing current flow I forward bias condition is known as its **AC Forward Resistance**. It is measured by a ratio of change in voltage across the diode to the resulting change in current through it for an operating point P.

**Average Resistance:** Same as dynamic resistance but measured between extremities.

### Diode current equation

The volt-ampere characteristics of a diode explained by the following equations:

$$I = I_0(e^{V/\eta V_T} - 1)$$

Where I = current flowing in the diode,

$I_0$  = reverse saturation current

$V$  = voltage applied to the diode,

$V_T$  = volt- equivalent of temperature =  $k T/q = T/ 11,600 = 26\text{mV}$  (@ room temp)

$\eta = 1$  (for Ge) and 2 (for Si)

**Circuit Diagram:**

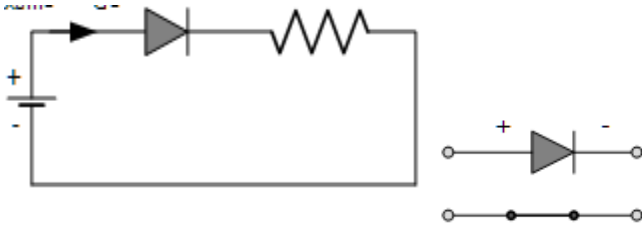

**Fig. 1: Forward Bias Condition**

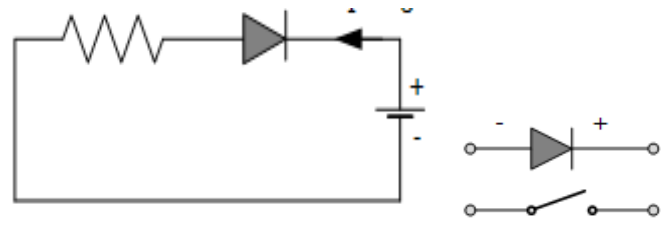

**Fig. 2: Reverse Bias Condition**

**Procedure: (a) Forward Bias Condition:**

1. Connect the circuit as shown in Fig.1 (PN Junction diode with milli-ammeter in series with the diode).
2. Initially vary Regulated Power Supply (RPS) voltage  $V_s$  in steps of **0.1 V**. Once the current starts increasing vary  $V_s$  in steps of **0.02V** and note down the corresponding readings  $V_f$  and  $I_f$ .
3. Tabulate different forward currents obtained for different forward voltages.
4. Plot the V-I characteristics and calculate the resistance levels
5. Compare the theoretical and practical values (cut-in voltage and resistances).

**Tabular column:**

Forward bias		Reverse bias	
$V_D(\text{volts})$	$I_D (\text{ mA})$	$V_D(\text{volts})$	$I_D (\text{ } \mu\text{A})$

**(b) Reverse Bias Condition:**

1. Connect the circuit as shown in Fig.2 (Point contact diode in series with micro ammeter).
2. Vary  $V_s$  in the Regulated Power Supply (RPS) gradually in steps of **1V** from **0V** to **12V** and note down the corresponding readings  $V_r$  and  $I_r$ .

3. Tabulate different reverse currents obtained for different reverse voltages.
4. Plot the V-I characteristics and calculate the resistance levels
5. Compare the theoretical and practical values.

### Ideal characteristics

#### Forward Characteristic

#### Reverse Characteristic

### Calculations from Graph:

#### a) Forward Bias of PN Junction Diode:

Cut-in Voltage  $V_{\gamma} =$

Static forward Resistance  $R_{dc} = V_f / I_f \Omega$

Dynamic Forward Resistance  $r_{ac} = \Delta V_f / \Delta I_f \Omega$

Average Resistance  $r_{avg} = \Delta V_f / \Delta I_f \Omega$  / pt to pt

#### b) Reverse Bias of Point contact diode:

Similarly find static and dynamic resistances

**Result:** Volt-Ampere Characteristics of P-N Diode are studied.

### Application of Diode;

**Outcomes:** Students are able to

1. Analyze the characteristics of PN diode.
2. Calculate the resistance in forward bias and reverse bias.

## Experiment No: 2 Common Emitter Configuration Characteristics

**Objective:** To study the input and output characteristics of a transistor (Common Emitter configuration).

### Component/ Equipment required:

Component		Equipment		
Sl. No.	Name	Quantity	Name	Quantity
1	Transistor-npn BC 107	1(One) No.	DC Regulated Power supply (0 - 30 V)	2 (One) No.
2	Resistors (1K $\Omega$ , 100K $\Omega$ )	1(One) No. Each	Digital Ammeters (0 - 200 mA, 0-200 $\mu$ A)	1(One) No. Each
3	Bread board	1(One) No.	Digital Voltmeter (0 - 20V)	2(Two) No.
4	Connecting wires (Single Strand)			

**Specifications:** For Transistor BC 107: Max Collector Current = 0.1A;  $V_{CEO\ max} = 50V$

### Circuit Diagram:

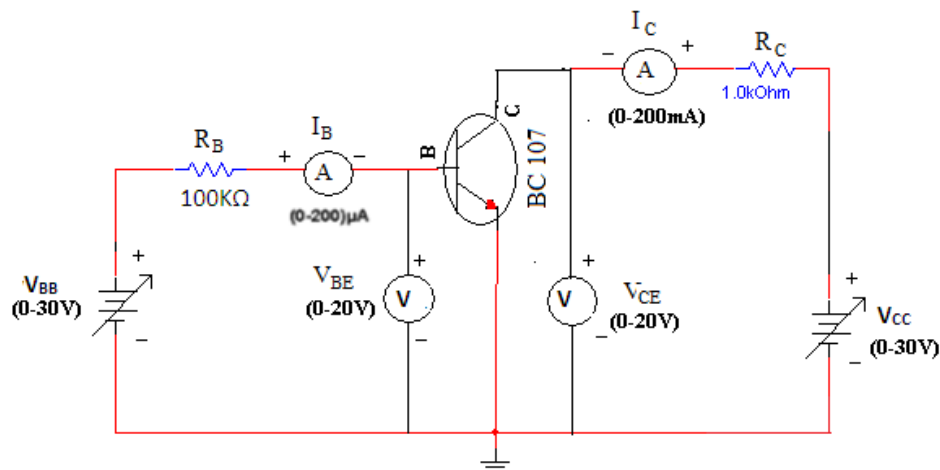
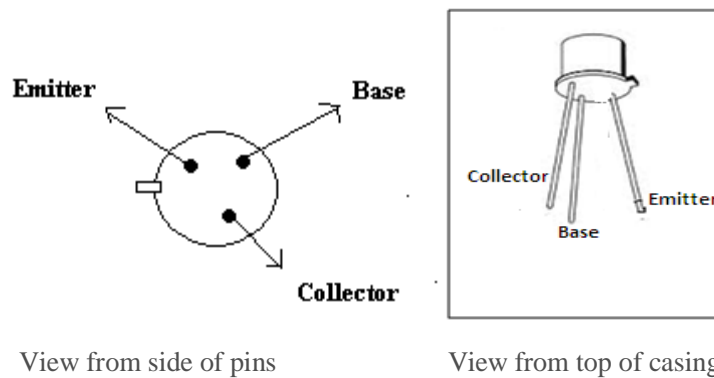

Fig. 1: Common emitter circuit.

### Pin assignment of Transistor:



### Operation:

The input is applied between base and emitter, the output is taken between collector and emitter. Input characteristics are obtained between the input current  $I_B$  and input voltage  $V_{BE}$  at constant output voltage  $V_{CE}$ . This portion of an NPN BJT is just like a p-n junction. Consequently, the  $I_B$  and  $V_{BE}$  relationship in the

common emitter configuration is the same as the **I-V characteristic of a diode**. The typical value of  $V_{BE}$  for a silicon BJT is 0.7 V.

Output characteristics are obtained between the output voltage  $V_{CE}$  and output current  $I_C$  at constant input current  $I_B$ . The output **I-V characteristic** consists of a set of curves, one for each value of  $I_B$ . In the common emitter configuration, all the I-V curves start from  $I_C = 0$  and  $V_{CE}$  equal to some threshold value. For a given value of  $I_B$ , the curve increases steeply until it reaches a level proportional to  $I_B$ , at which point it flattens (but not completely).

**Procedure: (a) Input Characteristics:**

1. Connect the circuit as shown in the circuit diagram.
2. Keep output voltage  $V_{CE} = 0V$  by varying  $V_{CC}$ .
3. Varying  $V_{BB}$  gradually, note down base current  $I_B$  and base-emitter voltage  $V_{BE}$ .
4. Step size is not fixed because of non linear curve. Initially vary  $V_{BB}$  in steps of 0.1V. Once the current starts increasing vary  $V_{BB}$  in steps of 0.1V.
5. Repeat above procedure (step 3) for  $V_{CE} = 2V$  and 5V.
6. Plot the input characteristics:  $V_{BE}$  on X-axis and  $I_B$  on Y-axis at a constant  $V_{CE}$  as a constant parameter.

$V_{CE} = 0\text{ V}$		$V_{CE} = 2\text{ V}$		$V_{CE} = 5\text{ V}$	
$V_{BE}(\text{volts})$	$I_B (\mu\text{A})$	$V_{BE}(\text{volts})$	$I_B (\mu\text{A})$	$V_{BE}(\text{volts})$	$I_B (\mu\text{A})$

**(b) Output Characteristics:**

1. Connect the circuit as shown in the circuit diagram.
2. Keep emitter current  $I_B = 20\mu\text{A}$  by varying  $V_{BB}$ .
3. Varying  $V_{CC}$  (1V up to 12V), note down collector current  $I_C$  and Collector-Emitter Voltage( $V_{CE}$ ).
4. Repeat above procedure (step 3) for  $I_B = 40\mu\text{A}$  and  $60\mu\text{A}$ .
5. Plot the output characteristics:  $V_{CE}$  on X-axis and taking  $I_C$  on Y-axis taking  $I_B$  as a constant parameter.

**Tabular column:**

$I_B = 20 \mu A$		$I_B = 40 \mu A$		$I_B = 60 \mu A$	
$V_{CE}$ (volts)	$I_C$ (mA)	$V_{CE}$ (volts)	$I_C$ (mA)	$V_{CE}$ (volts)	$I_C$ (mA)

**Graph:**

**Ideal Input Characteristics**

**Ideal Output Characteristics**

**Calculations from Graph:**

1. **Input Characteristics:** Input impedance =  $R_i = \Delta V_{BE} / \Delta I_B$  ( $V_{CE}$  is constant)
2. **Output Characteristics:** Output admittance =  $\Delta I_C / \Delta V_{CE}$  ( $I_B$  is constant)
3. **Forward current gain**  $\beta = \Delta I_C / \Delta I_B$  ( $V_{CE} = \text{constant}$ )

**Result:** Input and Output characteristics of a Transistor in Common Emitter Configuration are studied.

Application of **BJT**:

**Outcomes:** Students are able to

1. Analyze the characteristics of BJT in Common Emitter and configuration.
2. Calculate h-parameters from the characteristics obtained.

## Experiment No:3

## Diode Clipper

**Objective:** To study and verify the functionality of PN junction diode as series and shunt clippers.

**Component/ Equipment required:**

Sl. No.	Component		Equipment	
	Name	Quantity	Name	Quantity
1	Diode (BY127)	2 No.	DC Regulated Power supply (0 - 30 V)	1(One) No.
2	Resistors	1(One) No. Each	Oscilloscope	1(One) No. Each
3	Bread board	1(One) No.	Function generator	2(Two) No.
4	Connecting wires (Single Strand)			

**Theory:** There are two general categories of clippers::series and parallel. The series configuration is defined as one where the diode is in series with the load, while the parallel variety has the diode in a branch parallel to the load. Depending on the orientation of the diode, the positive or negative region of the input signal is “clipped”off.

### Circuits: Series clippers

Input

Circuit

Output

Transfer Characteristics

1)

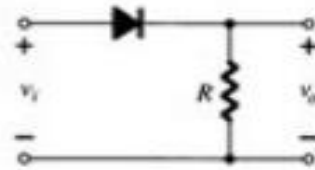

2)

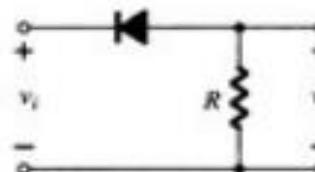

3)

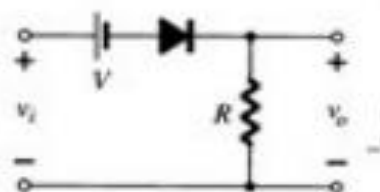

4)

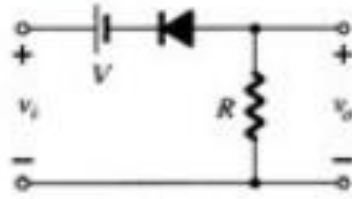

5)

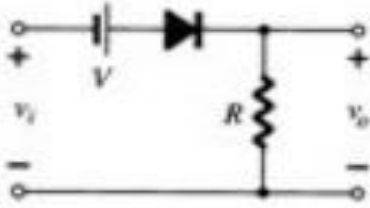

6)

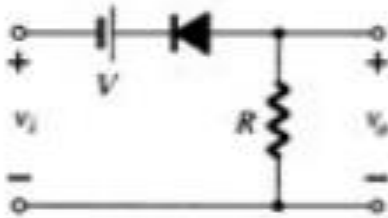

### Circuits: Shunt clippers

7)

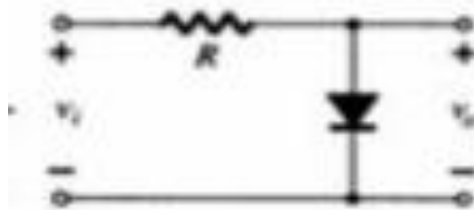



8)

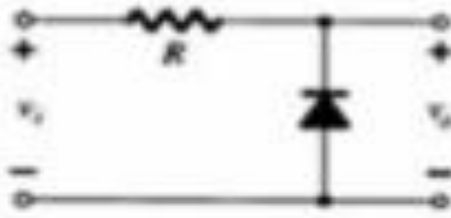

9)

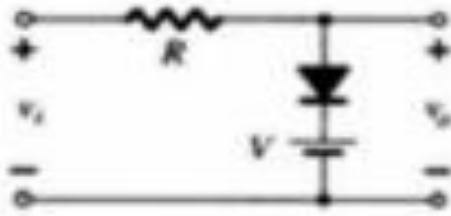

10)

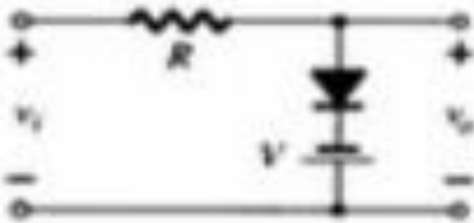

11)

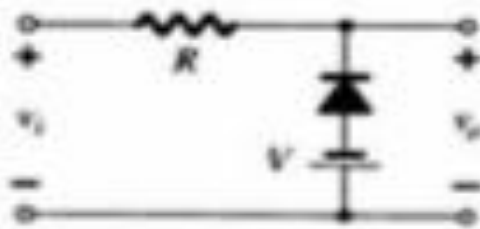

12)

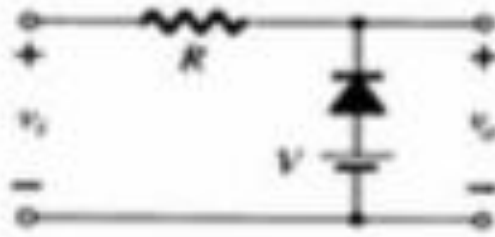

**Circuits: Double Ended clipper**

13)

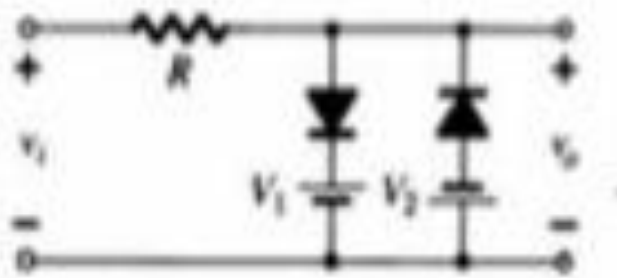

**Note: Try Two level clippers**

**Procedure:**

- 1) Connect the circuit as shown in Fig. 1
- 2) Apply input 1KHz sinewave of peak to peak value of 12V.
- 3) Observe the output waveform on CRO.
- 4) Observe the transfer characteristics by pressing the X-Y key of CRO
- 5) Plot the wave forms and the transfer characteristics.
- 6) Repeat the same procedure for the remaining 12 circuits as in Fig.2 to Fig. 13
- 7) For circuit with DC supply, choose appropriate value.

## Experiment No: 4

# VOLTAGE REGULATORS

**Objective:** Part A: To design and test a simple Zener Voltage Regulator

**Component/ Equipment required:**

Sl. No.	Component		Equipment	
	Name	Quantity	Name	Quantity
1	Zener Diode	1(One) No.	Dual DC Regulated Power supply (0 - 30 V)	1(One) No.
2	IC-Voltage Regulator 7805	1(One) No. Each	Digital Ammeters (0 -1A)	1(One) No.
3	0-50Ω POT Resistor	1(One) No.	Multimeter	1(One) No.
4	Connecting wires (Single Strand)			

**Theory:**

Zener diode is a P-N junction diode specially designed to operate in the reverse biased mode. It is acting as normal diode while forward biasing. It has a particular voltage known as break down voltage, at which the diode break downs while reverse biased. In the case of normal diodes the diode damages at the break down voltage. But Zener diode is specially designed to operate in the reverse breakdown region.

Zener breakdown: When a diode is heavily doped, it's depletion region will be narrow. When a high reverse voltage is applied across the junction, there will be very strong electric field at the junction. The electron hole pair generation takes place and heavy current flows.

Breakdown: There is a limit for the reverse voltage can increase until the diode breakdown voltage reaches. This point is called Avalanche Breakdown region. At this stage maximum current will flow through the zener diode. This breakdown point is referred as “Zener voltage”.

The function of a regulator is to provide a constant output voltage to a load connected in parallel with it in spite of the ripples in the supply voltage or the variation in the load current. The zener diode will continue to regulate the voltage until the diodes current falls below the minimum  $I_{Z(MIN)}$  value in the reverse breakdown region. It permits current to flow in the forward direction as normal, but will also allow it to flow in the reverse direction when the voltage is above a certain value - the breakdown voltage known as the Zener voltage. In breakdown the voltage across the Zener diode is close to constant over a wide range of currents thus making it useful as a shunt voltage regulator.

**CIRCUIT DIAGRAM:**

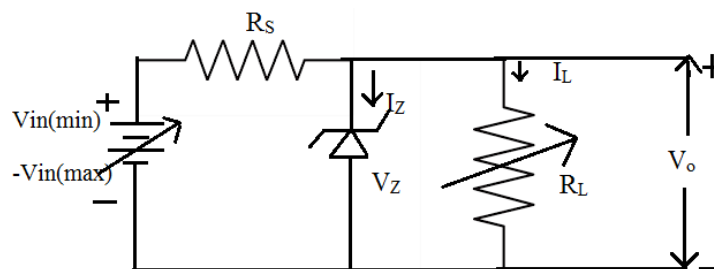

Fig 1: Simple Voltage Regulator Using Zener Diodes

## Design:

A typical Zener diode shunt regulator is shown in Fig.1. The resistor is selected so that when the input voltage is at  $V_{IN(min)}$  and the load current is at  $I_{L(max)}$  that the current through the Zener diode is at least  $I_{Z(min)}$ . A Zener diode of break down voltage  $V_Z$  is reverse connected to an input voltage source  $V_i$  across a load resistance  $R_L$  and a series resistor  $R_S$ . The voltage across the Zener will remain steady at its break down voltage  $V_Z$  for all the values of Zener current  $I_Z$  as long as the current remains in the break down region. Hence a regulated DC output voltage  $V_0 = V_Z$  is obtained across  $R_L$ .

With the input voltage is at  $V_{in (min)}$  & Load Current at  $I_{L(MAX)}$ , current through the series resistance  $R_S$

$$I = I_{max} + I_{Z (min)}$$

The voltage across  $R_S$ ,

$$V_{RS} = V_{IN (max)} - V_Z$$

Therefore

$$R_S = V_{RS} / I = V_{IN (min)} - V_Z / I_{L max} + I_{Z min}$$

Select the nearest standard value for  $R_S$

The Maximum input voltage at which the regulator is effective is given by

$$V_{IN(max)} = V_{IN(min)} + I R_S$$

Thus, the regulation is effective only between  $V_{IN (min)}$  and  $V_{In (max)}$

Design the Zener Voltage Regulator for the following specifications:

$$V_{in (min)} = 12v$$

$$V_0 = 5.6v$$

$$I_L = 5mA \text{ to } 30mA \text{ (Variable)}$$

## Procedure:

Basically there are two type of regulations such as:

**a) Line Regulation:** Series resistance and load resistance are fixed, only input voltage is changing. Output voltage remains the same as long as the input voltage is above a minimum value ( $V_Z + 2\text{ V}$ ).

**b) Load Regulation:** Input voltage is fixed and the load resistance is varying. Output volt remains same, as long as the load resistance is maintained above a minimum value (As per the design).

## Line Regulation:

1. Make the circuit connections as shown in Fig.1.
2. With  $V_{IN} = (V_Z + 2\text{ V})$ , adjust  $R_L$  so that  $I_L = I_{L\text{ MAX}} = 30\text{ mA}$  (as per specification)
3. Vary  $V_{IN}$  starting from  $V_{IN(\text{min})} = 0\text{ V}$  to  $V_{IN(\text{max})} = 18\text{ V}$  in steps of 1v,
4. Note down the value of  $V_O$  at each step. Tabulate the readings.
4. Plot a graph of  $V_O$  vs  $V_{IN}$

**Table 1**

$I_L = I_{L\text{ MAX}} = \quad \text{mA}$		$V_{IN} = (V_Z + 2\text{ V})$	
$V_{IN}(\text{v})$	$V_O(\text{v})$	$I_L(\text{mA})$	$V_O(\text{v})$
0		0	$V_{O,\text{NO LOAD}}$
18v		$I_{L\text{ MAX}}$	$V_{O,\text{FULL LOAD}}$

## **Graph:**

Ideal characteristics: Line Regulation

Ideal characteristics: Loa Regulation

$$\% \text{line Regulation} = \Delta V_O / \Delta V_{IN} * 100\% = \Delta V_O / (18-12)v * 100\%$$

### Load Regulation:

1. Make circuit connections as shown in Fig.1
2. Adjust  $V_{IN} = (V_Z + 2 \text{ V})$ .
3. Vary  $I_L$  from 0 to  $I_{L(\text{max})}$  by varying  $R_L$  from  $R_{L(\text{max})}$  to  $R_{L(\text{min})}$
4. Note down the corresponding values of  $V_O$ . Tabulate the readings.
4. Plot a graph of  $V_O$  vs  $I_L$

$$\% \text{ Load Regulation} = (V_O \text{ No load} - V_O \text{ full load} / V_O \text{ full load}) * 100\%$$

### Result:

Voltage Regulator using Zener diode was designed and constructed and the characteristics were plotted.

1. The regulated output voltage was found to be-----V
2. Line regulation was found to be -----
3. Load regulation was found to be -----

Application of Zener Diode:

### Part B: 7805 IC VOLTAGE REGULATOR (+5V OUTPUT)

**THEORY:**A voltage regulator is a voltage stabilizer that is designed to automatically stabilize a constant voltage level. A voltage regulator circuit is also used to change or stabilize the voltage level according to the necessity of the circuit. Thus, a voltage regulator is used for two reasons:-

1. To regulate or vary the output voltage of the circuit.
2. To keep the output voltage constant at the desired value in-spite of variations in the supply voltage or in the load current.

### CIRCUIT DIAGRAM

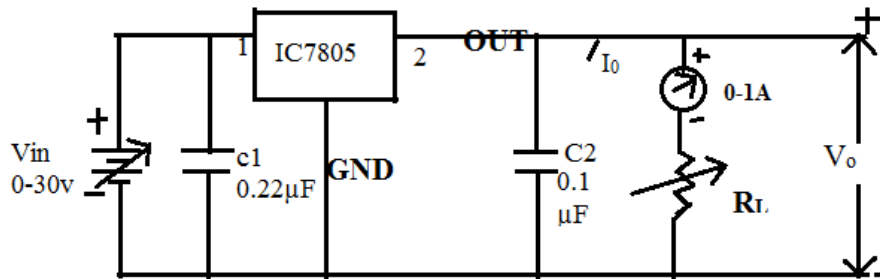

Fig.2: IC Regulator

**Procedure:**

1. Make circuit connections as shown in Fig 2
2. Adjust the input voltage to minimum of 5V drop out voltage of 7805
3. Adjust  $I_L = 0.1A$  [ $R_L = 50\Omega$ ]
4. Vary the input voltage  $V_{IN}$  from 0V to 20V in steps and record the values of output voltage in Table.2.
5. Plot a graph of  $V_O$  vs  $V_{IN}$

**Table 2**

$V_{IN}(V)$	$V_O(V)$	$R_L$	$I_L(A)$	$V_O(V)$
7	$V_{O(MIN)}$	Open (infinity)	0	$V_{O,NO\ LOAD}$
8		50	0.1A	
9		25	0.2A	
20	$V_{O(MAX)}$	5	$I_L(max)$	$V_{O,FULL\ LOAD}$

**Graph:**

Ideal characteristics: Line Regulation

Ideal characteristics: Load Regulation

$$\% \text{line Regulation} = \Delta V_O / \Delta V_{IN} * 100\% = \Delta V_O / (18-12)\text{V} * 100\%$$

## LOAD REGULATION:

1. Make the circuit connections as shown in Fig.2
2. Set  $V_{IN}$  at minimum i.e,  $V_{IN} = 5\text{V}$  drop out voltage and keep it constant
3. Vary output from 0A to 100mA in steps using the  $50\Omega$  POT
4. Note down the corresponding values of  $V_O$ .
4. Also note down the open-circuit output voltage  $V_{O, NO\ LOAD}$  (i.e output with  $R_L$  open or  $R_L = \text{infinity}$  )
5. Tabulate the readings in Table 2.2
5. Determine the percentage load regulation.

$$\% \text{ Load Regulation} = (V_O \text{ no load} - V_O \text{ full load} / V_O \text{ full load}) * 100\%$$

## RESULT:

The Voltage Regulator using IC7805 was designed and constructed and the characteristics were plotted.

1. The regulated output voltage was found to be-----V
2. Line regulation was found to be -----
3. Load regulation was found to be -----

Application of IC regulator

Outcomes:



**Objective: To design and test Op-Amp as an amplifier and an arithmetic operator**

**Theory:** An operational amplifier (Op-amp) is an integrated circuit (IC) that operates as a voltage amplifier. These amplifiers are called "operation" amplifiers because they were initially designed as an effective device for performing arithmetic operations (like addition, subtraction, and etc.,) in an analog circuit. An op-amp has a differential input (two inputs of opposite polarity). An op-amp has a single output and a very high gain.

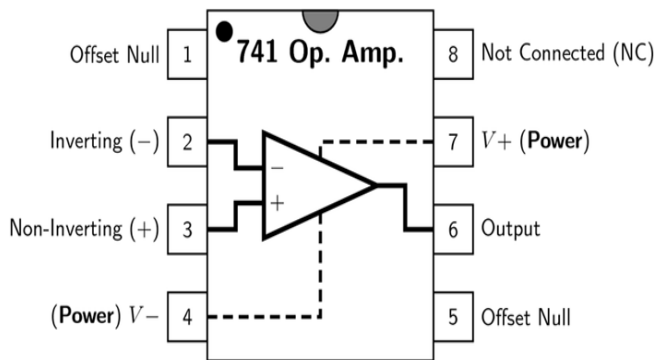

**Fig. 1: IC- $\mu$ A741**

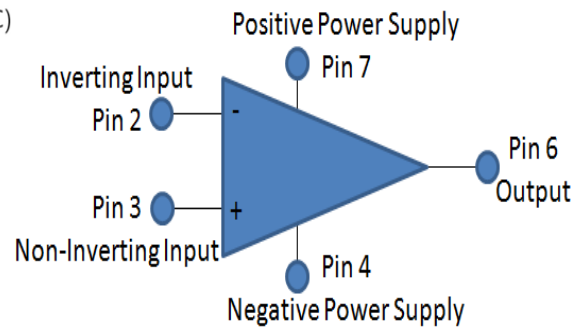
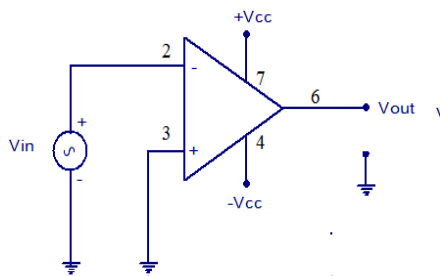

**Fig.2: Symbolic Representation of Op-Amp**

There are 8 pins in a common Op-Amp(741) as shown in Fig.1. An Op-Amp is often depicted as shown in Fig.2. The gain of the Op-Amp itself is calculated as  $A_v = V_{out}/(V_{in})$

The maximum output is the power supply voltage, Ideally Open-loop gain  $G$  is typically over 9000, but closed-loop gain is much smaller,  $R_{in}$  is very large ( $M\Omega$  or larger) and  $R_{out}$  is small ( $75\Omega$  or smaller)

**Zero Crossing Detector (ZCD):** The zero crossing detector circuit as shown in Fig 3 is used to test the Op-Amp device.



**Fig. 3: Zero Crossing Detector Circuit**

**Input-Output waveform**

**(a) Op-Amp as inverting Amplifier:** The input waveform will be amplified by the factor  $A_v$  (through the input resistance  $R_1$  and  $R_f$  is the feedback resistor) in magnitude and its phase will be inverted. In the inverting amplifier circuit the signal to be amplified is applied to the inverting input of the Op-amp. Inverting operational amplifier gain can be expressed using the equation  $A_v = - R_f / R_1$ .

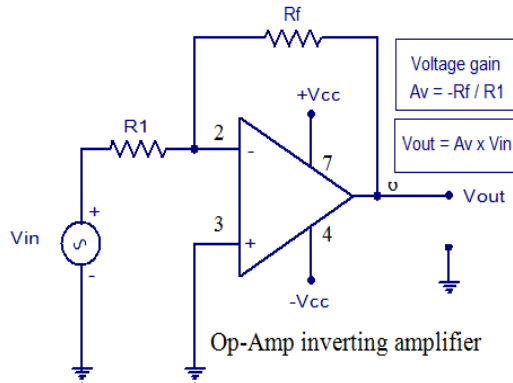

**Fig.4: Inverting Amplifier circuit**

**Input-Output waveform**

**Procedure:**

1. Connect the circuit as shown in Fig.4.
2. Apply the supply voltages of +15V to pin 7, -15V pin 4 and ground to pin 3 of IC741.
3. Apply the inputs  $V_{in}$  as shown (DC/AC ) to the input.
4. Vary the input voltages and note down the corresponding output at pin 6.
5. Tabulate reading as shown in Table 1.
6. Calculate the gain and compare with the theoretical gain.
7. Repeat same procedure for non-inverting amplifier of Fig 5.

Table 1

	Inverting amplifier		Non-inverting amplifier	
$V_{in}$ in Volts	$V_o$ (theoretical) in volts	$V_o$ (practical) in volts	$V_o$ (theoretical) in volts	$V_o$ (practical) in volts

**(b) Non-Inverting Amplifier:** Output directly linked to the inverting input and applying the input signal to the non-inverting input as shown in Fig.5. The voltage gain of this circuit is given by the expression

$$A_V = 1 + (R_f / R_1).$$

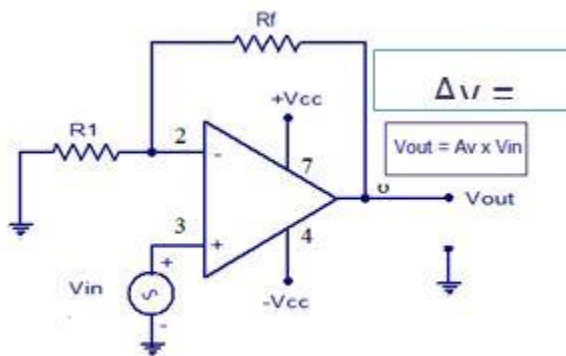

**Fig.5: Non-Inverting Amplifier circuit**

**Input-Output waveform**

**(c) Op-Amp Adder Circuit:** The inputs are applied through resistors to the inverting terminal and non-inverting terminal is grounded. This is called “virtual ground”, i.e. the voltage at that terminal is zero. The gain of this summing amplifier is 1, any scale factor can be used for the inputs by selecting proper external resistors. The output voltage  $V_o = - ( V_1 + V_2 )$

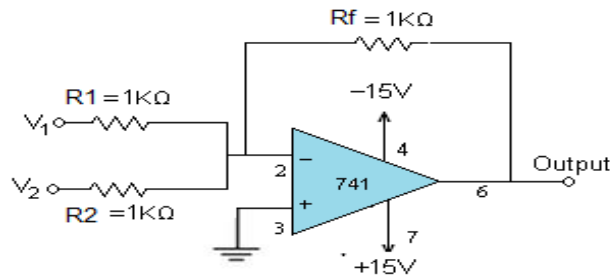

**Fig.5: Op-Amp as adder circuit**

**Procedure:**

3. Connect the circuit as shown in Fig. 5.
4. Apply the supply voltages of +15V to pin7, -15V pin4 and ground to pin 3 of IC741.
3. Apply the inputs  $V_1$  and  $V_2$  as shown (DC/AC ) to the inputs.
4. Vary the input voltages and note down the corresponding output at pin 6.
5. Notice that the output is equal to the sum of the two inputs  $V_o = - ( V_1 + V_2 )$ .

**Table 2**

		Adder		Subtractor	
$V_1$ in Volts	$V_2$ in Volts	$V_o$ (theoretical) in volts	$V_o$ (practical) in volts	$V_o$ (theoretical) in volts	$V_o$ (practical) in volts

**(d) Subtractor Circuit:** The output voltage  $V_o$  is equal to the voltage applied to the non-inverting terminal minus the voltage applied to the inverting terminal; hence the circuit is called a Subtractor.

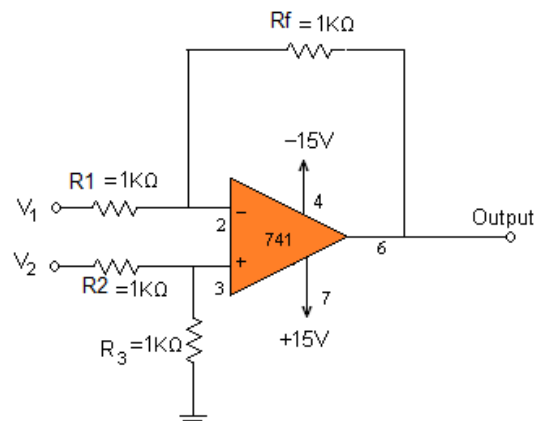

**Fig.6: Op-Amp as Subtractor circuit.**

**Procedure:**

1. Connect the circuit as shown in Fig.6.
2. Apply the supply voltages of +15V to pin7,-15V pin4 and ground to pin 3 of IC741.
3. Apply the inputs  $V_1$  and  $V_2$ . (DC/AC ) to the inputs.
4. Vary the input voltages and note down the corresponding output at pin 6 of the IC 741
5. Notice that the output is equal to the difference of the two inputs  $V_o = V_2 - V_1$ .

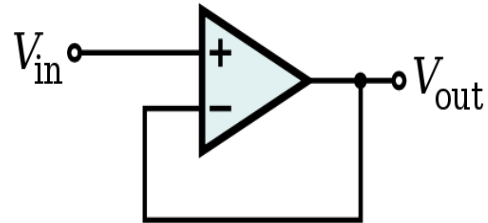

**Fig 7:Op-Amp Buffer**

$$V_{out} = V_{in}$$

Buffer isolates loading effects

**Conclusion:** compare theoretical and practical values