

Experiment No

Aim: To determine **Regulation and Efficiency** of a single phase transformer by **open circuit (O.C.) and short circuit (S.C.) tests**

Apparatus: -

Single phase transformer
Single phase dimmer stat
Ammeter (AC)
Voltmeter (AC)
Multi-function meter

THEORY: -Open Circuit Test:

The main purpose of this test is to find the iron loss and no load current which are useful in calculating core loss resistance and magnetizing reactance of the transformer.

In O.C. test primary winding is connected to a.c. supply, keeping secondary open. Sometimes a voltmeter may be connected across secondary as voltmeter resistance is very high & voltmeter current is negligibly small so that secondary is treated as open circuit. Usually low voltage side is used as primary and high voltage side as secondary to conduct O.C. test.

When primary voltage is adjusted to its rated value with the help of variac, readings of ammeter and wattmeter are to be recorded.

Ammeter gives no load current. Transformer no load current is always very small, 2 to 5 % of its full load current.

As secondary is open, $I_2 = 0$, hence secondary copper losses are zero. And $I_1 = I_0$ is very low hence copper losses on primary are also very low. Thus the total copper losses in O.C. test are negligibly small, hence neglected.

Therefore the wattmeter reading in O.C. test gives iron losses which remain constant for all the loads.

Short Circuit Test:

The main purpose of this test is to find full load copper loss and winding parameters (R_{01} & X_{01} or R_{02} & X_{02}) which are helpful for finding regulation of transformer.

Experiments for First Year Electrical Engg Lab 2015-16

In this test, secondary is short circuited with the help of ammeter. (secondary may be short circuited with thick copper wire or solid link). As secondary is shorted, its resistance is very very small and on rated voltage it may draw very large current. Such large current can cause overheating and burning of the transformer. **To limit this short circuit current, primary is supplied with low/reduced voltage (5 - 15% of the rated voltage) which is just enough to cause rated current to flow through primary which can be observed on an ammeter.** The reduced voltage can be adjusted with the help of variac. The wattmeter reading as well as voltmeter, ammeter readings are recorded.

As the voltage applied is low which is a small fraction of the rated voltage and iron losses are function of applied voltage, hence iron losses are negligibly small. Since the currents flowing through the windings are rated currents hence the total copper loss is full load copper loss. Hence the wattmeter reading is the power loss which is equal to full load copper losses.

Procedure: **A) O.C. test:**

1. Connect the circuit as shown in circuit diagram.
2. Switch on the supply after checking connection by concerned teacher.
3. Increase the input voltage to the transformer winding upto rated value (230V) slowly using dimmer stat.
4. Measure the primary voltage, primary current, primary circuit power and secondary voltage of transformer.
5. Reduce the voltage slowly using variac.
6. Switch off the supply and remove connections.

Procedure: **B) S.C. test: (Do not switch on supply yourself.)**

1. Connect the circuit as shown in circuit diagram.
2. **Switch on the supply after checking connection by concerned teacher.**
3. Increase the input voltage very **CAREFULLY** and **SLOWLY** so that the current in secondary winding reaches rated value (8.6A) using dimmer stat.
4. Measure the primary voltage, primary current, primary circuit power and secondary current of transformer.
5. Reduce the voltage slowly using dimmer stat.
6. Switch off the supply and remove connections.

Experiments for First Year Electrical Engg Lab 2015-16

Precaution:

- 1) Do not put on the supply until the circuit is checked by concerned teacher.
- 2) Do not touch any live part of circuit.
- 3) Be careful for primary & secondary winding rated current.

Result & Conclusion:

Discussion Questions

1. What is regulation and efficiency of a transformer?
2. Why is core made from silicon steel alloy and not ordinary steel?
3. Why the core is made from thin laminations and not a solid steel core?
4. Why core losses remain almost constant at any load?
5. What are the advantages and disadvantages of direct loading method over open circuit and short circuit test?
6. Justify-open circuit test gives core losses while short circuit test gives copper losses.
7. Discuss the effect of output power on efficiency and regulation.
8. Why reduced voltage is required for s.c. test?
9. Why s.c. test is generally performed with L.V. side short circuited?
10. Why o.c. test is generally performed on L.V. side.

On LHS by Hand with Pencil

EXPERIMENT NO.

Aim: To determine **Regulation and Efficiency** of a single phase transformer by **open circuit (o.c.) and short circuit (s.c.) tests**

Apparatus:

Sr. No.	Name of Apparatus	Range/Rating	Make
1	Single phase dimmer stat		
2	Ammeter (AC)		
3	Voltmeter (AC)		
4	1-phase Transformer		
5	Multi-function meter		

Circuit Diagram : open circuit (o.c.) Test

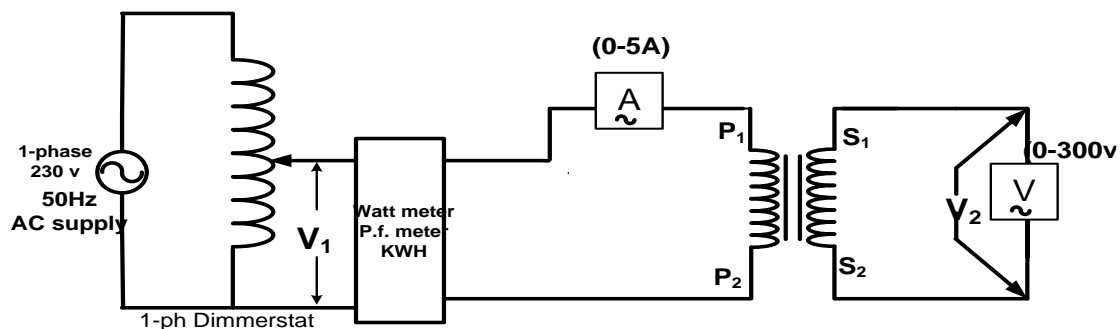

Circuit Diagram : short circuit (s.c.) Test

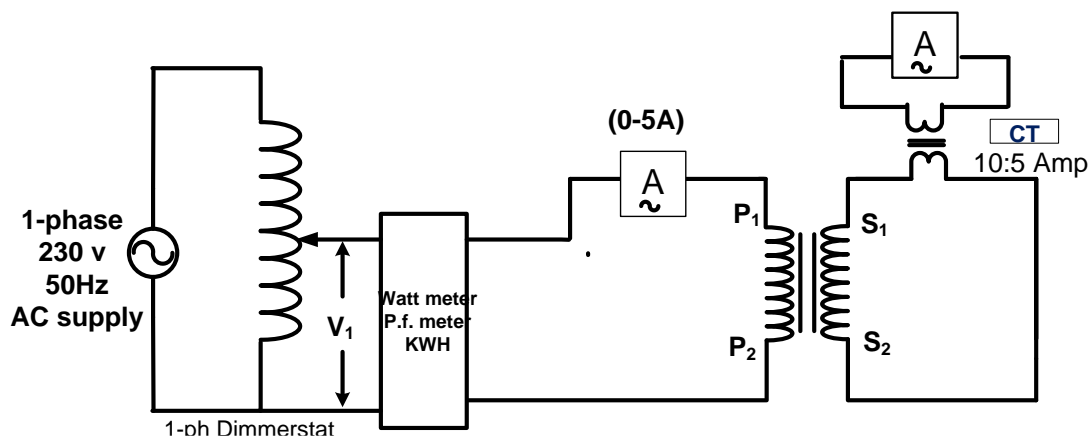

On LHS by Hand with Pencil

Observation table for open circuit (o.c.) test:-

Sr. No.	Primary rated Voltage V_1 (volts)	No-load current I_0 (Amp)	Wattmeter reading (Iron loss) W_0 (Watts)	Secondary Induced Voltage V_2 (Volts)
1				

Observation table for short circuit (s.c.) test:-

Sr. No.	Primary Voltage V_{sc} (volts)	Primary current I_{1sc} (Amp)	Secondary current I_{2sc} (Amp)	Wattmeter reading W_{sc} (F.L. copper loss) (Watts)
1				

On LHS by Hand with Pencil

Calculations:

From O.C. Test :

$$\cos \phi_0 = \frac{W_0}{V_1 I_0} \qquad I_w = I_o \cos \phi_0 \qquad I_m = I_o \sin \phi_0$$

$$R_0 = \frac{V_1}{I_0 \cos \phi_0} ; \qquad X_0 = \frac{V_1}{I_0 \sin \phi_0}$$

From S.C. Test :

$$R_{sc} = \frac{W_{sc}}{I_1^2 sc} \qquad Z_{sc} = \frac{V_{sc}}{I_1 sc} \qquad X_{sc} = \sqrt{Z_{sc}^2 - R_{sc}^2}$$

$$R_{01} = R_{sc} \qquad X_{01} = X_{sc}$$

$$\% \text{ Efficiency} = \frac{KVA \text{ rating} \times 10^3 \times p.f.}{KVA \text{ rating} \times 10^3 \times p.f. + W_{cu} + W_i} \times 100 \qquad \text{p.f.} - \text{load power factor}$$

$$\% \text{ Regulation} = \frac{I_1 [R_{01} \cos \phi + X_{01} \sin \phi]}{V_1} \times 100$$

Calculate efficiency & regulation at following load power factor-

1. At unity p.f.
2. At 0.8 p.f. lagging
3. At 0.8 p.f. leading

On LHS by Hand with Pencil

Equivalent Circuit Diagram from o.c. Test

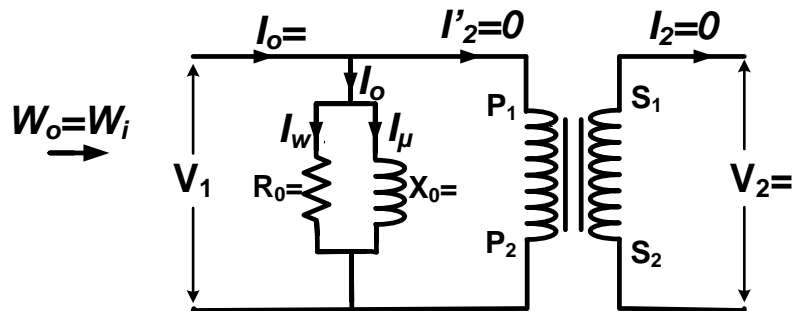

Equivalent Circuit Diagram from s.c. Test

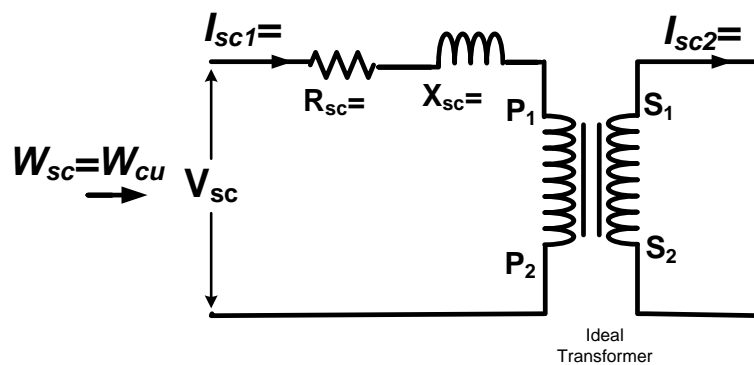

EXPERIMENT NO.

Aim: To determine **Regulation and Efficiency** of a single phase Transformer by **direct loading test**.

Apparatus: -

Single phase dimmer stat, Ammeter (AC), Voltmeter (AC)
Single phase transformer, Wattmeter, Resistive Load Bank

Theory:

This method of calculation of efficiency and regulation of a transformer is entirely different from the determination of efficiency and regulation by o.c. and s.c. test on transformer.

In this method secondary of transformer is connected to load. When secondary is loaded, the secondary current I_2 is set up. The magnitude and phase of I_2 with respect to terminal voltage V_2 depends on the type of load (If load is resistive then I_2 will be in phase with V_2 , for inductive load I_2 will lag behind V_2 and for capacitive load it will lead the voltage V_2).

Because of this secondary current I_2 , there is a drop in terminal voltage V_2 . Drop in voltage depends on the impedance of load & p.f.

For leading p.f. voltage drop may be negative and for lagging p.f. it is always positive.

Since the flux passing through the core is same from no load to full load conditions, core losses remain same and since the copper losses depend on the square of the current, they vary with the current.

Regulation is defined as the ratio of change in terminal voltage from no load to full load to the no load voltage.

$$\text{Regulation} = \frac{V_2(\text{no load}) - V_2(\text{full load})}{V_2(\text{no load})}$$

Regulation can be found out at any p.f. and at any load current.

Efficiency is defined as the ratio of output power to the input power of the transformer. Efficiency of a transformer varies with power factor at different loads.

$$\eta = \frac{\text{output}}{\text{input}} = \frac{V_2 I_2 \cos \phi}{V_2 I_2 \cos \phi + W_i + W_{cu}}$$

Experiments for First Year Electrical Engg Lab 2015-16

$\cos \phi = 1$ for resistive load. W_i = iron loss, W_{cu} = copper loss.

Procedure: -

- 1) Make the connections as shown in diagram.
- 2) Keep all the switches of loading rheostat in off position and variac at zero position.
- 3) Switch on the supply.
- 4) Apply 230 V to the primary winding.
- 5) Note down secondary voltage (V_{2NL}) where V_{NL} - No load voltage.
- 6) Switch on the load and note down all meter readings correctly.
- 7) Go on increasing the load till the rated secondary current flows up to 8.6 Amp.

Precaution:

- 1) Do not put on the supply until the circuit is checked by concerned teacher.
- 2) Do not touch any live part of circuit.
- 3) Be careful for primary & secondary winding rated current .

Graphs :

- 1) Output power vs. efficiency
- 2) Output power vs. regulation.

Result & Conclusion:

Discussion questions:

- 1) What is regulation and efficiency of a transformer?
- 2) What are the ranges of efficiency and regulation of a transformer in ideal and practical condition?
- 3) Why core losses remain almost constant at any load?
- 4) What is the condition for maximum efficiency? Derive it.
- 5) Why wattmeter is not used to measure the secondary power or output power in direct loading test?
- 6) What are the advantages and disadvantages of direct loading method over open circuit (o.c.) and short circuit (s.c.) test?
- 7) What will happen if the efficiency of a transformer is poor? Explain in terms of losses, loading capacity and cooling requirements.
- 8) What will happen if the regulation of a transformer is poor? Have you experienced the effect of poor regulation, if yes when and where?

On LHS by Hand with Pencil

Aim: To determine Regulation and Efficiency of a single phase Transformer by direct loading test.

Apparatus:

Sr. No.	Name of Apparatus	Range/Rating	Make
1	Single phase dimmer stat		
2	Ammeter (AC)		
3	Voltmeter (AC)		
4	1-phase Transformer		
5	Multi-function meter		
6	Resistive Load Bank		

Circuit diagram:-

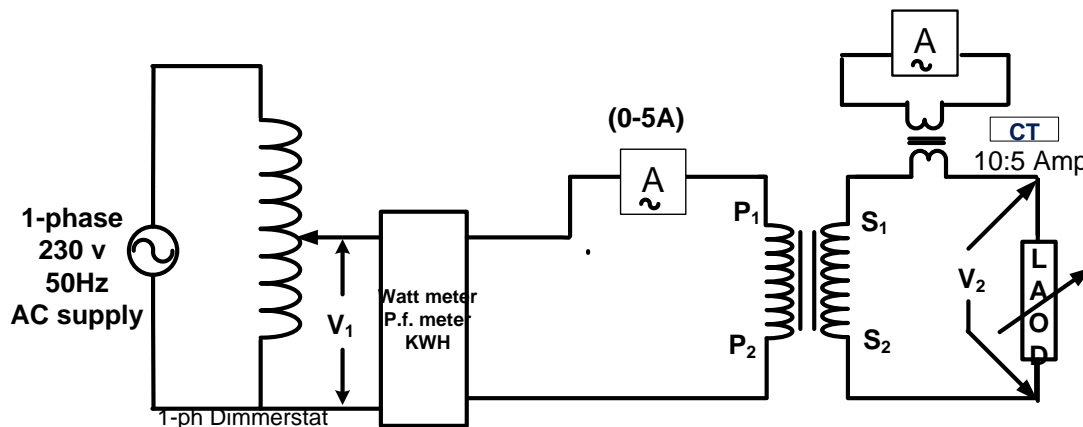

Experiments for First Year Electrical Engg Lab 2015-16

Observation table :-

Sr. No.	Primary voltage	Primary current	Watt-meter reading	Secondary Voltage	Secondary current	Secondary power	% Efficiency	% Regulation
	V_1	I_1	W_1	V_2	I_2	$W_2 = V_2 I_2$	$\% \eta = \frac{W_2}{W_1} \times 100$	$\% \text{Regu} = \frac{V_{2NL} - V_{2L}}{V_{2NL}} \times 100$
1	230 volts constant				0			
2								
3								
4								
5								
6								
7								
8								
9						8.6		

EXPERIMENT NO.

Aim: To study the balanced three phase system for star & delta connected load.

Apparatus: -

Three phase dimmer stat, Ammeter (AC), Voltmeter (AC)
multi-function meter , rheostats (3-number)

THEORY:-

Any three phase system, either supply system or load can be connected in two ways either star or delta.

(i) **Star Connection**→ In this connection, the starting or termination ends of all winding are connected together & along with their phase ends this common point is also brought out called as neutral point.

(ii) **Delta Connection**- If the terminating end of one winding is connected to starting end of other & If connection are continued for all their windings in this fashion we get closed loop. The three supply lines are taken out from three junctions. This is called as three phase delta connected system.

The load can be connected in similar manner. In this experiment we are concerned with balanced load.

The load is said to be balanced when

i. Voltages across three phases are equal & phases are displaced by 120° electrical.

ii. The impedance of each phase of load is same.

iii. The resulting current in all the three phases are equal & displaced by 120° electrical from each other

iv. Active power & reactive volt amperes of each is equal.

Some term related to 3 ph system

i. **Line Voltage** - The voltage between any two line of 3 ph load is called as line voltage e.g. V_{RY}, V_{YB} & V_{BR} . For balance system all are equal in magnitude.

ii. **Line Current** - The current in each line is called as line current e.g. $I_R, I_Y,$ & I_B . They are equal in magnitude for balance system.

iii. **Phase Voltage** - The voltage across any branch of three phase load is called as phase voltage. $V_{RN}, V_{YN},$ & V_{BN} are phase voltage

Experiments for First Year Electrical Engg Lab 2015-16

iv. Phase **Current** - current passing through any phase of load is called as phase current.

For star connection of load-

Line voltage (V_L) = $\sqrt{3}$ phase voltage (V_{ph})

Line current (I_L) = Phase current (I_{ph})

For delta connection of load-

Line voltage (V_L) = phase voltage (V_{ph})

Line current (I_L) = $\sqrt{3}$ phase current (I_{ph})

The three phase power is given by,

P = power consumed by the load = $\sqrt{3} V_L I_L \cos(\phi)$

Where ϕ is phase angle & it depends on type of load i.e. inductive, capacitive or resistive.

Procedure:

- i. Connect circuit as shown in the circuit diagram
- ii. Set demerstat to minimum position.
- iii. Switch on the main supply
- iv. Note the readings of ammeter, voltmeter & multifunction meter.
- v. Note more readings by changing supply voltage.

Result & conclusion:

Discussion questions: -

1. What are the advantages of 3 phase system over single phase system?
2. In case of balanced load, is there any necessity of neutral wire? Why?
3. What should be the consumer load? Star or delta connected? Why?
4. What do you mean by phase sequence of three phase system?
5. If same resistance which were connected in star are connected in delta, what will be the power consumed?
6. Show that for star connection, $V_L = \sqrt{3} V_{ph}$ & for delta connection $I_L = \sqrt{3} I_{ph}$.
7. With diagram, show how the 3-phase, 4 wire supply from MSEDCL can be distributed to supply power to a 3 story building having one flat on each floor.

On LHS by Hand with Pencil

EXPERIMENT NO.

Aim: To study the balanced three phase system for star & delta connected load.

Apparatus: -

Sr. No.	Name of Apparatus	Range/Rating	Make
1	Three phase dimmer stat		
2	Ammeter (AC)		
3	Voltmeter (AC)		
4	Rheostats		
5	Multi-function meter		

Circuit Diagram: A) For star connected load:

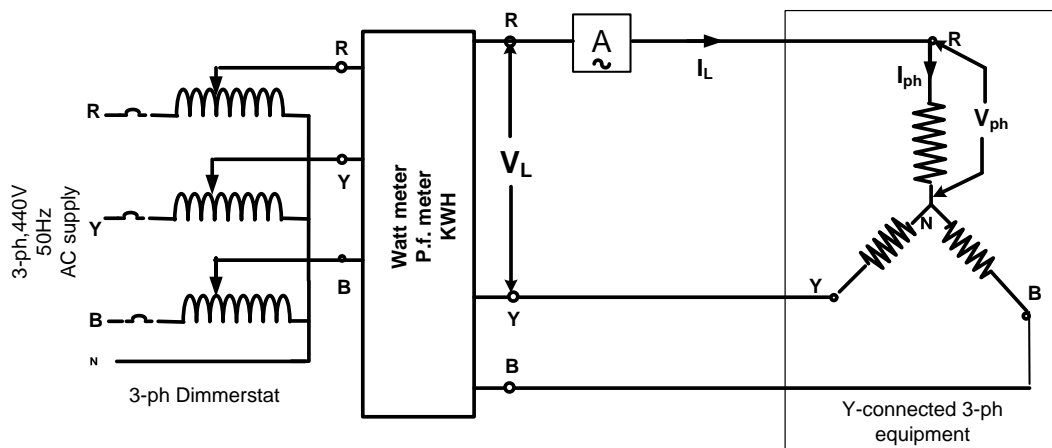

Observation table:- For Star connected load:

Sr No	Line Voltage V_L (volts)	Phase Voltage V_{ph} (volts)	Phase current I_{ph} (Amp)	Ratio of V_L/ V_{ph}	Power by calculation $W= \sqrt{3}V_L I_L \cos(\theta)$ (watts)
1					
2					

On LHS by Hand with Pencil

Circuit Diagram: B) For Delta connected load:

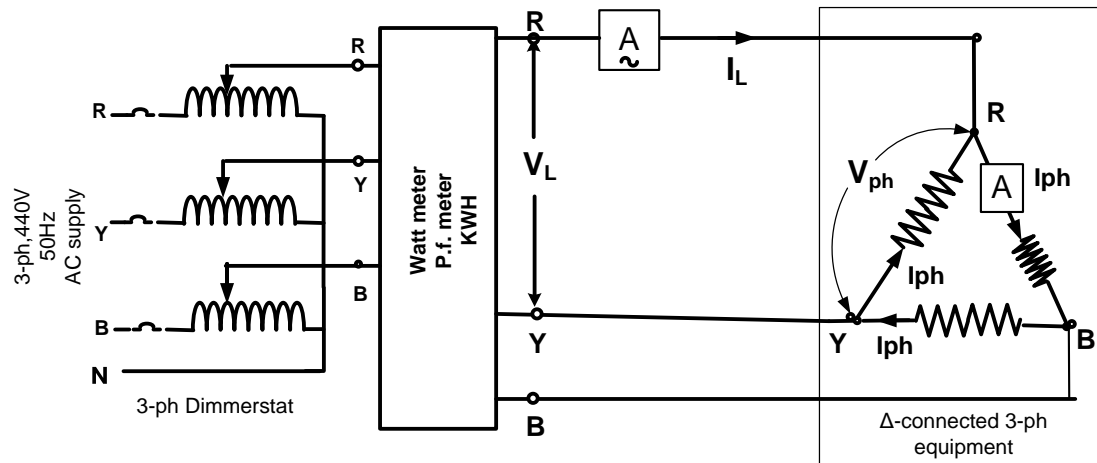

Observation table: - For Delta connected load:

Sr No	Line Voltage V_L (volts)	Line Current I_L (Amp)	Phase current I_{ph} (Amp)	Ratio of I_L / I_{ph}	Power by calculation $W = \sqrt{3} V_L I_L \cos(\theta)$ (watts)
1					
2					
3					

Phasor diagram:

➤ Draw phasor diagrams for star and delta connected load.

EXPERIMENT NO-

Aim: -Improvement of the power factor by using static capacitor.

Apparatus:

Single phase dimmerstat, resistor, inductive coil, capacitor bank, voltmeters, ammeters, multi function meter.

Theory: -

All electrical loads which operate by means of electro-magnetic field effects, such as motors, transformers, fluorescent lighting etc, basically consumes two types of power namely- **active power & re-active power**.

The active power is the power that is used by the load to meet the functional output i.e. the **ACTIVE** power performs the useful work whereas the **REACTIVE** power is the power that is used by the load to meet its magnetic field requirements as well as to provide the magnetic losses. Phasor sum of these two power is the power generated by alternators in volt-ampere which is known as **apparent power**. **Fig1** is known as power triangle.

Three sides of power triangle are-Active power= $V \cdot I \cos(\phi)$

Re-active power= $V \cdot I \sin(\phi)$

Apperent power= $V \cdot I$

With the help of power triangle, **power factor** of an **AC** electrical network/load is defined as the ratio of the active power (real power) flowing to the load to the apparent power in the circuit and is a dimensionless number between **0 and 1**.

Power Factor is a measure of how efficiently electrical power is consumed.

Causes of low power factor: Normally load power factor is of lagging nature due to highly inductive loads. This induction is caused by equipment such as lightly loaded electric motors, transformers, arc lamps, welding equipments and fluorescent lighting ballasts, etc.

Low power factor means over loading the generators, transformers, cables etc. Hence increase in current and copper losses as well as reduction in life of these equipments .Low power factor also causes poor voltage regulation.

Capacitor bank for power-factor improvement-

Loads with low power factor can be improve with a static capacitors.

Improving the power factor means reducing the angle of lag between supply voltage and current.

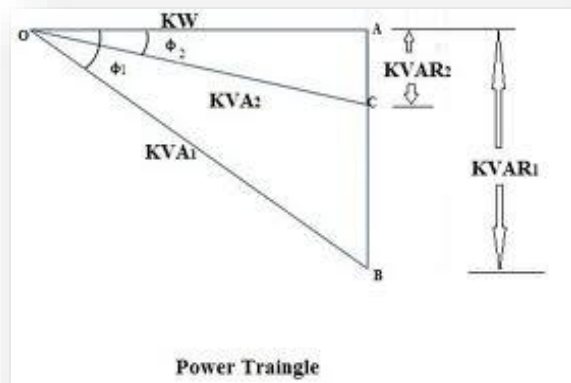

FIG.1

Capacitors are the most cost effective and reliable static devices that can generate and supply re-active power. Capacitors consume virtually negligible active power and are able to produce reactive power, thus known as power factor corrector.

Essentially, power factor is a measurement of how effectively electrical power is being used. The higher the power factor, the more effectively electrical power is being used.

Procedure:-

- Make the connections as shown in the circuit diagram.
- Set variac to zero output.
- Set both rheostats at maximum position.**
- Adjust the variac to give a **150V voltage** to the circuit without capacitor in circuit.
- Adjust the inductive coil to give 0.6 p.f. lagging in the p.f. meter.**
- Note down the voltage across R, L, C, & I_s , I_R , I_L & I_C & power factor meter reading without capacitor in circuit.

Experiments for First Year Electrical Engg Lab 2015-16

g) Take different readings for different values of capacitors in circuit & notedown voltages, currents & p.f.meter reading in circuit.

h) Plot the graphs-
i) VAr V^s p.f
ii) VAr V^s Source current I_s
iii) VAr V^s cable loss ($I_s^2 R_s$)

Precaution: Put ON and OFF capacitor bank switches slowly/carefully.

Result & Conclusion:-

Discussion Questions:-

1. What is power factor?
2. What is active power, re-active power, and apparent power? Write equations of it.
3. What is power triangle?
4. What are the disadvantages of low power factor?
5. Name the apparatus (electrical gadgets) that have poor power factor.
6. Why efficiency of supply system is less with low power factor?
7. What is the range of power factor allowed by power companies (MSEDCL) for industrial loads? Why?
8. What action is taken if power factor is less than or exceeds this range?

Experiments for First Year Electrical Engg Lab 2015-16

On LHS by Hand with Pencil

EXPERIMENT NO.

Aim: Improvement of the power factor by using static capacitor.

Apparatus:

Sr. No.	Name of Apparatus	Range/Rating	Make
1	Single phase dimmer stat		
2	Ammeter (AC)		
3	Voltmeter (AC)		
4	Rheostats		
5	Inductor		
6	Capacitor bank		
7	Multi-function meter		

Observation Table

Sr. No.	V_s	I_s	I_R	I_L	I_c	$V_L=V_c$	$PF=\cos \phi$	Nature of p.f. (lag/lead)

Calculation Table:

Sr. No.	VAr (CAPACITIVE) =VcIc	LOSS IN SUPPLY CABLE= $I_s^2 R_s$	APPERENT POWER =Vsls	ACTIVE POWER =Vsls × cos φ	REACTIVE POWER =Vsls × sin φ

Experiments for First Year Electrical Engg Lab 2015-16

Circuit Diagram :

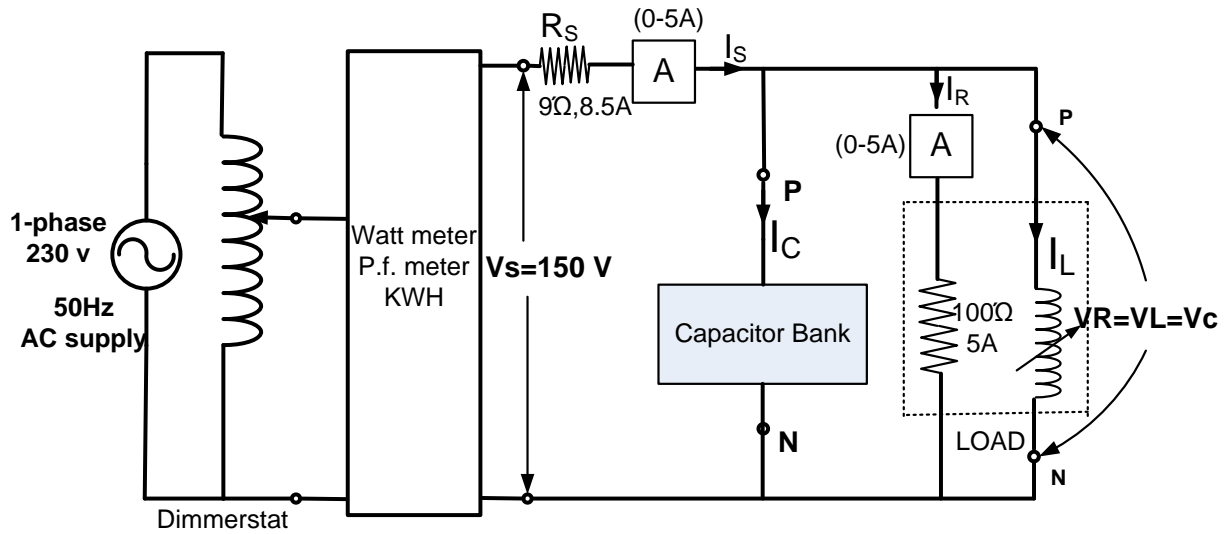

Capacitor Bank

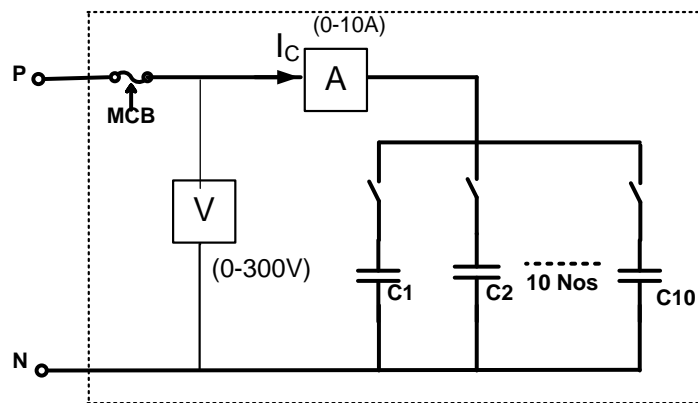

- Graphs-**
- i) VAr V^s p.f
 - ii) VAr V^s Source current I_s
 - iii) VAr vs cable loss ($I_s^2 R_s$)

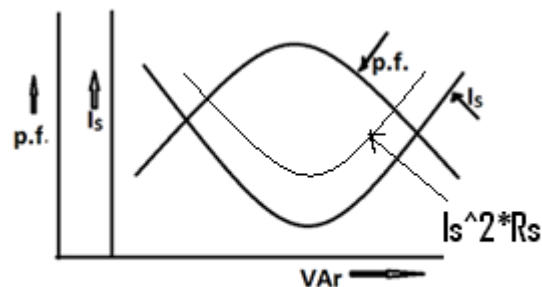

EXPERIMENT NO.

Aim: To find out the Luminous Efficacy and Polar curve of a Light Source.

Theory:

Candela, Lumen, Lux: the equations

Light is measured with different techniques, and therefore there is a handful of related, but different, units of measurements. This article gives a brief overview of the most widely used measures and presents [a few equations](#) for conversion of one measure into another.

Candela: The candela (unit cd) has its origin in the brightness of a "standard candle", but it has received a more precise definition in the International System of Units (SI) —and at that time the unit was also renamed from "candle" to "candela".

The candela measures the amount of light emitted in the range of a (three-dimensional) angular span. Since the luminous intensity is described in terms of an angle, the distance at which you measure this intensity is irrelevant. For ease of illustration, in the picture at the right the three dimensions have been flattened to two. In this picture, screen B would catch exactly the same amount of light rays (emitted from the light source) as screen A —provided that screen A were removed to not obscure screen B. This is because screen B covers the same angle as screen A.

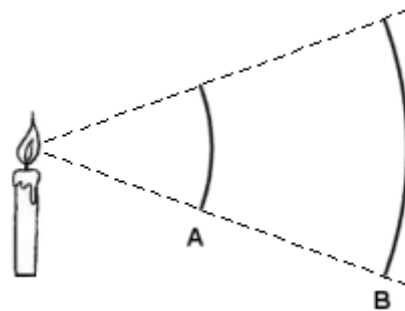

The angular span for candela is expressed in steradian, a measure without unit (like radian for angles in a two-dimensional space). One steradian on a sphere with a radius of one metre gives a surface of one m^2 . A full sphere measures 4π steradians.

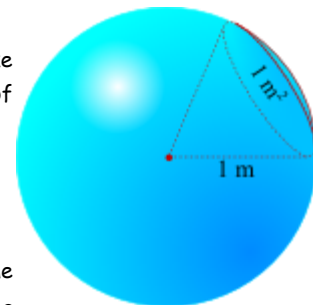

Lumen: If you look at LEDs, especially high-brightness LEDs, you may notice that the LEDs with a high luminous intensity (in candela or milli-candela, mcd) typically have a narrow [apex angle](#). Similarly, LEDs with a wide [apex angle](#) typically have a relatively low luminous intensity. The same is true for halogen spots with reflector: those with a narrow-beam reflector have a higher rating in candela than the "floodlight" spots of the same power.

The cause for this relation is the total energy produced by the LED. LEDs of a specific class (for example, "high flux") all produce roughly the same amount of luminous energy. However, when a LED emits its total energy in a narrow angle, the intensity will be greater (in the direction of that angle) than when the same energy had been emitted over a wide angle.

The lumen (unit lm) gives the total luminous flux of a light source by multiplying the intensity (in candela) by the angular span over which the light is emitted. With the symbol Φ_v for lumen, I_v for candela and Ω for the angular span in steradian, the relation is $\Phi_v = I_v \cdot \Omega$

If a light source is isotropic (meaning: uniform in all directions), $\Phi_v = 4\pi I_v$. This is because a sphere measures 4π steradians.

Experiments for First Year Electrical Engg Lab 2015-16

Lux: Lux (unit lx) is a measure of illumination of a surface. Light meters often measure Lux values (or foot-candles, but these are directly related: one foot-candle is 10.764 lx). Formally, Lux is a derived unit from lumen, which is a derived unit from candela. Yet, the concept of Lux is more easily compared to candela than to lumen.

The difference between Lux and candela is that Lux measures the illumination of a surface, instead of that of an angle. The net result is that the distance of that surface from the light source becomes an important factor: the more distant that the surface is from the light source, the less it will be illuminated by it. In the picture at the right, screen A has the same size as screen B.

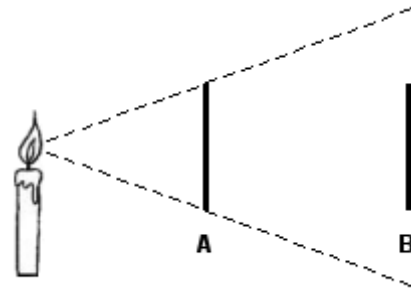

One steradian on a sphere with a diameter of one meter gives a surface of one m^2 . From this, it follows that at a measuring distance of 1 meter, the values for candela (lumen per steradian) and Lux (lumen per m^2) are the same. In general, measurements in Lux can be converted to and from candelas if the measurement distance is known. Note that when measuring LEDs, the virtual origin of the light source lies a few millimeters behind the physical point source because of the lens of the LED —this becomes relevant when measuring LEDs at a short distance.

Luminance: Luminance is a measure for the amount of light emitted from a surface (in a particular direction). The measure of luminance is most appropriate for flat diffuse surfaces that emit light evenly over the entire surface, such as a (computer) display. Luminance is a derived measure, expressed in Candela per square meter (cd/m^2). An alias for the unit cd/m^2 (unofficial, but still commonly used) is "Nit".

Luminance and illumination ("Lux") are related, in the sense that luminance is typically used for light-emitting surfaces and illumination for surfaces that are *being lit*. Assuming a perfect diffuse reflecting surface, you can multiply the measure in "Nits" by π to get the equivalent value in Lux. That is, with L_v for Luminance and E_v for Lux:

$$E_v = L_v \cdot \pi$$

As with Lux, there are several older units for luminance, of which the foot-lambert is probably the most common (because of its 1-to-1 relation with the foot-candle on a Lambertian-reflecting surface). These older units are easily converted to candela per square meter by multiplying them with a scale factor. For foot-lambert, the scale factor is 3.425.

Apex angle: Since the lumen and the candela measures are related through the viewing angle (or *apex angle*), it is useful to know how this angle is defined.

One measures the angle between the axis where the light source gives its highest luminous intensity and the axis where that intensity is reduced to 50%. In the picture at the right, this angle is denoted with θ . The apex angle is twice that angle (meaning 2θ).

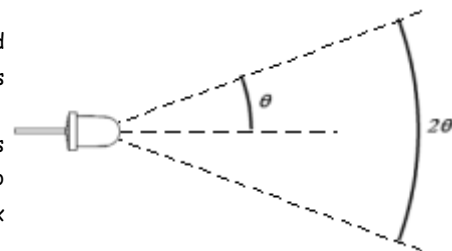

Observe that the reduction of intensity to 50% is based on a linear scale, but that our perception of brightness is *not* linear. The CIE has standardized the relation between luminous intensity and perceived brightness as a cubic root; other sources claim that a square root better approximates this relation.

The three-dimensional angular span for an apex angle, using Ω for the angular span (in steradian) and 2θ for the apex angle, is:

$$\Omega = 2\pi \left(1 - \cos \frac{2\theta}{2} \right)$$

Experiments for First Year Electrical Engg Lab 2015-16

Lighting efficiency: There are ample ways to illuminate a surface or a room: incandescent lamps, fluorescent tubes, LEDs, tungsten-halogen bulbs, electroluminescent sheets, and others. These are often compared in their efficiency of turning electrical energy to luminous energy.

The official name for lighting efficiency is "luminous efficacy of a source". This should not be confused with the "luminous efficacy of radiation", which disregards losses due to heat generation and others (and therefore gives significantly higher values). The lighting efficiency is measured in lm/W (lumen per Watt).

Lighting efficiency is often expressed as a percentage, based on the theoretical maximum value of lighting efficiency of 683.002 lm/W (at a wavelength of 555 nm). For example, at the time of this writing, a white 1 Watt "lumiled" can reach an efficiency of over 100 lm/W, giving an efficiency of 15%. While this may seem low, LEDs are actually quite efficient in comparison with other lighting methods.

From	To	Given	Equation
Candela (I_v)	Lumen (Φ_v)	apex angle α	$\Phi_v = 2\pi I_v \left(1 - \cos \frac{\alpha}{2}\right)$
Lumen (Φ_v)	Candela (I_v)	apex angle α	$I_v = \frac{\Phi_v}{2\pi(1 - \cos \frac{\alpha}{2})}$
Lumen (Φ_v)	Lux (E_v)	surface area A (m^2)	$E_v = \frac{\Phi_v}{A}$
Lux (E_v)	Lumen (Φ_v)	surface area A (m^2)	$\Phi_v = E_v \cdot A$
Candela (I_v)	Lux (E_v)	measuring distance D (m)	$E_v = \frac{I_v}{D^2}$
Lux (E_v)	Candela (I_v)	measuring distance D (m)	$I_v = E_v \cdot D^2$

Equations

Equipments used:

- Light Sources:
 - LED
 - Halogen
 - LED Bulb
 - CFL
 - Incandescent Bulb
- Multifunctional Energy Meter
- Lux Meter

Procedure:

1. Position the lamp mounted stand such that the lamp to be tested is facing the white board and exactly one meter from the board.
2. Make sure that the tube lights above the test area are off.
3. Start the source and then take 100 Lux readings with the Lux meter on the white board points marked A1 to J10. Make sure the readings are taken in a sequential manner and no shadow falls on the Lux meter.

Dept of Electrical Engineering,

Shri Ramdeobaba College of Engineering and Management, Nagpur 440013

INDIA

Page 23

Experiments for First Year Electrical Engg Lab 2015-16

A1	B1	C1	D1	E1	F1	G1	H1	I1	J1
A10	B10	C10	D10	E10	F10	G10	H10	I10	J10

4. Note the following readings from the MFD
 - a. Voltage , Current, Frequency
 - b. Watts (W), VAR, Power factor, VA
5. Note which coordinate has the highest Lux level in the readings.
6. Now position the lamp mounted stand perpendicular 2 meters away from the white board, with the same source facing the board. Measure the Lux level at the coordinate which had the highest Lux level noted above.

Light Source	Max Lux at 1 meter	Max Lux at 2 meter	Volts	Current	Frequency	W	VAR	Pf	VA

7. Start again from step 1 with another source.

Calculations:

- Enter the Lux values in an MS EXCEL Table. (sample given below)

A	B	C	D	E	F	G	H	I	J
271	284	403	519	491	444	397	340	292	282
263	319	427	558	624	514	501	420	328	274
294	368	448	556	743	715	796	506	377	305
311	400	446	579	706	726	870	532	389	322
321	405	433	525	595	765	836	555	392	332
296	386	394	477	535	592	608	498	370	307
267	340	348	408	455	489	485	417	330	278

Experiments for First Year Electrical Engg Lab 2015-16

235	287	290	342	365	371	402	351	287	246
200	239	245	275	295	306	321	287	237	213
165	184	222	221	234	244	273	222	196	174
155	171	200	201	210	215	240	201	180	163

- Select all cells and find out the average Lux level. **(AVG LUX)**
- Select all the cells and then plot a "Contour Chart". (Go to insert, select other charts, and the select Contour chart)
- You will get a Polar curve of the light source. (Sample given below)

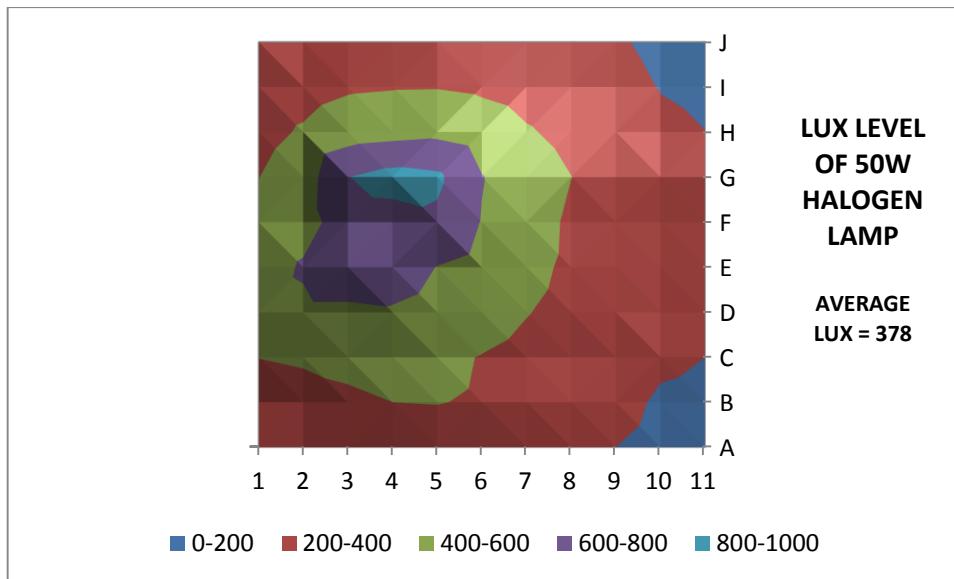

- Insert the lamp details and average Lux level.
- Do the following calculations for the luminous efficacy of the source.
 - Area selected is 1 sq.m
 - Lumens = Lux x Area. Take average value of Lux calculated.
 - Luminous efficacy = Lumens / watt = **AVG LUX / W**
- Repeat the above for various sources.
- Submit the result in the below mentioned manner:

Light source	Max Lux at 1 meter	Max Lux at 2 meter	Average Lux	Luminous efficacy

Discussion Questions:-

1. What is the relationship between Lux and lumens?

Experiments for First Year Electrical Engg Lab 2015-16

2. What is the principle of operation of incandescent bulb? Explain its internal components and working with the help of diagram.
3. What is the principle of operation of fluorescent bulb? Explain its internal components and connection diagram.
4. What is the principle of operation of LED bulb?
5. What is the use of polar curve in illumination design?
6. What is luminous efficacy?
7. Write the luminous efficacy of different sources used in your practical in descending order.