

Explore Pharmacology

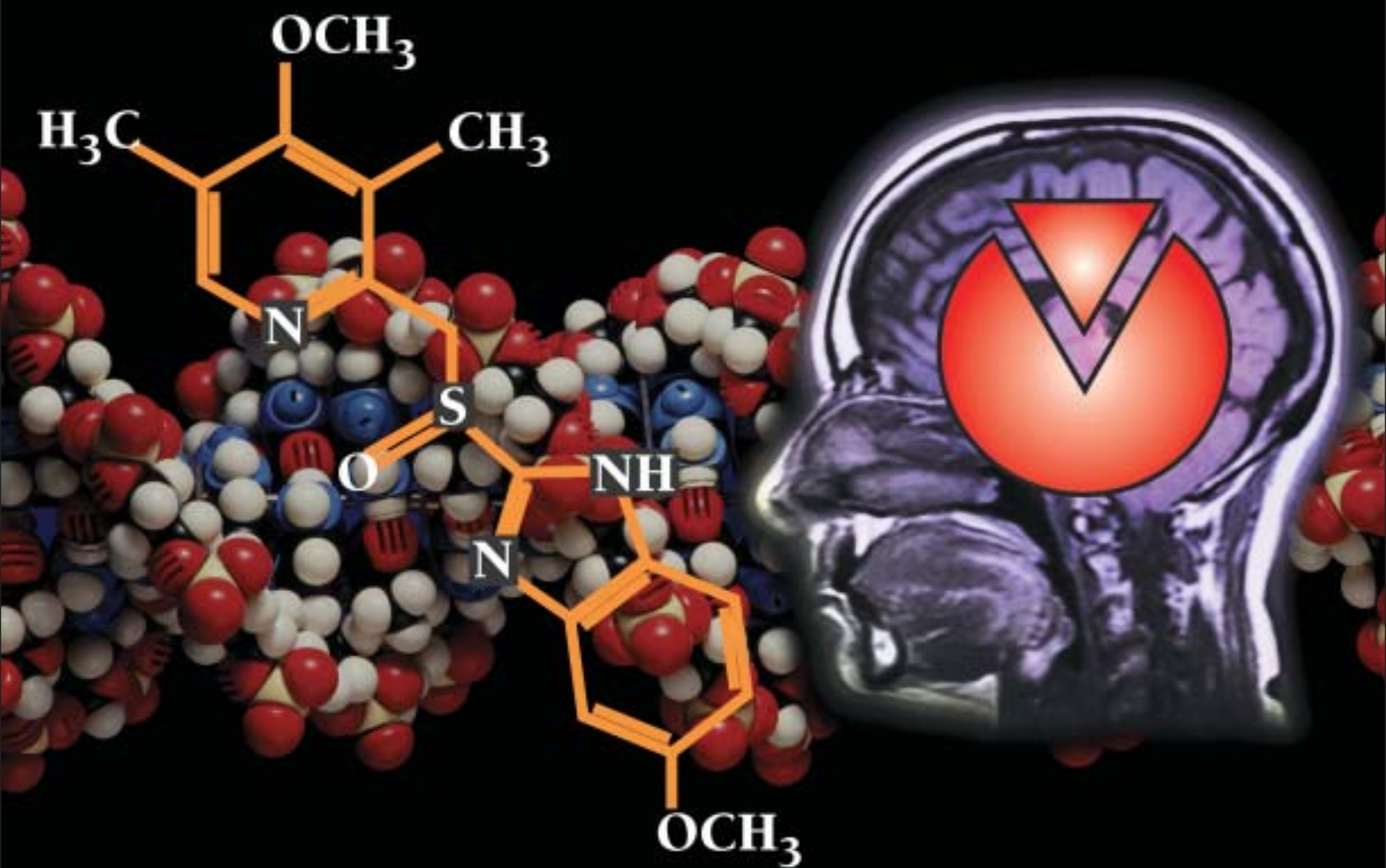

Graduate Studies in Pharmacology

This brochure is designed to provide college students with an overview of the fundamentals and applications of pharmacology.

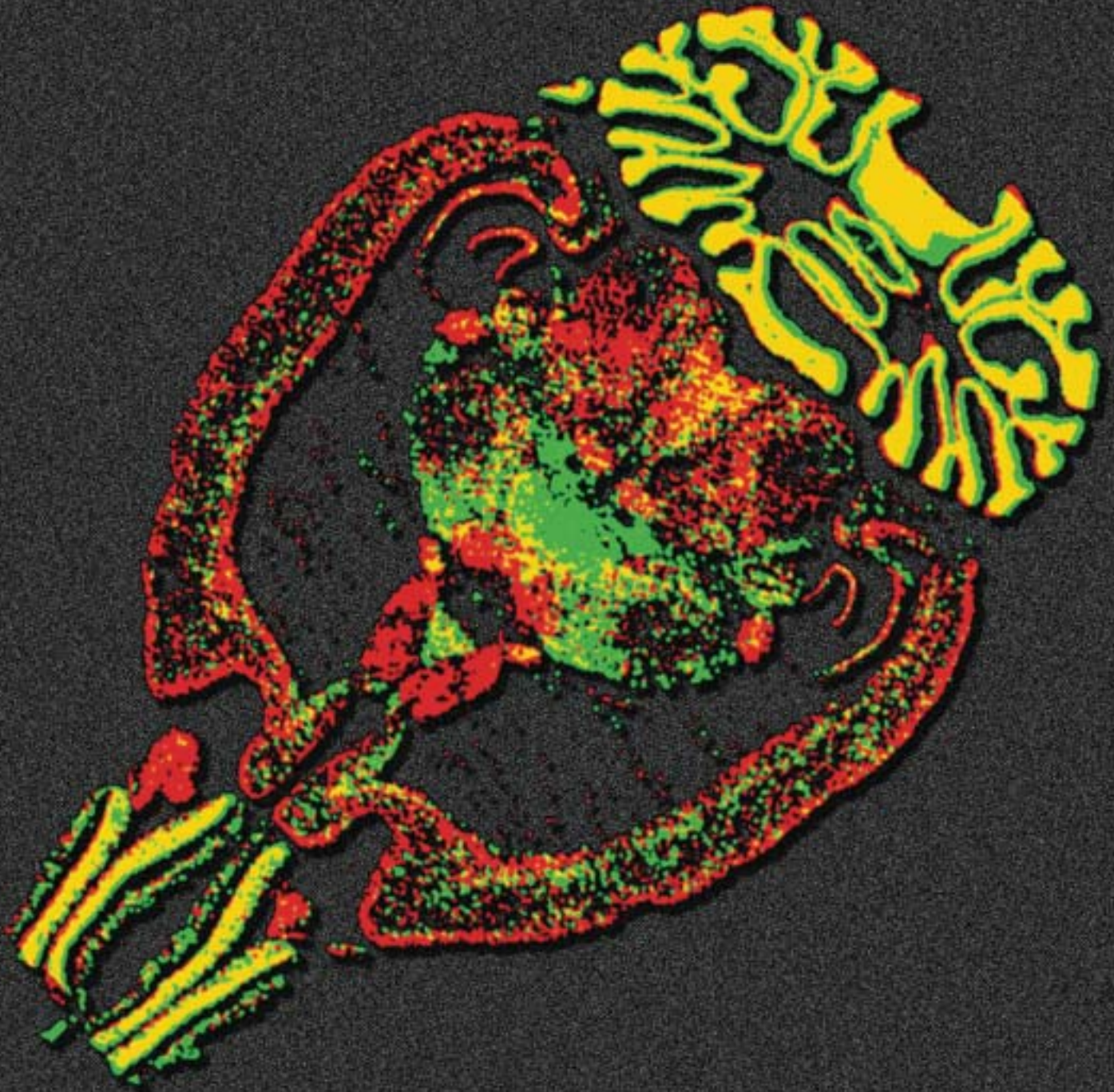

A colorized image of a sagittal section of rat brain with regions of separate TASK-1 (green) or TASK-3 (red) expression, and areas of overlapping TASK-1 and TASK-3 expression (yellow). The TASK proteins form channels in cell membranes and allow for the controlled movement of potassium ions. TASK channels are believed to contribute to many physiological processes and control the clinical actions of some inhalation anesthetics.



Opportunities and Challenges in Pharmacology

If you are a highly motivated and enquiring student who is seeking a career in the biomedical sciences and have a strong interest in making a major contribution to the understanding of both novel and current disease processes and the development of new therapies – then **Explore Pharmacology.**

In general terms, pharmacology is the science of drug action on biological systems.

In general terms, pharmacology is the science of drug action on biological systems. In its entirety, pharmacology embraces knowledge of the sources, chemical properties, biological effects and therapeutic uses of drugs. It is a science that is basic not only to medicine, but also to pharmacy, nursing, dentistry and veterinary medicine. Pharmacological studies range from those that examine the effects of chemical agents on subcellular mechanisms, to those that deal with the potential hazards of pesticides and herbicides, to those that focus on the treatment and prevention of major diseases with drug therapy. Pharmacologists also use molecular modeling and computerized design as drug discovery tools to understand cell function. New pharmacological areas include the genomic and proteomic approaches for therapeutic treatments.

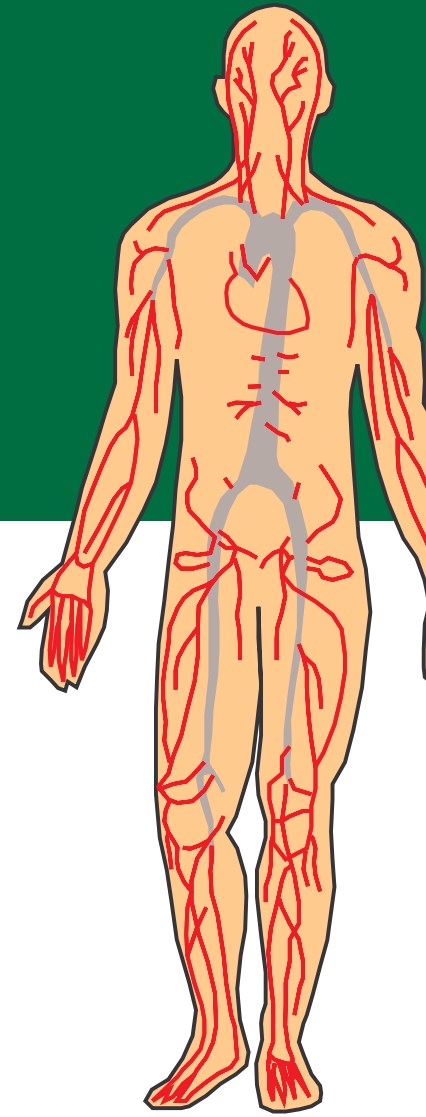

Integrating knowledge in many related scientific disciplines, pharmacology offers a unique perspective to solving drug, hormone, and chemical-related problems as they impinge on human health. As it unlocks the mysteries of drug actions, discovers new therapies, and develops new medicinal products, pharmacology inevitably touches all our lives.

While remarkable progress has been made in developing new drugs and in understanding how they act, the challenges that remain are endless. Ongoing discoveries regarding fundamental life processes will continue to raise new and intriguing questions that stimulate further research and evoke the need for a fresh scientific insight.

This booklet provides you with a broad overview of the discipline of pharmacology. It describes the many employment opportunities that await graduate pharmacologists, and outlines the academic path that they are advised to follow. If you enjoy problem solving, feel a sense of excitement and enthusiasm about understanding both drug action and the potential of drugs to offer new insights into disease mechanisms, then you have little choice but to ...

Explore Pharmacology

This will be the first step into an absorbing, challenging, productive, and rewarding scientific career.

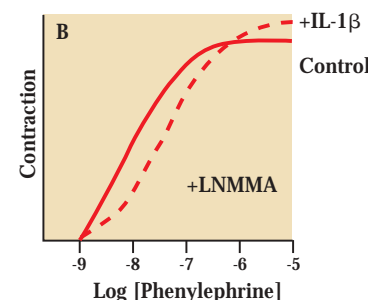
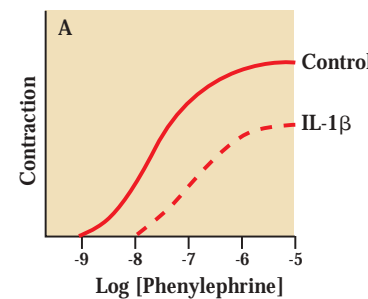

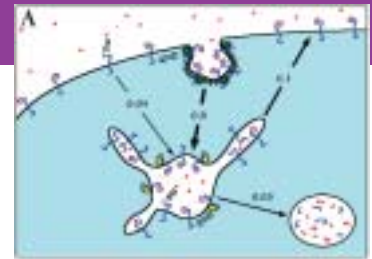
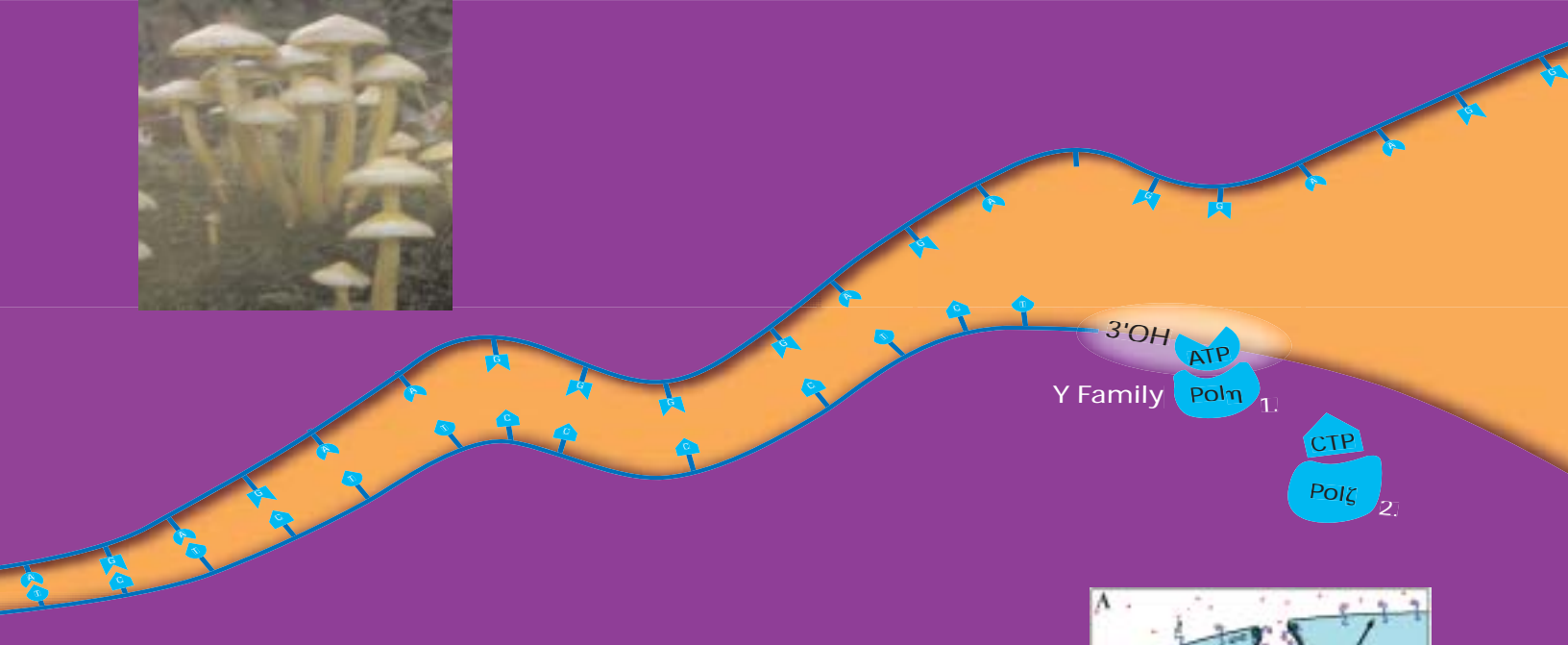

Pharmacology: Its Scope

Pharmacology is the study of the therapeutic value and/or potential toxicity of chemical agents on biological systems. It targets every aspect of the mechanisms for the chemical actions of both traditional and novel therapeutic agents. Two important and interrelated areas are: pharmacodynamics and pharmacokinetics. *Pharmacodynamics* is the study of the molecular, biochemical, and physiological effects of drugs on cellular systems and their mechanisms of action. *Pharmacokinetics* deals with the absorption, distribution, and excretion of drugs. More simply stated, *pharmacodynamics* is the study of how drugs act on the body while pharmacokinetics is the study of how the body acts on drugs. Pharmacodynamic and pharmacokinetic aspects of the action of chemical agents are applicable to all related areas of study, including toxicology and therapeutics.

Toxicology is the study of the adverse or toxic effects of drugs and other chemical agents. It is concerned both with drugs used in the treatment of disease and chemicals that may present household, environmental, or industrial hazards. *Therapeutics* focuses on the actions and effects of drugs and other chemical agents with physiological, biochemical, microbiological, immunological, or behavioral factors influencing disease. It also considers how disease may modify the pharmacokinetic properties of a drug by altering its absorption into the systemic circulation and/or its tissue disposition. Each of these areas is closely interwoven with the subject matter and experimental techniques of physiology,

biochemistry, cellular and molecular biology, microbiology, immunology, genetics, and pathology.

Pharmacology is the study of the therapeutic value and/or potential toxicity of chemical agents on biological systems.



The pharmacological sciences can be further subdivided:

Neuropharmacology is the study of drugs on components of the nervous system, including the brain, spinal cord, and the nerves that communicate with all parts of the body. Neuropharmacologists study drug actions from a number of differing viewpoints. They may probe new ways to use drugs in the treatment of specific disease states of the nervous system. Alternatively, they may study drugs already in use to determine more precisely the neurophysiological or neurobiochemical functions of the nervous system that are modified by drug action. Neuropharmacologists also use drugs as tools to elucidate basic mechanisms of neural function and to provide clues to the underlying neurobiological nature of disease processes.

Cardiovascular pharmacology concerns the effects of drugs on the heart, the vascular system, and those parts of the nervous and endocrine systems that participate in regulating cardiovascular function. Researchers observe the effects of drugs on arterial pressure, blood flow in specific vascular beds, release of physiological mediators, and on neural activity arising from central nervous system structures.

Molecular pharmacology deals with the biochemical and biophysical characteristics of interactions between drug molecules and those of the cell. It is molecular biology applied to pharmacological and toxicological questions. The methods of molecular pharmacology include precise mathematical, physical, chemical and molecular biological techniques to understand how cells respond to hormones or pharmacologic agents, and how chemical structure correlates with biological activity

Biochemical pharmacology uses the methods of biochemistry, cell biology, and cell physiology to determine how drugs interact with, and influence, the chemical “machinery” of the organism. The biochemical pharmacologist uses drugs as probes to discover new information about biosynthetic pathways and their kinetics, and

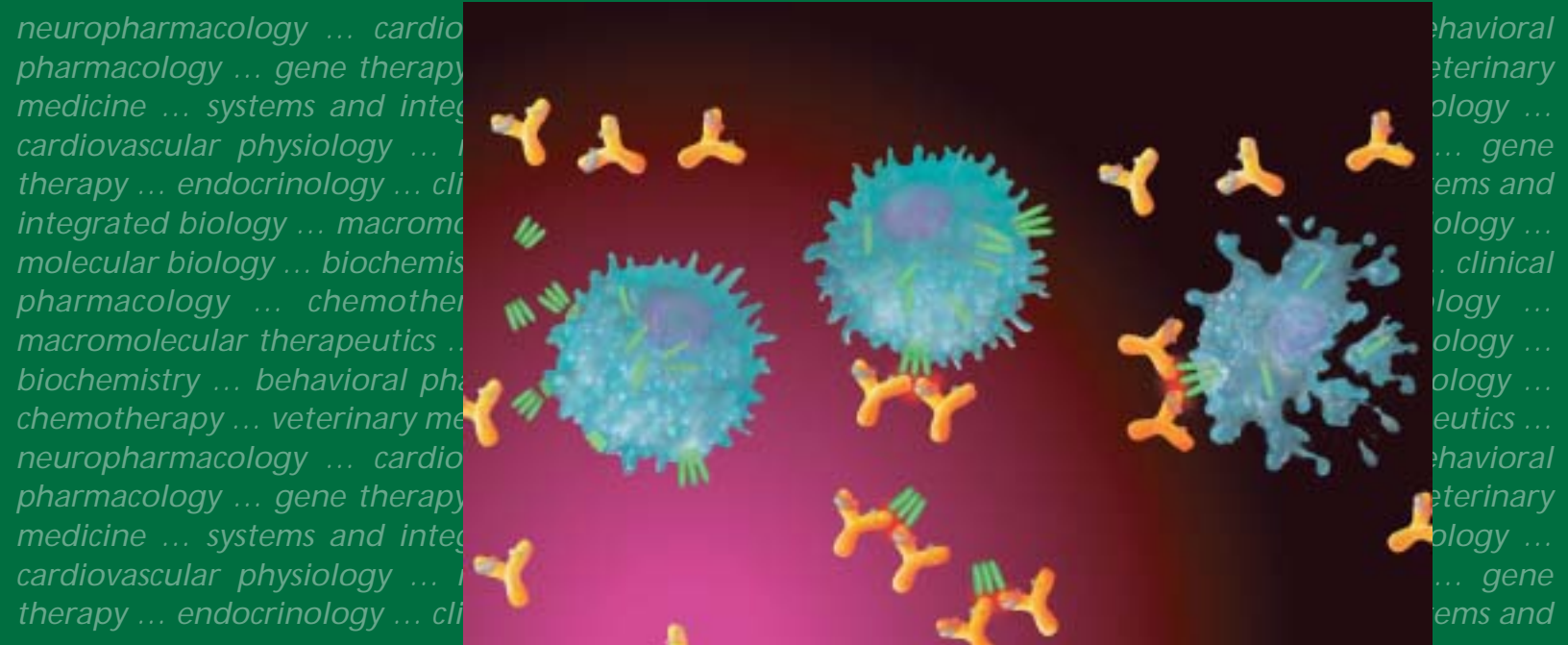

investigates how drugs can correct the biochemical abnormalities that are responsible for human illness.

Behavioral pharmacology studies the effects of drugs on behavior. Research includes topics such as the effects of psychoactive drugs on the phenomena of learning, memory, wakefulness, sleep, and drug addiction, and the behavioral consequences of experimental intervention in enzyme activity and brain neurotransmitter levels and metabolism.

Endocrine pharmacology is the study of actions of drugs that are either hormones or hormone derivatives, or drugs that may modify the actions of normally secreted hormones. Endocrine pharmacologists are involved in solving mysteries concerning the nature and control of disease of metabolic origin.

Clinical pharmacology is the application of pharmacodynamics and pharmacokinetics to patients with diseases and now has a significant pharmacogenetic component. Clinical pharmacologists study how drugs work, how they interact with the genome and with other drugs, how their effects can alter the disease process, and how disease can alter their effects. Clinical trial design, the prevention of medication errors, and the optimization of rational prescribing have become critical components of the work of clinical pharmacologists.

Chemotherapy is the area of pharmacology that deals with drugs used for the treatment of microbial infections and malignancies. Pharmacologists work to develop chemotherapeutic drugs that will selectively inhibit the growth of, or kill, the infectious agent or cancer cell without seriously impairing the normal functions of the host.

Systems and integrated pharmacology is the study of complex systems and whole animal model approaches to best predict the efficacy and usefulness of new treatment modalities in human experiments. Results obtained at the molecular, cellular, or organ system levels are studied for their relevance to human disease through translation into research in whole animal systems.

Veterinary pharmacology concerns the use of drugs for diseases and health problems unique to animals.

Often confused with pharmacology, **pharmacy** is a separate discipline in the health sciences. It is the profession responsible for the preparation, dispensing and appropriate use of medication, and provides services to achieve optimal therapeutic outcomes.

THE NEW CENTURY OF PHARMACOLOGICAL STUDIES

- Adverse Drug Reactions
- Anticancer & Antiviral Agents
- Behavioral Pharmacology
- Cancer Chemotherapy
- Cellular Pharmacology
- Combinatorial Chemistry
- Developmental Pharmacology
- Drug Policy & Regulation
- Environmental Pharmacology
- Gastrointestinal Pharmacology
- Gene Therapies
- Immunopharmacology
- New Drug Design and Development
- Pharmacogenetics
- Pharmacology of Aging
- Pulmonary Pharmacology
- Recombinant-DNA Derived Drugs
- Traditional and Herbal Medicines

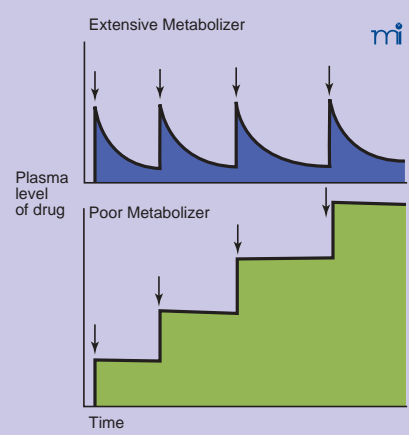
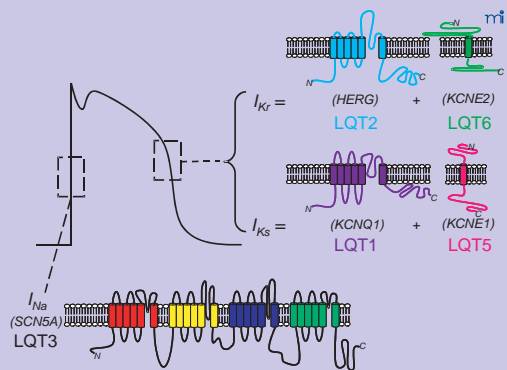
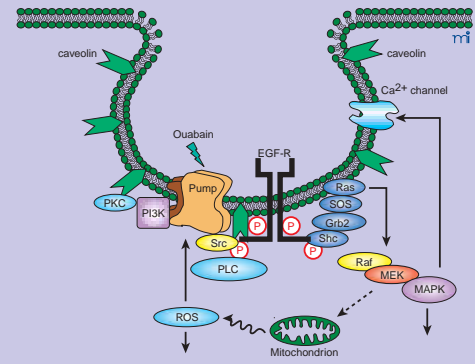

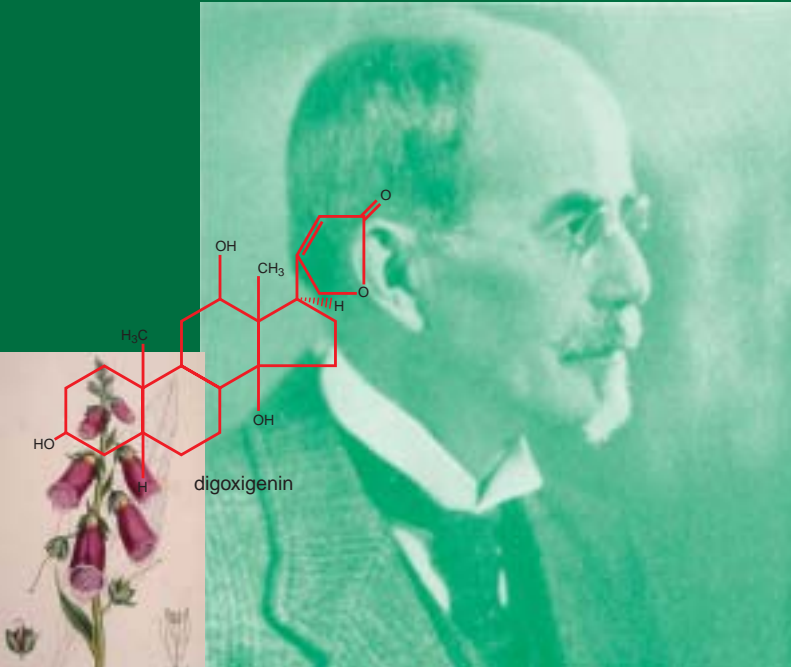

Pharmacology: Past and Present

Although drugs have been a subject of ancient interest since ancient times, pharmacology is a relatively new discipline in the life sciences. The term pharmacology comes from the Greek words *pharmakon*, meaning a drug or medicine and *logos*, meaning the truth about or a rational discussion.

Distinctions between the useful actions of drugs and their toxic effects were recognized thousands of years ago. As people tried plant, animal, and mineral materials for possible use as foods, they noted both the toxic and the therapeutic actions of some of these materials.

Past civilizations contributed to our present knowledge of drugs and drug preparations. Ancient Chinese writings and Egyptian medical papyri represent the earliest compilations of pharmacological knowledge. They included rough classifications of diseases to be treated, and recommended prescriptions for such diseases. While other civilizations made their own discoveries of the medicinal value of some plants, progress in drug discovery and therapeutics was minimal until after the dark ages.

The introduction of many drugs from the New World in the 17th century stimulated

*The term pharmacology comes from the Greek words *pharmakon*, meaning a drug or medicine, and *logos*, meaning the truth about or a rational discussion.*

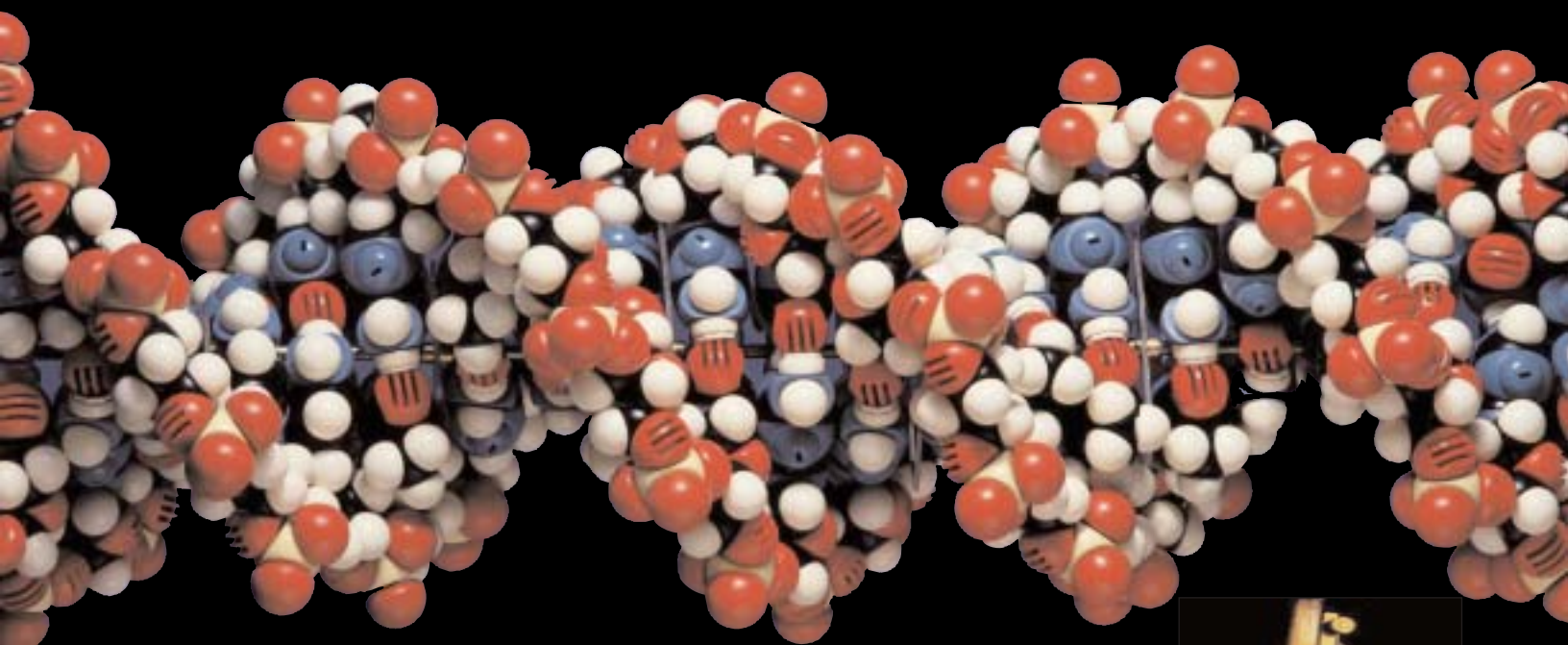

experimentation on crude preparations. These experiments were conducted chiefly to get some ideas about the possible toxic dosage for such drugs as tobacco, nux vomica, ipecac, cinchona bark, and coca leaves. By the 18th century, many such descriptive studies were being conducted. How drugs produced their effects was, however, still a mystery.



The birth of experimental pharmacology is generally associated with the work of the French physiologist, Francois Magendie, in the early 19th century. Magendie's research on strychnine-containing plants clearly established the site of action of these substances as being the spinal cord, and provided evidence for the view that drugs and poisons must be absorbed into the bloodstream and carried to the site of action before producing their effects. The work of Magendie and his pupil, Claude Bernard, on curare-induced muscle relaxation and carbon monoxide poisoning helped to establish some of the techniques and principles of the science of pharmacology.

It was in the German-speaking universities during the second half of the 19th century that pharmacology really began to emerge as a well-defined discipline. This process began with the appointment of Rudolf Buchheim to teach *material medica* at the University of Dorpat in Estonia. Long taught in medical schools, material medica was concerned largely with questions about the origins, constituents, preparation and traditional therapeutic uses of drugs. Buchheim, however, called for an independent experimental science of pharmacology, involving the study of the physiological action of drugs. He established the first institute of pharmacology at the University of Dorpat in 1847.

Among the students who received research training in Buchheim's laboratory was Oswald Schmiedeberg. In 1872, Schmiedeberg became professor pharmacology at Strasbourg, and over a number of years some 120 students from all over the world

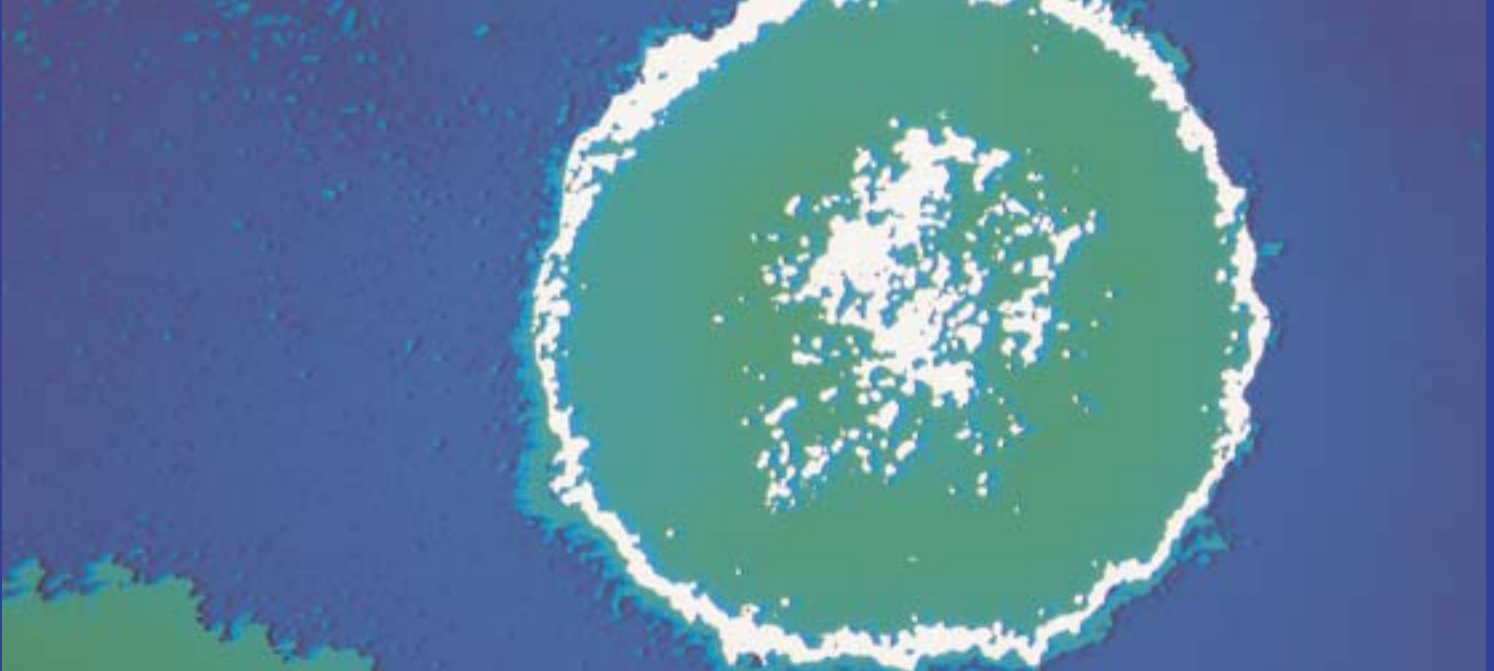

worked in his pharmacological institute. His students later occupied 40 academic chairs in pharmacology departments throughout the world.

One of the most eminent of his many distinguished pupils was John Jacob Abel, who brought the new science of experimental pharmacology from Germany to the USA.

In the beginning of the 20th century, Paul Ehrlich conceived the idea of specifically seeking special chemical agents with which to treat infections selectively, and is thus considered the “Father of Chemotherapy.” His work on the concept of the “magic bullet” treatment of infections paved the way for the triumphs of modern-day chemotherapy.

The progress and contribution of 20th century pharmacology have been immense, with over twenty pharmacologists having received Nobel prizes. Their contributions include discoveries of many important drugs, neurotransmitters and second messengers, as well as an understanding of a number of physiological and biochemical processes.

The field of pharmacology in general and the development of highly effective new drugs in particular have burgeoned during the last half of the 20th century. This unprecedented progress has paralleled

similar progress in related disciplines upon which pharmacology builds: molecular biology, biochemistry, physiology, pathology, anatomy, and the development of new analytical and experimental techniques and instruments.





Examples of Questions That Pharmacologists Ask

What tissue receptors (i.e. specific protein molecules) do drugs interact with to produce their effects, and how are these receptors linked to biological responses?

- What points in biochemical pathways are rate limiting and thus potential sites at which drugs act to alter pathways?
- How well do the traditional/accepted mechanisms of action for a given drug truly correlate with its biological effects, and are these mechanisms comprehensive enough to encompass all the effects of a drug?
- How do drugs act at cell surfaces to alter processes inside cells?
- How can drugs be used as selective probes to unravel details of biochemical and physiological processes?

Pharmacology encompasses all fields of biomedicine. The uniqueness of pharmacology is that it takes a proactive approach to biological systems



- What changes in the brain are responsible for schizophrenia and depression, and what agents will be most effective in treating these conditions?
- How do drugs with known mechanisms that are successful in treating certain conditions shed light on the conditions?
- How can knowledge of the structure of a macromolecule be used to design new chemical agents that will bind to and change the activity of the macromolecular (i.e. receptor)?
- How do organisms, organs, and individual cells develop increased or decreased sensitivity to drugs?
- How does the body terminate the actions of drugs?

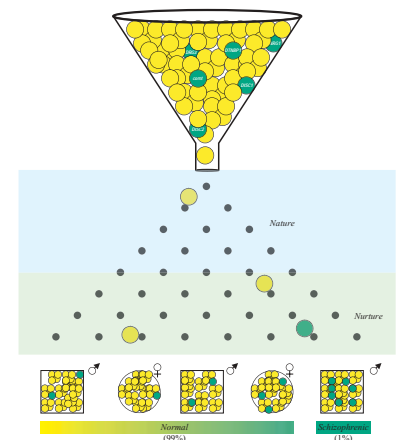
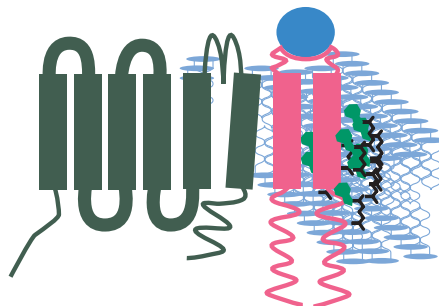



Why Choose Pharmacology?

Ask some students who have!

Comments from current students enrolled in graduate programs in pharmacology indicated that they pursue careers in pharmacology primarily because of its biomedical interdisciplinary character and the range of possibilities for conducting interesting research.

- "Pharmacology encompasses all fields of biomedicine. The uniqueness of pharmacology is that it takes a proactive approach to biological systems. As a result of its scientific diversity, pharmacology is appealing because it can prepare you for any field. Best of all, the field of pharmacology creates passionate, inspiring professors." –Dan M.
- "Pharmacology is helping to create some of the fastest paced medical advances today. It is exciting to be at the heart of this research." – anonymous
- "I chose to study pharmacology because it is the force behind many medical advances." –Rebecca S.
- "It gives me a lot of fulfillment to know that the science I am studying is helping to generate significant improvements in medical treatments." – anonymous

Many students perceived the flexibility and diversity of pharmacology programs as a key advantage:

- “It allows me to diversify, go into different areas of research, which gives me a job advantage over, say graduates in biochemistry, physiology or molecular biology.”
- “Pharmacology incorporates so many disciplines – biology, chemistry, genomics, physiology – it was a natural choice after finishing a liberal arts based undergraduate training.”
- “The flexibility to work in any area of research I want to pursue.”
- “So many fields to choose from.”
- “The diversity of research that goes on here. There is a big staff; there’s an expert in so many fields. If you have a question about anything, there is bound to be someone who can answer it.”

When asked if pharmacology differs from other life sciences, most students answered affirmatively. Those who considered pharmacology to be different generally pointed to its integration of other fields, its potential for practical application and its emphasis on human biomedical advances.

Pharmacology has a greater emphasis than other life sciences on eventually finding practical applications for research results.

- “Not only do we learn pharmacology, we must be proficient in many related fields – biochemistry, physiology, molecular and cellular biology – in other programs.”
- “Pharmacology has a greater emphasis than other life sciences on eventually finding a practical application for research results.”
- “I would be hard pressed to name a lab that doesn’t use drugs, so what makes our department different? I think it’s the recognition that drugs are tools for us – for both better research and a better understanding of what makes things go, plus the hope that some of our understanding can be applied to human disease.”



Career Opportunities

The breadth of pharmacological training opens a wide range of employment opportunities in academic, governmental, and industrial organizations. The shortage of pharmacologists and the increasing need for their expertise indicate that graduates will find employment that allows them to use their own special skills and pursue their areas of special interest.

Pharmacologists who wish to pursue joint teaching and research careers in academic institutions can join university faculties in all areas of the health sciences, including medicine, pharmacology, dentistry, osteopathy, veterinary medicine, and nursing. Universities also offer research opportunities in virtually every pharmacology specialty.

The shortage of pharmacologists and the increasing need for their expertise indicate that graduates will find employment that allows them to use their own special skills and pursue their areas of interest.

Government institutions employ pharmacologists in research centers such as the National Institutes of Health, the Environmental Protection Agency, the Food and Drug Administration, and the Centers for Disease Control. Government laboratories engage in basic research to study the actions and effects of pharmacological agents. The FDA assumes drug safety and regulatory responsibilities.

The applications of pharmacology to health and to agriculture have resulted in phenomenal growth of the drug manufacturing industry. Multinational pharmaceutical corporations utilize large staffs of pharmacologists to develop products and to

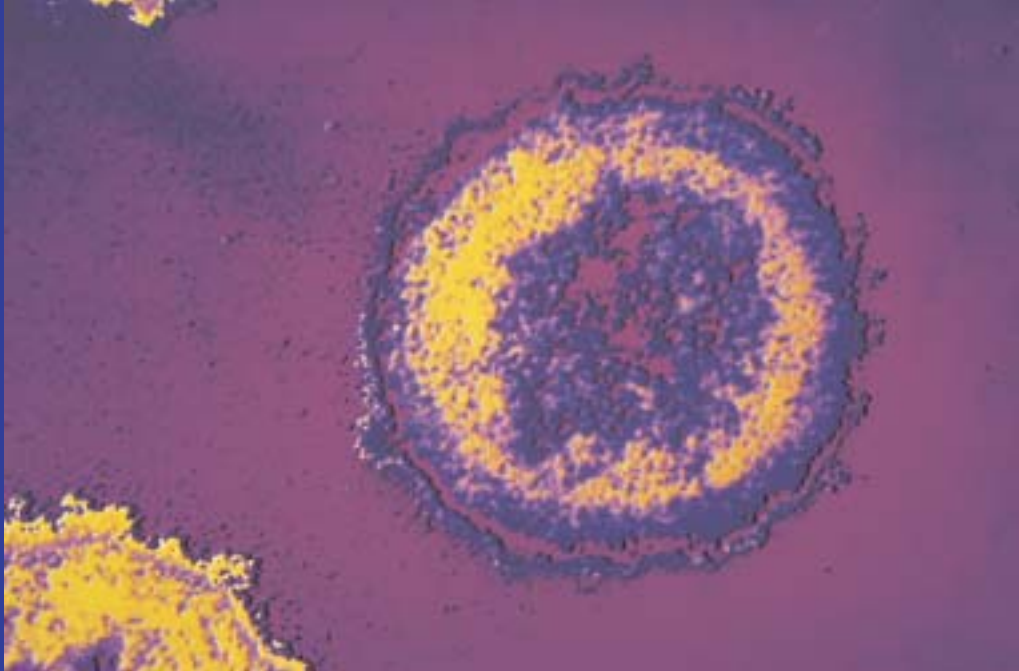

determine molecular or biochemical actions of various chemicals; toxicologists determine the safety of drugs with therapeutic potential.

Private research foundations involved in addressing vital questions in health and disease also draw from the research expertise of pharmacologists. Such foundations offer exciting opportunities for pharmacologists in a variety of specialty fields.

Some pharmacologists hold administrative positions in government or private industry. Working in this capacity, they may direct or oversee research programs or administer drug-related programs.

Regardless of the setting, pharmacologists often work as members of multidisciplinary research groups. Collaborating with scientists from many backgrounds contributes to the thrill of entering unexplored realms and participating in discoveries that have an impact on life and health.

*Regardless of the setting,
pharmacologists often work as
members of multidisciplinary
research groups.*

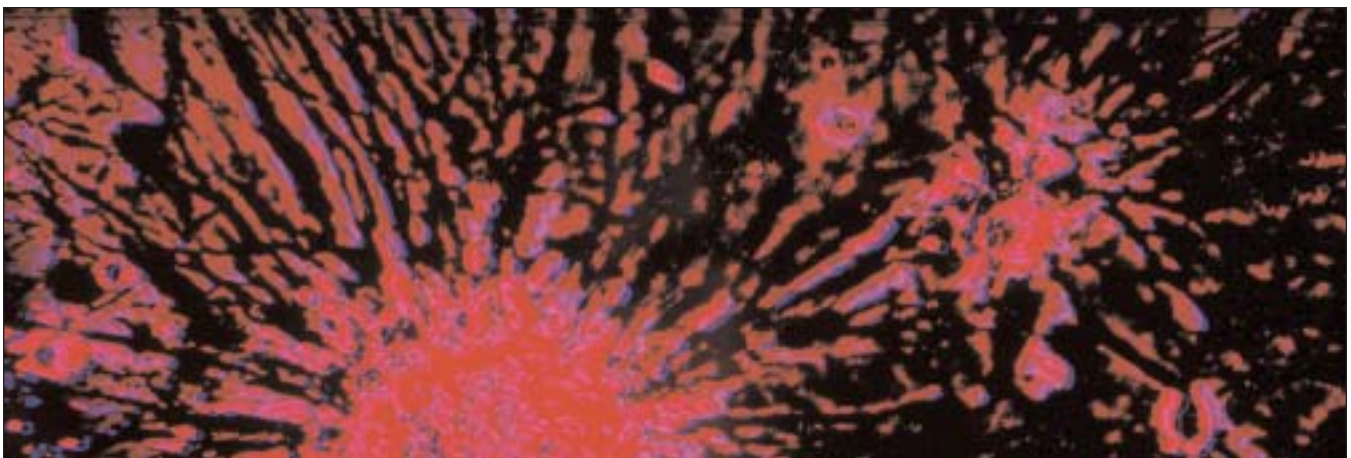

Preparing for a Career in Pharmacology



College Years

Since pharmacology is not offered in most undergraduate programs, students are advised to earn a bachelor of science degree in chemistry, one of the biological sciences, or in pharmacy

Because success in science depends on the ability to communicate clearly and think systematically and creatively, courses in writing, literature, and liberal arts are invaluable. Other undergraduate courses that help in preparing for pharmacology include physics, biology, molecular biology, biochemistry, organic and physical chemistry, mathematics (including differential and integral calculus), and statistics. If your college is among the increasing number of schools offering an undergraduate course in pharmacology, you should also take advantage of this special training opportunity.



Hands-on experience to see how scientists tackle problems is helpful. If you are interested in pursuing a career in biomedical science, get acquainted with professors who have active research programs and inquire about working as a laboratory assistant, either during the academic year or during the summer. Information about summer job opportunities in a laboratory can be obtained by contacting student placement services, work-study programs, or student research programs. Also, the American Society for

Pharmacology and Experimental Therapeutics has a summer fellowship program for undergraduate research opportunities in pharmacology departments. Information on this program can be obtained from the Society office.

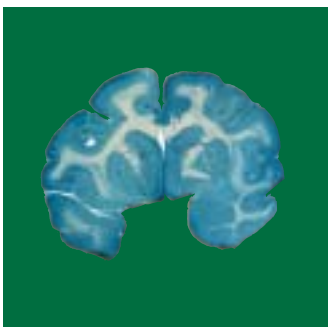

Graduate Study

To become a pharmacologist, a PhD degree or other doctoral degree is required. PhD programs in pharmacology are located in

medical schools, pharmacy schools, schools of veterinary medicine, schools of osteopathy and graduate schools of biomedical sciences. If you would like to obtain a medical degree as well, inquiries should be made about combined MD/PhD programs. Earning a PhD degree generally requires four to five years. Earning an MD/PhD degree takes about two years longer.



In addition to having course work prerequisites, each program requires that certain performance standards be met both with regard to grade-point average and scores on the Graduate Record Examination. Assistantships and fellowships including stipends and tuition fees are generally offered. Highly qualified students, including women and minorities, are actively recruited.

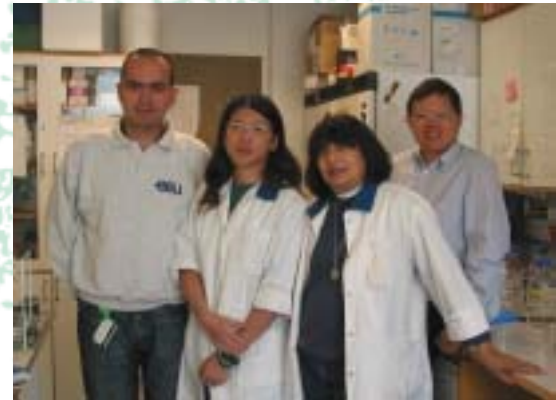

While programs vary substantially, the PhD curriculum typically includes both didactic courses and research-based studies. Courses in cellular and molecular biology, biochemistry, physiology, neurosciences, statistics, and research design are designed to broaden and deepen scientific backgrounds. In addition, a solid foundation in the pharmacological sciences is provided. This may include basic pharmacology, molecular pharmacology, chemotherapy and toxicology, as well as specific discipline and organ-system based courses such as cardiovascular pharmacology, renal pharmacology, and neuropharmacology. The major portion of the graduate degree program is, however, devoted to laboratory research. The primary goal is to complete an original and creative research study that yields new information and withstands peer review.

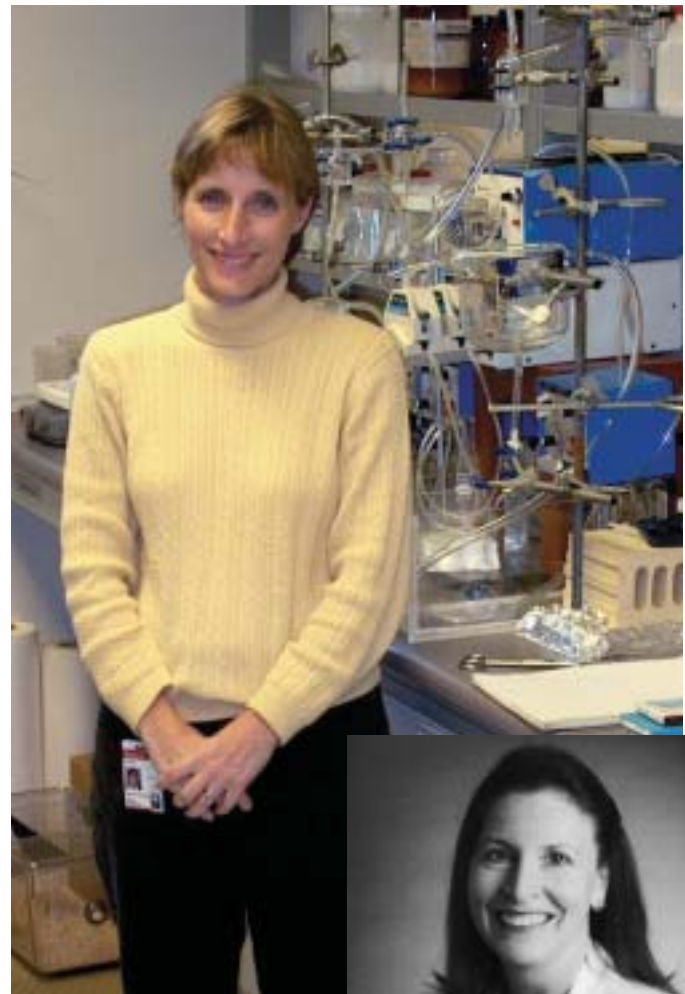

Because emphases in programs differ greatly, it is important to investigate several programs, keeping in mind how they relate to your own areas of interest. Thorough inquiries should be made into:



- Areas of research expertise among faculty
- Publications of faculty
- Research funding of faculty
- Student flexibility in choosing research projects
- Availability of training grants and stipends designated for graduate student support
- Extent to which research efforts are independent or linked by interdisciplinary team approaches
- Positions held by previous graduates.



Postdoctoral Research

Before taking permanent positions, most PhD graduates complete two to four years of further research training. This provides the opportunity to work on a second high-level research project with an established scientist, to expand research skills and experience, and to mature as a scientist. The combination of graduate and postdoctoral experiences enables the young investigator to contribute new perspectives on a unique area of research. Salaries and fellowships for postdoctoral scientists reflect research experiences and expectations of the studies to be conducted.

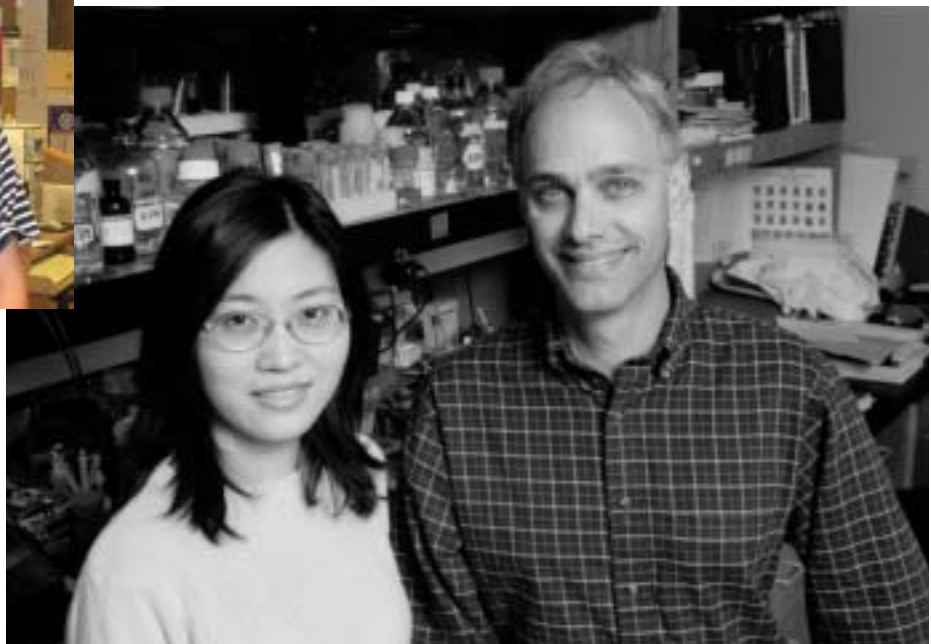
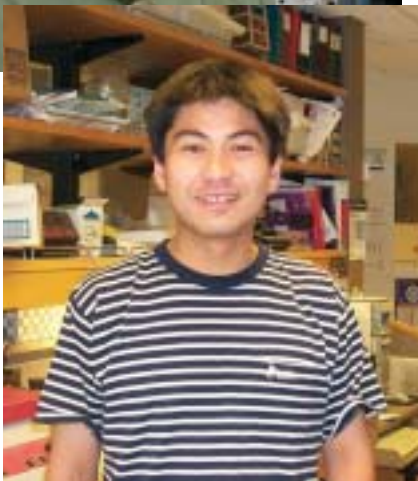

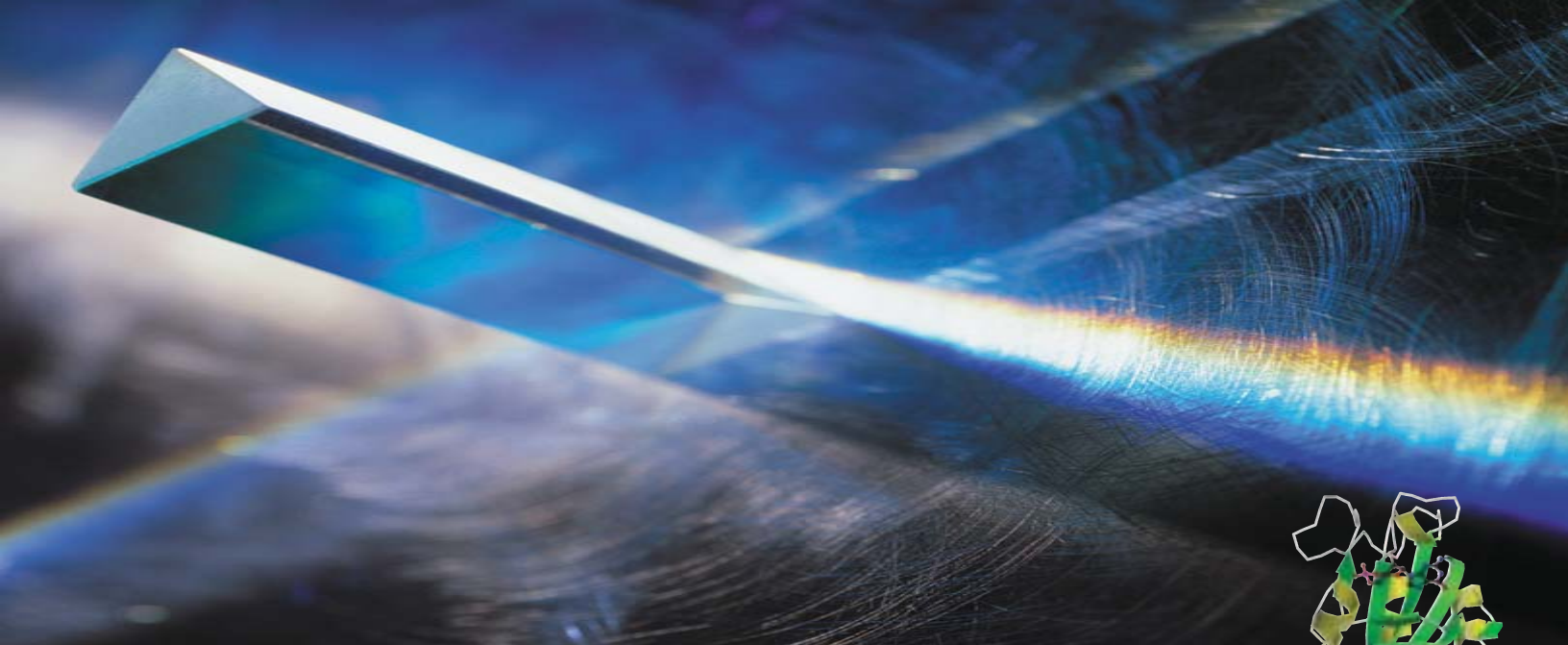

Achievements and New Frontiers



Research in pharmacology extends across a wide frontier that includes developing new drugs, learning more about the properties of drugs already in use, investigating the effects of environmental pollutants, using drugs as probes to discover new facts about the functions of cells and organ systems, and exploring how genetic variation impacts drug disposition and efficacy.

A major contribution of pharmacology has been the advancement of knowledge about cellular receptors with which hormones and chemical agents interact. Through this research an understanding of the process of activation of cell surface receptors and the coupling of this response to intracellular events has been made possible. New drug development has focused on steps in this process that are sensitive to modulation. Identifying the structure of receptors will allow scientists to develop highly selective drugs with fewer undesirable side effects.

Out of this research have come a multitude of discoveries and achievements: advances in antibacterial and anticancer chemotherapy which have played a major role in reducing infectious diseases produced by bacteria and certain spirochetes and in producing cures for certain types of cancers; the development of drugs for the treatment of hypertension, congestive heart failure, and cardiac arrhythmias; more effective treatments for asthma; and the development of drugs that control pain, anxiety and chronic psychiatric disorders with far fewer unpleasant side effects than before. A second major contribution that is currently receiving renewed attention is the area of



The systemic delivery of naked DNA to within diseased organs offers both advantages and challenges for gene therapy. The diaphragm tissue shown above comes from mutant (mdx) mice that are deficient in dystrophin. Subsequent to receiving therapeutic DNA via intravascular injection, however, the mice express dystrophin (immunostained red) beneath cell membranes.

pharmacogenetics, i.e., how variation in genetic information impacts how a particular drug is adsorbed, metabolized, and/or eliminated, as well as how the particular drug interacts with its cellular targets. This field, which has experienced a major boost from the completion of the human genome project, offers considerable promise for the development of novel therapeutics, optimized drug trials, and medicine tailored to your personal response.

Over the next several decades, the knowledge emerging from pharmacological studies will have an immeasurable impact on society. Major challenges include the development of drugs for the treatment of AIDS and other viral diseases, cancer, drug-resistant bacteria, and the rejection of organ transplants. A better understanding of the potential toxic effects of abused substances on the fetus and on the heart, brain, and other organ systems will evolve. Research on drug addiction holds the promise of developing new treatments for drug dependence and withdrawal as well as identifying individual differences that may influence a person's susceptibility to drug abuse. Gene therapy is a new focus of pharmacological research. The possibility of developing gene products that would alter the course of a disease will open new horizons in the effectiveness and the selectivity of therapeutic agents. The effect of the chemical substances in the environment and their possible causal relationship to cancer or birth defects will be an area of great social concern and one with which pharmacologists will be confronted. Finally, the discoveries in the area of pharmacogenetics will allow for a better understanding and avoidance of adverse drug reactions, as well as the development of individualized therapeutic regimens.

Progress in areas of social concern and in aspects of health-related drug intervention will require pharmacologists who are not only schooled in scientific disciplines, but who possess a sense of ethics, a sense of logic, and a firm understanding of the philosophical overtones of their research.

It is, indeed, an exciting and challenging time to become a pharmacologist!

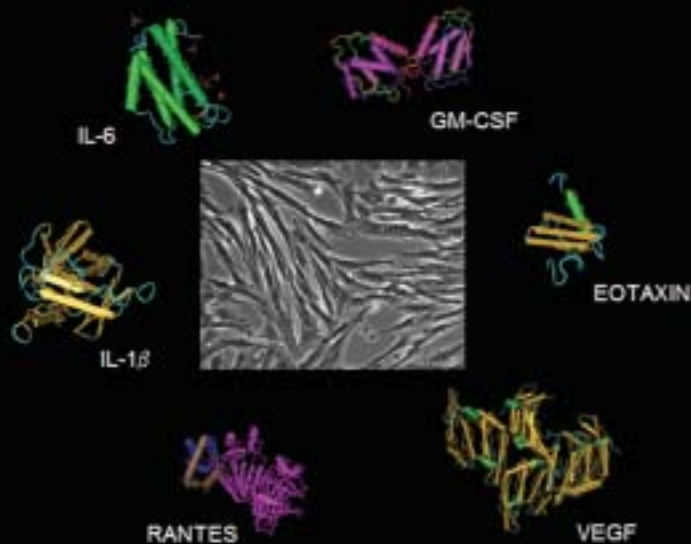

This brochure was prepared by the Graduate Recruitment and Education Committee of the American Society for Pharmacology and Experimental Therapeutics, September 2003. Many of the images presented here are courtesy of the ASPET publication *Molecular Interventions*. All rights reserved.

Barbara S. Beckman, Chair

Carol Bender	Stephanie W. Watts
Edward Bilsky	Paula Witt-Enderby
Jean M. Devlin	Gary C. Rosenfeld
Raymond R. Mattingly	Lawrence P. Carter
Jose F. Rodriguez	Carrie Northcott
Myron L. Toews	Cinda J. Helke

Editor: Christine K. Carrico

Art Director: Phillip Payette

Thanks to the following who have contributed pictures, diagrams, and content:

Araba Adjei	Otabek Imamov
Douglas A. Bayliss	Paul A. Insel
George Breese	Stephanie S. Jeffrey
Jerry J. Buccafusco	David D. Ku
Guojun Cheng	David Mangelsdorf
Shunsuke Chikuma	Sharen E. Mckay
Raymond J. Dingledine	Yoko Omoto
Sue P. Duckles	William M. Pardridge
Anthony Fauci	Ronald J. Shebuski
David A. Flockhart	Bianca Thomae
William Gerthoffer	Margaret Warner
F. Peter Guengerich	Richard M. Weinshilboum
Jason M. Haugh	Raymond L. Woosley
Bethany Holycross	Yuan Zhou
Leaf Huang	

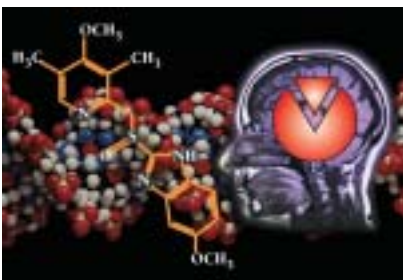

American Society for Pharmacology and Experimental Therapeutics
 9650 Rockville Pike, Bethesda, Maryland 20814
www.aspet.org