

F-5500 Insertion and Inline Thermal Mass Flow Sensor Installation and Operation Guide



Notice

This publication must be read in its entirety before performing any operation. Failure to understand and follow these instructions could result in serious personal injury and/or damage to the equipment. Should this equipment require repair or adjustment beyond the procedures given herein, contact the factory at:

ONICON
11451 BELCHER ROAD SOUTH
LARGO, FL 33773
TELEPHONE: 727-447-6140
FAX: 727-442-5699
EMAIL: SERVICE@ONICON.COM

Download Technical Data Sheets from our website:
www.onicon.com

ONICON believes that the information provided herein is accurate; however, be advised that the information contained herein is NOT a guarantee for satisfactory results. Specifically, this information is neither a warranty nor guarantee, expressed or implied, regarding performance, merchantability, fitness, or any other matter with respect to the products; nor recommendation for the use of the product/process information in conflict with any patent. Please note that ONICON reserves the right to change and/or improve the product design and specification without notice.



ONICON F-5500 Manuals:
• **ONICON F-5000 View™ Manual**

All ONICON Manuals and software available in English only.

Table Of Contents

1. Introduction	Page 5
a. Menu Trees	Page 5
b. Quick Start Guide	Page 15
2. Installation (Mechanical)	Page 17
a. Installation Depth	Page 22
b. Orientation of Flowmeter	Page 24
c. Rotating the Probe/Enclosure	Page 21
d. Sensor Elements	Page 21
e. Changing the Orientation of the Display	Page 28
f. Compression Fittings	Page 24
3. Wiring (Electrical)	Page 29
a. General Wiring	Page 30
b. Input Power	Page 30
c. Signal Wiring	Page 31
d. Pulse/Alarm Wiring (optional feature)	Page 33
e. RS485 Wiring: Modbus RTU or BACnet MS/TP (optional feature)	Page 35
f. HART wiring	Page 36
4. Operation (Standard Operation)	Page 39
a. Start Up	Page 39
b. Programming	Page 41
c. Zero CAL-CHECK®	Page 58
5. Communication Protocols	Page 62
a. RS485 Modbus RTU	Page 62
b. BACnet MS/TP	Page 69
c. HART	Page 73
6. Maintenance	Page 78
a. Precautions	Page 78
b. General	Page 79
c. Troubleshooting	Page 80
7. Appendices	Page 86
a. Specifications	Page 86
b. Agency Approvals	Page 88
c. Dimensions	Page 89
d. Warranty	Page 89
e. Returning your meter	Page 93
8. Glossary of Terms and Abbreviations	Page 94
9. Index	Page 95

Introduction: Safety Information

This sensor was calibrated at the factory before shipment. To ensure correct use of the sensor, please read this manual thoroughly.

Regarding this Manual:

- This manual should be passed on to the end user.
- Before use, read this manual thoroughly to comprehend its contents.
- The contents of this manual may be changed without prior notice.
- All rights reserved. No part of this manual may be reproduced in any form without ONICON's written permission.
- All reasonable effort has been made to ensure the accuracy of the contents of this manual. However, if any errors are found, please inform ONICON.
- ONICON assumes no responsibilities for this product except as stated in the warranty.
- If the customer or any third party is harmed by the use of this product, ONICON assumes no responsibility for any such harm owing to any defects in the product which were not predictable, or for any indirect damages.

Safety Precautions:

The following general safety precautions must be observed during all phases of installation, operation, service, and repair of this product. Failure to comply with these precautions or with specific warnings given elsewhere in this manual violates safety standards of design, manufacture, and intended use of the product. ONICON Incorporated assumes no liability for the customer's failure to comply with these requirements. If this product is used in a manner not specified in this manual, the protection provided by this product may be impaired.

The following symbols are used in this manual:



Messages identified as "Note" or "Important Note" contain information critical to the proper operation of the product.



Messages identified as "Caution" (refer to accompanying documents) contain information regarding potential damage to the product or other ancillary products. Messages identified as "Warning" contain information regarding the personal safety of individuals involved in the installation, operation or service of this product.

Introduction: Menu Trees

Main Menu

Fig. 1.1: F-5500 Menu Tree - Main Menu

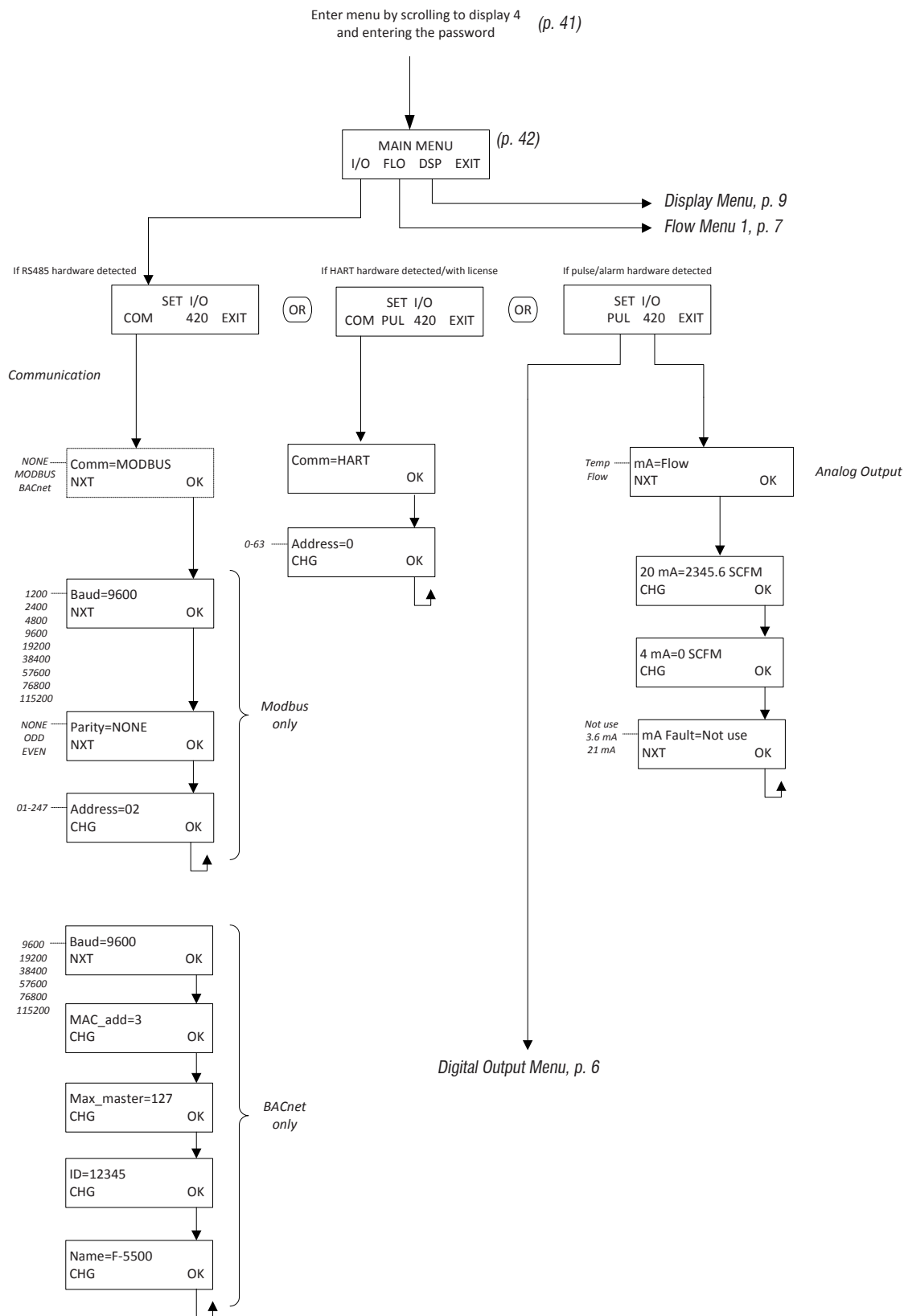

Introduction: Menu Trees

Digital Output

Fig. 1.2: F-5500 Menu Tree - Digital Output

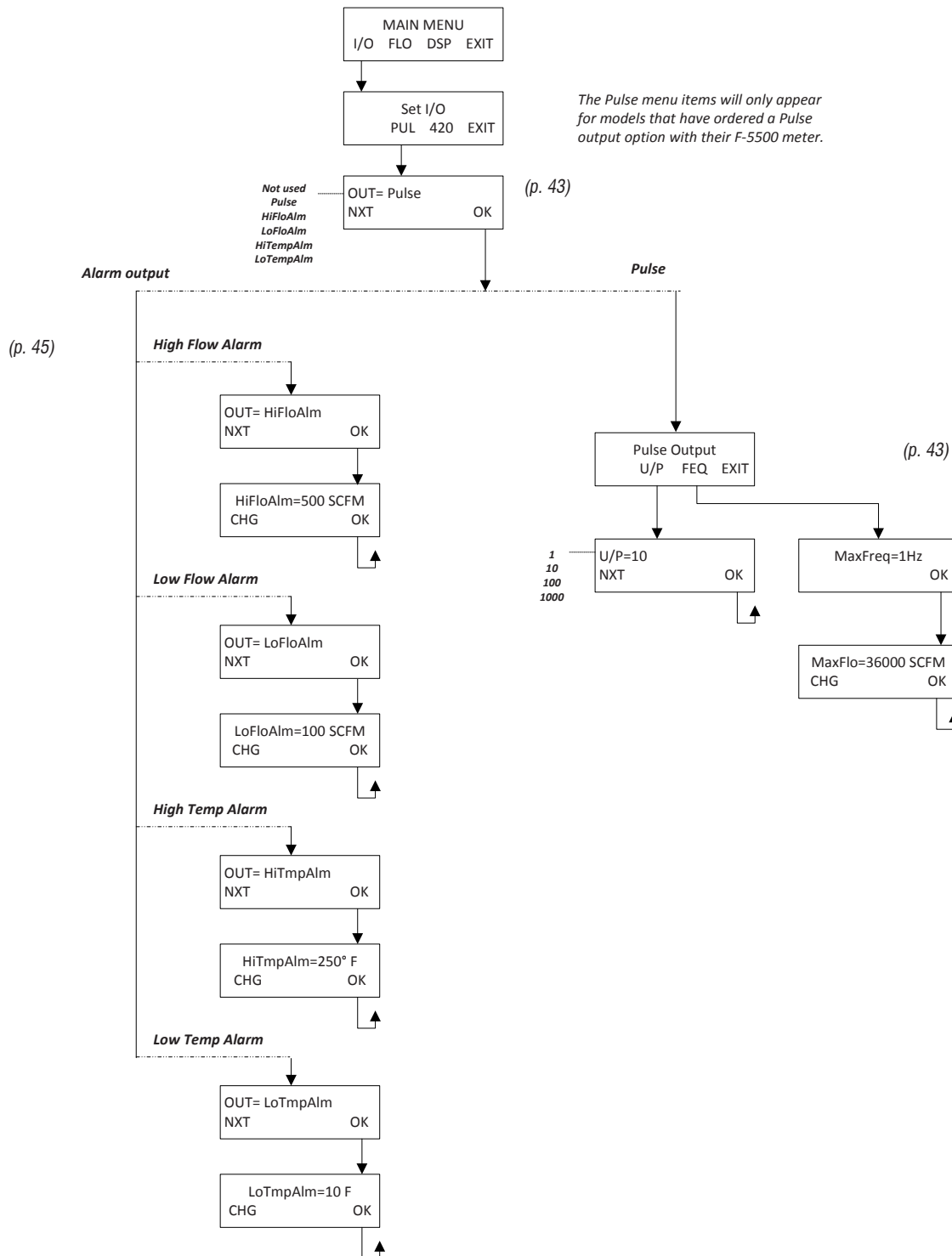

The Pulse menu items will only appear for models that have ordered a Pulse output option with their F-5500 meter.

(See Flow Menu 2, p. 8, for more alarm settings)

Introduction: Menu Trees

Flow Menu 1

Fig. 1.3: F-5500 Menu Tree - Flow Menu 1

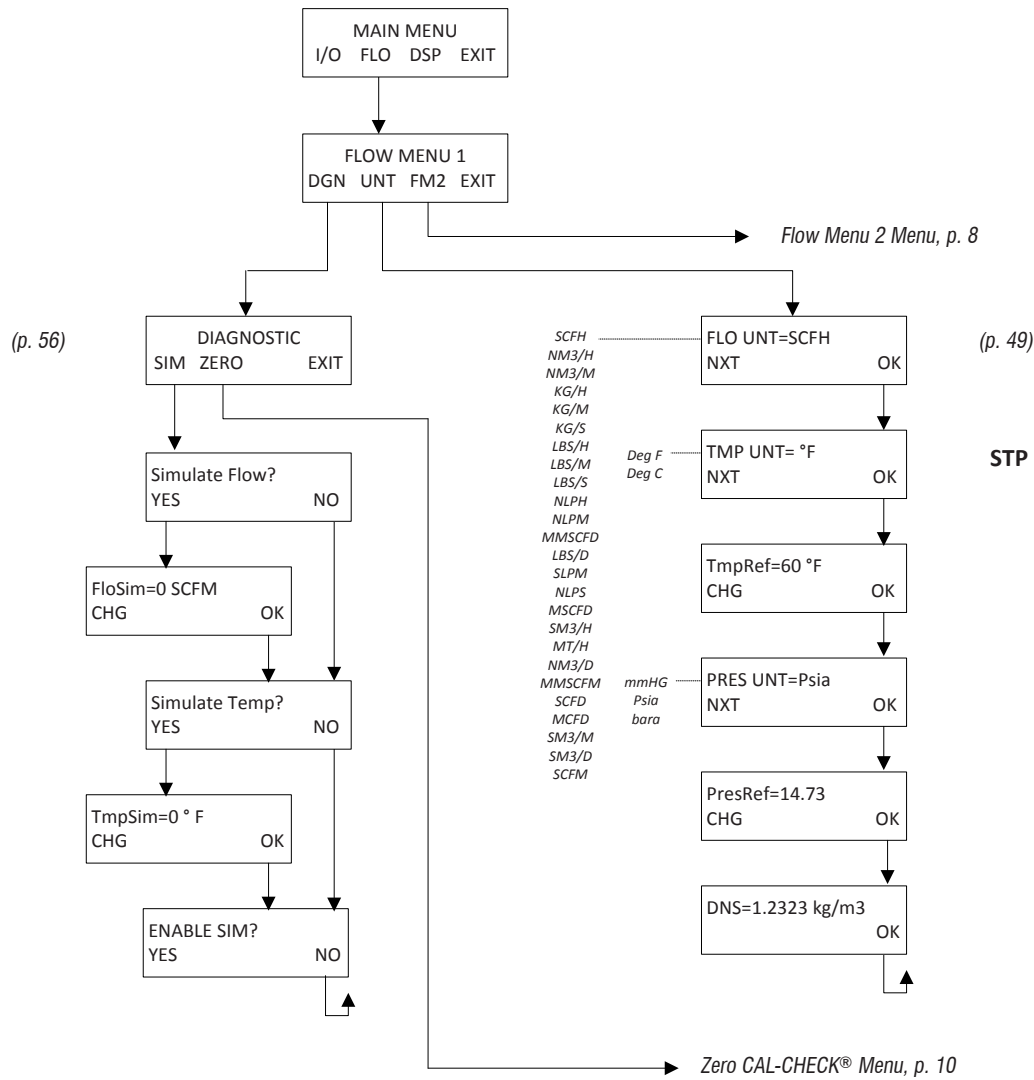

Introduction: Menu Trees

Flow Menu 2

Fig. 1.4: F-5500 Menu Tree - Flow Menu 2

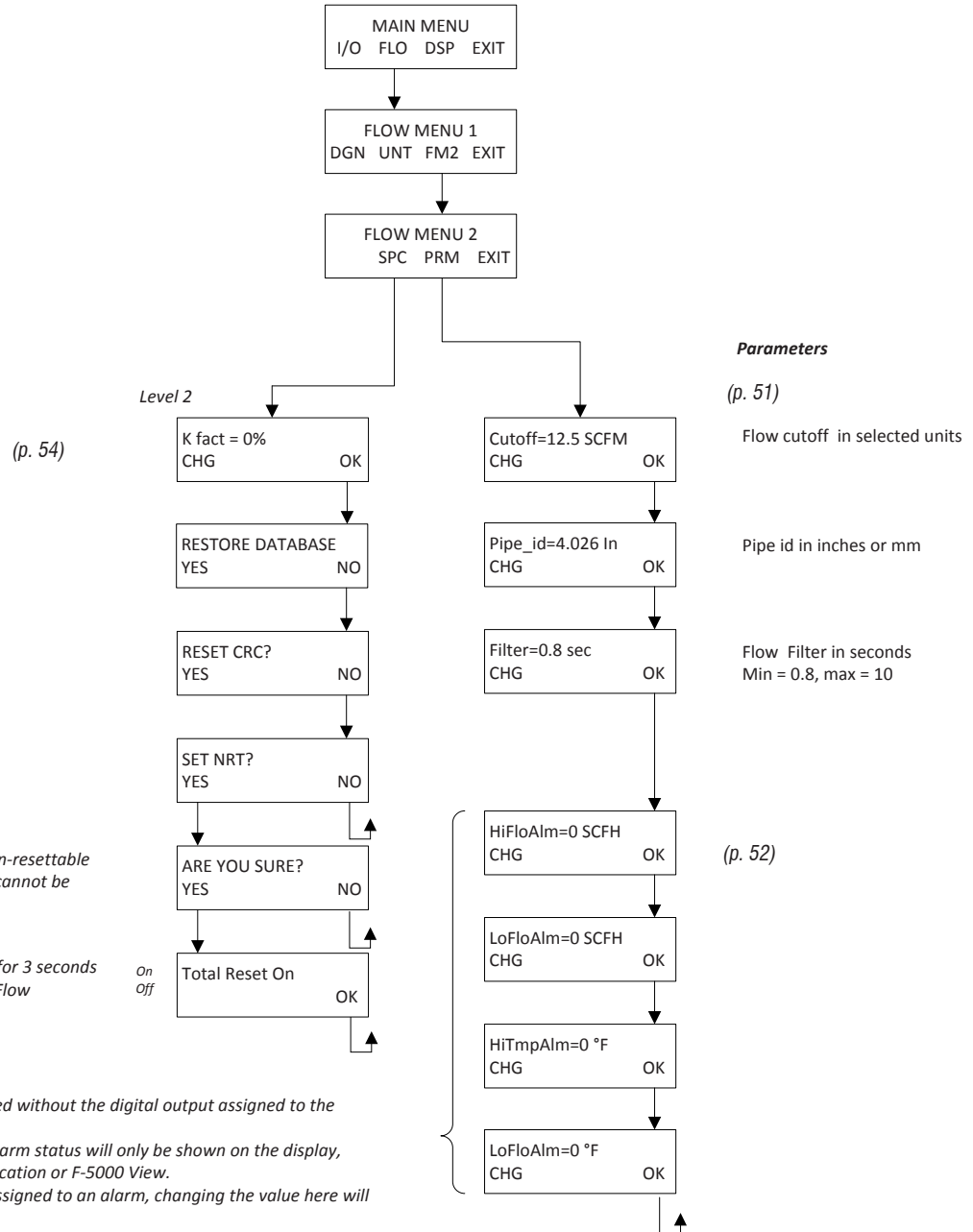

WARNING: Once the non-resettable totalizer is activated, it cannot be undone.

This message will show for 3 seconds before returning to the Flow Parameter 2 Menu.

These alarms can be used without the digital output assigned to the alarm. If that is the case, the alarm status will only be shown on the display, through serial communication or F-5000 View. If the digital output is assigned to an alarm, changing the value here will change that setting.

Introduction: Menu Trees

Display Menu

Fig. 1.5: F-5500 Menu Tree - Display Menu

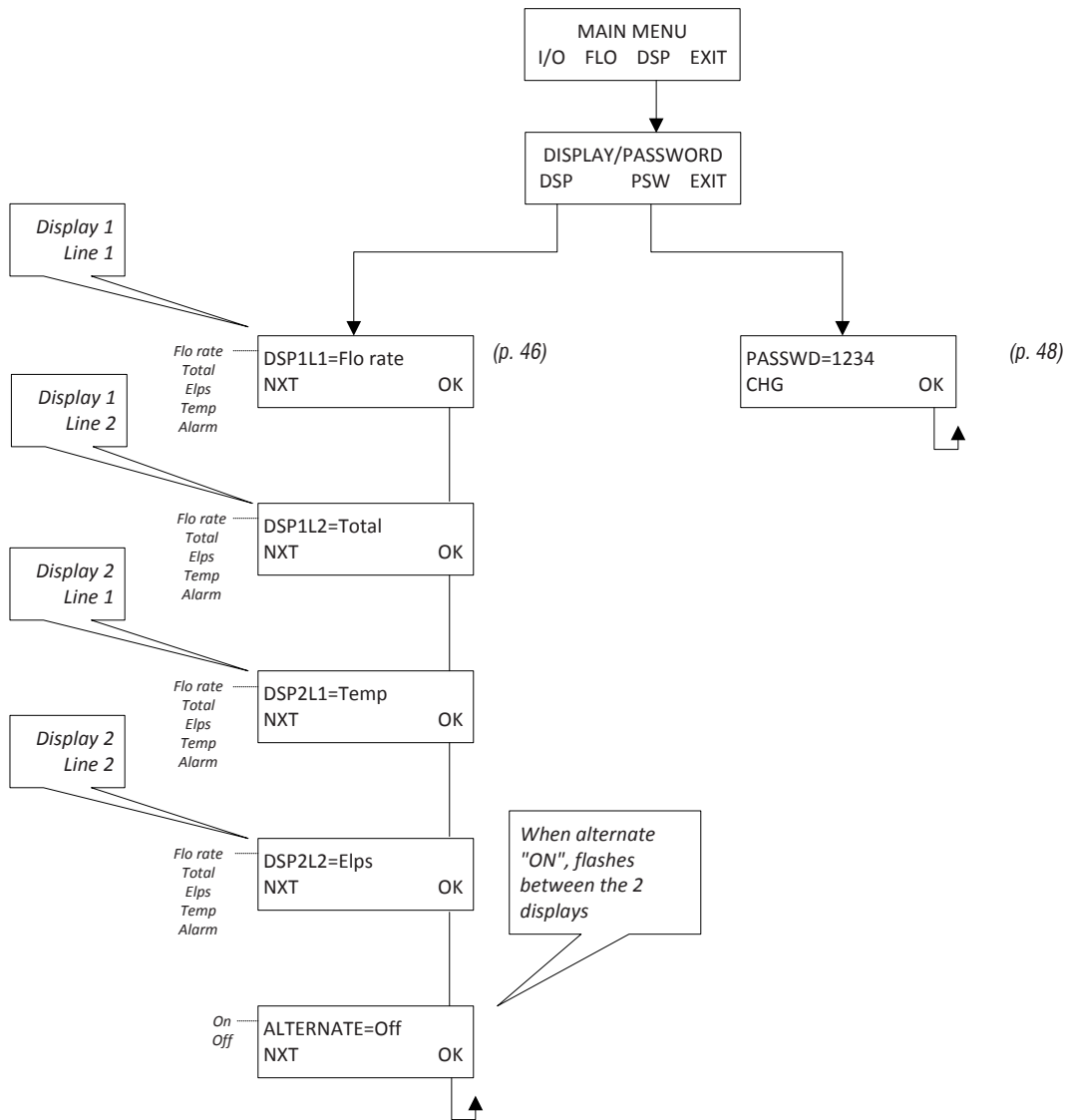

NOTE: All readings updated every second

- Flo Rate = Flow rate of process gas
- Total = Total flow of process gas
- Elps = Elapsed time since reset of flow total
- Temp = Temperature of process gas
- Alarm = Notification of errors; diagnostic errors

Introduction: Menu Trees

Zero CAL-CHECK®
Menu

Fig. 1.6: F-5500 Menu Tree - Zero CAL-CHECK® Menu

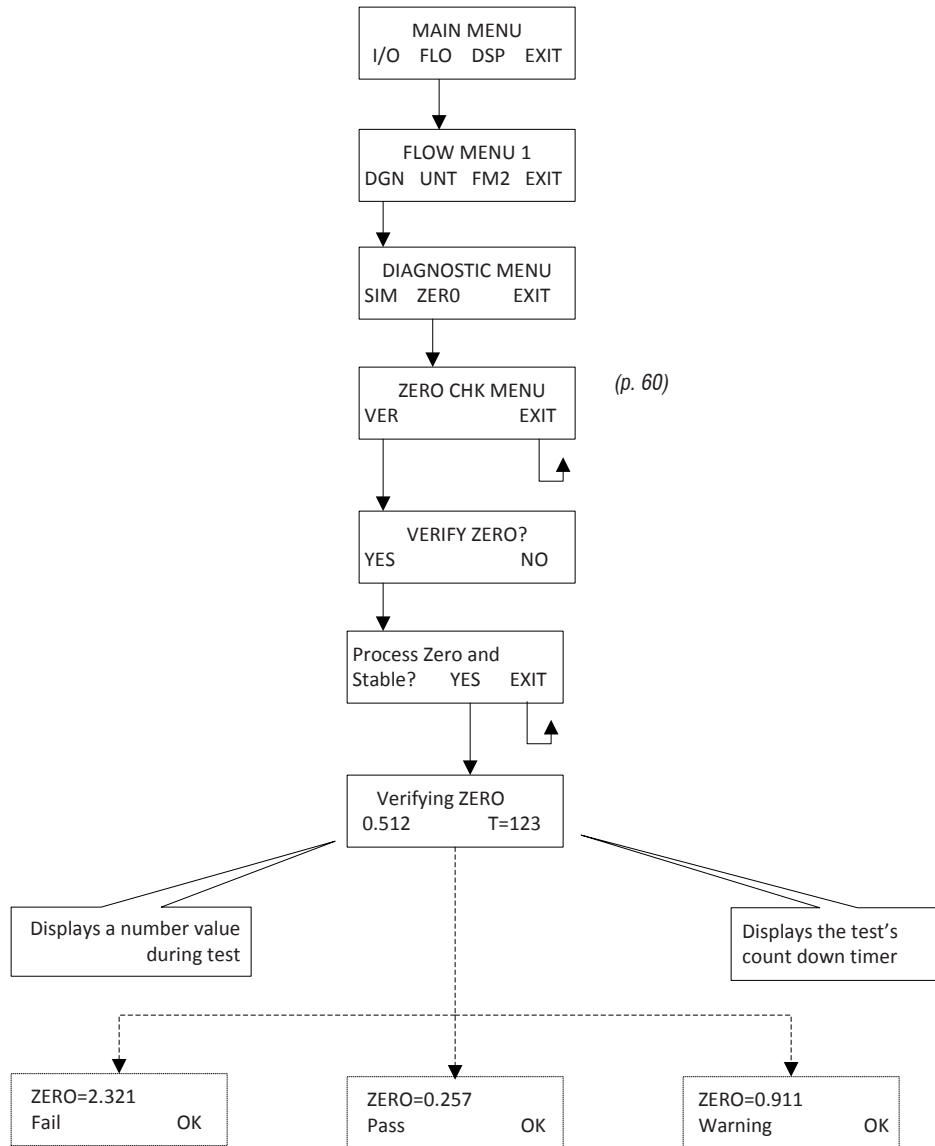

Introduction: Menu Trees

Engineering Display

Fig. 1.7: F-5500 Menu Tree - Engineering Display

Enter: Press F1 & F2 at the same time
Press F4 to return to normal mode

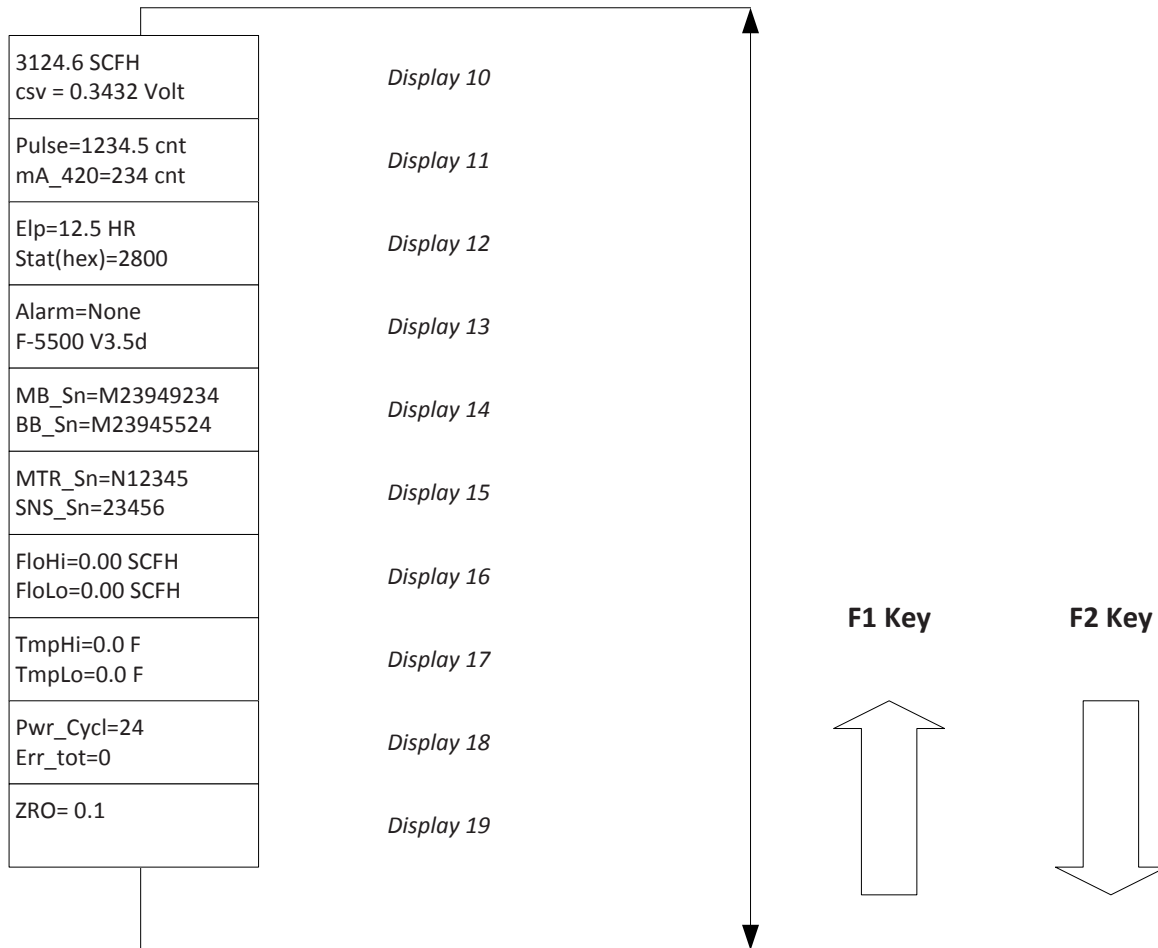

F3 & F4 pressed at the same time will
initiate a "Total" reset

Introduction

Welcome

Thank you for purchasing the Model F-5500 Thermal Gas Mass Flow Meter from ONICON. The Model F-5500 is one of the most technically advanced flow meters in the world. An extensive engineering effort has been invested to deliver advanced features, accurate measurement performance and outstanding reliability.

This Instruction Manual contains the electrical and mechanical installation instructions as well as details for programming, maintaining and troubleshooting the meter. This manual is divided into the following sections: Introduction, Installation, Wiring, Operation, Maintenance, Troubleshooting, Appendices, Glossary and Index.

Product Description**Theory of Operation**

The Model F-5500 is an innovative Thermal Mass Gas Flow Meter and Temperature Transmitter. It is microprocessor-based and field programmable. The F-5500 thermal sensor operates on the law that gases absorb heat. A heated sensor placed in an air or gas stream transfers heat in proportion to the stream's mass flow velocity. There are two sensor elements. One sensor element detects the gas temperature and a second element is maintained at a constant temperature above the gas temperature. The energy applied to the heated sensor to maintain a constant temperature differential (constant ΔT) is directly proportional to the mass flow velocity. The F-5500 flow meter maintains accurate flow measurement over a large temperature and pressure range.

Mass Flow**Mass Flow**

The Model F-5500 measures mass flow; an advantage over other flow meters which measure volumetric flow. Volumetric flow is incomplete because temperature and pressure are unknown and must be measured separately. For example, the mass flow of a gas depends on its temperature and pressure. As temperature and pressure changes, the gas volume changes but not its mass. Therefore a device measuring mass flow is independent of temperature and pressure changes. The Model F-5500 provides a direct measurement of gas flow in mass units (kg/hr, lb/hr), standard units (SCFM, SLPM) or normal units (NM³/hr, NLPM) with no additional temperature or pressure measurements required.

DDC-Sensor™ Technology**DDC-Sensor™ Technology Description**

The ONICON DDC-Sensor™ is a new state of the art sensor technology used in the ONICON Model F-5500 Thermal Gas Flow Meter. The DDC-Sensor™, a Direct Digitally Controlled sensor, is unlike other thermal flow sensors available on the market. Instead of using traditional analog circuitry, the DDC-Sensor™ is interfaced directly to the F-5500 microprocessor for more speed and programmability. The DDC-Sensor™ quickly and accurately responds to changes in process variables by utilizing the microprocessor to determine mass flow rate, totalized flow, and temperature. ONICON's DDC-Sensor™ provides a technology platform for calculating accurate gas correlations.

Introduction

Flow Calibration

Flow Calibration

The ONICON Calibration Lab maintains instrument calibration data on every flow meter. Calibration files include details on process conditions, customer gas, line size and other information. All NIST-traceable equipment utilized for the calibration procedure is identified on the Calibration Certificate, which is sent with every flow meter.

Calibration records include details on process conditions, calibration fluid, line size and other information. All NIST-traceable equipment utilized for the calibration procedure is identified, as is the calibration history of all reference equipment.

In addition to the Calibration Certificate, a certified flow table that correlates current outputs with scaled units of flow is produced for each calibrated device.

I/O Description

I/O Description

The F-5500 features a galvanically isolated 4-20mA analog output with HART communication option and a second output for pulse, RS485 Modbus RTU or BACnet MS/TP. There is also a mini USB port for interfacing with a laptop or computer. The 4-20mA output can be configured for flow rate or process gas temperature and can be scaled by the user. The pulse output can be used for pulse or alarm, is programmable to represent flow rate and can be scaled for units per pulse at a maximum pulse output frequency of 1 Hz.

F-5000 View™ interfaces to the USB port and is a free PC-based software program that displays flow meter readings and permits flow meter configuration. The software is available for download on the ONICON website. Industry standard communication options are available including optional RS485 Modbus RTU, BACnet MS/TP, or HART.

NOTE: the latest version of the F-5000 View software is available for download at <http://www.onicon.com/F5500.html> .



Introduction

Display

F-5500 Functional Diagram

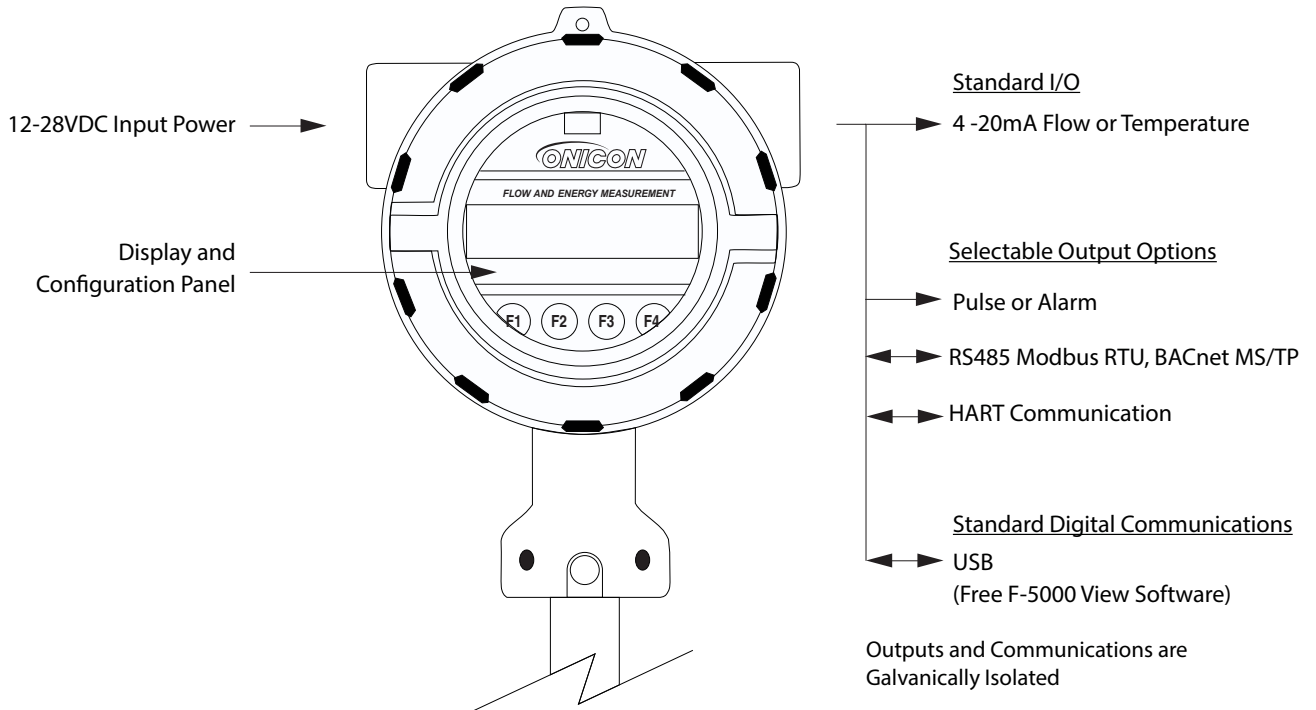

An on-board 2 line x 16 character backlit LCD display shows flow rate, total flow, elapsed time, process gas temperature, and alarms. The display is also used in conjunction with the User Interface for field configuration of flow meter settings such as 4-20mA scaling, frequency output scaling, pipe area, zero flow cutoff, flow filtering or dampening, display configurations, diagnostics, and alarm limits.

Fig. 1.8: F-5500 Function Diagram

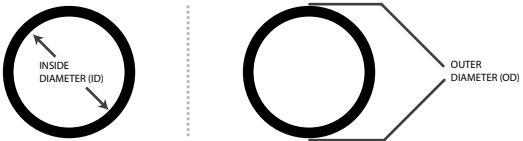
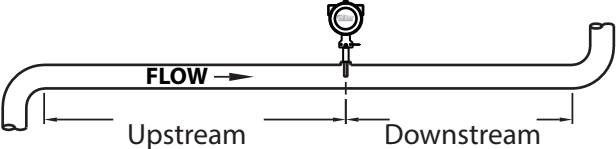
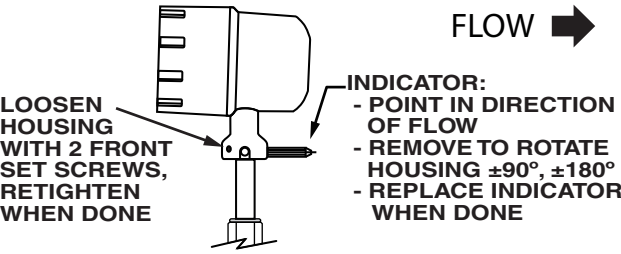
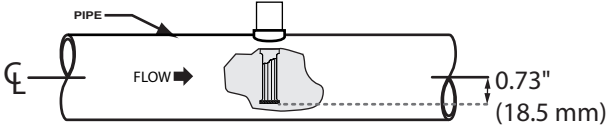
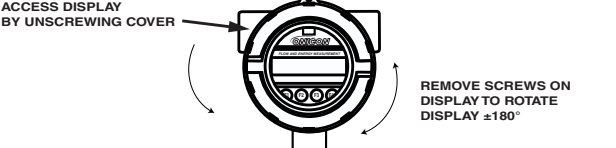
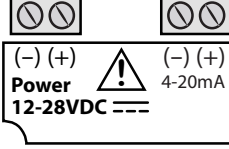
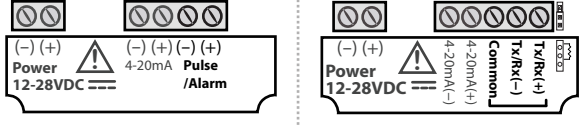

Introduction: Quick Start Guide

Use the table and images below as a guide while using the worksheet on the next page to record your notes.
NOTE: Please read the entire Quick-start procedure before beginning installation.

1.	Record inside diameter (ID). Ensure the actual pipe ID matches the pipe ID shown on the factory calibration certificate. If IDs do not match, refer to p. 52.	
2.	Record upstream and downstream straight-pipe requirements based on tables for insertion (p. 18) and inline (p. 26).	
3.	<p>a. The Flow Direction Indicator must point in the direction of flow.</p> <p>b. The Indicator can also be used to change the orientation of the housing for a better view of the meter's display. Note that the 2 set screws must be loosened before the housing will turn. [refer to p. 21 for more information]</p>	
4.	Ensure correct probe depth setting. If using 1 1/2" size pipe, please see note on p. 22.	
5.	Open the housing. If needed, the orientation of display can be rotated in 90° increments for a better view of the display in tight installations. [refer to p. 28 for more information]	
6.	Ensure power wiring and 4-20mA wiring properly connected [refer to p. 30 - p. 32 for more information]	
7.	Verify you have the proper output signal wiring setup based on model type (Pulse/Alarm or communication protocol) [refer to p. 33 - p. 35 for more information]	
8.	Power on the flow meter	
9.	Check the remaining flow meter settings by accessing the meter settings either through the front panel of the display or by using the F-5000 View™ software tool. Record the settings in the spaces given for items A - D on the following page.	

Introduction: Quick Start Guide

Before powering on your meter, use this worksheet to record your notes.

	Item to verify	Serial Number:	Serial Number:	Serial Number:	Serial Number:
1.	What is the Pipe ID?	ID =	ID =	ID =	ID =
2.	Calculate the Upstream/ Downstream straight-pipe requirements	UP = DN =	UP = DN =	UP = DN =	UP = DN =
3.	a. Is the flow indicator pointed in direction of flow? b. Must the housing be rotated for easy viewing?	Y / N Y / N	Y / N Y / N	Y / N Y / N	Y / N Y / N
4.	Is the probe depth setting correct?	Y / N	Y / N	Y / N	Y / N
5.	Have you rotated the display for easier viewing?	Y / N	Y / N	Y / N	Y / N
6.	Verify proper power wiring setup				
7.	Verify proper output wiring setup				

After powering on your meter, check items A - D below by accessing the meter settings either through the front panel of the meter's display or by using the F-5000 View software tool.

A.	Which flow units have been set in meter? (SCFH, KG/H, etc..)				
B.	Correct values for reference temperature and pressure?	Y / N	Y / N	Y / N	Y / N
C.	Confirm the pipe ID listed above same as "Pipe_id="				
D.	Verify the 4mA and 20mA meter settings	4mA = 20mA =	4mA = 20mA =	4mA = 20mA =	4mA = 20mA =

Your Notes:

If you are experiencing any problems after completing this procedure, please call the ONICON Service Department at 727-447-6140 to review this information.

Installation: General

Installation - Model F-5500 Flow Meter

Scope

This section describes how to install the ONICON Model F-5500 Flow Meter and how to get started:

1. Determine lateral position on the pipe
2. Sensor installation depth
3. Sensor orientation in relation to sensor length and direction of flow
4. Proper tightening of compression fitting for mounting meter

Installation procedures must be performed using a combination of the end user's best engineering practices, in compliance with local codes, and manufacturer's recommendations.

General Precautions

The following general precautions should be observed:

1. Exercise care when handling the flow meter to avoid damaging the probe, sensor or enclosure.
2. The enclosure cover must be closed except during installation or configuration.
3. Mounting F-5500 in direct sunlight can cause the temperature inside the enclosure to increase beyond design limits, resulting in failure of LCD display and reduced component life. It is recommended that a sunshade be installed to avoid direct sunlight (see maximum enclosure operating temperature specification in appendix).
4. Ensure the flow direction indicator/pointer for the meter is in line with the direction of flow in the pipe.
5. Do not install the F-5500 enclosure near an igniter, igniter-controller or switching equipment.
6. Do not install an external power supply in a cabinet containing an igniter controller or switching equipment.
7. For accurate flow measurement: review flow meter placement instructions before installation to ensure a proper flow profile in the pipe.



Installation: Insertion Type

Insertion Flow Meter Lateral Placement

Instructions for Insertion Flow Meter Lateral Placement

Install the Model F-5500 Insertion style flow meter so that it is far enough away from bends in the pipe, obstructions, or changes in line sizes to ensure a consistent flow profile. Review straight run requirements table on p. 21.



NOTE: The probe diameter is 3/4".

Fig. 2.1: Upstream and Downstream Pipe IDs for Insertion Meters

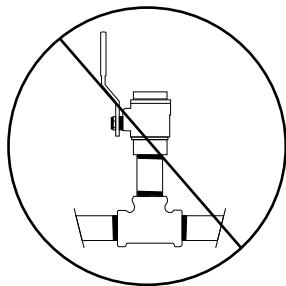
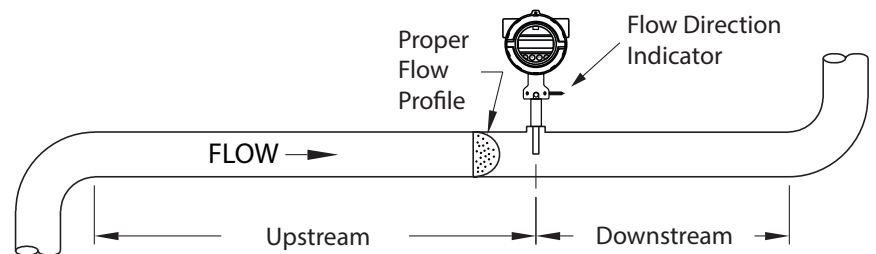

Do not substitute threaded tees for the welded branch outlet. Contact ONICON if you need installation hardware for threaded pipe.

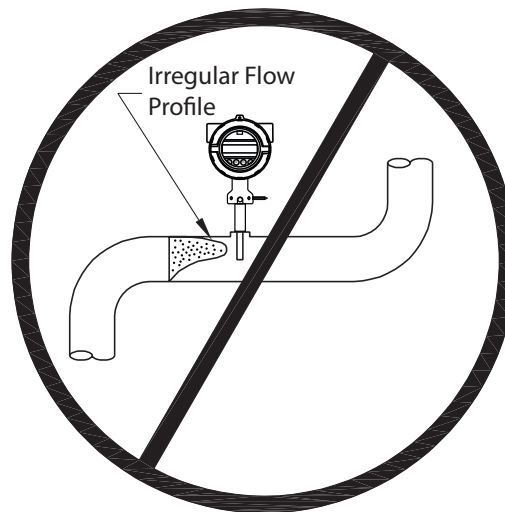

NOTE: An irregular flow profile may affect sensor accuracy.

Special Conditions of Use:

- Consult the manufacturer if dimensional information on the flameproof joints is necessary.
- The flamepaths of the equipment are not intended to be repaired. Consult the manufacturer if repair of the flamepath joints is necessary
- Follow the manufacturer's instructions to reduce the potential of an electrostatic charging hazard.

Installation: Insertion Type

Installation Hardware

Installation Hardware

ONICON F-5500 Insertion Thermal Mass Flow Meters employ a process adapter fitting design that allows for insertion and removal, when necessary, without interrupting flow and draining the pipe. To take advantage of this feature, the flow meter must be installed through an isolation valve. The installation must allow for sufficient overhead clearance to fully extract the meter, and a full 7/8" opening in the pipe wall is required to clear the sensor head and allow for insertion. Make sure that your valves and fittings are full port and at least 1" in actual internal diameter.

Fig. 2.2: Installation Requirements

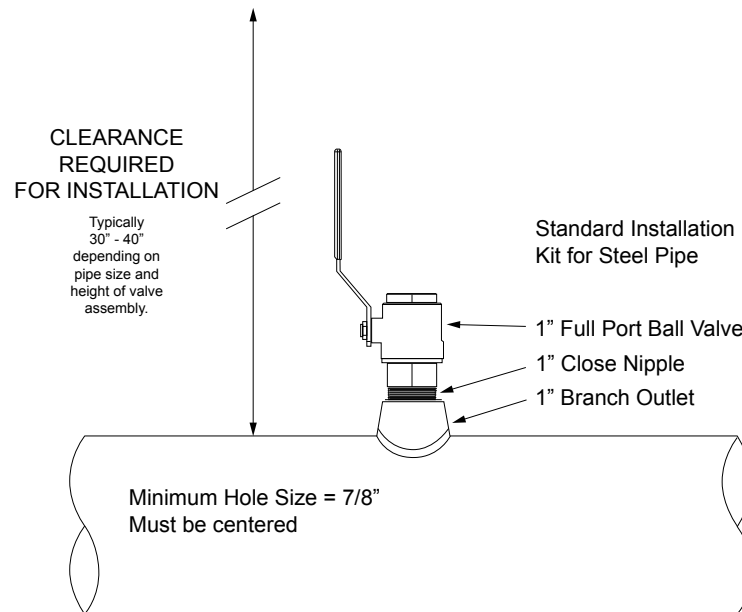

CAUTION! ONICON insertion style flow meters must be installed through a valve assembly. Failure to do so negates the ability to remove the meter without shutting down and draining the system. It will also result in an excessive amount of stem protruding from the pipe. Excessive stem lengths unnecessarily expose the meter to incidental damage.



Flow Conditioners

NOTE: Flow meters installed through oversized access holes will be subjected to undesirable turbulence that may affect the accuracy of the meter.

Flow Conditioners

Flow conditioners may be required when an insufficient straight run of pipe is available upstream of the proposed sensor location. ONICON provides flow conditioners as an optional accessory.

Installation: Insertion Type

Flow
Conditioners

Fig. 2.3: Placement of Optional Flow Conditioners in Pipe

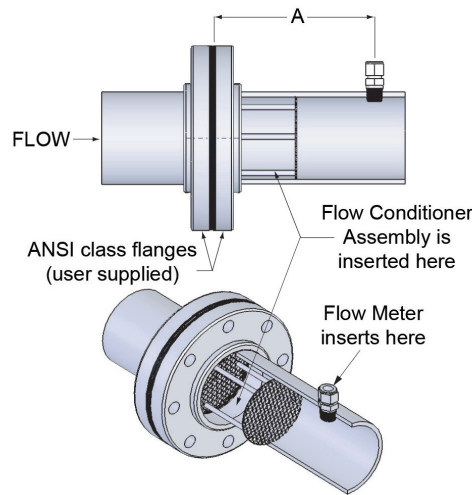

Schedule 40 Flow Conditioners	
Nom. Dia.	Dimension A
1½"	6.00"
2"	6.00"
2½"	9.00"
3"	9.00"
4"	9.00"
6"	12.00"

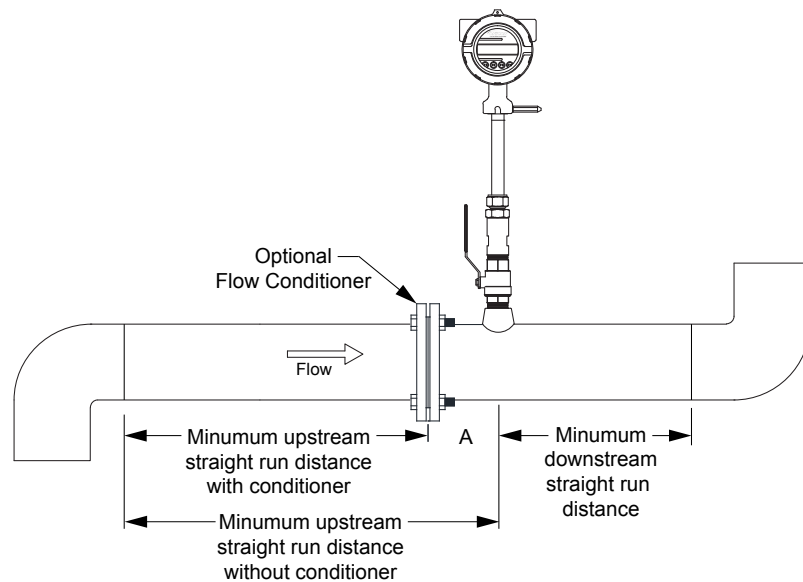

ONICON flow conditioners are designed to be installed between two flanges (provided by installer) that are located a specific distance upstream of the flow sensor. The use of flow conditioners significantly reduces the upstream straight pipe length requirement for flow sensor. The size of the flow conditioner must match the pipe size. Contact ONICON for Schedule 80 flow conditioners.

Installation: Insertion Type

Fig. 2.4: Straight Run Requirements for Upstream Obstructions - Insertion

Upstream obstruction	Straight run required upstream of meter location without flow conditioner	Straight run required upstream of flow conditioner mounting flange	Straight run required downstream of meter location
Single bend preceded by ≥ 9 diameters of straight pipe	15 Diameters	3 Diameters	5 Diameters
Pipe size reduction in straight pipe run	15 Diameters	3 Diameters	5 Diameters
Multiple bends in plane with < 9 diameters of straight pipe between them	20 Diameters	9 Diameters	5 Diameters
Pipe size expansion in straight run	30 Diameters	10 Diameters	5 Diameters
Tees	30 Diameters	10 Diameters	5 Diameters
Multiple bends out of pipe	40 Diameters	10 Diameters	5 Diameters
Modulating or regulating valve	40 Diameters	10 Diameters	5 Diameters



NOTE: Always use the maximum available straight run. When more than the minimum required straight run is available place the meter such that the excess straight run is upstream of the meter location.

Sensor Orientation Direction of Flow

Fig. 2.5: Orientation of Flow Meter

Install the flow meter with the flow direction indicator pointing in the direction of flow in the pipe.

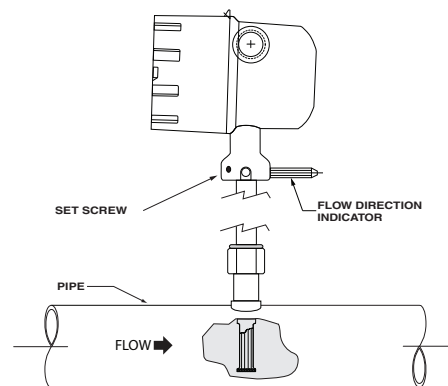

Sensor Element Alignment

Sensor Element Alignment

Every F-5500 flowmeter is equipped with equal length sensor elements. To be sure that the flowmeter elements are lined up correctly in the process stream, please refer to "Fig. 2.5: Orientation of Flow Meter" and be sure that the Flow Direction Indicator is pointing in the direction of flow in the pipe.

Fig. 2.6: Sensor Elements

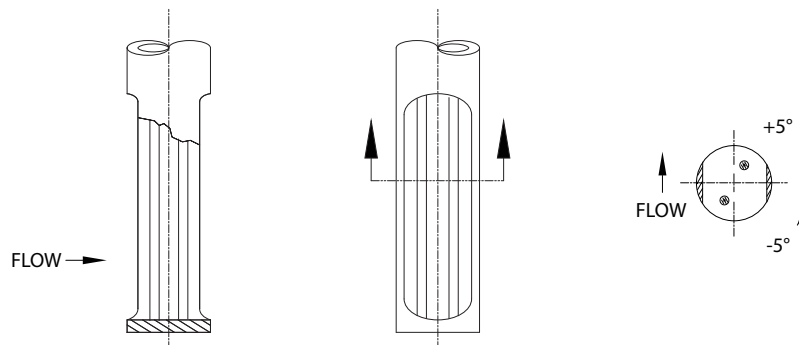

NOTE: Rotational misalignment must not exceed $\pm 5^\circ$.



Installation: Insertion Type

Installation Procedure

Installing the Sensor

There are two different versions of the insertion style F-5500. The standard version and the high pressure version are shown below.

Fig. 2.7a: Standard F-5500

Fig. 2.7b: High Pressure F-5500

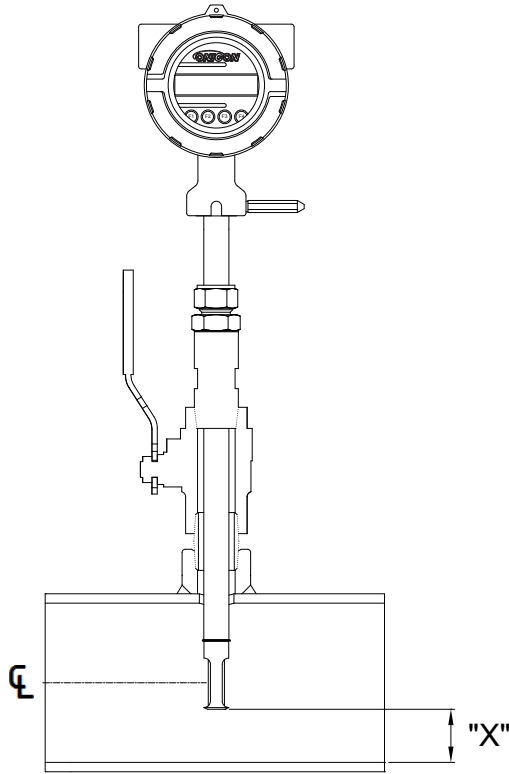

The standard version of the F-5500 is hand insertable into pipes with operating pressures up to 60 psig.

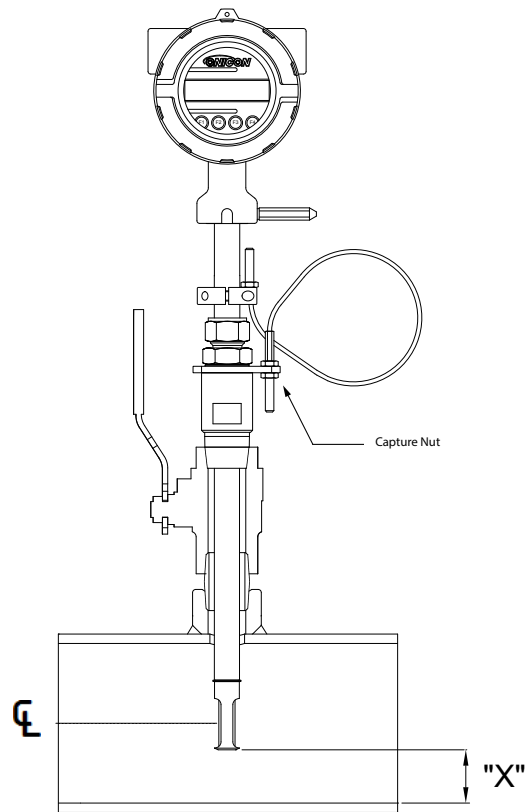

The high pressure version of the F-5500 is hand insertable up to 100 psig. For applications above 100 psig, it is necessary to isolate flow and relieve pressure before attempting to install or remove the meter. The maximum operating pressure for this version of the meter is 150 psig.

Installation Procedure

The installation depth of the sensor in the pipe is dependent on the pipe size. To get the most accurate reading, proper placement of the sensor window within the pipe is necessary. Use the following procedure to determine the proper depth setting for your meter. The procedure is valid for nominal pipe sizes of 1.5" through 8". The maximum allowable height of the installation hardware (branch outlet, close nipple & ball valve) is 6" as measured from the outside wall of the pipe to the top of the valve.

Installation: Insertion Type

Installation Procedure

Procedure:

1. Locate the pipe ID listed on the calibration information label on the side of the flow meter enclosure. This information is also available on the calibration certificate.
2. Confirm that this inside diameter (ID) corresponds to the nominal diameter of the pipe where the meter is installed.
 - a. To determine the nominal pipe size, measure the circumference of the pipe without the insulation and divide this value by pi (3.14). This will give you the outside diameter (OD).
 - b. Use the table on the following page to locate the nominal pipe size and ID based on the OD
 - c. The table provides dimensions for common schedule 40 and schedule 80 pipes.
 - d. Contact ONICON for assistance if your pipe dimensions are not shown.
3. Once the ID is confirmed, prepare to insert the flow sensor by ensuring the compression fitting is loose.
4. Thread the process adapter fitting on to the ball valve and tighten. Use the appropriate thread sealant, as required, to ensure a leak free connection.
5. Open the ball valve and carefully insert the flow sensor until the end of the stem just contacts the opposite wall of the pipe.
6. Mark the position of the stem where it exits the top of the compression fitting.
7. Withdraw the stem "X" distance as measured from the top of the compression fitting. At the same time, position the electronics enclosure parallel to the pipe in the correct orientation relative to the flow direction as shown in "Fig. 2.5: Orientation of Flow Meter" on page 21. This will position the sensor with its axis in line with the flow and in the correct direction.
8. Read the instructions on the next page before tightening the compression fitting.
 - - FOR METERS WITH THE HIGH PRESSURE SAFETY CABLE - -
9. Once the compression fitting is tight, attach the safety cable using the capture nut provided.
10. If necessary, rotate the top clamp to re-align the cable with the bottom clamp.
 When rotating the clamp, make sure that it remains at the top of the stem pressed firmly against the spacer. (see appendices for details).

* refer to model number coding to determine the stem length of your meter.

Nominal Dia.	OD	ID		X		Minimum Stem Length*
		Schedule 40	Schedule 80	Schedule 40	Schedule 80	
1 ½"	1.900"	1.610"	1.500"	Always Use 0.1"		15"
2"	2.375"	2.067"	1.939"	0.304"	0.240"	15"
2 ½"	2.875"	2.469"	2.323"	0.505"	0.432"	15"
3"	3.500"	3.068"	2.900"	0.804"	0.720"	15"
4"	4.500"	4.026"	3.826"	1.283"	1.183"	15"
6"	6.625"	6.065"	5.761"	2.303"	2.151"	18"
8"	8.625"	7.981"	7.625"	3.261"	3.083"	18"

Installation: Insertion Type

Compression Fittings

Compression Fittings

While holding the fitting body steady, finger tighten the nut. Then, tighten the nut with wrenches an additional one and one-quarter (1 1/4) turn. If beginning at 6 o'clock, the wrench would make one full turn back to 6 o'clock and rest at the 9 o'clock position for proper compression. See Figure 2.9 below.



CAUTION! Tightening the compression fitting will crimp the fitting to the stem of the flow meter and lock the depth setting into place. Don't tighten the compression fitting until you've completed all steps in the installation section of this manual.

Fig. 2.8: Proper Tightening of the Compression Fitting Nut

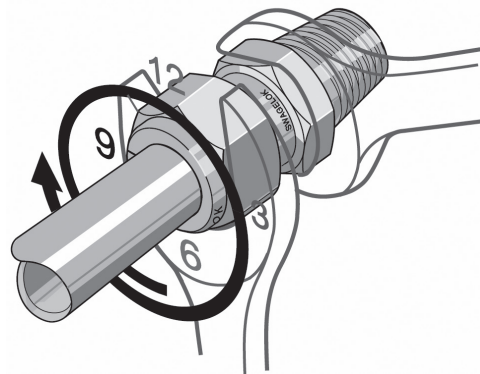

Rotating the Enclosure

Rotating the Enclosure

The Model F-5500 has been designed to allow the enclosure to rotate into four positions for optimal viewing of the display. To rotate the enclosure, first loosen the two set screws near the Flow Direction Indicator. Then unscrew and remove the Flow Direction Indicator to allow the enclosure to swivel into the desired position. Then screw the Flow Direction Indicator back into its place, ensuring that it points in the direction of flow, and tighten the set screws.

Fig. 2.9: Orientation of Flow Meter, Rotating Enclosure

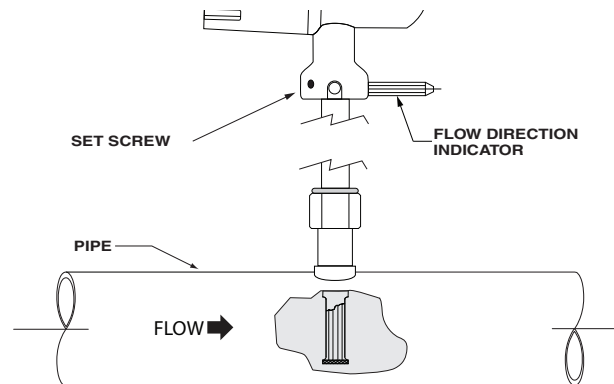

Install the meter with the flow direction indicator pointing in the direction of flow in the pipe.

Installation: Insertion Type

Removing the Meter



Removal of the Meter

Follow these instructions for safe removal of the meter from the pipe.

WARNING! SYSTEM MAY BE UNDER HIGH PRESSURE.

Do not attempt to remove meters with the standard process adapter fitting from a pipe pressurized above 60psig without first relieving pressure in the pipe.

Do not attempt to remove any meter with the high pressure process adapter fitting and cable assembly from a pipe pressurized above 100 psig without first relieving pressure in the pipe.



WARNING! When removing the flow meter, be sure to hold the electronics enclosure firmly by hand before unscrewing the compression fitting nut. Failure to do this will allow the pressure in the pipe to suddenly and rapidly force the meter from the pipe potentially causing serious injury. The meter could also be damaged resulting in a loss of gas from the pipe. The force required to hold the meter will be 0.44 times the pipe pressure. If you are unsure of your ability to hold the meter for any reason, do not loosen the compression fitting nut.

Procedure:

1. Slowly unscrew the compression fitting nut while maintaining a firm grip on the enclosure to counteract the effect of pressure in the pipe.
2. Once the nut is fully disengaged from the threads, the meter will be free to move. Carefully withdraw the flow meter stem from the pipe until the sensor head is fully inside the process adapter fitting.
3. After the meter is completely withdrawn, slowly close the valve to isolate flow.

NOTE: At this point, the flow meter is isolated from the pipe, but the process adapter fitting will contain a small volume of process gas under pressure.

4. After the valve is completely closed, slowly unscrew the compression fitting from the top of the process adapter fitting leaving the adapter fitting on the ball valve.

NOTE: As the compression fitting is removed, pressure will be vented from the ball valve.

5. For meters provided with the high pressure process adapter fitting, disconnect the safety cable at the bottom by removing the capture nut (refer to Fig. 2.7b). Be sure to fully re-attach the nut to the cable once the meter is removed from the pipe.

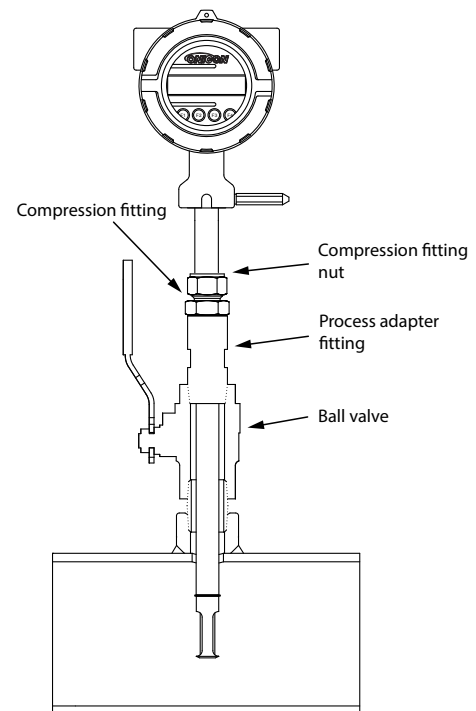

Installation: Inline Type

Flow Meter
Placement
Inline Type

Instructions for Inline Flow Meter Placement

Install the Model F-5500 Inline style flow meter so that it is far enough away from bends in the pipe, obstructions, or changes in line sizes to ensure a consistent flow profile. Review the straight run requirements table on p. 27.

The Model F-5500 is threaded or flanged to the customer's pipe. Care should be taken to ensure that the diameter of the mating pipe is the same diameter as the Model F-5500 flow body or errors in flow readings can occur. The installation procedure should be a combination of the end user's best engineering practices, in compliance with local codes, and the manufacturer's recommendations.

See "Fig. 2.11: Straight Run Requirements for Upstream Obstructions - Inline" on page 27 for a detailed look at upstream and downstream pipe diameters for inline meters.

Fig. 2.10: Upstream and Downstream Pipe IDs for Inline Meters

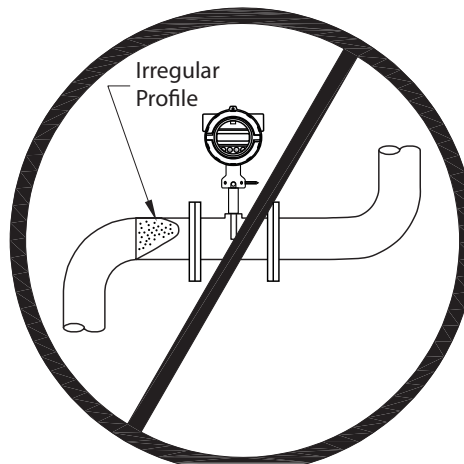
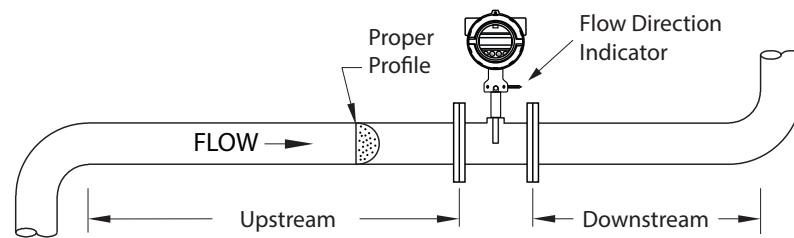

Installation: Inline Type

Upstream Obstructions

Fig. 2.11: Straight Run Requirements for Upstream Obstructions - Inline

Upstream obstruction	Minimum straight run required upstream of flow meter process connection based on the nature of the upstream obstruction								
	¾"	1"	1 ¼"	1 ½"	2"	2 ½"	3"	4"	6"
Single bend preceded by ≥ 9 diameters of straight pipe OR Pipe size reduction in straight pipe run	2.25"	3"	3.75"	4.5"	6"	7.5"	9"	12"	18"
Multiple bends in plane with < 9 diameters of straight pipe between them OR Pipe size expansion in straight run	6.75"	9"	11.25"	13.5"	18"	22.5"	27"	36"	54"
Tees	7.5"	10"	12.5"	15"	20"	25"	30"	40"	60"
Multiple bends out of plane	7.5"	10"	12.5"	15"	20"	25"	30"	40"	60"
Modulating or regulating valves OR Diaphragm or roots type utility meters	9"	12"	15"	18"	24"	30"	36"	48"	72"
	Minimum downstream straight run required after flow meter process connection								
	2.25"	3"	3.75"	4.5"	6"	7.5"	9"	12"	18"

Flow Body Orientation Inline Type

Inline Orientation

Install the flow body so that the flow indicator is pointing in the direction of flow.

Fig. 2.12: Orientation of an Inline Meter - Flow Direction Indicator

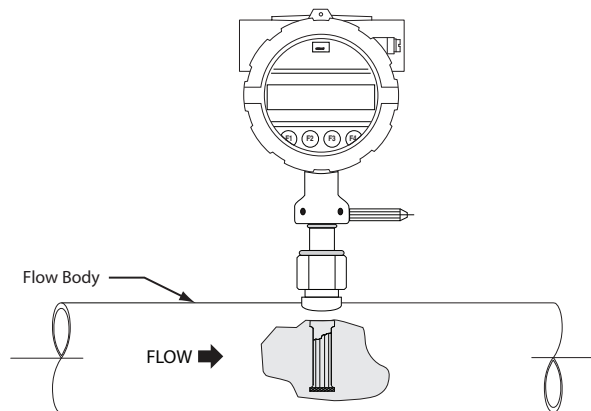

NOTE: ONICON does not supply gaskets for this product.

Installation: Inline Type

Changing Display Orientation

Changing the Orientation of the F-5500 Display

The display can be rotated in 90° increments for optimal viewing of the screen. First, open the enclosure by unscrewing the enclosure cap and loosen the two captive phillips screws to open the display assembly. Detach the display board from the metal shield by loosening the three screws on the back of the round shield. Rotate the display board to the desired orientation. Ensure that the display cable is routed flat and straight through the display hinge to prevent binding. Reattach the display board to the metal shield by tightening the three screws. Close the display assembly and secure it to the enclosure with the two captive screws. Finally, install the enclosure cover back on the front of the enclosure.

Fig. 2.13 - Accessing Wiring Terminals or Rotating the Display

Loosen these two screws to open the display and access wiring terminals.

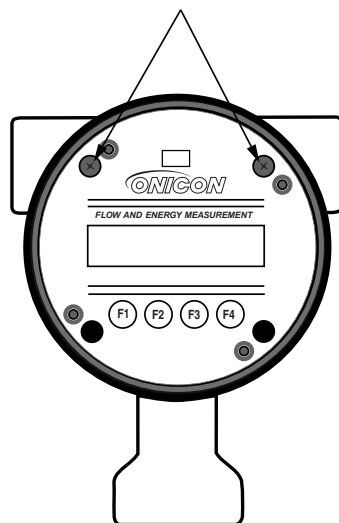

Loosen these three screws to rotate the display in 90° increments ($\pm 180^\circ$).

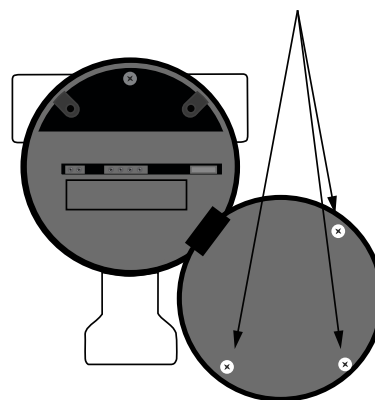



Wiring: General

Scope

Wiring Instructions

To wire the F-5500, unscrew and remove the enclosure cap and loosen the two captive screws on the display assembly. Rotate it open to access the wiring terminals. Refer to "Fig. 2.13 - Accessing Wiring Terminals or Rotating the Display" on page 28 for location of screws.

Connect the power and signal wires to the terminal blocks according to the label and instructions on the following pages.

Cut all wires as short as allowable for a minimum service loop. Obtain the correct length for the F-5500 wires using one of these methods:

- Trim the wires to extend 2 inches out of the enclosure after the conduit and wires are routed to the F-5500.
- Trim the wires to extend 5 inches from the end of the conduit before attaching them to the F-5500.

Precautions



Wiring Precautions - WARNING!

- Do not open the enclosure when energized or an explosive atmosphere is present.
- Connect earth ground to a chassis ground screw on the inside or outside of F-5500 enclosure to reduce the potential of an electrostatic charging hazard.
- All plumbing and electrical installations of flow meters must be in compliance with local codes, the end user's best engineering practices, and manufacturer's recommendations.
- Do not install the F-5500 enclosure near an igniter, igniter-controller or switching equipment to eliminate the possibility of noise interference.
- Do not install an external power supply in a cabinet containing an igniter controller or switching equipment.
- This flow meter contains components that can be damaged by static electricity. You must discharge yourself by touching a grounded steel pipe or other grounded metal prior to working inside this flow meter.
- Close any unused conduit entries using suitably certified plugs

Power Wiring

Power Wiring

For wiring the 12 to 28VDC power, use stranded copper wire, no larger than 16-gauge. Twisted pair shielded cable is recommended. Supply connection wiring must be rated for at least 90°C.

Grounding

Grounding

The enclosure must be properly grounded with a quality earth ground. 16 gauge, stranded wire is recommended.

Signal Wiring

Signal Wiring

For signal and serial communication wiring, the recommended wire gauge is 18 to 22 AWG. Always use twisted pair shielded cable.



Wiring: Input Power

Power Input Wiring

Power Input Requirements: 12 to 28VDC Supply

External DC power supply must provide 12 to 28VDC (10 to 30VDC full input power range) at 6 Watts minimum.

(With 12VDC power, the F-5500 can use up to 500mA. With 24VDC power, the F-5500 can use up to 250mA.)

A 20 Watt or greater power supply is recommended to ensure it can provide enough current under all temperature, ventilation and power on conditions.

The enclosure must be properly grounded with a quality earth ground. Sixteen (16) gauge, stranded wire, is recommended for power and earth ground.

Fig. 3.1: Connections for 12 to 28VDC Supply

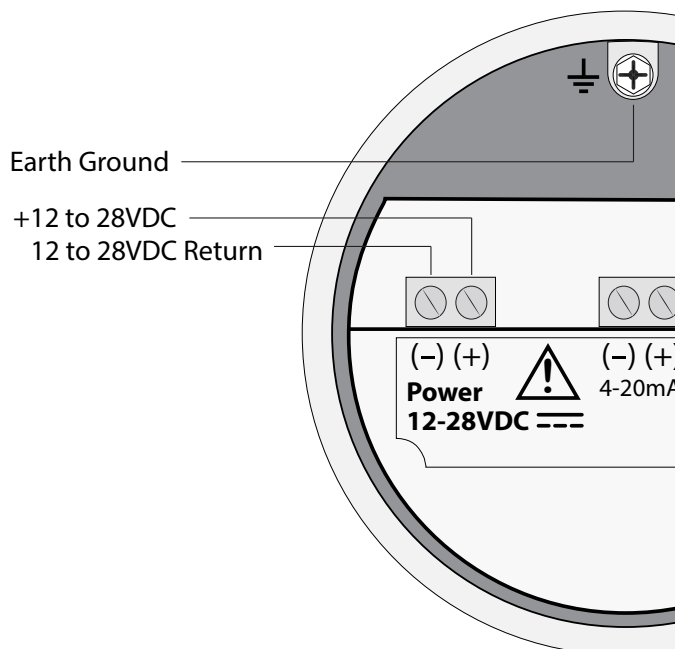

CAUTION!

- Supply connection wiring must be rated for at least 90°C.

Wiring: Signal Wiring



4-20mA Loop
Power Provided
by Customer
(Recommended)

4-20mA Output Wiring: Customer-Supplied Power Source

Bring the 4-20mA wiring in through either conduit hub. Connect 4-20mA wiring as shown in the diagram below.

Fig. 3.2: 4-20mA Output Wiring for Customer-Supplied Power Source

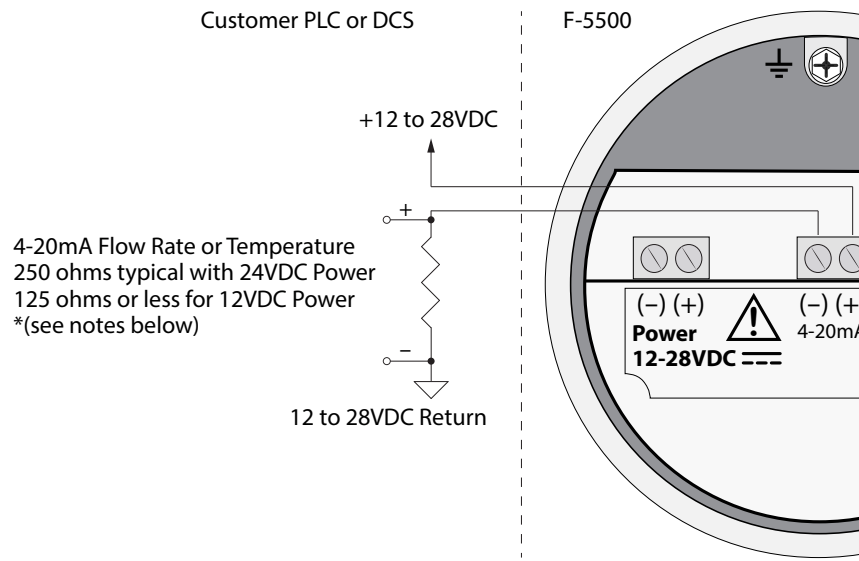

WIRING



IMPORTANT NOTES:

- When using a 12 volt power supply, the load resistor on the 4-20mA output must be 125 ohms or less to operate properly.
- When using 24 volt power, the load resistor is typically 250 ohms. A 250 ohm resistor in the 4-20mA circuit will result in a 1 to 5 volt signal to the PLC or DCS.
- When using a 24 volt power supply, the load resistor on the 4-20mA output must be 600 ohms or less.
- Some PLC and DCS equipment have built in load resistors, please refer to the technical manuals of such equipment.



Wiring: Signal Wiring

4-20mA
Loop Power
Provided by
F-5500

4-20mA Output Wiring: Loop Power Provided by F-5500

Bring the 4-20mA wiring in through either conduit hub. Connect the 4-20mA as shown in the diagram below.

Fig. 3.3: 4-20mA Output Wiring for Loop Power Provided by F-5500

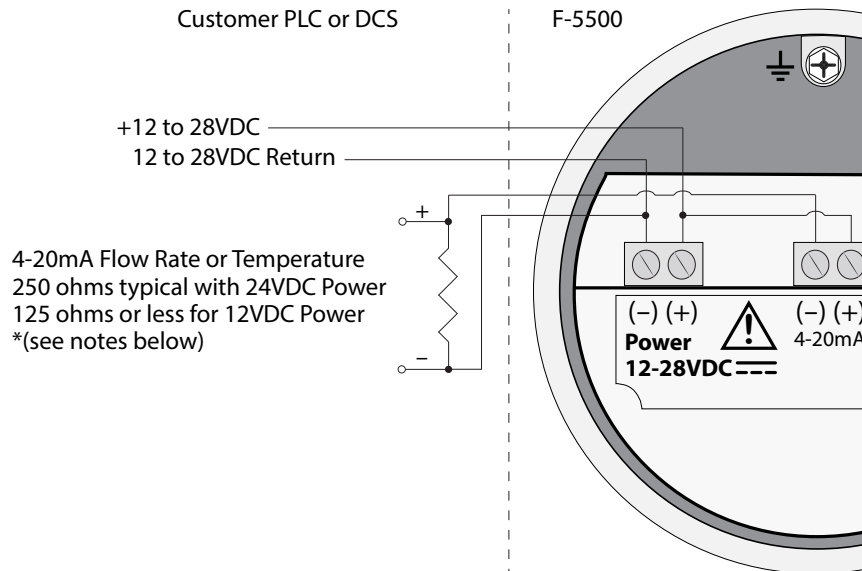

4-20mA Flow Rate or Temperature
250 ohms typical with 24VDC Power
125 ohms or less for 12VDC Power
*(see notes below)

IMPORTANT NOTES:

- When using a 12 volt power supply, the load resistor on the 4-20mA output must be 125 ohms or less to operate properly.
- When using 24 volt power, the load resistor is typically 250 ohms. A 250 ohm resistor in the 4-20mA circuit will result in a 1 to 5 volt signal to the PLC or DCS.
- When using a 24 volt power supply, the load resistor on the 4-20mA output must be 600 ohms or less.
- Some PLC and DCS equipment have built in load resistors, please refer to the technical manuals of such equipment.



Wiring: Pulse/Alarm Wiring



Pulse/Alarm Output Wiring:

Pulse/Alarm Output Wiring: Customer Supplied Power Source (Recommended)

Bring pulse/alarm wiring in through either conduit hub. Connect as shown in the diagram below. The pulse/alarm output is an open collector circuit capable of sinking a maximum of 10mA of current. Pulse or alarm selection is programmed using the display or F-5000 View. Only one option, pulse or alarm, can be active at a time. The pulse output is normally low (open collector output closed) and pulses high +12 to 24VDC (open collector output open) for 500 milliseconds when the total flow is measured. The maximum frequency setting of the pulse output is 1 Hz.

When the output is configured for Alarm, the open collector output will be open when there is no alarm and closed when an alarm is present.

Fig. 3.4: Pulse/Alarm Output Isolated (Recommended)

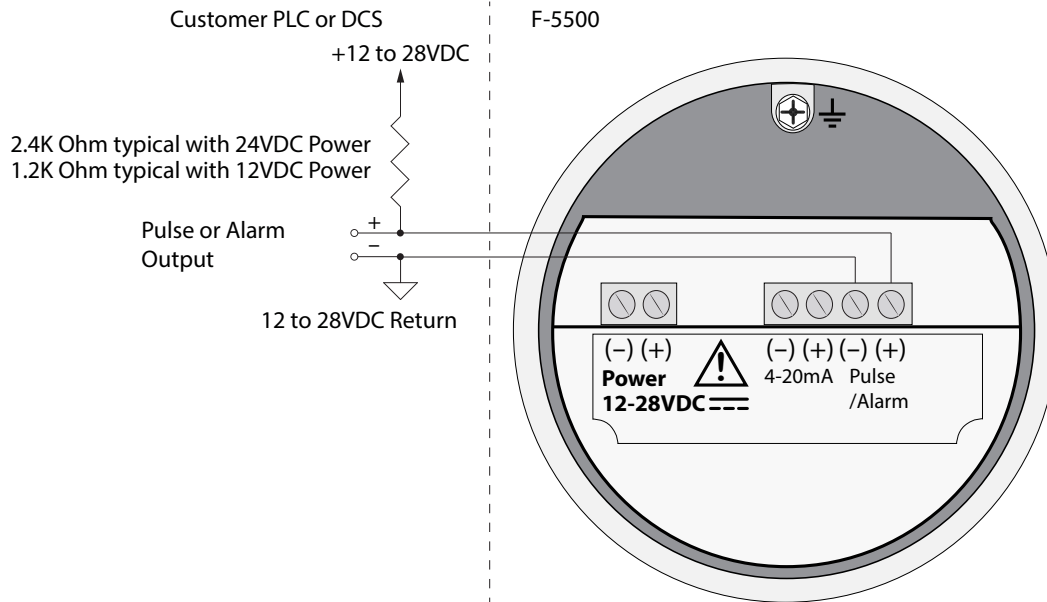

WIRING



IMPORTANT NOTES:

- The F-5500 Pulse/Alarm output is typically used to drive digital circuitry or solid-state relays. The output of a solid state relay may, in turn, operate loads such as electromechanical relays or alarm indicators.
- The maximum load current of the Pulse/Alarm output is 10mA. Choose a load resistance that provides approximately 10mA with the power supply operating voltage.
- When the output is configured for Alarm and an alarm is not active, the output will be closed (0 volts output). When an alarm is active, the output will be open (12 to 28 volts output).
- In order to use the Pulse/Alarm feature on the Model F-5500, this feature must be chosen when the meter is ordered from the factory. Pulse output not available with meters ordered with RS485 Modbus RTU and BACnet MS/TP.



Wiring: Pulse/Alarm Wiring

Pulse/Alarm Output Wiring

Pulse/Alarm Output Wiring: Power Provided by F-5500

Bring pulse/alarm wiring in through either conduit hub. Connect as shown in the diagram below. The pulse/alarm output is an open collector circuit capable of sinking a maximum of 10mA of current. Pulse or alarm selection is programmed using the display or F-5000 View. Only one option, pulse or alarm, can be active at a time.

When the output is configured for Alarm, the open collector output will be open when there is no alarm and closed when an alarm is present.

Fig. 3.5: Pulse/Alarm Output Power Provided by F-5500

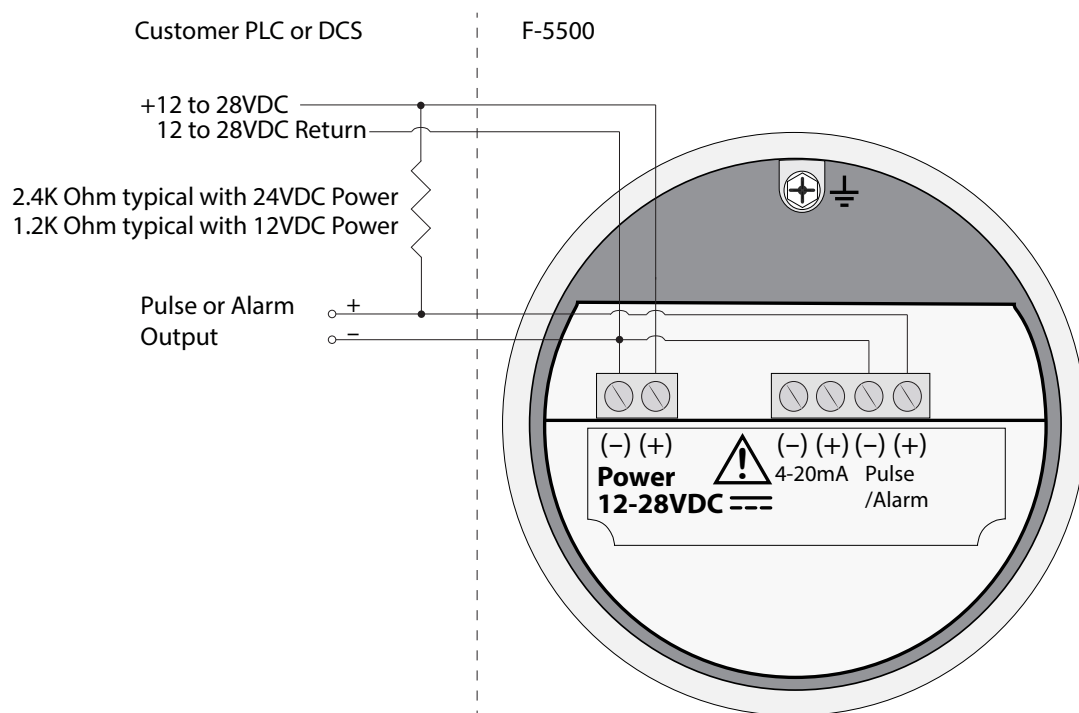

IMPORTANT NOTES:

- The F-5500 Pulse/Alarm output is typically used to drive digital circuitry or solid-state relays. The output of a solid state relay may, in turn, operate loads such as electromechanical relays or alarm indicators.
- The maximum load current of the Pulse/Alarm output is 10mA. Choose a load resistance that provides approximately 10mA with the power supply operating voltage.
- When the output is configured for Alarm and an alarm is not active, the output will be closed (0 volts output). When an alarm is active, the output will be open (12 to 28 volts output).
- In order to use the Pulse/Alarm feature on the Model F-5500, this feature must be chosen when the meter is ordered from the factory. Pulse output not available with meters ordered with RS485 Modbus RTU and BACnet MS/TP.

Wiring: RS485 Modbus RTU or BACnet MS/TP



RS485 Wiring

RS485 Wiring for RS485 Modbus RTU or BACnet MS/TP

Wiring connections are made as shown in the diagram below for Modbus or BACnet communication.

Termination Resistor

Connect a termination resistor across the receive/transmit signals of the last device on the communication line. To connect the 120 ohm termination resistor on the F-5500, set jumper W1 to the TERM position.

Disconnect the termination resistor on all other external RS485 devices. The termination resistor of the F-5500 is disconnected by setting jumper W1 to the OPEN position.

Fig. 3.6: RS485 Wiring

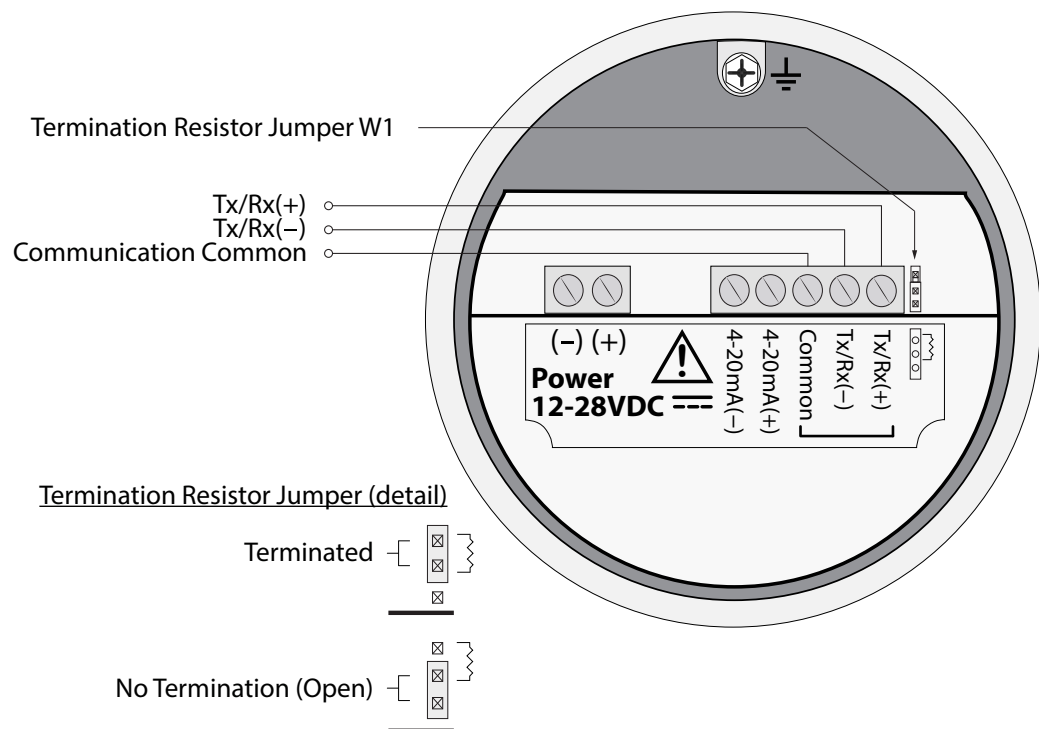

WIRING



IMPORTANT NOTE:

- In order to use the RS485 feature on the Model F-5500, this feature must be chosen when the meter is ordered from the factory. Modbus RTU and BACnet MS/TP are not available with meters ordered with the Pulse/Alarm option.
- W1 jumper will be shipped in the open or unterminated position. It should be in the terminated position on the last meter in the series.



Wiring: HART

HART Wiring

HART Wiring

The HART connections are accessed by removing the cover of the F-5500 enclosure.

HART 4-20mA Output Wiring: Customer-Supplied Power Source

The 4-20mA current loop and HART modem connections are made as shown in the diagram below.

Fig. 3.7: HART Wiring, Customer-Supplied Power Source

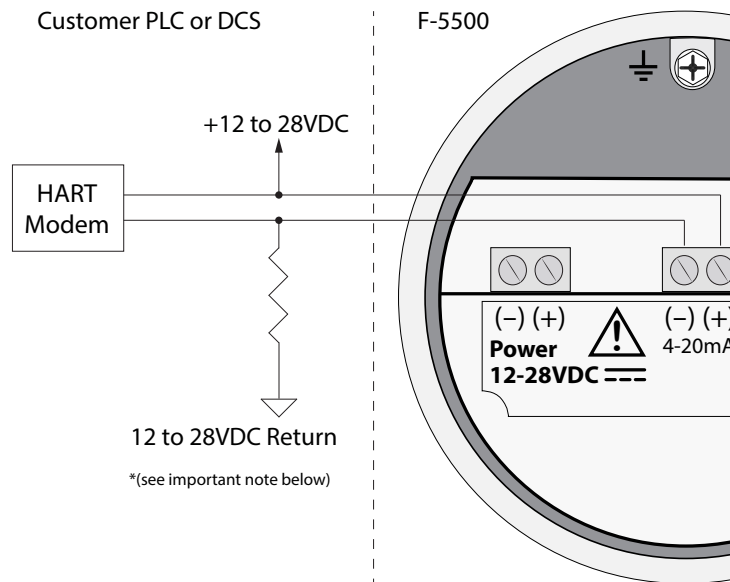

Fig. 3.7, IMPORTANT NOTE:

The load resistor on the ONICON Flow Meter 4-20mA signal is typically 250 ohms and is located in or at the customer's PLC or DCS. A 250 ohm resistor in the 4-20mA line will result in a 1 to 5VDC signal to the PLC or DCS. Some PLC/DCS equipment has the load resistor built in to the unit; please refer to the PLC/DCS technical manual. **Do not exceed a 600 ohm load on the ONICON Flow Meter 4-20mA signal.**

Fig. 3.8-3.9, IMPORTANT NOTES:

- When using a 12 volt power supply, the load resistor on the 4-20mA output must be 125 ohms or less to operate properly.
- When using 24 volt power, the load resistor is typically 250 ohms. A 250 ohm resistor in the 4-20mA circuit will result in a 1 to 5 volt signal to the PLC or DCS.
- When using a 24 volt power supply, the load resistor on the 4-20mA output must be 600 ohms or less.
- Some PLC and DCS equipment have built in load resistors, please refer to the technical manuals of such equipment.



Wiring: HART



HART 4-20mA Wiring

HART 4-20mA Output Wiring: Handheld Communicator

The 4-20mA current loop connections are made as shown in the diagram below.

A hand-held HART communicator can be connected to test points TP12 (+) and TP13 (-) with clip leads or to the 4-20mA terminal block.

Fig. 3.8: HART 4-20mA Output Wiring, Handheld Communicator

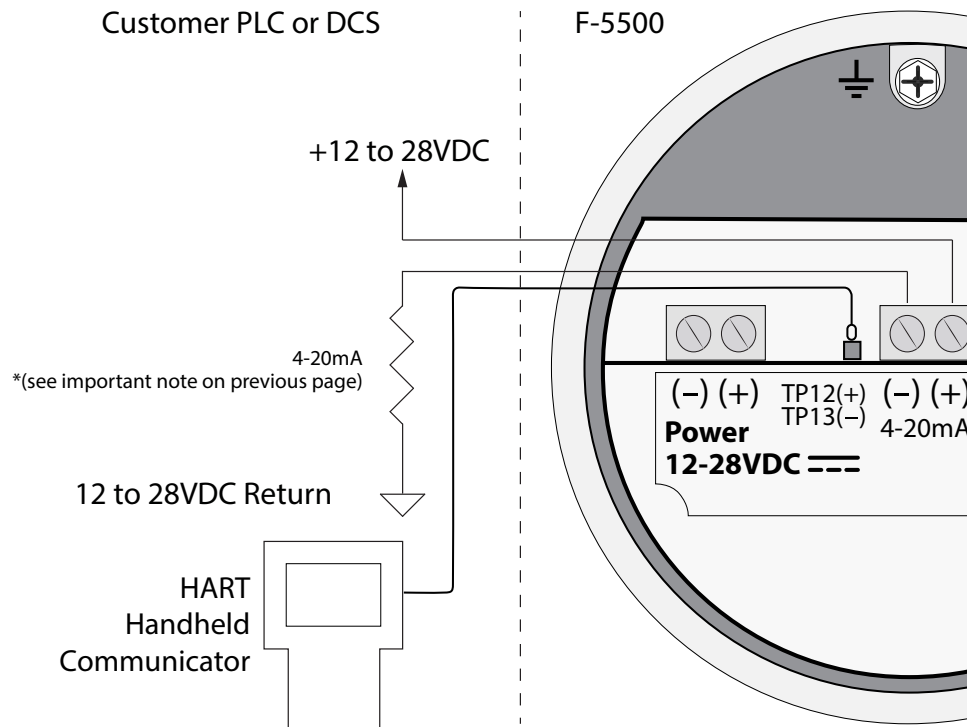

Wiring: HART

HART 4-20mA
Wiring

HART 4-20mA Output Wiring: Loop Power Provided by F-5500

The 4-20mA current loop and HART modem connections are made as shown in the diagram below.

Fig. 3.9: HART 4-20mA Output Wiring, Loop Power Provided by F-5500

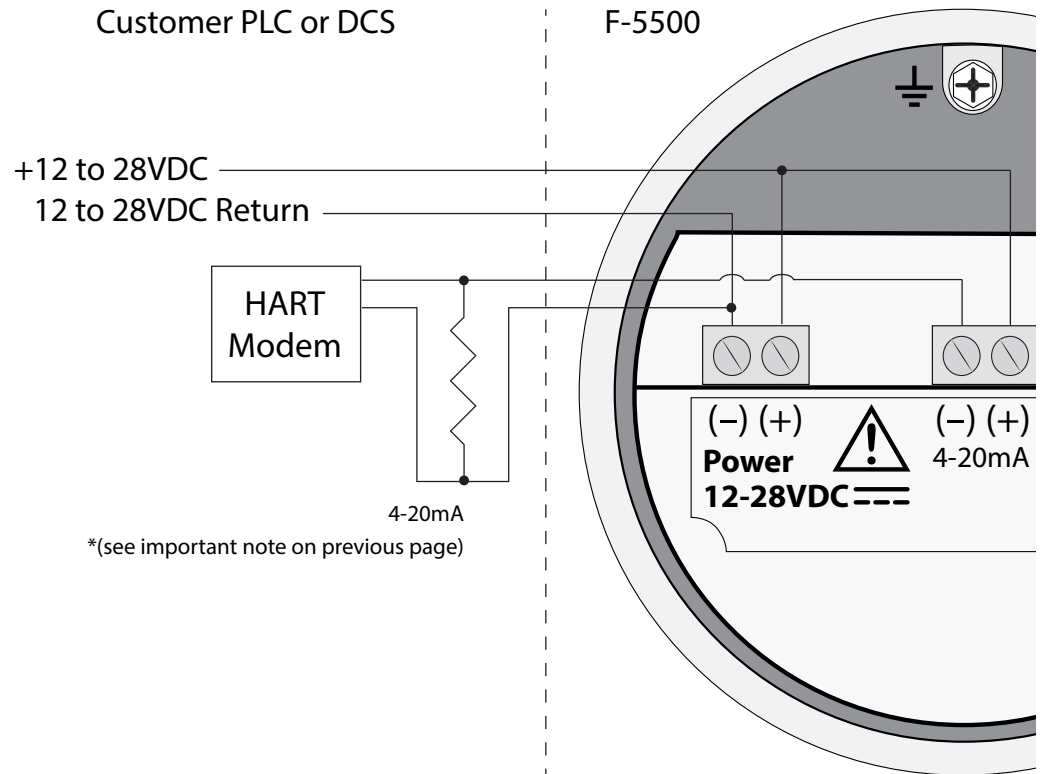

WIRING

Operation: Start Up

Start Up Sequence

Start Up Sequence

The meter automatically enters the Run/Measure mode after power up. The screen will show the software version of the F-5500 during power up.

USB Interface

USB Interface

The mini USB interface is a standard feature which allows communication with a PC to monitor readings and configure settings. F-5000 View, is a free application program from ONICON that connects to the USB interface and allows data monitoring, configuration setting, data logging to Excel, and an option to save and recall F-5500 configuration data.

F-5500 Display

F-5500 Display and User Interface

The F-5500 has a 2 line x 16 character display with 4 mechanical buttons. The meter can be programmed by using the display and User Interface. The User Interface can be accessed by removing the F-5500 cap. Be sure to replace the cap after you are done configuring the F-5500.

Fig. 4.1: F-5500 Display and User Interface

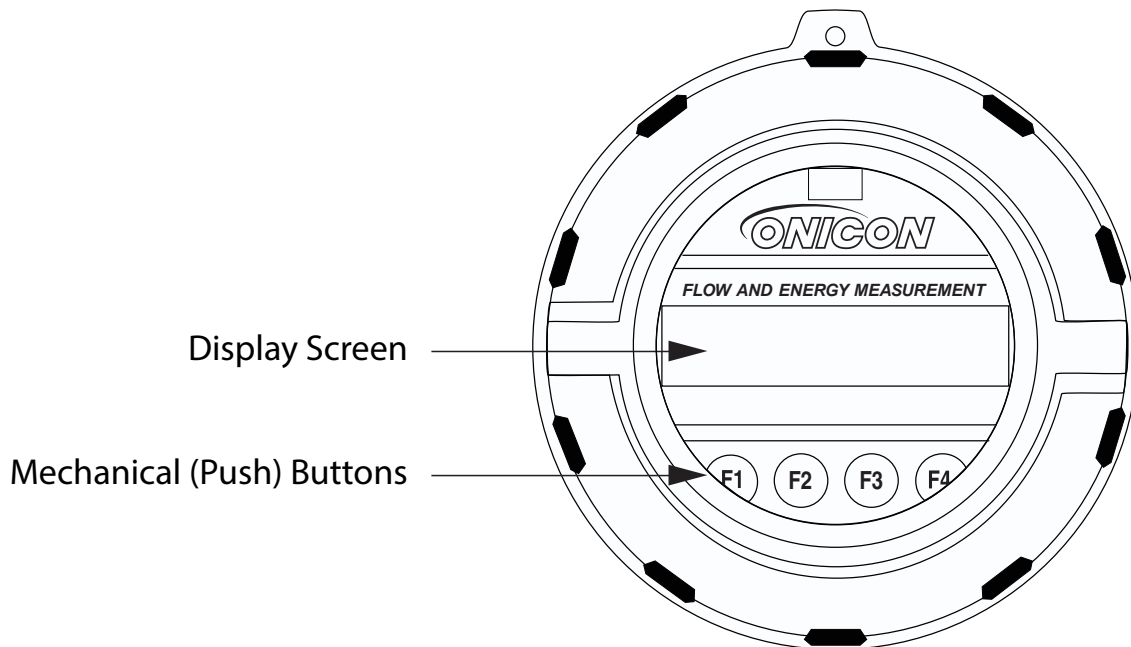

Operation: Display Screens

Display Screens

Measurement Mode Display Screens

In the measurement mode, there are four different display screens (display 1, 2, 3 and a prompt screen to enter the programming mode). Two display screens are user programmable (refer to Display Setup p. 46). Scrolling through the display is accomplished by pressing the F1 or F2 key to view the next or previous screen.

Engineering Menu Screens

Pressing the F1 and F2 keys at the same time enters the Engineering Menu screens (display 10 through 26). Key F4 is used to exit to Display screen #1.

Reset Total Screen

Pressing the F3 and F4 keys at the same time brings up the Reset Total screen (see p. 56) prompt.

Fig. 4.2: F-5500 Measurement Mode Display Screen Navigation

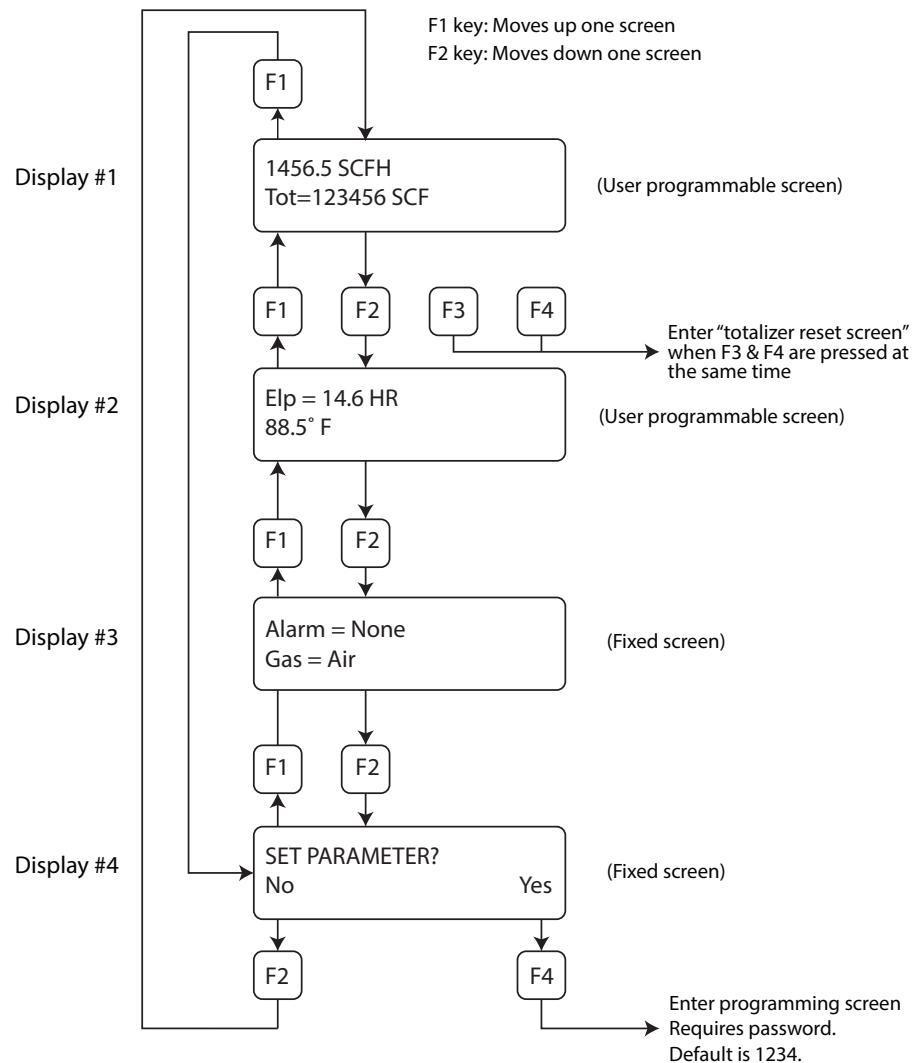

Operation: Programming

Programming by Display

Data Entry using the Display and User Interface

There are 2 basic types of menu entries: one for changing value or string and one for selecting from a selection list.

Value or String

To Change a Value or String :

VALUE = 0.91234
CHG OK

F1 F2 F3 F4

Press **CHG (F1)** key to change the value, **OK (F4)** to accept the value.

VALUE = 0.91234
UP DN NXT OK

F1 F2 F3 F4

Press the **UP (F1)** or **DN (F2)** key to select a new digit or character, the cursor points to the selected digit. Press **NXT (F3)** to select the next digit and **OK (F4)** to accept the entry.

Selecting from a List To Select from a List:

FLO UNT = SCFM
NXT OK

F1 F2 F3 F4

Press **NXT (F1)** key repeatedly until the correct selection is made and **OK (F4)** key to accept the entry.

Enter Programming Mode

Entering the Programming Mode

To enter the programming mode and access the Main Menu, press the **F1** or **F2** key in the normal running mode until the following screen is shown:

SET PARAMETERS ?
No Yes

F1 F2 F3 F4

Press **YES (F4)** and the following screen will prompt user to enter password:

PASWD: _
UP DN NXT OK

F1 F2 F3 F4

Operation: Programming

Programming by Display

Enter the correct password, then follow the instructions for changing a value as specified on page p. 41. The default Level 1 password is "1234".

If the wrong password is entered, the message "Wrong Password" will display and then return to the programming entry screen.

Main Menu

Main Menu

If the password is accepted, the Main Menu screen will be shown:

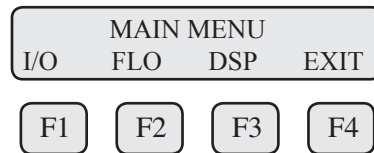

This is the Main Menu screen for the programming mode.

Press **EXIT (F4)** repeatedly until "Normal Mode" is seen briefly to exit the programming mode.

Analog 4-20mA Output

Analog 4-20mA Output

The following menu allows the scaling of the analog 4-20mA output.

From the Main Menu, press **I/O (F1)** to move to the 4-20mA output selection.

In this screen press **420 (F3)** (screen appearance may vary according to options).

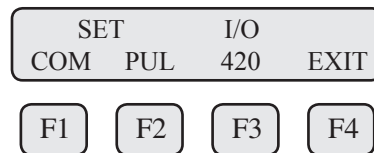

The 4-20mA output is programmable for flow or temperature:

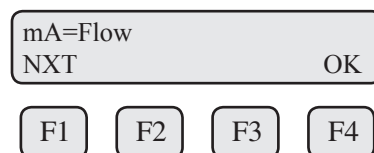

Selections for the 4-20mA output are:

Flow
Temp

Select **NXT (F1)** to select Flow or Temperature and then press **OK (F4)**.

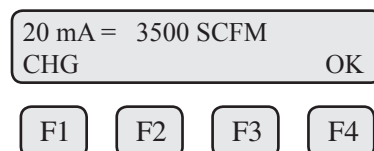

Operation: Programming

Programming by Display

Enter the value for the 20mA and press **OK (F4)** key to accept the setting.

Then the following screen will display:

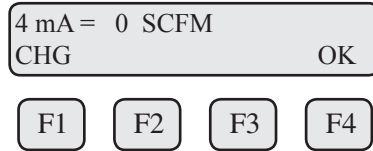

Enter the value for the 4mA and press **OK (F4)**.

NOTE: 4mA is normally set to 0.

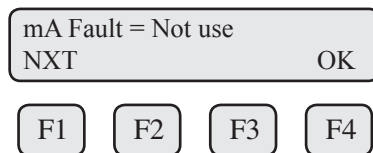

This menu allows the user to select an alarm fault level on the 4-20mA output. The alarm is activated when a serious issue is detected preventing the calculation of the correct flow rate. The 3.6mA and 21mA alarm outputs are related to the NAMUR alarm feature.

The options are:

- mA Fault=3.6 mA (Force the 4-20mA signal to 3.6mA on alarm)
- mA Fault=21 mA (Force the 4-20mA signal to 21mA on alarm)
- mA Fault=Not use (4-20mA signal alarm fault not used)

From any screen, press **(F4)** repeatedly until "Normal Mode" is seen briefly to exit the programming mode.

NOTE: When the flow rate exceeds the programmed value for the 20mA set point, the analog output will stay at 20mA and an alarm code will be generated.



Pulse/alarm Output

Pulse/alarm Output

If the Pulse/alarm feature was purchased as the second output for the Model F-5500, it can be accessed from the main menu, press **I/O (F1)** (screen appearance may vary).

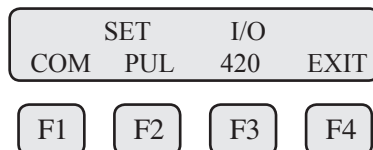

Press **PUL (F2)** to select the pulse output. The following screen will show:

Operation: Programming

Programming
by Display

OUT = Pulse	OK
NXT	

F1	F2	F3	F4
----	----	----	----

Press **NEXT (F1)** to cycle through output options until you have the selection for "OUT=Pulse" and press **OK (F4)**.

The pulse output scaling can be configured by specifying how many flow units total per pulse, U/P (e.g., 10 SCF per pulse). The pulse output provides a 500 millisecond pulse when the specified flow total is measured. The maximum frequency of the pulse output is 1 Hz.

PULSE OUTPUT		
U/P	FEQ	EXIT

F1	F2	F3	F4
----	----	----	----

Use **U/P (F2)** for unit per pulse scaling of the pulse alarm output. Use **FEQ (F3)** to view the maximum pulse output frequency and calculated maximum flow rate.

NOTE: When data pulse scaling is entered, the maximum flow rate will be re-calculated according to the settings.



**Unit per Pulse
(Pulse Scaling)**

Entering Data in Unit per Pulse:

From the Pulse/Alarm Output Menu, press **U/P (F2)** and the following screen will show:

UNT/PLS = 10	OK
CHG	

F1	F2	F3	F4
----	----	----	----

Press **CHG (F1)** to change the setting and then **OK (F4)** to accept entry.

The scaling value entered is in units per pulse (i.e. 10 flow units total per pulse).

The pulse scaling can be set to 1, 10, 100 or 1000 units per pulse. The pulse output provides a 500 millisecond pulse when the specified flow total is measured. The maximum frequency setting of the pulse output is 1 Hz.

**Max Flow and
Frequency**

Viewing the Maximum Frequency and Flow Rate:

From the Pulse/Alarm Output Menu on p. 45, press **FEQ (F3)** and the following screen will show:

MaxFreq=1 Hz	OK
--------------	----

F1	F2	F3	F4
----	----	----	----

Maximum pulse rate (frequency) is set to 1 Hz.

Operation: Programming

Programming by Display

View the maximum pulse rate (frequency) and press **OK (F4)**.
The next screen will show:

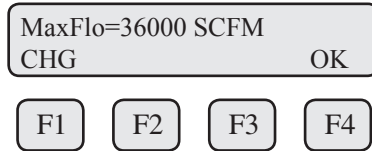

NOTE: If the measured flow rate exceeds the maximum pulse rate (frequency), the pulse output will stay at 1 Hz and the F-5500 will issue an alarm code.



Alarm Output

Alarm Output

If the Pulse/alarm feature was purchased as the second output for the Model F-5500, press **I/O (F1)** key from the Main Menu screen.

The screen will show:

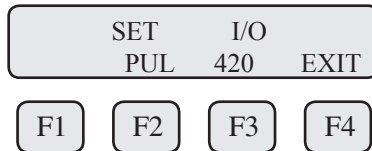

Then press **PUL (F2)** and the screen may show:



Then press **NXT (F1)** to select the correct alarm and press **OK (F4)**.

Selections are:

- Not used
- Pulse
- HiFloAlm = High Flow Alarm
- LoFloAlm = Low Flow Alarm
- HiTempAlm = High Temperature Alarm
- LoTempAlm = Low Temperature Alarm

When the output is set to Alarm and there is no alarm condition, the output will be on (0 volts). When an alarm is active, the output is turned off (12 to 24 volts).

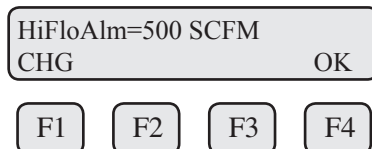

Enter the value for the limit by pressing **CHG (F1)** and then **OK (F4)**.

Operation: Programming



Serial Communication

NOTE: There is only one output to operate as a pulse output or an alarm output. Both cannot operate at the same time.

Serial Communication Settings

If RS485 Communication feature was purchased as the second output for the Model F-5500, the Serial communication settings can be programmed by pressing **I/O (F1)** key from the Main Menu. The screen will show:

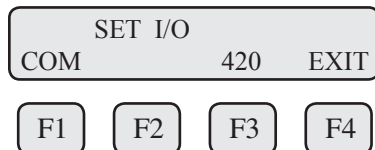

Press **COM (F1)** to select serial communication. The screen may show:

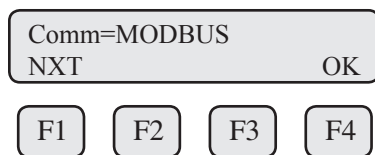

Options for serial communication are:

- NONE
- MODBUS
- BACnet
- HART



Display Setup

NOTE: Any selection other than "NONE" requires the communication option for the selected communication type. If enabling a communication option, see the Communications Protocols section of this manual.

Display Setup

Remember, there are four display screens that you can cycle through in normal operating mode (see "Fig. 4.2: F-5500 Measurement Mode Display Screen Navigation" on page 40). Two of the four display screens are fixed and cannot be changed (displays #3 & 4). The other two screens are programmable to show the information that you prefer and is discussed in this section.

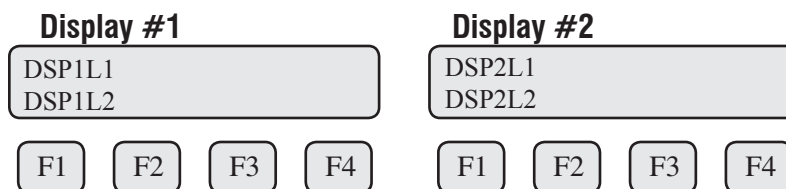

Operation: Programming

Programming
by Display

Selections are:

DSP1L1	Display 1, Line 1
DSP1L2	Display 1, Line 2
DSP2L1	Display 2, Line 1
DSP2L2	Display 2, Line 2

Programming Display Screens #1 & 2

To Program Display Screens #1 & 2:

From the Main Menu press **DSP (F3)** to select the display menu:

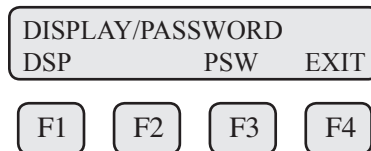

Press **DSP (F1)** key. The display will show:

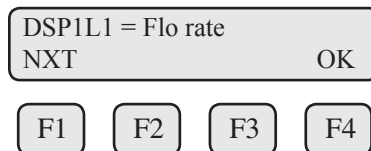

These are the selections for the display #1 line #1.

Selections are:

Flo rate	Flow rate
Total	Total mass or volume
Elps	Elapsed time
Temp	Temperature
Alarm	Error codes

When the selection is correct, press **OK (F4)** to accept. The display will then go through the same process for all 4 lines of the 2 programmable displays (DSP1L1, DSP1L2, DSP2L1 and DSP2L2).

After the last line of display 2 is accepted, the display will show the following menu:

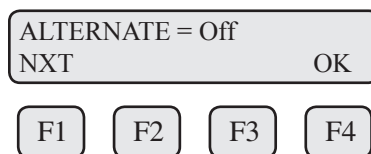

This menu allows you to alternate between menu display 1 and 2 every few seconds.

Selections are: On or Off

Press **OK (F4)** to accept selection. Press **EXIT (F4)** repeatedly until "Normal Mode" is seen briefly to exit the programming mode.

Operation: Programming

Password

Password

There are two user level passwords, only **Level 1** is programmable and gives access to all the normal settings. The second password is used to allow access to calibration factors and should normally never be changed unless advised by the ONICON service department, or to set a new password in the event that the user forgets the **Level 1** password.

Default **Level 1** password is “1234”, and **Level 2** password is “9111”. The **Level 1** programmable password can be disabled by setting it to “0”.

From the Main Menu press **DSP (F3)** to select the display menu:

Programming Password

To Program the Password:

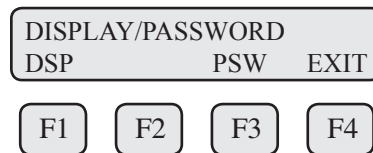

Press **PSW (F3)** key to select password.

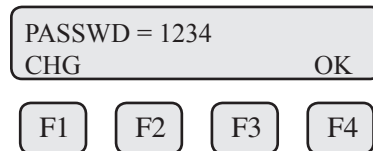

This screen displays the current **Level 1** password.

Press **CHG (F1)** key to change the password and enter new value.

Press **OK (F4)** to accept new data and exit programming by pressing **EXIT (F4)** key repeatedly until out of the programming mode.

NOTE: Password can be number or letter characters up to 4 digits.



Units Settings

Units Settings Menu

This menu is used to set the units for flow, temperature, and pressure. Reference temperature and reference pressure settings can be accessed also.

These values will be set at ONICON using information supplied by the customer. These values can be changed to match a new application. The units settings are accessed from the Main Menu.

To access the Unit Settings Menu:

Operation: Programming

Programming
by Display

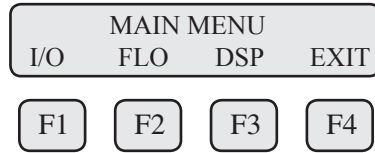

Press **FLO (F2)**:

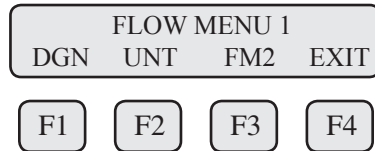

Flow Units

Press **UNT (F2)** for Unit selection.

The screen will show:

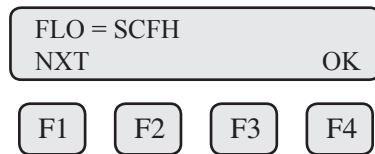

Press **NXT (F1)** to change selection and **OK (F4)** to accept.



NOTE: The totalizer (total flow measured) will roll over when reaching a certain value. The maximum value is dependent on the flow units selected (see Totalizer Rollover p. 56).

Selections for flow units are:

SCFM	LBS/M	MSCFD (MCFD)
SCFH	LBS/S	SM3/H
NM3/H	NLPH	MT/H
NM3/M	NLPM	NM3/D
KG/H	MMSCFD (MMCFD)	MMSCFM
KG/M	LBS/D	SCFD
KG/S	SLPM	MCFD (MSCFD)
LBS/H	NLPS	SM3/M
		SM3/D



WARNING!

The F-5500 re-calculates area, 4 and 20mA values, maximum flow for the pulse output and zero flow cutoff when changing flow units.



NOTE: The totalizer values do not adjust or correct for the new units. When changing flow units, log the totals in the totalizer and then reset the totalizer after they've changed flow units to maintain accuracy in the totalizer.

Operation: Programming

Temperature Units

After pressing **OK (F4)** to accept the Flow unit the display will prompt for the temperature unit setting:

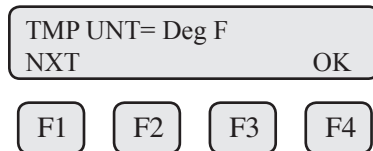

Press **NXT (F1)** to change selection and **OK (F4)** to accept.

Selections for Temperature units are:

- Deg C
- Deg F

Reference Temperature

After pressing **OK (F4)** to accept the temperature unit setting, the display will prompt for temperature reference in selected unit.

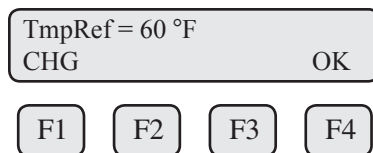

Press **CHG (F1)** to change the reference and **OK (F4)** to accept.

Pressure Units

After pressing **OK (F4)** to accept the reference temperature, the display will prompt for the reference pressure unit selection:

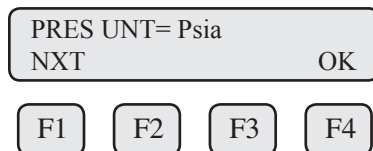

Press **NXT (F1)** to select next entry and **OK (F4)** to accept.

Selections are:

- mmHG Millimeters of mercury (absolute)
- Psia Pounds per square inch absolute
- bara Bar absolute

Reference Pressure

After the pressure unit selection is made, the display will show a menu to enter the reference pressure:

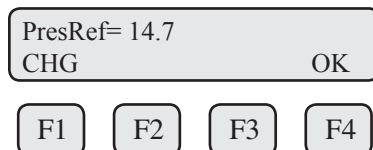

Operation: Programming

Programming by Display Density

Press **CHG (F1)** to change it and **OK (F4)** to accept.

After the reference pressure is accepted, the F-5500 will recalculate and display gas density at user's reference temperature and pressure:

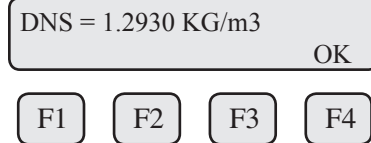

The gas density is for information only. Press **OK (F4)** to continue.

Flow Parameters

Flow Parameters

This is the menu used to set various flow parameter values. They are: Flow cutoff, pipe diameter, filter, high and low alarm for flow and temperature.

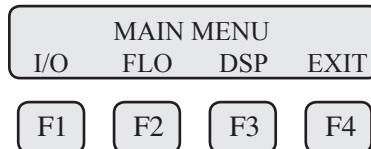

The menu is accessed from the Main Menu by pressing **FLO (F2)**:

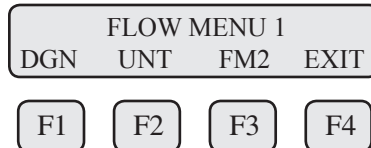

Then press **FM2 (F3)**:

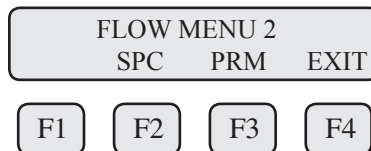

NOTE: The **SPC** function key will only appear and be accessible from a **Level 2** password.

Then press **PRM (F3)**.

Flow Cutoff

The first parameter is **Flow Cutoff**:

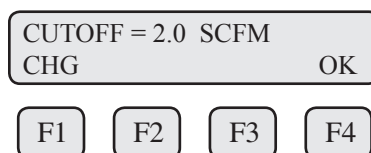

Operation: Programming

Programming by Display

Enter the value for the low flow cutoff and then press **OK (F4)**.
When the flow rate falls below the zero flow cutoff, the flow meter will display a flow value of zero.

Pipe Diameter

To set the **Pipe Diameter**

Pipe_id = 3.068 In
CHG OK

F1 F2 F3 F4

Enter the pipe diameter in inches or **millimeters** and then press **OK (F4)**.
Use millimeters for metric flow unit selections and inches for English flow unit selections. If the pipe/duct is a square or rectangle, the hydraulic diameter (equivalent value for a round pipe) must be entered for the pipe ID.

Filter Value

The **Filter Value** is entered in seconds. The allowable time constant range is 0.8 to 10 seconds. The filter time interval is proportional to the dampening.

Enter the filter value and then press **OK (F4)**.

FILTER = 0.8 sec
CHG OK

F1 F2 F3 F4

High Flow Rate Alarm

To set the parameters for a **High Flow Rate Alarm**:

HiFloAlm = 1234 SCFM
CHG OK

F1 F2 F3 F4

This is the upper flow limit alarm value that can be associated with the alarm output. An alarm code is generated when the flow value exceeds this limit. If no checking is needed, this value should be set to zero.

Press **OK (F4)** to accept the value.

Low Flow Rate Alarm

To set the parameters for a **Low Flow Rate Alarm**:

LoFloAlm = 100 SCFM
CHG OK

F1 F2 F3 F4

Operation: Programming

Programming by Display

This is the lower flow limit alarm value that can be associated with the alarm output. An alarm code is generated when the flow value is below this limit. If no checking is needed, this value should be set to zero.

Press **OK (F4)** to accept the value.

High Temp Alarm

To set the parameters for a **High Temperature Alarm**:

HiTmpAlm = 200 F	
CHG	OK

F1 F2 F3 F4

This is the upper temperature limit alarm value that can be associated with the alarm output. An alarm code is generated when the temperature value exceeds this limit. If no checking is needed, this value should be set to zero.

Press **OK (F4)** to accept the value.

Low Temp Alarm

To set the parameters for a **Low Temperature Alarm**:

LoTmpAlm = 20 F	
CHG	OK

F1 F2 F3 F4

This is the lower temperature limit alarm value that can be associated with the alarm output. An alarm code is generated when the temperature value is below this limit. If no checking is needed, this value should be set to zero.

Press **OK (F4)** to accept the value.



NOTE: If the programming menu was entered with a **Level 2** password, then more menus will be shown concerning factory-set parameters that should not be changed.

Operation: Programming

K Factor

K Factor

The K FACTOR allows the user to adjust the meter's calibration. The ONICON flow meter increases the calculated flow rate by the K Factor. This results in a direct scaling of the meter's output across the entire full range.

The K Factor parameter is accessed from the "Flow Menu 2" menu by entering a **Level 2** password "9111" and pressing the **SPC** key (**F2**).

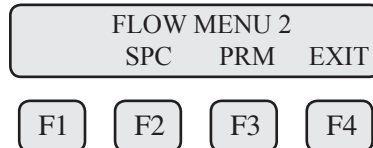

The following screen will be displayed:

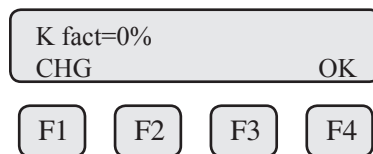

Press **CHG (F1)**. Add the correction factor and press OK (**F4**).

For Example:

If you want the flow meter to read 5% higher, enter 5.0%.

If you want the flow meter to read 5% lower, enter -5.0%.

If an existing K Factor is present, add the additional K Factor to the existing value.

Upon pressing **OK (F4)**, an option to restore the database will follow.

Restore Database

Restore Database

In case of user error, the ability to restore the meter to the original factory settings can be achieved in this menu. The display will show:

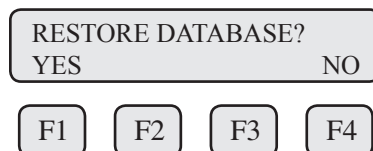

Press **YES (F1)** ONLY if you want to restore your database to the initial factory setting that the meter was shipped with. All current user-entered settings will be overwritten.

The green LP3 LED will flash at a faster pace until the recall is performed. The "RESET CRC" screen will follow "RESTORE DATABASE".

Upon pressing **OK (F4)**, an option to reset the NVRAM CRC will follow.

Operation: Programming

Reset CRC

Reset CRC

If the NVRAM CRC check fails (Error Code 36), the programmed settings values will need to be verified and corrected before clearing the error. Call ONICON Customer Service if you need assistance.

RESET CRC?	
YES	NO
F1	F2
F3	F4

Press **YES (F1) ONLY** if you want to reset the CRC and generate a new CRC value.

Non-Resetable Totalizer

Non-Resetable Totalizer Activation

Regulations in some geographic locations require that flow totalizers be non-resetable. The F-5500 can conform to these regulations.



WARNING! Once the non-resetable totalizer (NRT) has been activated on an F-5500 flow meter, the change cannot be undone. The non-resetable totalizer is only recommended for applications that require it.

After it has been enabled, your F-5500's totalizer and elapsed time counters will be non-resetable.

SET NRT?	
YES	NO
F1	F2
F3	F4

Press **YES (F1) ONLY** if you want to set the NRT.

ARE YOU SURE?	
YES	NO
F1	F2
F3	F4

If you are certain you want to activate the Non-resetable totalizer, select **YES (F1)**.

Operation: Programming

Reset Total

Reset Total and Elapsed Time

Enter the flow totalizer and elapsed time screen by pressing the **F3** and **F4** keys at the same time in the normal running mode (password required).

RESET TOTAL ?			
NO			YES

F1	F2	F3	F4
----	----	----	----

Press **YES (F4)** to reset total and elapsed time. Press **NO (F1)** to cancel.

NOTE: This feature is not available on non-resettable units.



Totalizer Rollover

Totalizer Rollover: The F-5500 has an automatic roll-over function. The total flow count of the F-5500 will roll over after the following values:

Most flow units:	99,999,999,999
MSCFD:	999,999,999
MMSCFM:	9,999,999
MMSCFD:	999,999

Simulation

Simulation

This menu allows for simulation of flow rate and temperature. It should only be used for testing and demonstration purposes. **Make sure to return all of these simulation values to zero, before returning to the normal mode of operation.**

CAUTION! If the 4-20mA and/or the pulse/alarm outputs are connected to controllers, set the controllers to “manual”. This will ensure that the simulated signals do not cause false controller action.



The menu is accessible from the main programming menu by pressing **FLO**, and **DGN (F1)**:

FLOW MENU 1			
DGN	UNT	FM2	EXIT

F1	F2	F3	F4
----	----	----	----

Pressing **DGN (F1)** will show:

DIAGNOSTIC		
SIM	ZERO	EXIT

F1	F2	F3	F4
----	----	----	----

Operation: Programming

Pressing **SIM (F1)** will show:

Simulate Flow?	
YES	NO
F1	F2
F3	F4

Press **YES (F1)** to continue.

FloSim = 0 SCFH	
CHG	OK
F1	F2
F3	F4

Enter the value and then press **OK (F4)**.

NOTE: Enter zero to disable this feature.

Simulate Temp?	
YES	NO
F1	F2
F3	F4

Press **YES (F1)** to continue.

TmpSim = 0 ° F	
CHG	OK
F1	F2
F3	F4

Enter the value and then press **OK (F4)**.

NOTE: Enter zero to disable this feature.

ENABLE SIM?	
YES	NO
F1	F2
F3	F4

Press **YES (F1)** to start the simulation mode, otherwise press **NO (F4)**. Upon pressing either key, the program will return to the FLOW MENU 1 screen.

NOTE: Simulation Mode will be cleared if the power is cycled.



Operation: Zero CAL-CHECK®

Calibration

Calibration of the ONICON Model F-5500 Thermal Flow Meter

To ensure that all ONICON flow meters meet specified performance parameters and provide accurate, repeatable measurements in the field, all calibrations are performed with NIST-traceable flow standards. Each meter is shipped from the factory with a ONICON Calibration Certificate.

Calibration Validation

Calibration Validation

Calibration Validation allows our customers to validate the accuracy and functionality of the meter in the field with a push of a button. By performing a simple test, the operator can verify that the meter is running accurately.

Zero CAL-CHECK® ensures the repeatability, functionality of the sensor and its associated signal processing circuitry, and cleanliness of the sensor.

ONICON has developed the Zero CAL-CHECK® Calibration Validation to help our customers avoid sending the meter back for annual or biennial re-calibrations.

Zero CAL-CHECK Test

Zero CAL-CHECK® Calibration Validation Test

The Zero CAL-CHECK® test is used to ensure that the flow meter still retains its original NIST-traceable calibration at zero flow. If zero flow can be established, the sensor does not need to be removed and the procedure can be done in the pipe. Alternatively, a clean, dry bottle can be used to create a “no flow” condition out of the pipe.



NOTE: If the Zero CAL-CHECK® test is performed using the ONICON F-5000 View Software, at the completion of the test, a Zero CAL-CHECK® Certificate may be printed for a record of the test. This certificate will display a pass/fail result.

Achieving Zero Flow - In-Situ (In the Pipe)

Techniques for Achieving Zero Flow - In the Pipe

In-situ (in the pipe) Zero CAL-CHECK® testing can be achieved by a pipe bypass (valving-off). If space allows, redirect the flow through a bypass pipe section or valve off the meter in order to isolate the meter's sensor in the place where it has been installed. While the flow is redirected, the Zero CAL-CHECK® test can be performed. Once the test is complete, the valves to the bypass may be closed and flow may be directed back to the meter's sensor where flow monitoring can continue as normal.

Operation: Zero CAL-CHECK®

Zero CAL-CHECK®

Fig. 4.3: Normal Mode vs. Zero CAL-CHECK® Mode

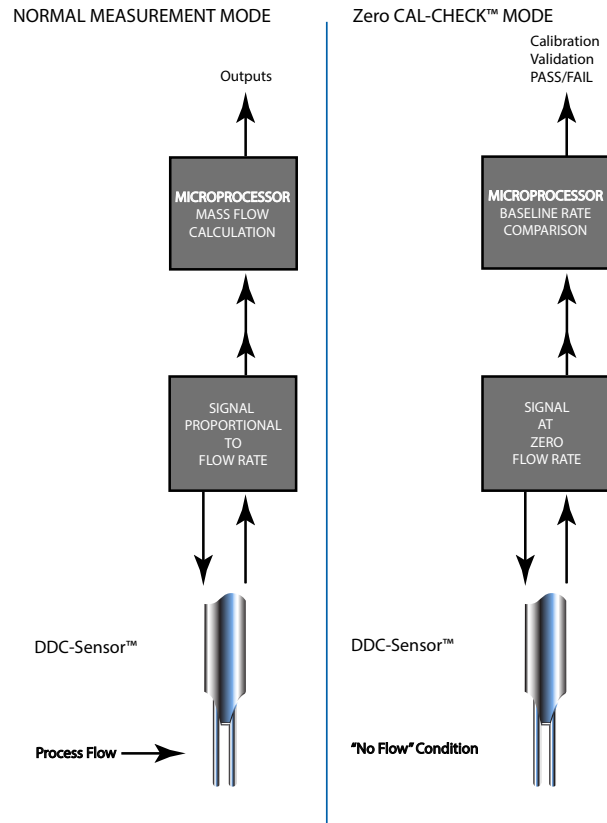

Achieving Zero Flow - Out of Pipe

Achieving Zero Flow - Out of Pipe

If space limitations prevent in-situ testing at zero flow as listed above, then Out of Pipe testing must be performed.

With this configuration, the meter must be removed from the process, the test performed, and then the meter returned to the process after testing has been completed.

Due to the high sensitivity of the DDC-Sensor™, it is necessary to isolate the sensor once the meter has been removed from the pipe. This can be achieved with a closed container in order to isolate the sensor and achieve the "no flow" condition necessary to perform the Zero CAL-CHECK® test. If the Zero CAL-CHECK® test is to be performed out of the pipe, the meter must be set upside-down (probe pointing up) and a clean dry plastic bottle placed back over the sensor to achieve the factory baseline that the meter has been set with.

Operation: Zero CAL-CHECK®

Performing
Zero CAL-
CHECK® Test

Performing the Zero CAL-CHECK® Calibration Validation Test

The Zero CAL-CHECK® test must be performed at zero flow to ensure a valid test result. This test is used to confirm that the flow meter still retains its original NIST-traceable calibration at zero flow and that the sensor is free of film or residue that may affect readings. The test takes less than 5 minutes to complete. At the conclusion of the test, a Pass or Fail message will be displayed. Press **F4** at the conclusion of the test to return to normal measuring mode or to terminate the test.

Press **FLO (F2)** from the main menu. The display will show:

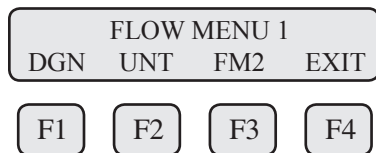

Press **DGN (F1)**. The display will show:

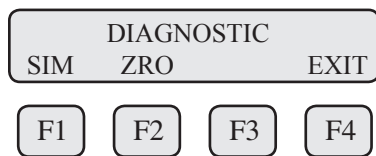

Press **ZRO (F2)**. The display will show:

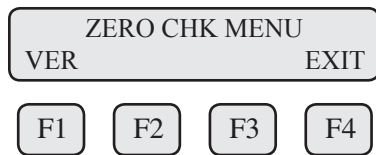

Press **VER (F1)** key to continue.

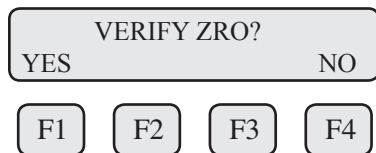

Press **YES (F1)** key to continue.



NOTE: For accurate readings and best test results, perform a visual inspection of sensor window for damage/deformity and condition of sensor elements before starting the test.

Operation: Zero CAL-CHECK®

Performing
Zero CAL-
CHECK® Test

Process Zero and Stable? YES EXIT

F1
F2
F3
F4



WARNING! You must ensure that there is a no flow condition before proceeding. If you are performing the test in a bottle, be sure to isolate the sensor in a closed container - any air movement (even from a fan) may result in a false "fail" result.

Once process is stable, press **YES (F3)** key to begin the Zero CAL-CHECK®.

Verifying ZRO T=xx
y.yyy

F1
F2
F3
F4

This test will take less than 5 minutes. The T=xx is a count down timer indicating how much time is left to finish the test.

ZRO=2.321
Fail OK

F1
F2
F3
F4

OR

ZRO=0.911
Warning OK

F1
F2
F3
F4

OR

ZRO=0.259
Pass OK

F1
F2
F3
F4

Upon test completion, the final value will be displayed along with the test result. The test result may be:

- Pass < 0.80
- Warning > 0.80 < 1.0
- Fail > 1.0

If a "Warning" or "Fail" result is displayed, ONICON recommends that the probe be removed from the pipe, the sensor cleaned, and the test be performed again. If the test was performed in the pipe the first time, perform the test in a bottle for the re-test.

If a "Warning" or "Fail" result is displayed after performing the test a second time, please call ONICON Service at 727-447-6140 for assistance.

OPERATION

Modbus Introduction

Modbus Introduction

Scope

This portion of the manual describes the Modbus implementation using RS485 serial communication physical layer for the ONICON F-5500 Mass flow meter based on the Modicon Modbus Protocol (PI-MBUS-300 Rev. J).

Modbus Protocol

Modbus Protocol

MODBUS Protocol is an application layer messaging protocol that provides client/server communications between devices. MODBUS is a request/reply protocol and offers services specified by function codes.

The size of the MODBUS Protocol Data Unit is limited by the size constraint inherited from the first MODBUS implementation on Serial Line network (max. RS485 Application Data Unit = 256 bytes).

Therefore, MODBUS PDU for serial line communication = 256 – Server address (1 byte) – CRC (2 bytes) = 253 bytes.

RS485 ADU = 253 + Server address (1 byte) + CRC (2 bytes) = 256 bytes.

For more information on MODBUS go to the web site <http://www.modbus.org/>.

Command Request:

<Meter Address> <Function code> <Register start address high> <Register start address low> <Register count high> <Register count low> <CRC high> <CRC low>

Command Response:

<Meter Address> <Function code> <Data byte count> <Data register high> <Data register low> ... <Data register high> <Data register low> <CRC high> <CRC low>

NOTE: The data shown in brackets < > represents one byte of data.



Modbus Indicators

Modbus Indicators

LED indicator LP3 cycles on and off to indicate that the F-5500 is operating. LED indicator LP2 blinks when Modbus signals are received and LP1 blinks when Modbus signals are transmitted.

F-5500 Commands Supported

F-5500 Commands Supported

The F-5500 supports the following commands:

- 1) Command 03: Read holding registers
- 2) Command 04: Read input register.
- 3) Command 06: Preset single register

F-5500 Commands Supported by Modbus

Read Holding Registers

Read Holding Registers (command 03)

This command reads the basic variable from the F-5500 and has the following format:

Request:

<Meter Address> <Command code=03> <Register start address high>
 <Register start address low> <Register count high> <Register count low>
 <CRC high> <CRC low>

Response:

<Meter Address> <Command code=03> <Byte count> <Data high> <Data low> ... <Data high> <Data low> <CRC high> <CRC low>

Example:

Request data register at starting address 0x0000 and specifying only 1 register

<0x01> <0x03> <0x00> <0x00> <0x00> <0x01> <0x0a> <0x84>

Response:

<0x01> <0x03> <0x02> <xx> <xx> <CRC high> <CRC low>

Where xx xx is the data register value.

Table 5.1: F-5500 Modbus Holding Registers

Register Address	Modbus Address	Data Type	Scaling	Comment
0x00	40001	Flow in Eng units (long integer, lower 16 bits)	No	Mass flow in selected units
0x01	40002	Flow in Eng units (long integer, upper 16 bits)	No	
0x02	40003	Total (long integer, lower 16 bits)	No	Total in selected units
0x03	40004	Total (long integer, upper 16 bits)	No	
0x04	40005	Temperature (long integer, lower 16 bits)	*10	Temperature in selected units * 10
0x05	40006	Temperature (long integer, upper 16 bits)	*10	
0x06	40007	Elapsed time (long integer, lower 16 bits)	*10	Elapsed time in hours * 10
0x07	40008	Elapsed time (long integer, upper 16 bits)	*10	
0x08	40009	Spare/not used		
0x09	40010	Spare/not used		
0x0A	40011	Flow in Eng units * 10	10	Mass flow in selected units * 10
0x0B	40012	Flow in Eng units *100	100	Mass flow in selected units * 100
0x0C	40013	Total *100	100	Total in selected units * 100
0x0D	40014	Spare/ Not used		
0x0E	40015	Spare/ Not used		
0x0F	40016	Status	No	Status

F-5500 Commands Supported by Modbus

Register Address	Modbus Address	Data Type	Scaling	Comment
0x10	40017	Status 2	No	
0x11	40018	Control Register (Write Only)	No	Control Register
0x12	40019	Spare/ Not used		
0x13	40020	Flow in Eng units (float, upper 16 bits)	No	Mass flow in selected units
0x14	40021	Flow in Eng units (float, lower 16 bits)	No	Mass flow in selected units
0x15	40022	Total in Eng units (float, upper 16 bits)	No	Total in selected units
0x16	40023	Total in Eng units (float, lower 16 bits)	No	Total in selected units
0x17	40024	Spare/ Not used		
0x18	40025	Spare/ Not used		
0x19	40026	Temperature in selected units (float, upper 16 bits)	No	Temperature in selected units
0x1A	40027	Temperature in selected units (float, lower 16 bits)	No	Temperature in selected units
0x1B	40028	Elapsed time in hours (float, upper 16 bits)	No	Elapsed time in hours
0x1C	40029	Elapsed time in hours (float, lower 16 bits)	No	Elapsed time in hours
0x1D	40030	Zero CAL-CHECK (float, upper 16 bits)	No	
0x1E	40031	Zero CAL-CHECK (float, lower 16 bits)	No	
0x1F	40032	Spare/ Not used		
0x20	40033	Spare/ Not used		
0x21	40034	Spare/ Not used		
0x22	40035	Spare/ Not used		
0x23	40036	Spare/ Not used		



Read Input Register

NOTE: Registers A, B & C are provided to get more resolution for low flow and total. When value exceeds the 16 bit registers, they will be frozen with all 16 bits set.

Read Input Register (F-5500 Status, Command 04)

This command is used to report the F-5500 status information.

Request:

<Meter Address> <Command code=04> <Register address =0> <Register address =0> <Register count =0> <Register count =1> <CRC high> <CRC low>

Response:

<Meter Address> <Command code=04> <Byte count =2> <Status High> <Status Low> <CRC high> <CRC low>

F-5500 Commands Supported by Modbus

Table 5.2: Status Bits Definitions for Command 04, Modbus Address 30001

Bit	Definition	Comment
0	Power up indication	Cleared when out of the power up sequence
1	Flow rate reached high limit threshold	Set limit to zero to disable
2	Flow rate reached low limit threshold	Set limit to zero to disable
3	Temperature reached high limit threshold	Set limit to zero to disable
4	Temperature reached low limit threshold	Set limit to zero to disable
5	Sensor reading is out of range	Check sensor wiring
6	Gas mix error	Gas mix must total 100%
7	Incorrect Settings	Check settings
8	In simulation mode	Set simulation value to 0 to disable
9	Pulse/alarm output is out of range	Check pulse/alarm output settings
10	Analog 4-20 mA for flow/temp is out of range	Check analog output settings
11	Not used	Not used
12	Not used	Not used
13	Not used	Not used
14	CRC error	Check parameters and reset CRC
15	Error in Total	Reset total to clear alarm

Table 5.3: Status 2 Bits Definitions for Command 04, Modbus Address 30002

Bit	Definition	Comment
0	Pulse hardware detected	
1	Busy	Busy
2	Not used	Not used
3	Not used	Not used
4	Zero CAL-CHECK in process	
5	Zero CAL-CHECK fail	
6	Zero CAL-CHECK aborted	
7	Zero CAL-CHECK warning	

Preset Single Register

Preset Single Register (Command 06)

This command is used to perform miscellaneous functions such as clearing the totalizer and elapsed time. The register address is Modbus=40018 and the data to write is described below.

Request:

<Meter Address> <Command code=06> <Register address high=0x00>
 <Register address low=0x11> <Register data high=0x00> <Register data low
 =0x02> <CRC high> <CRC low>

Modbus Programming

Response:

<Meter Address> <Command code=06> <Register address =0x00>
 <Register address =0x11> <Register data=0x00> <Register data =0x02>
 <CRC high> <CRC low>

Reset Total:

Address = 40018, data = 0x02
 This command is used to clear the Totalizer and elapsed time registers

Programming

Enter the Programming Mode - RS485 Modbus RTU

Press the **F1** or the **F2** key repeatedly, in the normal running mode, until the following screen is shown. This enters the programming mode:

SET PARAMETERS?	
NO	YES

F1 F2 F3 F4

Press **YES (F4)** and then the following screen will prompt the user to enter the password if enabled:

PASWD: _			
UP	DN	NXT	OK

F1 F2 F3 F4

Enter the correct password. Default password for Level 1 is 1234.

Press the **UP (F1)** or **DN (F2)** key to select a new digit or character, the cursor points to the selected digit. Press **NXT (F3)** to select the next digit and **OK (F4)** to accept the entry.

If the wrong password is entered, the message "Wrong Password" will be displayed for a few seconds and then return to the programming entry screen. If the password is accepted, the following screen will be shown:

MAIN MENU			
I/O	FLO	DSP	EXIT

F1 F2 F3 F4

Modbus Programming

This is the Main Menu for the programming mode. To exit the programming mode, press **EXIT (F4)** repeatedly until "Normal Mode" is seen briefly.

Modbus Communication Parameters

Communication Protocol and Parameters

To program the communication parameters, start at the Main Menu:

MAIN MENU			
I/O	FLO	DSP	EXIT
F1	F2	F3	F4

Then press **I/O (F1)** to set Inputs/Outputs:

SET I/O			
COM	420	EXIT	
F1	F2	F3	F4

Then press **COM (F1)** to select communication parameters.

Set Bus protocol for Modbus:

Comm=MODBUS			
NXT	OK		
F1	F2	F3	F4

Press **NXT (F1)** repeatedly until Modbus is selected as shown and then press **OK (F4)** to accept the setting.

The following communication parameters are only available for MODBUS:

Baud=9600			
NXT	OK		
F1	F2	F3	F4

Press **NXT (F1)** repeatedly until the correct selection is shown and then press **OK (F4)** to accept the setting.

Modbus Programming

Modbus
Communication
Parameters

Selections are: "115200"
"57600"
"38400"
"19200"
"9600"
"4800"
"2400"
"1200"

Parity=EVEN
NXT OK

F1 F2 F3 F4

Press **NXT (F1)** repeatedly until the correct selection is shown and then press **OK (F4)** to accept the setting.

Selections are: "NONE"
"ODD"
"EVEN"

Address=02
CHG OK

F1 F2 F3 F4

Press **CHG (F1)** to change the address and then press **OK (F4)** to accept the setting.

Selections are between 01 and 247.

NOTE: Power cycle is required for the new settings to take effect.



BACnet Introduction

BACnet Introduction

Scope

This portion of the manual describes the BACnet MS/TP implementation using RS485 serial communication physical layer for the ONICON F-5500 Mass flow meter.

BACnet Protocol

BACnet Protocol

BACnet MS/TP (Building Automation and Control Network /Master Slave Token Passing) is a data link layer protocol designed for communication between devices in building automation control systems. The protocol is based on devices, objects, properties, and services. Information inside a BACnet device is organized into a series of objects. Properties allow the data from the object to be written or read. The actions that a BACnet device uses to interact with another device are the services.

The F-5500 Device profile: BACnet Smart Sensor (B-SS)

F-5500 supports the following device binding methods:

Receive Who-Is, send I-Am (BIBB DM-DDB-B)
Receive Who-Has, send I-Have (BIBB DM-DOB-B)

Objects for F-5500:

Analog Input 1 = Flow
Analog Input 2 = Gas Temperature
Analog Input 3 = Total Flow / Reset Total
Analog Input 4 = Elapsed Time since reset

BACnet Indicators

BACnet Indicators

LED indicator LP3 cycles on and off to indicate that the F-5500 is operating.
LED indicator LP2 blinks when BACnet signals are received and LP1 blinks when BACnet signals are transmitted.

BACnet Protocol

BACnet Protocol Device object property identifiers and restrictions: (properties that are writable)

Object _ Name	< 10 bytes
Object _ Identifier	Device Type only
Max _ info _ Frames	< =255
Max _ Master	< =127

BACnet Interoperability Building Blocks (BIBB'S) provide function capabilities for data exchange between devices.

F-5500 BIBB's supported:

- DS-RP-B Read Property
- DS-WP-B Write Property
- DM-DDB-B Dynamic Device Binding
- DM-DOB-B Dynamic Object Binding
- DM-DCC-B Device Communication Control
- DS-RPM-B ReadPropertyMultiple
- DM-RD-B Reinitialize Device

MS/TP baud rates:

9600, 19200, 38400, 57600, 76800, 115200

F-5500 Character sets supported:

ANSI X3.4, UTF-8

ONICON BACnet vendor ID: 206

For more information about BACnet visit <http://www.bacnet.org/>.

BACnet Programming

Enter the Programming Mode - BACnet MS/TP

Press the F1 or the F2 key repeatedly, in the normal running mode, until the following screen is shown. This enters the programming mode:

SET PARAMETERS?
NO YES

F1
F2
F3
F4

BACnet Programming

BACnet Programming

Press **YES (F4)** and then the following screen will prompt the user to enter the password if enabled:

PASWD: _			
UP	DN	NXT	OK

F1 F2 F3 F4

Enter the correct password. Default password for Level 1 is 1234.

BACnet Communication Parameters

Communication Protocol and Parameters

To program the communication parameters, press **I/O (F1)** key from the main menu.

MAIN MENU			
I/O	FLO	DSP	EXIT

F1 F2 F3 F4

This is the main menu for the programming mode. To exit the programming mode, press **EXIT (F4)** repeatedly until "Normal Mode" is seen briefly. Choose **I/O (F1)** to access the communication output.

SET I/O			
COM	420	EXIT	

F1 F2 F3 F4

Then press **COM (F1)** to select communication parameters

Set Bus protocol for BACnet:

Comm=BACnet			
NXT			OK

F1 F2 F3 F4

Press **NXT (F1)** until BACnet is selected as shown and then press **OK (F4)** to accept the setting.

Baud=9600			
NXT			OK

F1 F2 F3 F4

Press **NXT (F1)** repeatedly until the correct selection is shown and then press **OK (F4)** to accept the setting.

BACnet Programming

BACnet
Communication
Parameters

Selections are: "9600"
"19200"
"38400"
"57600"
"76800"
"115200"

Next select the MS/TP Mac address. The selection is from 0-127. Please note that only one device can be on a MS/TP Mac address.

MAC_ADD=23
CHG OK

F1 F2 F3 F4

Next select the MS/TP Max Master using **CHG (F1)**. The selection is from 0-127. Press **OK (F4)** to accept the setting.

MAX_MASTER=127
CHG OK

F1 F2 F3 F4

Next input the device object instance using **CHG (F1)**. Selection is from 0-4194303. Press **OK (F4)** to accept the setting.

ID=12531
CHG OK

F1 F2 F3 F4

Next enter the device object name (9 characters maximum) using **CHG (F1)**. Press **OK (F4)** to accept the setting.

NAME=F-5500_FLOW
CHG OK

F1 F2 F3 F4

NOTE: Power cycle is required for the new settings to take effect.



HART Introduction

HART Introduction

Scope

The ONICON' Model F-5500 transmitter complies with HART Protocol Revision 7.1. This section specifies all the device-specific features and documents HART Protocol implementation details (e.g., the Engineering Unit Codes supported). The functionality of this Field Device is described sufficiently to allow its proper application in a process and its complete support in HART-capable Host Applications.

Purpose

Purpose

This section provides a complete description of this Field Device from a HART Communication perspective.

The specification in this section is designed to be a technical reference for HART capable Host Application Developers, System Integrators and knowledgeable End Users. It also provides functional specifications (e.g., commands and performance requirements) used during development, maintenance and testing. The information given in this section assumes the reader is familiar with HART Protocol requirements and terminology.

References

References

HART Smart Communications Protocol Specification. HCF_SPEC-12. Available from the HCF.

Device Identification

Device Identification

Manufacturer Name:	<u>ONICON Inc</u>	Model Name(s):	<u>F-5500</u>
Manufacturer ID Code:	<u>0x60D4 hex</u>	Device Type Code:	<u>57583 (EOEF Hex)</u>
HART Protocol Revision	<u>7.1</u>	Device Revision:	<u>1</u>
Number of Device Variables	<u>None</u>		
Physical Layers Supported	<u>FSK</u>		
Physical Device Category	<u>Transmitter, DC-isolated Bus Device</u>		

HART Protocol

HART Protocol

Product Overview

HART communication is transmitted over the F-5500 4-20mA flow output signal and can be monitored and configured using a HART master device or a hand-held communicator.

Process Flow Rate 4-20mA Analog Output

The 4-20mA output of the F-5500 HART represents the process flow rate measurement, linearized and scaled according to the configured range of the instrument. This output corresponds to the Primary Variable. HART Communication is supported on this loop.

The 4-20mA output of the F-5500 should be configured for flow rate when using HART. If the 4-20mA output is set to report temperature, HART communication will report the 4-20mA value for temperature rather than flow.

HART Indicators

LED indicator LP3 cycles on and off to indicate that the F-5500 is operating. LED indicator LP2 blinks when HART signals are received and LP1 blinks when HART signals are transmitted (if nothing is connected to the 4-20mA output, LP2 will be on continuously).

HART Setup

F-5500 HART Communication Setup

HART communication must be selected in the F-5500 Serial Communication menu for HART communication to operate. When this communication parameter is changed, power to the F-5500 must be cycled for it to take effect.

Device Variables

This device does not expose any Device Variables.

Dynamic Variables

Four Dynamic Variables are implemented.

	Meaning	Units
PV	Flow Rate	In Selected Units
SV	Total	In Selected Units
TV	Temperature	In Selected Units
QV	Elapsed Time	In Hours

HART Programming

Status Information

Status Information
Device Status

Bit 4 ("More Status Available") is set when any failure is detected. Command #48 provides additional detail.

Extended Device Status

This bit is set if a sensor error is detected. "Device Variable Alert" is set if the PV is out of limit.

Additional Device Status

Additional Device Status (Command #48)

Command #48 returns 2 Device-Specific Status bytes of data, with the following status information:

These bits are set when an alarm or error condition is present. The bit automatically clears when the condition returns to its normal state.

Byte	Bit	Meaning	Class
0	0	Power up indication	Status
	1	High Flow Limit Alarm	Alarm
	2	Low Flow Limit Alarm	Alarm
	3	High Temperature Limit Alarm	Alarm
	4	Low Temperature Limit Alarm	Alarm
	5	Sensor out of range	Error
	6	Mix error	Alarm
	7	Check Parameter Settings	Error
1	0	In Simulation Mode	Alarm
	1	Frequency output out of range	Alarm
	2	CH 1 4-20mA out of range	Alarm
	3	Not used	
	4	Not used	
	5	Not used	
	6	CRC database error	Error
	7	Error with Total	Error

Modes

Fixed current mode is implemented, using Command 40. This mode is cleared by power loss or reset.

Damping

Damping is standard, affecting only the PV and the loop current signal.

HART Programming

Common
Commands

Common-Practice Commands, Supported Commands

The following common-practice commands are implemented:

- 34 Write Damping Value
- 35 Write Range Values
- 36 Set PV Upper Range Values
- 37 Set PV Lower Range Values
- 38 Reset "Configuration Changed" Flag
- 40 Enter/Exit Fixed Current Mode
- 44 Write PV Units
- 45 Trim Loop Minimum
- 46 Trim Loop Maximum
- 48 Read Additional Device Status (Command #48 returns 2 bytes of data)
- 59 Write Number of Response Preambles

Capability Checklist

Manufacturer, model	ONICON Inc, F-5500
Device type	Transmitter
HART revision	7.1
Device Description available	No
Number and type of sensors	1
Number and type of actuators	0
Number and type of host side signals	1 : 4-20mA analog
Number of Device Variables	0
Number of Dynamic Variables	4
Mappable Dynamic Variables	No
Number of common-practice commands	17
Number of device-specific commands	0
Bits of additional device status	8
Alternative operating modes	No
Burst mode	No
Write-protection	Yes

Common-Practice Commands, Unsupported Commands

Burst Mode- This device does not support Burst Mode.

Catch Device Variable- This device does not support Catch Device Variable.

Device-Specific Commands- No Device-Specific commands are implemented.

HART Programming

Programming HART

Enter the Programming Mode - HART

Press the F1 or the F2 key repeatedly, in the normal running mode, until the following screen is shown. This enters the programming mode:

SET PARAMETERS?	
NO	YES

F1 F2 F3 F4

Press **YES (F4)** and then the following screen will prompt the user to enter the password if enabled:

PASWD: _			
UP	DN	NXT	OK

F1 F2 F3 F4

Enter the correct password. Default password for Level 1 is 1234.

Communication Protocol and Parameters

To program the communication parameters, press **I/O (F1)** key from the main menu.

MAIN MENU			
I/O	FLO	DSP	EXIT

F1 F2 F3 F4

This is the main menu for the programming mode. To exit the programming mode, press **EXIT (F4)** repeatedly until "Normal Mode" is seen briefly. Choose **I/O (F1)** to access the communication output.

SET I/O			
COM	PUL	420	EXIT

F1 F2 F3 F4

Then press **COM (F1)** to select communication parameters

Set Bus protocol for HART:

Comm=HART	
NXT	OK

F1 F2 F3 F4

Press **NXT (F1)** until HART is selected as shown and then press **OK (F4)** to accept the setting.

Maintenance: Precautions

Precautions



PRECAUTIONS

WARNING! BEFORE ATTEMPTING ANY MAINTENANCE, TAKE THE NECESSARY SAFETY PRECAUTIONS BEFORE REMOVING THE PROBE FROM THE DUCT (EXAMPLE: PURGE LINES OF TOXIC AND/OR EXPLOSIVE GAS, DEPRESSURIZE, ETC...).



WARNING! EXPLOSION HAZARD. DO NOT REMOVE OR REPLACE COMPONENTS OR FUSES UNLESS POWER HAS BEEN DISCONNECTED WHEN A FLAMMABLE OR COMBUSTIBLE ATMOSPHERE IS PRESENT.



WARNING! EXPLOSION HAZARD. DO NOT DISCONNECT EQUIPMENT WHEN A FLAMMABLE OR COMBUSTIBLE ATMOSPHERE IS PRESENT.

Access to Electronics

Accessing electronics is not normally required for maintenance purposes. If a loose connection is suspected, unscrew the cap of the meter, unscrew the two phillips captive screws through the display and open the display assembly to access the wiring terminations.



CAUTION! BE SURE POWER TO METER IS SWITCHED OFF BEFORE ATTEMPTING TO ACCESS ELECTRONICS. If there is a problem and a loose connection is not found, please contact ONICON Customer Service for technical assistance at 727-447-6140.

Maintenance: General

Maintenance

Broken or Damaged Probe

If the sensor is broken or damaged, the probe and electronics must be returned to the factory. A new sensor will be installed and calibrated. Refer to "Returning Your Meter" on p. 93.

Flow Calibration and Calibration Validation

To ensure continued high accuracy of your Model F-5500 Flow Meter, ONICON Inc. provides a full NIST traceable calibration. It is recommended that the meter's accuracy be checked annually by performing the Zero CAL-CHECK® Calibration Validation test.

Fuse Replacement

WARNING! Turn input power OFF before removing or installing a fuse. Use only recommended fuse replacements.

Verify the fuse is defective by measuring it with an Ohm Meter (Two replacement fuses are provided with each unit). Replacement fuse is Littelfuse part number 0454.750MR

To replace the fuse:

The fuse F1 is located near the power terminal block and can be removed by using tweezers or needle-nose pliers.

Sensor Cleaning

The sensor is insensitive to small amounts of residue, but continued use in dirty environments will necessitate periodic cleaning. To inspect the sensor, remove power from electronics and remove the unit from the pipe or duct, exposing the sensor elements. If they are visibly dirty, clean them with water or alcohol (ethanol) using an appropriate brush until they appear clean again. Even though the sensor elements are rugged, avoid touching them with any solid object and use a light touch while cleaning them.



Troubleshooting: General

Troubleshooting Troubleshooting



CAUTION! The electronics and sensor supplied by ONICON are calibrated as a single precision mass flow meter. Interchanging sensors will decrease the accuracy of the flow meter. If you experience any problem with your Model F-5500 Flow meter, call ONICON Customer Service Department, Technical Assistance at 727-447-6140.

LED Indicators

The LED indicators near the terminal blocks of the F-5500 display the status of the F-5500. The Heartbeat LED blinks fast when the F-5500 is powered up, and blinks about once a second when the F-5500 operates normally.

The Transmit and Receive LEDs blink when messages are sent and received through serial communication. The Receive LED may be illuminated if the F-5500 has HART communication and the 4-20mA output is not connected.

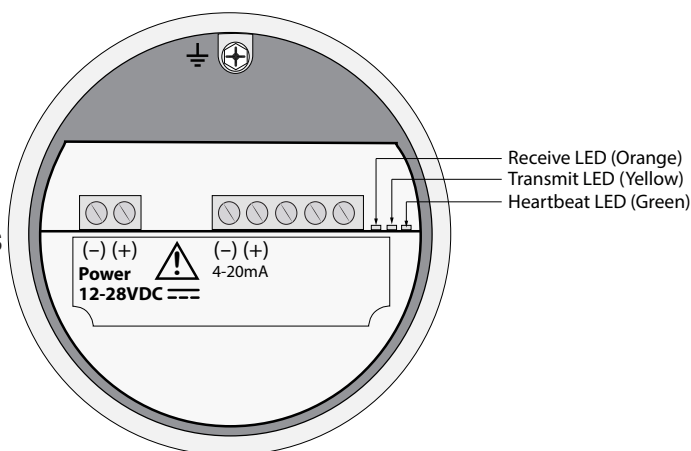

Problem	Possible Cause(s)	Action(s)
Display Error	1. Loose ribbon cable/ damaged ribbon cable	1. Visual inspection. 2. Cycle the power to reset the meter.
Flow measurement seems low	1. Probe not oriented properly 2. Sensor dirty	1. Orient probe per installation sections: Insertion (p. 18), Inline (p. 26) 2. Clean sensor (p. 79)
Unit will not power-up	1. No power input 2. Bad fuse 3. Bad Power supply	1. Check fuse (F1) located next to TS1 on main board. 2. Check for correct power supply voltage at TS1 on main board. If fuse is OK and unit still won't power up, call ONICON for additional assistance



Problem	Possible Cause	Action
Meter resets	<ol style="list-style-type: none"> 1. Intermittent power 2. Electromagnetic interference (EMI) 	<ol style="list-style-type: none"> 1. Measure the power input voltage 2. Check Power input and output cables grounding and routing. 3. Check meter power cycles value 4. Press and release F1 and F2 at the same time; the display will enter Engineering screens. 5. Press F1 to get to screen #23; record power cycle value. 6. Press F4 to return to normal operation; monitor meter until problem returns. 7. Return to screen #23 to see if power cycles have increased; microprocessor is resetting due to EMI electrical noise entering the meter.
Flow measurement is erratic or fluctuating	<ol style="list-style-type: none"> 1. Very turbulent flow 2. Sensor dirty 3. Sensor broken 4. Probe not mounted securely 5. Malfunction in flow meter 6. Meter installed incorrectly 	<ol style="list-style-type: none"> 1. Increase dampening (see filter settings in "Flow Parameters" on p. 51) 2. Clean sensor (Refer to Maintenance section, p. 79) 3. Return flow meter to ONICON for repair (Refer to p. 93 for shipping instructions) 4. Remount probe (see Installation section, p. 18); must be mounted securely without vibration. If vibration persists, choose a new mounting location without vibration. 5. Return flow meter to ONICON for repair (Refer to p. 93 for shipping instructions) 6. Re-install meter according to instructions (Refer to installation section, p. 18)



Troubleshooting: Zero CAL-CHECK®

Troubleshooting
Zero CAL-
CHECK®**Troubleshooting Zero CAL-CHECK®**

If the F-5500 Meter fails a Zero CAL-CHECK® Calibration Validation test, there are a few reasons that could be the cause:

1. The sensor may be dirty or damaged
 - Visually inspect the meter for damage. If damage is found, meter may need to be serviced. Contact ONICON Technical Assistance at 727-447-6140 for more information
 - Try cleaning the sensor and try the test again
 - If the meter fails again, move to #2
2. The sensor may not be properly covered/isolated
 - Out of Pipe:
 - Wind currents (fans in room included) could be affecting the sensor
 - Be sure to use a clean dry plastic bottle to isolate the sensor
 - In Pipe:
 - Make sure that there is a "no flow" or zero flow condition on the meter's sensor
 - Try the test again
 - If the meter fails again, move to #3
3. The meter may not have stabilized properly
 - Make sure the meter is not being affected by vibration or other movement
 - Allow the meter to stabilize without being moved or touched for 15 minutes
 - Try the test again
 - If the meter fails again, contact ONICON Technical Assistance at 727-447-6140



Troubleshooting: Installation Problems

Installation Problems

Installation Problems

The following is a summary listing of problems that may be encountered with the installation of the F-5500 Thermal Mass Flow Meter.

1. *Improper wiring connections for power and/or 4-20mA output signal.*

A separate power source is recommended for the F-5500 main board and the 4-20mA output signals. Two wires supply 24VDC power to the main board. Two wires are used for the 4-20mA output signals. Refer to "Fig. 3.2: 4-20mA Output Wiring for Customer-Supplied Power Source" on page 31 and "Fig. 3.3: 4-20mA Output Wiring for Loop Power Provided by F-5500" on page 32. Also refer to "Wiring Precautions" in Wiring section (p. 29) for further guidance.

2. *Inadequate power source.*

The F-5500 requires 12 to 28VDC at up to 6 Watts to operate. A 20 Watt power supply is recommended for powering the F-5500 to ensure it operates properly under all conditions. If the voltage supplied at the input terminals of the F-5500 is not within the range, a variety of problems will occur.

3. *Flow measurement seems inaccurate.*

- Check to ensure that the flow meter is installed so that the Flow Direction Indicator below the electronics housing is properly pointing in the direction of flow. Refer to "Fig. 2.5: Orientation of Flow Meter" on page 21. If not, change orientation of meter.
- Check that the insertion depth of the sensor/probe is correct. The end of the probe should be adjusted as per "Fig. 2.7a: Standard F-5500" on page 22.
- Ensure that there are a minimum of fifteen diameters of straight pipe upstream of the sensor and ten diameters downstream. If complex flow disturbances are upstream of the sensor, extension of the straight pipe may be required to ensure accurate flow measurement. Contact ONICON for assistance.
- Ensure that pipe inside diameter in the meter matches data on the ONICON Calibration Certificate. The pipe inside diameter is programmed into the flow meter through the front panel (see "Flow Parameters" on page 51).

4. *Erratic flow reading (especially a flow reading spiking high).*

This may be a symptom of moisture in the flow stream. ONICON flow meters are designed to work in relatively dry gas applications only. Contact ONICON to discuss resolutions to this problem.

**Installation Problems****5. *Flow meter is not responding to flow.***

Check to ensure adequate power is supplied to the flow meter. If things appear to be correct, perform this functional test before calling ONICON: carefully remove the probe and sensor from the pipe. Blow on the sensor to see if a response occurs. If nothing happens, take a damp rag or sponge and place it in contact with the sensor. A reading should occur. Contact ONICON Customer Service with this information.

6. *Display and/or 4-20mA signal reading above zero flow when no flow is occurring in the pipe.*

If the reading is less than 5% of full scale, it is likely this is a normal condition caused by convection flow created by the heated sensor. It does not mean that the zero of the instrument is improperly set. The ONICON sensor is extremely sensitive to gas flow and can even read the small flow caused by convection. If this is an unacceptable condition, please contact ONICON Customer Service for alternatives.

Troubleshooting: Alarm Codes



Alarm Codes

Alarm Codes

Information to diagnose and clear alarm codes is on p. 8 under the Menu Tree section. Enter password (9111) and follow the block diagram to get to the section affected by the error code.

Alarm Code	Reason	Action
13	Flow rate above high limits	Refer to the FLOW MENU 2 portion of the "Flow Parameters" section starting on p. 51 of this Manual to verify limit is within range. Check ALM = HiFloAlm under PRM.
14	Flow rate below low limits	Refer to the FLOW MENU 2 portion of the "Flow Parameters" section starting on p. 51 of this Manual to verify limit is within range. Check ALM = LoFloAlm under PRM.
15	Temperature above high limits	Refer to the FLOW MENU 2 portion of the "Flow Parameters" section starting on p. 51 of this Manual to verify limit is within range. Check ALM=HiTempAlm under PRM.
16	Temperature below low limits	Refer to the FLOW MENU 2 portion of the "Flow Parameters" section starting on p. 51 of this Manual to verify limit is within range. Check ALM = LoTempAlm
25	Simulation mode	Meter is in Simulation Mode. Refer to the FLOW MENU 1 section on p. 56 of this Manual. Use the SIM Section under Diagnostics to return to normal operation.
26	Pulse/alarm output over range	Refer to the DIGITAL OUTPUT MENU on p. 6 of this Manual. Verify the Pulse/alarm Output settings are within limits.
32	CH1 - 4-20mA is out of range	Refer to the MAIN MENU on p. 5 of this Manual. Use the Set I/O section to verify range limits.
36	Database CRC Error	Refer to the Reset CRC section on p. 55 of this manual. Verify the programmed values are verified and corrected before clearing the error. Contact ONICON Service Department for possible causes.
37	Total Alarm Error	Refer to the RESET TOTAL section on p. 56 of this Manual to reset total.

Appendices: Specifications

Performance & Operating Specs

Performance Specs

Flow Accuracy:

Natural Gas and Propane: 1% R 500 - 7000 SFPM

Natural Gas and Propane: 2% R 100 - 500 SFPM

Air: $\pm 1\%$ of reading $\pm 0.5\%$ of full scale

Accuracy specification applies to customer's selected flow range

Maximum range: 15 to 35,000 SFPM (0.07 to 71 NMPS)

Minimum range: 15 to 1,000 SFPM (0.07 to 4.7 NMPS)

Flow Response Time: 1 second (one time constant)

Temperature Accuracy: $\pm 1^\circ$ F ($\pm 0.6^\circ$ C)

Calibration:

Factory Calibration to NIST traceable standards

Zero CAL-CHECK®: In situ, operator-initiated calibration validation

Operating Specs

Units of Measurement (field selectable):

SCFM, SCFH, NM³/H, NM³/M, KG/H, KG/M, KG/S, LB/H, LB/M, LB/S, NLPH, NLPM, MMSCFD, LB/D, SLPM, NLPS, MSCFD, SM³/H, MT/H, NM³/D, MMSCFM, SCFD, MCFD, SM³/M, SM³/D

Flow Velocity Range:

15 to 35,000 SFPM (0.07 to 71 NMPS)

Turndown: up to 1000:1; 100:1 typical

Flow Ranges		
Pipe Diameter	SCFM	NM ³ /hr
1.5" (40mm)	0-210	0-330
2" (50mm)	0-350	0-550
3" (80mm)	0-770	0-1,210
4" (100mm)	0-1,330	0-2,100
6" (150mm)	0-3,000	0-4,730
8" (200mm)	0-5,210	0-8,220
12" (300mm)	0-11,700	0-18,450



NOTE: To determine if the F-5500 will operate accurately in other pipe sizes, divide the maximum flow rate by the pipe area. The application is acceptable if the resulting velocity is within the velocity range above.

Appendices: Specifications

Operating Specs

Gas Pressure (maximum):

Insertion:

Standard Process adapter fitting: 60 psig (4.1 barg)

High Pressure Process Adapter Fitting: 150 psig (10.3 barg)

Inline:

Flanged, ANSI 150: 230 psig at 100°F (16 barg)

NPT: 300 psig (20.7 barg)

Relative Humidity: Non-condensing

NOTE: Condensing liquids contacting the sensor can cause erratic flow indication.

Temperature:

DDC-Sensor™: -40 to 250°F (-40 to 121°C)

Enclosure: -40 to 158°F (-40 to 70°C)*

*NOTE: Display dims below -4°F (-20°C), function returns once temperature rises again.

Input Power: 12 to 28VDC, 6 watts minimum (CE requirement)

Full Input Power Range: 10 to 30VDC.

A 20 Watt or greater power supply is recommended to power the F-5500.

Outputs:

Channel 1:

Standard isolated 4-20mA output configured to indicate either flow or temperature; fault indication per NAMUR NE43.

The 4-20mA load resistance must be 125 ohms or less when operating on 12 volt power and 600 ohms or less on 24 volt power.

HART communication option

Channel 2:

F-5500 can be ordered with either the pulse output or serial communication option.

- Pulse option: Isolated open collector output rated for 5 to 24VDC, 10mA maximum load. The output can be configured as a 500ms scaled pulse for totalization or as an on/off indication.
- Serial communication option: Isolated RS485 Modbus RTU or BACnet MS/TP.

USB Communication:

Isolated mini USB 2.0 for interfacing with a laptop or computer is standard.

F-5000 View: A free PC-based software tool that provides complete configuration, remote process monitoring, and data logging functions through USB communication.

4-20mA and Pulse Verification:

Simulation mode used to align 4-20mA output and pulse output (if ordered) with the input to customer's PLC/DCS.



Appendices: Specifications

Physical Specs**Physical Specs**

Sensor material:
316 stainless steel

Enclosure:
NEMA 4X, aluminum, dual ¾" FNPT conduit entries

Flow Meter Installation for Insertion Meters:
ONICON-supplied process adapter fitting connects to ONICON or customer-supplied
1" ball valve, nipple, and weldolet assembly.

**Agency
Approvals****Agency Approvals**

CE Mark
EMC Directive; 2014/30/EU
Emissions and Immunity Testing: EN61326-1:2013

FM (USA) and FMc (Canada): Approved
Class I, Division 1, Groups B,C,D;
Class II, Division 1, Groups E,F,G;
Class III, Division 1; T4, Ta = - 40°C to 70°C;
Class 1, Zone 1, AEx/Ex db IIB + H2 T4; Gb Ta= -40°C to 70°C;
Type 4X, IP66/67

Appendices: Dimensions

Insertion with
Process
Adapter
Fitting

Fig. 7.1 Insertion Meter with Process Adapter Fitting Dimensions
Measurements shown in inches (millimeters).

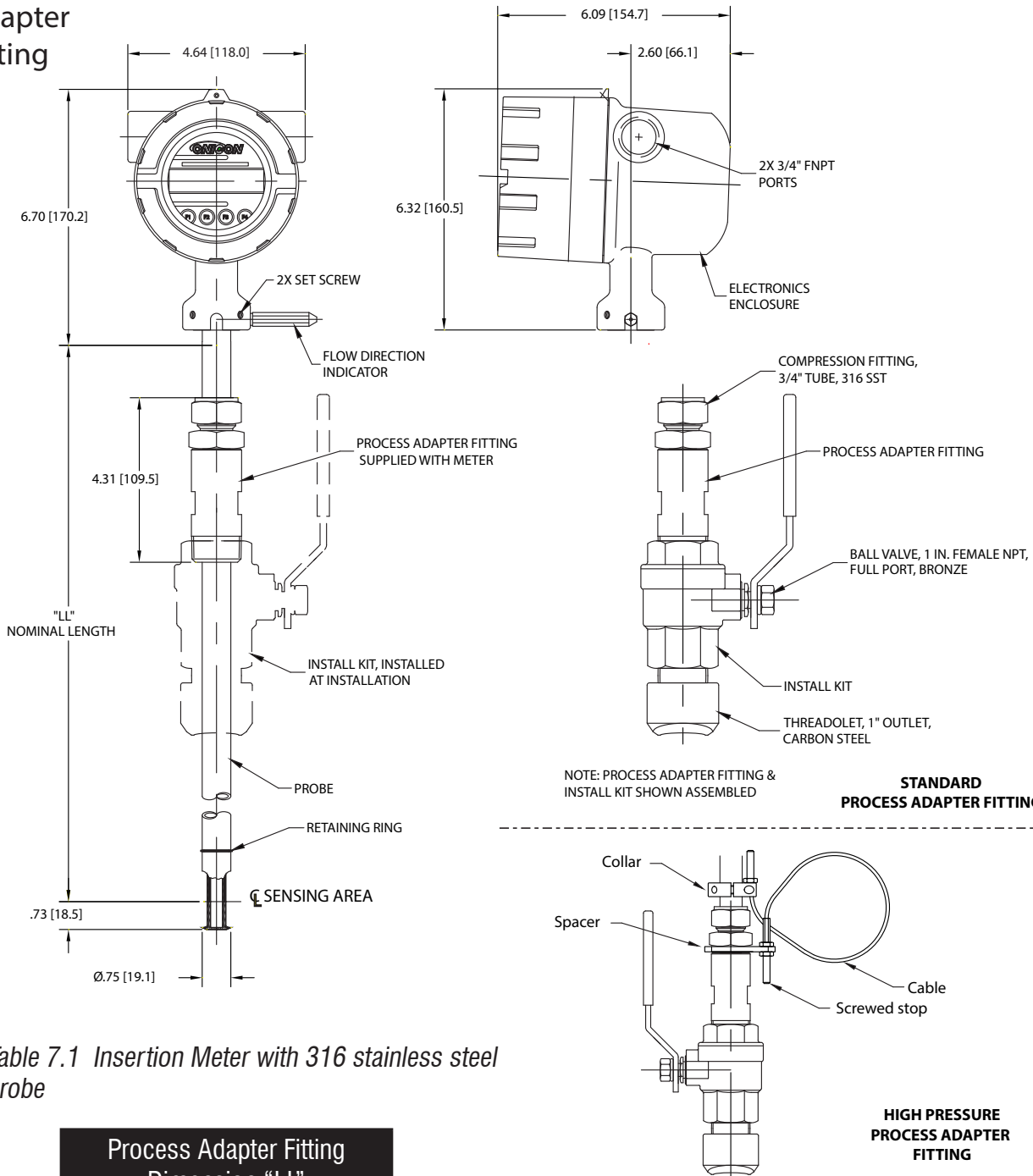

Table 7.1 Insertion Meter with 316 stainless steel probe

Process Adapter Fitting Dimension "LL"
[inches / millimeters]
15.0" (381 mm)
18.0" (457 mm)

APPENDICES

Appendices: Dimensions

Inline NPT Meter *Fig. 7.2: Inline Meter with 316 Stainless Steel Flow Body and NPT End Connections Dimensions*

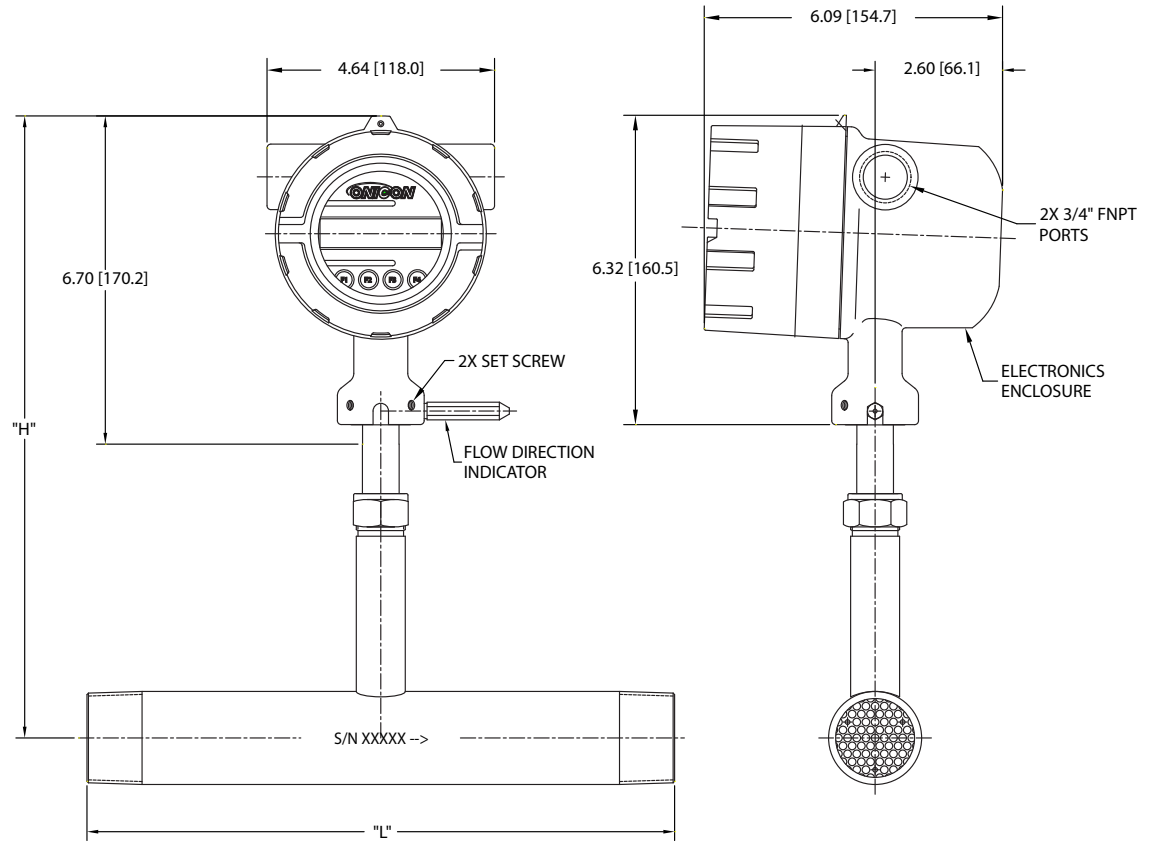

Table 7.2 *Inline Meter with 316 stainless steel flow body and NPT End Connections*

Body Size [inches]	Dimension "L" [inches]	Dimension "H" [inches / millimeters]
0.75"	12"	10.70" (272mm)
1.00"	12"	10.70" (272mm)
1.25"	12"	10.70" (272mm)
1.50"	12"	12.70" (323mm)
2.00"	12"	12.70" (323mm)
2.50"	18"	12.70" (323mm)
3.00"	18"	12.70" (323mm)

Appendices: Dimensions

Inline
Flange Meter

Fig. 7.3: Inline Meter with 316 Stainless Steel Flow Body and 150# RF Flange End Connections Dimensions

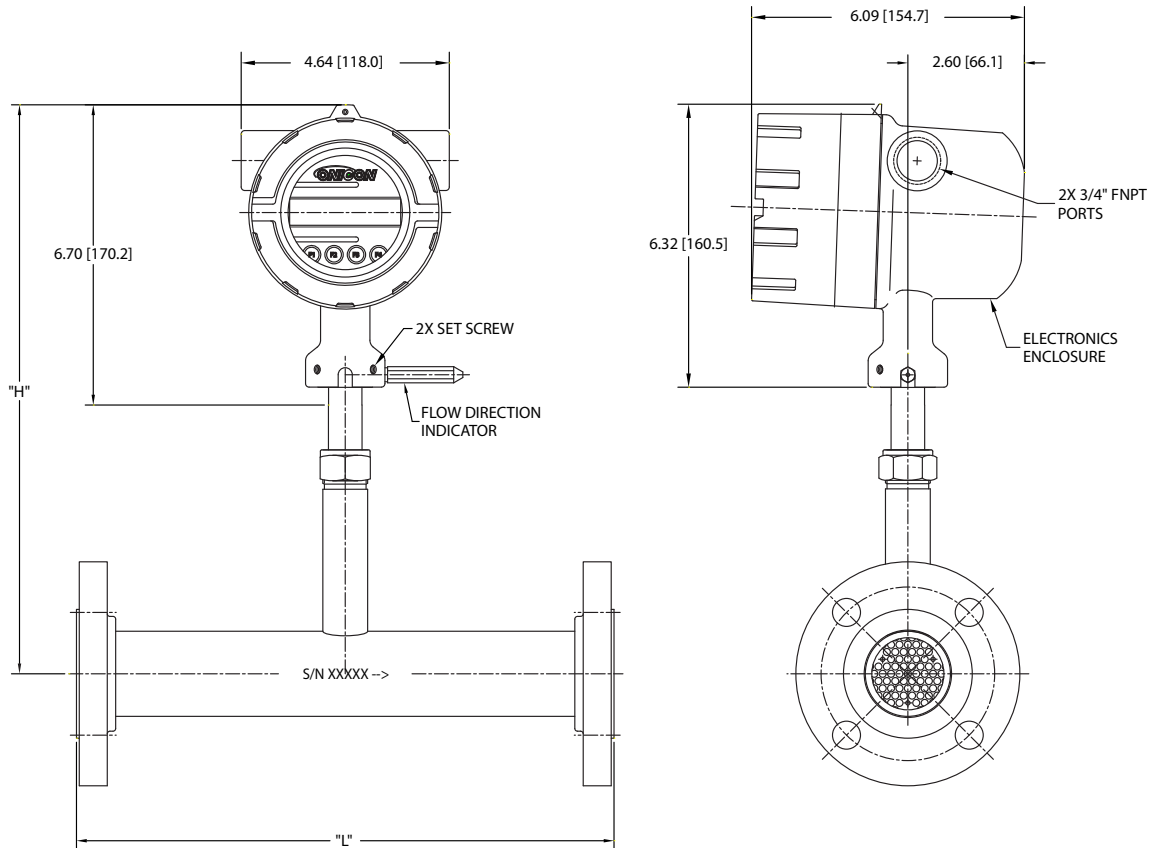

Table 7.3 Inline Meter with 316 stainless steel flow body and 150# RF Flange End Connections

Body Size [inches]	Dimension "L" [inches]	Dimension "H" [inches / millimeters]
0.75"	12"	10.70" (272mm)
1.00"	12"	10.70" (272mm)
1.25"	12"	10.70" (272mm)
1.50"	12"	12.70" (323mm)
2.00"	12"	12.70" (323mm)
2.50"	18"	12.70" (323mm)
3.00"	18"	12.70" (323mm)
4.00"	18"	12.70" (323mm)
6.00"	24"	12.70" (323mm)

Appendices: Warranty

Warranty

Warranty

(a) ONICON warrants that the products furnished under this Agreement will be free from defects in material and workmanship for a period of two years from the date of shipment. The customer shall provide notice of any defect to ONICON, within one week after the Customer's discovery of such defect. The sole obligation and liability of ONICON, under this warranty shall be repair or replace, at its option, without cost to the Customer, the defective product or part.

(b) Upon request by ONICON, the product or part claimed to be defective shall immediately be returned at the Customer's expense to ONICON. Replaced or repaired products or parts will be shipped to the Customer at the expense of ONICON. ONICON shall have the right of final determination as to the existence and cause of defect.

(c) There shall be no warranty or liability for any products or parts that have been subject to misuse, accident, negligence, failure of electric power or modifications by the Customer without the written approval of ONICON. Final determination of warranty eligibility shall be made by ONICON. If a warranty claim is considered invalid for any reason, the Customer will be charged for services performed and expenses incurred by ONICON, in handling and shipping the returned unit.

(d) The liability of ONICON shall be limited to replacing or repairing, at its option, any defective parts which are returned. Labor and related expenses incurred to install replacement parts are not covered by this warranty.

(e) As to replacement parts supplied or repairs made during the original warranty period, the warranty period for the replacement or repaired part shall terminate with the termination of the warranty period of the original product or part.

(f) The use of these products is under exclusive control of the purchaser and ONICON specifically denies any responsibility for the calibration of units and/or accuracy of work performed or the safety of the system in which ONICON products is used. **EXTERNAL SAFETY DEVICES MUST BE USED WITH THIS EQUIPMENT.**

(g) No warranty is made with respect to custom equipment or products produced to Buyer's specifications except as specifically stated in writing by ONICON and contained in the agreement.

(h) **THE FOREGOING WARRANTY CONSTITUTES THE SOLE LIABILITY OF ONICON, AND THE CUSTOMER'S SOLE REMEDY WITH RESPECT TO THE PRODUCTS AND IS IN LIEU OF ALL OTHER WARRANTIES, INCLUDING ANY WARRANTY OF MERCHANTABILITY OR FITNESS FOR A PARTICULAR PURPOSE, LIABILITIES, AND REMEDIES. EXCEPT AS THUS PROVIDED, ONICON, DISCLAIMS ALL WARRANTIES, EXPRESS OR IMPLIED, INCLUDING ANY WARRANTY OF MERCHANTABILITY OR FITNESS FOR A PARTICULAR PURPOSE.**

Appendices: Returning Your Meter

Returning Your Meter

Returning Your Meter

The ONICON Customer Service Department (PH: 727-447-6140 or FAX: 727-442-5699) can help you through the process of returning a meter for service.

If it becomes necessary to return a ONICON flow meter for service or recalibration, please follow these steps:

1. A Return Material Authorization (RMA) Number must be obtained from the ONICON Customer Service Department prior to returning any ONICON meter(s).
2. Please have your meter's serial number(s) available.
3. Read and complete the ONICON RMA Customer Information Form. Be sure to initial the decontamination statement as well as provide complete return shipping instructions (we cannot deliver to post office boxes).
4. The entire flow meter must be returned, including all electronics (unless specifically instructed to do otherwise). **ALL** serial numbers must match their corresponding meters. This is especially necessary when returning flow body models.
5. Clean and decontaminate all wetted parts before returning to ONICON.
6. Ship the meter to the following address:

ONICON
399 Reservation Road
Marina, CA 93933
Attn: Service Dept.
[RMA Number]



NOTE: Be sure to review all of the information on the Customer Information Form before sending your meter to the ONICON Customer Service Department. The ONICON Shipping/Receiving Department cannot accept meters that have not been prepared appropriately.

What to Expect During Servicing

What to expect while your meter is being serviced

Depending on the type of service required when returning your ONICON meter, there are varying turnover times for servicing a meter. The average time needed to service the meter is 7-10 days (not including shipping or peak production times).

If you have already shipped your meter to ONICON for servicing and would like to check the status of your meter, please fill out our online Service Order Status form located at www.onicon.com and you will hear from a Customer Service Rep within 1 business day of your requested update.

Rush recalibration service is available for a fee. Restrictions apply.

Glossary of Terms and Definitions

AWG	American Wire Gauge	NL	Normal Liter
Bara	Bar absolute	NLPH	Normal Liter per Hour
CTC	Contact	NLPM	Normal Liter per Minute
CAL	Calibration	NM3	Normal cubic Meter
CHG	Change	NM3/H	Normal cubic Meter per Hour
COM	Communication	NM3/M	Normal cubic Meter per Minute
CSV	Current Sense Voltage	NPT	National Pipe Thread
DC	Direct Current	PDA	Personal hand held computer
DN	Down	PC	Personal Computer
DSP	Display	P/U	Pulse per Unit
ELP	Elapsed time	PIP A ²	Pipe Area
Feq	Frequency	PLC	Programmable Logic Controller
Ft ²	Square Feet	PRM	Parameters
I/O	Input/Output	PRS	Pressure
INP	Input	PSIA	Pounds per Square Inch Absolute
LB	Pound	Pt	Point
LB/D	Pound per Day	PSW	Password
LB/H	Pound per Hour	SIM	Simulation
LB/M	Pound per Minute	SCF	Standard Cubic Feet
LB/S	Pound per Second	SCFM	Standard Cubic Feet per Minute
LCD	Liquid Crystal Display	SCFH	Standard Cubic Feet per Hour
KG	Kilogram	SCFD	Standard Cubic Feet per Day
KG/H	Kilogram per Hour	SPC	Special Control
KG/M	Kilogram per Minute	STP	Standard Temperature and Pressure
KG/S	Kilogram per Second	TMP	Temperature
M ²	Square Meter	TSI	Internal Variable
mmHG	Pressure in millimeters of mercury	TSV	Internal Variable
MMSCFD	Million Standard Cubic Feet per Day	UNT	Unit
MXFLO	Maximum Flow	U/P	Unit per Pulse
NEMA	National Electrical Manufactures Association	420	4-20mA output
NIST	National Institute of Standards and Technology		

Index

Index

Access to Electronics, Page 28
 Alarm Codes, p. 85
 Alarm wiring, p. 33
 Analog 4-20mA output, p. 42
 Breakage or Damage of Probe, p. 79
 Dimension Details, p. 89
 Discrete output setting, p. 45
 Display Screens, p. 40
 Display Setup, p. 46
 Engineering Screens, p. 11
 Entering the programming mode, p. 41
 Equal length sensors, p. 21
 Filter value, p. 52
 Flow Meter Placement, p. 18
 Flow Units, p. 48
 Pulse/alarm Output, p. 43
 Fuse Replacement, p. 79
 Glossary, p. 94
 Installation,
 Compression Fitting - Insertion, p. 24
 General Precautions, p. 17
 Lateral Placement, p. 18
 Mounting, p. 18
 Orientation of Meter - Insertion, p. 24
 Introduction, p. 12
 K Factor, p. 54
 Level 2 password, p. 48
 Local Display, p. 14
 Local Input Wiring, p. 30
 Mass Flow, p. 12
 Measurement Mode, p. 40
 Menu Tree,
 Digital Output, p. 6
 Display Menu, p. 9
 Engineering Display, p. 10
 Main Menu, p. 5
 Flow Menu 1, p. 7
 Flow Menu 2, p. 8
 Zero CAL-CHECK® Menu, p. 10
 Mounting meter, p. 18
 Orientation of meter - Insertion type, p. 24
 Password
 Level 1, p. 48
 Level 2, p. 48
 Programming, p. 48
 Power Input Wiring, p. 30
 Preventative Maintenance, p. 79
 Product Description, p. 12

Programming

Analog 4-20mA Output, p. 42
 Alarm Output, p. 45
 Changing values or strings, p. 41
 Display Setup, p. 46
 Filter value, p. 52
 Flow cutoff, p. 51
 Flow Parameters, p. 51
 Flow and maximum pulse/alarm, p. 43
 High Alarm Limit value, p. 52
 Pulse/alarm Output, p. 43
 K Factor, p. 54
 Low Alarm Limit value, p. 52
 Password, p. 48
 Pipe Diameter, p. 52
 Programming Mode, p. 41
 Restore Database, p. 54
 Reset CRC, p. 55
 Reset Total/Elapsed Time, p. 56
 Selecting from a list, p. 41
 Serial Communication, p. 46
 Simulation, p. 56
 Unit-per-pulse, p. 44
 Unit settings, p. 48
 Using the Local Display, p. 41
 Replacements Fuses, p. 79
 Restore Database, p. 54
 Reset Total/Elapsed Time, p. 56
 Return Procedure, p. 93
 Sensor Cleaning, p. 79
 Sensor Orientation, p. 24
 Simulation Mode, p. 56
 Theory of Operation, p. 12
 To program the display, p. 47
 Totalizer Rollover, p. 56
 Troubleshooting, p. 80
 Alarm Codes, p. 85
 General, p. 81
 Installation Problems, p. 83
 USB Interface, p. 39
 Warranty, p. 89
 Wiring
 Alarms, p. 33
 Pulse/Alarm Outputs, p. 33
 Grounding, p. 29
 Input - Local, p. 30
 Instructions, p. 24
 Local meters, p. 30
 Power Input, p. 30
 Precautions, p. 29



Wiring



Definition of Terms



Troubleshooting Tips



Information



**Caution - (refer to accompanying documents):
Please follow the specified instructions and
general safety practices.**



**Indicates compliance with the WEEE Directive.
Please dispose of the product in accordance
with local regulations and conventions.**



**Indicates compliance with the applicable
European Union Directives for Safety and
EMC (Electromagnetic Compatibility Directive
2014/30/EU).**