



**DeVilbiss**  
HEALTHCARE

FAA  
Approved  
for air travel!



## MODEL 306DS INSTRUCTION GUIDE

CE 0044



### EN DeVilbiss iGo® Portable Oxygen System

**WARNING**– Read instruction guide before operating this equipment.

**CAUTION**– Federal (U.S.A.) law restricts this device to sale by or on the order of a physician.

 **DANGER–NO SMOKING**

### ES Sistema de oxígeno portátil DeVilbiss iGo®

**ADVERTENCIA**– Lea la guía de instrucciones antes de poner a funcionar este equipo.

**PRECAUCIÓN**– La ley federal de EE. UU. limita la venta de este dispositivo a médicos o a personas que dispongan de la correspondiente orden médica.

 **PELIGRO–NO FUMAR**

### FR Système d’approvisionnement portable en oxygène DeVilbiss iGo®

**AVERTISSEMENT**– Lisez ce guide d’instructions avant d’utiliser l’équipement.

**ATTENTION**– En vertu de la loi fédérale américaine, cet appareil ne peut être vendu que par un médecin ou sur ordonnance de celui-ci.

 **DANGER–NE PAS FUMER**

### DE Tragbares DeVilbiss iGo® Sauerstoffsystem

**WARNUNG**– Vor Inbetriebnahme des Gerätes Bedienungshinweise lesen.

**ACHTUNG**– Nach US-Bundesgesetzen darf dieses Gerät nur von einem Arzt bzw. auf Anordnung eines Arztes verkauft werden.

 **GEFAHR–RAUCHEN VERBOTEN**

### IT Sistema portatile DeVilbiss iGo® per ossigenoterapia™

**AVVERTENZA**– Non mettere in funzione l’apparecchiatura senza aver prima letto le istruzioni riportate in questo manuale.

**ATTENZIONE**– La legge federale statunitense limita la vendita di questo dispositivo ai medici o su loro prescrizione.

 **PERICOLO – VIETATO FUMARE**

### NL DeVilbiss iGo® draagbaar zuurstof-systeem

**WAARSCHUWING**– Lees dit instructiehandboekje zorgvuldig door voordat u het apparaat gaat gebruiken.

**ATTENTIE**– De federale wetgeving in de Verenigde Staten schrijft voor dat dit apparaat uitsluitend mag worden verkocht of voorgeschreven door een arts.

 **GEVAAR– VERBODEN TE ROKEN**

# IMPORTANT PARTS

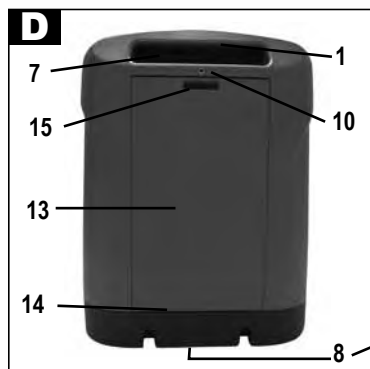
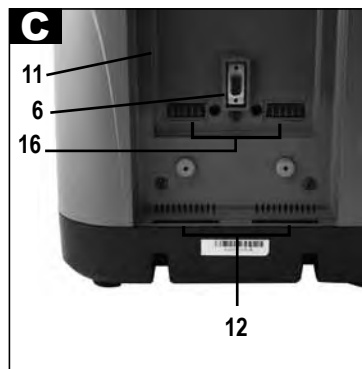
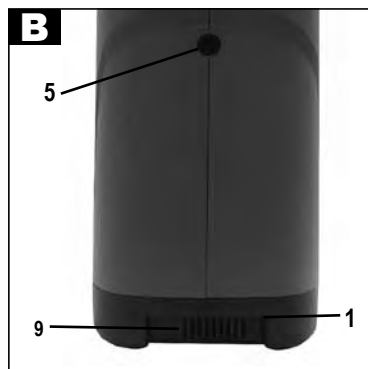
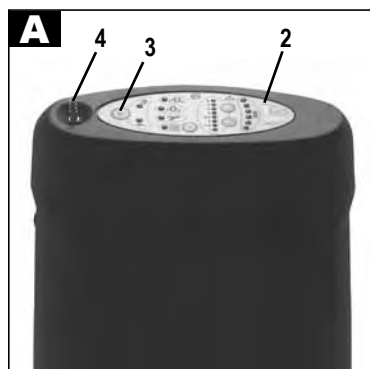

**DEVILBISS® iGo®**  
Portable Oxygen System

DeVilbiss HEALTHCARE  
3000 Royall Drive  
Somerset, PA 15501 U.S.A.

REF Catalog No.: 306DS SN EXXXXXXS

CONSULT ACCOMPANYING DOCUMENTS

IPX1  
Battery Mode Only

WARNING: No Smoking

NOTE:  
Use DeVilbiss Battery P/N: 306D-413 only.  
Use DeVilbiss AC Adapter P/N: 306DS-651 only.  
Use DeVilbiss DC Adapter P/N: 306DS-652 only.

CAUTION:  
Federal (U.S.A.) law restricts this device to sale by or on the order of a physician.

91% +/- 3% at 3 L/min Continuous Flow

No User Serviceable Parts. Removal of the cover by authorized personnel only.

MADE IN THE USA

CE 0044

Intertek

306DS-013 Rev. E

# iGO CONTROL PANEL

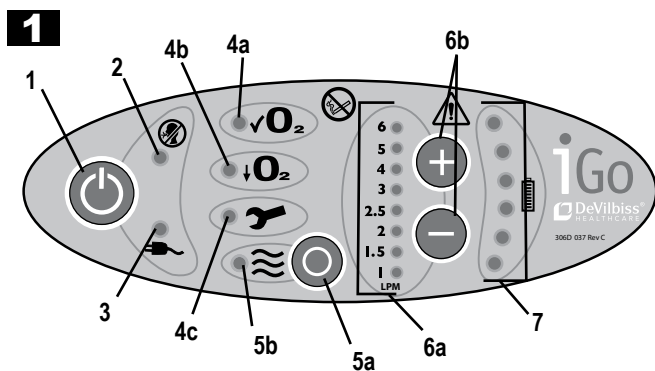

EN ENGLISH.....	EN-3
ES ESPAÑOL .....	ES-13
FR FRANÇAIS.....	FR-24
DE DEUTSCH.....	DE-35
IT ITALIANO.....	IT-46
NL NEDERLANDS .....	NL-57

# IMPORTANT PARTS

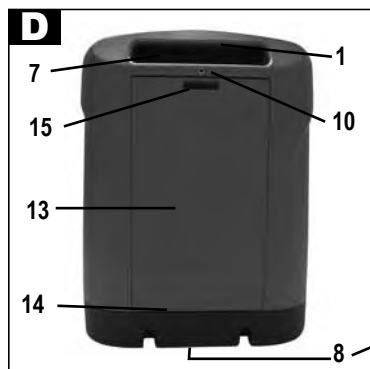
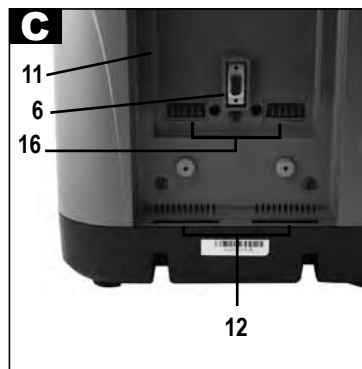
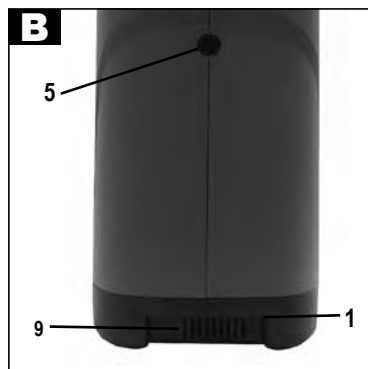
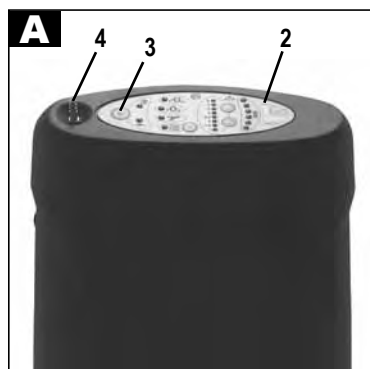

**DEVILBISS® iGo®**  
Portable Oxygen System

DeVilbiss HEALTHCARE  
3000 Rock Hill Drive  
Somerset, PA 15501 U.S.A.

REF Catalog No.: 306DS SNI EXXXXXDS

CONSULT ACCOMPANYING DOCUMENTS

IPX1  
Battery Mode Only

WARNING: No Smoking

NOTE:  
Use DeVilbiss Battery P/N: 306D-413 only.  
Use DeVilbiss AC Adapter P/N: 306DS-651 only.  
Use DeVilbiss DC Adapter P/N: 306DS-652 only.

CAUTION:  
Federal (U.S.A.) law restricts this device to sale by or on the order of a physician.

91% +/- 3% at 3 L/min Continuous Flow

No User Serviceable Parts. Removal of the cover by authorized personnel only.

MADE IN THE USA

CE 0044

Intertek

306DS-013 Rev. E

# iGO CONTROL PANEL

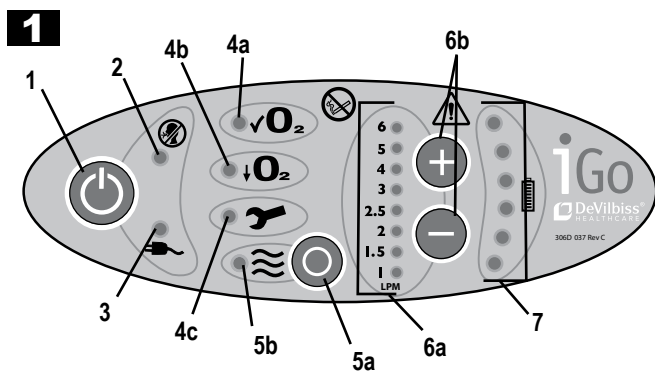

EN ENGLISH.....	EN-3
ES ESPAÑOL .....	ES-13
FR FRANÇAIS.....	FR-24
DE DEUTSCH.....	DE-35
IT ITALIANO.....	IT-46
NL NEDERLANDS .....	NL-57

## TABLE OF CONTENTS

Important Safeguards.....	EN - 3
Dangers/Warnings/Cautions/Notes.....	EN - 3
Physician Notes.....	EN - 4
Provider Checklist.....	EN - 4
IEC Symbols and Symbol Definitions.....	EN - 5
Indications for Use.....	EN - 5
Important Parts of Your DeVilbiss iGo Personal Oxygen System	
iGo Portable Oxygen System and Accessories.....	EN - 5
iGo Control Panel.....	EN - 5
Accessories.....	EN - 6
Setting Up Your iGo Portable Oxygen System.....	EN - 6
Before Operating Your iGo.....	EN - 6
Selecting the iGo Power Source.....	EN - 6
AC Operation.....	EN - 7
DC Operation.....	EN - 7
Battery Operation.....	EN - 7
Initial Battery Operation.....	EN - 8
Typical Battery Recharge Time.....	EN - 8
Operating Your iGo.....	EN - 8
Travel.....	EN - 9
Reserve Oxygen System.....	EN - 9
Troubleshooting.....	EN - 9
Caring for Your iGo System.....	EN - 10
Specifications.....	EN - 11
Guidance and Manufacturer's Declaration.....	EN - 12

## IMPORTANT SAFEGUARDS

When using electrical products, especially when children are present, basic safety precautions should always be followed. Read all instructions before using. Important information is highlighted by these terms:

**DANGER** Urgent safety information for hazards that will cause serious injury or death.

**WARNING** Important safety information for hazards that might cause serious injury.

**CAUTION** Information for preventing damage to the product.

**NOTE** Information to which you should pay special attention.

Important safeguards are indicated throughout this guide; pay special attention to all safety information.

### READ ALL INSTRUCTIONS BEFORE USING.

## SAVE THESE INSTRUCTIONS

### DANGER



#### DANGER - NO SMOKING

- Oxygen causes rapid burning. DO NOT SMOKE WHILE USING YOUR DEVILBISS OXYGEN EQUIPMENT or when you are near a person utilizing oxygen therapy. Keep matches, cigarettes, burning tobacco, or candles away from the area where the system is being stored or operated.
- To reduce the risk of fire, burns, or injury to persons:  
Oxygen, though non-flammable, vigorously supports and accelerates burning of any flammable material. If you know or suspect oxygen has escaped other than through normal operation, open doors and windows to ventilate the area.
- To prevent high concentrations of oxygen:  
Do not leave iGo running when not in use. Do not leave cannula unattended while unit is delivering oxygen. High concentrations of oxygen can cause rapid burning. Keep the equipment in a well-ventilated area.
- Keep the iGo at least 5 feet (1.6 m) from hot, sparking objects or open sources of flame. Position your unit at least 6 inches (16 cm) from walls, draperies, or any other object that might prevent the proper flow of air in and out of your iGo. The iGo should be located so as to avoid pollutants or fumes.
- Use No Oil or Grease: A spontaneous and violent ignition may occur if oil, grease, or other petroleum substances come into contact with oxygen under pressure. Keep these substances away from the oxygen system, tubing and connections, and any other oxygen source. DO NOT use any petroleum based or other lubricants.
- Avoid creation of any spark near oxygen equipment. This includes sparks from static electricity created by any type of friction.
- Never use aerosol sprays or flammable anesthetics near the equipment.
- Electric Shock Hazard. Do not disassemble. The DeVilbiss iGo Portable Oxygen System contains no user serviceable parts. If service is required, contact your DeVilbiss provider or authorized service center.

### WARNING

- Keep all units away from children. Do not allow unauthorized or untrained individuals to operate the equipment. Never tamper with or try to repair the equipment yourself. If you have any questions or suspect your equipment is not operating properly, contact your oxygen provider.
- If the iGo has a damaged cord or plug, if it is not working properly, if it has been dropped or damaged, or if it has been submersed in water, do not use and call a qualified technician for examination and repair

- The iGo is equipped with a High Pressure Relief Valve to ensure the user's safety.
- Changing the L/min. setting will affect the dose of oxygen delivered, DO NOT readjust the L/min. setting unless directed by your physician.
- DO NOT ignore alerts. The iGo is not intended for life supporting or life sustaining applications, nor does it provide any patient monitoring capabilities. Consult your physician for the type of back-up system required.
- DO NOT leave the iGo or DC Adapter plugged into the vehicle without the engine running or attempt to start the vehicle while the DC Adapter is connected to the vehicle. This may drain the vehicle's battery.
- DO NOT operate device or accessories in standing water and DO NOT submerge or expose to water. Electric shock or damage to the unit may result.
- Protect the Battery and AC/DC Adapters from fluid spills or drips to avoid possible shock hazards.
- The Rechargeable Battery may explode and cause potential injury if exposed to or disposed of in a fire.
- DO NOT short circuit the battery's metal contacts with metallic objects such as keys or coins. It may cause sparks or excessive heat.
- DO NOT disassemble, puncture, or crush the Battery. Rechargeable Battery electrolytes may be toxic if swallowed and can be harmful to skin and eyes. Use of a damaged Battery may cause personal injury. Keep the Battery away from children.
- This device contains electrical and/or electronic equipment. Follow local governing ordinances and recycling plans regarding disposal of device components.
- Equipment not suitable for use in the presence of a flammable anesthetic mixture with air or with oxygen or nitrous oxide.

## CAUTIONS

- Federal (U.S.A.) law restricts this device to sale by or on the order of a physician.
- Do not use in an area where the air may be contaminated with carbon monoxide or hydrocarbons as this may shorten the life of the unit (i.e. near running gasoline engines, furnace, or heater).
- Use only the iGo AC Adapter and DC Adapter supplied with your iGo. Use of another power supply will void the warranty. Do not use parts, accessories, or adapters other than those authorized by DeVilbiss.
- Locate oxygen tubing and power supply cords to prevent tripping hazards.
- Do not use with other equipment (i.e. humidifier, nebulizer, etc.) when in PulseDose® delivery mode.
- DO NOT expose unit to temperature outside of specified operating or storage temperatures as this may damage the unit. DO NOT expose the Rechargeable Battery to temperatures above 140°F (60°C) such as in a vehicle parked in the sun or on a hot day.
- If the External Power light flashes and the audible alert sounds but the unit is not operating, there is no power to the unit. Refer to Troubleshooting and contact your DeVilbiss provider if necessary.
- Do not place this device near other equipment or devices that create or attract electromagnetic fields. Placing the unit in electromagnetic fields greater than 10 V/m can affect its operation. Examples of such equipment are defibrillators, diathermy equipment, cellular telephones, CB radios, radio-controlled toys, microwave ovens, etc.

## PHYSICIAN'S/RESPIRATORY THERAPIST'S NOTES

1. Use only continuous flow mode of operation with patients who breathe below 6 Breaths Per Minute (BPM); refer to specifications for maximum breath rate.
2. Use only continuous flow mode of operation with patients who consistently fail to trigger equipment (i.e. mouth breathing with closed soft palates).
3. PulseDose settings should be determined for each patient individually. Settings from continuous flow applications may not be applicable to PulseDose mode.
4. Verify patient is getting adequate PaO<sub>2</sub> or SaO<sub>2</sub> levels in PulseDose delivery mode.
5. Use only standard nasal cannula with PulseDose delivery. Do not use pediatric (low-flow) nasal cannula with PulseDose delivery. Any nasal cannula can be used with continuous flow delivery.
6. PulseDose settings should be determined for each patient individually. Settings from Continuous Flow applications may not be applicable to PulseDose Mode.
7. Do not use with other equipment (i.e. humidifier, nebulizer, etc.) when in PulseDose delivery mode.

## PROVIDER'S CHECKLIST

























1. Upon arrival, check the iGo for damage that may have occurred during shipping and notify DeVilbiss of any damage. (Obvious shipping damage should be reported within 10 calendar days after arrival.) Do not use damaged equipment. Save the carton, noting the position of the unit and placement of the packing material for possible future return.
2. Record the number of hours on the hour meter underneath the unit.
3. Verify that the air filter is in place in the handle cavity.
4. Plug the unit into an electrical outlet, turn the unit ON, and check the audible and visible alerts.
5. Set the flow to 3 LPM in continuous flow mode and let the unit run for at least 20 minutes.
6. Use an oxygen analyzer to check the concentration.

**NOTE**—If the unit fails to operate properly, oxygen concentration is not within specification, or external/internal damage is found, contact DeVilbiss for instructions.

7. Instruct the user on the safe operation of the portable oxygen system; review the Important Safeguards and observe all Warnings and Cautions on the product and in the instruction guide.
8. Leave a copy of this instruction guide with the user.

**NOTE**—DeVilbiss recommends leaving a reserve oxygen supply with the patient when setting up the iGo, and instructing the patient to always keep reserve oxygen on hand.

## IEC SYMBOLS AND SYMBOL DEFINITIONS

	Attention - Consult Instruction Guide		WEEE Taiwan		Service Required
	Danger-No Smoking or Naked Flame		Recyclable Li-ion Battery		Flow Indicator
	Electric Shock Hazard		RBRC Recycle		Mode Select (Continuous Flow/PulseDose) Button
	Alternating Current		Power Button		Increase Flow Setting
	Direct Current (DC Power)		No Breath Detected in PD Mode with audible alert		Decrease Flow Setting
	Type BF Equipment		External Power Present Indicator (solid light). Power Fail Alarm (flashing light)		Rechargeable Battery Status Symbol
	Drip Proof Equipment IPX1		Normal Oxygen		Low Oxygen
IPX0	Non-protected (ordinary equipment)		No Naked Flames		Use no oil or grease
	Follow instructions for use		The device contains electrical and/or electronic equipment that must be recycled per EC Directive 2002/96/EC - Waste Electrical and Electronic Equipment (WEEE)		

## INDICATIONS FOR USE

The Model 306 DeVilbiss iGo Portable Oxygen Concentrator System is indicated for the administration of supplemental oxygen. The device is not intended for life support, nor does it provide any patient monitoring capabilities.

## IMPORTANT PARTS (Page 2)

### DeVilbiss iGo Portable Oxygen System (Fig. A-E)

- |   |  |                          |
|---|--|--------------------------|
| 1. Handle (one on top rear/two on bottom-sides)                                       | 6. Communication Port - This port allows service personnel to diagnose and monitor iGo performance. It is not for patient use. | 12. Slot in Battery Bay  |
| 2. Control Panel - Refer to iGo Control Panel below                                   | 7. Air Filter  | 13. Rechargeable Battery |
| 3. Power Button - Press and hold the Power On/Off Button to turn your unit on or off. | 8. Rating Label (on bottom)  | 14. Battery Tabs         |
| 4. Oxygen Outlet - oxygen is dispersed through this port.                             | 9. Exhaust Vents (on each side)  | 15. Battery Latch        |
| 5. Power Input - Connect either AC or DC power.                                       | 10. Cart Connection  | 16. Battery Contacts     |
|   | 11. Battery Bay  | 17. AC Adapter           |
|   |  | 18. DC Adapter           |

### iGo Control Panel (Fig. 1)

1. Power Button - turns the system ON or OFF
2. No Breath Detected in PulseDose Mode Light -- When the iGo is in PulseDose mode and doesn't sense any breathing for 30 seconds, light flashes; audible alert will beep every 3 seconds when this activates. If a breath is detected during the alert, the alert condition is cleared. If a breath is not detected during the alert, the unit changes to Continuous Flow mode after 60 seconds of alerting. **NOTE**—Once the unit changes to Continuous Flow, use the Mode Select Button to change back to PulseDose.
3. External Power Present Light/Power Fail Alert
  - 3a. External Power Present Light – Light illuminates when the iGo system is connected to either AC or DC power.
  - 3b. Power Fail Alert – Audible Alert sounds in conjunction with flashing light for 15 minutes when Power Fail Alert activates. Pressing the Power Button stops the alert.
4. Oxygen Concentration Lights:
  - 4a. Green Normal Oxygen Light = Normal Operation, Acceptable Oxygen Level; illuminates when your iGo is operating properly.
  - 4b. Yellow Low Oxygen Light = Operating Below an Acceptable Oxygen Level; illuminates when there is a problem with your unit. Refer to Troubleshooting for instructions
  - 4c. Red Service Required Light = Abnormal Operation/Malfunction, Concentration Below an Acceptable Oxygen Level; illuminates with an audible alert when there is a problem with your unit. Switch to your reserve oxygen system. Refer to Troubleshooting and/or call your DeVilbiss provider for instructions. Do not attempt any other maintenance.
5. Mode Select Button and Flow Indicator Light
  - 5a. Use Mode Select Button to select either PulseDose or Continuous Flow.
  - 5b. Flow Indicator Light pulses with every breath when in PulseDose mode; illuminates continuously when in Continuous Flow mode
6. Green Flow Rate Setting Lights (1-6) and Flow Rate Setting Buttons
  - 6a. Your provider has set your prescribed flow rates for both PulseDose and Continuous Flow. Do not change these settings unless it is under the order of your physician.
  - 6b. Increase Flow Rate Setting Button and Decrease Flow Rate Setting Button – use buttons to increase or decrease your flow rate if a change is ordered by your physician.
7. Battery Status Gauge and Low Battery Alert – when a Battery is installed, this indicates the charge remaining in battery. All 6 lights illuminate Green when fully charged. As battery becomes depleted, the top lights will go out. When battery gets to lowest operating level, the lowest light will turn Yellow and one short audible alert will sound. The lights cycle when battery is being charged.

## ACCESSORIES

### WARNING

Certain oxygen accessories not specified for use with the iGo Portable Oxygen System may impair the performance. ONLY use recommended oxygen delivery accessories.

Humidifier Kit includes Remote Stand, Humidifier, and Elbow Adapter (only for use in Continuous Flow mode).....	306DS-627
Humidifier (200 ml Capacity) - 50/case (only for use in Continuous Flow mode).....	HUM16
Elbow Humidifier Adapter Kit.....	444-507
Cannula (disposable) - 50/case .....	CAN00
Cannula w/ 2.1 m (7 ft) Oxygen Tubing (disposable) - 50/case .....	CAN70
Oxygen Tubing Connector.....	TC002
Oxygen Tubing (disposable)	
- 2.1 m (7 ft) - 50/case.....	OST07
- 4.2 m (14 ft) - 50/case.....	OST15
- 7.5 m (25 ft) - 25/case.....	OST25
DeVilbiss Rechargeable Battery.....	306D-413
Rolling Carry Case.....	306DS-625
Detachable Wheeled Cart.....	306DS-626
Air Filter.....	306DS-611
DC Adapter.....	306DS-652
AC Adapter.....	306DS-651
AC Power Cords	
USA Power Cord.....	306DS-601
Continental Europe Power Cord.....	306DS-602
UK Power Cord.....	306DS-603
Australia Power Cord.....	306DS-604
China Power Cord.....	306DS-605

## SETTING UP YOUR IGO OXYGEN SYSTEM

### DANGER

Keep the iGo at least 5 feet (1.6 m) from hot, sparking objects or open sources of flame. Do not locate near flammable materials or in the direct path of any heat source, such as a heat register or car heater.

### WARNING

Before moving or repositioning the iGo, always disconnect the power cord. Failure to do so may result in damage to the unit or personal injury.

1. Do not operate the iGo Portable Oxygen System without first reading the Important Safeguards; observe all Warnings and Cautions on the product and in the instruction guide.
2. Position the iGo so that alerts can be heard.
3. Do not use in a closet or any small, enclosed space.
4. Route oxygen tubing such that it does not kink and is not subject to occlusion.
5. If this is a new unit or you have installed a New Battery, refer to Initial Battery Operation section on page EN-8.
6. Position your unit near an electrical outlet at least 6 inches (16 cm) from walls, draperies, or any other objects that might prevent the proper flow of air in and out of your iGo. The iGo should be located so as to avoid pollutants or fumes, and placed in a well-ventilated place so that the air inlet and exhaust are not blocked. Do not cover unit with a blanket, towel, quilt, or other covering, as the unit may overheat.

**NOTE**– Do not connect the iGo to an extension cord or to an electrical outlet controlled by a wall switch. No other appliances should be plugged into the wall outlet.

### Before Operating Your iGo

1. Always check to see that the Air Filter is clean. Proper cleaning of this filter is discussed in the Caring for Your iGo System section.
2. Check to be sure that the Exhaust Vents are not blocked.
3. Attach the appropriate accessories to the oxygen outlet.

#### Oxygen Tubing Connection:

- a. Attach the tubing to the oxygen outlet. Make sure it is securely attached.

#### Oxygen Tubing Connection with Humidification:

**NOTE**–A humidifier can be used in Continuous Flow mode ONLY. Do not use a humidifier when in PulseDose mode:

- a. Attach the elbow humidifier adapter directly to the humidifier bottle. Attach oxygen tubing (50' max) to the to the elbow humidifier adapter and oxygen outlet. Make sure it is securely tightened. Place the humidifier bottle on the humidifier stand and secure the stand on a sturdy, flat surface near the patient where it will be safe and will not be knocked over. The humidifier bottle must remain upright to prevent water from entering the cannula.
4. Your physician has prescribed a nasal cannula. In most cases, they are already attached to the oxygen tubing. If not, follow the manufacturer's instructions for attachment. Attach the cannula tubing (7' max) directly to the humidifier bottle.

**NOTE**–Use only standard nasal cannula when in PulseDose mode; do not use pediatric (low-flow) nasal cannula with PulseDose delivery. Any nasal cannula can be used with Continuous Flow mode.

5. For portable use, ensure fully charged battery is installed and necessary accessories (e.g. AC or DC cords/adapters) are packed.

### Selecting the iGo Power Source

The iGo is a lightweight, portable oxygen concentrator capable of being operated directly from three different power sources: (1) AC Power (2) DC Power, or (3) Rechargeable Battery.

## WARNING

Do not expose any power cords/adapters to water or other liquid spills or drips. Electric shock or serious injury may result.

Improper use of the power cords, plugs, and/or adapters can cause a burn, fire, or electric shock hazard. Do not use any power cord/adapter that is damaged.

Do not operate device or accessories in standing water and do not submerge or expose to water. The iGo enclosure does not provide protection against the harmful effects of liquid ingress. Electric shock or damage to the unit may result.

## AC Operation

The iGo includes a universal AC Adapter which attaches to the AC Power Cord for use at home or where standard AC power is available. To use AC power:

1. Connect the AC Adapter by aligning the arrow on the plug locking ring with the white dot on the receptacle of the unit. Push until the locking ring twists slightly counterclockwise, then snaps back into alignment with the dot on the receptacle. To disconnect: grasp the plug, twist counterclockwise, and pull. When properly connected, a green indicator light on the AC Adapter will light and the External Power Present light will appear on the control panel.
2. Connect the AC Power Cord to the AC Adapter and to a grounded power outlet. Do not connect the iGo to an extension cord or to an electrical outlet controlled by a wall switch. No other appliances should be plugged into the wall outlet.

**NOTE**—Use with grounded, 3-pin receptacle. DO NOT remove ground pin from cord. Use only with DeVilbiss approved cords.

**NOTE**—The AC Power Cord used with the iGo must meet the requirements of the country where the product is used.

## DC Operation

Your iGo includes a DC Adapter that allows the system to operate from DC accessory power port outlets such as those found in motor vehicles.

1. Determine the Fuse rating in your motor vehicle; the rating must be 15 AMP or greater —consult the Operator's Manual for your vehicle or look at your fuse panel in the vehicle.
2. **Start your vehicle.** **NOTE**—DO NOT leave the iGo or DC Adapter plugged into the vehicle without the engine running or attempt to start the vehicle while the DC Adapter is connected to the vehicle. This may drain the vehicle's battery.
3. Insert the DC Adapter into the Power Input on the side of the iGo. Connect the adapter by aligning the arrow on the plug locking ring with the white dot on the receptacle of the unit. Push until the locking ring twists slightly counterclockwise, then snaps back into alignment with the dot on the receptacle. To disconnect: grasp the plug, twist counterclockwise, and pull.
4. Ensure the DC accessory power port is clean and a good connection can be made. Insert the other end of the DC Adapter into the vehicle's DC accessory power port. When properly connected and receiving power from the DC source, a green indicator light on the DC Adapter and the External Power Present light on the control panel will illuminate.
5. Secure the iGo and the DC Adapter in your vehicle and make sure the air inlet and exhaust vents are not blocked.

**NOTE**—The battery will not charge when connected to a DC accessory power port.

## Battery Operation

### WARNING

Electronics are static sensitive and may be an electric shock hazard. When the battery is removed, do not touch the contacts in the Battery Bay or on the battery. The communication port is also static sensitive and should not be touched.

The iGo can also be powered by a Rechargeable Battery. If the battery is installed and adequate power is available, the iGo will charge the battery any time AC power is present and the battery temperature is below a safe charging temperature. If external power is disconnected, the iGo will automatically switch over to the battery (if installed). When external AC power is restored, the iGo will accept power from the external source and charge the battery.

**Installing the Battery:** Insert the battery tabs into the slots in the Battery Bay and push the battery until it is secure and flush with the back of the system. When the battery is properly installed and the iGo is On, the Battery Status Gauge will appear on the Control Panel. (If you DO NOT have a Battery installed, the Status Gauge will not light up).

**Removing the Battery:** Push down on the Battery latch. The Battery will tilt so that you can grasp it for removal. **CAUTION**—When the battery is removed, the Communication Port is exposed. Do not attach any cables to this port; it is for service only. The Battery Contacts inside the bay and on the battery are also exposed and should not be touched.

**Battery Capacity:** The capacity of the Battery is lit up on the control panel. A variety of factors, such as age of battery, flow rate, and PulseDose or Continuous Flow Mode operation, determine the duration of operating time. The following table provides estimates of amount of time that a new, fully charged iGo Battery will operate.

### Typical New Battery Operation Time

Setting	Continuous Flow	PulseDose (20 BPM)
1.0	4.0 hours	5.4 hours
2.0	2.4 hours	4.7 hours
3.0	1.6 hours	4.0 hours
4.0	—	3.5 hours
5.0	—	3.2 hours
6.0	—	3.0 hours

**NOTE**—Be sure to check the battery charge level before travel; battery will discharge over time.

### WARNING

Do not short circuit the Battery's metal contacts with metallic objects such as keys or coins. It may cause sparks or excessive heat.

Do not tamper with, disassemble, puncture, or crush the Battery. There are no serviceable parts inside the Battery. Do not open. Battery electrolytes may be toxic if swallowed and can be harmful to skin and eyes. Keep the Battery away from children.

Exposing the Battery to water or other liquids may cause personal injury.

Replace the Battery with only approved DeVilbiss Rechargeable Battery. The iGo system can only work with a DeVilbiss Battery. Use of a damaged battery or a non-approved Battery may damage the unit, present a risk of fire or explosion, cause personal injury, and will void the warranty.

The Battery used in this device may present a risk of fire or chemical burn if mistreated. DO NOT disassemble, incinerate, or heat above 140°F (60°C) such as in a vehicle parked in the sun or on a hot day.

Return your Battery to your provider for proper disposal.



**CAUTION**—DO NOT drop the Battery or expose it to mechanical shock.

**CAUTION**—Only use the Battery for its intended purpose.

**NOTE**—Operating time will degrade with Battery use and age.

**NOTE**—Store your Battery in a cool, dry location when not in use. This will help to assure the longevity of your Battery.

**NOTE**—Charging the Battery below 50°F (10°C) or above 104°F (40°C) may degrade the performance. The Battery will not charge above 45°C.

### Initial Battery Operation

The new battery packaged with your iGo Portable Oxygen System is not fully charged. Before using your iGo for the first time, you must install and fully discharge then fully charge the battery.

1. Using battery power only, operate the iGo until the battery is fully drained. The unit will turn off and the power failure alarm will sound.
2. Connect the AC Power Cord and plug in to completely charge the battery. This may require up to 4.5 hours of uninterrupted charging.

In the event of a power interruption, the iGo Portable Oxygen System will automatically switch to the battery operation if installed. When AC power is restored, the battery will automatically start recharging. If the battery is not present during a power interruption, the Power Fail alert will activate and the iGo will stop operation. When power is restored, unit will resume oxygen production unless the Power Button was pressed to stop the Power Fail Alert.

### Typical Battery Recharge Time

The typical time to recharge your battery from a fully discharged condition is 2.0 hours to 4.5 hours dependent upon the flow setting. If the Battery is too warm, charging will not begin until it sufficiently cools. Extreme temperature (high or low) may extend charge time.

## OPERATING YOUR IGO

### WARNING

**Do not leave iGo running when not in use. Do not leave cannula unattended while unit is delivering oxygen. High concentrations of oxygen can cause rapid burning. Keep the equipment in a well-ventilated area.**

1. Check to see if the air filter is in place before using. If the air filter needs to be cleaned, wash with soapy water and allow to dry before using. If necessary, replace with a new air filter.
2. Plug unit into AC Power, DC Power, or make sure there is a charged Battery installed.  
**NOTE**—Every time a button is pressed or when a change to the power source occurs, the iGo will give a short audible chirp.
3. Connect the tubing to the oxygen outlet and the cannula.

### DANGER

**If tubing becomes disconnected during operation, iGo does not alert. Check flow at the cannula to verify oxygen delivery.**

4. Attach a standard nasal cannula to the oxygen outlet and to your nose and face. Breathe normally through the cannula.  
**CAUTION**—To ensure there is adequate flow to deliver oxygen, the length of the tubing must not exceed 50 feet (15.2m) when using Continuous Flow Mode, and must not exceed 35 feet (10.5m) when operating in PulseDose Mode for adequate breath detection.
5. Press and hold the Power Button to turn your iGo On. When the unit is turned On, all the lights on the control panel will illuminate briefly and audible alert will briefly activate.
  - a. When using External Power:
    - 1) In PulseDose mode: After a few seconds, the External Power, Normal Oxygen, and Flow Rate lights will remain lit. The Flow Indicator Light will pulse with each breath. If a battery is installed, the Battery Status Lights will either illuminate indicating battery charge level or cycle indicating battery is charging.
    - 2) In Continuous Flow mode: After a few seconds, the External Power, Normal Oxygen, Flow Indicator, and Flow Rate lights will remain lit. If a battery is installed, the Battery Status Lights will either illuminate indicating battery charge level or cycle indicating battery is charging.
  - b. When using Battery Power:
    - 1) In PulseDose mode: After a few seconds, the Normal Oxygen and Flow Rate lights will remain lit. The Battery Status Gauge Lights will also be lit indicating battery charge level. The Flow Indicator Light will pulse with each breath.
    - 2) In Continuous Flow mode: After a few seconds, the Normal Oxygen, Flow Rate, and Flow Indicator lights will remain lit. The Battery Status Gauge Lights will also be lit indicating battery charge level.  
**NOTE**—The DeVilbiss iGo has an oxygen sensing device (OSD®) to monitor oxygen purity once the oxygen stabilization process is complete (after approximately the first 20 minutes of operation). Once stabilized, the OSD monitors the oxygen purity and will alert if purity falls below an acceptable level.
6. To change your Delivery Mode, press the Mode Select button. The iGo will come on at the last mode and flow setting used.
  - a. Continuous Flow Operation - When operating in Continuous Flow Mode, a continuous supply of oxygen will flow through your tubing and nasal cannula.
  - b. PulseDose Operation - When operating in PulseDose mode, an alert will beep after 30 seconds if a breath is not detected. If another 60 seconds elapses and no breath is detected, the unit will switch to Continuous Flow at the last Continuous Flow setting used.  
**NOTE**—PulseDose dramatically extends the use time of the iGo Portable Oxygen System offering increased mobility with improved comfort and increased efficiency. Many users find PulseDose oxygen delivery more comfortable than continuous flow delivery systems.

### WARNING

**PulseDose Flow settings should be determined for each patient individually. Settings from Continuous Flow applications may not be applicable to PulseDose Mode.**

**As with conserving devices, the iGo may not be able to detect some respiratory efforts in PulseDose mode.**

**CAUTION**—Do not use with other equipment (i.e. humidifier, nebulizer, etc.) when in PulseDose delivery mode. The iGo will not detect a breath and will default to Continuous Flow.

**NOTE**—A pediatric or low-flow cannula should not be used in PulseDose delivery mode. The reduced diameter of the cannula causes too much back pressure and will affect the oxygen volume delivered.

**NOTE**—PulseDose delivers oxygen in a very short “puff.” It does not deliver oxygen continuously. The length of time that PulseDose delivers oxygen will not vary from breath to breath. The time is set in correlation to the patient’s prescription setting.

**NOTE**–You will get longer operating time on your Battery if you operate your iGo in PulseDose mode.

7. Check the Flow Rate to make sure it is set to your prescription setting. If adjustment is needed, use the Flow Rate Setting buttons to adjust the flow rate to the setting prescribed by your physician. **NOTE**– Your DeVilbiss provider may have set the flow so that it cannot be adjusted.

## WARNING

Under certain circumstances, oxygen therapy can be hazardous. Seeking medical advice before using an oxygen concentrator is advisable. It is very important to follow your oxygen prescription. Do not increase or decrease the flow of oxygen - consult your physician.

8. When you have finished using the iGo, press and hold the Power Button to turn Off. Store the iGo in a cool, dry location when not in use.

## TRAVEL

The iGo has two options for portability; both are for use on pedestrian surfaces:

### Rolling Carry Case

1. Place the iGo in the carry case.
2. The carry case has an opening for the cannula and one for external power connections. It also has several screened openings for airflow. Never block the air openings. Do not use a carry case other than one approved by DeVilbiss.
3. To adjust the handle height either pull up on the handle and/or press the button and push down on the handle.

**CAUTION**–The iGo should be taken as a carry-on item if traveling by air. If you are checking the iGo as luggage, it must be packed in a protective case. The Rolling Carry Case does not provide adequate protection if checking the iGo.

### Detachable Wheeled Cart

1. Align the locator holes on the bottom of the unit to the tabs on the cart.
2. Align the screw to the insert on the back of the iGo and hand-tighten the knob on the cart.
3. Push the button on the cart handle to adjust the height.

**CAUTION**– When transporting the iGo, care should be taken to avoid excessive shock.

**NOTE**– Before starting a trip, check with your DeVilbiss provider for options (e.g. extra battery/AC Cord for use at destination). Refer to Accessories for appropriate cord.

## RESERVE OXYGEN SYSTEM

As a precaution, your DeVilbiss provider may supply you with a reserve oxygen system. If your unit loses electrical power or fails to operate correctly, the Patient Alert System will sound to signal you to switch to your reserve oxygen system (if provided). Contact your DeVilbiss provider.

## WARNING

Availability of an alternate source of oxygen is recommended in case of power outage or mechanical failure. Consult your physician for the type of back-up system required. Do not ignore alerts.

## TROUBLESHOOTING

The following troubleshooting chart will help you analyze and correct minor iGo malfunctions. If the suggested procedures do not help, switch to your reserve oxygen system and call your DeVilbiss homecare provider. Do not attempt any other maintenance.

## WARNING

To avoid electric shock hazard, do not remove the covers. There are no user serviceable internal components. The covers should only be removed by a qualified DeVilbiss provider/DeVilbiss homecare technician.

SYMPTOM	POSSIBLE CAUSE	REMEDY
Unit does not operate. No lights are illuminated and nothing happens when power button is pressed and held for 1 second.	1. Power button was not held.	1. Press Power button and hold for 1 second.
	2. No External Power and no charged battery installed.	2. Plug into external power or install charged battery.
	3. Unit malfunction.	3. Contact your DeVilbiss provider.
Unit does not operate. External Power Light flashes with audible alert. Power Fail Alert is activated.	1. AC power cord not properly inserted into wall outlet or DC adapter not attached.	1. Check power cord connection at the wall outlet and adapter connection to unit.
	2. Charged battery not installed or defective battery.	2. Install charged battery or contact your provider for a replacement battery.
	3. No power at wall outlet.	3. Check your home circuit breaker and reset if necessary. Use a different wall outlet if the situation occurs again.
	4. Faulty AC Adapter.	4. Contact your DeVilbiss provider.
	5. Faulty DC accessory power port outlet.	5. Check automotive fuse.
	6. Faulty DC Adapter.	6. Contact your DeVilbiss provider.
No Breath Detected light flashing and audible alert sounding (PulseDose Mode only). Unit set up for PulseDose mode but changed to Continuous Flow because no breath was detected.	1. Obstructed cannula or oxygen tubing.	1. Detach cannula. If proper flow is restored, clean or replace if necessary. Disconnect the oxygen tubing at the oxygen outlet. If proper flow is restored, check oxygen tubing for obstructions or kinks. Replace if necessary.
	2. Cannula is not adjusted properly.	2. Check all cannula connections to make sure they are tight, and adjust the cannula to fit comfortably in your nose. Ensure tubing is not kinked.
	3. Tubing/cannula too long.	3. Replace with shorter tubing/cannula.
	4. Humidifier attached.	4. Remove humidifier.
	5. Low flow cannula being used.	5. Replace with standard cannula.
	6. Atmospheric Pressure Port obstructed.	6. Remove obstruction.
	7. Patient not candidate for PulseDose delivery. <b>NOTE</b> –Unit will automatically change to CF Mode if this condition is not corrected.	7. Use CF delivery for patients that fail to trigger equipment (e.g. mouth breather with closed soft palate.)

SYMPTOM	POSSIBLE CAUSE	REMEDY
Cannot adjust/change the flow rate.	1. Flow rate has been locked by your provider.	1. Contact your DeVilbiss provider.
	2. Unit malfunction.	2. Contact your DeVilbiss provider.
Yellow Low Oxygen light is illuminated. <b>OR</b> Red Service Required light is illuminated with audible alert. External Power and/or Battery Power lights illuminated. Unit is operating.	1. Air filter is blocked.	1. Check the air filter. If the filter is dirty, wash it following the cleaning instructions.
	2. Exhaust is blocked.	2. Check the exhaust area; make sure there is nothing restricting the unit exhaust.
Red Service Required light is illuminated. External Power and/or Battery Power lights illuminated. Audible alert is sounding. Unit does not operate.	1. Air filter is blocked.	1. Check the air filter. If the filter is dirty, wash it following the cleaning instructions.
	2. Exhaust is blocked.	2. Check the exhaust area; make sure there is nothing restricting the unit exhaust.
	3. Unit is overheated.	3a. Allow unit to cool and try again. 3b. Move unit to cooler location.
Power Fail Alert activates (External Power light flashes and audible alert sounds).	1. Battery completely discharged.	1. Recharge battery.
	2. Lost external power without battery installed.	2. Install battery or plug into external power.
Red Service required light is flashing. Flow Indicator light is flashing. Audible Alert is sounding. Unit is operating.	1. Blocked or defective cannula or oxygen tubing	1. Detach cannula. If proper flow is restored, clean or replace if necessary. Disconnect the oxygen tubing at the oxygen outlet. If proper flow is restored, check oxygen tubing for obstructions or kinks. Replace if necessary.
Unit does not operate when using with charged battery. Power Fail alarm activates.	1. Battery is overheating.	1. Allow battery to cool.
DC Adapter is attached. Unit runs from Battery or does not run. The External Power Present Light not illuminated.	1. Poor connection to DC power source.	1. Ensure the DC accessory outlet is clean and a good connection can be made. Insert the other end of the DC Adapter into the vehicle's DC accessory outlet.
	2. Vehicle power source (vehicle accessory connector) dropped too low for the DC Adapter.	2. If the vehicle power source drops too low for the DC Adapter, the iGo will revert to Battery operation (if present) or will cease operation until power is restored.
	3. Fuse in vehicle is blown.	3. Check the fuse and replace if necessary.
Lowest Battery Status Light is Yellow. Unit beeps once.	1. Battery needs to be charged.	1. Plug unit into AC power or replace discharged battery with charged battery.
		2. Plug unit into DC accessory outlet to operate unit (battery will not recharge on DC power).
Battery Status Lights never indicate fully charged.	1. Battery needs to be conditioned.	1. Fully discharge battery then recharge.
	2. Defective battery.	2. Contact your DeVilbiss provider.
Yellow Battery Status light is flashing.	1. Unit is equipped with built-in battery test and the battery pack is being checked.	1. If light flashes longer than 5 minutes, battery is defective. Contact your DeVilbiss provider for a replacement.
Audible Alert sounds intermittently when operating from DC Adapter.	1. Vehicle not running.	1. Start vehicle.
	2. Poor connection to DC power source.	2. Ensure the DC accessory power port outlet is clean and a good connection can be made. Insert the DC Adapter into the vehicle's DC accessory outlet.
	3. Vehicle electrical system overloaded or defective.	3. Have a qualified auto technician check electrical system while iGo is attached.
Short Battery Run Time.	1. Battery needs to be reconditioned.	1. Perform a complete discharge and then a 100% charge of the battery.
	2. Air filter is blocked.	2. Check the air filter. If the filter is dirty, wash it following the cleaning instructions.
	3. Exhaust is blocked.	3. Check the exhaust area; make sure there is nothing restricting the unit exhaust.
	4. Intake filter silencer is blocked.	4. Replace the intake silencer/filter.
If any other problems occur with your iGo.		1. Turn your unit Off and switch to your reserve oxygen system. Contact your DeVilbiss provider immediately.

## CARING FOR YOUR DEVILBISS IGO PORTABLE OXYGEN SYSTEM

### WARNING

Before attempting any cleaning procedure, turn the unit Off and disconnect from AC or DC power.

Do not use lubricants, oils, or grease.

### Air Filter

The air filter should be cleaned at least once a week. To clean, follow these steps:

1. Remove the air filter.
2. Wash in a solution of warm water and dishwashing detergent.
3. Rinse thoroughly with warm tap water and towel dry. The filter should be completely dry before reinstalling.

**CAUTION-** To prevent product damage, do not attempt to operate the unit without the air filter or while the filter is still damp.

**NOTE-** Device has an internal intake filter that must be inspected by a qualified provider/technician every 3 years.

## AC Adapter and Power Cord/DC Adapter

The adapters and power cords should be cleaned as needed. To clean, follow these steps:

1. Disconnect cords from the iGo before cleaning.
2. Clean the cords by using a damp cloth with a mild household cleaner and wipe dry.

## Cannula and Tubing

Clean and replace the cannula and tubing as instructed by your DeVilbiss provider.

## Exterior Covers and DeVilbiss Rechargeable Battery

### WARNING

To avoid electric shock, do not remove the iGo covers. The covers should only be removed by a qualified DeVilbiss provider. Do not apply liquid directly to the covers or utilize any petroleum-based solvents or cleaning agents.

Use of harsh chemicals (including alcohol) is not recommended. If bactericidal cleaning is required, a non-alcohol based product should be used to avoid inadvertent damage.

The exterior covers and rechargeable battery should be cleaned as needed. To clean, follow these steps:

1. The battery should remain installed and be wiped clean with the covers. If battery is removed, wipe the battery bay and battery with a Dry Cloth only.
2. Clean the iGo exterior covers by using a damp cloth with a mild household cleaner and wipe it dry.

## Humidifier (reusable bottle)

If your physician has prescribed humidification for use during continuous flow mode, clean your humidifier bottle daily. Follow the instructions supplied by the manufacturer. If no cleaning instructions were supplied, follow these steps:

1. Wash the humidifier in a solution of hot water and dishwashing detergent.
2. Soak the humidifier in a solution of one part white vinegar to three parts hot water for 30 minutes. This solution acts as a germicidal agent.
3. Rinse thoroughly with hot tap water and refill with distilled water for use. Do not overfill.

## Rolling Carry Case and Detachable Wheeled Cart

The carry case and/or cart should be cleaned as needed. To clean, follow these steps:

1. Remove the iGo from the carry case or cart before cleaning.
2. Clean the case or cart by using a damp cloth with a mild household cleaner and wipe dry.

## Battery Storage

Your Battery should be stored in a cool, dry location when not in use.

## Battery Disposal / Disposal of Equipment and Accessories

Your Battery is rechargeable and can be recycled. Follow local governing ordinances and recycling plans regarding disposal of device components. Do not dispose of the rechargeable Battery. Contact your DeVilbiss provider before disposal of battery or any iGo components.

## SPECIFICATIONS

Dimensions (H x W x D).....	15 inches x 11 inches x 8 inches (38.0 cm x 28.0 cm x 20.0 cm)
Weight .....	19 pounds (8.6 kg) with Battery 15.5 pounds (7.0 kg) without Battery
Flow Rate Settings .....	1 to 6 in PulseDose Mode 1 to 3 LPM in Continuous Flow Mode
Maximum Recommended Continuous Flow (@ nominal outlet pressures of 0 and 7 kPa) .....	3 LPM
Maximum Breathing Rate (PulseDose mode only) .....	40 BPM @ settings 1-4 37 BPM @ setting 5 31 BPM @ setting 6
Oxygen Concentration .....	91% ± 3% for all flow settings
Maximum System Pressure .....	15 psig (103.5 kPa)
Oxygen Outlet Pressure .....	5.0 ± 1.0 psig (34.5 ± 7 kPa)
Operating Temperature.....	41°F to 104°F (5°C to 40°C)
Operating Humidity.....	10% - 95% at 82.4°F (28°C) dew point
Transportation and Storage Temperature .....	-4°F to +140°F (-20°C to +60°C)
Transportation and Storage Humidity.....	10% to 95% non-condensing
Transportation and Storage Atmospheric Pressure (at nominal temperature and humidity) (Tested at ~933 hPa) .....	640 hPa - 1010 hPa
Altitude (Tested at ~933 hPa).....	0 -13,123 feet (0 - 4,000 meters)
Nominal Sound Level .....	40 dBA at 3 in PulseDose Delivery Mode
Maximum Sound Level in Battery Mode (from front) @ 3 LPM continuous flow .....	48 dBA
Maximum Sound Level as test per ISO 8359 .....	55 dBA
Pressure Relief Mechanism .....	20 psi ±20% (138 kPa ± 20%)
OSD Set Points .....	≥ 84% - Normal Light (green) 75-85% - Low O <sub>2</sub> Light (yellow) < 75% - Service Required Light (red) and Audible Alert

### Electrical Power:

DeVilbiss Rechargeable Battery (Lithium Ion).....	8.8 Amp Hrs
AC Adapter Input Voltage Range .....	100-250Vac, 50/60 Hz
DC Adapter .....	12 Volt Negative Ground Vehicles

**Adapter Manufacturer Info:**

AC Adapter .....Jerome Industries Model # WSX828M, Autec Model # DT-EM250-2805  
 DC Adapter .....EDAC, Model ED1010E

**Audible Alerts:**

- Power Fail
- Low Battery
- Low Oxygen Output
- High Flow/Low Flow
- No Breath Detected in PulseDose Mode
- High Temperature
- Unit Malfunction

Device Classification .....Class 1, Type BF Applied Part, IPX1 (Battery Mode Only), IPX0 (AC and DC Input Mode)

**CAUTION**—When moving the iGo from an extreme environment, allow time for your iGo to acclimate to the recommended operating environment. Operating your iGo outside the recommended operating environment may impact performance, cause damage, and will void the warranty.

Specifications subject to change without notice.

DeVilbiss will make available on request circuit diagrams, parts lists, etc.

**DEVILBISS GUIDANCE AND MANUFACTURER'S DECLARATION****WARNING**

Medical Electrical Equipment needs special precautions regarding EMC and needs to be installed and put into service according to the Electromagnetic Compatibility [EMC] information provided in the accompanying documents.

Portable and Mobile RF Communications Equipment can affect Medical Electrical Equipment.

The equipment or system should not be used adjacent to or stacked with other equipment and that if adjacent or stacked use is necessary, the equipment or system should be observed to verify normal operation in the configuration in which it will be used.

**NOTE**— The EMC tables and other guidelines provide information to the customer or user that is essential in determining the suitability of the Equipment or System for the Electromagnetic Environment of use, and in managing the Electromagnetic Environment of use to permit the Equipment or System to perform its intended use without disturbing other Equipment and Systems or non-medical electrical equipment.

**Guidance and Manufacturer's Declaration – Electromagnetic Emissions**

This device is intended for use in the electromagnetic environment specified below. The customer or the user of this device should assure that it is used in such an environment.

Emissions Test	Compliance	Electromagnetic Environment – Guidance
RF Emissions CISPR 11	Group 1	This device uses RF energy only for its internal function. Therefore, its RF emissions are very low and are not likely to cause any interference in nearby electronic equipment.
RF Emissions CISPR 11	Class B	This device is suitable for use in all establishments including domestic and those directly connected to the public low-voltage power supply network that supplies buildings used for domestic purposes.
Harmonic emissions IEC 61000-3-2	Class B	
Voltage fluctuations / flicker emissions	Complies	

**Guidance and Manufacturer's Declaration – Electromagnetic Immunity**

This device is intended for use in the electromagnetic environment specified below. The customer or the user of this device should assure that it is used in such an environment.

Immunity Test	IEC 60601 Test Level	Compliance Level	Electromagnetic Environment - Guidance
Electrostatic discharge (ESD) IEC 61000-4-2	±6kV contact ±8kV air	Complies	Floors should be wood, concrete, or ceramic tile. If floors are covered with synthetic material, the relative humidity should be at least 30%
Radiated RF IEC 61000-4-3	3 V/m 80MHz to 2.7GHz	Complies	Field strengths outside the shielded location from fixed RF transmitters, as determined by an electromagnetic site survey, should be less than 3 V/m. Interference may occur in the vicinity of equipment marked with the following symbol: 
Conducted RF IEC 61000-4-6	3 Vrms 150kHz to 80MHz	Complies	
Electrical fast transient IEC 61000-4-4	±2kV power line ±1kV I/O lines	Complies	Mains power quality should be that of a typical commercial or hospital environment.
Surge IEC 61000-4-5	±1kV differential ±2kV common	Complies	
Power frequency magnetic field IEC 61000-4-8	3 A/m	Complies	Power frequency magnetic fields should be at levels characteristic of a typical location in a typical commercial or hospital environment.
Voltage dips, short interrupts and voltage variations on power supply input lines IEC 61000-4-11	>95% dip 0.5 cycle 60% dip 5 cycles 70% dip 25 cycles 95% dip 5 secs.	Complies	Mains power quality should be that of a typical commercial or hospital environment. If the user of this device requires continued operation during power mains interruptions, it is recommended that the device be powered from an uninterruptible power supply or battery.



**DeVilbiss Healthcare LLC**  
100 DeVilbiss Drive  
Somerset, PA 15501-2125  
USA  
800-338-1988 • 814-443-4881

**DeVilbiss Healthcare Ltd**  
Unit 3, Bloomfield Park  
Bloomfield Road  
Tipton, West Midlands, DY4 9AP  
UNITED KINGDOM  
+44 (0) 121 521 3140

**DeVilbiss Healthcare Pty. Limited**  
15 Carrington Road, Unit 5  
Castle Hill NSW 2154  
AUSTRALIA  
+61-2-9899-3144

**DeVilbiss Healthcare SAS**  
13/17, Rue Joseph Priestley  
37100 Tours  
FRANCE  
+33 (0) 2 47 42 99 42



**DeVilbiss Healthcare GmbH**  
Kamenzer Straße 3  
68309 Mannheim  
GERMANY  
+49-621-178-98-230

DeVilbiss Healthcare LLC • 100 DeVilbiss Drive • Somerset, PA 15501 • USA  
800-338-1988 • 814-443-4881 • [www.DeVilbissHealthcare.com](http://www.DeVilbissHealthcare.com)

DeVilbiss®, PulseDose®, DeVilbiss iGo® and OSD® are registered trademarks of DeVilbiss Healthcare.

© 2012 DeVilbiss Healthcare LLC. 06.12 All Rights Reserved.

A-306-1 Rev. C