

Fabrication of a Boomerang Using Computational Tools to Develop Engineering Competences

Alejandro Guajardo-Cuñlar, Diego Cárdenas, and Manuel Lepe
Tecnologico de Monterrey, Escuela de Ingeniería y Ciencias, Guadalajara, Mexico
Email: alejandro.guajardo@tec.mx, diego.cardenas@tec.mx, manuel.lepe@tec.mx

Abstract— Engineering competences are characteristics, knowledge and skills that allow engineers to create in a challenging and dynamic environment. Higher education institutions must develop the competences that prepare engineering students to face modern society challenges. Here, it is presented a study case to develop engineering competences using low cost computational tools in combination with 3-d printing. A ludic activity is developed by undergrad students majoring Mechanical and Mechatronics Engineering. The design and fabrication of a boomerang by a group of students is analyzed and how they develop relevant competences during this process. The students are exposed to computational tools used during the project. First, databases for aerodynamic profiles are introduced. The databases used include curves of drag and lift coefficients performance for different attack angles. Students develop the understanding and the handling of those databases to create an aerodynamic profile for a boomerang. The computational tool used for numerical software is matlab and the g-code generation for 3-d printing used is ultimaker Cura. The methodology to design a boomerang using the tools mentioned is explained. Then, the development of engineering competences by the students during the activity is analyzed and discussed. It is observed that using a ludic educational activity in a short period using open access databases and numerical analysis computational tools is of great use to develop competences.

Index Terms—computational tools, design, 3-d printing, competence, educational innovation, higher education

I. INTRODUCTION

Product development is a task that engineers must perform in the most efficient manner. The design and mass production ramping process must be fast and cheap. The task cannot afford delays or bottlenecks during design and validation processes. Different computational and prototyping tools to reduce the cost and time to develop products are available. The challenge of engineers is to be able to handle those tools and to combine them in the proper way. One of the most traditional tool is the use of CAD/CAM. CAD/CAM allows the design and in some cases the modelling to ensure the proper functioning of the product. Tools that are more popular in academic and research environments for numerical computing such as matlab and

programming languages are also used. Matlab and high level programming languages are friendlier in latest releases. They are available now for more users with different background. Engineers and scientist can use them for product development. Open access databases with standard information such as aerodynamic profiles are also interesting. Most of the times the developer has to use them in an efficient fashion combined with the previous computational tools mentioned. One example quite popular is Airfoil tools to generate standard aerodynamic profiles [1]. Once all the previous tools are properly combined the possibility to visualize and to test at some level the product can be achieved with rapid prototyping. The most popular and cheap tool of rapid prototyping is 3-d printing. Engineers complete the loop for product design using all the tools described. The responsibility in the education of modern engineers is the development of competences that allow the engineer to combine these tools to create ideas. All the tools described previously are cheap and available to any standard engineering student across the globe. Typical course works in engineering majors spend great effort to train the student in the use of these tools in a separate way. The integration of the tools in most cases is done during a typical Senior Project course in a complex level.

In this work, we explore the development of competences using computational tools to create a product. A quick project developed during one week that integrates all these tools to create a flying boomerang is used as a study case. Besides the integration of the tools, gamification as a competence developer is studied [2]. The manuscript follows the next structure. First, we explain the study case used as a competence developer and relate the case with gamification as an innovative education technique. Then, a brief explanation for each of the computational tools used is presented. The next section shows the results achieved by the students that perform the task. Finally, conclusions and recommendations observed during the study are given.

II. STUDY CASE: A LUDIC ACTIVITY TO DEVELOP THE COMPETENCE

A boomerang is an ancient flying tool used with different purposes [3] [4] [5]. Due to the geometry and aerodynamic profile of the blades, the flying orbit of a boomerang is fascinating. Boomerangs are used as a recreational objects, however the flying dynamics has

Manuscript received November 11, 2019; revised August 21, 2020.
corresponding author: alejandro.guajardo@tec.mx

also been widely investigated [6] [7] [8] [9] [10]. Used as recreational and ludic objects they are attractive to be used for educational purposes. Gamification uses ludic activities to achieve a goal. It is widely used in education and the use and results has been widely documented by different authors [11]. Gamification is used here as an educational tool to design and fabricate a boomerang. During this process, engineering competences are developed with the motivation of a ludic activity behind the educational and technical activities.

Tecnologico de Monterrey a higher education institution in Mexico aims to develop the required competences in their students to achieve success in the professional field. The institution uses different approaches to achieve the development of engineering competences. The institution proposes different approaches to achieve this goal. From novel curricula to challenges solved by students in different periods, Tecnologico de Monterrey has changed the traditional teaching methods. "Semana I" that translates as innovation week is one of the pilot programs to implement the new model. The activity duration is 40 hours as described in the name. The short time frame responds to the necessity of dynamic learning environments for young students. The students are native users of information and communications technologies; therefore, they feel more comfortable in fast activities where they can finalize real projects. It prepares them to real product development situations where the product design process is done in short periods. The study case presented here was developed during the event "Semana I" for the term fall 2019 at Tecnologico de Monterrey campus Guadalajara, Mexico. The goal of the activity is to develop transversals and disciplinary competences. The transversals competences aimed are collaborative work and solution to problems. The disciplinary competences developed are design, analysis and fabrication of products. The disciplinary competence is broad and to achieve the competence different skills are needed. For this reason, the activity is open to student of different majors that observe the competence. The majors accepted for the activity are Mechanical Engineering, Mechatronics Engineering, Industrial Engineering, and related fields. The activity was open to sophomores, juniors and seniors students. The only requirement was to have basic knowledge of physics from freshmen year. The objective of the activity is to design, to model, to manufacture and to throw a boomerang. In the next sections, we describe each of the stages to achieve the objective using different computational tools and finally we describe the performance of the group.

III. COMPUTATIONAL TOOLS

A. Generating an Aerodynamic Profile

The first part of the activity provides a general understanding of aerodynamics, explanation of drag C_D and lift coefficients C_L and interpretation of curves of these coefficients as a function of design parameters such as angle of attack α . At this stage, the basic physics to understand the orbit of the boomerang and the flight is

taught. The student at the end of this introductory part should be able to choose a proper aerodynamic profile to start the design of the boomerang. An instructor conducts a session understanding a typical NACA profile including nomenclature, geometry, and analysis. The tool used for this purpose is Airfoil tools [1]. Airfoil tools is a tool for aerodynamic profiles that uses data from many databases. Students might choose any aerodynamic profile obtaining a normalized set of 2-d coordinates. The election is based with the gained knowledge of the physics behind the flight of the boomerang; however, considerations for the fabrication must be taken into account. Once the profile is chosen the normalized profile is exported and can be used to generate the geometry in either a CAD tool or using a computational numerical software such as matlab.

B. Numerical Computational Tool

Most engineering students are familiar with typical CAD commercial software. It is a challenge for the student to understand the computational geometry behind a surface or a solid generated with a CAD software. As a matter of an innovative tool, in this activity the solid to manufacture is expected to be built from a numerical generation of points done in matlab. The aim of using the tool is to expose the student to computational geometry. The use of the method allows the student to understand how solids can be generated out of coordinates. The first step to create a solid in matlab is to generate the plane of the aerodynamic profile. This can be done easily by exporting the normalized coordinates of the selected profile from airfoil tools in matlab. Fig. 1 shows the 2-d geometry of a typical NACA 2412 profile. At this stage, students compare the generation of a 2-d geometry using CAD versus using a numerical tool. The main challenge for them in this part of the process is to generate the third coordinate. Students at this stage are familiar programming loops and can handle the generation of the third coordinate with some effort. Advance students attending the activity use the commands from matlab to handle numerical arrays to generate it. Once they created the wing of their boomerang a subroutine is provided to generate a 3 or a 4 blade boomerang. It is beyond the scope of the project to create the final complex geometry of the boomerang in matlab from scratch. The subroutine provided allows to join the designed wing to a central cylinder generating the 3-d boomerang. Fig. 2 shows a typical 3-blade boomerang designed using this approach. Finally, a library available to generate a stl file out the coordinates is included in the script.

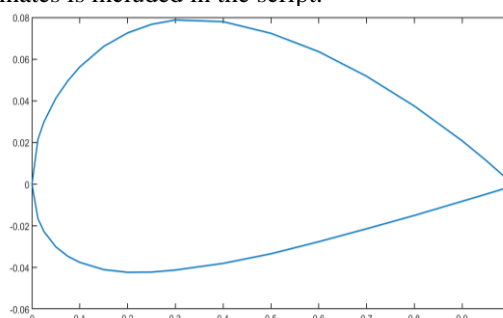

Figure 1. 2412 NACA profile generated in matlab exporting the coordinated from airfoil tools database

The computation with programming allows the generation of solids in an efficient manner. The student appreciates computational geometry and the manipulation of points to generate a final product, tracking all the coordinates all the time. Students can handle CAD softwares however, they do not have the knowledge how the points, surfaces or solids are generated. The method used here shows the student possibilities of a computational numerical software such as matlab. The same task can be achieved with any high level programming language, however here we used matlab taking into account that the background of the students is not computer science and the scope of the task is to develop a product easy cheap and in practical manner.

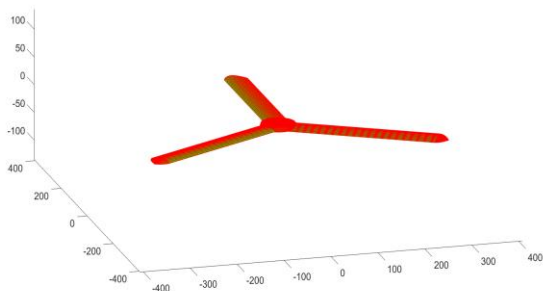

Figure 2. A 3-blade boomerang geometry generated in matlab.

C. 3-d Printing

The result of the design process is a stl file with the geometry. The boomerang has to be light, rigid and with structural strength. 3-d printing is a perfect cheap and simple manufacturing process candidate to products with such characteristics. The material selected for the final product is polylactide (PLA). PLA complies the requirements, is cheap and can be used in a typical standard additive manufacturing process. Low cost 3-d printers using PLA are available to students in an affordable expense. Commercial available 3-d printers already include the controller to print the geometry in g-code.

The challenge for the fabrication of the boomerang is the communication between the 3-d printer and the generated geometry. Here we use Cura [12]. Cura is a software for 3-d printing that communicates the stl file with the printer used. Once the 3-d geometry is generated as a stl file, Cura generates a printer specific g-code. The advantage of the software is that the user can scale the geometry to the dimensions of the printer and can control the filling percentage of material in the geometry. Aerodynamic profiles might be challenging for 3-d printing. The main challenge is the mechanical strength of the structure while the geometry is printed. The structure must have a rigid supporting skirt. This experience adds great value to the student to understand the 3-d printing process. Figs. 3 and 4 show the process of scaling of a typical boomerang design done by one of the group of students during the activity. Fig. 3 shows the original boomerang design with the original dimensions; the software does not scale the boomerang to fit the 3-d

printer used. The GUI allows to scale the geometry to fit the printer, the result is shown in Fig. 4. Once the scale is done, the geometry can be sliced and the g-code is generated. For entry-level users is of great advantage the scaling done by Cura. Designers can create their geometries without concerns regarding the dimensions of the 3-d printer.

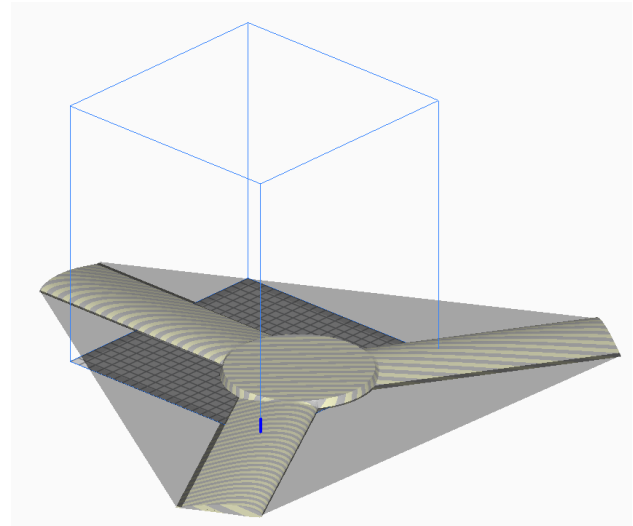

Figure 3. Typical scaling process for a boomerang to be printed. Here the geometry is not scaled to fit the dimensions of the printer.

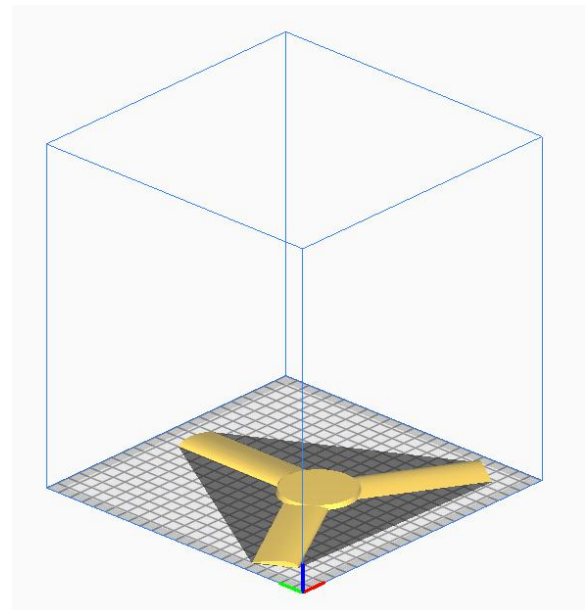

Figure 4. Typical scaling process for a boomerang to be printed. Cura allows to scale the geometry to fit the dimensions of the printer.

IV. RESULTS

Groups of students performed the activity. Each group fabricated at least one boomerang. At the end, all the groups competed to achieve the best orbit flight of the boomerang. In addition to the competition, the activity must be graded in a scale from 0 to 100 points. The points achieved have an impact of 5 % of the final grade of all the courses that the student is attending during the term.

The grading policy is also a motivation for the student to achieve the total score.

The activity was divided in 40 working hours. Table I shows the dedicated time for each activity and the learning technique used. The first activity was to understand the physics behind the flight of a boomerang, for these part traditional lectures about motion of rigid bodies, fluid mechanics and aerodynamics were provided. For the second activity, the group of students conducted independent research about aerodynamic airfoils and important parameters for the application. It was expected a proper aerodynamic profile selection after the previous knowledge about the physics of boomerangs and the investigated concepts. The class was supervised with an instructor with experience in aerodynamics to provide guidance in the selection. Table II shows the profiles selected by the students, C_L , C_D , and the ratio of them for an $\alpha = 0$. The designs use an aerodynamic profile with a ratio of lift vs drag of about 50. This shows that the designs is a result of a proper independent research and collaborative work to achieve an optimal profile. Students show good understanding of profiles selection with high lift and low drag. Here we can compare also the profile selected by the group that generated the flight with the best orbit flight evaluated (group 1). The criteria to determine the best orbit flight is based on the returning to starting point of the boomerang. Here the study shows that all the groups gained a good knowledge on how to choose an aerodynamic profile that fulfills the requirement using an open access database for aerodynamic profiles. This part of the activity truly confirm the development of design and use of computational tools based on physics law competence. The students shows the competence of design of products with understanding of physical laws.

TABLE I. ACTIVITY AGENDA WITH ESTIMATED TIME.

Activity	Estimated time (hours)	Learning technique
Understanding physics of boomerangs	8	Lecture
Understanding airfoil tools and selection of aerodynamic profile	8	Collaborative work, independent research
Design of boomerang using a computational numerical tool	8	Collaborative work, problem solving
3-d printing process	10	Collaborative work, discovery learning, problem solving
Documentation and final report	4	Collaborative work, independent research
Final recreational activity	2	Gamification
Total	40	

The third part to analyse consist on the use of matlab to generate the solid, in this part is observed that student still show a barrier in using programming to handle geometries. Out of the 6 groups, 5 groups used the provided tool, meanwhile one group was able to import the aerodynamic profile and to generate the solid in a CAD tool. Students were free to choose the generation of the solid as a problem solving learning technique. It is

evident that not all student are proactive using a numerical tool to generate a 3-d geometry. However, the use of a CAD tool in this case deprive students the understanding on how to generate a cloud of points out of a typical programming loops. Also this method is an introduction to computational mechanics. Computational mechanics requires the skill to generate geometries out of coordinates to simplify the understanding of nodes and meshes.

TABLE II. AIRFOIL PARAMETERS SELECTION FOR $\alpha=0^\circ$, BY DIFFERENT GROUP OF STUDENTS.

Group	Airfoil selection	CL	CD	CL/CD
1	USA 22	0.4	0.01	40
2	N-10	0.5	0.01	50
3	S1223	1.2	0.02	60
4	GOE 593	0.5	0.01	50
5	AG18	0.2	0.01	20
6	GOE 143	0.4	0.01	40

The next part reported is the 3-d impression. Here we observe the final link between design and fabrication. The main concern was the manipulation of fabrication parameters for low cost 3-d printers. The filling ratio of PLA is quite important, the results shows that this ratio is crucial to generate a proper flying orbit, flight dynamics are complex and the weight of the boomerang is essential for the flight. If it is too heavy it will represent difficulties to generate an initial rotation and if it is too light, it will not be sufficient to fly. Within the short time frame, students must deal with the situation based on trial and error. It is a discovery learning experience. Students must face the challenge of solving a real problem with time constrain developing the competence of problem solving, they do not have the complete knowledge to achieve this ratio and the impression process takes an average of 4 hours for the geometries proposed. The class were able to create geometries with appropriate weights that allows the boomerangs to produce orbits resulting from the precession. Figs. 5 and 6 show the printing process and the final product fabricated by one of the groups.

To document the process, the groups write a technical report with all the details for the product development process. Throwing the boomerangs is the final activity, during this session students exchange knowledge and experiences in a ludic fashion.

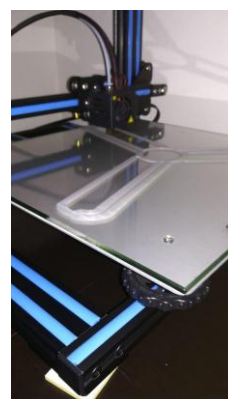

Figure 5. 3-d printing process of a boomerang for one of the teams.

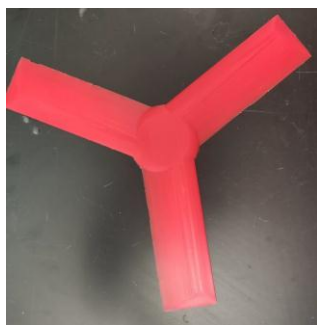

Figure 6. Final boomerang 3-d printed by one of the groups.

V. CONCLUSIONS

Highly qualified engineers must show a group of competences that allows them to create technologies and products to improve the human condition in all the fields. One of the main differences between these competences and the skills that were desired in an engineer few years ago is the openness to deal with different technologies and fields. It is quite important to observe an engineer that combines different fields of knowledge and technologies to create such technologies. The task of an academic institution is to educate engineers with competences that develop this profile. In this work, it is presented an activity developed in a short time frame that combines different fields of knowledge and different computational resources. We conclude that the use of low cost technologies, numerical software and open access databases are of great aid in the development of relevant competences.

It is of great value the use of ludic activities to develop these competences. The main conclusion is that current engineering students are fast and react to knowledge in a very dynamic way. We show a successful implementation of a task using not complex tools to satisfy this profile. The recommendation is to use low cost and wide available computational and manufacturing tools in short periods to develop competences in students. One of the main risks using available commercial tools is the constraint of licenses and computational software. Here we show how with simplicity of resources the possibility to combine them to create a product. One extra advantage is that student is aware and has control of the product in all the development process without the risk of using a black box computational tool.

ACKNOWLEDGMENT

The authors would like to acknowledge the financial support of Writing Lab, TecLabs, Tecnológico de Monterrey, Mexico, in the production of this work.

REFERENCES

- [1] Airfoil Tools, 2020
- [2] M. D., Kickmeier-Rust, E. C. Hillemann, and D. Albert, "Gamification and smart, competence-centered feedback: Promising experiences in the classroom," *International Journal of Serious Games*. vol. 1, no. 1, 2004.
- [3] R. D. Lorenz. *Spinning Flight*, Springer, New York, 2006.
- [4] J. B. Mauro. *An Introduction to Boomerangs*, Smith & Flannery, Inc., Richmond, VA, 1989. 3rd Ed.
- [5] M. J. Hanson, *The Boomerang Book*, Puffin Books, Harmondsworth, Middlesex, England, 1974.
- [6] M. Hanson, "The flight of the boomerang," *Physics Education*, vol. 24, no. 5, pp. 268-272, 1989.
- [7] H. Vos, "Straight boomerang of balsa wood and its physics," *American Journal of Physics*. vol. 53, no. 6, pp. 524-527, 1985.
- [8] J. C. Vassberg, "Boomerang flight dynamics," *Aerodynamics Lecture, New Orleans, Louisiana*. 2012.
- [9] A. Azuma, G. Beppu, H. Ishikawa, and K. Yasuda, "Flight dynamics of the boomerang, part 1: Fundamental analysis," *Journal of Guidance, Control, and Dynamics*, vol. 27, no. 4, pp. 545-554, 2004.
- [10] M. Hubbard, and A. L. Moore, *Sports Eng.*, vol. 17, no. 197, 2014.
- [11] F. Inocencio, "Using Gamification in education: A systematic literature review," *International Conference on Information Systems (ICIS) At: San Francisco, CA, USA 2018*
- [12] Ultimaker. [Online]. Available: <https://ultimaker.com/learn/ultimaker-cura-4-3-available-now>

Copyright © 2020 by the authors. This is an open access article distributed under the Creative Commons Attribution License ([CC BY-NC-ND 4.0](https://creativecommons.org/licenses/by-nc-nd/4.0/)), which permits use, distribution and reproduction in any medium, provided that the article is properly cited, the use is non-commercial and no modifications or adaptations are made.



Alejandro Guajardo-Cuñal is a mechanical engineer. He got his BS from the Universidad Autónoma de San Luis Potosí. He holds a MSc and a PhD from the University of Notre Dame in the US. He worked for Philips Lighting in Eindhoven, the Netherlands, and Hella in Guadalajara, Mexico. Currently he is a professor at Tecnológico de Monterrey, campus Guadalajara in Mexico. He is interested in

Educational Innovation, and energy transport using novel materials.

Diego Cárdenas is a mechanical and electrical engineer graduated from ITESM campus Monterrey in Nuevo Leon, Mexico, with a Master's degree in manufacturing technologies from the Harburg-Hamburg Technical University in Hamburg Germany and a PhD in Engineering from ITESM campus Monterrey, Nuevo Leon, Mexico.

He worked at Prolec-GE at the Center for Applied Technology in the design of new electric transformers. He is currently a research professor within the Group on Energy and Climate Change in ITESM campus Guadalajara, Jalisco Mexico. He specializes in modeling the interaction of fluid structure of wind turbine blades made from composite material.

Dr. Cárdenas is a member of the National System of Researchers in Mexico level 1, as well as being a part of "CEMIE Eólico".

Manuel Lepe is a Mechantronics Engineer from the Tecnológico de Monterrey campus Guadalajara. Currently he is a lecturer at Tecnológico de Monterrey. He is interested in 3-d printing and educational innovation.