

Faculty Members and Labs in Department of Computer Science

Hagiya Lab	Professor Masami Hagiya
<p><u>*No student recruitment in this Academic year*</u></p> <p>The world is full of computation! From Anshin-Anzen (reliable and safe) to Ayashii-Abunai (enigmatic and adventurous)</p> <p>While our laboratory has been working on formal verification of software and protocol (Anshin-Anzen), we are more and more interested in computational processes hidden in natural phenomena and conducting research with the ultimate goal of constructing artificial information processing systems employing those phenomena (Ayashii-Abunai).</p> <p>More concretely, with background in formal logic, our laboratory is seeking for new computational models and developing methods and tools for their analysis, verification and synthesis. In particular, we are investigating potential of computation not by conventional electronic computers but by natural phenomena including physical, chemical and biological ones (natural computation or unconventional computation), and conducting research on molecular computing, quantum computing, cellular computing, etc., and their applications (e.g., molecular computing to molecular robotics).</p> <p>http://hagi.is.s.u-tokyo.ac.jp/members/hagiya.html ← Hagiya's home page (in English) http://hagi.is.s.u-tokyo.ac.jp/rigakuru.pdf ← Introduction to the lab (in Japanese)</p> <p>Recent research projects:</p> <ul style="list-style-type: none"> * Model checking distributed software * Testing IoT protocol * Verification of quantum protocol * Analysis of quantum entanglement * Simulation of biomolecular reactions * Cellular Automata by a reaction-diffusion system <p>Our laboratory is also working on bioinformatics researches. We are studying various research topics from classical bioinformatics problems, such as genome sequence analysis and gene function prediction, to novel research fields such as the application of bioinformatics to ecology or ethology.</p>	
Imai Lab	Professor Hiroshi Imai
<p><u>*No Doctoral student recruitment in this Academic year*</u></p> <p>Our laboratory aims to introduce new computational models such as quantum computers with new quantum algorithms, to develop effective algorithms for fundamental and new research field such as huge network, machine learning, and to analyze complexities to represent difficulty of computing in sophisticated problems. We undertake a variety of studies ranging from fundamental theories to applied fields. Presently the issues we study include:</p> <p>(1) Design and analysis of algorithms to solve large graph problems, hard optimization problems such as SAT and Max Cut, graph decomposition, and machine learning.</p> <p>(2) Research on Quantum Computing and Quantum Cryptography; in particular, we have been investigating the following topics, fundamental theory for realizing quantum computers, quantum algorithms, quantum complexity theory to analyze computational ability of quantum computers, quantum information theory for quantum cryptography, and theoretical analysis of quantum information such as quantum entanglement. IBM Quantum Computers will be used to reveal the state-of-the-art power of the modern real quantum computer.</p> <p>(3) Analyzing graphs and matroids via their Tutte polynomial: This research includes many typical problems such as Ising mode in physics, which has direct connection with graph max cut, Jones polynomial of a knot, chromatic number, reliability function, etc. BDDs are used to represent this invariant polynomial in an implicit and compact manner, and are extended to quantum tree tensor network and other physical problems.</p> <p>(4) Machine learning algorithms for graphs and their optimization, including graph mining, graph neural network. Optimization problems related to this direction will be explored.</p> <p>http://www-imai.is.s.u-tokyo.ac.jp/</p>	

Suda Lab	Professor Reiji Suda
<p>Our laboratory researches on (1) parallel and high performance computing, (2) numerical algorithms and (3) data structures, aiming to higher speed, higher precision and higher reliability in large scale scientific computations.</p> <p>One target in parallel processing is very large scale supercomputers, which may contain millions of processors. One of our approach for forthcoming supercomputers is communication avoiding algorithms. They are designed to reduce the amount of inter-processor communication, which will be a significant cost in a large scale parallel computer with several millions of processors. Effective and efficient utilization of CPU multicore, which is becoming an order of 100, and their SIMD parallelism, and computational accelerators such as GPGPU are also important targets.</p> <p>Automatic performance tuning or autotuning is a mechanism that chooses the best implementation after several trial executions on the real machine. We are investigating mathematical methods to model the performance from the settings of tunable parameters, and to optimize tunable parameters efficiently, based on Bayesian statistics.</p> <p>We have worked on fast numerical algorithms with lower computational complexities. With the increase of scale and complexity of numerical computations, double precision sometimes fails to provide enough precision, and algorithms of high precision and/or high numerical stability are needed. Recently, high-performance low-precision arithmetic operations, required in machine learning algorithms, are becoming available in several architecture, and development of algorithms with clever utilization of those varieties of precisions would be interesting topics.</p> <p>As for data structure, our main target is space efficient data structures. Highly compact data structures applying data sensitive and/or lossy representations are especially relevant in bioinformatics, where bigdata-driven research paradigms such as metagenomics or pangenomics are emerging. We are also working on unconventional data structures with applications to security and privacy protection.</p> <p>http://sudalab.is.s.u-tokyo.ac.jp/~reiji/lab-e.html</p>	
Kobayashi Lab	Professor Naoki Kobayashi
<p>Our research group is studying theoretical foundations for software and their applications such as program verification. On the one hand, an increasing number of important systems such as transportation systems, medical devices, and banking systems are now controlled by computer software, and a bug of such software can cause a serious disaster. On the other hand, such software is becoming more and more complex and larger, and it is difficult to maintain the quality of software by using traditional software engineering technologies like testing. In view of these situations, we aim to improve the reliability and efficiency of software by developing automated techniques for program verification and transformation based on rigorous mathematical methods. To achieve the goal, we also need to study and advance many research topics in theoretical computer science, such as type theory, formal languages and automata, and automated theorem proving. It is a pleasure of our research to find out that deep mathematical results, which initially seem to be only of theoretical interests, are actually quite useful for the practically-motivated research mentioned above. See http://www-kb.is.s.u-tokyo.ac.jp for details.</p> <p>Recent research topics include:</p> <ol style="list-style-type: none"> 1. Higher-order model checking: This is an extension of traditional model checking that has been successfully applied to system verification. We have recently constructed the first higher-order model checker in the world. 2. Automated program verification: By applying the higher-order model checking mentioned above, we are developing fully-automated program verification tools for programming languages like ML and Java. 3. Data compression: String and tree data can be compressed in the form of programs that generate them. The higher-order model checking above can be used to transform such compressed data without decompression. 4. Type theory and program semantics: We are studying intersection type systems and game semantics as foundations for program verification and transformation. 5. Protocol verification: Cryptographic communication protocols are used, for example in Internet shopping, for safely exchanging confidential data. We are developing a method for automated verification of such protocols. 	

Igarashi Lab	Professor Takeo Igarashi
--------------	--------------------------

(1) User Interface: We are working on user interfaces for information appliances ranging from personal computers, smartphome, robots, and self-driving automobiles. We not only develop techniques to improve efficiency but also propose new ways of interaction.

- User interfaces for machine learning and artificial intelligence. We focus on the preparation of training data and interactive learning.
- Interaction techniques for novel appliances such as smartphome, smart watches, AI speakers and smart glasses.
- Interaction techniques for giving directions and controlling real-world systems such as robots and self-driving automobiles.

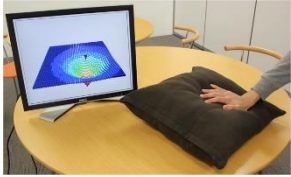

(2) Graphics: We mainly work on interactive shape modeling. We work on content creation for digital media such as movies and games. We also work on interaction techniques for digital fabrication using 3D printers and laser cutters.

- Content creation such as 3D modeling and 2D animation using recent technologies such as sketching and machine learning. We also work on interaction techniques for medical imaging.
- Shape modeling for real world objects such as musical instruments, clothes, and toys leveraging real-time physical simulation.
- Novel techniques for 3D scanning and 3D printing to support personal fabrication.

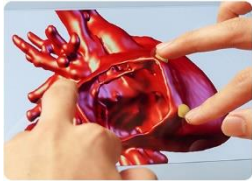

We can provide opportunity for students to collaborate with research groups in other countries and productions. <http://www-ui.is.s.u-tokyo.ac.jp/>

Miyao Lab	Professor Yusuke Miyao
-----------	------------------------

Natural Language Processing, Computational Linguistics, and Human Cognition

The goal of our research group is to make computers understand natural language. It is obvious that people communicate with each other using language, while its mechanism is still largely mysterious. We apply theories and technologies of computer science to modeling the process of understanding natural language. Specific research themes include: *syntactic parsing* to recognize latent structures of sentences, *semantic analysis* to recognize semantic structures, *recognizing textual entailment* to determine whether two texts express the same meanings or not. We also study research on *grounding*, which aims to connect language with non-verbal information such as vision and numerical data.

Additionally, our group is also engaged in developing real-world applications of natural language processing. Examples include *question answering systems* to answer questions by using text data and databases, *dialog systems* to communicate over smartphones etc., *natural language generation* to automatically explain various information in the world.

Refer to our homepage for the details of the research: <https://mynlp.is.s.u-tokyo.ac.jp/en/>

Syntactic/semantic parsing using
Combinatory Categorical Grammar

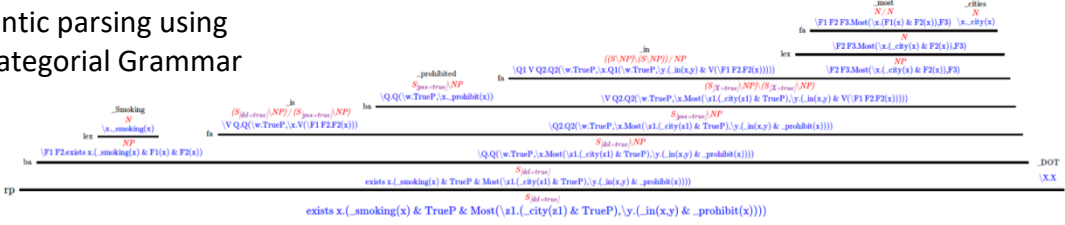

One of the major motivations to invent electronic computers was the application to science and technology. After the invention, the performance of the computers improved dramatically with the exponential development of semiconductor technology: Moore's law. Computational science, which advances science with computation has benefited greatly from the development. Nowadays, however, because the limitation of semiconductor technology is coming up to the surface, the complexity of computer systems such as parallelization etc. is so increasing that both computational science and computer science have to cooperate once again for the further progress. This laboratory was set up under the above background in August 2014 to perform education and research which connect computational science and computer science. (<http://www.cp.is.s.u-tokyo.ac.jp/>)

Yoshimoto himself is specialized in solid-state physics which elucidates the properties of materials such as semiconductors, metals, dielectrics, and magnets. Especially, he is specialized in the first-principles electronic structure calculations which accurately simulates the quantum mechanics of electrons which dominates most of the properties of materials. He has developed and open to the public a program package xTAPP for this purpose. The right-hand side figures are examples of visualization of an electronic structure calculation. (<http://xtapp.cp.is.s.u-tokyo.ac.jp/>)

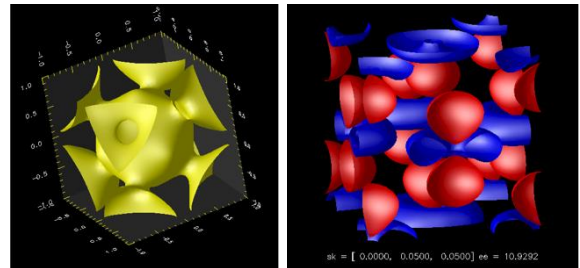

From the electronic structure calculation as a hometown, the aim of the laboratory set up between computational science and computer science is as follows:

1. Perform mutual exchange between wide range of fields in computational science by re-interpretation of the methods developed individually in each field from viewpoints of computer science.
2. Understand needs of computational science from viewpoints of computer science and propose more essential solutions.

Computing Platform Lab. (PFLab)

Our research interest includes computing platforms facilitating disruptive innovations. PFLab was founded in April 2016. Topics of special interest includes, but not limited to, the following:

- OS kernels for more than hundreds of cores on a chip.
- Real-time 3D data processing for peta-scale real-world data.
- System on a chip technology for mobile robots and AI.

100x performance and 0.01x power – this is what we want to achieve by our computing platform. We also study artificial intelligence (AI), robotics, sensing, and cloud computing for emerging real-world applications, such as autonomous vehicles and high-precision 3D maps. PFLab is in collaboration with foreign top-tier schools and automotive/electronics/technology/startup companies.

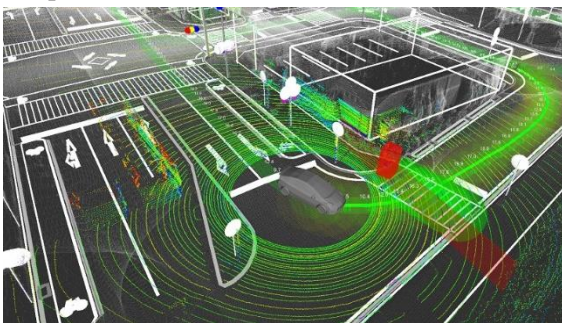

3D data processing

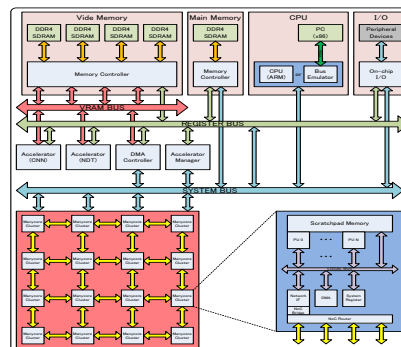

System on a chip for AI

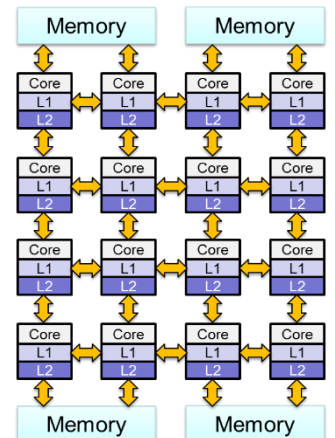

NoC-based many cores

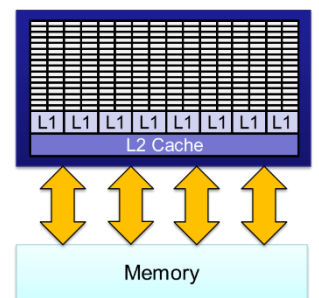

GPU-featured many cores

Takamaeda Lab

Associate Professor Shinya Takamaeda-Yamazaki

CASYS: Laboratory for Computer Architecture and Systems

Our main research interest is the future computer architecture, including (1) custom computing using FPGA and specialized LSI, (2) algorithm/hardware co-design for machine learning, (3) high-level synthesis compiler for hardware design. We are also pursuing software researches on compilers, programming models, and frameworks for user/programmer friendly computers. We have various active collaborations with companies. We tackle real problems with our innovative architectural technologies.

Recent research topics: (new topics are welcome)

- High-performance and low-power machine learning HW and architecture
- DNN model and training algorithm for embedded hardware
- Fast image processing algorithm and FPGA system
- Secure and high-performance microprocessor and memory system
- Annealing machine for large-scale combinatorial optimization
- Multi-paradigm high-level synthesis HW compiler in Python
- Customizable HW compiler for deep neural networks

Lab WEB: <https://sites.google.com/view/casys/>

GitHub: <https://github.com/PyHDI/> <https://github.com/NNngen/>

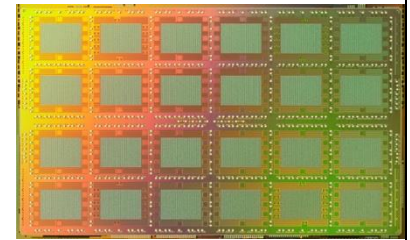

QUEST: DNN Processor

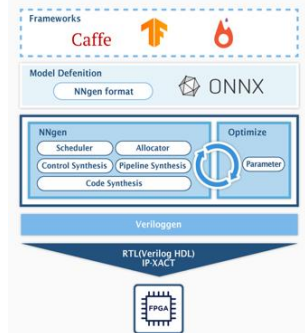

NNngen: DNN-HW Synthesis Compiler

Issei Sato Lab

Associate Professor Issei Sato

We humans decide our behaviors on the basis of knowledge learned and abstracted from past experiences and current situations. Machine learning is a field of artificial intelligence for improving the performance and behaviors of a machine through the use of data accumulated from past human experiences and current human interaction. The aim of machine learning is to automatically learn underlying mechanisms in observed data and extract hidden properties in data and make predictions yet to be observed.

"Without A Theory The Facts Are Silent"
—Friedrich August von Hayek.

We aim to develop learning algorithms that are theoretically guaranteed as much as possible on the following topics.

- Generalization, Robustness, & Stability : Study on generalization ability, robustness, and stability of machine learning algorithms including deep learning
- Uncertainty quantification : Study on how to quantify predictive uncertainty and assess its risk
- Representation learning : Study on learning data-feature representation directly from data without using supervised information
- Learning from few samples: Study on meta-learning for efficient learning from a small number of samples and transfer learning for knowledge transfer from different domains
- Human-in-the-loop : Study on learning algorithms based on feedback that is easy for humans

See <https://www.ml.is.s.u-tokyo.ac.jp/> for details.

Language allows people to communicate with great precision, and most of the information is composed of language. With the development of information technology, natural language processing (NLP) applications based on machine learning models with large corpora, such as information retrieval and machine translation, have been widely used in our daily life. However, it is not clear whether such applications understand the meaning of natural language in the same way that we do. We are working on developing NLP applications that has the capability of understanding natural language by integrating logic-based methods with machine learning.

(1) Probing language models through formal semantics

Do current language models understand the various meaning of natural language? They might learn undesired biases from the data. In this laboratory, we are analyzing language models from multiple perspectives of formal semantics and cognitive science.

(2) Hybrid inference systems by integrating machine learning-based approaches and logic-based approaches

To calculate the semantic relatedness between texts, machine learning models have been used for representing the meaning of texts. However, these models often use shallow information and it remains unclear whether they are capable of handling functional meanings of texts such as negations and quantifiers. By contrast, logic-based approaches have been successful in representing the functional meanings as logical formulas. To have advantages over both logic-based and machine learning-based approaches, we are developing hybrid inference systems by integrating machine learning-based and logic-based approaches.

(3) Hybrid NLP applications by combining human knowledge with hybrid inference systems

Depending on applications, such as document checking, it is not necessary to automate all processes. We are developing hybrid NLP applications by combining human knowledge with hybrid inference systems.

With the dramatic performance improvement of information and communication technology, intelligent information processing that was done only by humans is becoming possible also by computers. Under the theme of "how intelligent can computers be?", our laboratory is working on various research topics related to intelligent data analysis, called **machine learning**, in the field of artificial intelligence.

(1) **Construction of Learning Theory**

Generalization is the ability to cope with unknown situations, and is indispensable for computers to behave intelligently. We are theoretically investigating the mechanism of acquiring the generalization capability based mainly on probability and statistics.

(2) **Development of Learning Algorithms**

Machine learning involves various subjects such as supervised learning (learning from input-output paired data), unsupervised learning (learning from input-only data), and reinforcement learning (learning through interaction with an environment). We are developing practical and theoretically motivated machine learning algorithms.

(3) **Application of Machine Learning Technologies to Real World**

Growth and spread of the Internet and sensor technologies allow us to collect a huge amount of data in engineering and fundamental sciences such as documents, audio, images, movies, e-commerce, electric power, medicine, and biology. We are collaborating with industry partners and applying state-of-the-art machine learning technologies to solving real-world challenging problems.

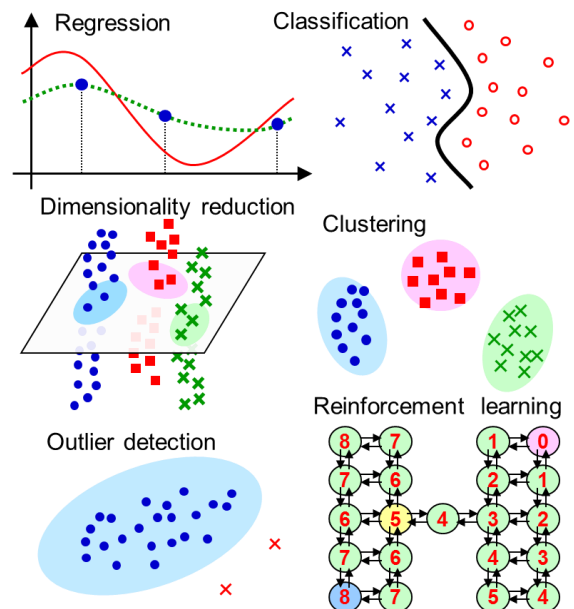

We study image processing for computational imaging and image analysis based on computer vision and machine learning. In particular, we work on intelligent information processing to automatically extract map information, such as land cover labels and elevation models, from remote sensing images acquired by spaceborne and airborne sensors.

(1) Image processing for computational imaging

Computational imaging, which integrates sensing and computation, allows us to acquire information that cannot be obtained by hardware alone and to overcome hardware limitations, such as resolution and noise. Based on machine learning, optimization, and signal processing, we build mathematical models and develop algorithms to recover unknown original signals from incomplete observation data.

(2) Remote sensing image analysis

Remote sensing enables us to observe places that are inaccessible to humans; however, it is difficult to collect enough training data due to the limitations of field surveys and visual interpretation. We work on mapping and 3D reconstruction by using synthetic data from simulations and inaccurate labels with low collection costs as training data. We also work on data fusion based on deep learning to handle multimodal data obtained from different spaceborne sensors in an integrated manner.

(3) Image analysis for solving global issues

We promote projects to solve global issues, including environmental problems, climate change, large-scale natural disasters, and food problems. Our goal is to contribute globally to the realization of the SDGs by solving real-world problems, such as assessing building damage during disasters, estimating biomass and carbon stocks in forests, and mapping crop types, in collaboration with related institutions and researchers in Japan and overseas.

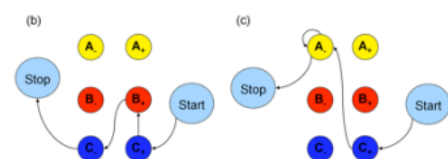
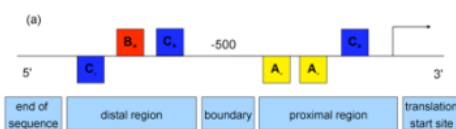
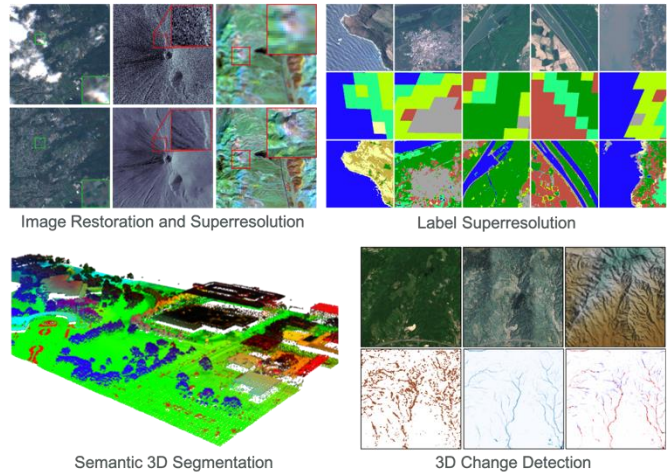

Our laboratory focuses on bioinformatics, like two other labs in the Shirokanedai campus, where a huge super-computer system is available. Prof. Nakai's fundamental research interest is to elucidate how the biological information is encoded as 1-dimensional character strings (sequences). It is well established that such 'information for life' is basically encoded as the chemical structure of a set of DNA molecules, called the genome, which is kept within each cell. Its necessary part is copied into another kind of molecules, RNAs, which are then used to synthesize various proteins for various purposes. Thus, there can be three levels for our study (DNA, RNA, and protein). Currently, we are mainly interested in understanding how the

regulatory information for reading only necessary parts is encoded in the genome DNA. The attached figure shows our model of the structure of regulatory regions deduced from a set of genes that are read out in the same cells. The model is probabilistically represented using the Markov chain. Once such a model is made, we can predict unknown genes that are regulated in the same manner and such predictions would be verified experimentally.

Although we belong to the computer science department, our research projects are rather biology-oriented.

Nevertheless, students with any background would be welcome if they are interested in bioinformatics. In fact, another feature of our laboratory is that the majority of the members are international students/staffs. In principle, we would like to support each student's spontaneous motivation, and each research project will thus proceed independently. We will, however, try to ensure that these projects will become stimulating for each other. Please visit <http://fais.hgc.jp> for details.

Imoto and Katayama Lab	Professor Seiya Imoto Associate Professor Kotoe Katayama
------------------------	---

Imoto lab is focusing on the development of data analysis technologies for health-medical big data. Currently, the cost of whole-genome sequencing analysis for an individual runs about or less than thousand USD. This cost should be decreased to hundred USD within several years. At that time, it is obvious that almost all of us can have own whole-genome sequence information. Under this perspective, it is necessary to develop methods that can use genomic big data of several million people's whole-genome sequence information for the prediction and prevention of diseases and improving our health. Based on genomic big data including whole-genome, transcriptome, epigenome and meta-genome, and time-series information of health and medical records, we address this problem by utilizing statistical data analysis technologies and supercomputing under the collaboration with researchers in companies and universities.

We are pursuing the following research (but not limited):

Research theme 1: Development of genomic data analysis methods

We have been developing Bayesian models for analyzing genomic regions related to immune response including human leukocyte antigen (HLA), T-cell receptor repertoire and meta-genome, and for analyzing cancer genome to detect somatic mutations more accurately. Especially, in the International Cancer Genome Consortium, we analyzed whole-genome sequence data of about 3,000 cancer patients to investigate the relationship between genomic mutations and human immune system.

Research theme 2: Development of mathematical modeling techniques for systems biology

We are developing modeling techniques for biological systems formed by tens of thousands of molecules, including genes and non-coding RNAs, and developing data analysis methods to predict the effects of drugs and the future development of diseases.

Research theme 3: Artificial intelligence for translating health-medical big data to medical actions

From the analysis of cancer genome, we will detect genomic mutations of several thousands to tens of thousands. We next detect causal genomic mutations for cancer from the list of genomic mutations. So, we need to interpret the genomic information. Although the interpretation of genomic information is based on the published literature, if we focus on cancer research, several hundreds of thousand research papers are published per year. It is obvious that comprehensive utilization of such a huge amount of information is beyond human capacity. We investigate to utilize artificial intelligence to solve this problem.

Please come to our web site (<https://www.hm-intelligence.com/>). You can find more information about the research theme and our recent activities and achievements.

Shibuya Lab	Professor Tetsuo Shibuya
-------------	--------------------------

Medical Science is now dramatically changing. It is mainly due to the advent of next generation sequencers that can sequence DNA with incredibly high speed and low cost. State-of-the-art computer science techniques are required to deal with the enormous amount of medical big data. We aim to develop fundamental big data technologies that could drive medical science to the next stage.

Research topics in our lab:

(1) Big data indexing / searching

Development of faster, more accurate, and scalable indexing/searching technologies are highly desired in the era of individual genomic medicine, where we might need to deal with tremendous country-wide individual genomic data.

(2) Privacy preserving computation

Genome is the ultimate individual information to be protected. We need to develop privacy preserving computation technologies, such as differential privacy and secret computation, to meet ethical requirements from genome data.

(3) Machine learning / AI algorithms for medical science data

Development of accurate prediction algorithms for medical big data is always required.

(4) Application to clinical sequencing

We need to apply our results to actual applied medicine, such as clinical sequencing.

Our theme is not restricted to the above. We think we have infinite possibilities to change the world of medical science, molecular biology, drug discovery, etc., by developing novel big data technologies for them.

Home page: <http://shibuyalab.hgc.jp>

Nakata lab	Professor Toshiyuki Nakata
------------	----------------------------

No student recruitment in this Academic year

Applying Cyber Physical systems (IoT) to real world social problems is expected to solve a number of serious hazards such as aging society, food shortage, energy crisis, and decrease in the labor population. On the other hand, current cyber physical systems are usually applied to relatively small problems and have not been applied to large scale real world problems.

Our research focuses on large data processing technologies which can be the basis for building large scale high performance computing systems which would make social scale cyber physical systems a reality. Some of the potential research themes are shown below.

- Research on efficient methods for big data processing. This research focuses on big data processing using large scale big data processing platforms methods such as Hadoop / Spark. Efficient processing using parallel/processing technologies, GPGPU's and fast I/O technologies.
- Research on efficient processing of AI / Machine Learning using the above platforms.
- Research on architecture and methodologies for efficient cooperation between the cloud systems and the edge nodes.
- Research on linking Open Data processing and big data processing
- Research on real world modelling and simulation

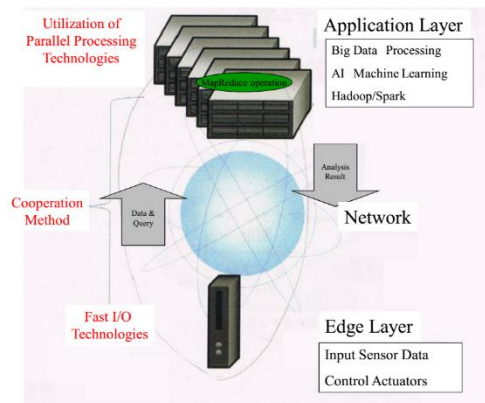

Research on big data processing using real world data in collaboration with other laboratories

Shimizu Lab	Professor Kentaro Shimizu
-------------	---------------------------

No student recruitment in this Academic year

We conduct extensive bioinformatics studies at different levels ranging from protein structure and function analysis to genome and transcriptome analysis using a wide variety of methods, such as machine learning, statistical analysis, and molecular simulation. Below are some of the areas of our research:

- High-resolution protein structure prediction
- Prediction of binding sites between proteins and other molecules (proteins, nucleic acids, sugar chains, lipids, metals, low-molecular-weight compounds, etc.)
- Docking prediction (prediction of complex structures in the bound state)
- Various functional predictions

In addition, by analyzing the dynamics of proteins, we conduct studies in the following areas: process of binding of molecules and other physicochemical properties such as free energy, interatomic interactions in vivo, and simulation of the process of protein folding. Recently, we are involved in research associated with the analysis and prediction of various structural features of intrinsically disordered regions and membrane proteins, which are important for protein function. In collaborative investigations with experimental researchers, we are engaged in agricultural bio research, which is related to medicine, food, and environment, such as enzyme modification, drug development, functional foods, and environmental purification. <http://www.bi.a.u-tokyo.ac.jp/>

Protein–ligand-binding site prediction (red color is the predicted site, gray denotes the actual ligand)

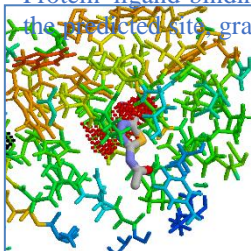

Coarse-grained molecular dynamics simulation of protein–ligand-binding (Analysis of the movement of ligands into a pocket along the protein surface)

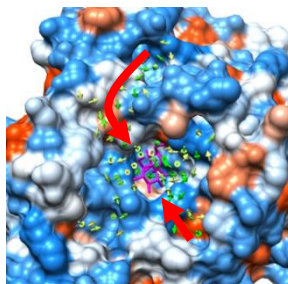

Automatic generation of a ligand-binding site prediction tool.

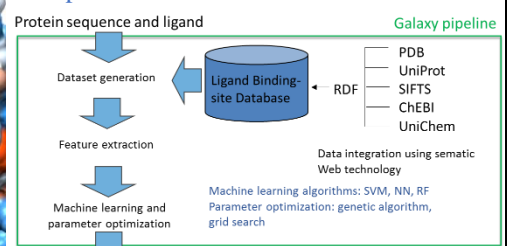

Takano Lab	Professor Akihiko Takano
<p><u>*No student recruitment in this Academic year*</u></p> <p>(1) Algebra of Programming: To establish a scientific method for program construction, the rich collection of software parts with correctness proofs and the flexible way to combine those parts into working software with required function and efficiency are crucial. Algebraic foundation of program fusion, partial evaluation, and data transformation are studied in this perspective.</p> <p>(2) Informatics of Association: How to vitalize our association using vast collections of digital information is investigated. Association computation is formulated as a computational basis for efficient evaluation of similarity among documents or words. GETA is a scalable and efficient implementation of this computation. The GUIs for creative interaction with digital information based on association are studied. Here are some examples of the information services we launched as our research products.</p> <ul style="list-style-type: none"> - Webcat Plus (http://webcatplus.nii.ac.jp/) - Cultural Heritage Online (http://bunka.nii.ac.jp/) - Shinsho-Map (http://shinshomap.info/) - IMAGINE Book Search (http://imagine.bookmap.info/) 	
Aizawa Lab	Professor Akiko Aizawa
<p>Our laboratory's research is focused on natural language technologies to assist human intelligent activities. Our major challenges include the following subjects in text and media studies that are based on machine learning including deep learning, statistical modeling and analysis, or annotation and corpus analysis.</p> <ul style="list-style-type: none"> (1) Text mining: document structure analysis and information analysis; information identification and entity disambiguation; automatic construction of linguistic resources (2) Machine reading comprehension: Exploiting the semantic structure of natural language; extracting knowledge and information from natural language (3) Modeling human language activities: Measuring and analyzing language activities in text media <p>Our recent research topics are as follows: machine reading comprehension, design and analysis of natural language understanding tasks, real document processing, retrieval and understanding of mathematical expressions, information identification and linkage, and recommendation and English writing assistance for academic researchers. We also welcome new research topic proposals related to natural language processing and information retrieval.</p> <p>Our research facilities include variety of information resources and a large-scale computation platform at NII. Students are encouraged to act as independent researchers/engineers by being allowed to join seminars and discussion groups with interdisciplinary and international researchers and to participate in related joint research activities at NII.</p> <p>http://www-al.nii.ac.jp/en/</p>	

Analyzing Light Transport for Scene Understanding

The appearance of an object changes significantly depending on its shapes, surface reflectance properties, and the lighting condition of the scene in which it is placed. Given an unknown picture, it might not so difficult for us to obtain different kinds of information about the objects in the image. However, it turns out to be an difficult task for a computer to figure out. In the past, techniques for automatically modeling and analyzing the photometric and geometric information of a scene have been studied in the fields of both computer vision and computer graphics research.

Furthermore, some researcher showed that the spectral reflectance and emission of objects provides innate information about material properties that have proven useful in applications such as classification, synthetic relighting, and medical imaging to name a few. In our lab, we analyze different types of optical phenomena including spectral reflectance, absorption, subsurface scattering, and fluorescence emission for modeling and understanding real scenes.

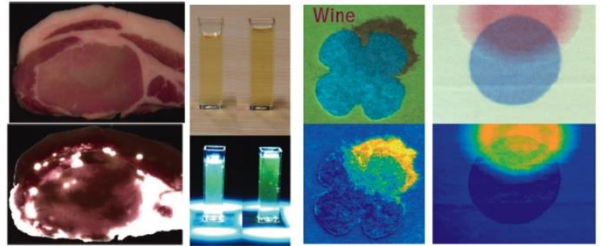

Visualization of bacteria growth (right) and classification of liquids (middle) by the fluorescence excitation-emission characteristics. Recovering the original surface color and the degree of wetness (left).



Blood vessels analysis by machine learning.

Message

Seeing is believing: the goal of computer vision is to understand how humans process and use visual information for understanding the surrounding world. There are so much excitement in analyzing real scenes using cutting edge technologies. Please join us and share a feeling of accomplishment with our lab members!

<http://research.nii.ac.jp/pbv/index.html>