

KWM Gutterman INC.

FASCIA Seamless Roll former Machine OPERATING AND MAINTENANCE TROUBLE SHOOTING GUIDE

TABLE OF CONTENTS

SECTION	PAGE #
1. Machine Specifications	pg. 3
2. Safety and General Maintenance	pg. 4
3. Mounting Machine	pg. 4
4. Fascia Gutter Machine Orientation	pg. 5
5. Electrical Controls	pg. 6
6. Electrical Cord Requirements	pg. 6
7. Wiring Diagrams	pg. 7-8
8. Spool Upright Assembly	pg. 9
9. Spool Assembly and Loading Coil	pg. 9
10. Spool & Upright Drawing	pg. 10
11. Entrance Guide System	pg. 11
12. Entrance Guide Assembly Drawing	pg. 11
13. Adjusting Entrance Guide System	pg. 12
14. Daily Operating Procedures	pg. 13
15. Polyurethane Drive System	pg. 14
16. Polyurethane Drive System Drawing	pg. 15
17. Forming Components and Assemblies	pg. 16
18. Adjusting Lip box Assembly – Entrance	pg. 17
19. Adjusting Lip box Assembly – Exit	pg. 18
20. Adjusting Swing Shaft Assembly	pg. 19
21. Exit Forming and Drive Assembly	pg. 20-21
22. Bell Wheel Roller Assemblies	pg. 22
23. Bead Roller Assembly	pg. 23
24. Guillotine and Face Plate Assembly	pg. 24
25. Guillotine and Face Plate Assembly Drawings	pg. 25
26. Machine Operation Recap and Summary	pg. 26
27. Analyzing Gutter	pg. 27
28. Gutter Talk	pg. 28
29. Trouble Shooting	pg. 29-31
30. Gutter Profiles	pg. 32
31. Warranty Information	pg. 33

SECTION 1

FASCIA GUTTER MACHINE SPECIFICATIONS

POWER:

- 3/4 HP, FAN COOLED (T.E.F.C.) MOTOR
- SINGLE PHASE
- 110V
- 13.6 AMP

DIMENSIONS:

- LENGTH 151” (383.5 cm)
- HEIGHT 48” (122.0 cm)
- WIDTH 24” (61.0 cm)

WEIGHT:

- APPROX. 1450 LBS. (657.7 kg)

DRIVE:

- TOP AND BOTTOM POLYURETHANE ROLLERS
- VIA CHAINS & SPROCKETS

SHEAR

- FRONT PULL GUILLOTINE STYLE SHEAR

SPEED:

- APPROXIMATELY 35’ PER MINUTE

CONTROLS:

- **ENTRANCE END**
 - o EMERGENCY STOP
 - o JOG PUSH BUTTON

- **EXIT END**
 - o EMERGENCY STOP
 - o FORWARD & REVERSE SWITCH
 - o RUN & JOG PUSH BUTTON

RECOMMEND MATERIALS:

- PAINTED STEEL (MAX: 24 GAUGE)
- GALVANIZED STEEL (MAX: 24 GAUGE)
- ALUMINUM STEEL (MAX: 24 GAUGE)
- TERNECOAT STEEL (MAX: 24 GAUGE)
- ALUMINUM (MAX: .032” THICK)
- COPPER (MAX: 16 OZ. 3/4” HARD)

SECTION 2

SAFETY AND GENERAL MAINTENANCE

- Read the entire manual prior to operation of this machine.
- Always keep covers and lids on during transportation, operation and storage. The covers are for the operator's safety. Not only will this protect the operator against injury, the covers protect the machine from outside elements.
- Do not transport or store machine with gutter coil in the machine. The forming rollers have adequate spacing, which will not allow them to come in contact with each other. The polyurethane drive rollers do not need to be protected from each other.
- Read all warning labels on machine.
- Disconnect the machine from power source prior to cleaning, or performing any maintenance.
- Perform a daily inspection for debris, loose nuts, and or bolts. With a clean machine you can expect longer life from your machine and a better-finished product.
- Lubricate guillotine and chains weekly using waterproof synthetic grease.
- Gearbox oil level should be inspected annually. The gear oil level should be even with the bottom of the inspection hole.
- Be sure the operator is trained in the operating procedures of this equipment, and all local and national safety codes concerning the operation and the lifting of coils.
- **OUTSIDE STORAGE.** If machine must be stored outside on an open trailer, tarp machine loosely providing good ventilation to prevent condensation.

SECTION 3

MOUNTING MACHINE

Mounting machine in truck and or trailer.

- When choosing a vehicle or trailer for your machine, consider the gross machine weight including coil.
- Check mounting surface for its integrity and make any repairs necessary prior to installation.
- Bolt machine to the bed of the vehicle using 3/8" diameter grade 5 bolts four places.
Do not draw machine down to an un-flat surface; shim as needed to insure four place mounting.

SECTION 4

FASCIA MACHINE ORIENTATION

Machine orientation is as follows: (For communication purposes in the manual.)

A. ENTRANCE

The ENTRANCE is where the forming process begins, where the material is fed.

B. EXIT

The EXIT is where the forming process is complete and the finished gutter exits the machine.

C. RIGHT SIDE

The RIGHT SIDE of the machine is determined when facing entrance end of the machine.

The RIGHT SIDE is where the LIP or FACE of the gutter is formed.

COMPONENTS ON RIGHT SIDE:

1. Lip Side Guide Shoe (Right Shoe)
2. Lip Side Guide Bar Assembly
3. Lip box Assembly
4. Face Bell Wheel Assembly

D. LEFT SIDE

The LEFT SIDE of the machine is determined when facing the entrance end of the machine.

The LEFT SIDE is where the BACK of the gutter is formed.

COMPONENTS ON LEFT SIDE:

5. Back Side Guide Shoe (Left Shoe)
6. Back Guide Bar Assembly
7. Motor and Gear Box
8. Back Bell Wheel Assembly
9. Bead Roller Assembly

E. CENTER OF MACHINE

The CENTER OF MACHINE components form bottom section of gutter and are the drive assembly.

COMPONENTS IN THE CENTER OF THE MACHINE:

10. Entrance Guide Assembly
11. #1 Skate Assembly
12. #1 Drive Assembly
13. #2 Skate Assembly
14. #2 Drive Assembly
15. #3 Skate Assembly
16. #3 Drive Assembly
17. #4 Skate Assembly
18. Exit Drive Assembly
19. Front Pull Guillotine Assembly

SECTION 5

ELECTRICAL SYSTEM AND CONTROL LOCATIONS

1E. MAIN OPERATORS PANEL

The MAIN OPERATOR'S PANEL is located on the right side at the exit end of the machine.

THE MAIN OPERATOR'S PANEL CONSISTS OF:

- 2 SELECTOR SWITCHES
 - JOG-RUN
 - FORWARD-REVERSE
- 2 PUSH BUTTONS
 - START (GREEN)
 - STOP (RED)
- DUPLEX RECEPTACLE
 - ACCESSORY POWER SUPPLY

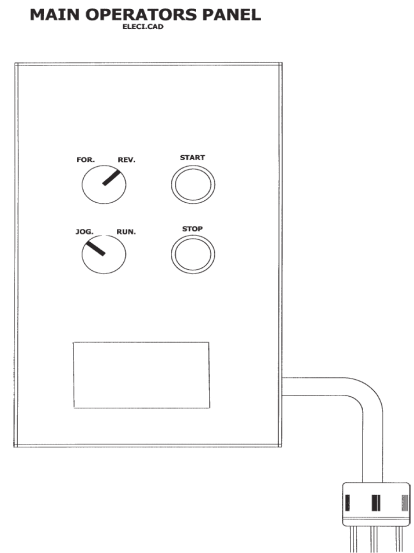

2E. ENTRY OPERATORS PANEL

The ENTRY OPERATOR'S PANEL is located on the right side at the entrance end of the machine.

THE ENTRY OPERATOR'S PANEL CONSISTS OF:

- 1 PUSH BUTTON
 - JOG (GREEN)
- POWER SHUT OFF
 - EMERGENCY STOP BUTTON (RED)

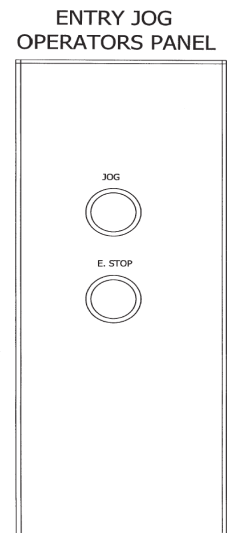

3E. POWER SOURCE PLUG

The POWER SOURCE PLUG is located at the exit end of the machine on the right side.

SECTION 6

ELECTRICAL CORD REQUIREMENTS

It is important that the motor manufactures minimum wire gage be adhered to in order to maintain the warranty on motor.

<u>LENGTH</u>	<u>GAGE CORD</u>
0 – 25'	12 ga
25 – 50'	10 ga
50 – 100'	7 ga

SECTION 7 WIRING DIAGRAMS

IRONMAN 110V - PUSH BUTTON WIRING DIAGRAM

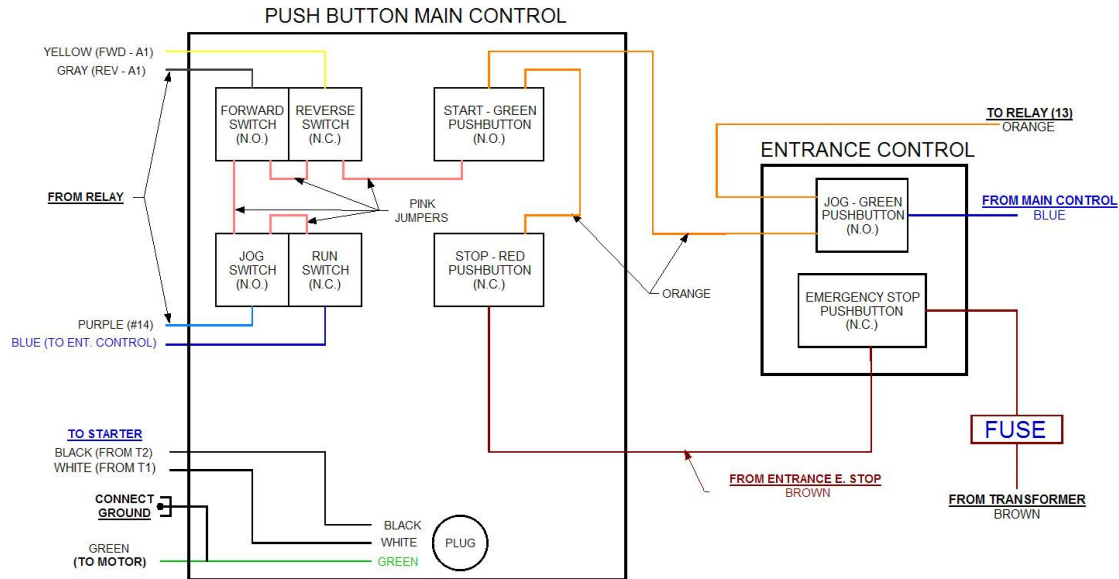

IRONMAN 110V - WIRING DIAGRAM

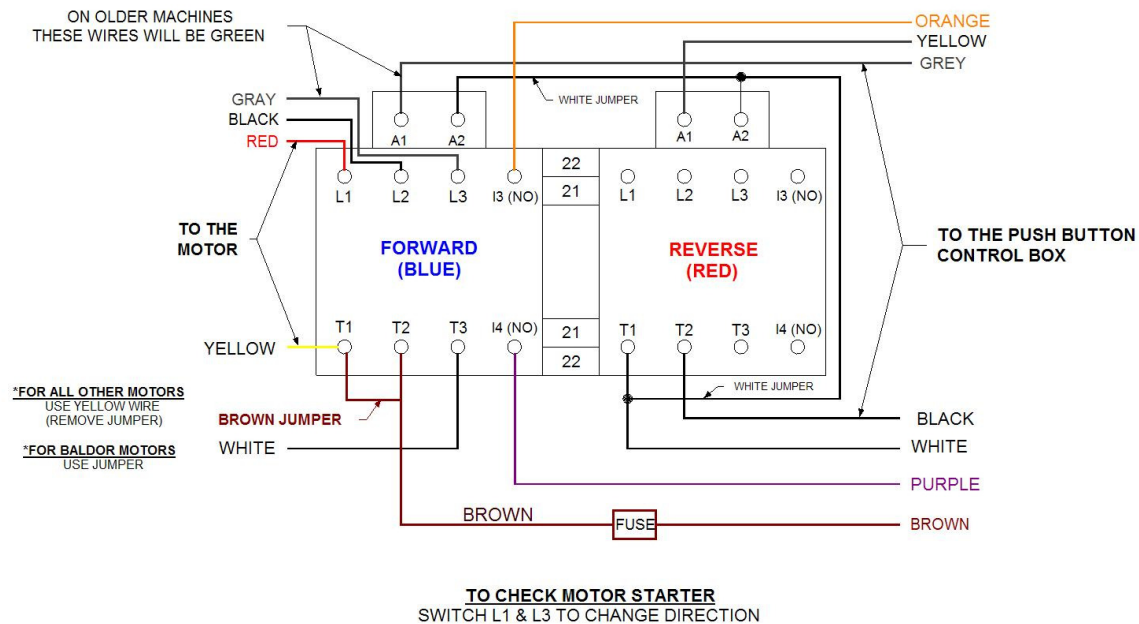

IRONMAN 220V - PUSH BUTTON WIRING DIAGRAM

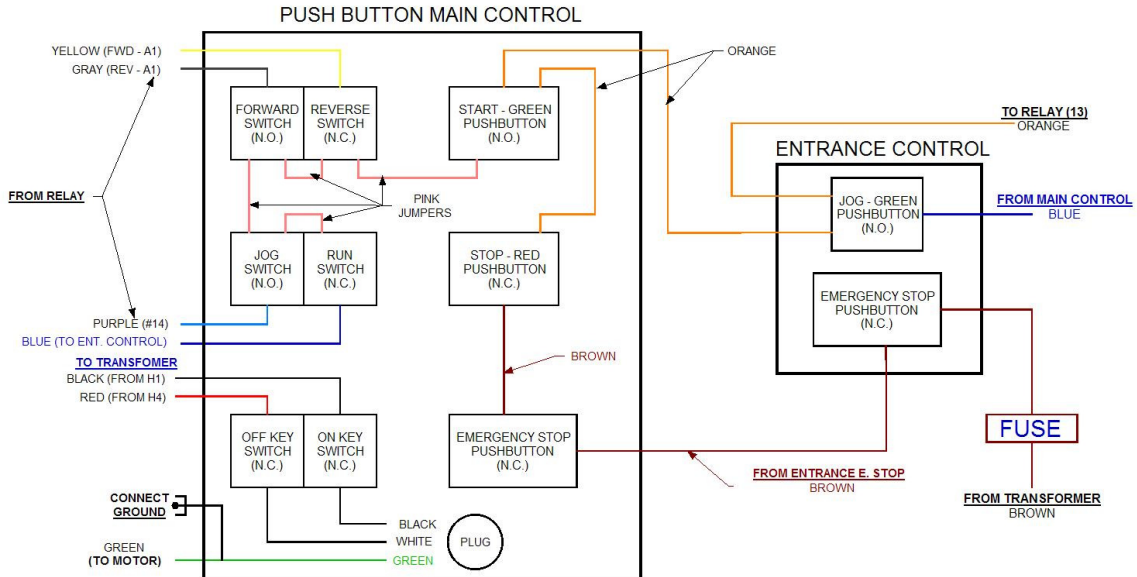

IRONMAN - 220V WIRING DIAGRAM

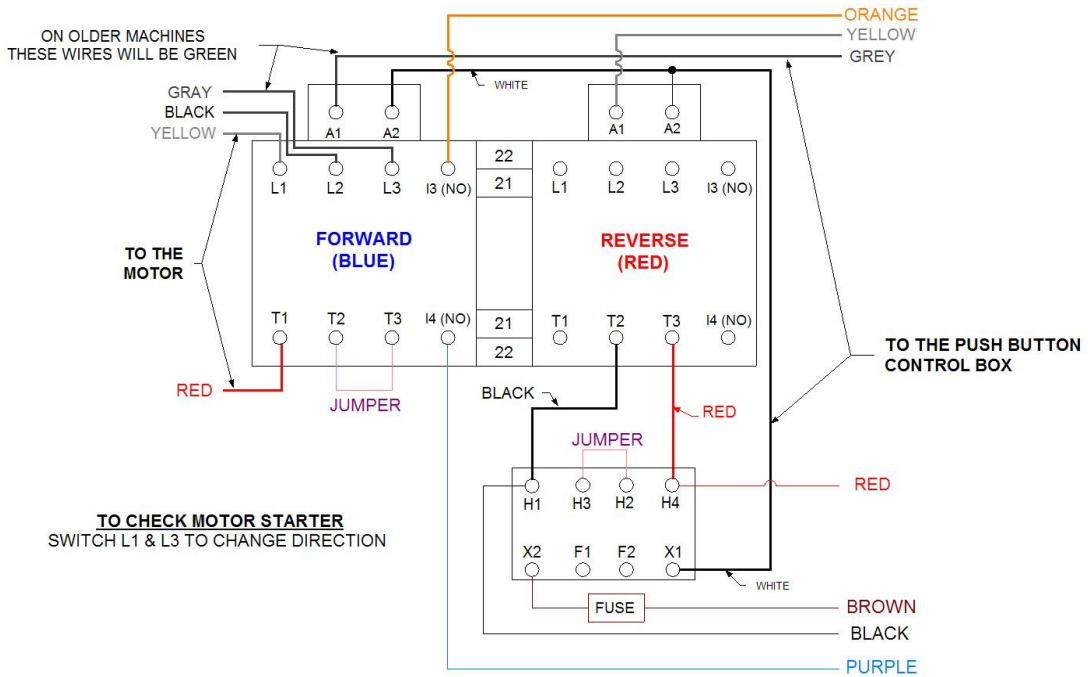

SECTION: 8

SPOOL UPRIGHT SUPPORTS

The IRONMAN TURNSTILE UPRIGHT is a modular turnstile support used to hold coil. Your machine may have up to three uprights.

ONE TURNSTILE UPRIGHT ASSEMBLY CONSISTS OF: (SEE PG. 10)

TURNSTILE UPRIGHT (1)	TENSION BRAKE (2)
BASE PLATE (1)	THUMB SCREW (2)
TURNSTILE LOCKING PIN (1)	SAFETY PIN (2)

TO ROTATE TURNSTILE FOR TWO-SIDED COIL:

1. Disengage the TURNSTILE LOCKING PIN.
2. Rotate TURNSTILE 180 degrees.
3. Re-engage the TURNSTILE LOCKING PIN.

SECTION: 9

SPOOL ASSEMBLY AND LOADING COIL

ONE SPOOL ASSEMBLY CONSISTS OF: (SEE PG. 10)

SPOOL SHAFT (1)	SPOOL HALVES (2)	5/16" QUICK RELEASE PIN (2)
-----------------	------------------	-----------------------------

TO LOAD COIL ONTO SPOOL ASSEMBLY:

1. Place the empty spool assembly on the ground or on a flat surface.
2. Remove one of the 5/16" quick release pins.
3. Slide the spool half off of the 1/4" spool shaft.
4. Insert the spool shaft through the center of the coil.
5. Replace spool half on the spool shaft, and reinstall the 5/16" quick release pin.
6. The spool assembly and coil are now ready to load onto the upright.

NOTE: The spool assembly is adjustable to accept both 5" gutter material (11 3/4" – 12") and 6" gutter material (15").

PLACING SPOOL & COIL IN THE UPRIGHT:

Use an approved lifting device in the designated spool lifting area to position the spool assembly into the turnstile upright. (***IMPORTANT! – Please read PRECAUTIONS***)

PRECAUTIONS:

- Make sure loading area is clean and clear of debris.
- Make sure Turnstile Locking Pin is securely installed.
- Always wear protective footwear when handling coil.
- Never load coil with the brake in closed position.
- Never operate machine without first checking brake & pin positions.
- Never transport machine without locking brake in closed position

SECTION 10

SPOOL & UPRIGHT ASSEMBLY

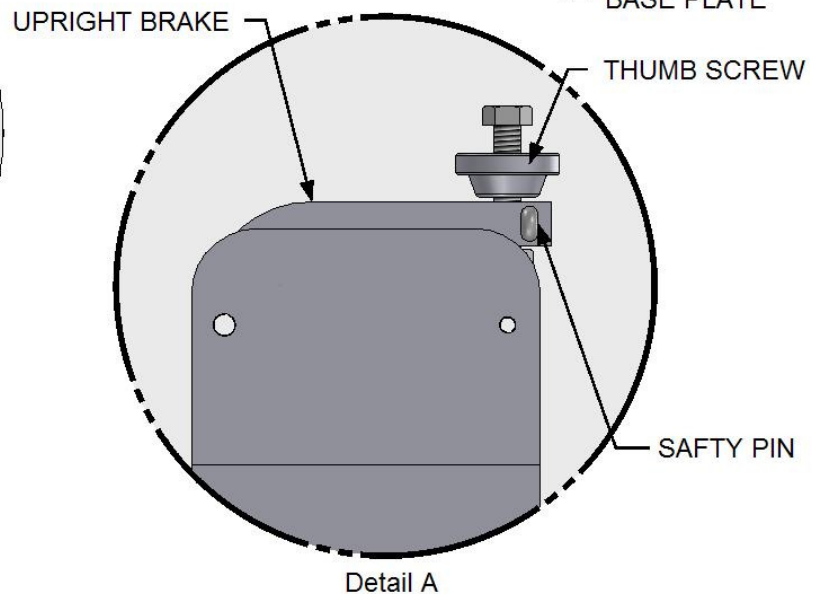
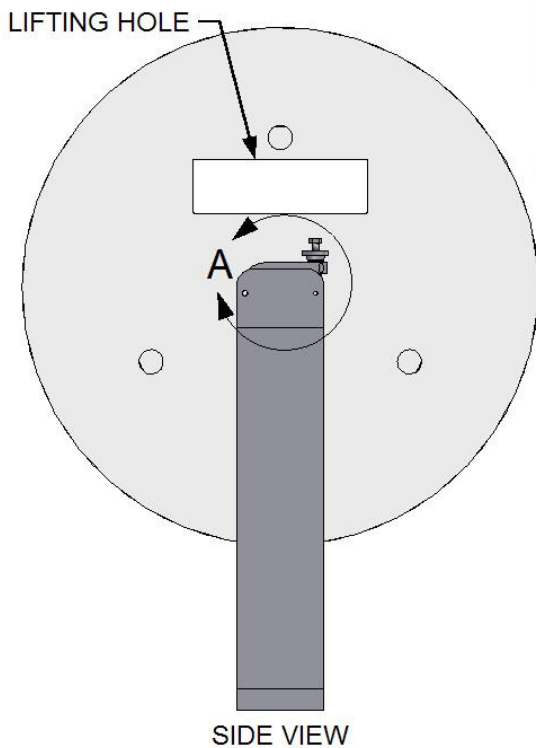
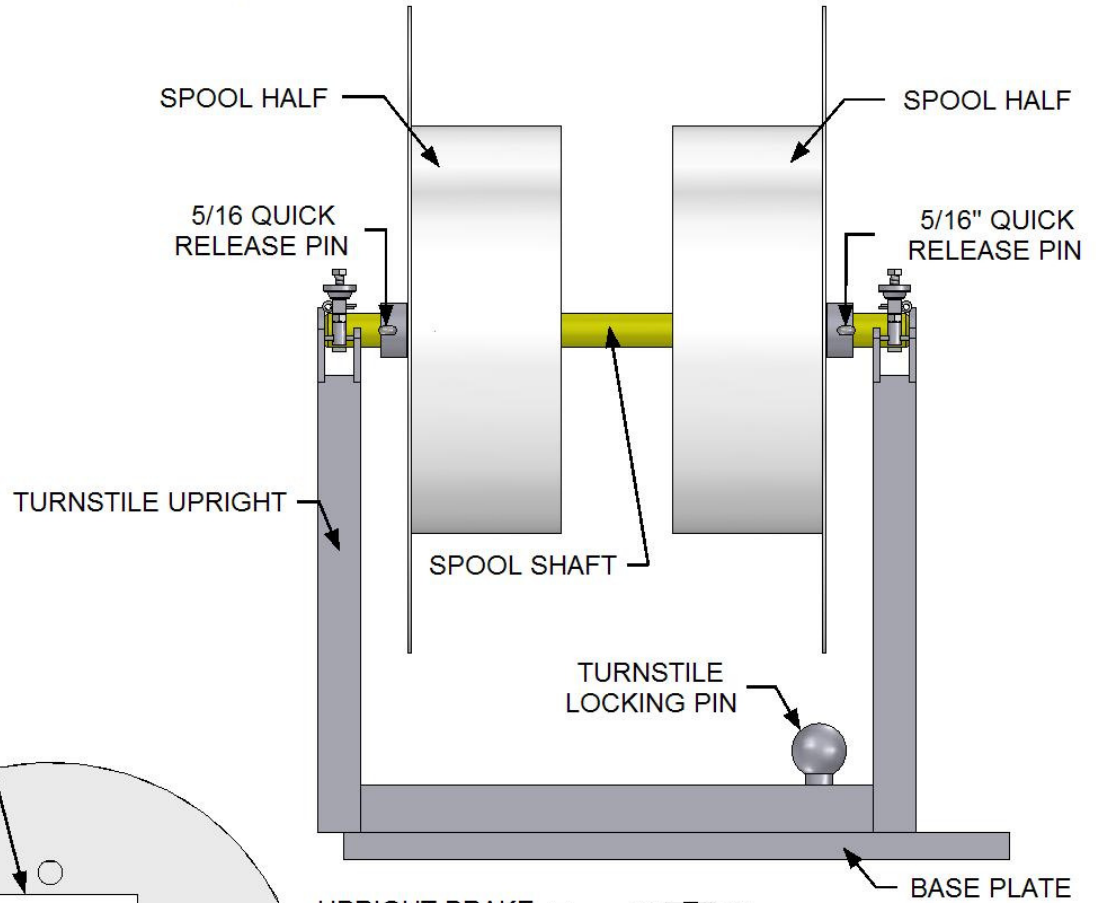
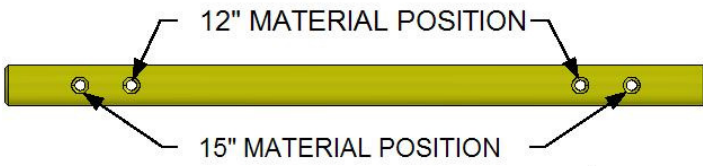

SECTION 11

ENTRANCE GUIDE SYSTEM

1. Purpose and precautions of the entrance guide system.

The entrance guide system is a very important part of this machine. Not only is it used to position material being fed into the machine; it also controls the lateral relationship of the material to the forming stations.

2. Entrance guide consists of:

- | | |
|--------------------------------|--|
| A. Right Aluminum Guide Roller | F. Top Rubber Drive Roller |
| B. Left Aluminum Guide Roller. | G. Bottom Rubber Drive Roller |
| C. Right Locking Set Screw. | H. Bottom Rubber Drive locking Collars |
| D. Center Locking Set Screw | I. Plastic Rollers. |
| E. Left Locking Set Screw. | |

3. Entry Guide Operation.

When feeding material from the spools on the top of the machine or from a remote station, position the material in the middle of the entry guide top plastic rollers and between the entrance rubber drives. Turn the handle to feed material until it stops at the first chain driven rubber drive. **DO NOT FORCE.** The material can now be jogged through the machine. If the drive roller does not pull the material into the machine, give the material a little push from the entry end while continuing to jog the material into the machine.

SECTION 12

ENTRANCE GUIDE ASSEMBLY DRAWING

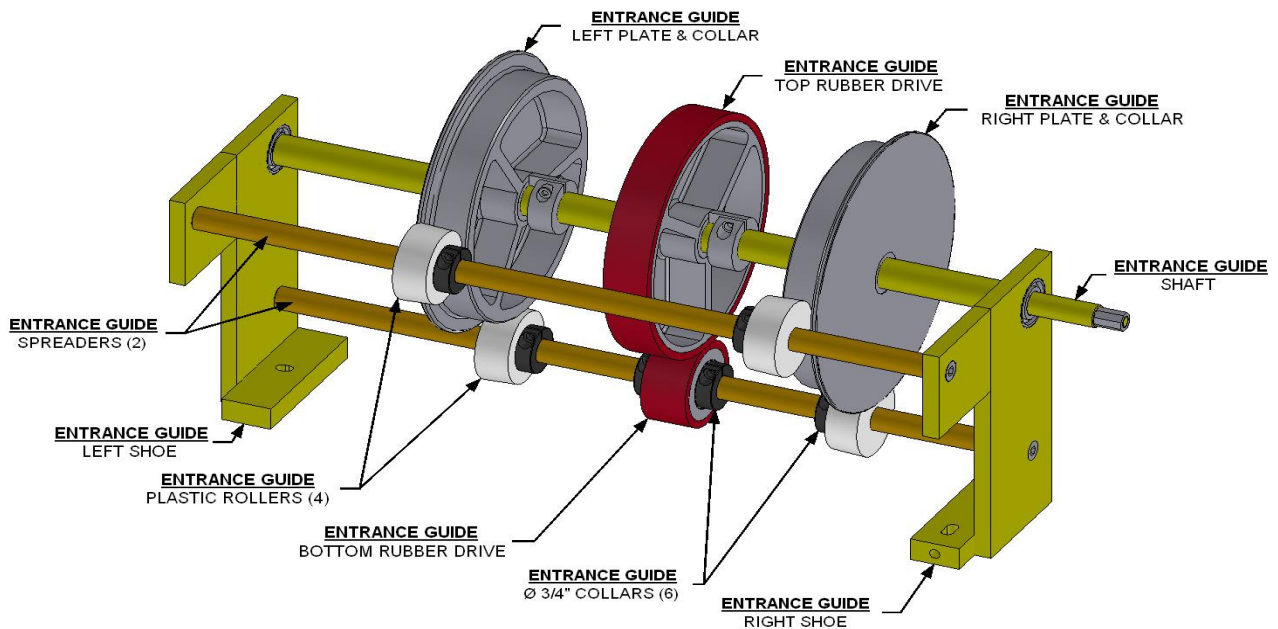

SECTION 13

ADJUSTING ENTRANCE GUIDE SYSTEM

THE LOCATIONS OF THE ENTRANCE GUIDE ROLLERS ARE FACTORY SET AND SHOULD NOT BE ALTERED UNLESS AUTHORIZED – PLEASE CALL

To INCREASE THE AMOUNT OF LIP TURNED UNDER;

Move the entrance guide plates toward the right side (face side) of the machine.

To DECREASE THE AMOUNT OF LIP TURNED UNDER;

Move the entrance guide plates toward the left side (back side) of the machine.

TO MOVE GUIDES

- 1.) Loosen the setscrews on right collars.
- 2.) Slide right plate and plastic rollers towards the desired direction.
- 3.) Tighten setscrews.
- 4.) Loosen the setscrews on left collars.
- 5.) Slide left plate and plastic rollers to material width.
- 6.) Tighten setscrews.

NOTES:

SECTION 14 **DAILY OPERATION**

Feeding Machine

1. Position selector switch to jog. (see pg.6)
2. Position selector switch to forward position. (see pg.6)
3. Remove spool retaining pins and loosen breaks (see pg.10)
4. Trim corners of coil 3" X 3" (see below)
5. Standing at entrance of machine, position material in the center of the entrance guides and hand feed to material between the rubber drives. (see pg.11)
6. Use handle on lip side to feed material to 1st chain drive.
7. Activate entry control jog button using your right hand at the same time using your left hand to drive material with handle so as to engage with #1 drive assembly, Jog material approximately two feet. Release jog button. (see pg.6)
8. Jog material thru guillotine using main control start push button.
9. Position selector switch to the run position.
10. Run gutter to desired size.

TRIM CORNERS -REMOVING 3" X 3" OF MATERIAL-
BEFORE FEEDING GUTTER COIL INTO THE MACHINE.

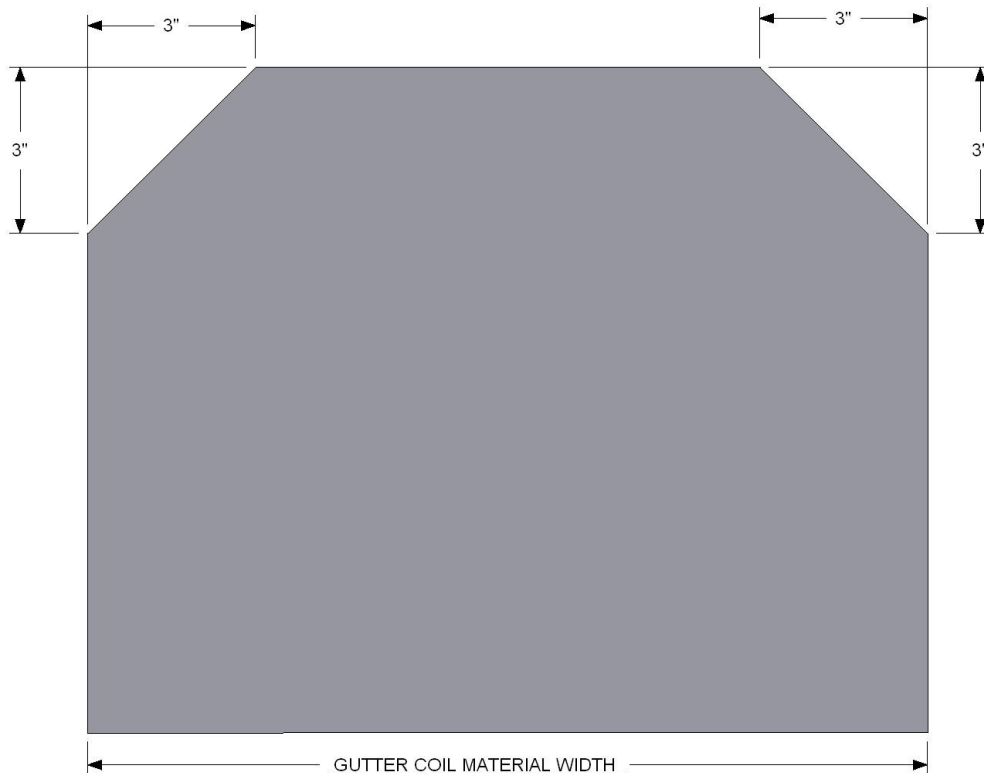

SECTION 15

POLYURETHANE DRIVE SYSTEM

The drive train of this machine is in most circumstances maintenance free.

If a material traction problem arises or a roller is replaced, the top roller is adjustable up and down.

CAUTION: DO NOT OVER TIGHTEN DRIVE ROLLERS

The factory setting for the rollers is 1/4 turn past the point of contact.

The **MAXIMUM** amount of drive pressure recommended is 1/4 turn past factory setting.

ADJUSTING DRIVE SYSTEM TO ADD TRACTION:

Start with top #1 drive assembly;

- 1.) Turn locking nuts (C) counter clockwise; loosening the adjustment bolts (A) at all four places.
- 2.) Turn locking bolt (B) counter clockwise a 1/4 turn to loosen all four bolts.
Only turn the bolts just enough to break them free.
- 3.) Turn adjustment bolts (A) clockwise 1/16 of a turn.
- 4.) Tighten locking bolts (B) 4 places.
- 5.) Tighten locking nuts (C).

Run machine forward, if more traction is needed repeat the above procedure on top #2 drive assembly.

If more traction is still needed repeat above procedure as required on the remaining exit drives.

NOTE: If material slippage occurs after material leaves the #4 drive assembly, add pressure to the exit drive forming assembly (SEE PG. 20-21).

CLEANING OF POLYURETHANE:

Clean outer surface of rollers using soap & water to remove any dirt or debris.

SECTION 16
POLYURETHANE DRIVE SYSTEM
RUBBER DRIVE ASSEMBLY

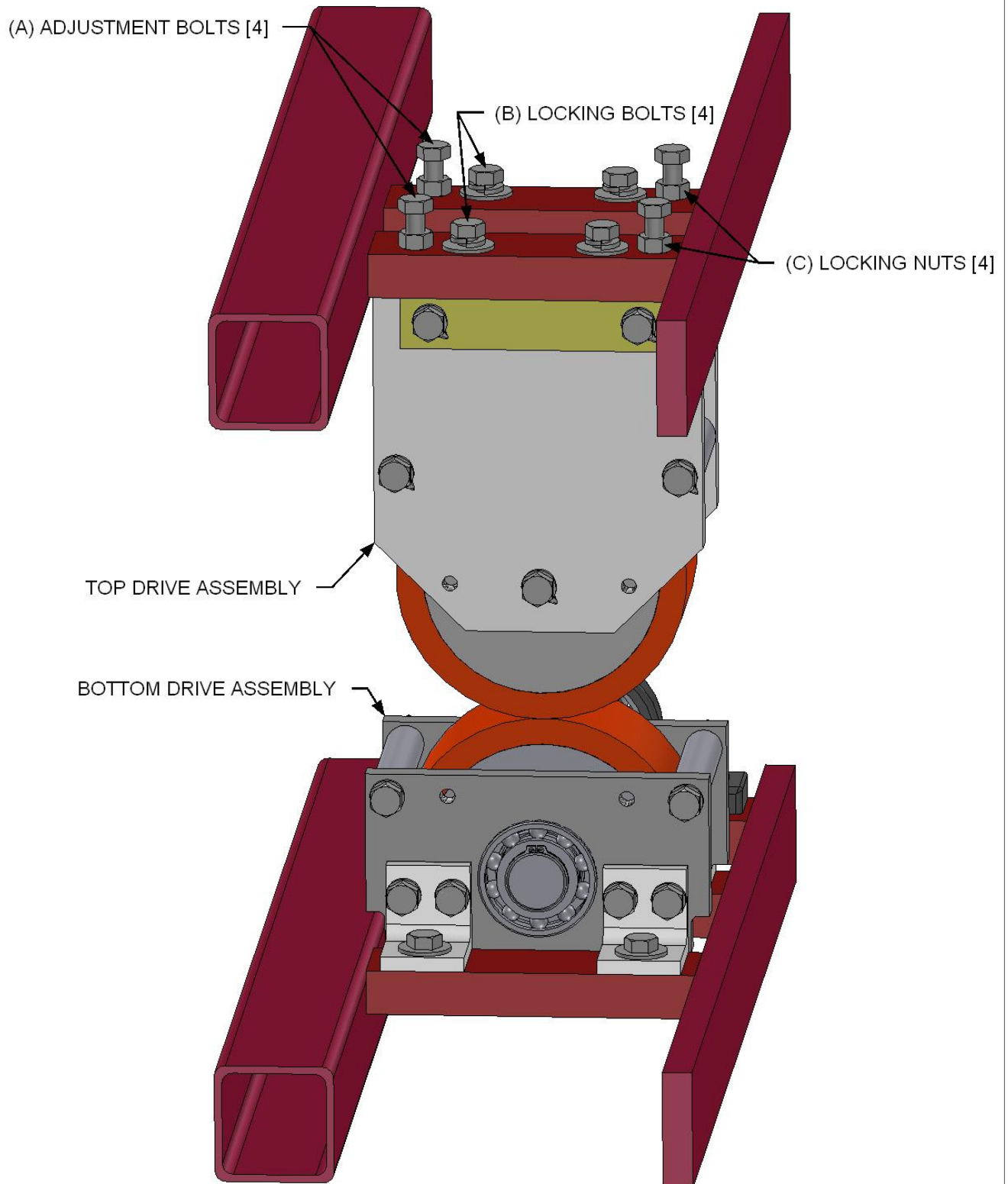

SECTION 17

FORMING COMPONENTS AND ASSEMBLIES

GUIDE BAR COMPONENTS:

- The guide bars are in a fixed positive relative to the forming stations.
- The back guide bar must be in contact with the material at all times.
- The face guide bar supports the face portion of material guiding it into the lip forming box assembly.
- The back guide bar supports the back portion of material through the complete forming process and bends the back bottom corner of the gutter.
- The guide bars are not adjustable components on fascia machines.

GUIDE BAR MAINTENANCE:

- Check guide bars for marks, burrs, or build up that could cause a mark or scratch on gutter.
- To clean guide bars, lightly sand with a fine grit emery cloth & polish out any remaining marks with Scotch Brite.

LIP FORMING BOX

- The lip-forming box consists of seven stations, with #1 being the entrance and #7 being the exit, and three color-coded adjustment areas.

LIP FORMING BOX MAINTENANCE:

- The forming rollers are machined from stainless steel to eliminate corrosion.
- Check rollers for marks, burrs or build up.
- If a roller becomes marked use fine grit emery cloth to remove the mark. Then polish out any remaining marks or scratches with Scotch Brite.

COLOR CODED ADJUSTMENTS

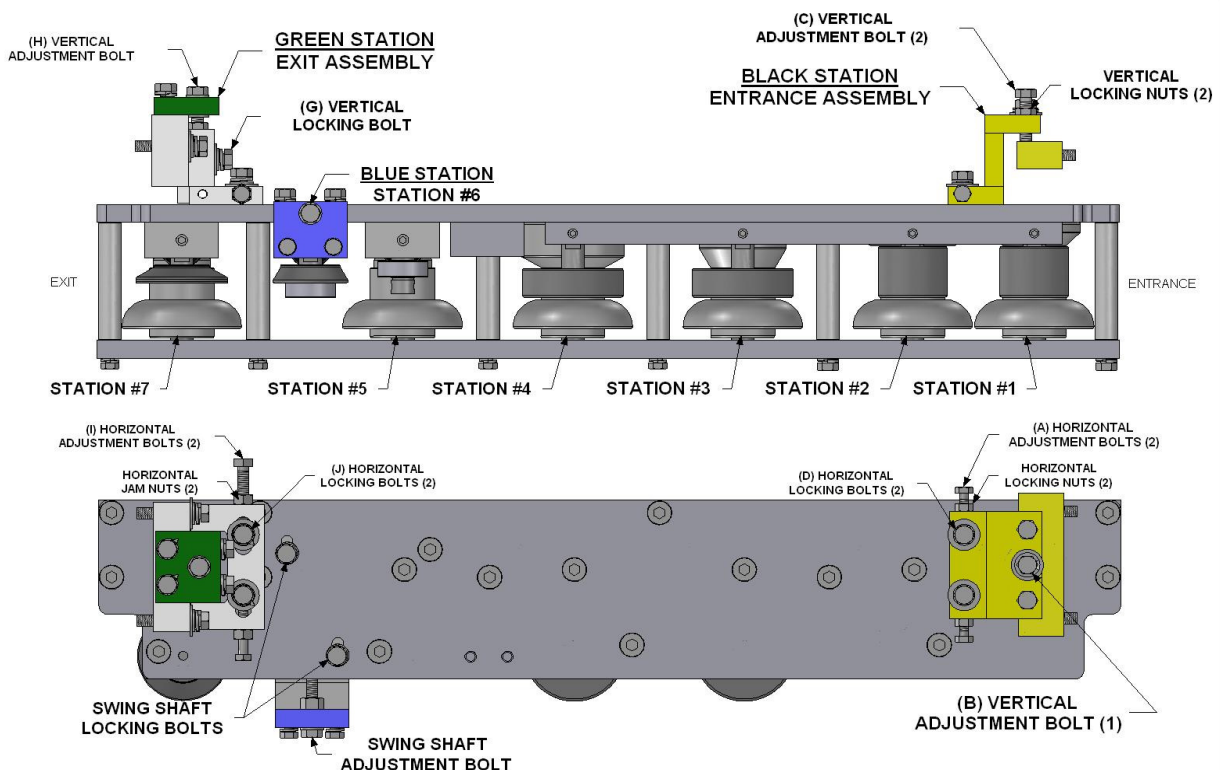

SECTION 18

ADJUSTING LIPBOX ASSEMBLY – ENTRANCE (BLACK)

**THE LOCATIONS OF THE LIPBOX ARE FACTORY SET AND SHOULD NOT BE ALTERED
UNLESS AUTHORIZED**

To raise the lip box assembly – vertical

1. Loosen locking nuts (C) on adjustment bolts (B).
2. Turn locking bolt (A) counter clockwise.
3. Turn adjustment bolts (B) clockwise equally to desired height.
4. Tighten locking bolt (A) and locking nuts (C)

To lower the lip box assembly - vertical

1. Loosen locking nuts (C) on adjustment bolts (B).
2. Turn locking bolt (A) counter clockwise.
3. Turn adjustment bolts (B) counter clockwise equally to desired height.
4. Tighten locking bolt (A) and locking bolts (B).

To move the lip box assembly side to side – lateral

1. Loosen horizontal mounting bolts (F) and locking nuts (E) on adjustment bolts (D)
2. Turn adjustment bolt (D1) clockwise to move the bar towards the center of the machine.
3. Turn adjustment bolt (D2) clockwise to move the bar towards the side of the machine.
4. Tighten locking nuts (E) and horizontal mounting bolts (F)

SEE SECTION 29 FOR SPECIFIC ADJUSTMENT CONDITIONS.

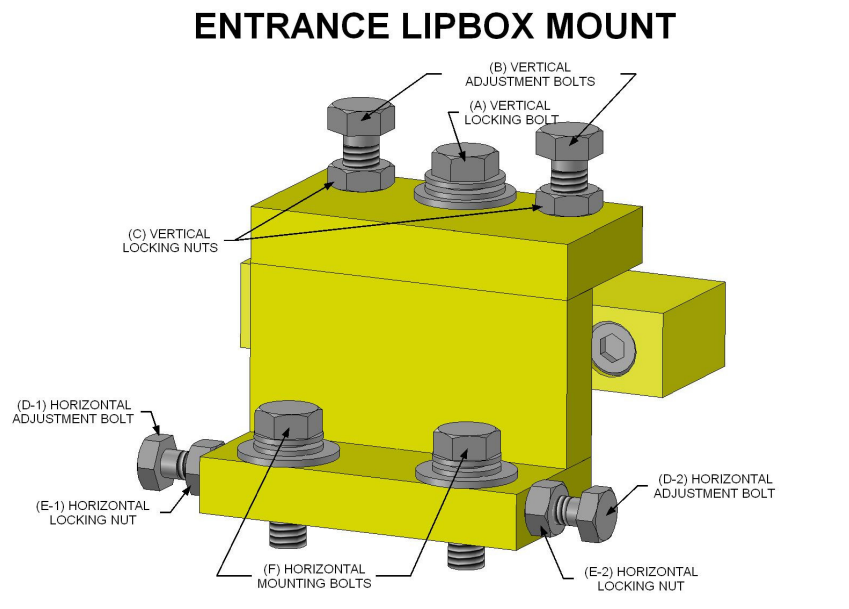

PRECAUTION:

- ❖ THE FORMING BARS ARE A CRITICAL PART OF THIS MACHINE WHEN ADJUSTING IN THIS AREA MOVE ADJUSTMENTS INCREMENTALLY 1/8 OF A TURN AT A TIME.
- ❖ ALWAYS RETURN TO ORIGINAL POSITION BEFORE TRYING A DIFFERENT ADJUSTMENT.
- ❖ DO NOT OVER ADJUST THIS ASSEMBLY.

SECTION 19

ADJUSTING BAR ASSEMBLIES – EXIT (GREEN)

**THE LOCATIONS OF THE LIP BOX ARE FACTORY SET AND SHOULD NOT BE ALTERED
UNLESS AUTHORIZED**

To raise the lip box assembly – vertical

1. Loosen locking nut (I) on adjustment bolt (J).
2. Loosen locking bolts (G) 2 places.
3. Turn adjustment bolts (J) clockwise equally to desired height.
4. Tighten locking bolts (G) and locking nut (I).

To lower the lip box assembly – vertical

1. Loosen locking nut (I) on adjustment bolt (J).
2. Loosen locking bolts (G) 2 places.
3. Turn adjustment bolts (J) counter clockwise to desired height.
4. Tighten locking bolts (G) and locking nut (I).

To move the bar side to side – lateral

1. Loosen locking nuts (L) on adjustment bolts (M) and the horizontal mounting bolts (K)
2. Turn adjustment bolt (M1) clockwise to move the lip box assembly towards the side of the machine.
3. Turn adjustment bolt (M2) clockwise to move the lip box assembly towards the center of the machine.
4. Tighten locking nuts (L) and the horizontal mounting bolts (K)

SEE SECTION 29 FOR SPECIFIC ADJUSTMENT CONDITIONS.

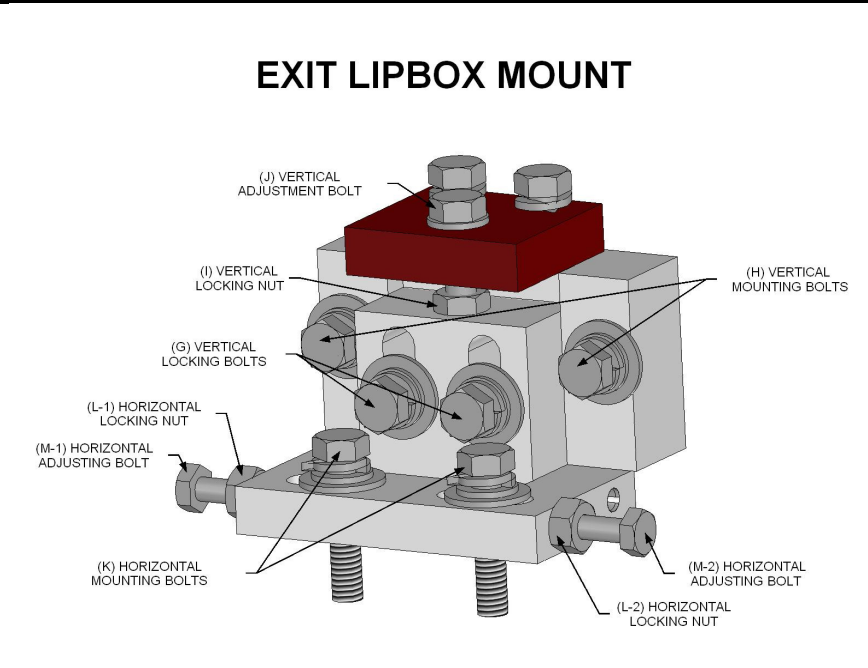

PRECAUTION:

- ❖ THE FORMING BARS ARE A CRITICAL PART OF THIS MACHINE WHEN ADJUSTING IN THIS AREA MOVE ADJUSTMENTS INCREMENTALLY 1/8 OF A TURN AT A TIME.
- ❖ ALWAYS RETURN TO ORIGINAL POSITION BEFORE TRYING A DIFFERENT ADJUSTMENT.
- ❖ DO NOT OVER ADJUST THIS ASSEMBLY.

SECTION 20

ADJUSTING SWING SHAFT STATION (BLUE)

**THE LOCATIONS OF THE LIP BOX ARE FACTORY SET AND SHOULD NOT BE ALTERED
UNLESS AUTHORIZED**

SEE SECTION 29 FOR SPECIFIC ADJUSTMENT CONDITIONS.

To ADD pressure

1. Loosen locking bolts (E) top plate allowing the swing shaft assembly to slide.
2. Turn adjustment bolt (F) clockwise to add pressure to the lip of the gutter
3. Tighten locking nuts. (L)

To RELIEVE pressure

1. Loosen locking bolts (E) top plate allowing the swing shaft assembly to slide.
2. Turn adjustment bolt (F) counter-clockwise to relieve pressure on the lip of the gutter.
3. Tighten locking nuts. (L)

DO NOT OVER ADJUST THIS ASSEMBLY!
**MOVING THE SWING SHAFT PAST ITS RANGE WILL CAUSE
THE OPPOSITE AFFECT TO THE GUTTER.**

PRECAUTION:

- ❖ THE FORMING BARS ARE A CRITICAL PART OF THIS MACHINE WHEN ADJUSTING IN THIS AREA MOVE ADJUSTMENTS INCREMENTALLY 1/8 OF A TURN AT A TIME.
- ❖ ALWAYS RETURN TO ORIGINAL POSITION BEFORE TRYING A DIFFERENT ADJUSTMENT.
- ❖ DO NOT OVER ADJUST THIS ASSEMBLY.

SECTION: 21

EXIT END FORMING AND DRIVE ASSEMBLY

This assembly is a very important part of the machine. Not only does it finish the forming process, but it also drives the material out of the machine.

IRONMAN EXIT DRIVE ASSEMBLY SET UP DIMENSIONS

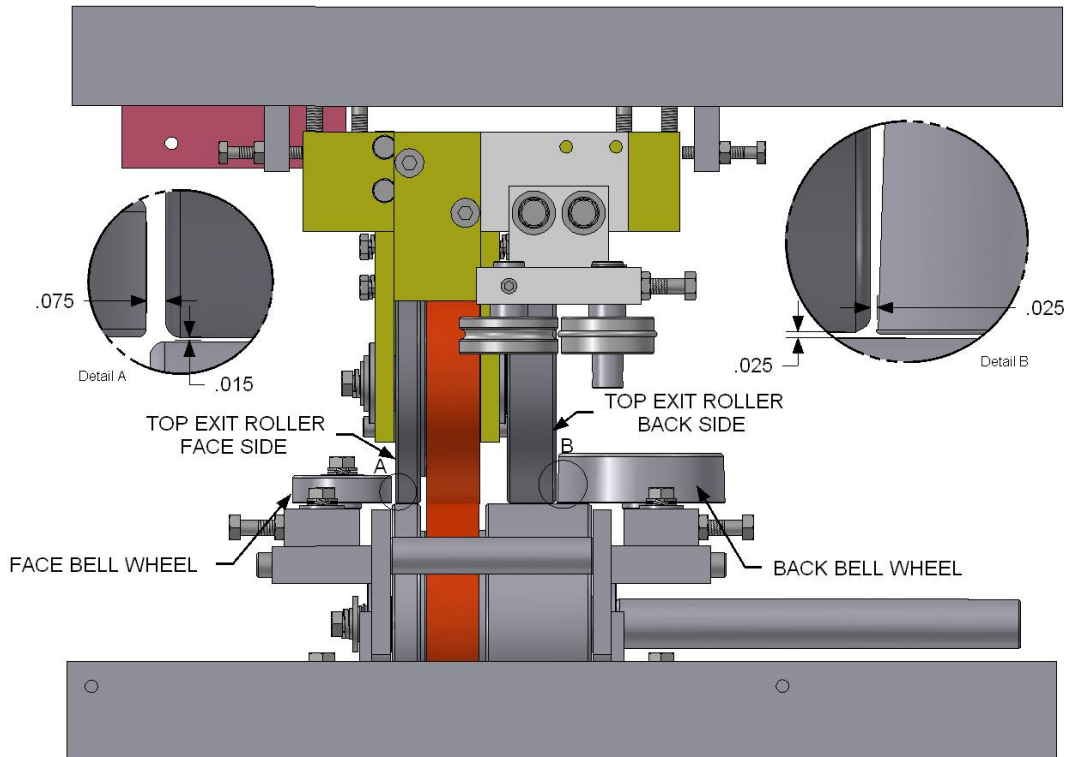

IMPORTANT:

- The #3 SKATE and the EXIT END FORMING DRIVE STATION are bolted together by BOLTS (K) to insure that the drive roller stays square to the skate.
- Before making any adjustment to this assembly, you must loosen BOLTS K (2 places).

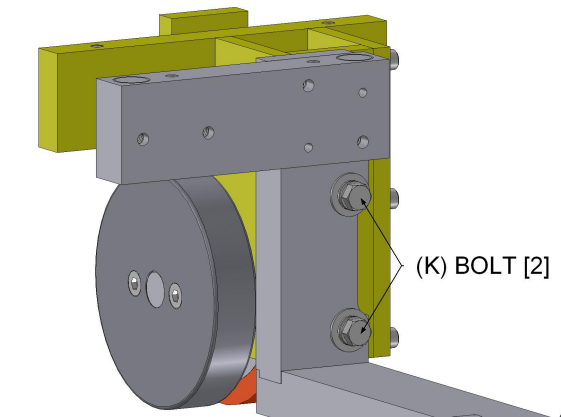

CAUTION: Always make sure BOLTS K is retightened after adjustment.

IRONMAN TOP EXIT DRIVE ADJUSTMENT

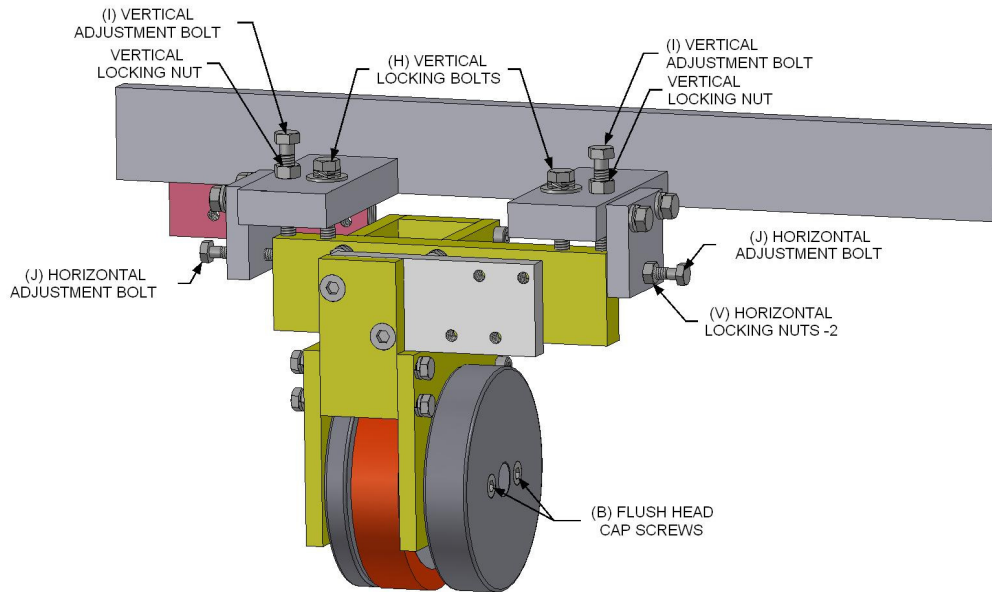

1. FACE-SIDE OF TOP EXIT ROLLER ASSEMBLY:

- This area will control into the house and also up & downhill on the face-side bottom of the gutter.
- This station is very responsive; make small incremental adjustments of less than 1/32 of a turn.

ADJUSTMENT:

1. Loosen HORIZONTAL LOCKNUT (V) on HORIZONTAL ADJUSTMENT BOLT (J).
2. Loosen VERTICAL LOCKING BOLT (H) and the LOCK NUT on VERTICAL ADJUSTMENT BOLT (I).
3. **TO ADD PRESSURE**; turn ADJUSTMENT BOLT (I) clockwise.
 - a. **TO RELIEVE PRESSURE**, turn ADJUSTMENT BOLT (I) counter-clockwise.
4. Tighten LOCKING BOLTS and NUTS

2. BACK SIDE OF TOP EXIT ROLLER:

ADJUSTMENT:

1. Loosen HORIZONTAL LOCKNUT (V) on HORIZONTAL ADJUSTMENT BOLT (J).
2. Loosen VERTICAL LOCKING BOLT (H) and the LOCK NUT on VERTICAL ADJUSTMENT BOLT (I).
3. **TO ADD PRESSURE**; turn ADJUSTMENT BOLT (I) clockwise.
 - a. **TO RELIEVE PRESSURE**, turn ADJUSTMENT BOLT (I) counter-clockwise.
4. Tighten LOCKING BOLTS and NUTS

3. ADDING PRESSURE TO EXIT POLYURETHANE DRIVE ROLLER:

- The top exit roller is very responsive to adjustment; make all adjustments in very small increments.
- DO NOT exceed 1/32 of a turn past factory setting.

ADJUSTMENT: (SEE PG 19)

1. Loosen LOCKNUTS on ADJUSTMENT BOLTS (J), (H), and (I).
2. Loosen LOCKING BOLTS (J) 1/16 of a turn counter-clockwise.
3. **TO ADD PRESSURE**,
 - a. Turn ADJUSTMENT BOLTS (I) equally a 1/64 of a turn clockwise.
Make sure to add pressure equally to both sides.
4. Tighten LOCKING BOLTS and NUTS

SECTION: 22

BELL WHEEL ASSEMBLIES

FACE BELL ROLLER AND BACK BELL ROLLER:

- Adjusting bell rollers will control the squaring of the bottom corners of the gutter, as well as into and away from the house.

ADJUSTMENT

1. Loosen PIVOT BOLT, LOCKING BOLT, and the LOCKNUT on ADJUSTMENT BOLT.
2. **TO MOVE BELL ROLLER CLOSER TO THE TOP DRIVE ASSEMBLY:**
Turn ADJUSTMENT BOLT counter-clockwise (this will allow bell wheel to move towards top roller).
3. **TO MOVE BELL ROLLER AWAY FROM THE TOP DRIVE ASSEMBLY:**
Turn ADJUSTMENT BOLT clockwise to the desired clearance.
4. Tighten PIVOT BOLT, LOCKING BOLT, and LOCKNUT on ADJUSTMENT BOLT.

BELL WHEEL ASSEMBLIES

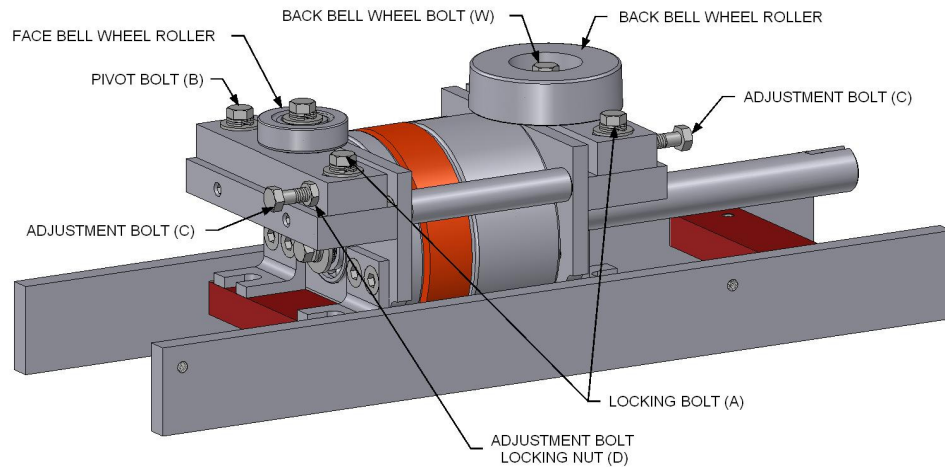

SECTION: 23

BEAD ROLLER ASSEMBLY

The BEAD ROLLER is used to give the back section of the gutter some form and structure. The amount of pressure will also control up & downhill on the back of the gutter.

FACTORY SETTING: VERTICAL height of bead roller is 3/8" down from the top of the back of the gutter; HORIZONTAL position is a 1/32" gap between the material being formed and the back-side of the top exit roller.

BEAD ROLLER ASSEMBLY

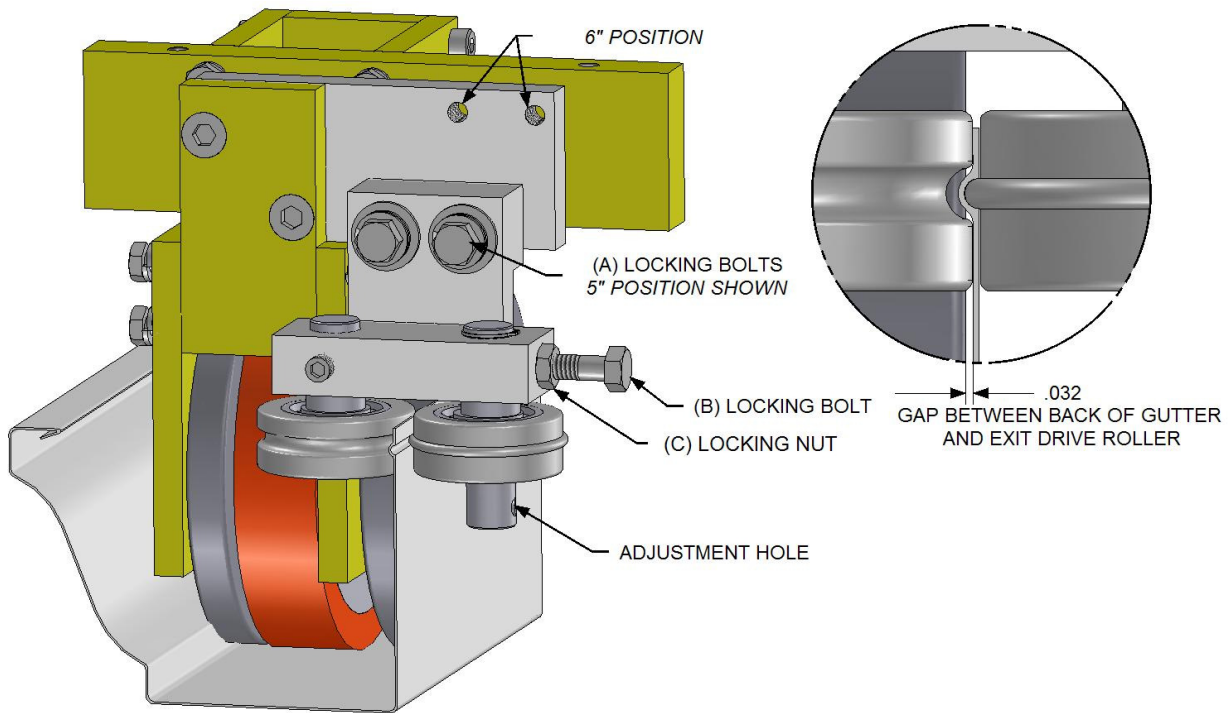

1. BEAD ROLLER ADJUSTMENT:

- Loosen BOLTS A (2 places) to align bead roller assembly, and retighten after alignment is made.
- TO INCREASE OR DECREASE PRESSURE** to bead itself, loosen LOCKING NUT C and LOCKING BOLT B, and turn eccentric shaft using a 3/16 Allen wrench in the adjustment hole to desired spacing.
- Adding too much pressure to the bead will cause the back of the gutter to run uphill. If this happens, simply relieve pressure from bead and retighten LOCKING BOLT and LOCKING NUT.

SECTION 24

GUILLOTINE AND FACE PLATE ASSEMBLY

The guillotine assembly is machined to very tight tolerance, requiring that it be maintained on a regular basis. If the guillotine assembly is kept clean, lubricated and all hardware tight, you can expect trouble free performance for years to come.

DAILY MAINTENANCE:

Lubricate GUILLOTINE blade using 20 or 30-weight oil.

ADJUSTING GUILLOTINE POSITION. (see pg. 25)

The guillotine is moveable in all directions.

To Raise Guillotine

1. Loosen locking bolts (C) - 6 places
2. Loosen locking nuts (A) on adjustment bolts (B) - 2 places
3. Turn adjustment bolts (B) - 2 places clockwise
4. After desired position is acquired, tighten locking bolts (C) 6 places
5. Tighten locking nuts (A) on adjustment bolts (B) 2 places.

To Lower Guillotine

1. Loosen locking bolts (C) - 6 places
2. Loosen locking nuts (A) on adjustment bolts (B) - 2 places
3. Turn adjustment bolts (B) - 2 places counter clockwise
4. After desired position is acquired, tighten locking bolts (C) 6 places
5. Tighten locking nuts (A) on adjustment bolts (B) 2 places.

To move guillotine side to side

1. Loosen locking bolts (D) – 4 places.
2. After desired position is acquired, tighten locking bolts (D) – 4 places

SECTION 25

GUILLOTINE AND FACE PLATE ASSEMBLY DRAWINGS

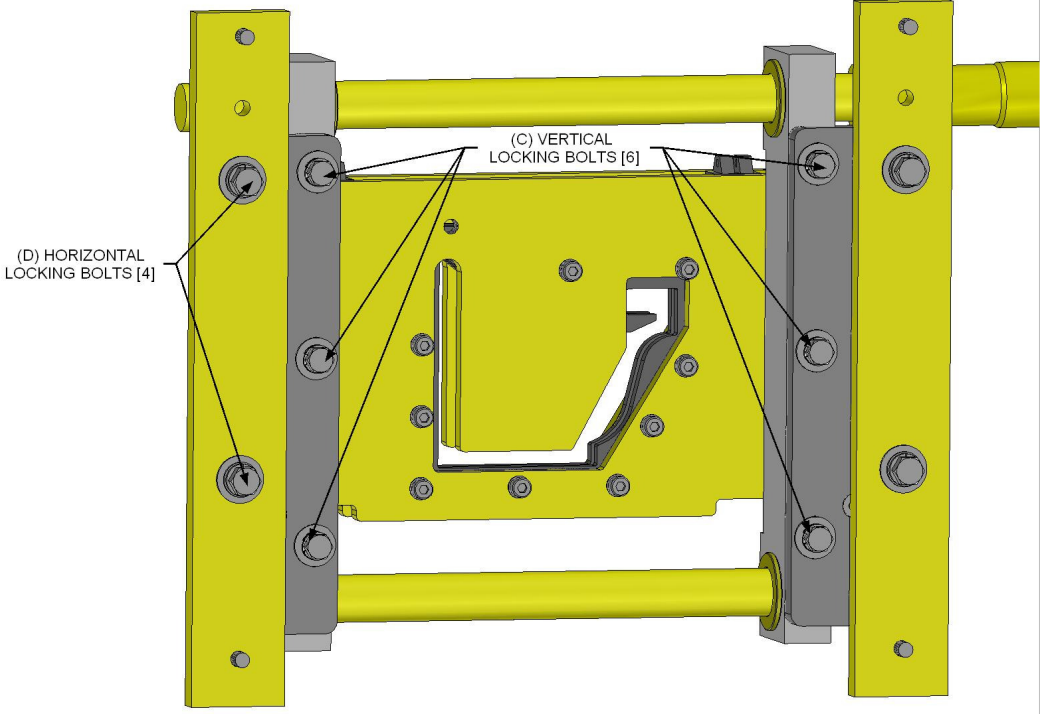
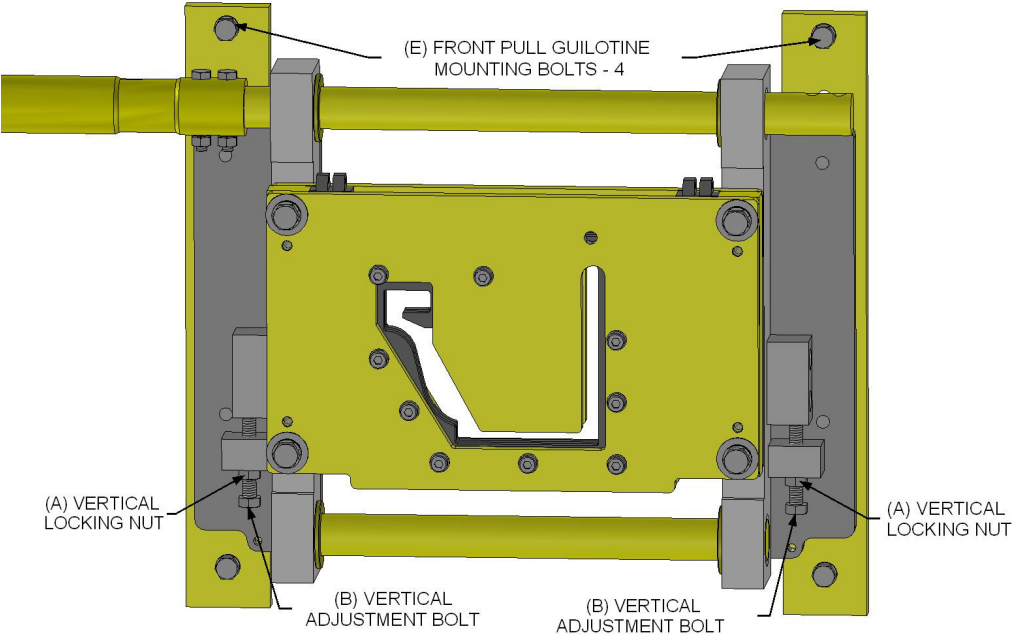

SECTION: 26

MACHINE OPERATION RECAP AND SUMMARY

This section is only a brief summary. Please read the entire manual prior to operation.

ORDER OF OPERATION:

1. Connect the machine to the proper power source using the proper extension cord.
2. Position the selector switches to the JOG position and the FORWARD position.
3. Loosen thumbnuts, removing pressure on the spool brakes from the spool that you have selected to run.
4. Trim both corners of the coil at a 45-degree angle approximately 3" in from edges. Insert trimmed coil into the entrance guide system, making sure that coil is snug to both sides with free front to back movement.
5. With the material positioned in the entrance guides, grasp the material with one hand, reach around to the right side of the machine, and press the JOG button while pushing the material until it engages the #1 drive assembly. With the material moving forward under its own power, release JOG button.
6. Using the green start button at the main operator's panel, advance the material through the guillotine approximately 12", and then cut off the 12" section of gutter.
7. The selector switches can be used for FORWARD/REVERSE and JOG/RUN operation of the machine once machine is fed. Set the selector switch to run mode. By depressing START button, machine will run continuously. Depress red button to stop machine.
8. Jog gutter to desired length and cut off using guillotine. Run out support stands must be used to support gutter after 8'.
9. Prior to the completion of the last piece of gutter being produced, cut the coil stock before the entrance guides to clear machine. The Fascia machine should be empty when transporting from job to job.

SECTION: 27 ANALYZING GUTTER

STEP #1: Feed the machine with the material (through entire machine).

STEP #2: Run gutter through the guillotine approximately 12”.

STEP #3: Back gutter up 3”.

STEP #4: Visually check POINTS for double track. (SEE BELOW)

- A double track is a misalignment of stations; with the gutter backed up, it will show as two lines or a double line.
- A double track located on POINTS 5 & 6 are formed by the skate assemblies.
- A double track on POINT 4 is controlled by the vertical adjustment of the entrance end of the lip box.

STEP #6: Measure top width of the gutter from POINT 3 to POINT 8. (SEE PG. 42)

- The correct width measurement is approximately 5” (+/- 1/8”).
- The width of the top of the gutter is controlled by the exit end of the box, GREEN station, and the bell rollers
- Prior to measuring the top of the gutter, make sure that the back of the gutter is square to the bottom at POINT 6.

STEP #7: With no double tracks, proper amount of metal in forming box, and the correct width across the top of the gutter, you are now ready to make some corrective adjustments to the machine.

FASCIA GUTTER PROFILE

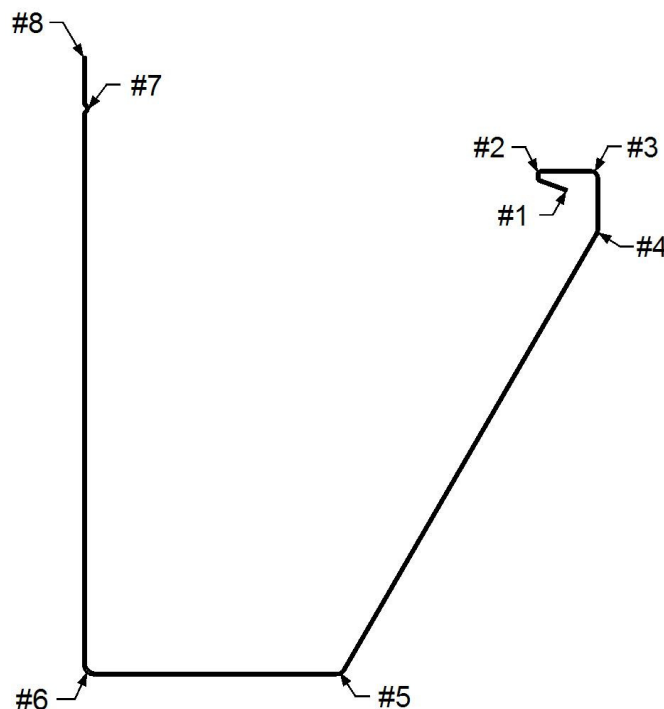

SECTION 28 **GUTTER TALK**

The following are common terms to describe the condition of the gutter.

RUNNING UPHILL

This term describes a condition where the ends of the gutter are higher along the fascia board than the center.

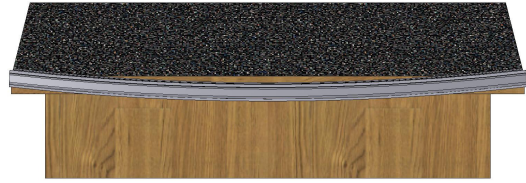

GUTTER RUNNING UPHILL

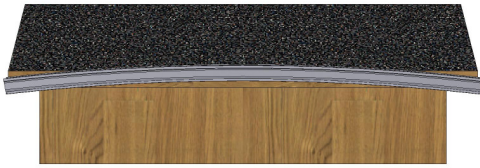

GUTTER RUNNING DOWNHILL

RUNNING DOWNHILL

This term describes a condition where the ends of the gutter are higher along the fascia board than the center.



GUTTER RUNNING INTO THE HOUSE

INTO THE HOUSE

This term describes a condition where the ends of the gutter are closer to the fascia board than the center. Looking from the machine the gutter has a left hand curve.



GUTTER RUNNING AWAY FROM THE HOUSE

AWAY FROM THE HOUSE

This term describes a condition where the center of the gutter is closer to the fascia board than the ends. Looking from the machine the gutter has a right hand curve.



GUTTER LIP RUNNING INTO THE HOUSE

TOP LIP INTO THE HOUSE

This term describes a condition where the end of the top lip is closer to the fascia board than the middle.



GUTTER LIP RUNNING AWAY FROM THE HOUSE

TOP LIP AWAY FROM THE HOUSE

This term describes a condition where the end of the top lip is further away from the fascia than the middle.

SECTION 29

TROUBLE SHOOTING

I. ADJUSTING THE TOP LIP OF GUTTER

The two conditions listed below will be corrected using the **SWING SHAFT (BLUE station)**.
(SEE SWING SHAFT ASSEMBLY PG. 17)

- a. Top lip lines #3 & #4 are running **DOWN** and **AWAY** from the fascia. (SEE PG. 27-28)
The bottom lines #5 & #6 are **STRAIGHT** and **PARALLEL** to the fascia board and are satisfactory.
- b. Top lip lines #3 & #4 are running **UP** and **INTO** the fascia. (SEE PG. 27-28)
The bottom lines #5 & #6 are **STRAIGHT** and **PARALLEL** to the fascia board and are satisfactory.

**** CAUTION: Over-adjustment will cause *OPPOSITE* reaction. ****

- a. To correct for **DOWN and AWAY** from fascia: Add pressure to the SWING SHAFT.
 1. Turn LOCKING BOLT E counter-clockwise to loosen (2 places).
 2. Turn ADJUSTMENT BOLT F clockwise to tighten 1/16 of a turn per adjustment.
 3. Re-tighten LOCKING BOLT E (2 places) (SEE PG. 17).
- b. To correct for **UP and INTO** the fascia: Relieve pressure from the SWING SHAFT.
 1. Turn LOCKING BOLT E counter-clockwise to loosen (2 places).
 2. Turn ADJUSTMENT BOLT F counter-clockwise to loosen 1/16 of a turn per adjustment.
 3. Retighten LOCKING BOLT E (SEE PG.17).

NOTE: After adjustment is made, run an 8' section of gutter to inspect it. If more adjustment is needed, repeat procedure.

NOTE: Adjusting SWING SHAFT will not increase or decrease the amount of lip.

NOTE: The SWING SHAFT should not be used to try and change the size of the hanger lip.

II. ADJUSTING THE BOTTOM PORTION OF GUTTER

The two conditions listed below will be corrected using the **EXIT-END BOX MOUNT (GREEN station)**.
(SEE EXIT BOX MOUNT ASSEMBLY PG. 19)

- a. The whole gutter is running **DOWN and AWAY** from the fascia board. (SEE PG. 27-28)
The top lip lines #3 & #4 are **PARALLEL** to lines #5 & #6 of the bottom.
- b. The whole gutter is running **UP and INTO** the fascia board. (SEE PG. 27-28).
The top lip lines #3 & #4 are **PARALLEL** to lines 5 & #6 of the bottom.

**** CAUTION: Over-adjustment will cause *OPPOSITE* reaction. ****

- a. To correct for **DOWN and AWAY** from the fascia board: Move exit mount of the box downward.
 1. Turn LOCKING BOLT G counter-clockwise to loosen.
 2. Turn ADJUSTMENT BOLT H counter-clockwise 1/16 of a turn per adjustment.
 3. Retighten LOCKING BOLT G.
- b. To correct for **UP & INTO** the fascia board: Move exit mount of the box upward.
 1. Turn LOCKING BOLT G counter-clockwise to loosen.
 2. Turn ADJUSTMENT BOLT H clockwise 1/16 of a turn per adjustment.
 3. Retighten LOCKING BOLT G.

❖ **Use #3 DRIVE FORMING ROLLER and SWING SHAFT ASSEMBLY as a secondary option to acquire the same results. (SEE PG. 21)**

NOTE: Loosen LOCKING BOLT K prior to adjusting the top #3 DRIVE FORMING ASSEMBLY.

**** CAUTION: Over-adjustment will cause OPPOSITE reaction. ****

- A.) **To correct for DOWN and AWAY from the fascia board:**
Add pressure to the face side of the top #3 DRIVE FORMING ROLLER.
- i. Turn locknut on ADJUSTMENT BOLT I counter-clockwise to loosen.
 - ii. Turn ADJUSTMENT BOLT I clockwise 1/64 of a turn.
 - iii. Add pressure to the SWING SHAFT (BLUE station).
 - iv. Turn LOCKING BOLT E (2 places) counter-clockwise to loosen.
 - v. Turn ADJUSTMENT BOLT F clockwise 1/64 of a turn.
 - vi. Retighten all locking bolts/nuts.
- B.) **To correct for UP and INTO the fascia board:**
Relieve pressure from the face side of the top #3 DRIVE FORMING ROLLER.
- i. Turn locknut on ADJUSTMENT BOLT I counter-clockwise to loosen.
 - ii. Turn ADJUSTMENT BOLT I counter-clockwise 1/64 of a turn.
 - iii. Relieve pressure to the SWING SHAFT (BLUE station).
 - iv. Turn LOCKING BOLTS E clockwise to loosen.
 - v. Turn ADJUSTMENT BOLT F counter-clockwise 1/64 of a turn.
 - vi. Retighten all locking bolts/nuts.

➤ **NOTE:** After adjustment is made, run an 8' section of gutter to inspect. If more adjustment is needed, repeat procedure.

III. **ADJUSTING THE WIDTH OF THE GUTTER**

If gutter is too wide or narrow between lines #3 and #8: (SEE PG. 27)

Check line #5 for being at a 60-degree angle to the bottom. (SEE PG. 27)

- A.) **If less than a 60-degree angle is present:** Add pressure to FACE bell wheel.
- i. Turn LOCKING BOLT A and PIVOT BOLT B counter-clockwise to loosen.
 - ii. Turn ADJUSTMENT BOLT B clockwise a 1/16 of a turn.
- B.) **If more than a 60-degree angle is present:** Relieve pressure to bell wheel.
- i. Turn LOCKING BOLT A and PIVOT BOLT B counter-clockwise to loosen.
 - ii. Turning ADJUSTMENT BOLT B counter-clockwise a 1/16 of a turn.

If #5 and #6 are square to the bottom and the gutter is too wide or narrow. (SEE PG. 27)

- A.) **If gutter is too wide:** Move **EXIT BOX MOUNT** towards the back of gutter.
- i. Loosen MOUNTING BOLTS (K)
 - ii. Loosen LOCKING NUT (L-2)
 - iii. Turn ADJUSTMENT BOLT (M-2) clockwise 1/16 of a turn.
 - iv. Tighten MOUNTING BOLTS (K) and LOCKING NUT (L-2)
- B.) **If gutter is too narrow:** Move **EXIT BOX MOUNT** away from the back of gutter.
- i. Loosen MOUNTING BOLTS (K)
 - ii. Loosen LOCKING NUT (L-1)
 - iii. Turn ADJUSTMENT BOLT (M-1) clockwise 1/16 of a turn.
 - iv. Tighten MOUNTING BOLTS (K) and LOCKING NUT (L-1)

➤ **NOTE:** After adjustment is made, run an 8' section of gutter to inspect. If more adjustment is needed, repeat procedure.

IV. CONTINUOUS MARKS OR SCRATCHES

- ❖ Check for interference with shear.
- ❖ Inspect guide rods for imperfections.

V. MATERIAL SLIPPING: (MACHINE NOT PULLING MATERIAL THROUGH)

- ❖ Check the pressure on the spool shaft that is in use from the upright brakes.
- ❖ Check that the entrance guides are not too tight or restricting the material.
 - i. If the guides are correct and the spools are unlocked, add pressure to the #1 & #2 drive assemblies (SEE PG. 15, SECTION 14).
 - ii. When metal slippage occurs while clearing machine and after metal is past the #2 drive, add equal pressure to the #3 DRIVE FORMING ROLLER (SEE PG. 21).

VI. OIL CANNING OR RIPPLING ON BOTTOM

- ❖ An imperfect bottom on the gutter is very uncommon from the IRONMAN.
 - i. Check all bottom rollers, drive rollers, and skate rollers for tape, debris, or buildup. Make sure top drive rollers are not past factory tolerance.

SECTION 30
GUTTER PROFILES

FACIA GUTTER with WING
15" METAL

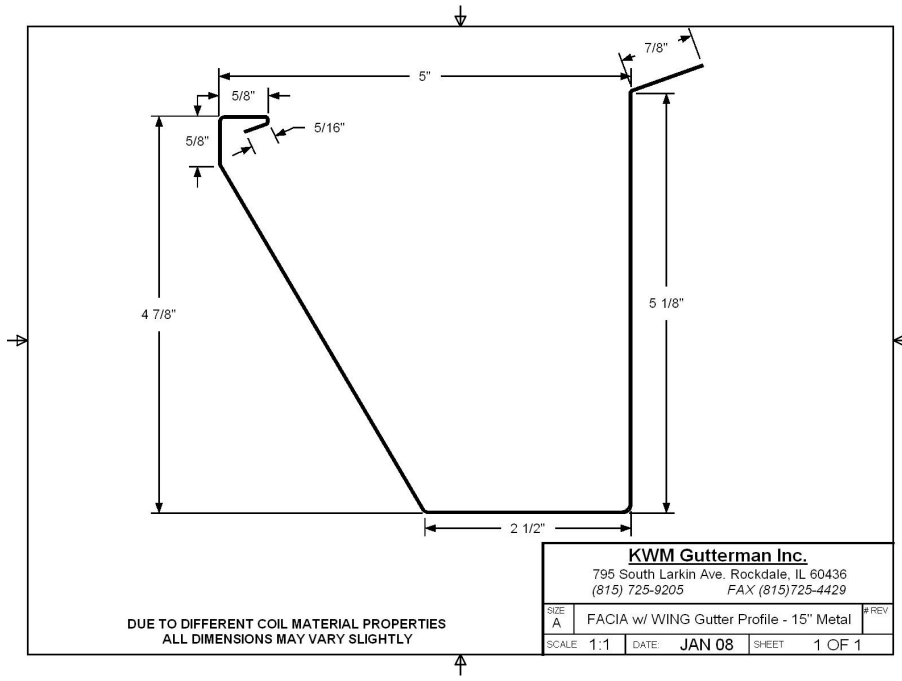
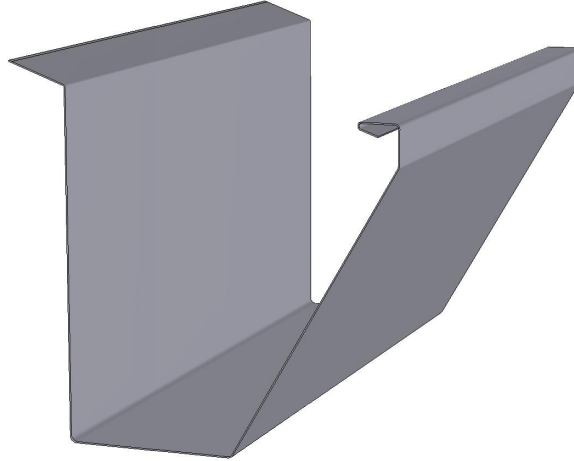

DUE TO DIFFERENT COIL MATERIAL PROPERTIES
ALL DIMENSIONS MAY VARY SLIGHTLY