



Product Data & Installation Guide

1. Product Description

FireMaster® FastWrap XL is a flexible blanket composed of high temperature fibers classified for applications to 2192°F (1200°C) and fully encapsulated in a durable glass fiber reinforced foil facing for easy handling and installation. FastWrap XL is UL Classified and ULC Listed in various systems for 1 and 2 hour fire resistive enclosure protection, reduced clearance for kitchen exhaust ducts, electrical circuit protection, and as a component in various UL firestop designs for fire resistance rated floors, ceilings, and walls. The core fibers in FastWrap XL are manufactured using Thermal Ceramics patented Superwool® fiber which is an alkaline-earth silicate wool with low biopersistence and therefore increased safety for installers. FastWrap XL is under UL's Follow-Up Service Program to ensure the consistent quality essential to this life-safety application.

Product Features

- Zero clearance to combustibles at any location
- Thin and Lightweight at 1-1/2" (38mm) thick, 6 pcf (96 kg/m³) density
- Contours easily to complex duct designs
- Optimized installation with inside layer butt joints on grease duct enclosures per ASTM E 2336
- Fully foil encapsulated for fast and clean installation
- Completely inorganic and non-combustible
- Contains 2192°F (1200°C) rated fibers for added safety margin
- Wide variety of through penetration firestop systems
- Resistant to mold growth
- Good sound absorption

2. Applications

- 1 and 2 hour enclosure and firestop system for kitchen exhaust ducts
- Zero clearance from enclosure to combustibles for kitchen exhaust ducts
- 1 and 2 hour enclosure and firestop system for hazardous exhaust ducts, pressurization ducts, clothes dryer exhaust ducts, trash and linen chutes, and other fire rated HVAC ducts
- 1 hour circuit integrity protection for cable trays and steel conduits
- Engineered solutions and tested systems for fire protection of structural steel beams and columns, and storage vessels per ASTM E119, ISO 834, and UL1709

3. Physical Characteristics

Product	Unit	Size	Units/Ctn.	Wt./Ctn.
FastWrap XL	Roll	1-1/2" x 24" x 25'	1	37.5 lbs.
FastWrap XL	Roll	1-1/2" x 48" x 25'	1	75 lbs.
FastWrap XL Collar	Roll	1-1/2" x 6" x 25'	4	37.5 lbs.
Color	White blanket with silver foil encapsulation			

4. Performance Specifications

Reference Standard	Standard No.	Performance
Grease Duct Enclosure System	ASTM E2336	Pass
Section 16.1 - Non-Combustibility	ASTM E136	Pass
Section 16.2-Fire Resistance (wall)	ASTM E119	Pass
Section 16.3 - Durability Test	ASTM C518	Pass
Section 16.4 - Internal Fire Test	ASTM E2336	Pass
Section 16.5 - Fire Engulfment (duct)	ASTM E814/E119	Pass
ULC Grease Duct Test Protocol		Pass
Grease Duct Clearances	UL 1978	Pass
Air Ventilation Duct Enclosure	ISO 6944	Pass
Surface Burning Characteristics		
Flame Spread (foil/blanket)	ASTM E84	5/0
Smoke Developed (foil/blanket)	ASTM E84	10/0
Thermal Resistance (R-value @ 70°F)	ASTM C518	7.3 per layer
Mold Growth (75% -95% humidity)	ASTM D6329	Resistant

5. Listings/Building Code Reports

Listed Uses	Agency	Listing	Layers
Grease Duct Enclosure per ASTM E2336 and AC101	UL	G18	2
	ICC-ES	ESR 2213	
Grease Duct Insulation per ULC Grease Duct Insulation Test Protocol	ULC	FRD 4, 7	2
Grease Duct Insulation (2003 IMC)	OPL	TC/BI 120-01	1
Through Penetration FireStop System per ASTM E814, UL 1479	UL	See Figure 2	1 or 2
	ULC		
Ventilation Duct Enclosure System per ISO 6944-1985	UL	HNLJ.V1, 2, 3, 4, 11, 12, 19	1
	ULC	FRD 3, 5, 6, 18	
Electrical Circuit Protective System	UL	FHIT.5	2

6. Storage

FastWrap XL must be stored in a dry warehouse environment on pallets. Pallets should not be stacked.

7. Installation

FastWrap XL shall be installed by a qualified contractor in accordance with manufacturer's instructions and design listings. See figures 1 to 5 for complete details.

Materials and Equipment

- FastWrap XL blanket
- Aluminum foil tape
- Glass filament reinforced tape (optional)
- Carbon steel or stainless steel banding material, minimum 1/2" (13mm) wide, minimum 0.015" (0.4mm) thick, with steel banding clips
- Hand banding tensioner and crimping tool
- Minimum 12 gage (3mm) steel insulation pins; steel speed clips, minimum 1-1/2" (38mm) square or 1-1/2" (38mm) diameter, or equivalent sized cup-head pins;
- Capacitor discharge stud gun
- FireMaster F2-HT-XL3 Prefabricated Door or Field Fabricated Door Hardware
- An approved firestop sealant

General

To minimize waste, FastWrap XL blanket should be rolled out tautly before measuring. Cut edges of the blanket shall be taped with aluminum foil tape to prevent exposed edges of the insulation absorbing grease and moisture in the event of a compromised grease duct joint. Overlaps are used to block heat transfer in the event of duct deformation resulting from thermal expansion. Filament tape is suggested to temporarily hold the blanket in place until steel banding or pinning is installed to permanently secure the blanket.

A. First Layer / Single Layer Installation

1) Butt Joint for ASTM E2336 compliant grease duct enclosure (Figure 1) - The first layer of FastWrap XL is cut to completely wrap around the perimeter of the duct with enough excess to provide a tight butt joint where the blanket ends meet. The joints of adjacent blankets are firmly butted against each other.

2) Overlaps required for ISO 6944 compliant single layer air ventilation duct enclosure and two layer grease duct enclosures installed in Canada (Figure 1) - The layer of FastWrap XL applied directly to the duct is cut to completely wrap around the perimeter of the duct with enough excess to overlap itself by a minimum of 3" (75mm). The joints of adjacent blankets must overlap each other by a minimum 3" (75mm).

B. Second Layer Where Required – (Figure 1)

The second layer of FastWrap XL is cut to completely wrap around the perimeter of the first layer, with enough excess to overlap itself not less than 3" (75mm). Joints in the second layer should be staggered a minimum of 6" (50mm) from joints on the inner layer. Adjacent blankets on the second layer must overlap each other by not less than 3" (75mm). As an alternative to overlaps on adjacent blankets installed on the second layer, adjacent blankets can be tightly butt jointed and wrapped with a 6" (152mm) wide FastWrap XL collar centered over the butt joint.

C. 2 & 3 Sided Wrap Installation (Figure 5)

When space does not allow for a complete wrap applied to the duct on all four sides, the FastWrap XL is approved for 2 or 3 sided installations with mechanical attachment to a rated concrete or CMU assembly. The FastWrap XL is installed on the 2

or 3 sides of the duct as described in one of the installation methods described in sections A or B with the starting edge of the blanket attached to the concrete or CMU assembly and then wrapped around the duct until the other end can be attached to the other concrete or CMU assembly, thus encapsulating the duct with insulation around all accessible sides. The blanket is to flange out onto the concrete or CMU assembly. It shall be secured to the adjoining assembly with min 3/16" (5mm) diameter, 4" (102mm) long concrete anchors, footed to a minimum 1-1/2" (38mm) wide x 3/16" (5mm) thick steel strip/strap with pre-drilled holes spaced a maximum 10" (254mm) on center. The steel strip is to be placed around the entire perimeter of the duct in the exposure area. The FastWrap XL insulation wrap is secured to the duct with minimum 1/2" (13mm) wide steel banding 10-1/2" (270mm) centers. The ends of the banding are to loop into and around the steel strips/straps that foot the blanket to the concrete floor or wall, and tightened down.

D. Mechanical Attachment Methods for Insulation Wrap

1) Banding (Figure 1) - Minimum 1/2" (13mm) wide carbon steel or stainless steel banding, 0.015" (0.4mm) thick, is placed around the entire perimeter of the insulated duct on maximum 10-1/2" (270mm) centers and 1-1/2" (38mm) from each blanket edge or 1-1/2" (38mm) from each collar edge when using the butt joint and collar method. When banding, filament tape can be used to temporarily hold the blanket in place until the banding is applied. The banding is placed around the blanket and tightened to firmly hold the FastWrap XL in place against the duct, but not cause any cutting or damage to the blanket.

2) Pinning (Figure 4) - If the pin pattern shown in Figure 4 is used on all faces of the duct, then 12 Gage (0.4mm) insulation pins may be used in lieu of steel banding. To prevent blanket sag, 12 Gage (0.4mm) pins installed as shown in Figure 4 are required in addition to banding on the bottom of horizontal ducts where the bottom dimension is larger than 24" (610mm), or on one side of vertical ducts where one dimension is larger than 24" (610mm). Pins that extend beyond the outer blanket layer shall be turned down or the excessive length cut off to prevent sharp edges. Shoot through pins (cup head pins) may be used in conjunction with steel banding to prevent blanket sag.

E. Field Fabricated Access Doors

1) Field Fabricated Access Doors (Figure 3) - Each access door assembly has four threaded rods 1/4 inch (6mm) in diameter and 5" (127mm) in length, with one welded to each corner of the door opening. Hollow steel tubes, 4-1/2" (114mm) long are installed outside the access cover plate and over the threaded rods. Four 12 gage (3mm) and 4-1/2" (114mm) long steel insulation pins are welded to the access cover plate to allow for installation of the three layers of FastWrap XL. One layer of FastWrap XL is cut to approximately the same size as the access panel, and impaled over the insulation pins on the panel. A second layer of FastWrap XL is cut so as to overlap the first layer a minimum of 1-1/2" (38mm). It is essential that the first and second layer fit tightly against the surrounding wrap with no through openings. The third and outside layer should be cut to overlap the second insulation layer by a minimum of 1-1/2" (38mm). Minimum 1-1/2" (38mm) round or square insulation clips are installed on the insulation pins to secure the three layers of insulation to the access cover plate. All cut edges of the insulation shall be taped with minimum 3" (75mm) wide aluminum foil tape. Wing nuts and washers are installed on the four threaded rods, and tightened

against the hollow steel tubes to seal the access cover plate to the duct.

2) Field Insulated DuctMate Access Doors (Figure 3) – DuctMate Ultimate and F2 doors are approved for use with FastWrap XL, and shall be installed according to DuctMate Industries installation instructions. A 16 gage (1.4mm) outer cover plate is required, which is 6” (152mm) larger in width and length than the DuctMate door, and which has holes drilled to match the threaded rods on the DuctMate door. Four 12 gage (3mm) insulation pins are welded to this outer cover plate, and three layers of FastWrap XL are impaled and fastened using minimum 1-1/2” (38mm) insulation clips. The insulation layer adjacent to the DuctMate door is cut to the size of the door and each successive layer has an overlap of 1-1/2” (38mm) over the adjacent layer. It is essential that the first and second layer fit tightly against the surrounding wrap with no through openings. All edges of insulation blanket must be sealed with minimum 3” (75mm) wide aluminum foil tape. The insulated cover plate is installed over the Ductmate threaded rods, and held tight against the duct with wing nuts and washers.

3) FireMaster Factory Built Access Doors (Figure 3) – FireMaster doors are tested per ASTM E2336 and are intended for use in two layer installations. FireMaster access doors come complete and ready for installation with a DuctMate® F2 access door, cut-out template, an outside cover plate with proper signage, an as tested FastWrap XL insulation package, and installation instructions.

F. Through Penetration Firestop System (Figure 2) - When the duct penetrates a fire rated assembly an approved fire stop system must be employed. Figure 2 provides a complete list of UL / ULC firestop design listings which can be found in the Certifications Directory at www.ul.com for US systems and www.ulc.ca for Canadian systems. Prior to installing any firestop system the surfaces of all openings and penetrating items must be clean and dry. The FastWrap XL core blanket (or mineral wool where allowed by the firestop design listing) must be compressed into the annular space. The packing material must be recessed a minimum depth from the surface of the concrete or gypsum assembly. The recessed opening must be filled with a minimum thickness of an approved firestop sealant. The packing material type and compression, minimum recess (typically 1/4” (6mm)), and approved firestop sealant and thickness (typically 1/4” (6mm)) shall be as specified in an approved UL / ULC firestop design listing. When there is not sufficient annular space around the duct to run the FastWrap XL enclosure system continuous through the fire rated assembly, the enclosure may terminate above and below the floor/ceiling assembly or on either side of a wall assembly as shown in Figure 2. When this method is used, the FastWrap XL must be mechanically attached on either side of the fire rated assembly using one of the attachment methods described in Section D, spaced a maximum of 1-1/2” (38mm) from the fire rated assembly.

G. Support Hanger Systems

1) Grease ducts: Trapeze support hangers shall be spaced on maximum 60 in. (1500 mm) centers. Hanger rods or straps shall be anchored with steel drop in or wedge expansion type masonry anchors. No additional protection is required for hangers and supports meeting the requirements of the Table below.

Hanger Cross Section	Maximum Perimeter, in (mm)	Trapeze Support (or equivalent Yield Strength), in (mm)
1 in x 16 gage strap (25 mm x 1.5 gage strap)	96 (2438)	
1/4 in (6 mm) threaded rod	56 (1422)	2 (51) x 2 (51) x 18 (3) in angle
3/8 in (10 mm) threaded rod	148 (3759)	2 (51) x 2 (51) x 18 (3) in angle
1/2 in (12.7 mm) threaded rod	232 (5892)	2 (51) x 2 (51) x 14 (6) in angle

2) HVAC ducts: Trapeze support hangers shall be spaced on maximum 60 in. (1500 mm) centers. Hanger rods or straps shall be anchored with steel drop in or wedge expansion type masonry anchors. No additional protection is required for hangers and supports meeting the requirements of the Table below.

Hanger Cross Section	Maximum Perimeter, in (mm)	Trapeze Support (or equivalent Yield Strength), in (mm)
1 in x 16 gage strap (25 mm x 1.5 gage strap)	120 (3048)	
1/4 in (6 mm) threaded rod	72 (1828)	1½ (38) x 1½ (38) x 3/16 (5) angle
3/8 in (10 mm) threaded rod	184 (4673)	1½ (38) x 1½ (38) x 3/16 (5) angle
1/2 in (12.7 mm) threaded rod	292 (7416)	2 (51) x 2 (51) x 1/4 (6) angle
5/8 in (15.7 mm) threaded rod	512 (13000)	3 (76) x 3 (76) x 3/8 (10) angle

8. Maintenance and Repair

No maintenance is required when installed in accordance with Thermal Ceramics installation instructions. If damage is limited to the foil facing, aluminum foil tape can be used to repair the foil facing. If an area of blanket is found to be damaged the following procedure must be incorporated. If the damaged area is larger than 8” (203mm) x 8” (203mm) the entire wrap section must be removed and replaced according to Thermal Ceramics installation instructions. If the damaged area is small (less than 8” (203mm) x 8” (203mm)), the damaged area must be cut away and replaced with a new section 1” (25mm) larger in length and width than the cut out are, such that the new section can be compressed tightly into the cut out area. All cut edges of the new section must be taped and sealed with aluminum foil tape. The new section must be held in place with either pinning or banding per Thermal Ceramics installation instructions.

9. Limitations

Thermal Ceramics FastWrap XL shall be installed in accordance with these installation instructions. The integrity of FastWrap XL systems is limited to the quality of the installation.

*For personal protective equipment recommendations see the MSDS.

Thermal Ceramics is a trademark of Morgan Crucible Company plc. FireMaster and FastWrap are trademarks of Thermal Ceramics Inc. FastWrap products are manufactured by Thermal Ceramics Inc. and are distributed by authorized distributors.

DuctMate is a trademark of Ductmate Industries Inc.

FireMaster® FastWrap® XL Grease and HVAC Duct Enclosure System 1 or 2 Hour Shaft Alternative / Zero Clearance to Combustibles

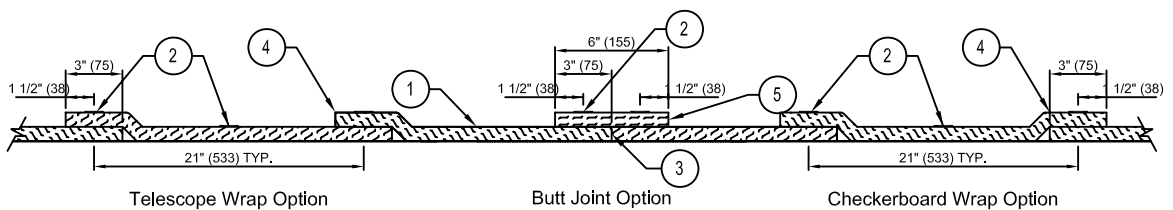
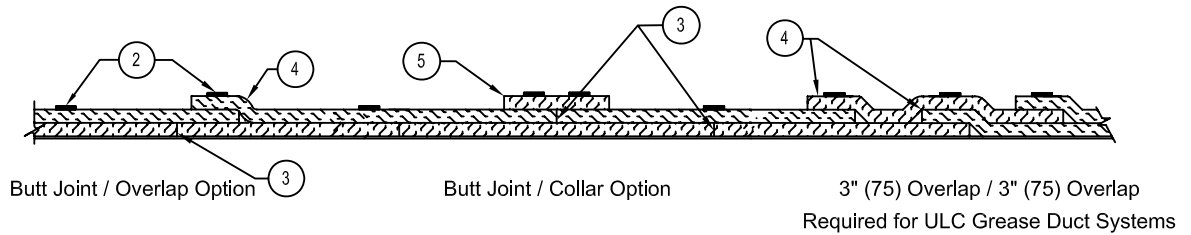
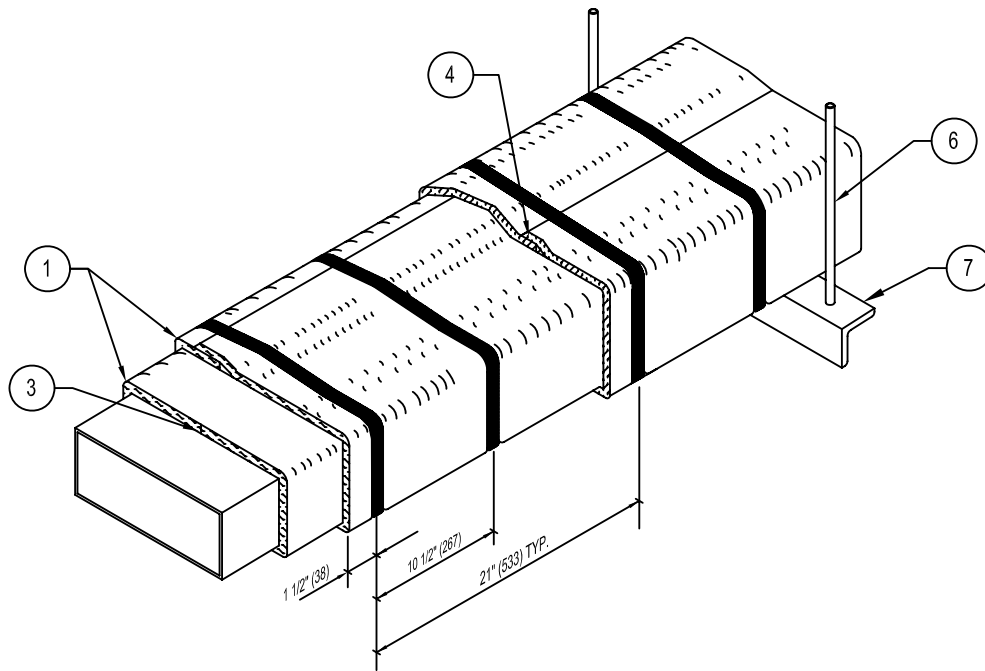

LEGEND	
1	Two Layers of FireMaster FastWrap XL Blanket for Grease Duct Enclosures One Layer of FireMaster FastWrap XL Blanket for Air Ventilation Duct Enclosures
2	Steel banding minimum 1/2" (13) wide by 0.015" (0.4) thick.
3	Tight butt joints on inner layer (ULC Grease Duct requires 3" (75) overlap)
4	Min. 3" (75) overlap on perimeter and between adjacent blanket on outside layer
5	Optional 6" FireMaster FastWrap XL collar
6	Hangers - size dependent weight of assembly (see datasheet Section G)
7	Trapeze Supports - size dependent on weight of assembly (see datasheet Section G)

The integrity of Firemaster duct systems is limited to the quality of the installation.

FireMaster® FastWrap® XL

Commercial Kitchen Grease Duct Enclosure System Air Ventilation Duct Enclosure System Through Penetration Firestop Systems

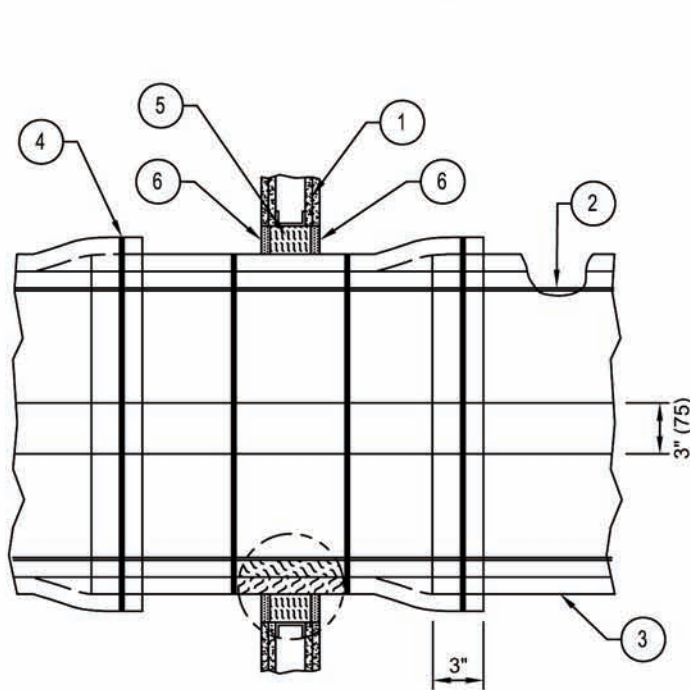

Fastwrap XL continuous through rated wall assembly

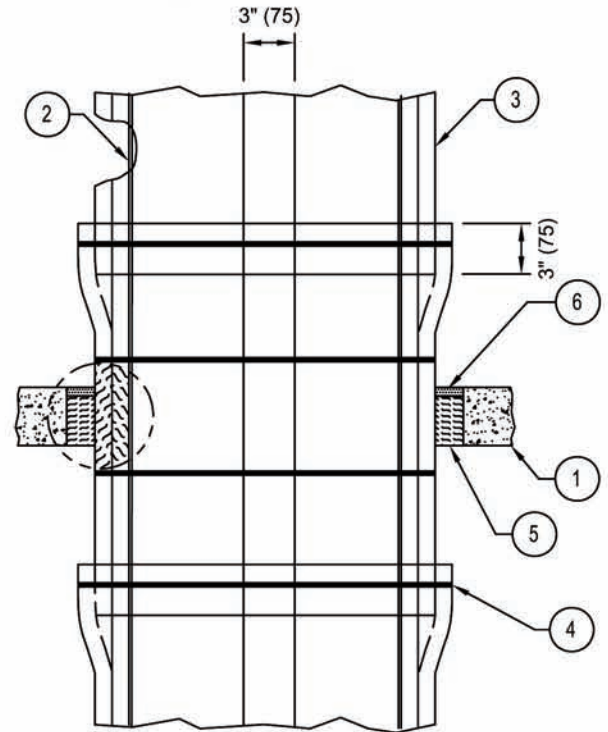

Fastwrap XL continuous through rated floor/ceiling assembly

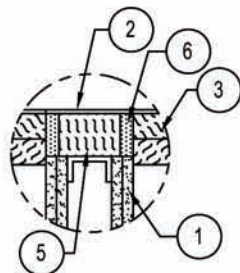

Fastwrap XL terminated on both sides of the rated wall assembly

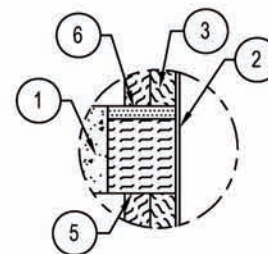

Fastwrap XL terminated at the top and bottom surface of the floor/ceiling assembly

FIGURE 2	
1	Rated Floor/ceiling or wall assembly
2	Duct
3	Two Layers of FireMaster FastWrap XL for Grease Duct Enclosures One Layer of FireMaster FastWrap XL for Air Ventilation Duct Enclosures
4	Steel banding minimum 1/2" (13) wide by 0.015" (1.5) thick or pinning
5	FireMaster FastWrap XL (packing material)
6	Approved through-penetration firestop sealant

Firestop Designs Per ASTM E814 / UL 1479		
UL Listings		ULC Listings
C-AJ-1562	C-AJ-7004	FRD 3
C-AJ-7012	C-AJ-7014	FRD 4
C-AJ-7019	C-AJ-7021	FRD 5
C-AJ-7047	C-AJ-7095	FRD 6
C-AJ-7098	C-AJ-7119	FRD 7
F-A-1093	F-A-1094	FRD 18
F-A-3048	F-C-7036	
F-C-7037	W-L-7009	
W-L-7121	W-L-7145	
W-J-7086		

The integrity of Firemaster duct systems is limited to the quality of the installation.

FireMaster® FastWrap® XL Access Door Systems Commercial Kitchen Grease Duct Enclosure System

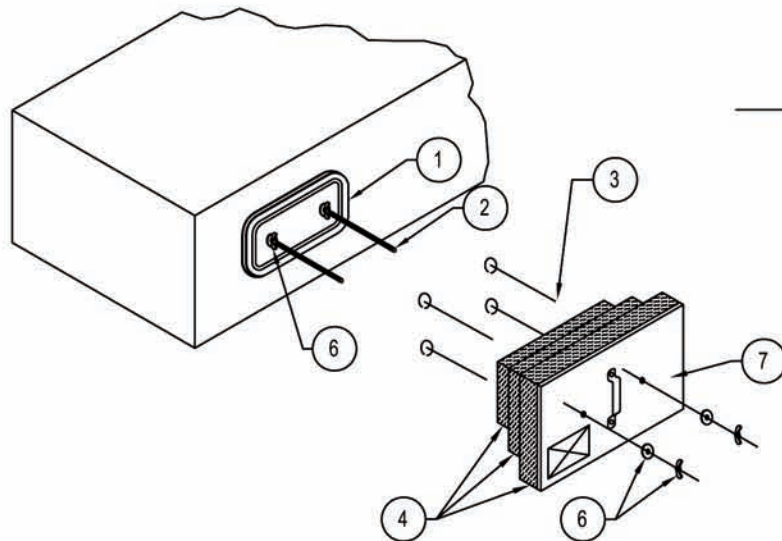

FireMaster F2-HT-XL3 Door System

NOTE: Available from Thermal Ceramics
FireMaster Distributors.

Note:
Label Required
"Access Door"
Do Not Obstruct

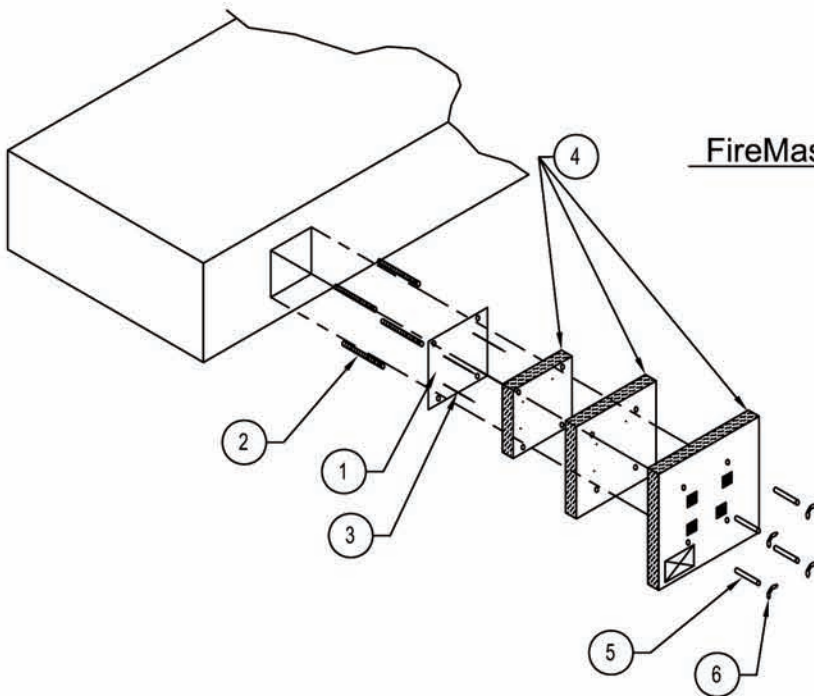

FireMaster Field Fabricated Door System

Note:
Label Required
"Access Door"
Do Not Obstruct

FIGURE 3	
1	DuctMate F2-HT Access Door or 16 Gage (1.5) Field Fabricated Access Door.
2	All Thread Rods.
3	Installation Pins with Speed Clips.
4	Three Layers of FireMaster FastWrap XL Blanket with Minimum 1" (25) Overlaps and All Edges Sealed with Aluminum Tape.
5	Spool Pieces for Threaded Rods
6	Wing Nuts and Washers
7	16 Gage (1.5) Outer Cover Plate Labeled "ACCESS DOOR - DO NOT OBSTRUCT"

The integrity of the duct wrap insulation product is limited to the quality of the installation

FireMaster® FastWrap® XL
 TYPICAL INSULATION PIN LAYOUT
 FOR DUCT SPANS > 24" (610) WIDE
 To Prevent Blanket Sag

SIDE ELEVATION

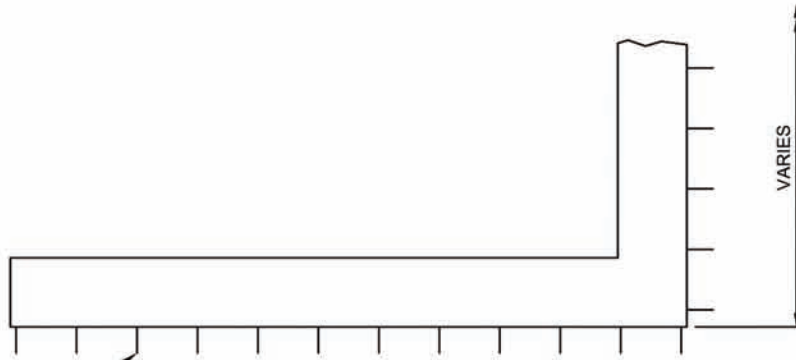

END ELEVATION

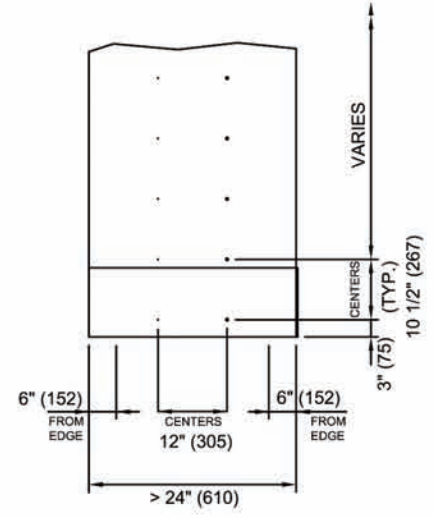

BOTTOM VIEW

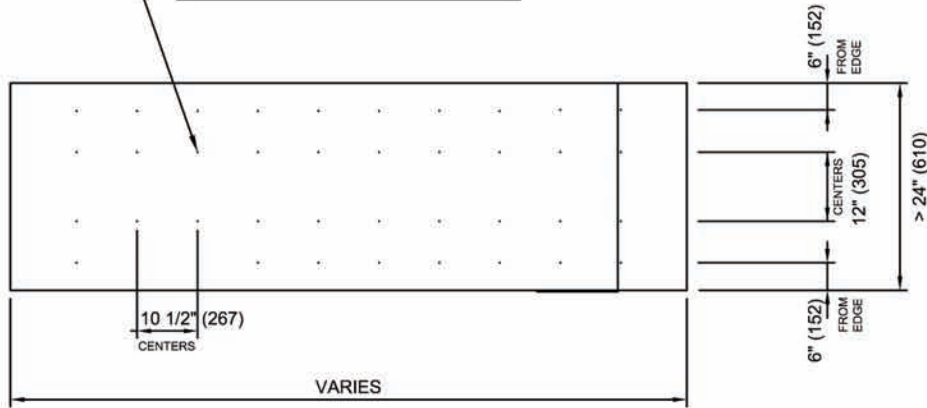

FIGURE 4

1 Minimum 12 gage (3) steel insulation pins

The integrity of Firemaster duct systems is limited to the quality of the installation.

FireMaster® FastWrap® XL Commercial Kitchen Grease Duct Enclosure System Air Ventilation Duct Enclosure System

1 Or 2 Hour Shaft Alternative / Zero Clearance to Combustibles
2 and 3 Sided Wrap Detail for Attaching to Walls and/or Ceilings

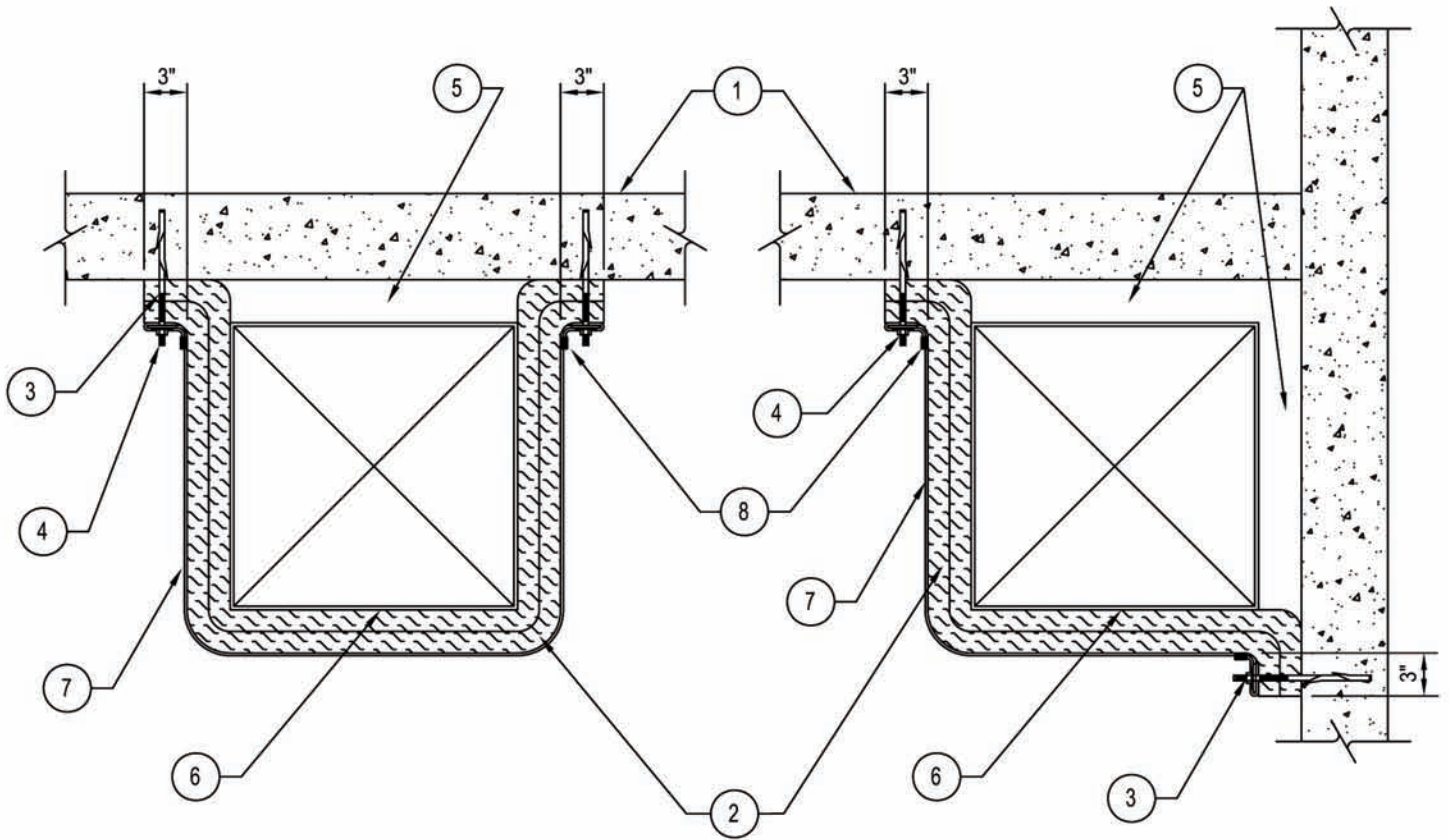

Note: Ducts must be independently supported per code

FIGURE 5	
1	1 or 2 Hour Rated Concrete floor, ceiling, or wall
2	Two layers of FireMaster FastWrap XL for Grease Duct Enclosures One layer of FireMaster FastWrap XL for Air Ventilation Duct Enclosures
3	Concrete fastener system
4	3/16" (5) thick x 2" (50) - 3" (75) wide bar stock perforated 12" (305) o.c.
5	8" (203) maximum Air Gap
6	Duct
7	Steel banding min. 1/2" (13) wide by 0.015" (0.4) thick.
8	Banding clip

The integrity of Firemaster duct systems is limited to the quality of the installation.