

365002

JPRS-UCR-85-014

26 September 1985

DTIC QUALITY INSPECTED

USSR Report

CONSTRUCTION AND RELATED INDUSTRIES

DISTRIBUTION STATEMENT A

Approved for public release;
Distribution Unlimited

19980318 123

FBIS

FOREIGN BROADCAST INFORMATION SERVICE

REPRODUCED BY
NATIONAL TECHNICAL
INFORMATION SERVICE
U.S. DEPARTMENT OF COMMERCE
SPRINGFIELD, VA. 22161

8
81
A05

NOTE

JPRS publications contain information primarily from foreign newspapers, periodicals and books, but also from news agency transmissions and broadcasts. Materials from foreign-language sources are translated; those from English-language sources are transcribed or reprinted, with the original phrasing and other characteristics retained.

Headlines, editorial reports, and material enclosed in brackets [] are supplied by JPRS. Processing indicators such as [Text] or [Excerpt] in the first line of each item, or following the last line of a brief, indicate how the original information was processed. Where no processing indicator is given, the information was summarized or extracted.

Unfamiliar names rendered phonetically or transliterated are enclosed in parentheses. Words or names preceded by a question mark and enclosed in parentheses were not clear in the original but have been supplied as appropriate in context. Other unattributed parenthetical notes within the body of an item originate with the source. Times within items are as given by source.

The contents of this publication in no way represent the policies, views or attitudes of the U.S. Government.

PROCUREMENT OF PUBLICATIONS

JPRS publications may be ordered from the National Technical Information Service (NTIS), Springfield, Virginia 22161. In ordering, it is recommended that the JPRS number, title, date and author, if applicable, of publication be cited.

Current JPRS publications are announced in Government Reports Announcements issued semimonthly by the NTIS, and are listed in the Monthly Catalog of U.S. Government Publications issued by the Superintendent of Documents, U.S. Government Printing Office, Washington, D.C. 20402.

Correspondence pertaining to matters other than procurement may be addressed to Joint Publications Research Service, 1000 North Glebe Road, Arlington, Virginia 22201.

Soviet books and journal articles displaying a copyright notice are reproduced and sold by NTIS with permission of the copyright agency of the Soviet Union. Permission for further reproduction must be obtained from copyright owner.

26 September 1985

USSR REPORT
CONSTRUCTION AND RELATED INDUSTRIES

CONTENTS

CONSTRUCTION PLANNING AND ECONOMICS

- Advances in Computer-Aided Design in Construction
(V.S. Kulikov; STROITEL'STVO I ARKHITEKTURA, No 5,
May 85)..... 1
- Greater Commitment To Complete Unfinished Construction Urged
(SOTSIALISTICHESKAYA INDUSTRIYA, 21 Jun 85)..... 4

HOUSING CONSTRUCTION

- New Rural Housing Construction Policy in Estonia Discussed
(Mai Kalm; SOTSIALISTLIK POLLUMAJANDUS, No 14, Jul 85).... 6
- Quality Up for Urban Housing Construction in Kazakhstan
(E. Ozoling; AGITATOR KAZAKHSTANA, No 11, Jun 85)..... 13
- Suburban Housing Renovation Program in Estonia Viewed
(Ulo Pihlak; SIRP JA VASAR, 15 Mar 85)..... 16

CONSTRUCTION MACHINERY AND EQUIPMENT

- Flexible Manufacturing in Residential Construction
(Robert Vladimirovich Kryukov; GIBKAYA TEKHNILOGIYA
DOMOSTROITEL'NOGO PROIZVODSTVA (NOVOYE V ZHIZNI, NAUKE,
TEKHNIKE: SERIYA "STROITEL'STVO I ARKHITEKTURA"), No 4,
Apr 85)..... 23
- Data on Construction Work, Equipment Utilization
(P.I. Moiseyev; MEKHAUZATSIYA STROITEL'STVA, No 2,
Feb 85)..... 47

Arguments for Replacement of Obsolete Construction Equipment (E.A. Dolginin; MEKHANIZATSIYA STROITEL'STVA, No 4, Apr 85).....	55
Specifications of Dual Wall Construction Method Viewed (I.S. Barshak, et al.; ZHILISHCHNOYE STROITEL'STVO, No 3, Mar 85).....	65
Highlights of Development of Soviet Cement Industry Viewed (TSEMENT, No 5, May 85).....	69
Shortage of Construction Materials Noted in Kirghizia (Ye. Kozlov; EKONOMICHESKAYA GAZETA, No 24, Jun 85).....	76

ADVANCES IN COMPUTER-AIDED DESIGN IN CONSTRUCTION

Kiev STROITEL'STVO I ARKHITEKTURA in Russian No 5, May 85 pp 24-25

Article by V.S. Kulikov, deputy chief of the Main Administration for Planning Organizations of UkSSR Gosstroy: "Systems for Automatic Planning"/

Text Over the past few years, in many branches of the national economy, systems for automatic planning have been created which make it possible to raise considerably the quality of planning solutions, reduce the planning schedules and raise the labor productivity of scientists, researchers and planners. In particular, these systems underwent intensive development and introduction into capital construction following the adoption in March 1981 of the decree of the CPSU Central Committee and the USSR Council of Ministers entitled "Measures for Further Improving Planning-Estimates Work." This important trend in scientific-technical progress in planning is developing within the framework of a five-year union all-round program for the automation of planning work.

Considerable work is being carried out in our republic in connection with the creation of systems for automatic planning. In accordance with the all-round republic program, which is a component part of the union program, the plans call for the level of automated planning operations to be raised to not less than 17 percent of the overall volume of such work in 1985, including for the planning organizations of UkSSR Gosstroy -- more than 20 percent. Within the republic, the program tasks are for the most part being carried out and some planning organizations have already reached the 1985 level. The positive results achieved in recent years in automatic planning were presented during a special inter-branch exhibit entitled "Leading Experience in the Use of Automatic Planning Systems," in the Construction Pavilion of the UkSSR VDNKh Exhibition of Achievements of the National Economy of the USSR/. The exhibit was organized by UkSSR Gosstroy, UkSSR Academy of Sciences, UkSSR VDNKh and the republic's Gosplan. More than 50 planning, research and scientific-research organizations of 16 ministries and departments throughout the republic and the country presented works having to do with the use of SAPR's sistema avtomatizirovannogo proyektirovaniya; system for automatic planning/ in construction, machine building, radio electronics, metallurgy and other branches of the national economy.

During 4 years of the 11th Five-Year Plan, success was achieved in the area of construction in raising the level of automatic planning operations by a factor

of 3-4, supplying the planners with modern computer equipment and, on this basis, carrying out the planning for a number of unique and large projects. Some of them were presented on stands during the exhibit. This included a residential block in Moscow Rayon -- a unique complex of multiple-story dwellings, a building for a laboratory complex of the Kiev Branch of the Scientific Research Institute for Communications on Solomenskaya Street, blast furnace No. 9 of Krivorozhstal', the largest in Europe, the Kiev Branch of the Museum V.I. Lenin, a complex for the Museum on the History of the Great Patriotic War, the Moscow Bridge across the Dnepr River in Kiev and modernization of the Golden Gates -- a valued memorial of the past. It was possible to carry out the planning for these installations on a high technical level as a result of multiple variant computations on an EVM [electronic computer] and the use of mathematical models for complicated spatial structures.

New technical items of equipment, created at the level of the best models, are being demonstrated throughout the country in the form of operating exhibits: a program-technical complex for an automated working position for a planner-builder (ARM-S) at the Kiev Production Association Elektronmash imeni V.I. Lenin, a subscriber point for the work of users located at great distances from the powerful EVM's of NIASS of UkSSR Gosstroy, and a Rech'-1 technical unit for vocal dialogue of the Cybernetics Institute imeni V.M. Glushkov of the UkSSR Academy of Sciences. Here it is possible to see how computations for complicated construction designs are carried out within a matter of minutes in a dialogue regime for the work of a planner with an EVM. Using graphic and alphabet-digital displays, optimum planning solutions are selected which are immediately traced out on automatic graph units (graph builders) and estimates and reports on the requirements for construction materials are prepared.

The creation of systems for automatic planning requires first of all the development of methodological support for them, with the principal developers in the republic being the Cybernetics Institute, NIASS, Ukrproyektstal'-konstruktsiya, the Kiev Engineering-Construction Institute and others.

An important aspect in the creation of SAPR's is the organization of operational contacts, an exchange of information between the planners and an EVM. From this standpoint there is definite interest in the subsystems employed for the processing of graphic information in an EVM, for a graph-builder of cartograms (Cybernetics Institute), a dialogue graphic subsystem for processing and issuing the results of stable computations in the form of projection diagrams and isolines for deformations and internal stresses (KISI) and an interactive subsystem for the compositional placement of a promising image for architectural projects on the INTEAR graphic display (NIASS, KISI).

The solution for the task of complete automation is associated with one very important technical component of a SAPR -- program-technical complex for an ARM [avtomatizirovannoye rabocheye mesta; automated working position]. Such complexes are produced by domestic industry. In particular, Elektronmash produces five ARM modifications, oriented towards various branches of the national economy.

Considerable interest is being displayed in complete SAPR systems and subsystems: departmental SAPR-OS of UkSSR Gosstroy, SAPR's for Giprograzhdanpromstroy,

Ukrgipromeza, Giprokhimmash and others, technological lines for planning and packages of applied programs.

The detailed technology for automated planning is illustrated using Giprograzhdanpromstroy and its branches as an example, all of which have adequately developed SAPR's for central production and where the level of automation today exceeds 20 percent. In the institute's SAPR structure, use is made of a number of modern programming means for automating the planning for belt and columnar foundations, reinforced concrete structures, items of sanitary-technical equipment, technological lines for ceiling planning, skeleton-panel buildings and subsystems for the automatic production of estimate documentation and reports on material requirements for construction products and structures. It is here that the examples of finished planning output are shown -- drawings, estimates and specifications.

Deserving of special attention is the SAPR for Khar'kovproyekt for coordinating installations of civil housing construction, which is carried out at three principal levels: general plan, microregion and installation. Towards this end, use is made of technological lines for planning the external networks for the engineering equipment. The issuing of graphic information is carried out using the program complex. From a subject standpoint, the SAPR's for Giprograzhdanpromstroy and Khar'kovproyekt are associated with the SAPR's for Ukrniipgrazhdansel'stroy and Gipograd.

The exhibition also included achievements associated with the development of civil construction projects using SAPR means of KievZNIIEP and Glavkiyevproyekt and SAPR's were also shown for projects of chemical machine building, steel structures and enterprises of light industry.

One section of the exhibit was dedicated to the automation of office research work, during the course of which information is prepared on engineering-geological conditions and topographical-geodetic surveys are carried out on the construction sectors. It is noted that the research work is on the whole sufficiently extensive and that it constitutes 20-30 percent of the entire volume of planning-research work. This section reflects the overall status of work concerned with the automation of research studies, it provides a description of the package of applied programs for the automation of office work and it contains an operating experimental model of a technical unit for the automatic recording and reproduction of field test data (development of UkrGIINTIZ and NIASS).

An important trend in the complex of operations associated with SAPR's is reflected in the UkSSR Minvuz Ministry of Higher Educational Institutes exhibition, where SAPR personnel are trained (or retrained) in special SAPR branches at KPI Kiev Polytechnic Institute and at KISI Kiev Engineering-Construction Institute, at courses for improving skills and at short-term problem-oriented courses in the SAPR Branch of NIASS.

The exhibit developed a great amount of interest among the planners, research workers and scientific workers. The extensive use of leading experience in practical work and the use of systems for automatic planning are promoting improvements in the scientific-technical level for planning and construction.

COPYRIGHT: Izdatel'stvo "Budivel'nik", "Stroitel'stvo i arkhitektura", 1985.

CONSTRUCTION PLANNING AND ECONOMICS

GREATER COMMITMENT TO COMPLETE UNFINISHED CONSTRUCTION URGED

Moscow SOTSIALISTICHESKAYA INDUSTRIYA in Russian 21 Jun 85 p 1

[Article: "Capacities--Ahead of Schedule!"]

[Text] On the initiative of labor collectives of construction and installation organizations and industrial enterprises in developing socialist competition for the pre-schedule operational introduction of production capacities and facilities of primary state importance in 1985.

In the resolution which it adopted on this question, the CPSU Central Committee approved the initiative of the labor collectives of construction and installation organizations and industrial enterprises in the cities of Moscow and Leningrad, in the Ukrainian SSR, the Georgian SSR, the Azerbaijan SSR, the Lithuanian SSR, Altayskiy and Primorskiy Krays, the Bashkir and Mari ASSR, the Belgorod, Bologda, Penza, Saratov, Chelyabinsk and a number of other republics and oblasts which took on additional responsibilities for the pre-schedule operational introduction of 54 production capacities and facilities of primary state importance in 1985 in honor of the 27th CPSU Congress.

The union republic communist party central committees and CPSU kraykoms and obkoms received a recommendation to direct their organizational and mass-political work toward the widespread promulgation of this initiative and to mobilize the efforts of the labor collectives at construction sites and enterprises toward ensuring the operational introduction of all start-up capacities in the current year. Particular attention was given to the construction of enterprises associated with the introduction of progressive technology, new types of construction materials and high productivity engineering into production practice, facilitating the acceleration of scientific-technical progress. Unflinching party control must be implemented over the fulfillment of plans for construction of housing, facilities of social-domestic function, the agro-industrial complex, and enterprises for the manufacture of consumer goods. Construction work associated with preparation for winter must be completed in time.

The USSR Ministry of Construction of Heavy Industry Enterprises, USSR Ministry of Industrial Construction, USSR Ministry of Construction, Ministry of Construction in the Far East and Transbaykal Regions, Ministry of Transport

Construction, USSR Ministry of Rural Construction, USSR Ministry of Installation and Special Construction Work, Glavmosstroy [Construction in Moscow Main Administration] under the Mosgorispolkom, Glavmospromstroy [Industrial Construction in Moscow Main Administration] under the Mosgorispolkom, Glavmosoblstroy [Construction in Moscow Oblast Main Administration] under the Mosoblispolkom, and customer ministries, working in conjunction with the AUCCTU, will establish permanent effective control over the course of socialist competition. They will systematically summarize its results, will make widespread use of measures of moral and material incentives for achieving high results in the competition for pre-schedule operational introduction of production capacities and facilities of first-rate state importance, and will render the competing collectives the aid necessary for unconditional fulfillment of the increased responsibilities which they have accepted.

The USSR Gossnab [State Committee for Material and Technical Supply] and the customer ministries are organizing the comprehensive and timely delivery of technological equipment to start-up construction sites, as well as the continued provision of construction organizations with material-technical resources.

It was recommended that the central and local newspapers, television and radio regularly illuminate the initiative of the labor collectives of construction-installation organizations and industrial enterprises in the pre-schedule operational introduction of production capacities and facilities of first-rate state importance in 1985, and that they widely propagandize the experience of leaders in production.

12322

CSO: 1821/138

HOUSING CONSTRUCTION

NEW RURAL HOUSING CONSTRUCTION POLICY IN ESTONIA DISCUSSED

Tallinn SOTSIALISTLIK POLLUMAJANDUS in Estonian No 14, Jul 85 pp 22-24

[Article by Mai Kalm: "Size of Family Dwelling Under Discussion"]

[Text] The thoughts stem from a republican conference on planning and constructing family dwellings held in the Rakvere rayon in April of this year. Reports were heard from our republic's construction leaders, planners and economists, and several independent economic units in the rayon were visited.

Our Housing Construction Against All-Union Background

Up until 1984, construction had taken place on 10.9 million square meters of living space in the Estonian SSR countryside. This comes to 21 square meters per rural inhabitant in our country, at the same time as this indicator is 8 square meters in the Uzbek SSR, for example. It is sufficient from this very fact to draw conclusions about the all-Union distribution of resources. Yet dry statistical figures are deceptive; nor do they properly reflect the actual circumstances. We are still haunted by 12,000 empty country houses. In the countryside there are a lot of only partially inhabited summer homes of city folk, and quite a few countryside people live in houses which urgently await extensive repairs or complete demolition. Rural inhabitants are not distributed uniformly on our small territory. Thus there are less than 9 workers per 100 hectares of arable land in the Rapla and Paide rayon, altogether 7 workers in the Haapsalu rayon, but 12.7 workers in the Harju rayon. This also partly explains why there are so many empty houses.

At the same time, our republic is in last place in the entire Soviet Union in the construction of one-family dwellings. In our country in 1984, one-third the all-Union average of family dwellings were built per number of farm workers. The situation is best in the Lithuanian SSR where there has been construction--with state credit--worth as much as 58 million rubles a year. By the same method, there was construction worth 3 million rubles in our republic in 1984. We built altogether 638 one-family houses last year, and we will build roughly 800 houses in 1985.

The Lithuanian Kolkhoz Building Association constructs family dwellings well in Lithuania. This year all the builders there plan to construct 4,500 family

houses together with outbuildings. Our EKE [expansion unknown] organizations built 83 individual dwellings in the year 1983, 101 in the year 1984, and this year it is hoped they will build 150. There was a commitment, however, to construct 300 family houses a year.

It is forbidden to construct dwellings higher than two stories and with more than eight apartments in the rural districts of the Lithuanian SSR.

These are the ideas from the speech of Jaan Ots, deputy chairman of the Estonian SSR Agroindustrial Association.

After thinking the matter over, one is left with the impression that we have acted quite properly. If we have so much surface per rural worker and yet we have built a lot of city-type panel houses in the countryside, then the brakes must be applied completely to the construction of family dwellings in order to approach the statistical all-Union average. What would have happened if we had been building for years equally well as the Lithuanians? It follows from this once more that a decision on the actual situation cannot be made solely on the basis of the statistical average.

What Has Construction Been Like on the Independent Economic Units of the Rakvere Rayon?

The center of the Viru kolkhoz is in Haljala. There section dwellings and-- in between them--small individual dwellings surround the large administration buildings. Since altogether 1,200 persons live in Haljala, roughly 34 percent of them dwell in one-family houses. With their well-kept gardens and comparatively diverse assortment of designs, the small-dwelling districts look really nice.

Construction has taken place in many different ways. When housing cooperatives came into vogue, several of them were built here. Many builders have recently availed themselves of the opportunity to take out loans. Many individual projects have also been realized with private capital. Right now the construction of small houses is expanding on every front. All of them are located in planned sites and can take advantage of the widening services of the settlement's external networks. Opportunities for keeping domestic animals, however, have not been created to any noteworthy degree in the Haljala settlement. They have been provided for in houses located outside the central settlement. It seems that the stronger the independent economic unit, the stricter the work discipline, and the greater the pay, the less interest in--and opportunity and need for--keeping domestic animals.

Driving from Haljala through the outskirts of Rakvere to the model sovkhos technical training school in the central settlement of Vinni, one does not see any special difference between the city of Rakvere and the settlement of Haljala. Thus the center of a prosperous independent economic unit is rather citylike, more like a small city itself.

Years ago the little market town of Vinni was awarded a prize in all-Union competition for effectual planning and good organization. Vinni was then

singled out as a settlement in which there was a shortage of family dwellings. But nothing about the general change of direction remains unaffected. Several districts with small dwellings have now been planned for the Vinni central settlement. Construction of the model projects "Ella" and "Ants" was launched with great eagerness in 1981, and today six houses are ready. A district of small dwellings with opportunities for keeping domestic animals is also planned for the other side of the central settlement.

A great many individual dwellings, as much as 30 or 40 years old, stand in Pajusti in the center of the E. Vilde kolkhoz. Row houses and newer individual dwellings have also been built there. But the eyes do not take delight in the large dwellings strung between them.

A village new in its own way has been established a few kilometers from Pajusti near the Kakumae farm in the direction of Viru-Jaagupi. A truly pleasant site has been found for the new village: a glade close to a fairly big road. The 18 houses have been built around the fringe of the forest glade; access roads and lines of communication have been established. Dwellings with the possibility for keeping domestic animals have been constructed here in accordance with model project B-2-1/73; there is a sauna and opportunity for keeping domestic animals in the houses built in compliance with the "Villi" project. But the one-family dwellings constructed in accordance with the individual project of architects Tiit Hansen and Voldemar Herkel constitute something worth seeing. These four houses are located around a natural hill; a one-story bipartite building has been constructed on a different level. In addition to storage space, there is a sauna in the cellar. Attached to the house is a garage, and a greenhouse connects different surfaces. The houses are attractive and rather luxurious. They aroused a lot of excitement among the conference participants. "I want my wife to be a free person at the end of the workday, not a charwoman moonlighting at home," thought one young man. In all likelihood, these houses are not suitable for mass construction. Such a house costs 42,000 rubles at the old prices.

According to kolkhoz architect T. Hansen, it is possible for everyone in the Kakumae village to keep animals, but few do. Maybe the reasons are the same as we discussed before.

Construction Policy's Ebb and Flow

In order to understand today's trends in construction, we must in spite of ourselves ponder their ebb and flow. It is interesting to put oneself in the place of an ordinary farmworker during one era or another who at any moment wishes to safeguard his family's life and bind himself to the soil. Actually there have been individual builders in our country during every era. The desire to own one's own house was considered a "sin" in postwar periods, but there nevertheless emerged during these times quite a few small gable-roofed houses, which are at present lost among the gardens. They now give an excellent look to those central settlements which have withstood the tests of time and remained in place. Subsequent builders regarded the high gable roof as old-fashioned, the boundary standards as too small, and thus dwellings of the small-town or village type with low roofs began to spring up here and there. Homeowners were no longer

looked at askance, but the builder's life was still not easy. It was necessary to obtain materials, find those workers who could do the special jobs adequately, and spend all of one's own free time on construction. At that time, it was thought that one-third of the house's price should go into materials, one-third into transportation, and one-third into labor.

Then housing cooperatives began to be established, the building organization took over the construction worries, and one could take up residence in a finished house. It cost more, to be sure, but many were very satisfied with it. The planning standards promise to construct even roomier houses.

At the same time, there were persons who desired to live separately away from the settlement. This was still not permitted, however. Construction policy provided for the concentration of inhabitants in settlements. In the Lithuanian and Latvian SSRs, people were transplanted to the settlements in part by force. It did not go that far here, but construction of a new dwelling on the site of an old house was not allowed.

Five years ago, however, a cardinal change occurred in construction policy. Individual construction was encouraged from all quarters. Considerable credit advantages for construction pushed the cooperatives into the background. Planning quotas were increased, permission was given to build away from the settlement, and the keeping of domestic animals by individuals was recommended. He who now quickly seized the opportunity could build to his advantage and according to his wishes. New difficulties cropped up, of course: the projects were not suitable for the countryside, they were mostly houses of the city type. Then the high gable roof was rediscovered. There appeared projects in the "Ants" series in which the houses became more and more spacious. Even so, these were not functionally proper country houses. The price of houses rose 21 percent in connection with the increased cost of building materials, 16 percent due to an increase in surface standards.

We have reached the point today where construction cost proves to be crucial. It is no longer expedient to build all at once a finished house with many rooms, a garage, a sauna, a cellar and other amenities. Construction of such a dwelling is not financially suitable for many, particularly young builders. Current construction policy admonishes us to be moderate. That way we can build more and leave the possibility for making additions to the homeowner himself. But the desire to build endures and grows. The person who is interested must immediately seize the proper opportunity, because life shows that he who builds today wins tomorrow.

How Could It Be Built More Cheaply?

This is the number one question in the construction policy of the present period. To begin with, the current projects for small dwellings were examined. Only 4 out of nearly 40 projects turned out to be appropriate, 16 projects were revised to reduce construction costs, and many projects were erased from the list. Now considered acceptable are the "House" series worked out in the "Estonian Land Construction Project," as well as the "EKE Project" and the "Mini-Sprit." It is recommended that these dwellings be built chiefly in the

vicinity of farms situated some distance from the center or in smaller auxiliary settlements.

In addition to costliness, many projects were charged with being functionally unsuitable for the countryperson, for the small-scale agricultural worker. The ill-advised projects were bloated with balconies, terraces, halls and other such things. At the same time, they lacked a division of the edifice into a clean and a dirtier half, possibilities for placing and drying work clothes, a farm kitchen, etc.

The possibility for the gradual completion of a building as a mansard or an annex is considered a basic requirement of today's project. This way the dwelling can be obtained relatively cheaply and, as the family and opportunities grow, one finally finishes building the house.

It is possible to build dwellings with stove heating and lavatory everywhere on the farm's territory. Furthermore, there remain still other possibilities such as combined electrical and stove heating, local cleansing installations, etc. All of them can be introduced gradually. The "Air" housing project, which conforms to both planning and credit-granting standards, was elaborated in the "EKE Project." The house's cellar is provided with a big furnace, and hot air heats the three- or four-room dwelling through pipes.

Employment of the prospective owner's work force also renders the construction of small dwellings on credit cheaper for the independent economic unit. It is conceivable that the person himself lays the foundation base, adds the finishing touches inside, etc. At the "Spark" sovkhos in the Parnu rayon, the house builder is freed from basic work during the time of construction and undertakes the job of building his own house. It guarantees quality control at the same time. The extent of good organizational work, which is included in construction costs, must be within reasonable bounds. The house owner should be given a free hand here to apply his own taste.

Geological research work does not need to be done separately for each dwelling, only jointly for the corresponding district or group of dwellings.

As far as possible, local materials should be used in constructing the house. Brick sidings on a dwelling of blocks are obvious overplanning. (But is local wood cheap or are the construction materials produced in the EKE system cheap?)

The case of a cellar under the house is complicated. The standards do not allow provision of a full cellar. Yet a cellar under the house should not be more expensive than the construction of storage rooms as an aboveground annex. A countryperson, however, requires plenty of storage space to hold his yearly supplies of fruits and vegetables, potatoes, canned goods, fuel, etc. There remains the later construction of a cellar with earthen walls in the farmyard, where very good conditions for cold storage can be created. At the same time, such a cellar can be skillfully used as a burnishing element.

Up until now, a sauna has been viewed as a luxury for the construction of which state credit is not granted. During the last century, to be sure, not a single

countryman would believe that his smoke sauna on the farm was a luxury. A bathroom is not considered a luxury, however. Hence emerged the possibility of constructing a country house without a bathroom and only with a sauna, which together with a shower and a cauldron for washing clothes would be far more multifunctional and would find greater application.

It is the same story with a garage. If in the name of keeping down costs we have to omit a garage and keep a frequently more expensive car in the yard, then the opportunity to build a garage must be provided, if one so desires. The time is past when a car was regarded as a luxury. It is not proper from the state's standpoint if, for example, an authority's official car stands before the house in a snowdrift in the winter, not to mention a private car into the acquisition of which a lot of sweat and hardship has likewise gone.

This year the Parnu Housing Construction Combine's department of wood shaving slabs begins work: 40,000 cubic meters of slabs will be obtained annually for the walls, floors and ceilings of dwellings. In 5 years the combine must turn out the wooden components for 600 family dwellings of silicalcite blocks and 600 dwellings mounted from wooden panels. According to current calculations, one such house will cost approximately 30,000 rubles. The price of an industrial family dwelling depends on the conceded conception, to which corresponds the room outline and the constructional solution. Industrially produced components can also be used in the construction of row houses, where a one-family lodging can be acquired for roughly 20,000 rubles.

The "Estonian Land Construction Project" offers a four-apartment dwelling together with rooms for keeping small animals, where the cost of one four-room apartment is about 14,000 rubles.

All family dwellings in the Lithuanian SSR are built with outbuildings. For the outbuilding, a model project has been worked out which is linked to each dwelling. In recent years in our country, several projects for outbuildings have been worked out, which have all proven to be too expensive. The construction of outbuildings with a dwelling increases the cost of the dwelling considerably. Estonian farm tradition permits the construction of outbuildings separately or altogether under one roof. There is therefore no reason to fear deviating from tradition in one case or the other. It is a matter of money whether to construct the outbuilding complete with the dwelling or to build it little by little. In any event, the traditional country home requires free access, above all, to the yard and from there into the house, not a main entrance from the street.

In Summary

The farmstead-type house must be inexpensive, economical, sensible and correspond functionally to the demands of rural life and agricultural production. From the architectural standpoint, it must harmonize with the settlement and the surrounding nature. The mistake lies in the fact that existent projects are now criticized and yet by no means have houses been built in accordance with all of them. There is still no concrete house as a basis for evaluation. It would be good to build-- in an accelerated way--experimental houses on farms according to various new plans and then in accordance with them develop the model projects.

Conferences in which the character of the country house is discussed by those who actually use them as well as by economists and designers have an essential importance. The public must be informed about construction policy in order to draw its own conclusions. The situation has currently arisen in which people want to build bigger and bigger houses. But bigger is also costlier and by no means always the most expedient. The establishment of cost limits is thus critical in our republic.

There has to be a clear difference between the houses which residents build with their own capital and those which are constructed thanks to the independent economic unit with a state loan. If the house builder's pocketbook allows it and if there is strength to bear it, he can wring the maximum out of the standards and resort to a unique project. However, let houses built with state loans be simpler and optimal with respect to spaciousness and cost. To incline toward oversimplification is not right, either, because the house is built by a human being alive once, after all. Recommended the most right now are gradual completion of construction and seizure of the advantages of building courageously with credit. Toomas Varik, chairman of the Viru kolkhoz, said at the conclusion of his speech: "Today's expensive house is cheap tomorrow." And this can be believed, because there has been brisk construction at the Viru kolkhoz both yesterday and today, and it will also certainly be so tomorrow.

COPYRIGHT: "Sotsialistlik Põllumajandus" 1985
Kirjastus "Perioodika"

12327
CSO: 1815/68

HOUSING CONSTRUCTION

QUALITY UP FOR URBAN HOUSING CONSTRUCTION IN KAZAKHSTAN

Alma-Ata AGITATOR KAZAKHSTANA in Russian No 11, Jun 85 pp 28-29

[Article by E. Ozoling, head of the Residential-Civil Construction Administration of the Kazakh SSR Gosstroy: "The Quality of Our Home"]

[Excerpt] Tell us about the measures taken in the republic to raise the quality of residential construction and about how the architectural image of our cities and towns is improving.--The Zhakupov family, Semipalatinsk.

E. Ozoling, head of the Residential-Civil Construction Administration of the Kazakh SSR Gosstroy, answers the readers' question.

Every year nearly 6 million square meters of living space are created in the republic. Since the beginning of the five-year plan 620,000 families have received new apartments. This means that roughly every 80 days it is as if a new city of 100,000 inhabitants appears in the republic.

Now we widely use standard residential designs of the third generation in construction. The residents of the republic receive apartments with comfortable, spacious entrance and kitchens, high-quality summer rooms of the lodgia or balcony-lodgia type, and isolated general purpose and sleeping rooms. The level of heat-insulation and sound proofing in houses has risen, and the volume of construction of three- and four-room apartments has increased.

The block section method of drafting, by which each entrance in the home is given its own character, has entered strongly into Kazakhstan's urban construction practices. Thus great possibilities for a harmonic and highly artistic solution for mass construction and the satisfaction of workers' aesthetic demands are open to the architects. The introduction of block-sections of various configurations and with varying numbers of stories has allowed some diversification of the architecture of house facades and their plastic decoration.

Our cities have been touched by the fresh wind of a new approach toward the solution of problems of residential construction. Thus, the creative cooperation of architects and home builders of Karaganda has given birth to a new block-component method of structure, which creates individual characteristics for the apartments on each floor. Only the first steps have been taken. The Orbit micro-region and the experimental Stepnoy micro-region have been announced. Colored designs for the facades of glazed tiles and silicon-organic paint are being used here; originally built summer accommodations and heat roovers are being introduced. In the future the search for the architectural possibilities of this system will be continued...

A new architectural planning and technical system, Mobil, is being introduced in the cities of remote and sparsely populated regions. If each house in a general series is composed of 300 to 400 products, then the new system allows the reduction of their number by three to four folds, and this will significantly speed up residential construction. Buildings in this series are under control of smaller enterprises. The inhabitants of Zhanatas, Zayrem, Gur'yev, Balkhash, and Ust-Kamenogorsk will become convinced of the advantages of the new, spacious and comfortable apartments in the very near future.

At the plenum of the Union of Architects of Kazakhstan, which took place in Pavlodar in May 1984, it was observed that side by side with the definite successes in building our cities, unfortunately, facelessness, greyness and inexpressiveness still exist. Apart from the fact that regulations exist on the urban construction complex, which defines a first order minimum of daily services to be established, the construction of stores, day-care centers, schools, health and cultural centers continues to be dragged out.

Other problems also exist: wallpaper that is too dark or faded, the full absence of or only gloomy-toned glazed tiles in the hallways and living rooms, poor hardware for windows and doors. All of this forces people to commence repairs immediately after moving in. It wastes large material and labor resources. A critical, candid discussion about this took place in the letter "A word on Working Honestly" which leading team leaders submitted to Pravda.

Significant changes are occurring in rural residential construction. The most acceptable and comfortable type of residential rural house is the one-apartment, farmstead-type, with an outdoor structure for keeping livestock and poultry. The area of the structures varies from 15 to 35 square meters, depending on the natural and climatic conditions and the forms of farming.

The total area of the residential house has increased significantly. Thus, for a family of five to six people, a house with a general-purpose room of 20 to 22 square meters, bedroom for

two people, 12-14 square meters, a kitchen 10-12 square meters, and also with auxiliary accommodations where feed can be prepared for the livestock, is envisioned. Pantries and cellars are being built for wintertime storage of foods.

Several standard drafts exist for rural residential houses, but the brick and adobe still are not there. This is why the most important problem of developing the industrial-house building base lies here. For this a few multiple-goal programs have been created in the republic. A number of ministries and departments are building plants for production of heavy and light walled blocks. The leading technology of monolithic house building is being introduced, allowing introduction of the house on an industrial basis. The network of rural construction combines, on which the preparation of large-panel designs will be mastered, is widening.

We have created a powerful, far-flung base for industrial house building. It numbers thirty large enterprises. They have great things resting on their shoulders. The builders see their main task in the creation of unique structures for new regions, raising the quality of residential construction and guaranteeing a maximum of comfort to new settlers.

COPYRIGHT: "Agitator Kazakhstana", No 11, 1985

12926
CSO: 1821/146

HOUSING CONSTRUCTION

SUBURBAN HOUSING RENOVATION PROGRAM IN ESTONIA VIEWED

Tallinn SIRP JA VASAR in Estonian 15 Mar 85 pp 9,13

[Article by Ulo Pihlak, director of the science branch of the RPI Estonian Project: "Some Dwelling Construction Problems and the House of the Suburbs"]

[Text] Improving the people's living conditions is one of our republic's more important tasks. Housing conditions are significant in this respect. Every effort is being made to provide all families with their own well-organized dwellings by the turn of the century.

At the same time, it is no secret that both housing construction and exploitation of the housing stock require considerable state support. This aid has been badly used by a lot of urbanites. One finds that a house (apartment) can be messed up and torn apart with impunity, that the rent can go unpaid, etc. A brief remark here: the author's displeasure is directed primarily at the irresponsible tenants of modern dwellings equipped with all the conveniences.

Two problems ensue from the foregoing. The time has evidently come to regulate rents. The current rental standard in the Estonian SSR was established in 1940. The rent for dwellings in excellent condition should be raised differentially. The present rent does not stimulate dwellers to choose an apartment of sensible size. That is why there are very great discrepancies behind the index of average furnishings (on 1 January 1984, there were 17 square meters of useful space per dweller in the cities of the Estonian SSR). The impartial regulation of apartment rent is, of course, a knotty problem. On the other hand, the rent for communal flats and dwellings in poor condition should be lowered.

Cooperative Construction

The second problem is linked to the greater use of dwellers' savings for housing construction. In the Estonian SSR, 363,000 square meters of cooperative housing were built during the tenth 5-year plan. It approaches 430,000 square meters during the eleventh 5-year plan and must increase continuously. Under the present conditions, however, it is difficult to guarantee this growth. On 1 January 1961, there was an average of 11.4 square meters of total space per urbanite, at the beginning of last year as much as 17 square meters, as mentioned above. This process is continuous. Together with a rise in average furnishings, the number of cooperative builders will certainly decline in the future.

Evidently, in order to raise the competitiveness of cooperative dwellings, the latter must be established in reconstructed living districts in accordance with new model projects. In this way, the favorable location would develop into the cooperative dwelling's new power of attraction. Garages built on a base floor should evolve into a second source of popularity. There is nothing technically insurmountable here. In Hungary, garages bought from us are set into panel dwellings which are built in lodging complexes. Even health and fire-protection regulations do not present insurmountable obstacles. In the final analysis, the first floor of a cooperative apartment house can be populated with garage owners because, according to the statement of M. Pord, only the fumes from another person's car are offensive.

In the draft outline of a so-called suburban house made by architect K. Voolaiu in the 1984 RPI Estonian Project, the garages are planned at the tips in some sections. In this way, however, relatively few garages fit into the base floor, and there are not enough for each family. Accordingly, the cooperatives must be made complete. It is possible, of course, to increase considerably the number of garage spots, placing them in rows against the long side of the apartment building. In that case, a second row of garages could also be built beyond the apartment building. In addition to legal difficulties, an avalanche of protests by builders can be foreseen here. Thus one could go and look at the garage located at 108 Valdeku Street in Tallinn: one row of stalls is situated below the apartment building, the other outside. The turf which covers the roof of the latter and the exit extends to the line of the base. Ventilation is solved together with the apartment house's own. Evidently, the competent institutions should make an effort to see to it that the establishment of this type of cooperative apartment house with garage is realized during the next 5-year plan.

Thirdly, preference for the cooperative builder should be increased substantially in the future. Especially advantageous conditions should be created for young couples by appreciably reducing the down payment, for example. Likewise, one should provide for cancellation of the remaining payments on the cooperative out of resources from the institution/enterprise of advanced worker and cooperative owner, etc.

Private Houses

Greater use of the inhabitants' savings in solving the housing problem can also take place by expanding the construction of private dwellings. There are no special possibilities for this, in my opinion. A land shortage has arisen in the majority of our cities. The seizure of good farmland beneath buildings has rightfully been made difficult. The shortage of land for construction haunts not only the big cities but Voru and Kingissepp as well. For example, Voru is able to put up apartment houses three to five stories high for the collectivized sector only on marshland. Implementation of the Voru marshland detailed plan project recently examined in the RPI Estonian Project technical council requires outlays for land preparation (peat removal, landfill, draining and raising the land) and the establishment of technical networks beyond the capacity of this city. In many cities, by the way, this provides economic justification for the overhaul of quarters covered with old wooden houses.

In such a land crunch, builders of private dwellings in both Tallinn and Voru are offered building sites so far from the city or in such an unfavorable area that the number of applicants is declining. On the other hand, it should not be forgotten that during the last few decades tens of thousands of urbanites--precisely those for whom the erection of a private dwelling was not troublesome--have obtained a garden house or summer cottage for themselves. My pessimistic assessment is also supported by the figures: 417 private dwellings were started in the cities of our republic in 1981, but only 357 in 1983.

Dwellings in Decay

As everyone knows, the Estonian SSR is in first place among union republics in the degree of physical wear and tear on its cities' stock of dwellings. On 1 January 1984, 8.2 percent of the collectivized stock was unfit for use. By the year 2000, it will become roughly 22 percent of the current stock of dwellings. In order to improve and equalize the living conditions of the residents, it is absolutely necessary to increase the scope of demolition.

It is sometimes claimed that this is impossible because the all-Union directives call for a limit on demolition capacity. But these deal with all the good, habitable dwellings. The demolition of barely habitable lodgings is another matter entirely. What would the extensive demolition of run-down houses provide?

In the center of cities, in the so-called former suburbs, extremely valuable land would become vacant. It would be made possible, to some degree, to prevent the cities from becoming farmland and areas which are unsuitable for construction. Therefore, on the basis of detailed plan projects which take into account scope and milieu, the reconstruction of old city sections with more expensive buildings no more than four stories high becomes altogether cheaper than the buildup of new vacant areas. Operational expenses decrease, especially in the conveyance of drivers. I dealt with the problems of reconstructing old city sections in the article "Old Wooden Houses: to Be or Not to Be" (SIRP JA VASAR, number 46, 1983). But there is not much new to add. The outlined project for the suburban dwelling has already been discussed. Results of the contest for ideas for the suburban house's facade organized by the Tallinn City Executive Committee and the Estonian SSR Architects' Union will be made public in April. Several jury members should comment on them.

Pelgulinn [Suburb of Tallinn]

The possibilities for reconstructing the Pelgulinn dwelling district were studied in 1984 by the RPI Estonian Project with the help of meritorious specialist and engineering candidate A. Kull. The area enclosed by Roo, Telliskivi, Heina and Kolde streets is in particularly poor condition. Precisely here began the housing for the Pelgulinn workers' district when the railroad ran from St. Petersburg to Tallinn. The zone's typical dwelling is a kitchen with one or two small rooms. From the corridor one enters the kitchen, from there into the room. The first room of a two-room apartment gives access to the second. There is no additional space. A common water closet intended for the entire floor is located in the main corridor.

Small two-story houses were built in Pelgulinn by the cooperative "One's Own Hearth" in the 1920s and 1930s; larger, separate stone buildings were also erected. The prevalent type, however, was the wooden house two or three stories high with a stone stairwell, where the allotment of space was noticeably better. It is true that all of them were heated by stove, and a bathroom was lacking or built in the cellar for common use. The water closet was even placed in the entranceway. The cosy ensembles on Saue, Preesi, Aarde, Kolde, Maisi and other streets were put together with relatively simple contrivances. Housing construction expanded into the northern section of Pelgulinn during the years 1945-1960. In addition to stone houses, shield houses with wooden frame and rubble walls were also built. Construction activity came to a halt in the 1960s: Pelgulinn was covered with buildings.

Most of the Pelgulinn wooden houses belong to principal group VI. They are houses with outer walls, horizontal beams and double vertical beams whose standard lifetime is long over. Replanning such dwellings and putting them into good condition with extensive repairs are not justified. Extensive repairs on wooden houses with stone stairwells can be considered economically valid. But it is not possible to obtain an equally good level with new dwellings. And the question still arises: who will repair wooden houses when the dwellings of Mustamae impatiently await overhaul?

The level of physical and moral wear and tear on the dwellings, the expediency of extensive repairs, the architectural value of the buildings, and the city's general construction plans (the buildings which remain after expansion of the Paldiski highway) are taken into account during determination of the demolition capacity.

On the basis of our work it became clear that 71,500 square meters or 33 percent of the total dwelling surface in Pelgulinn should be demolished. Approximately 150,000 square meters of so-called suburban housing can be placed on the lots which become vacant. In the present circumstances, about 4,600 persons from the houses to be demolished must be relocated.

Concerning demolition and the relocation of dwellers, I would like to observe that here, unfortunately, the situations in which the persons live are not taken into account or distinguished.

Apparently, the inhabitants of former workers' barracks gladly agree to move from their small apartments in Kalamaja, Kopli, Pelgulinn and elsewhere to Lasnamae. Especially in Kesklinn, however, there stand a lot of wooden houses which were built for the rich before the Revolution. Though in a generally advanced state of wear and tear, the apartments in many of them are large, there are parquet floors, decorative ceilings, fireplaces, high rooms, and a bathroom. Stove heating is inconvenient, to be sure, but it does guarantee good heat and moisture control. Moving from such an apartment in the heart of the city to a small new apartment on the edge of the city is inevitably linked with the loss of one's furniture and other agelong property, with direct material and moral misfortune. We should obviously adopt a more flexible attitude toward the relocation of people.

The age and family structure of the dwellers of the old Pelgulinn district differs substantially from the city's average. The relative importance of preschoolers and schoolchildren is minor here, the special significance of those over 60 is, however, more than twice as great: the relative importance of single and two-member families is considerably greater, but the special significance of large families is more than twice as small as the city's average. Insofar as the possibilities for small, elderly families and individuals to obtain a new apartment are limited, the inhabitants of wooden houses are stable, growing old together with the buildings. Old people are unable, however, to keep in order the commonly used rooms of run-down dwellings, to contend with accidents and to heat dwellings properly. We can draw the conclusion that the placement of old people in old wooden dwellings speeds up deterioration of the latter. There is no alternative here, of course. If the old people do not have the strength, the young people do not have the inclination.

During the investigation of Pelgulinn it became clear that one of the key questions is sewerage. Right now the dwelling district is drained through the main sewer at K. Marx Avenue. A large part of the old street drainage pipes are often inundated and easily clogged. As a first variant, the engineers offered the establishment of a new tunnel collector and new separate rainwater systems. It would cost roughly 12 million rubles.

On the basis of the second variant, the joint-flow system is preserved and the run-down street drainage pipes are replaced. In order to assure normal outflow, a pumping station should be established at the intersection of K. Marx and Kolde avenues. The second variant would cost around 1.3 million rubles.

Even now, Pelgulinn is furnished with the chief social services. A rough analysis of investments made at our institute showed that in comparison with the new building districts the reconstruction of Pelgulinn proves to be competitive only in the event of the second sewerage variant.

Complex Timetable

Last year, in cooperation with the delegates of several institutes, a complex timetable was drawn up for the reconstruction of Tallinn's old dwelling sections. Unfortunately, it did not meet with approval in a single instance and turned to wastepaper.

The Tallinn RSN Executive Committee should now see to it that the suburban housing project does not come to a standstill. At the same time, one must proceed from a study of old suburbs to the formulation of detailed plan projects. Only with detailed planning do several theoretical problems finally reveal themselves, for example, the suitability of the new dwelling's parameters, the possibilities for preserving high refurbishing, the actual cost of reconstruction of engineering networks. Unfortunately, corresponding detailed plan projects have been eliminated from the institute's schedule this year.

Apartments' Arrangement

Suburban housing and reconstruction of old districts are linked, to a certain degree, with still another big urban construction problem: the correspondence between family structure and the number of rooms per apartment.

Ferroconcrete and stone dwellings must also meet the requirements of the future. At the very least, planning them with extensive repairs should be easily adjustable.

This problem has been dealt with in recent years by economic candidate V. Paul and K. Ehala, deputy director of the Tallinn Repair and Construction Trust.

It is completely feasible in the Estonian SSR that by the end of the century the population of our apartments could be such that the number of rooms is equal to the average number of family members. At the same time, persons living apart from the family (chiefly students and servicemen) could have a room in the older apartments. Adults who live alone could live predominantly in one-room apartments, likewise alone in dormitory rooms and boardinghouses. It follows from this that a family of four needs a four-room apartment, a family of five a five-room apartment. A family of four or five is, after all, a normal family which, from the state's standpoint, assures the renewal of manpower. Families of four and more today and in the future make up one-fourth of apartment occupants. But the stock of dwellings in our cities is comprised mostly of small apartments. In the apartment houses of Tallinn's collectivized sector, apartments of four and more rooms constitute 8.5 percent (in Narva, 4.1 percent) of the total number of apartments. According to K. Ehala's data, apartments built in Tallinn from 1960 to 1980 were divided up as follows: one room, 19.2 percent; two rooms, 44.9 percent; three rooms, 31.2 percent; four rooms, 4.5 percent; and larger, 0.2 percent. For the twelfth 5-year plan, the Tallinn RSN Executive Committee has ordered for its own construction an arrangement of apartments in which the special weight is given to four-room dwellings in slightly more than 6 percent. In other words, we are creating an apartment arrangement which does not correspond to the long-range requirement. It would thus be adequate on the surface, but a family of four would have to be given two small apartments, which often are not located side by side.

Why are they constructed this way then? The apartment arrangement is now determined on the basis of sequence I. In this case, however, small families dominate.

But those who must deal with problems of the future, with a strategy for housing construction, are utterly burdened with solving current issues. In order to untie this Gordian knot, it would be advisable, in our view:

1. To change the system of apartment distribution and redistribution so that big families are placed in the large new apartments, small families of the first sequence in small renovated apartments.
2. The entire stock of dwellings, new construction and the distribution of apartments should be concentrated in the hands of city authorities. In the larger cities, assessment of the entire movement of the dwelling stock should be done by computer.

Incidentally, concentration of the stock of dwellings in the hands of local councils is required by several all-Union decrees.

3. To increase the capacity for constructing apartments of four and five rooms. K. Ehala's calculations show that even by increasing their partial importance to 30-40 percent of the number of apartments to be built, it is impossible to assure the correct arrangement in Tallinn by the end of the century. I would further like to add that otherwise we should go in for not having children.

4. To make use of every opportunity to combine small apartments during extensive repairs. By combining adjacent one-room and two-room apartments we would get a four-room apartment in which there are two water closets and a storage room formed from the second bathroom. Unfortunately, though, they are not often placed side by side. A shortage of one-room apartments can also arise in this way. At present, there is a surplus only of two-room apartments.

5. To continue construction of small apartments in accordance with new projects which would make it possible to combine them easily in the future. We offered the suburban house as a cooperative dwelling. Other variants could be offered just as well, for example, a state dwelling plus cooperative garages. If only there was not a forest of laws standing in the way! In this case, the suburban house could be the first which would be planned and built as transformed. In sections of the rough outline for the suburban house, the apartment structure also offers opportunities for such. But at present one has not proceeded from the standpoint of possible transformation. There are still a lot of obstacles on the road to manufacture of suburban housing, and the road is long. It would now be seemingly necessary to examine both them and the unified housing project of the Tallinn EEK from the viewpoint of combining apartments.

By way of conclusion, I would like to ask forgiveness from the readers of the cities of Tartu, Parnu, Rakvere, Viljandi, et alia. The article has been drafted predominantly on the basis of the Tallinn example, but the problems are similar.

12327
CSO: 1815/49

CONSTRUCTION MACHINERY AND EQUIPMENT

FLEXIBLE MANUFACTURING IN RESIDENTIAL CONSTRUCTION

Moscow GIBKAYA TEKHNIOLOGIYA DOMOSTROITEL'NOGO PROIZVODSTVA (NOVOYE V ZHIZNI, NAUKE, TEKNIKE: SERIYA "STROITEL'STVO I ARKHITEKTURA") in Russian No 4, Apr 85 pp 1-15, 32-47

[Annotation, introduction, selected articles by Robert Vladimirovich Kryukov, doctor of technical sciences, professor and head of Production Procedures Department for Construction Designs and Materials of the TsMIPKS (Central Interdepartmental Institute for Raising Construction Supervisors' Skill Levels), attached to MISI (Moscow Institute of Construction Engineering imeni V. V. Kuybyshev): "The Producibility of Sets of Building Products and Flexible Manufacturing in Residential Construction", "Procedures for Renovating House-Building Enterprises, Taking Flexible Manufacturing Methods Into Account" (This article not included in excerpts.), and "Assimilation of Flexible Manufacturing in Fully-Prefabricated House-Building Enterprises", appended article by V. M. Masyutin, architect: "Columnar Foundations in Heaving Soils: Appendix "Let's Build It Ourselves", and table of contents of journal "Flexible Manufacturing in Residential Construction", Moscow: Znaniye, 1985, 23,910 copies, 48 pp]

[Excerpts] Annotation

Flexibility in residential manufacturing techniques is indispensable to the manufacture of a wide and varied assortment of industrial construction items, and hence to an improvement in the quality and expressiveness of our cities and villages.

This booklet examines the scientific bases and practical recommendations concerning the introduction of flexible manufacturing technology in residential construction projects, as regards both reconstruction and new construction.

Intended for lecturers and students of national universities, students and instructors of architecture and construction VUZ's and for designers and technicians.

Introduction

Completely prefabricated housing construction has become the basis upon which state plans for residential construction are being realized. At present, over 80 percent of Soviet families live in single-unit, well-arranged and managed apartments. In a relatively short time, a powerful production base has been organized in this country for the manufacture of combinations of structures and products used in housing construction: about 500 enterprises, with an

overall capacity of 59.5 million m² of total area. However, the present-day level of fully prefabricated house-building was not achieved all at once. The output of the first house-building enterprises, which were organized during the late 50's and early 60's consisted as a rule of single-unit type houses of fairly simple design and having a limited set of apartments (the I-464, K-7, 1-335 and other series), which were incapable of providing a full measure of solutions to city designing and building, and architectural problems, even then. There were two reasons for this situation. On the one hand, the housing fund, which was demolished during the Great Patriotic War, required speedy rebuilding: it was necessary to provide housing for a large portion of the population. As a matter of course, the tasks of architectural diversity in populated areas and cities were moved into second place in order of importance. On the other hand, at the first stage of the development of fully prefabricated large-panel house building there was simply not enough necessary experience or know-how; our country was a pioneer in this field. We had to devise new methods for designing buildings using large-size prefabricated elements, methods of producing structures and components in plants and procedures for assembling them at the construction site. We had to develop a large number of new designs in a short time, first and foremost structural and production designs. In these conditions, it was difficult to set up plant production of a wide and interchangeable assortment of products and components having a variety of trim details, necessary for the creation of architectural variety in the buildings.

As improvement in large panel house-building has continued to develop, both house-building output and plant and construction industry production techniques have matured. Successive generations of large-panel houses acquired more variety in their floor-plans, improved designs, and a variety of decorative trim. We entered a new stage of residential housing construction here. In the CPSU Central Committee and USSR Council of Ministers decree of 28 May, "Measures for Improving the Quality of Residential Housing Construction", tasks were set for a radical improvement in fully prefabricated residential housing construction, i.e. improving its effectiveness, and a radical improvement in quality, including the quality of its architectural resolutions. Improving construction efficiency called for a reduction in the labor intensiveness and materials consumption of construction by improving the design of the buildings, and by improving production methods and the equipment used in plants and in the construction industry. Improving quality meant improving the layout of the apartments, expanding their products lists, and improving the buildings' operational indicators by improving the utility lines, the interior trim and finally, the civil construction and architectural resolutions of the areas being built up. All this was meant to solve a critical social problem--that of more completely satisfying the workers with comfortable and attractive housing.

October 1981 saw the acceptance of the USSR Council of Ministers' decree "Measures for Improving the Effectiveness of Capital Investments Allocated for Housing Construction", and the CPSU Central Committee decree of February 1983, "Measures to Insure Fulfillment of Housing and Social Facility Construction Plans". These government resolutions set the task of further increasing the volume of mass construction of fully prefabricated building projects--

housing, children's facilities, schools etc. before the construction industry, and this included improving the quality of their architecture and construction, hence, enhancing the producibility of the model projects, and introducing flexible production methods in the house-building enterprises.

In the field of the house-building industry, THE PROVISION OF ARCHITECTURAL VARIETY IN FULLY PREFABRICATED BUILDINGS IS CONNECTED WITH THE PRODUCTION OF A SUFFICIENTLY WIDE AND VARIED ASSORTMENT OF STRUCTURES WITH VARIED CHOICES OF TRIM DETAILS. Only thus will it be possible to develop full-value urban-development and architectural resolutions. Execution of the set tasks has called for intensive work on the part of scientists, designers and builders, the results of which have regrettably heretofore not been used in full measure in construction practice.

In spite of the success of industrialized large-panel house-building in a number of cities in the Soviet Union (Vilnius, Tallin, Dnepropetrovsk and Minsk) and settlements in the Kostroma, Kalinin and Saratov and other oblasts, where attractive residential developments which have been awarded high-level government prizes have been built, for today the quality of large-panel house building around the country as a whole leaves much to be desired. As they always have, the enterprises produce two or three types of apartment houses, all having the same trim details. The sectorial average for use of their production base capacities comes to 0.79 in all. The majority of house-building enterprises operate inefficiently. Labor-intensiveness in the production of sets of products at lagging enterprises has fallen to one third to two-sevenths of that at leading enterprises. The sectorial average indicator of total labor-intensiveness (construction industry plant) is two-thirds to one-half that of the leading foreign companies.

Undoubtedly, organizational difficulties play a significant role in the factory bases lag in fully prefabricated house-building: disruptions in the supply of basic materials and order-completing components, the entry of materials changes under incorrect headings, the insufficient numbers and turnover of the work force, putting enterprises into operation sequentially etc. However, the main cause remains IMPROPER ORGANIZATION IN HOUSE-BUILDING PRODUCT DESIGN WORK, AND IN THE ENTERPRISES' PRODUCTION METHODS AND EQUIPMENT USED IN THEIR MANUFACTURE. The result on the one hand was that apartment house and block designs turned out to have too little relation to the methods by which their parts and components were manufactured, and on the other hand the production methods and equipment used by the house-building enterprises turned out to be unable to give full value in solving urban development and architectural problems. Specifically, this was expressed by the fact that the house-building industry was unable produce the needed assortment of products needed in the construction of large-panel apartment houses of varying numbers of stories and area, with varying configurations of their floor plans and alternative frontal trim. The house-building enterprises generally made no provision for their sections to put out small lots of architectural details and attractive exterior elements, without which it is impossible to develop residential areas and cities which are fully up to standards. In other words, the architects and technicians ceased to understand each other.

We have already said that one of the causes for the quality of fully prefabricated house-building being still so low lies in the fact that this new type of construction has had an inadequate theoretical basis and inadequate systematic supply. The specialists who worked in this field accumulated their experience on the job. However the loss of mutual understanding between the architects and technologists was also a result of an artificial breaking up of the area of designing apartment houses and residential blocks and that of planning a plant and construction base for constructing these projects. The type designs for the large-panel apartment houses and residential blocks were, as a rule, developed by specialized central, zonal and regional institutes. They executed these designs completely--right up to the working drawings, and sent them to the technological planning organizations which, based on these designs, developed the production procedures and equipment for the house-building enterprises. Following this, a standard headquarters plant was built. After troubleshooting the production methods and equipment, the number of the enterprise's designs to be printed and used for mass construction of large-panel buildings is set. In this way, all the stages--from conception of the buildings' designs to their realization--are executed by different organizations and are checked by different departments. Designing of the architectural and construction portion is generally carried out by Gosgrazhdanstroy [State Committee for Civil Construction] institutes and by union republic state committees for construction affairs institutes, as well as by local urban planners etc.; the production planning is carried out within the USSR Minstroydormash [Ministry of Construction, Road and Municipal Machine Building] and construction ministries system; equipment manufacture and operation of the enterprises is handled by the construction ministries (Minstroydormash delivers only a small part of the standardized equipment). All this takes an average of 10-15 years. During this time, both the apartment house (residential blocks) designs and the manufacturing methods used in their plant production become obsolete.

Recall, that all of the outstanding architectural achievements have resulted from the organic interrelation of design resolutions and the production methods used to realize them. Both of these stages used to be carried out by one and the same foreman (the "architect" acted both as designer and builder). Thus, the brilliant Renaissance painter, sculptor, architect and engineer Michelangelo Buonarrotti not only decided on the engineering solution for the dome of St. Peter's Cathedral in Rome and executed its architectural and sculptural design, but he oversaw its construction as well. There are many such examples in the history of architecture. To be sure, at the time, and on that level of construction technology, a single very talented person could solve all the problems of designing and realizing a building or a structure.

These days, even a comparatively simple building, such as an apartment house, has become incommensurably complicated with regard to engineering. More than 20 different specialists participate in finding solutions to all its architectural and technical problems. And their efforts have to be coordinated and supplied in such an orderly manner that the unity of the architectural concept and the realization of the method by which it is produced are not disrupted, and so that the needed architectural and construction quality are achieved at the lowest possible cost. And this can only come about when the

entire volume of design work with its many plans is done by specialists in associated fields according to an integrated time-table which also takes the correcting of the architectural, design and production requirements into account, as done in industry.

It is significant that successful resolution to architectural and urban design and construction problems with accompanying high technical and economic indicators in the plant and construction base has been achieved in precisely those cities where the operation was organized in integrated fashion, with mutual consideration made for the architectural and production requirements. Architects from Vilnius, Tallin, Dnepropetrovsk and Minsk made a careful study of the methods used in building prefabricated buildings and components as well as the specific nature of the production methods and equipment used by the enterprises upon which they are made, and then devised their own designs, making maximal use of the industry's potentialities. For their part, the manufacturing engineers gave hints to the designers on ways to solve their problems with the lowest production cost. And in spite of the fact that this, their collaborative effort, was provided with an insufficient theoretical and orderly basis, its results and achievements are available. For their architectural work in the new rayons of these cities, the designers and production workers were awarded the Lenin Prize and the USSR State Prize.

At the present time, sufficient experience has already been accumulated, and a complete series of procedural documents have been developed regarding the designing of fully prefabricated buildings and the methods for their plant-based and construction site production, all of which provide solutions to the architectural problems, with the necessary efficiency of construction. Below, we shall discuss the basic principles for carrying out an entire complex of design efforts, and the principles used in the operation of house-building enterprises, based on reasonable compromise in the design resolutions for fully prefabricated apartment houses and in the methods used in the production of sets of their products and components. All these factors are guaranteed by IMPROVING THE PRODUCIBILITY OF DESIGNS FOR APARTMENT HOUSES AND RESIDENTIAL BLOCKS THROUGH THE USE OF FLEXIBLE MANUFACTURING AND ORGANIZATION OF PRODUCTION. The necessary recommendation and procedures were developed by the TsNIIEP [Central Scientific Research Institute for Experimental Residential Planning] with the assistance of MISI imeni V. V. Kuybyshev. In addition, we will give specific examples of how the elements of flexible manufacturing have been developed in some of the country's individual house-building enterprises.

THE PRODUCIBILITY OF COMBINATIONS OF BUILDING PRODUCTS AND FLEXIBLE MANUFACTURING IN THE HOUSE-BUILDING INDUSTRY

The effectiveness and quality of fully prefabricated and in our case large-panel residential construction depend on the producibility of combinations of products and components for a series of apartment houses and the flexible manufacturing utilized to produce them.

The producibility of combinations of items and components (producibility of designs) indicates THEIR SUITABILITY FOR STRAIGHT-FLOW MANUFACTURING PROCESSES WITH CONSIDERATION MADE FOR CHANGES IN THE MAKE-UP AND NUMBER OF ITEMS AND COMPONENTS IN THE COURSE OF PRODUCTION. The producibility of apartment house and residential block designs provides methods for organizing architectural, designing and manufacturing project planning; it provides methods for unifying and standardizing the architectural project planning and design parameters for the apartment houses and their products and components as well as the corresponding parameters for the plant and construction-site base; it provides methods for insuring the producibility of the list of manufactured products as well as that list of items to which the enterprise changes over following renovation or re-equipping.

Flexible manufacturing and the organization of residential construction imply the sort of organizational and technical solutions which provide for the PRODUCTION OF A WIDE AND VARIABLE (within designated limits) PRODUCTS LIST OF ITEMS AND COMPONENTS WITH NO SHUTDOWN OF PRODUCTION AND NO REDUCTION IN CAPACITY. Flexible manufacturing means, first and foremost, an enterprise's manufacturing equipment resources, its stock of concrete-pouring forms, its working areas and a number of other factors which permit the manufacture of a variable products line with no break in the rhythm of the production lines' operation, and consequently, no reduction in the enterprise's productive capacity, with all of the foregoing economically based on a calculated time period. For this purpose, the manufacturing method and the equipment must be all-purpose (within set limits), so that they can be readjusted to produce one or another type of product.

Flexible manufacturing is not a new concept. It has found wide use in light industry and electronics, as well as in the motor vehicle and other sectors of industry. This type of manufacturing is especially needed by those sectors of industry the output of which is frequently updated (because of technical requirements or the demands of fashion, such as, for example in light industry). At present, there is no longer anyone who is amazed by the extremely wide assortment of such goods as television sets, radios, tape recorders and watches which are produced in the most varied assortment of styles (depending on customer demand), but all on highly mechanized or automated production lines. The technical qualities of the products manufactured by enterprises using flexible manufacturing methods change in accordance with the requirements of technical progress, within economically justified periods of time, as well as in accordance with the consumers' requirements, and as often as demand requires. The upshot is that the stable parameters for this sort of production (circuit diagrams, designs, motors) remain unchanged for quite a while--until such time as it becomes economically justifiable to replace them with more up-to-date products, and parameters such as shape, color and trim details etc. are changed over for those which are more current, thereby providing for the varied demands of the consumer. Thus television sets of like class are made using standardized schematics, have standard units and their production is stereotyped and carried out on highly-mechanized and automated production lines, though the sets are different as regards their external appearance.

If this principle is applied to the prefabricated structures of apartment houses, then it turns out that quite a number of parameters, primarily structural (reinforcing of the ferroconcrete items, their thickness and joints, staircases, sanitary engineering stalls, ventilation units etc.), can remain the same for quite a long period of time, and can and must be identical for designs for apartment houses in a single climatic construction zone. Changes in these parameters are associated with change in the social requirements which effect the standards for living space, comfort (sound and heat insulation) etc. The frequency with which the stable parameters are changed is not great--in a number of instances it coincides with the period of time it takes for the enterprise's production equipment to wear out. But the parameters which determine the number of stories in the buildings, their configuration within the plan, their frontal details and their trim, their finish work and exterior improvements should change as often as required by architectural or urban planning decisions.

In 1975, in issue No 5 of this same series, we discussed flexible manufacturing in residential construction at the level of knowledge at which this problem was found at the time. Work on the problem continued in the Central Scientific Research Institute for Experimental Residential Planning and other scientific research organizations. An entire series of procedural documents which developed and defined more precisely some previously developed positions were worked up and checked in practice. These documents established prerequisites for the widespread assimilation of flexible manufacturing at house-building enterprises involved in new as well reconstruction projects.

Two groups of problems enter into flexible manufacturing in residential construction:

1. The industrial preparation of the products list of products earmarked for production at a single enterprise within prescribed limits of changeability, including:

- a) the selection or development of a series of fully prefabricated buildings to be constructed in a specific region by personnel from specific enterprises;

- b) the industrial treatment of the list of products used in fully prefabricated buildings, with consideration made for the manufacturing method and the organization of production of one or the other of their sets of products at individual enterprises;

- c) the procedure used for standardization and classification-by-type of the parameters for the products list with account made for plant and construction-site manufacture;

- d) the procedure for insuring the producibility of the products list used in flexible manufacturing methods, including during conversion to a new generation of type designs for apartment houses and residential blocks.

2. Organizational, technical and administrative resolutions of the production processes and production equipment of enterprises which manufacture a wide (changeable within prescribed limits) list of products. They are structured on the following principles:

a) the putting into effect of plans for organizing production using flow-type production lines in the manufacture of one or another type of mass-produced products, which type of production will provide for changing (within prescribed limits) their product sets with no disruption in the rhythm of the flow-line;

b) the utilization of production equipment and all-purpose readjustable forms, which provide for the manufacture of their production at a prescribed rhythm using a set inventory of forms for a variable (within the limits of the factory catalog) set of products;

c) control of production and reserve stocks of product sets, which control will provide for their production at the needed volume and assortment at minimum cost;

d) a choice of manufacturing methods and production operations, which provide for rhythmic production of a wide and variable line of products

Theoretical and practical recommendations concerning all the above-enumerated problems were developed at the first of the production lines utilizing flexible manufacturing processes--at Penza, Leningrad, Vologda, Lipetsk and Nizhnekamsk, and checks were made in the Central Scientific Research Institute for Experimental Residential Planning, in Giprostrommash [All-Union State Planning Institute for Precast Ferroconcrete Construction Machine Building], the KB [Design Bureau] for Ferroconcrete imeni A. A. Yakushev, in Lenproyekt [Leningrad Institute for Residential Housing Construction Design] and in the zonal institutes attached to Gosgrazhdanstroy [State Committee on Civil Construction and Architecture]. Procedural documents are presented in the latest edition of "A Collection of Recommendations and Procedures for Project Planning for New Construction, Renovation and the Technical Re-Equipping of Operating Large-Panel House-Building Enterprises, With Regard to the Initiation of Production of a Widely Variable List of Components", published by the Central Scientific Research Institute for Experimental Residential Planning in 1982. As is evident from the collection's title, the documents contained therein are also designed for enterprises which are subject to technical re-equipping or renovation.

The need for flexible manufacturing and organization of production at working large-panel house-building enterprises which undergo systematic technical re-equipping or renovation every 5-10 years, stems from the following reasons.

Predictions of the growth dynamics of plant base capacities for fully prefabricated house-building show that their primary volume of work, using new type designs for apartment houses and residential blocks will be provided in upcoming five-year plan periods mostly as a result of the technical re-equipping and renovation of operating enterprises as opposed to building new enterprises.

This general trend was determined by the 25th and 26th CPSU congresses and an entire series of directives. Hence, the technical level of the construction plant base as a whole and its potential for accomplishing construction and architectural tasks will depend on the technical policy regarding the procedural and organizational provision of technical re-equipping or renovation, as well as on the operation of the enterprises for fully prefabricated house-building.

At the same time the conditions for an operation such as this are quite complex. About 500 operating house-building enterprises are under the jurisdiction of 25 ministries and departments. The capacities, manufacturing methods and equipment of the majority of the enterprises are different (a result of both objective and subjective causes). In the first group of these causes we find differing periods of time for construction and for putting enterprises into operation, differing requirements for basic raw materials, finishing trim materials, differing climate-related construction and design resolutions. Thus in Orenburg four house-building enterprises manufacture four series of apartment houses, and there is no standardization, even where it has been unconditionally approved, i.e. sanitary engineering, ventilation units, staircases etc. Examinations conducted by TsNIIEP showed that the country's house-building enterprises are producing four types of sanitary engineering stalls, 33 brands of electric panels, 98 brands of staircase landings, all for a single generation of designs; the Series 83 plants in the cities of Brezhnev, Volgograd etc., which produce identical products, use different production methods and equipment.

All this leads to the conclusion that each enterprise needs to work up its own plan for technical re-equipping or renovation. According to the ministries' plans, about 50-100 enterprises are subject to these re-equipping-renovating plans every year, which means that the volume of design work is so great that it takes about 200 design organizations, the majority of which are not themselves specialized, to carry it out. Up to now there has essentially been no coordination or systematic leadership of these organizations. This gives rise to serious miscalculations in production, as well as to mistakes which result in planned deadlines for development of production capacities not being met, and to ineffectiveness in the operation of the enterprises. The operation of these enterprises without flexible manufacturing limits their architectural potentialities during the building up of new rayons and results in low product quality and low quality in overall construction.

Technical re-equipping and renovation of these enterprises means the economic expenditure of capital outlays, including by partial utilization of equipment which is not yet worn out. That is why the dissimilarity in production methods and equipment which has come about in the enterprises can be reduced only by stages, and by using an economically approved standardization. The type houses and residential block sections which will be produced by these enterprises will have to be suited to their production methods and equipment, and this will require that the plans be polished and reworked. First of all this concerns the working drawings of the plant products catalogs. The makeup of these drawings is determined by the long-range construction plans for fully prefabricated buildings in a given area. This kind of work is already in

progress . . . thanks to the efforts of local planning organizations: having taken a series of the central designing institutes as their foundation, they are "binding" them to the local urban development conditions and to the production methods used by specific enterprises. The volume of these additional designing efforts is sufficiently great that at times it even reaches the detail design stage. There are successful examples of this kind of reworking (in Vilnius, Tallin, Dnepropetrovsk and Lvov), but unfortunately there also exist not-so-successful examples.

Thus in the conditions with which we are faced, a successful resolution to the urban development and architectural problems in the field of mass fully-prefabricated construction depends on the correctly organized cooperative efforts of those who are developing the project plans for technical re-equip- ping or renovation of specific house-building enterprises, and those who plan the apartment houses, residential block sections and plant products catalogs for these enterprises. Obviously the effort to standardize the architectural planning, design and production resolutions has to be done simultaneously and in parallel, so that their differences can be limited to within reasonable limits while at the same time reducing the number of series and the list of products within each series. It seems that in conditions such as these, the central and regional planning institutes ought to solve the fundamental prob- lems involved with the architectural lay-out resolutions of the apartments, with the system for standardizing the design resolutions and the products, their combining, the quality level etc. in association with the fundamental problems of industrial supply (also, examples can be shown where these reso- lutions have been utilized at specific construction sites). These local planning organizations, by applying these data, can jointly develop specific series of project plans for apartment houses and residential block sections along with the production methods and equipment of renovated enterprises by using the procedural data and by consulting with the central and regional institutes. This approach permits the equipment, forms and even (in a number of cases) the production lines to be standardized, permits reductions in the volume of non-standardized equipment, in production and design planning, and permits series-production planning volumes to be expanded. All this will bring about a simplification and cost-reduction in the technical re-equipping or renovation of these enterprises.

However, technical re-equipping or renovation take time, and that is why they should be done an element at a time, incorporating production methods and equipment designed to produce standardized structures for prospective series, in enterprises which are even now being renovated (and where this is not associated with great difficulties and/or outlays of capital). At present these series are being developed by Gosgrazhdanstroy institutes as part of the architectural-design-production systems. This effort can be organized both on the basis of long-term integrated programs with the assistance of the central and regional institutes which are carrying out scientific research, development and planning of new generations of series of type designs, as well as on the basis of planning central and regional production organizations which are responsible for formulating technical policy in plant-based resi- dential construction and specific planning enterprises. Goal-oriented inte- grated programs which are based on corresponding ministry and departmental

programs can be authorized and monitored by Gosgrazhdanstroy, which provision was mentioned in the CPSU Central Committee and USSR Council of Ministers decree of 28 May 1969 (in which leadership of the matter of planning residential and civil buildings was emplaced, as well as the coordination of planning for urban development enterprises independent of their departmental affiliation). TsNIIEP (Residential) has already developed programs like these with USSR Minvostokstroy [Ministry of Construction in the Far East and Transbaikalian Regions], USSR Minsel'stroy [Ministry of Rural Construction] and Glavmosoblstroy [Main Moscow Oblast Construction Administration] attached to Mosoblispolkom. They have been approved by Gosgrazhdanstroy and the above-indicated ministries, and are being successfully carried out.

Recall once more that at present we need to introduce the recommendations and procedures contained in the above-mentioned collection as quickly as possible. These documents have already undergone a practical check both in the planning organizations and in production. They should be disseminated within the planning organizations and to the house-building enterprises to train workers in their correct usage.

PROCEDURES FOR RENOVATING HOUSE-BUILDING ENTERPRISES, TAKING FLEXIBLE MANUFACTURING METHODS INTO ACCOUNT (Article not included).

ASSIMILATION OF FLEXIBLE MANUFACTURING IN FULLY-PREFABRICATED HOUSE-BUILDING ENTERPRISES

[Text] In our country at the present time there are a number of house-building enterprises within which elements of flexible manufacturing have been introduced.

THE NIZHNEKAMSK AND LVOV DSK'S [House-Building Combine]. Both of these enterprises manufacture complete sets of products for large-panel apartment houses and Series 84 residential block sections, developed by the TsNIIEP Zhilishcha [Central Scientific Research Institute for Experimental Residential Planning]. The production lines used at the Nizhnekamsk DSK for the wholesale manufacture of their basic products were also developed at the TsNIIEP Zhilishcha. All of the production lines use standardized equipment and forms, and are built in the form of vertical enclosed stands. The same stands are used at the Lvov DSK with minor changes.

Series 84 differs, in that it uses modular mesh to insure size coordination in the basic structural elements used in apartment houses. An enlarged 1,200 X 1,200 mm module is used, which limits the number of product types manufactured, and thus sets up a stable catalog of them, the use of which allows this series to be developed further as well (alternative large-panel apartment houses have been developed for future use, which have greatly improved layouts and architectural solutions). The catalog's stability permits the house-building enterprises to operate for prolonged periods of time without having to renovate, while changing over to the more improved types of apart-

ment houses. Here, flexible manufacturing is also needed in the manufacture of varying sets of products within the scope of the overall catalog, depending on one or the other set of apartment houses under construction.

TsNIIEP Zhilishcha has also developed a plan for a specific list of products for the apartment houses and residential block sections in use in Nizhnekamsk as well as a corresponding catalog of products. The plan for a products list of apartment houses and residential block sections to be built in Lvov has been developed on the basis of the very same catalog by the Lvov State Planning Institute for Municipal Construction (in consultation with TsNIIEP Zhilishcha). The practice in operation at the Nizhnekamsk and Lvov house-building combines has corroborated the potentiality for developing architecturally varied apartment houses using an identical products mix: the apartment houses and residential block sections in Nizhnekamsk and Lvov have no external resemblance one to the other (see cover photographs, pp 1 and 2).

The distinctive feature of the production lines (two-stage stands) of the Nizhnekamsk and Lvov house-building combines is the availability of the all-purpose readjustable forms with their separable sideboards. The forms consist of a bottom plate and the heavy-duty sideboards which are movable for joining to the bottom plate; detachable boards, which determine the geometric dimensions and configuration of the facing pieces are attached to the sideboards. The articulated mounting of the sideboard elements to the bottom plate complicates the form design with regard to manufacturing exterior wall panels of complex configuration in their facing surfaces (since here the lower portion of the board which determines the configuration has to be attached to the bottom plate); at the same time, the kinematic diagram of these forms simplifies both their manufacture and their operation.

At the Nizhnekamsk DSK the plan also provides for stations from which to readjust the forms, but according to quite a number of organizations, the reasons for these stations have not been fully realized, and this is why the forms are not readjusted at their specially removable sections, but rather at the working areas, which are right next to the production lines. In spite of this, practice at the Nizhnekamsk DSK has confirmed the feasibility of readjusting the all-purpose forms during one or the other times when the products are spread out (within a single group of products), for which the given form was designed. Time and motion studies have established that the maximum time needed to adjust the forms, using the work force from two shifts of fitters with the greatest volume of work (removal and installation of the contour-forming sideboards and aperture-forming elements) amounts to no more than two hours. Using the special readjustment stations equipped with the appropriate attachments, the maximum time needed for readjustment will be substantially reduced.

The identical form design has been in use at the Lvov DSK, where they obtained approximately the same data for time spent in readjusting the forms. No form-readjustment stations were provided for in the manufacturing plan at the Lvov DSK. According to a supplementary design drawn up by the TsNIIEP zhilishcha manufacturing division on the instructions of the Lvov DSK, these stations are emplaced on a specially built-on span.

In spite of the fact that neither of the enterprises uses flexible manufacturing to full capacity, they have used their all-purpose readjustable forms to manufacture block sections in quite a wide products list, and this has brought about a valuable architectural build-up. The Nizhnekamsk DSK is presently manufacturing seven block sections, with six being produced by the Lvov enterprise. Both enterprises' production capacities have been developed in compliance with the plan, and their technical and economic indicators are on a par with those of the leading house-building combines.

THE PENZA HOUSE-BUILDING COMBINE. The Giprostrommash Institute has developed a flexible manufacturing technique for this enterprise as well. The basis for the manufacturing plan, just as in the previous cases, lies in the use of conveyor lines to manufacture the products horizontally, and underground slotted heat-treatment chambers. Also in use is a scheme which organizes production with branching flow-lines. This creates time reserves, used in the most labor-intensive processes and when readjusting the forms. The forms used here are also the all-purpose type, but in contrast to those used at the Nizhnekamsk and Lvov DSK's, their boards are hinged. The same design feature is used on the boards themselves (the base boards, which employ an articulated joint to the base plate, and the contour-forming boards which are attached to them). The Penza DSK operation has confirmed the effectiveness of using flexible manufacturing on production lines, just as tests of the all-purpose forms have shown that they can be quickly readjusted. In the new type designs for production bays, where production lines will be located for the manufacture of exterior three-layered wall panels, Giprostrommash has made provision for readjustment stations equipped with all necessary instrumentation and accessories, a cantilever crane and also storage for interchangeable equipment.

The Vologodskiy DSK is a building-module house-building enterprise which has used the flexible manufacturing method for eight years already. Time has proven the fitness for work and reliability of its equipment. This is the sole enterprise where all type-sizes and grades of building modules used in the construction of five-story apartment houses are manufactured on a single conveyor-type molding machine. TsNIIEP Zhilishcha has developed the plans for a series of apartment houses and for the production line on which they will be manufactured. The Mosbazzgiproshakht [possibly Moscow Basic State Institute for the Planning of Mines] Institute is the enterprise's general designer.

The conveyor line which is used to manufacture the building modules (without the floor slabs--the so-called "caps") is made up of: one molding unit for concreting the "cap" of the walls; at the conveyor's next station there is a molding unit for concreting the "cap" ceiling slab (floor slabs are manufactured on a separate conveyor line); two transfer cars; two lines for heat-treating the products; a station where the forms are removed and a station where the form cores are readjusted.

The molding station has been worked out (see back inside cover, p 3--picture not shown) in a fashion which will permit the molding bunker and the exterior mold panels to be rearranged to a number of sizes with a module of 30 cm. The

core is of unchangeable design and determines the type size of the "cap". The longitudinal exterior mold panels are of the building module's maximum size, and can be arranged in a number of positions; the transverse mold panels are made up of elements which allow the width of the module to be changed.

The molding machine, which operates like the movable mold panels, consists of a hydraulic core hoist and a system of vibrating hoppers with hydraulic positioning drive; it can be quickly adjusted to the same size as whatever core is on the molding station at any given time. Changes in the grades of building modules are made with the help of the interchanging equipment affixed to the core. The opening-forming elements are attached to the lower panel element with quickly removable connectors as are the other equipment elements. The products are heat treated on two lines with the heat-transfer agent (steam) fed to the interior of the cores and into the unit's exterior slabs. In this connection, the slab upon which the production line operates is covered with a special shield.

THE GORKOVSKIY DSK. This enterprise has made provision for full-volume flexible manufacture in residential construction. The Gorkovskiy DSK is the country's major enterprise involved in the manufacture of complete sets of products used in the construction of apartment houses and residential block sections of varying design, as well as mass-produced buildings used for cultural and general purposes. First and foremost, this enterprise has been designated to construct the Meshcherskiy Island EZhK [possibly High-Rise Residential Complex] which is being built as a collaborative USSR-GDR experiment (a similar EZhK is being built in Magdeburg). The client for the Meshcherskoye Island EZhK construction project is the Gorkovskiy gorispolkom, with that of the DSK being USSR Minstroy [Ministry of Construction], the general designer for the EZhK is TsNIIEP Zhilishcha, with the USSR Minstroy's Gorkovskiy Promstroyproyekt [Industrial Construction Planning Administration] acting as the production plant's general designer. The production procedures and the technical and economic portion of the plan, the KIP [instrumentation] and automatic equipment used in the production processes, as well as the non-standardized equipment were all developed by the TsNIIEP Zhilishcha's production division.

The block sections and apartment houses for the EZhK are in compliance with specific urban development and compositional conditions. The following block-sections are being used here: 9-, 12- and 16-story row buildings oriented to the east and west, and to the south with angular 9- and 16-story buildings designed to face in various directions; 9- and 12-story structures turned (at angles of 135° and 225°) with an east-west by south orientation; block sections with public services on the lower stories; with alternating 6-, 8-, 10- and 12-story apartment buildings; terraced block sections (in rows and turned) by which steep inclines might be created; and a 25-story apartment building for smaller families. The design calls for one-of-a-kind panels on the exterior walls, of triple-layer construction with flexible stays, expanded-clay lightweight concrete panels for the non-rolled material roof, for construction of the thermal garret, a new type of building module for use in the sanitary engineering stalls, large-size perforated floor panels, calibrated for thickness, and which use less reinforcing steel, triple-glazed, triple-pane windows, and interior wall panels with frameless door openings.

The DSK design calls for use of a rational layout diagram for the master plan and the enterprise's main building which calls for shortened transport routes and reduced working areas. The bays have been specialized to comply with the basic types of mass-produced products and are equipped with new highly mechanized conveyor production lines. The products are not only molded on these lines, but are in essence finished up and made into sets as well. A special system for automated control of production, reserves, product transport and construction has also been developed. All types of components, other than sanitary engineering stalls and interior walls are manufactured on uniform horizontal conveyor lines with all-purpose molds from a design by TsNIIEP Zhilishcha and with underground heat treatment rooms. Provision has been made on all lines (where needed) for flexible manufacturing and organization of production. Let us consider by way of an example a production line for exterior wall panels (Picture 4.).

The exterior wall panels in the EZhK's buildings are done in bas-relief, and come with six trim alternatives. The production line is of the multistation conveyor type, branched where there is a concentration of operations connected with diversity in the items produced and needing corresponding reserves of time. The set-completing materials and fittings are delivered from the auxiliary shops to the production lines on mounted conveyers. In the area where the forms are struck from the products, there is a transfer car which is part of the conveyor line. This car takes the form from the form-striking station to one of two readjustment stations, taking care that the form which is on the second station, where all readjustment work has already been completed, quickly (within the limits of the conveyor's speed) takes the place of the form just removed from the conveyor. Thus the length of time a form stays at the readjustment station is determined by the amount of time during which the form needed for the readjustment operation is approaching the form-striking station. In order for this time period to be reduced as much as possible, the readjustment stations have been equipped with a special hoisting unit--a cantilever crane which is used along the column reinforcing mesh production lines, and which connects the readjustment posts to the mechanized replacement equipment storeroom. This equipment storeroom is made of scaffolding placed by the shop columns and which is supplied by the stackers used for storing and fetching any item of equipment. All the mechanisms needed to dismantle the forms as well as to remove and install their replaceable parts are found at the readjustment stations. This is precisely where the instrumentation for checking the geometric dimensions of the assembled forms is concentrated. In order to manufacture exterior walls having variations in their finish trim (tile facing, exposed patterns and decorative layers combined with relief-forming patterns) the needed storage places for trim materials and tools have been provided for on the conveyor and on its corresponding sections.

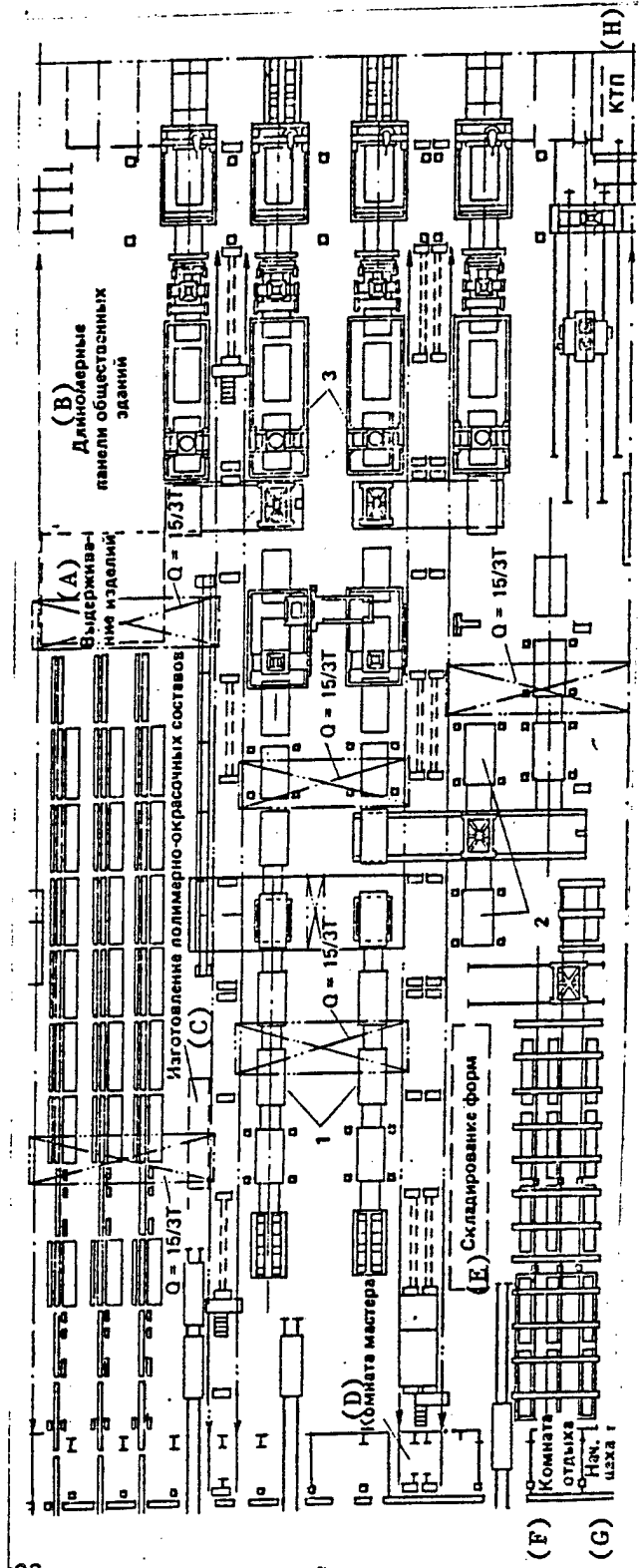

Figure 4.

Key: Production line: Exterior wall panels manufactured in a house-building enterprise in the city of Gorkiy:
 1--Form-striking and form-preparing sections
 2--Form readjustment stations
 3--Mold-pouring sections
 A--Product curing
 B--Lengthy panels for public buildings

C--Polymer-coloring compound manufacture.

D--Foreman's office

E--Form storage

F--Dayroom

G--Shop supervisor

H--Integrated transformer substation

As this enterprise was being planned, use was made of the recommendations and procedures examined here, which insured optimal reserves of capacity and time on the production lines, optimal volumes of replaceable parts in the inventory and an optimal selection of designs for carrying out these or other processes and operations. The plan consists in part of an automated control system which solves a great number of problems dealing with the control of production and output reserves, bookkeeping, deliveries of component sets to the construction site, quality control of output etc. It has been suggested that industrial-type operations and manipulators be used in the enterprise to carry out labor-intensive processes and operations on the production lines and in the auxiliary production sections.

In order to provide the construction build-up with balance and to improve architectural quality, the Gorkiy DSK has plans for a special section to manufacture small lots of architectural components and elements to be used for exterior embellishments. Moreover, part of the enterprise's makeup includes an experimental shop for processing new designs, production procedures and equipment, as well as a corresponding, sufficiently powerful machine shop.

Construction of the Gorkiy DSK has been completed and troubleshooting operations are in progress on the production equipment, and the first sample items have been manufactured. In 1985 this highly mechanized enterprise will begin to produce sets of articles to be used in EZhK construction, and thereafter will also produce items for mass-volume residential housing construction. It is suggested that the Gorkiy DSK experience be used henceforth to introduce improvements into the production base of plant-based house building overall.

CONCLUSION

At the present time solutions have been found to the theoretical and practical problems associated with adequate provision in the production of architectural variety in the new areas being built up with large-panel apartment houses. Flexible manufacturing in residential construction, in solving this important social problem, has emerged from behind the walls of the scientific-planning organizations, and is being introduced to one degree or another into the house-building industry. Both the appearance of our cities and the living conditions of the populace who reside in the newly-developed areas depend on its widespread implementation.

Just what exactly are the problems needing immediate resolution in order for this process to be completed in the shortest possible time?

First of all FLEXIBLE MANUFACTURING IN RESIDENTIAL CONSTRUCTION NEEDS TO BE INTRODUCED ON THE SAME LEVEL AS PLANNING DECISIONS. All the procedural data and accumulated practical experience should become the property of the planning organizations, i.e. those who develop the series of type designs and the plans for house-building enterprises. It is critically important that appropriate procedures be introduced into the process of developing plans for technical re-equipping or renovation of house-building enterprises, inasmuch as the assimilation of new series is being carried out principally on the existing production base with all the variform enterprises which have become elements of that base.

The second task--TO CREATE ECONOMIC MOTIVATION ON THE PART OF THE HOUSE-BUILDING INDUSTRY TO MANUFACTURE A DIVERSE AND VARIABLE LIST OF APARTMENT HOUSES AND RESIDENTIAL BLOCK SECTIONS--is no less important, since otherwise, and with the availability of flexible manufacturing at the enterprises, they will endeavor to produce a limited and stable set of products: this being more simple for them in any case.

It is obvious that the solution to these problems must be put under the control of Gosgrazhdanstroy, subject to USSR Gosstroy and the construction ministries. An operation such as this should be conducted along the lines of goal-oriented integrated programs, with the participation of scientific and planning organizations. The first such programs have been developed, approved and are being implemented within the USSR Minvostokstroy and Glavmosoblstroy Mosoblispolkom system. There is good reason to believe that during the upcoming decade flexible manufacturing in residential construction, as an urgent demand of the times, will become an integral part of our country's house-building industry.

BIBLIOGRAPHY

1. Materials of the 26th CPSU Central Committee Congress.
2. Collection of recommendations and procedures for the planning of new, and the renovation or technical re-equipping of operating large-panel house-building enterprises, with consideration made for starting up production of a varied and variable products list. A collective of authors from TsNIIEP Zhilishcha. Moscow, Izdatelstvo TsNIIEP Zhilishcha, 1982.
3. Kryukov, R. V. "Flexible Manufacturing in Residential Construction", Leningrad, Lenstroyizdat, 1969.

COLUMNAR FOUNDATIONS IN HEAVING SOILS

[Text] It is well known that with regard to low buildings, the most insidious soils are the heaving soils. The water-saturated clays, loams, sandy loams and powdery sands freeze during the winter and increase volumetrically by 5-10 percent. Here, the internal pressure in the heavy heaving soils reaches 5-10 tons/m², and the vertical displacement of their surface layer reaches 10-15 cm. Buckling doorways, terraces and verandas and at times even the walls of houses are, in the majority of cases, the result of the effect of this same freezing heaving action.

When building low buildings on heaving soils, one either has to resign oneself to these forces and place the buildings on so-called floating (shallow-depth) foundations or rest the foundation footing on an immobile base which is located lower than the level to which the soil freezes. In the first case, in order to eliminate the non-uniform soil deformations which happen during their seasonal freezes and thaws they eliminate the solid or lattice-like ferroconcrete foundation which takes up these alternating loads and partially

extinguish them by virtue of its rigid structure. However, this solution requires a relatively extensive outlay of reinforcing steel and concrete, and is approved only when we are dealing with heavy and deeply-freezing heaving and subsiding soils.

In the second case, the foundation footing is set on a non-moving base. This is the traditional, less risky solution, especially when the house walls are made of brick or light blocks and the house has a furnace or fireplace which is sensitive to any soil deformation.

But when setting the footing of a foundation on a non-moving base, i.e. setting it lower than the level to which the soils freeze, one needs to take into account that the forces of the freeze-related heavings do act on the foundation's lateral walls tangentially, and attempt to separate its upper and lower parts. A typical mistake made by many individual builders who construct houses on heaving soils is in their assuredness that the deeper the foundation is laid the better, and that a deep foundation is per se stable and reliable. Of course, if foundations are set lower than the level to which the soils freeze, the freeze-related heaving forces will cease to act on the foundation's footing from below. However, acting on its lateral surfaces they can, in this instance, draw the foundation out of the ground or separate the upper part from the lower and raise it up together with the overlying structures. These cases are most likely when brick or light-weight block foundations are used beneath light-weight buildings.

There are a lot of ways to protect foundations from bulging: by constructing sloping (upwardly tapering) foundation walls; by using vertical reinforcing which connects the foundation's upper and lower parts; by devising, beneath the foundation, a rigid expansion anchor to prevent the foundation from being drawn out of the ground; by covering the foundation walls with a slipping layer (salt or bitumen); by warming the upper layer of the soil (for example, with a layer of keramzit) in order to reduce the freezing depth etc. However, the most radical means by which to eliminate possible deformations in foundations set on heaving soils is by sharply reducing the amount of their surface which comes in contact with shifting soil. And in this regard, columnar foundations have incontestable advantages over continuous footings: on them, this surface is from one-half to one-third (and with tubular supports one-fifth to one-tenth) less than for continuous footings.

In choosing a foundation type, allowance must also be made for the fact that at the depths at which they are laid, strip foundations require extensive outlays of material and labor, and it is for this reason that they have only been approved for use in the construction of basements or cellars beneath houses. However, constructing the latter in heaving soils having a high ground water content is a labor intensive affair and one which is not always approved; even the most thoroughgoing waterproofing often proves incapable of protecting a basement or cellar from moisture. Considering all this, we unequivocally acknowledge that COLUMNAR FOUNDATIONS ARE THE MOST RELIABLE AND ECONOMICAL FOR LOW BUILDINGS BUILT ON HEAVING SOILS. Their design resolutions and the means by which they are produced are fairly varied. Let us consider a few of them, those which are the most economical and available to individual builders (see figures).

(A) СБОРНЫЕ СТОЛБЧАТЫЕ ФУНДАМЕНТЫ

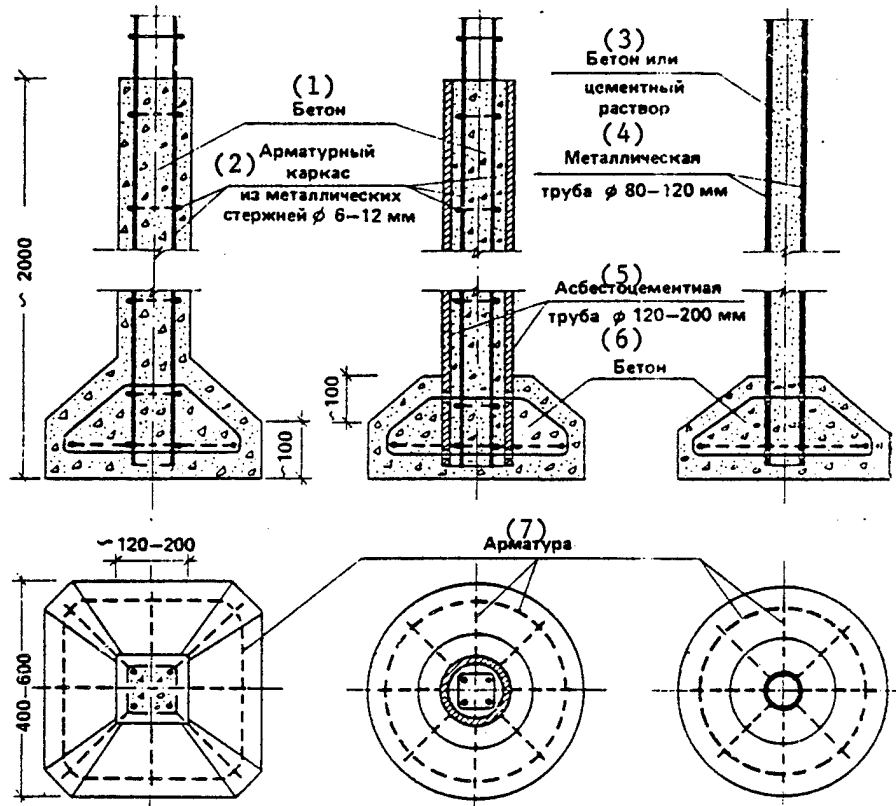

FIGURE A: PRECAST COLUMNAR FOUNDATIONS

Key: 1--Concrete

2--Reinforcing rod framework

3--Concrete or cement slurry

4--Metallic tube, 80-120 mm in diameter

5--Asbestos-cement pipe, 120-200 mm in diameter

6--Concrete

7--Framework

PRECAST FOUNDATIONS. These are especially suitable for working in swampy areas (where the construction of cast in-situ concrete foundations is hampered or generally impossible due to high ground water levels), as well as for working within compressed construction deadlines.

The ideal shape for precast foundations is a bearing column having the smallest possible cross section, which is rigidly connected to the baseplate. The articulated joint of the bearing column to the baseplate (i.e. their being separately manufactured and subsequently assembled during installation) is regrettable in that it lessens the foundations' lateral stability, and where there is no rigid poured in-situ ferroconcrete foundation mat, can lead to their lateral displacement. Unfortunately, the industry does not manufacture this type of foundation, so they have to be "home made" by the individual builders. The bearing column can be made of reinforced concrete or asbestos-cement pipes reinforced internally and filled with concrete, as well as of metallic pipe filled from within with a concrete or cement slurry, and protected on the outside with a bitumen mastic or an epoxy resin.

Ferroconcrete columns have a cross section of about 120 X 120 to 200 X 200 mm at a height of about two meters (depending on the reinforcing method used and the grade of the concrete). Metal rods of 6-12 mm's diameter may be used for the framework, as can scrap metal from old gasoline pipes, angle iron etc. It is best to make the concrete from high-strength (300-400 grade) cement, and for aggregate, use clean coarse sand and crushed gravel (fine sand with clay particles, and limestone or brick-scrap gravel will lower the grade of the concrete even when high-grade cement is used). The concrete should be mixed in these proportions: 1 part cement, 3 parts sand, 3-4 parts gravel; add enough water to maintain plasticity in the concrete: it should be able to be poured into the form (but not soupy!) with a little tamping. Remember that the stiffer the concrete, the stronger.

Ferroconcrete columns with rectangular cross-sections are manufactured on an area of level ground, in a "lying down" position. Boards set on edge with the distance between them equal to the thickness of the columns being manufactured are used as concrete-pouring forms. Prepared roofing paper is nailed to the boards from below, thus keeping them from moving during the concreting process. Battens are nailed crosswise on top for the same purpose. In order to keep the boards from bonding to the concrete, their surfaces are covered with asphalt roofing paper or plain paper. Before the concrete is poured, the connected-up metal framework is laid into the form onto the ceramic or asbestos-cement liner. From the two sides (faces) of each column, the framework should extend beyond the ends of the form so that: the baseplate can be attached on one end, and so the cast in-situ ferroconcrete foundation mat can be attached on the other. The size of the metal framework should be 20-30 mm less on either side than that of the end product. In order to keep the surface of the poured concrete from drying prematurely, wet rags or newspapers are laid on top and covered with asphalt roofing paper. After a week in temperatures of 10-15° C the concrete columns are strong enough to be taken from the forms and readied for manufacture of the baseplate.

The plan generally calls for the baseplate to be three times the width of the bearing column (if the cross-section of the column is 150 X 150 mm, then the cross section of the baseplate comes to 450 X 450 mm). At an allowable soil pressure of 1.5-2 kg/cm² (which is the average index for heaving soils) with a 500 X 500 mm baseplate, the bearing capacity of the foundation column will be 3.5-5 tons.

Prior to concreting the baseplate, an additional framework is attached to the free length of the lower framework reinforcement bars. Mesh forms the same size of the future baseplate are made at the same ground area (the same boards, or plywood trim, orgalit or cardboard can be used to build them). The previously prepared columns are set up vertically in them and the base part of the foundation is concreted using the same production method.

The foundation pits are dug either manually (by using a garden auger as a "leader", as well as to lift out the earth, or by a mechanical (vehicle-mounted) drill. It is desirable to widen the pit bottom by 50-100 mm all around, and to put a 50-100 mm-thick layer of carefully tamped crushed rock on the bottom. This can increase the foundation's bearing capacity by as much as 20-30 percent. Two persons can place the foundation column into working position. An average-sized column and baseplate will weigh no more than 100 kg.

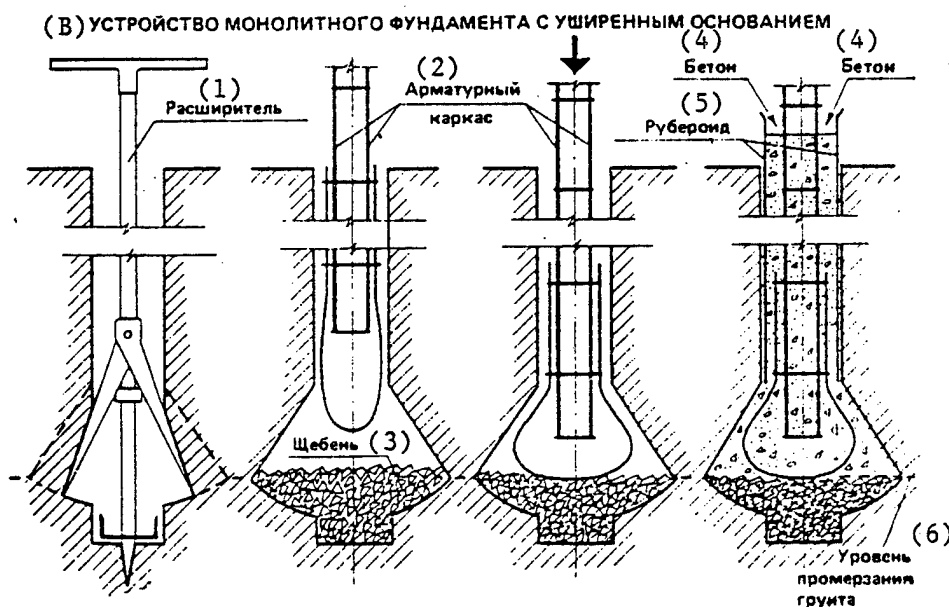

FIGURE B: CONSTRUCTION OF POURED IN-SITU FOUNDATION WITH EXPANDED BASE
 Key: 1--Expander; 2--Metal framework; 3--Crushed rock; 4--Concrete;
 5--Prepared roofing paper; 6--Level to which soil freezes

POURED IN-SITU FOUNDATIONS. In locations where the ground water levels are lower than the foundations' bases, poured in-situ ferroconcrete can be used successfully. Here we present the most effective method for constructing these foundations (successive stages shown in the figure). A pit is dug out to the depth to which the ground freezes with a 150-200 mm gardening auger. We use special attachments to dig a partial expansion 300-400 mm wide at the bottom of the pit. On the bottom, to the level where the diameter is greatest, we put a layer of gravel and tamp it. Then we lower the metal framework into the hole. On its bottom, this framework has free loops which, when the framework is at rest on the crushed rock fill, and the fan-shaped attachment is pressed onto it from above, spread to the sides. Then we thrust the coiled prepared roofing paper into the upper (narrow) neck of the pit, and fill the pit with concrete. This is how we make a cast in-situ ferroconcrete column which is rigidly connected to the baseplate anchor.

The entirety of the complexity (and originality) of this method lies in **WIDENING THE LOWER SECTION OF THE PIT AND IN FABRICATING A METAL FRAMEWORK WHICH SPREADS TO THE PIT'S SIDES WHEN COMPRESSED.** Manufacturing the upper part (the bearing column) of the foundation in advance will speed up construction of this foundation. Here, we will lower a ferroconcrete column with its metal framework extending from the bottom into the pit, which has previously been filled with cement slurry, and then set it into operating position.

If digging pits which are widened at the bottom and manufacturing an expanding metal framework seems complicated to you, then cast in-situ or precast poured in-situ columnar foundations can be manufactured by the traditional method, i.e. by digging the pits to a width equal to the cross-section of the base plate. In this case, the only thing that increases is the volume of earth-moving work, and the foundation design resolution itself remains unchanged.

In conclusion, let us once again recall that when constructing columnar foundations in heaving soils **THE "ANCHOR"--the baseplate which is rigidly connected to the bearing column--MUST BE PART OF THE CONSTRUCTION.**

In the presence of horizontally moving soils (on slopes) an upper binding (foundation mat) is necessary to make the columns into a united rigid structure, preventing their leaning or tipping over.

TABLE OF Contents

Introduction.....	3
The Producibility of Sets of Building Products and Flexible Manufacturing in Residential Construction.....	8
Procedures for Renovating House-Building Enterprises, Taking Flexible Manufacturing Methods Into Account.....	15
Assimilation of Flexible Manufacturing in Fully-Prefabricated House-Building Enterprises.....	32

Conclusion.....39

Appendix "Let's Build It Ourselves", by V. M. Masyutin, architect.
"Columnar Foundations in Heaving Soils".....41

COPYRIGHT: Izdatel'stvo "Znaniye", 1985

12659

CSO: 1821/133

CONSTRUCTION MACHINERY AND EQUIPMENT

DATA ON CONSTRUCTION WORK, EQUIPMENT UTILIZATION

Moscow MEKHANIZATSIYA STROITEL'STVA in Russian No 2, Feb 85 pp 2-4

[Article by P. I. Moiseyev, construction automation and mechanization department chief, USSR Gosstroy, under the rubric "27th CPSU Congress -- A Worthy Greeting": "Prerequisites for and Base of Progress in Construction Mechanization"]

[Text] The [success of the] year of preparing for the 27th Congress of the Communist Party of the Soviet Union and retooling practically all branches of the national economy depend largely on successful implementation of capital construction which, as was noted by Comrade K. U. Chernenko, CPSU Central Committee General Secretary and Chairman of the USSR Supreme Soviet Presidium, is one of the pivotal problems. In this area, we have planned high rates of growth, a greater concentration of resources and the best possible supplies of materials and machinery, which will create prerequisites for builders to be able to put an end to rush work, to improve quality and to finally begin coping with plan assignments.

During the 10th and 11th five-year plans, the number of machines designated for all types of construction work has been increased, including mastering the production of machines for comprehensively mechanizing construction-finishing work. The quantitative growth in the stock has been accompanied by qualitative changes as well. New types and type-sizes of machines have appeared: we have mastered the series production of hydraulic excavators and cranes, wheeled single-scoop loaders; the products list of finishing machines has been expanded, and we have mastered the production of new types of mechanized and hand tools.

The 1985 plan anticipates a significant increase in deliveries of excavators, bulldozers, graders and cranes to contractor construction ministries. This will create conditions favorable to accelerated updating of the fleet of machinery, the necessity for which is obvious.

The availability of machinery to construction does not, in the main, correspond to contemporary construction production demands, to improving work methods. The Minstroydormash [Ministry of Construction, Road, and Municipal Machinebuilding] continues to produce primarily small machines, excavators with scoop capacities under 0.5 m³, class 3-tf bulldozers, scrapers with scoop capacities of 3 m³, 6.3-ton cranes and other machinery which cannot ensure improvement in

technology or a substantial lowering of labor expenditures, complicating work organization and raising costs. At the same time, large machines with greater scoop capacities and load capacities are being produced in entirely inadequate quantities: there is very limited production of excavators with scoop capacities of 1.6 - 2.5 m³, of 10-15 tf bulldozers, of 4- and 6-ton single-scoop loaders, of 25- and 63-ton hydraulic cranes with telescoping booms, and of machines for driving piles and for "wall-in-ground" installation.

The hydraulic excavators being produced are not provided with the needed mounted equipment, such as clamshells, hydraulic hammers, rams, replaceable scoops and grippers of various designs, equipment for drilling holes in the ground, and so on, as a result of which their technical potential is not being fully reached.

In order to do the work efficiently and reduce labor expenditures, we need to series-produce not individual machines, but whole series of machines which will, in the aggregate, ensure comprehensive mechanization and automation of the technological process as a whole. The Ministry of Construction is not yet ensuring this. Thus, there are insufficient devices for automatic mixing in winter, automatic cement mixers and cement pumps for transporting concrete mixes at low temperatures, and vibro-vacuum concrete laying equipment, not yet in industrial production, to comprehensively mechanize work with monolithic concrete.

The quality and reliability of the concrete pumps in this complex are poor, not allowing stability in the technological process at the construction site. All this has a negative impact on the effectiveness with which progressive construction technology is applied.

Technologies involving few operations and energy-saving technologies have not received proper development in construction production due to the lack of a full complex of machines for such work. Use of the "wall-in-ground" method and the installation of drilled-driven piles to protect concrete-block slurry are not fully backed up with installations to manufacture and recycle this slurry, with machines to anchor the construction components, and so on.

The cheapest and least energy-intensive construction scraping method is used in only 8-9 percent of all earthmoving work, as against the 35-40 percent in several countries abroad. The reason is that domestic industry produced small scrapers with scoop capacities of 3-4 m³. Over the last 10 years, the Ministry of Construction has been producing 60-70 units per year of the largest self-propelled scrapers, ones with a 15-m³ scoop, and the ministry produced in 1984 a total of only three of the 25-m³ scoop-capacity scrapers it has been working on for more than 15 years. Given this volume of production of progressive equipment, it is hard to achieve fundamental changes in the efficiency of construction production.

The working of frozen ground is a pressing problem, especially in connection with increasing the proportion of construction in eastern and northern parts of the country. Due to the lack of sufficient or any such machines, frozen ground at construction sites must be worked by inefficient, expensive, low-productivity methods.

BAM and gas main construction experience, in which rippers on large tractors are used to work frozen, permafrost and rocky ground, confirms the high efficiency of this equipment. However, The Cheboksary plant's production of domestic industrial tractors designed as base models for powerful bulldozers, rippers and pipe-layers is being mastered impermissibly slowly.

Due to their extremely limited production, wheeled 4- to 6-ton and larger loaders with various types of replaceable equipment, which can perform both loading-unloading operations and freight and materials transport within the working zone, are still not being widely used in earth-moving, quarrying and loading-unloading work. Minstroydormash enterprises manufacture loaders of up to three tons, but do not series-produce larger loaders.

Minstroydormash tower crane production does not meet the requirements for installing consolidated components and unitized installation technology, which have received broad recognition, either in terms of quantity or in terms of load capacity.

Given an overall tower crane production level of 2,200 to 2,300 per year, only 20 are those of new and improved designs, the 10-ton tower cranes needed to install housing, and the demand is for 500-700 units. As a result, the number of machines with an expired service life is increasing in construction organization fleets and the average power of basic machinery in contractor construction is growing slowly. Increasing construction work volumes will therefore require a proportional increase in the number of machines and workers employed in servicing them.

The effectiveness with which construction and roadbuilding machinery is used has dropped significantly due to their inadequate reliability and suitability for technical service and repair, one consequence of which is significant labor expenditures and losses of working time in the course of operating them. On average, construction organizations spend 0.3 to 0.8 man-hour on technical service and repair for each hour of machinery working time.

Perfecting and further developing the production of implements of construction labor must ensure qualitative changes in construction production, increased construction effectiveness and a reduction in project construction time. The Minaftoprom [Ministry of Automotive Industry], Minstroydormash, Minsel'khoz mash [Ministry of Tractor and Agricultural Machinebuilding] and other machinebuilding ministries connected with manufacturing construction machinery are obligated to meet in full construction organization's requirements for effective new equipment and, in so doing, to ensure accelerated scientific-technical progress in the national economy.

A second key direction in increasing labor productivity and improving production effectiveness in construction is the continued development of mechanization, perfecting work organization and technology, and improving the use of equipment available to construction workers.

The 1985 plan for comprehensively mechanizing and automating construction and installation work, which has been approved by the USSR Gosstroy, focuses the attention of the construction ministries and departments on just these tasks.

Plan assignments must be met by improving construction production management organization, increasing the effectiveness of engineering preparation and bringing proper order to construction sites.

The union republic construction ministries, departments and organizations are doing work aimed specifically at raising the level of construction-installation work mechanization, at improving the organization of repairs and technical servicing of construction machinery and motor transport, which resulted in the following reductions in absolute amounts of work done by hand in the first half of 1984 as compared with the corresponding period the previous year: loading and unloading -- by 2.4 million tons, plastering -- by 1.9 million square meters, roofing -- by 1.7 million square meters. During the indicated period, scraper output rose by 1.4 percent and bulldozer output rose by 0.8 percent. The annual productivity per concrete pump increased by 8.3 percent.

At the same time, several construction organizations have permitted a reduction in individual work indicators achieved as compared with the preceding period. Thus, an increase in earthmoving work was permitted by the USSR Mintyazhstroy [Ministry of Heavy and Transport Machinebuilding] and USSR Minsel'stroy [Ministry of Rural Construction] in the first half of 1984 as compared with the first half of 1983; the USSR Minpromstroy [Ministry of Industrial Construction], USSR Minstroy [Ministry of Construction] and Minvostokstroy [Ministry of Construction in the Far East and Transbaykal Regions] permitted an increase in manual concrete work, and organizations of the USSR Minvodkhoz [Ministry of Land Reclamation and Water Resources] and USSR Minmontazhspetsstroy [Ministry of Installation and Special Construction Work] permitted an increase in manual loading-unloading work. The USSR Minstroy and USSR Minenergo [Ministry of Power and Electrification] permitted a drop in scraper and tower crane output, and output by excavators and tower cranes dropped in the USSR Mintyazhstroy, USSR Minpromstroy and Mintransstroy [Ministry of Transport Construction].

Data from normative-research stations and sample checks on equipment use at construction sites show that there has been a reduction in machinery intrashift idle time in recent years, but that it is still very high: 16.6 percent at construction sites of the USSR Minenergo, 15.5 percent in the USSR Minsel'stroy and 14.4 percent in the USSR Minstroy -- shift time the machinery is not operated.

As the report data show, machinery operation does not exceed 10-12 hours out of every 24.

Higher-power and more-productive machinery is still being used inadequately in the ministries (Table 1, following page).

It should be noted that the presence in the fleet of machinery of large numbers of machines beyond their service lives, in a proportion of 12-23 percent, and the extremely unsatisfactory supply of spare parts (38-45 percent of demand) and imbalance in the fleet structure for individual types of equipment have a negative influence on the level of machinery use.

The 1985 plan for comprehensively mechanizing and automating construction-installation work anticipated continued development of the mechanization of labor-intensive construction processes and ensuring that the growing amounts

Table 1.

Machinery Operation Per Day, Hours

Министерства	(1) Экскаваторы		(2) Бульдозеры		(3) Краны башенные	
	(7) всего	(8) в том числе вместимостью ковша 0,65 м ³ и более	(7) всего	(9) в том числе с тягой 6 тс и более	(7) всего	(10) в том числе грузоподъемностью 10 т и более
(4) Минтяжстрой СССР	11,5	11,8	11,5	12,2	12,9	13,7
(5) Минпромстрой-СССР	10,3	10,8	10,3	11	13,1	13,4
(6) Минстрой СССР	10,9	11,3	10,8	11,7	12,8	13,8

Key:

- | | |
|------------------|---|
| 1. Excavators | 7. Total |
| 2. Bulldozers | 8. Including scoop capacities $\geq 0.65 \text{ m}^3$ |
| 3. Tower Cranes | 9. Including $\geq 6 \text{ tf}$ |
| 4. Mintyazhstroy | 10. Including load capacities $\geq 10 \text{ tons}$ |
| 5. Minpromstroy | |
| 6. Minstroy | |

of construction-installation work will be done, improved use of the fleet of construction machinery and trucks, development of automation, improved machinery repair and higher repair quality. Assignments on reducing the amounts of work done by hand have been set somewhat higher for loading-unloading, concrete work, plastering, painting and roofing that was outlined in the five-year plan. Certain prerequisites for this have been created: the availability of finishing machines and tools has been improved, construction site tool supply has been strengthened.

The provision of construction organizations with small-scale mechanization, including equipment manufactured at industrial enterprises of the construction ministries and departments, has proceeded at faster rates. The number of painting and plastering stations has been increased by 18 percent, the number of portable tool-distributing stations -- by 29.5 percent, and mechanized tools -- 9.4 percent.

Builders have better supplies of hydraulic-drive machines, machine complexes for installing roll roofing, new types of plastering and painting stations, jackhammers, drill-crane machines and other equipment for mechanizing labor-intensive processes.

The level of mechanization of roofing work is to be increased to 67 percent in 1985, as against 49.8 percent in 1980, on average for the group of organizations being planned for, with a nine-point increase in the five-year plan assignment.

Machinery output is to increase as follows in 1985 as compared with 1980: excavators -- 6.5 percent, scrapers -- 7.1 percent, bulldozers -- 14.3 percent, caterpillar and wheeled cranes -- 15 percent, and tower cranes -- 11 percent.

The anticipated growth in physical work levels in 1985 as compared with actual work volumes in 1980 (Table 2, following page), especially for earthmoving and

loading-unloading work, is connected with an increase in the overall levels of contractor work in construction (by 13.5 percent for the group being planned for as against 1980), as well as with the significant growth in water-management construction associated with environmental protection and with growth in construction in regions of difficult access.

Table 2. Construction Work Levels

	1980 (report)	1985 (draft plan)	growth rate, 1985 in percent of 1980
earthmoving, million m ³	13,027.4	15,701.4	120.5
loading-unloading, million t	1,653.1	1,980.3	119.8
concrete and reinforced concrete, million m ³	74.65	78.72	105.5
installation of construction components, million tons	308.8	338.4	109.6
plastering, million m ²	353.9	386.7	109.3
painting, million m ²	891.3	962.4	107.9

In connection with the fact that the Minstroydormash has failed to ensure development of the production of complete sets of automatic batch-type cement mixers during the 11th Five-Year Plan, we have not succeeded in ensuring reaching the level of concrete preparation automation outlined for the five-year plan.

In 1985, we intend to switch 428 stationary and 470 stock cement-slurry centers, shops and installations over to automatic operation. The planned level of cement mixture preparation automation is to be 57.3 percent in 1985, and the level of slurry preparation automation is to be 47.9 percent.

It should be noted that construction organizations have been insufficiently active in changing existing cement-mixing installations over to automated control. They are not ordering the necessary equipment promptly and are not paying for it on time, which leads to unfulfilled delivery agreements. Personnel training to service this equipment is organized unsatisfactorily.

Each year, more than 18,000 excavators, 51,000 tractors and machines based on them and 8,900 cranes are overhauled, costing 700 million rubles. One obvious reserve for improving use of the fleet of construction machinery is to reduce idle time spent in repairs and waiting for repairs and to improve the quality of repairs and technical servicing.

The 1985 plan anticipates construction ministry and department assignments based on level of centralized (factory) major overhaul of basic construction machinery (see Table 3, following page).

As is evident from Table 3, 1985 plan assignments for basic construction machinery are 2-3 percent higher than the 1983 reporting data and are close or equal to the control figures for the five-year plan.

Table 3. Ratio of Major Overhauls Done Centrally to Total Number of Overhauls

	1983	1985	
	(report)	five-year plan	1985 draft plan
single-scoop excavators	69	76.5	75
bulldozers	71	75.5	75.1
crane trucks	68	71.5	70.6
grader trucks	73	75	75
wheeled cranes	64	--	69.1

Slight underfulfillment of the five-year plan assignments has been caused by very unsatisfactory coverage of the spare parts requirements of repair plants -- 35-40 percent, as well as by the absence of centralized planning of the major-overhaul load on repair plants on an interdepartmental basis, including allocation of the necessary material-technical resources.

With a view towards raising the technical level of repair production and improving machinery repair quality, the plan outlines ministry and department assignments on introducing a "Comprehensive System of Product Quality Control" (KS UKP RP) at 62 repair enterprises, which will enable us to raise the level of system introduction to 67 percent of the total number of repair enterprises in construction by the end of the 11th Five-Year Plan.

The 1985 plan outlines assignments on developing progressive methods of organizing shipments by motor vehicle, perfecting rolling stock TO [technical servicing] technology and creating standard designs for specialized means of motor transport in the construction ministries.

The planned 1985 increment in construction freight shipments as compared with the levels expected in 1984 is 3.6 percent, and the planned freight turnover increment is four percent. About 1.9 billion tons of construction freight (excluding earth), or 34.6 percent of all shipments, will be made centrally, which is five percent higher than the level achieved in 1983. A 111.7 million-ton increase is anticipated in trailer-truck shipments.

With a view towards improving labor productivity and reducing manual operations and losses in loading and unloading, we anticipate an increase in containerized and packetized shipments to 140 million tons, 60 percent more than in 1983. The percentage of brick and other small wall materials being delivered in packets and on pallets will be 74.7 percent.

Shipments in which the brigade contract is used will increase from 1,514 to 1,780 million tons, which is 32.7 percent of the total shipment volume (as against 27.6 percent in 1983), including an increase of from 953 to 1,111 million tons, or 15.5 percent, in working and transporting earth using multipurpose contract brigades, and an increase from 118 to 186 million tons, or 57.9 percent, for shipments of concrete and slurry following hourly schedules.

As compared with 1983, motor vehicle productivity must be increased by 5.8 percent (in tons per scheduled vehicle-ton).

In order to raise the technical level of truck service and repair, the draft plan anticipated the start-up of 74 lines and posts for mechanized full service, 79 diagnostic centers, and mechanized truck washes which recycle the water, to handle 15,200 vehicles. Moreover, we intend to manufacture more than 6,500 units of specialized motor transport equipment for hauling construction freight at construction ministry and department vehicle repair plants.

The plan also outlines other assignments aimed at further developing the mechanization and automation of construction work, introducing new materials and progressive methods of mechanization into construction, expanding the network of small-scale mechanization sectors and administrations and improving their use, all of which will ensure a substantial lowering of labor expenditures in construction in comparison with the level expected for 1984.

COPYRIGHT: Stroyizdat, 1985

11052

CSO: 1821/136

UDC 69.003:658.011.8

ARGUMENTS FOR REPLACEMENT OF OBSOLETE CONSTRUCTION EQUIPMENT

Moscow MEKHANIZATSIYA STROITEL'STVA in Russian No 4, Apr 85 pp 6-8

[Article by E. A. Dolginin, director of TsNIIOMTP [Central Scientific Research Institute for the Organization, Mechanization and Technical Assistance of Construction], candidate of technical sciences and Hero of Socialist Labor: "Scientific and Technical Progress and the Mechanical Outfitting of Construction. For Accelerating Scientific and Technical Progress."]

[Text] Under modern conditions when scientific and technical progress (NTP) is becoming the chief factor for economic and social development in all spheres of the national economy in our country, the further development of science and accelerating the adoption of its achievements in production are acquiring special importance.

In light of the CPSU Central Committee and USSR Council of Ministers' decree "Concerning Measures to Accelerate Scientific and Technical Progress in the National Economy" turning out products that are on a par with the best modern examples, the adoption of advanced technological processes, strengthening all links that are associated with the creation and adoption of new technology, and significantly improving labor productivity based on this are the chief goals of all enterprises and organizations in the construction complex.

The industrialization of capital construction in the post-war period was accompanied by an increase in the value of fixed production assets (by a factor of 67 from 1945 through 1980) and significant changes in the mechanical outfitting of construction.

The fleet of construction machinery in the sector numbers more than 660,000 units of basic machines alone and the value of it (excluding motor vehicle transport) is approaching 20 billion rubles.

The average annual rate of increase in the fleet of construction machines per 1 million rubles of construction and installation work (SMR) in a value expression amounts to about 4.8 percent over the last 10 years while the rates of increase for the mechanical outfitting of a single worker with basic machines amounts to 8.3 percent. The production of modern highly-productive technology such as hydraulic excavators, for example, is increasing; the production of cranes on a special chassis with a load-lifting capacity of 25

and 40 tons has been organized; modern highly-productive finishing machines, mechanized tools and others are being manufactured in serial production.

The industrialization of construction and the growth in the mechanical outfitting of labor has made it possible to substantially increase its productivity. Thus, the total labor productivity for SMR workers grew by a factor of 4.82 by 1981 in comparison with 1950, and real conditions were created to substantially reduce the duration of building projects.

However, the building up of a material and technical base for construction is not the sole method for industrializing it. The renovation and improvement in the use of the existing base is of no less, and possibly of greater, importance.

This fully pertains to the mechanical outfitting of construction--one of the primary factors of industrialization. Thus, with high rates of growth for the mechanical outfitting of labor in construction the rates of growth of labor productivity that are dependent on this factor are substantially lower (over the past 10 years it was 11.8 percent and 4.8 percent respectively in earth work and 13 percent and 3.1 percent in installation and loading and unloading work). This once again is proof that at the present time the problem of not a quantitative growth in the fleet of machines but rather an improvement in the qualitative characteristics of the technology that is being turned out and the degree to which it is used is especially urgent.

It is known that one of the primary indicators of NTP is the growth in the fleet of technology that is being used and the time needed to replace it. Meanwhile, based on data from TsNIIOMTP, machines with a length of service of five years or more comprise the core of the operating fleet of excavators and almost 20 percent of them are being used beyond their expected length of service. There is a similar situation with the bulldozer, scraper and crane fleets. It is clear that a substantial "rejuvenation" of the members in these fleets is required.

Calculations show that removing morally and physically outmoded technology and replacing it with new technology from the numbers that are turned out serially can free no less than 150,000 workers as a result of reducing the number of operating and repair personnel and improving labor productivity when doing mechanized work which is equivalent to improving labor productivity in construction by 2.7 percent.

Under these conditions the role of accelerating the development of new technology and organizing its serial production is quite obvious. At the same time, the actual situation that has developed here requires a quick and fundamental change.

It is impossible to accept as satisfactory the fact that the actual length of time for replacing products that are turned out by the Ministry of Construction, Road and Municipal Machine Building approaches 15 to 20 years for the primary groups of construction machines. In our opinion the distinctive qualities for new and modernized technology have not been

sufficiently clearly defined in the existing standards, for example, in one of the basic sector standards for the Ministry of Construction, Road and Municipal Machine Building, OST 22-9-74 "The System of Developing and Preparing Products for Production. The Products of Construction Road and Municipal Machine Building," which was worked out for the basis of and in developing GOST 15.001-73. In addition, in accordance with these standards, coordinating the technical goals for modernizing machines with the consumers is not mandatory. As a result, a new or repeatedly modernized machine does not have noticeable advantages although the wholesale factory price of it, as a rule, increases significantly.

The development and approval of progressive, economically sound and differentiated standards for replacement times (modernization) of construction technology and also making the basic standards consistent with them is a condition that is fully required for accelerating NTP.

It is known that the technical and economic indicators for the mechanization of construction production directly depend on the degree to which the fleets of machines that exist in construction organizations are at an optimum level, i.e. on their applicability to the planned complex of work based on optimum technology. Therefore, TsNIIOMTP is working out the optimum technological make up and structure for a fleet of construction machines based on extensive technological studies of each planned five-year period and the outlook for the next 20 years. The primary indicators for the production of construction and road machines for the planned period is being determined jointly with the Ministry of Construction, Road and Municipal Machine Building: the products list for the technology that is being turned out, a list of the machines that have been newly developed and that are to go into serial production, and machines that are to be replaced.

The conclusive document "The System of Construction and Road Machines," which was approved jointly by the Ministry of Construction, Road and Municipal Machine Building and USSR Gosstroy (as the representative for the consumer) has great estimated potential. Thus, "The System of Construction and Road Machines for 1981-1985" estimates that about 500,000 people will be conditionally freed from doing SMR during the 11th Five-Year Plan. However, it can already be said that in reality this figure will hardly exceed 100,000 to 120,000 people. The reason is the significant delay in developing the production of new technology and the prolonged output of outmoded machines.

In order to correct the situation it is necessary to first of all increase the role of the system of machines in determining not only the products list (as it does now) but also the number and timeframes for developing new technology, producing it, and removing outmoded machines from production. Certainly all of the figures for the system must be coordinated with USSR Gosplan and the basis of the plan for the Ministry of Construction, Road and Municipal Machine Building must be drawn up for the given group of machines.

An analysis of the technical level of the construction machines that are being turned out by the Ministry of Construction, Road and Municipal Machine Building, which was systematically done by TsNIIOMTP, shows that the

indicators of reliability, durability, comfort of working conditions, the number and products list of the interchangeable working parts and working equipment requires the greatest attention and unconditional improvement. Earth-moving, earth-moving and transporting, and load-lifting machines with greater individual power, general purpose mini-technology for producing work under crowded conditions, modern caterpillar tractor type excavators in the third and fourth size groups, truck cranes on a special chassis with a load-lifting capacity of 40, 63 and 100 tons, cranes with a short base having a load-lifting capacity of 16, 25 and 40 tons, truck cranes with telescoping booms, excavators and cranes for use in the North and others are being turned out in intolerably small amounts.

The primary reason for this is not due as much to the lack of developing the necessary machines (although this occurs chiefly where base machines and engines are lacking) as it is due to the excessively drawn-out process of starting up the serial production of new machines. For example, the technical requirements for short-base cranes having a load-lifting capacity of 10 and 16 tons had already been worked out in 1979 and the technical design for a crane with a load-lifting capacity of 16 tons in 1981; however, their serial output has still not been started up to now and the same situation exists with the self-propelled scraper with a bucket capacity of 25 cubic meters, experimental models of which had already been made at the Chelyabinsk Road Machine Plant imeni Kolyushchenko in 1975-1976.

In 1979 documentation was worked out by TsNIIOMTP for a complete set of equipment for suctioning concrete mixtures; the Minsk branch of VNIISMI [not further identified] together with TsNIIOMTP prepared the documentation to assign it to a plant; however, serial production was not begun and the technology is becoming outdated in the meantime.

Many such examples can be given. Along with this more than 40 types of outmoded machines continue to be produced while their output was specified to be discontinued by the approved System for Machines for the 11th Five-Year Plan. Resources are being spent on them and production capacities are not being utilized. All of this once again confirms the necessity of increasing the role of the system for machines to the level of a planning and reporting document that must be followed.

In construction and road machine building, NTP is accompanied by an increase in the complexity of construction technology and its saturation with means of automation, microprocessors, high-pressure hydraulic systems, high-precision devices and others. This even more urgently puts the question on the agenda concerning a change in the system of organizing the technical maintenance and repair of construction machines which has been formed where the plant manufacturer has practically no obligation to maintain the machines in an operating state during the process of its use. It is obvious that there is a need for the organizations in the Ministry of Construction, Road and Municipal Machine Building to convert to maintenance and repair service without delay.

Along with organizing maintenance and repair service organizations in the Ministry of Construction, Road and Municipal Machine Building must set up

specialization in repair work on construction machines for the more complex assembly units based on inter-departmental (inter-ministry) cooperation in a territorial section and must also implement the gradual conversion to turning out machines that do not require capital repairs during the course of the entire established period of service.

These are the key approaches today for improving the technical use of the fleet of construction machines.

It is known that a significant portion of the machines and equipment that are used in construction are turned out by construction ministry forces; they manufacture a large portion of the load-grabbing devices, packaging, stock shoring, scaffolding and other mechanized means. The technical level of many of them are on a par with the best similar products. This refers most of all to special machines and tools such as assembly cranes by the USSR Ministry of Installation and Special Construction Work and the USSR Ministry of Power and Electrification, truck concrete pumps by the USSR Ministry of Construction of Heavy Industry Enterprises, an installation tool by the USSR Ministry of Installation and Special Construction and others.

At the same time various construction ministries and departments are making and extensively using mechanized means and equipment (this especially refers to small mechanized means) that were developed by them which are similar in their purpose and technical parameters but are significantly different in their consumer features. It is readily evident that the technical level of the majority of them is far from that which is required.

Further growth in this sphere of activity of construction ministries is possible, however, with a mandatory limit by the Ministry of Construction, Road and Municipal Machine Building on the technology being turned out (for example, manufacturing specialized technology, a certain group of small machines and equipment with construction ministry forces), centralized planning and allocating material and technical resources and concentrating developmental work and manufacturing technology in enterprises and organizations that are specially appointed and equipped for this. It is also necessary to tighten control over the technical level of the products being turned out.

With the aim of conducting a more effective uniform technical policy on this question the "Unified List of Small Mechanized Means in Construction" was worked out and is periodically updated (every two years) by TsNIIOMTP with the participation of the primary construction ministries which contains about 500 small mechanized items that are recommended for use for all types of general construction work. On the Institute's initiative a special interdepartmental commission for coordinating developments in small mechanized means which are implemented by various ministries has also been formed and is in operation whose task it is to review and coordinate technical requirements and technical assignments for new models and to work out recommendations to further realize them. However, these measures, which do not yet have legal force, are not sufficient. A more centralized effective control over the technical level of the products being turned out by the ministries is needed.

The problems in providing construction with tools and, in particular, mechanized tools are of a specific nature. The total number of mechanized tools and construction finishing machines that are being used exceeds 1,500,000 units and continues to grow. The Ministry of Construction, Road and Municipal Machine Building turns out 95 percent of the tools for SMR. At the same time research that was done by TsNIIOMTP shows that demand by construction workers for tools is substantially higher (by a factor of 3.5 to 4). Thus, in accordance with the norms of the need for mechanized and hand tools and finishing machines which were worked out by TsNIIOMTP on the basis of using mass advanced technological processes, the average level at which one worker who is engaged in SMR is equipped should amount to 0.45 units; the actual level at which he is equipped based on the status as of 1 Jan 1984 did not exceed 0.12 units.

The structure for the production of mechanized tools also does not meet the demands of construction in its conformity to technological processes and operations and in the regularity with which tools and auxiliary complementary equipment that make it possible for them to operate are turned out.

For example, in accordance with SNiP [State Standards and Specifications] the more massive types of plaster work encompass 12 to 14 technological operations (preparing the surface, setting the towers, spraying, smoothing etc.) and only 4 of them are done by a mechanized tool. There is a similar situation with paint and other work.

Mechanized tools are not being manufactured for applying fire and heat protection, insulation, waterproofing, cleaning facades, removing old finish coverings during reconstruction and other types of work.

Due to a lack of current frequency converters quite a few plastering and smoothing machines are not in operation, depth vibrators are not sufficiently provided with bendable shafts, and there are not enough interchangeable parts (drills, cutters, diamond tools, saw blades and others).

The modern highly-productive 2600N and 7000N painting units that are being turned out by the Vilnius SOM [construction finishing machines] Plant are standing idle due to the fact that the nozzles that were delivered with the units having diameters of 0.45 and 0.53 mm were not made with consideration for the particle size of the paint that is being produced by the Ministry of the Chemical Industry and the republic ministries of local industries and there are no nozzles with a diameter of 0.8 or 0.9 mm.

Nor is everything satisfactory with the distribution of mechanized tools. For example, during 1981 to 1984 the Heavy Machine Building Production Main Administration in USSR Gosstab allocated less than a fourth of all the tools being produced by the Ministry of Construction, Road and Municipal Machine Building to ministries that are doing the greatest amount of SMR--much less than needed.

In view of what has been stated, it is difficult to overestimate the role of using the mechanized tools that are at construction sites at their maximum

efficiency, and maintaining the proper system for their use, technical maintenance, repair, registration and storage. The system of forming small mechanization administrations and sections has completely justified itself. TsNIIOMTP worked out and distributed through Stroyizdat the necessary normative and methodological documentation: "The procedure for Organizing Tool Management in Construction," "Basic Procedures for the Tasks and Functions of Small Mechanization Administrations in Construction" and others.

Often small mechanization administrations and sections consistently show high technical and economic results and have a positive effect on improving labor productivity in the organizations they serve (for example, MM [small mechanization] administrations in the Main Omsk Industrial Construction Administration in the USSR Ministry of Industrial Construction, the Moldavian SSR Ministry of Rural Construction, and the Energostroyemkhanizatsiya [Power Construction and Mechanization] Trust in the USSR Ministry of Power and Electrification).

However, the transition to a progressive form of organizing the use of mechanized tools and small machines is still being implemented, on the whole, slowly. At the present time only 50 small mechanization administrations and 1,500 sections are operating in construction and they are servicing no more than 30 percent of the existing fleet of mechanized tools and construction and finishing machines.

With the growth of NTP the complexity of the tools used in construction also increases and the requirements for observing rules for using and storing them increase correspondingly. Teaching workers the rules for handling tools, strengthening labor discipline, and increasing direct material responsibility for conserving tools, using them properly and for quality repair work is one of the most important aspects of organizing tool management in construction.

A number of problems associated with the structure of small mechanization subdivisions and workers' pay require quick resolution. For example, up to now the State Committee for Labor and Social Problems has still not approved the typical structures and staffs for the subdivisions and the USSR Ministry of Finance has not approved the payment classification for ITP [engineering and technical personnel] even though the necessary calculations and proposals have already been worked out by TsNIIOMTP and VNIPI [All-Union Scientific Research and Design Institute] for construction labor.

Several legal statutes concerning labor are needed to make adjustments toward increasing responsibility for the quality of work, and for damaging and losing tools.

Automotive transport is an important link in mechanizing construction production whose proportion exceeds 90 percent of all the construction cargo that is transported and which uses more than 1,200,000 people to operate it.

TsNIIOMTP has been doing research and development work over the course of more than 10 years in the field of specialized automotive means of transportation in construction (SATS). During this period a SATS system was created which is

based on the principle of uniform structural approaches and the types and typical sizes for a number of SATS were worked out in accordance with which structural documentation has been worked out and more than 50 size types of SATS were tested and are being serially produced. As a result the number of size types of SATS that are used in construction has been sharply reduced. Of more than 630 in 1977 and 1979 only 83 remain at the present time (smaller by a factor of 7.5).

At the present time practically the entire fleet of specialized motor vehicle means of transportation in construction (and there are more than 25,000 units) are made up of machines that are manufactured in accordance with the types developed by TsNIIOMTP based on working drawings by TsNIIOMTP or based on drawings that were worked out by construction ministry institutes on the basis of TsNIIOMTP technical requirements. The real economic return during this period amounted to more than 150 million rubles, 10,000 worked were conditionally freed and more than 10,00 tons of metal and 80,000 tons of conventional fuel were saved.

A new generation of SATS is being made that is capable of unloading itself on the basis of which a construction cargo delivery system is being worked out using standardized containers including those that can carry large tonnage. The production testing of a complete delivery system of construction combine products to the construction site which is going on at the present time can serve as an example. Its use makes it possible to exclude the installation crane from participating in operations to unload the components and materials that are delivered to the construction site and when this is done conditions are created for the steady pace of work and the reduction in the length of time to erect buildings.

The formation of a SATS for construction is especially urgent in association with the extensive development of the highly industrialized completely modular method of erecting structures which should unconditionally become the core for further industrializing construction. At present there is already an urgent need for making special self-propelled trailers with a load-capacity of up to 1000 tons which are controlled by a hydraulic system for raising and lowering a platform and a number of other specialized machines.

The specialization of means of transport in construction based on a typical size series of standard machines including those with electronic and hydraulic control systems is an important route for NTP in transportation work. Therefore the situation which now exists should change where the development of specialized means of transportation for construction is only a matter that concerns builders and the Ministry of the Automotive Industry practically takes no part.

Ninety-one percent of the fleet of automotive transport in construction is comprised of general-purpose machines at a time when specialized machines for construction should make up no less than 45 percent of the fleet according to calculations made by TsNIIOMTP. Bringing the automotive fleet up to the optimum mix would make it possible to free 120,000 people (10 percent of the workers engaged in operating transport) just by improving labor productivity

in transport work. The potential effect on the construction work that is served by automotive transport could be significantly large.

The overwhelming portion of the SATS now being used in construction is manufactured in automotive repair plants and automated mechanized shops in construction ministries and departments and their technical level is not always very high by far since the capabilities of these enterprises are limited in technically equipping and completely outfitting the products that are manufactured with modern materials, equipment and devices. Construction workers do not have completely self-propelled specialized motor vehicle earth movers, dump truck trailers and dump trucks with three-sided dumping which are badly needed, KRAZ [Kremenchug Motor Vehicle Plant] and MAZ [Minsk Motor Vehicle Plant] (6x4) type saddle tractors are not being delivered in sufficient numbers and semi-trailers for these tractors are not being turned out that completely take into account the specific requirements and needs of construction. Construction production presents a whole series of special demands on motor vehicle transport technology, however, the Ministry of the Automotive Industry is not taking these demands into consideration in the proper manner when designing general purpose base motor vehicles and specialized automotive machines.

From what was stated above the conclusion is taking shape that it is necessary and expedient to separate construction transport as an independent approach to motor vehicle manufacturing.

Accelerating the adoption of the achievements of NTP to mechanically outfit capital construction is one of the important assignments for TsNIIOMTP. The technological basis for long-term fleets of construction machines, working out their optimum structure and measures for achieving them in practice, taking into consideration changes that are occurring in association with the extensive adoption of NTP in the national economy as a whole, and the effect of these changes on construction and road machine building, the organization of construction production, and the technical implementation of construction and installation work--these are the directions of the Institute's research.

With the aim of increasing the influence of the construction technology consumer on its technical level measures are being taken at all stages of machine design: when technical requirements are worked out, when technical assignments are coordinated, when experimental models are tested, during state approval testing and when certifying the product's quality category. Increasing the amount and improving the results of research requires that the Institute's base be developed and equipped with modern equipment and devices.

It is also necessary to expand the list of industrial products for construction purposes for which the institute is the base organization for standardization. This will make it easier to conduct a uniform technical policy especially for the list of products of construction machines and devices that are turned out by construction ministries.

The amount of research on the reliability and serviceability of construction machines is increasing with the aim of reducing expenditures for technically servicing and repairing them.

The automation of construction processes and the use of robots and manipulators in construction are problems that also directly pertain to the institute. A system of construction robots and manipulators is now being created and the principle of standardized schemes was laid as its basis, the necessary GOST [state standards] and other normative documents are being worked out and specific components for manipulators that are for various purposes are being designed.

All the work to accelerate the adoption of the achievements of scientific and technical progress in construction is being done based on overall special purpose sector programs. With the development of similar programs for the 12th Five-Year Plan primary attention is being given to completing developments, adopting them in production and obtaining the maximum economic return.

COPYRIGHT: Stroyizdat, 1985

9495
CSO: 1821/135

CONSTRUCTION MACHINERY AND EQUIPMENT

SPECIFICATIONS OF DUAL WALL CONSTRUCTION METHOD VIEWED

Moscow ZHILISHCHNOYE STROITEL'STVO in Russian No 3, Mar 85 pp 22-24

[Article by Candidate of Technical Sciences I. S. Barshak, Engr D. K. Baulin of Moscow and Engrs V. I. Kravchenko and B. I. Madzhuga from the Pavlodar Housing Construction Combine: "Double-Layer Haydite-Concrete Panels for Exterior Walls"]

[Text] At present about 70 percent of the exterior walls in large-panel housing is manufactured from single-layer haydite-concrete panels. The mass use of these panels has been caused by the accessibility of the raw materials and by the relatively low labor intensiveness of production. However, due to the fact that the building materials industry in recent years almost everywhere has produced expanded shale aggregate with a bulk density of over 500 kg/m^3 and also in line with the increased requirements for the insulating properties of enclosure elements, the single-layer haydite-concrete panels in a majority of instances have ceased to meet these requirements.

Research conducted at the TsNIIEPzhilishcha [Central Scientific Research Institute for Standard and Experimental Designing of Housing] has shown that the thermal efficiency of exterior walls can be increased by approximately 20 percent by employing double-layer panels with an insulating layer from honey-comb (sandless) haydite concrete. The double-layer panels include an inner bearing layer 100 mm thick employing M-150 grade haydite concrete using quartz sand, an insulating layer 160, 210 or 260 mm thick from honey-comb haydite concrete of the M 35 grade and an exterior protective layer 40 mm thick from a sand-cement grout of the M 100 grade. The total thickness of the panels is 300, 350 and 400 mm.

The use of the honey-comb haydite concrete of the M 75 grade in the insulating layer instead of the M 75 compact-structure haydite concrete used in the single-layer elements makes it possible to improve a number of the operating and economic indicators. Here the coefficient of heat transmission in the insulating layer is reduced by an average of 35-40 percent. The amount of free (not cement-bound) mixing water is reduced by approximately 2.5 fold and this creates prerequisites for lowering the wall moisture indicator in the initial period of use. The insignificant water-retaining capacity of the honey-comb (sandless) concrete as well as the almost complete lack of capillary migration ensure the high draining properties of this material. The combination of low

water retention and high water vapor permeability determines the rapid drying of the concrete and its high frost resistance. The sufficient frost resistance of the low-strength honey-comb concrete is explained, as research has shown, by the presence of dense shells of vacuum-sealed cement rock around the granules of the porous aggregate. Here winter moisture accumulation in the insulating layer is excluded as a consequence of the low water vapor permeability of the bearing layer which is made from high-strength haydite concrete.

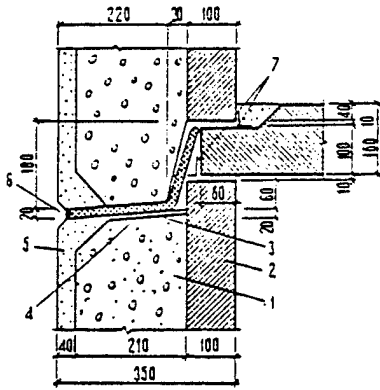

Fig. 1. Horizontal Joint of Double-Layer Panels
1--M 35 grade haydite concrete; 2--M 150 grade haydite concrete; 3--mortar and KN-2 protective compound; 4--rock wool bundle; 5--protective layer from M 100 grade mortar; 6--mortar; 7--'gerlen' tape [possibly--sealer tape]

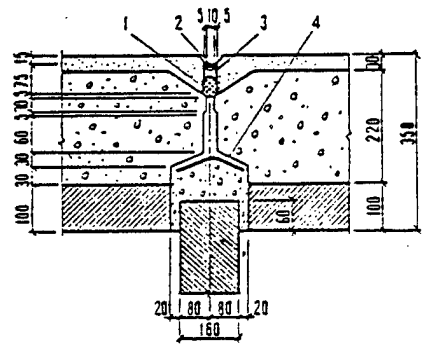

Fig. 2. Vertical Joint of Double-Layer Panels
1--porous packing layer; 2--polymer-cement mortar; 3--mastic; 4--'gerlen' type tape.

The use of low-strength concrete in the insulating layer necessitates a change in the design of a horizontal joint of the double-layer panels (Fig. 1). The lower tooth of the panel formed from concrete of the insulating layer, in order to ensure the required strength during transport and installation, is made the entire width of this layer. A water-protective ridge is made from the strong concrete of the bearing layer and receives all the vertical stresses, being simultaneously the support for the floor slabs. The horizontal joint is insulated with rock wool plates laid in the cavity under the tooth or lug in the area of the insulating layer and attached to the lower panel (in the area of the honey-comb concrete).

Insulation against the leaking of a horizontal joint is ensured by "gerlen" tape glued in the joints between the water protective ridge and the floor slab as well as in the angles formed by the upper surface of the floor slab in the support area and the surface of the bearing layer of the exterior wall panel. Sealing the opening of a horizontal joint is not carried out in order to prevent the accumulation of rain water in the joint cavity. In order to prevent the draining of water through the insulating layer of the panels, the upper

edges are coated with mortar and covered with KN-2 glue. Vertical joints of the double-layer panels (Fig. 2) are the same as the joints of single-layer panels, but here the side edges of the panels are coated with mortar.

Double-layer panels of the described design and 350 mm thick, as developed by the TsNIIEPzhilishcha and the Pavlodar DSK [housing construction combine] for five- and nine-story buildings of the 121 series have been employed in Pavlodar and Pavlodar Oblast since 1981. Up to the present, more than 40 prefab sections have been erected in Pavlodar, Yermak and Ekibastuz. The State Standard 11024-84 "Exterior Concrete and Reinforced Concrete Wall Panels for Housing and Public Buildings. General Technical Conditions" includes the double-layer panels along with the others.

At the Pavlodar DSK, for the inner bearing layer (haydite concrete of the M 150 grade), the following formula was adopted for the haydite concrete mix per cubic meter: 250 kg of M 400 grade cement, 0.8 m³ of haydite of the 0-20 mm fractions, 0.52 m³ of quartz sand and 185 l of water. Here the bulk density of the haydite was 550-600 kg/m³ while the density of the dry concrete was 1550-1600 kg/m³. For the insulating layer made from honey-comb haydite concrete of the M 35 grade, the following formula was adopted for the concrete mix per cubic meter: 220 kg of M 400 grade cement, 1.05 m³ of haydite with a fraction of 5-40 mm (with the removal of sand with the fraction of 0-5 mm) and 125 l of water. The bulk density of the haydite was 470-520 kg/m³ and the density of the dry concrete was 780-820 kg/m³.

The Pavlodar DSK manufactures the double-layer panels on a conveyor line with extension curing rooms; the line is equipped with two forming stations. At the first forming station, using a vibrating table, they first lay the decorative grout for the outside protective layer and then the honey-comb haydite concrete mix for the insulating layer. The length of the vibration treatment for this mix should not exceed 5-8 seconds in order to prevent separation. At the second forming station they lay the haydite concrete mix for the inner bearing layer. The compacting of the mixes is carried out by a concrete layer with vibroplating and the vibrating table shut off.

To facilitate the forming process initially they planned to pour the double layer panels "face up." Subsequently a decision was taken to pour the panels "face down," since this method would provide greater variation in the finishing of the face and increase the crack resistance of the exterior protective layer. Consequently, the double-layer panels can be manufactured "face up" and "face down" on the existing conveyor lines for producing the single-layer elements if the lines are equipped with a vibrating table and a series-produced concrete layer with vibroplating; it is merely necessary to change the long sides of the forms.

It should be pointed out that the production of the double-layer panels for exterior walls is more labor-intensive in comparison with the single-layer ones basically due to the additional work involved in using the honey-comb sandless concrete: the trowel finishing of the upper and side edges of the panels and the side and lower edges of the window opening as well as the gluing of the joints between the floor slab and the panels with gerlen tape. The

increased labor intensiveness of forming the double-layer panels, in comparison with the single-layer ones, is insignificant as both elements are formed from three layers of concrete and mortar of varying composition. At the same time, the use of the double-layer panels makes it possible to abandon the sealing of the horizontal joints with the use of porozol [possibly--joint compound] and non-hardening mastic. At present work is being done to further improve the joints by increasing the convenience of the work and the reliability of the wall enclosures.

Actual studies conducted during the first 2 years of the operation of the buildings confirmed that the double-layer panels for exterior walls as produced by the Pavlodar DSK met the operating conditions placed on them, including for insulating. No instances were noted of leaking joints. In order to prevent individual operating flaws related to the failure to observe manufacturing conditions, control was strengthened over the thickness of the inner bearing and the insulating layers and the density of the honey-comb haydite concrete. Limiting the density to an amount of 850 kg/m^3 was achieved by employing expanded shale aggregate with a bulk density not over 520 kg/m^3 with the obligatory removal of porous sand, that is, fractions under 5 mm.

The area of the possible use of the double-layer wall panels is the regions of the dry climatic zone of the nation, where presently they are using the single layer panels from haydite concrete with an aggregate of the M 500 grade and over. At present these regions are erecting over 23 million m^2 of total housing area per year and this is approximately 25 percent of the total volume of large panel construction in the nation.

In comparison with the traditional single-layer panels for exterior walls using haydite concrete with porous sand, the use of the double-layer wall panels, according to the data of the TsNIIEPzhilishcha, will make it possible to increase the resistance to heat transfer by 18-25 percent and correspondingly reduce expenditures on heating the buildings; to reduce haydite consumption by 0.16-0.21 m per square meter of panel with the same panel thickness by abandoning the use of crushed haydite sand and the porous structure of the insulating layer, as well as lower the adjusted expenditures calculated per square meter of panel (minus the window opening) by 3-4 rubles or by 1.8-2.4 rubles per square meter of total area (in terms of the conditions in Pavlodar).

COPYRIGHT: Stroyizdat, 1985

10272

CSO: 1821/134

CONSTRUCTION MACHINERY AND EQUIPMENT

UDC 666.940:947.086.088

HIGHLIGHTS OF DEVELOPMENT OF SOVIET CEMENT INDUSTRY VIEWED

Leningrad TSEMENT in Russian No 5, May 85 pp 1-4

Article: "USSR Cement Industry During 40 Peaceful Years"

Excerpts In October 1943, two months following liberation, the Amvrosiyevka plants produced their initial batches of cement and in 1944 the Novorossiysk, Leningrad, Dneprodzerzhinsk and Volkovysk plants commenced their production of cement. Plants in Moscow and Volsk and also those in Siberia and the eastern regions increased their production.

This made it possible in 1947 to achieve the pre-war production level for cement and in 1948 6.45 million tons of cement were produced, or 13 percent more than the pre-war level. Fifty one enterprises were in operation at this time compared to only 46 in 1940.

In 1962, the country's cement production amounted to 57.3 million tons, or 1.3 million more tons than the figure for the U.S.A. and by 1977 this production had reached 127 million tons, or 16.6 percent of overall cement production throughout the world.

Thus, over a period of 32 years the cement production volume in the USSR increased by a factor of 70.6 compared to 1945 and was satisfying for the most part the construction requirements. Moreover, our annual average increase in cement production is 12 percent and in the U.S.A. -- 3 percent.

Compared to 1940 when cement was produced for the most part in the RSFSR and UkSSR and also in small amounts in Belorussia, Latvia, Estonia, Georgia, Azerbaydzhan, Armenia and Uzbekistan, in 1961 such production was distributed in the following manner: 64.8 percent in the RSFSR, 17.7 percent in the UkSSR and 18.3 percent in the remaining union republics. With cement production throughout the country increasing by a factor of 2.5 during the 1961-1977 period, its production in union republics (excluding the RSFSR and UkSSR) increased by more than fourfold.

As a result, a reduction took place in the radius for cement shipments and it became possible to carry out more rapid construction of industrial enterprises in previously backward regions of Central Asia, Kazakhstan, the Trans-Caucasus, Siberia and the Far East.

A typical feature of branch development during this period was an increase in the capabilities of the plants. Compared to 1940 when the average production of cement by one plant amounted to 123,000 tons, in 1948 -- 127,000 tons, in 1962 it reached 667,000 tons and in 1977 -- 1,380,000 tons, including at enterprises of USSR Minstroyaterialov /Ministry of the Construction Materials Industry/ -- 1,486,000 tons.

The concentration of cement production was ensured through the development and production, by enterprises of USSR Minstroydormash /Ministry of Construction, Road and Municipal Machine Building/, of new equipment and the placing in operation of heavy-duty rotary furnaces for the wet production method measuring 4.5 X 170 and 5 X 185 meters, a mill measuring 4 X 13.5 meters and mills for the wet self-milling of raw materials and technological lines for the dry production method with rotary furnaces measuring 5 X 75 and 6.4 X 95 meters, equipped with heat exchangers.

There are presently in operation 100 furnaces (length from 170 to 230 meters) for the wet production method and 33 furnaces for the dry method with heat exchangers, including six heavy-duty units. In 1961, the principal type of furnace measured 3.6 X 150 meters and had a productivity of 25 tons per hour and in 1982 industry was equipped with furnaces measuring 5 X 185 meters and having a productivity of 72 tons per hour.

Increases were achieved also in the productivity of milling units, as a result of more powerful units measuring 4 X 13.5 meters being installed in place of mills measuring 2.2 X 13 and 2.6 X 13 meters.

With the introduction into operations of heavy duty furnaces for the wet and dry methods of production, reductions took place in the specific consumption of conventional fuel for the roasting of clinker during the period from 1961 to 1982 of 50.3 kilograms per ton and also during this period there was a reduction of 2 kilowatt-hours per ton of cement in the specific consumption of electric power, with a substantial improvement taking place in the cement assortment. For example, with an overall increase in the cement production volume by a factor of 2.7 during the 1960-1982 period, the production of Portland cement increased by a factor of 4.2, tamping cement -- by a factor of 3.5 and sulphate-stable, highway, sand and decorative cement -- by a factor of 8.

An important stage in the development of the branch was the automation of production, which was started in the 1950's. During the initial period, numerous local units were created based upon similar regulators for controlling and stabilizing the operation of individual mechanisms and also for controlling certain technological processes: milling, mixing, drying and roasting.

Towards the end of the 1960's, more than 600 such units were introduced into operations and a complex of operations was also carried out in connection with the development and production of remote control units.

The creation of the Soyuzavtomatstrom VNPO /All-Union Scientific Production Association/ made it possible to carry out a complete cycle of operations -- from the carrying out of studies to the industrial production of instruments and units for automatic control and for regulating and controlling technological

processes. This promoted improvements in the efficiency of cement production as a result of greater reliability and efficiency in the carrying out of the technological processes and it also created conditions for the further development of work concerned with automation.

The Tsement-1 ASU automatic control system was introduced into operations in 1972 at the Sebryakovskiy Plant. In one way or another, this system encompassed all aspects of the work being carried out at the enterprise. Its introduction into operations made it possible to increase the productivity of the rotary furnaces by 2 percent, that of the cement mills -- by 6 percent, to lower specific fuel and electric power consumption by 2-4 percent and also to achieve an increase of 10 percent in the average grade of the cement. But the most important consideration was the fact that this system provided extensive opportunities for production automation.

During the years of the 9th Five-Year Plan, the Soyuzavtomatstrom Association introduced approximately 30 ASUTP's automatic system for controlling a technological process into operations in the construction materials industry, during the 10th Five-Year Plan their number increased to 50 and for the 11th Five-Year Plan the plans called for the creation of 70 ASUTP's, with the cement industry accounting for more than one half of these systems.

Today these ASUTP's are being used on technological lines for the dry production method at plants in Novokaragandinsk, Novospasskiy, Navoi, Lipetsk and others and this indicates that the developers and production workers have mastered the methods employed for utilizing the great opportunities afforded by modern ASU's. The economic effect realized from the automation of cement production during the 10th Five-Year Plan amounted to approximately 10 million rubles.

A promising trend in the development of automation has been the creation of automated technological complexes (ATK's). Experience accumulated in the systematic planning of ATK's at the Rezina and Krivoy Rog plants has shown that this brings about a substantial simplification in the technological systems, a decrease in capital investments and operational expenses and a considerable reduction in the consumption of fuel-energy and material resources and also in the number of personnel per unit of output.

During the post-war years, scientific studies were carried out on an extensive scale in connection with the principal problems of cement chemistry and technology, with large numbers of scientists and engineers participating in this work.

As work was carried out in connection with the restoration of destroyed enterprises and the construction of new ones, the all-round brigades of Giprotsement All-Union State Scientific Research and Planning Institute of the Cement Industry in Kharkov and Novorossiysk were converted into branches of the institute and a branch of Giprotsement was also created in Novosibirsk. Subsequently, independent institutes were founded based upon these branches: Yuzhgiprotsement, Novorosgiprotsement (now NIPIOTstrom) and SibNIIproyektsement and, in addition, the State All-Union Scientific-Research Institute of the Cement Industry (NIItsement) was created.

A basic VUZ for the USSR Ministry of Materials -- the Belgorod Technological Institute of Construction Materials -- was founded in 1970 for the training of engineering personnel.

The departments of the new institute and the specialized departments of MKhTI imeni D.I. Mendeleev /Moscow Institute of Chemical Technology imeni D.I. Mendeleev, LTI imeni Lensovet /Leningrad Technological Institute imeni Lensovet/, the Novochoerkassk Polytechnical Institute and a number of other educational institutes and also the Institute for the Chemistry of Silicates of the USSR Academy of Sciences are actively participating in the carrying out of scientific-research work for promoting the development of the cement industry.

The compositions and technology for producing many new types of cement were developed: tamping cement for cold and hot wells, highway cement, cement used for the production of asbestos-cement products, high strength cement, rapid hardening cement, ultra rapid hardening cement, alumina cement, expanding cement, pressure cement and a number of others.

The development of energy conserving technologies and improvements in the cement quality and assortment resulted from work performed by workers attached to the scientific portion of the branch's oldest institute -- Giprotsement -- which from 1950 to 1980 was directed by bearer of the Order of the Patriotic War B.V. Volkonskiy.

A specialized technical council was created at Giprotsement for the development of equipment, which with the aid of leading designers from heavy machine building prepared the technical plans for the principal technological units to be used for cement production. Based upon these units, Giprotsement developed the standard plans for the technological lines and plants having rotary furnaces measuring 4.5 X 170 and 5 X 185 meters.

The carrying out of scientific-research works based upon all-round scientific-research programs -- three state and nine branch programs -- was started during the 11th Five-Year Plan.

Energy conserving technologies are being developed and introduced into operations, auxiliary operations are being mechanized, the problems concerned with improving the quality and assortment of cement are undergoing further study and utilization of the technogenic waste products of other branches of industry is being expanded.

The extensive scale of the scientific work is borne out by the fact that it calls for the creation of more than 30 new technologies and approximately 20 new units of mechanized equipment. Distinct from past years, the orientation is not only to the carrying out of studies but also to the introduction into production of a majority of the works.

The carrying out of the all-round programs will make it possible to realize annual savings of approximately 150,000 tons of conventional fuel and more than 200 million kilowatt hours of electric power, expand the production of high strength, pressure, decorative, tamping and other types of cement, realize an economic effect in the amount of 78 million rubles and ease the labor of 2,000 workers.

These tasks are rather complicated: the state and branch programs for the cement industry include approximately 100 tasks, each of which is an independent work. In addition to leading institutes, approximately 40 co-executor organizations participate in the work concerned with carrying out these tasks.

A number of tasks have already been carried out. For example, NIItsement and the Perm branch of the All-Union Scientific-Research Institute of the Pulp and Paper Industry developed a super-plasticizer based upon modified ligno-fulphonates -- LSTM-2. Its addition during the milling of cement raises the specific surface of the cement by 300-500 square centimeters per gram and with no reduction in the productivity of the mills.

The use of Portland cement Mark 550 with an LSTM-2 additive makes it possible to save from 10 to 14 percent of the cement per cubic meter of concrete compared to Portland cement Mark 500 and to improve by twofold the application of concrete mixtures with no reduction in strength.

The industrial production of this super-plasticizer has been organized at a pulp and paper combine where a unit capable of producing 10,000 tons of additive annually has been placed in operation, an amount that is sufficient for the production of more than 2 million tons of cement. Use of the LSTM-2 plasticizer began in 1982 at the Sebryakovskiy Cement Plant and the Amvroseyevka Combine.

NIItsement, jointly with Yuzhgiptsement and the Institute of Colloidal Chemistry and the Chemistry of Water of the UkSSR Academy of Sciences, proposed the use of synthetic crystalline components (krents), obtained from kaolins and waste products roasted in advance and containing sulphuric acid or iron sulphate.

Within the framework of the program, the initial batches of the krents were obtained at experimental plants of NIItsement and Yuzhgiptsement and used at the Podolsk Experimental Cement Plant and the Amvroseyevka Combine for the production of high strength Mark 550 and Mark 600 cement.

The heat expenditures for the roasting of kaolin for krents amount to roughly 25 percent of the theoretical expenditures for clinker formation. When 5-10 percent of the clinker is replaced by krent, a fuel savings of approximately 75 percent is realized (proportional to the amount of clinker replaced). In addition, the krents are milled considerably easier than clinker and the milling of krents is intensified by 20-25 percent and when the former grade of the cement is retained -- by 35-40 percent and this makes it possible to lower the consumption of electric power.

A new technology for the combined bleaching of clinker instead of water treatment has been developed at NIItsement and introduced into operations at the Shchurovskiy plant. This made it possible to remove a drying drum from the technological line, to improve the degree of whiteness considerably and to increase the production of high grade white cement. As a result, the plant's profits increased by 450,000 rubles in 1983.

The institute also proposed and introduced into use at more than 100 mills a protective lining made out of rolled elements with a variable coefficient of cohesion. An economic effect in excess of 3 million rubles annually was achieved as a result of the cheap nature of this action and an increase in service life.

Giprotsement implemented improvements in a system for the decarbonization of flour in a shaft-cyclone heat exchanger by means of gas combustion in moulds of a shaft of Furnace No. 3 at the Katav-Ivanovo plant. In 1983 this method was employed for producing approximately 200,000 tons of clinker and a productivity of 51.4 tons of clinker per hour was achieved.

With the participation of workers from the institute, work was carried out at the Novospasskiy plant in connection with optimization of the roasting regime on furnaces with cyclone heat exchangers and experiments were completed on mastering the production of Grade 500 cement using closed cycle mills and optimum operating regimes were also developed for a milling unit which serve to ensure that this grade of cement will be obtained. The average productivity of the mill was 90 tons per hour and specific electric power consumption -- 43.3 kilowatt-hours per ton, for the milling of cement to a specific surface of 3,500-4,000 square centimeters per gram.

A mathematical model has been created at Giprotsement for the raw material decarbonization process for use with the dry method for cement production.

With the participation of workers from the institute, work was completed on the installation and placing in operation of a milling unit on a technological line at the Savinskiy plant, the structure of which includes a mill for wet self-milling measuring 7 X 23 meters and a finishing mill measuring 4 X 13.5 meters. In the process, the planned productivity of the technological line -- 130 tons per hour for dry raw materials -- was achieved.

Recently the principal efforts of Giprotsement, with regard to creating a radiation-chemical technology for obtaining cement, have been directed towards completing the construction at Novosibirsk of an experimental unit with an estimated productivity of up to 50 kilograms of clinker per hour, which was accepted in 1984 by the state committee and furnished its initial hundreds of kilograms of clinker.

As a result of all-round studies and full-scale testing, workers at Yuzhgiprotsement developed a low energy-intensive, sulphate-stable slag Portland cement, which calls for the use of chemical industry slag. This cement is characterized by a higher coefficient of stability in aggressive mediums than is found in other types of cement and distinct from the more commonly used sulphate-stable Portland cement it hardens more intensively during raised temperatures.

The high degree of savings realized in the production of this new type of cement results from a reduction in the consumption of clinker. As a result, fuel consumption decreases by 30 percent and the stability of the concrete, as a result of a reduction in expenditures for its special protection -- by 20-25 percent. For having developed and introduced this sulphate-stable slag Portland cement, a group of the branch's specialists was awarded the prize of the USSR Council of Ministers for 1983.

With the aid of Yuzhgiprotsement and with the participation of workers from MKhTI imeni D.I. Mendeleev, a new R-roasting technology was introduced into operations at the Lipetsk plant, which ensures a reduction in specific fuel consumption for the roasting of clinker and an increase by a factor of 1.5-2 in the productivity of the furnace unit, the activity of the clinker and also in the stability of the lining in the clinking zone.

By carrying out the decisions handed down during party congresses and plenums of the CPSU Central Committee and also the decrees of the party's Central Committee and the USSR Council of Ministers and by introducing into production the latest achievements of chemistry and cement technology, the collectives of cement enterprises and scientific and planning organizations and also scientist cement workers will ensure further development for the production of a most important construction material -- cement.

COPYRIGHT: Stroyizdat, zhurnal "Tsement", 1985

7026

CSO: 1821/137

CONSTRUCTION MACHINERY AND EQUIPMENT

SHORTAGE OF CONSTRUCTION MATERIALS NOTED IN KIRGHIZIA

Moscow EKONOMICHESKAYA GAZETA in Russian No 24, Jun 85 p 17

[Article by Ye. Kozlov, EKONOMICHESKAYA GAZETA correspondent : "Orienting Towards Yesterday?"]

[Text] For several years in a row the Kirghiz SSR Ministry of the Construction Materials Industry has not fulfilled its plan assignments on many important indicators. One of the reasons for this is the low technical level of the sector's enterprises. Here, in essence, only glass production meets current requirements, while other subsectors have nothing to brag about. We must say that all 11 of the ministry's brick plants are producing their goods by the old-fashioned method. New economic processes are also not being introduced in cement production.

It would seem that under these conditions the ministry's managers should pay primary attention to the introduction of scientific-technical achievements into production. However, this work sector has been put on the back burner here. The facts testify to this. Last year, 13 out of 44 plan topics on this sector were not fulfilled. However, even those measures which have been implemented bear more of a subsidiary character.

One exception is probably the work on developing equipment for mining and processing natural stone. The ministry has established long-term business ties with the scientists at the Kirghiz SSR Academy of Sciences, who have helped the production workers. This cooperative effort has developed several heavy and light modern machines for extracting marble, shell rock, and other natural materials. Many buildings have been finished in stone, which decorates them and does not require further expenditures for painting, whitewashing, or other work.

However, this approach to the matter has not become the style of work for the ministry. Here they generally spend their time patching holes in old technologies.

"For radical scientific-technical innovations," says Deputy Minister V. Prozorov, "large capital investments and a good construction base are needed. The situation is difficult with funds, but still they can be found. The case is worse with the construction base. We do not have our own, and the contractors do not fulfill the outlined plans."

It is possible that there is some reason in such a formulation. Thus, the ministry has developed a program of technical retooling for brick making plants for 1984-1985 and for the period to 1990. However, this program is not being implemented. Among other reasons is the poor work by the builders. For example, last year the republic Minsel'stroy [Ministry of Rural Construction] performed work in the sum of 63,000 rubles for the reconstruction of the Talasskiy Brick Plant, with a plan of 444,000. There were also no changes for the better in the current year. A modern automatic brickmaking plant is being built in the city of Tokmak. By the way, this facility was bought by import. However, last year the plan was fulfilled by less than 20 percent.

Minstroyaterial [Ministry of Construction Materials Industry] also has other difficulties. For example, part of the non-standardized equipment practically cannot be ordered anywhere, and must be manufactured through in-house efforts, generally at low-capacity repair enterprises.

At the proposal of superior departments, the Kantskiy Cement-Slate Combine has been assimilating a new technology developed by scientists for the production of so-called stressing cement. The technology was perfected, and the plan called for the combine to turn out 20,000 tons in 1984. The fulfillment of this task would bring honor both to the enterprise and the ministry. However, not a single ton was produced. The same assignment was again planned for the combine for the current year. In the first quarter the combine was to have submitted 5,000 tons of stressing cement. Not a single ton was submitted.

The director of the combine's production-technical section, N. Poleskaya, says directly: the enterprise is not fulfilling its task because it has found itself unprepared for this work. The new technology requires great precision and reliability of the equipment, and it is in poor condition at the combine.

What, then, are the prospects? The chief of the ministry's technical section, G. Druzhinin, explains that the combine generally operates poorly and does not even fulfill its standard production program. "As soon as we stabilize its position and take it out of the hole, then it will be easier to manufacture the new cement and to expand the warehouse capacities."

This is the logic behind the thinking of the section chief. However, this is a vicious circle: we have no time for technical progress, we are merely trying to mend the holes as best we can. Yet without technical progress there cannot be good work.

The listless work by the ministry on scientific-technical progress has many other negative consequences. In brick production, for example, the level of manual labor comprises 60 percent, the expenditure of specified fuel per ton of clinker exceeds 241 kilograms with an assigned figure of 230 kilograms, and the plan for output of highest grades of cement is not being fulfilled. The Ministry must make a sharp turnaround and, utilizing the scientific-technical achievements, work with perspective.

12322
CSO: 1821/141

- END -