

FC Series - NEMA 3R outdoor enclosures with UL Listed fans, filters, and thermostats

"FC" Series include fans

BW-124-8-FC

24"W x 24"H x 8"D with a 115V, 131 cubic-foot/min. fan and thermostat



BW-124FC

24"W x 24"H x 12"D with a 115V, 300 cubic-foot/min. fan and thermostat

BW-136FC

24"W x 36"H x 12"D with a 115V, 300 cubic-foot/min. fan and thermostat



BW-RACKFC

22"W x 12RU H x 24"D with a 120V, 300 cubic-foot/min. fan, thermostat, and an internal 19" rack

Add a "W" at the end of these part numbers for an optional window in the door.

BW-FC16147

16"W x 14"H x 7"D non-metallic, with a 115V, 81 cubic-foot/min. fan and thermostat



BW-FC181610

18"W x 16"H x 10"D non-metallic, with a 115V, 81 cubic-foot/min. fan and thermostat

NEW BW-FC20168

20"W x 16"H x 8"D non-metallic, with two 115V, 81 cubic-foot/min. fans and thermostat

BW-FC242410

24"W x 24"H x 10"D non-metallic, with two 115V, 81 cubic-foot/min. fans and thermostat



“FC Series” Outdoor, NEMA 3R, Fan-Ventilated, Electrical Enclosures

Table of Contents

Installing the fans, gaskets, and shrouds into **METAL** FC Series Enclosures

Page 1

- BW-124-8-FC - 24”W x 24”H x 8”D with a 115V, 131 cubic-foot/min. fan
- BW-124FC - 24”W x 24”H x 12”D with a 115V, 300 cubic-foot/min. fan
- BW-136FC - 24”W x 36”H x 12”D with a 115V, 300 cubic-foot/min. fan
- BW-RACKFC - 22”W x 12RU H x 24”D with a 120V, 300 cubic-foot/min. fan

Installing the fans, gaskets, and shrouds into **POLYCARBONATE** FC Series Enclosures

Page 2

- BW-FC16147 - 16”W x 14”H x 7”D non-metallic enclosure, with a 115V, 81 cubic-foot/min. fan
- BW-FC181610 - 18”W x 16”H x 10”D non-metallic enclosure, with a 115V, 81 cubic-foot/min. fan
- BW-FC20168 - 20”W x 16”H x 8”D non-metallic enclosure, with a 115V, 81 cubic-foot/min. fan
- BW-FC242410 - 24”W x 24”H x 10”D non-metallic enclosure, with two 115V, 81 cubic-foot/min. fans

Installing the thermostat with one or two fans

Page 3-4

- Installing **ONE** fan to the thermostat, page 3
- Installing **TWO** fans into the thermostat, page 4

Warranty, Technical Support and Shipping Carton Contents Information

Page 5

Installation Examples

Page 6

Drawings of individual models

Page 7-14

FC Series units include:

- UL Listed fans
- Filter kits
- Thermostats
- Protective Shrouds for NEMA 3R rating
- Exterior mounting ears
- Air-intake and air-exhaust ports
- Locking or pad-lockable doors

Options include windows, pole-mount kits, interior removable panels/shelves/racks, graphics, customization, and 12V, 24V, 48V, or 230V Fans!



Installation Instructions

Mier Products' Metal, Fan-Ventilated, NEMA 3R, Enclosures

URGENT!
Handle with care during shipping, storage, and installation.

The Fans and Shrouds must be mounted to the enclosure using the pre-cut holes and supplied gaskets. The Fans must be installed in the proper position.

Follow all OEM instructions to maintain NEMA rating and proper performance.

ATTENTION:
WATERTIGHT FITTINGS
MUST BE USED ON ALL
OPENINGS!

When installed properly per OEM's specs:

- * Enclosure is **NEMA 3R** standards
- * Powder-coat meets **NEMA 4, UL-1332**
- * Gaskets meet **NEMA 4, UL-50** and **UL-94-HB** Flammability Rating

Shroud and Fan Installation for BW-1248FC, BW-124FC, BW-136FC and BW-RACKFC:

The fans are placed inside the shrouds to protect them during shipping. The fans are continuous-duty **unless** you install the thermostat.

1. Remove Shrouds, Fans, Filter Kit, Thermostat, and Hardware from the inside of the enclosure. **DO NOT TO GOUGE** the paint
2. Feed the Fan Cord through the Double-D Hole in the enclosure (Note: Do not connect the cord to the fan terminals yet)
3. Install the Fan on the **LOWER RIGHT-HAND SIDE** opening of the enclosure (note: Tamper Switch Bracket is on the upper-right hand side), putting the **FAN on the OUTSIDE** of the enclosure with the Fan-Power-Terminals near the Double-D Hole, using the four (4) long #8x32x2.5 bolts, screws and nuts. Fan airflow direction is marked on the fan with a simple that looks like a numeral 1 as an arrow **1**. The air should flow *into* the enclosure.
4. Grounding: attach the fan to one of the threaded standoffs in the enclosure with a ground wire. Ground standoffs on the fans are clearly marked.
5. With a minimum of 2.25" of fan-cord and ground-wire slack on the **outside** of the enclosure, install the Plastic Strain Relief over the fan- cord, snap it closed, and fit it into the Double-D Hole (**Figure 1** below shows completion of steps 3-5)
6. Snap apart the Filter Kits which include a Filter Guide with screw holes, a Filter, and a Snap Cover (**Figure 2** - Step 6)
7. Install the Filter Guides **ON THE BOTTOM OF THE SHROUDS** using four (4) 8x32x3/4" flat-head screws per shroud, making sure the Filter Guide rails face away from the shroud (**Figure 2** - Step 7)
8. Re-install the Filters in the Filter Guides and replace the covers (**Figures 2 & 3**)
9. Install the Rain Shrouds at the top and bottom openings with the **AIR HOLES FACING DOWN**. Use a 3/8" socket and the eight (8) #1/4x20x1/2 inch bolts for each Rain Shroud (**Figure 4** shows enclosure with rain shrouds attached)
10. The Fan may now be plugged into 115VAC for **continuous duty** (see **wiring to the thermostat instructions if you want the fan thermostatically controlled**). Installers will need to cut a conduit opening in the enclosure their specific installation.
11. Openings in the bottom of the Rain Shrouds should be checked periodically for debris blocking air flow
12. REMEMBER to clean or replace Filters a minimum of every six months. Do so more often in dust/pollen/debris/ ridden areas.

Figure 1

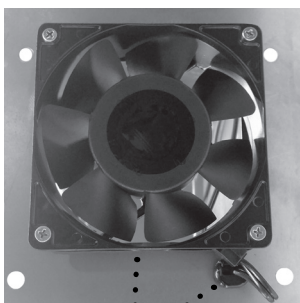

Fan installed with 2.5" of cord on the outside of the enclosure with the strain-relief in the Double-D cord hole.

Figure 2

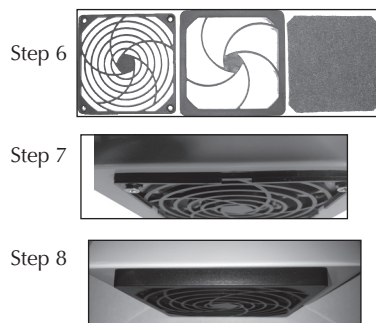

Figure 3



Figure 4



Installation Instructions

Mier Products' Polycarbonate, Fan-Ventilated, NEMA 3R, Enclosures

URGENT!
Handle with care during shipping, storage, and installation.

The Fans and Shrouds must be mounted to the enclosure using the pre-cut holes and supplied gaskets. The Fans must be installed in the proper position.



Follow all OEM instructions to maintain NEMA rating and proper performance.

ATTENTION:
WATERTIGHT FITTINGS
MUST BE USED ON ALL
OPENINGS!

When installed properly per OEM's specs:
* Enclosure is NEMA Type 3R standards
250-1997 (1000 volts maximum)

Shroud and Fan Installation for BW-FC16147, BW-FC181610, BW-FC20168 and BW-FC242410:

The **BW-FC16147, BW-FC181610, and BW-FC20168** have one fan and two shrouds. The larger **BW-FC242410** has two fans and four shrouds.

1. Connect the Fan Cord to the Terminals on the Fan 
2. Snap the Filter Retainer and the Filter off the Filter Bracket, and set them aside for later assembly 
3. Assemble the Fan to the upper fan opening, putting the Fan on the INSIDE, and the Filter Bracket on the fan itself. Use four (4) #8x32x1¾ inch screws and nuts. Fan airflow direction is marked on the fan with a simple that looks like a numeral 1 as an arrow **1**. The air should flow *into* the enclosure.
4. Grounding: attach the fan to one of the threaded standoffs in the enclosure with a ground wire. Ground standoffs on the fans are clearly marked.
5. Install the lower Filter Bracket(s) using four (4) #8x32x¾ inch screws and nuts. Leave a little slack in the Fan Cord so it does not pull from the Fan Terminals.
6. Install the Rain Shrouds at the top and bottom openings with the Air-Entrance Holes at the bottom (i.e. facing down). Use the six (6) screws and flat washers supplied for each Rain Shroud. 
7. Install Filters and Retainers by snapping onto the Filter Brackets
8. Fan may now be plugged into 115VAC for continuous duty (**see wiring to the thermostat instructions if you want the fan to be thermostatically controlled**).
9. Openings in the bottom of the Rain Shrouds should be checked periodically for debris blocking air flow
10. Fan Filter(s) should be cleaned or replaced a minimum of every six months, and more often in high dust//debris areas.



BW-FC16147



BW-FC181610



BW-FC20168



BW-FC242410

Installation Instructions

Connecting *ONE Fan To The Thermostat*

- 1-1. Set the Thermostat Control 70 to 75 degrees F for most installations. However, before determining the Thermostat setting for your specific application: you must consider the operating parameters of the equipment you are installing, specifically the operating temperatures, and take into consideration the temperature of the installation environment, seasonal changes, and the heat load of the electronics within. If the electronics are less than 100 Watts, and the installation is in a normal indoor temperature controlled setting, it is recommended to set the Thermostat to 80 degrees F
- 2-1. *If using two fans go to the next page. For models with one (1) fan, the fan should blow into the enclosure (Figure 1).* The fans are marked with an arrow that looks like a numeral 1 showing airflow direction **1**. You will only cut one of the wires on the fan's power cord if using one fan. Use a razor knife or other sharp thin blade to cut a small section of the two wires of the power cable apart. Pull the **Neutral/Smooth/Common Wire** and **Hot/Ribbed/Continuous Wire** apart from each other on the Fan Cord. **Cut the Hot/Ribbed/Continuous Wire** in half. The **Neutral/Smooth/Common Wire** remains attached to the plug.
- 3-1. Wire **Hot/Ribbed/Continuous Wire** from the Fan into **Terminal 1 of the Thermostat**, and the **Hot/Ribbed/Continuous Wire** from the Plug into **Terminal 2 of the Thermostat** (see Figure 1 below). This wires the Thermostat in series with the Fan.
- 4-1. Mount the Thermostat **INSIDE** the enclosure using the two-sided-tape supplied by placing it on one side of the enclosure. Another method is to mount an optional DIN Rail in the enclosure, and use the DIN Rail tabs on the back of the Thermostat.
- 5-1. Grounding: attach the fan(s) to one of the threaded standoffs in the back of the enclosure with a ground wire(s). Ground standoffs on the fans are clearly marked with an arrow that looks like a numeral 1 showing airflow direction **1**.
- 6-1. Plug the cord into 110/115VAC outlet paying attention to polarity.

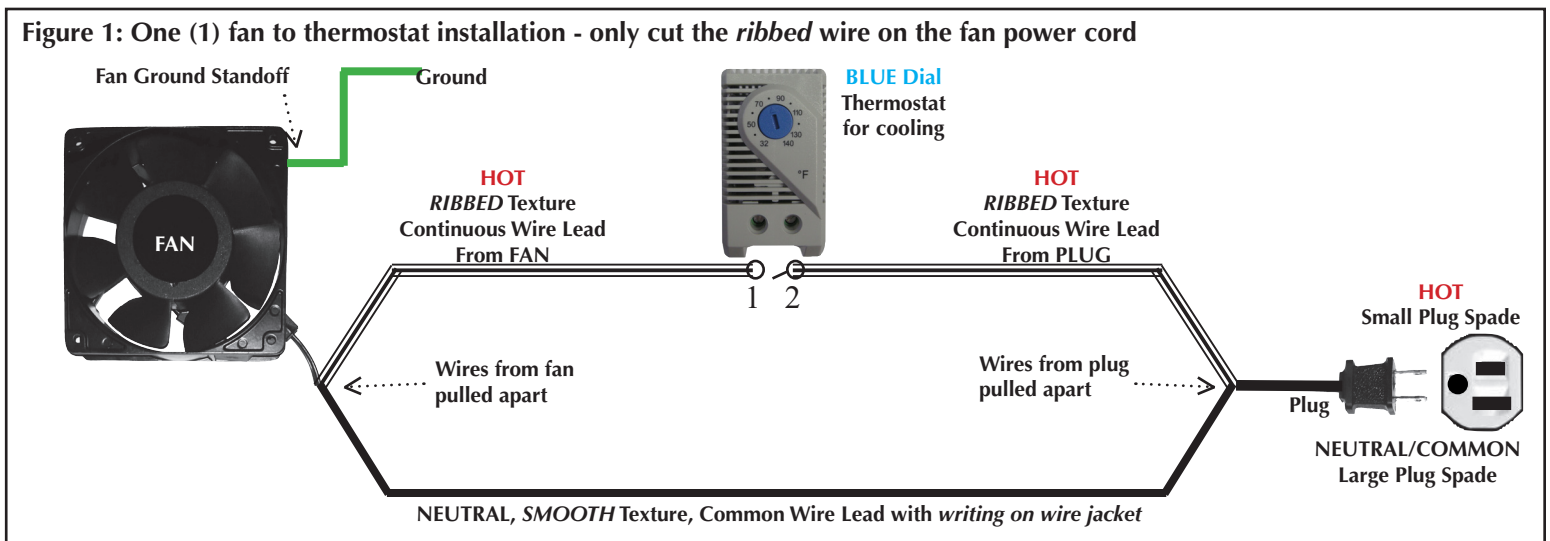

Installation Instructions

Connecting TWO Fans To The Thermostat

- 1-2. Set the Thermostat Control 70 to 75 degrees F for most installations. However, before determining the Thermostat setting for your specific application: you must consider the operating parameters of the equipment you are installing, specifically the operating temperatures, and take into consideration the temperature of the installation environment, seasonal changes, and the heat load of the electronics within. If the electronics are less than 100 Watts, and the installation is in a normal indoor temperature controlled setting, it is recommended to set the Thermostat to 80 degrees F
- 2-2. *If only using one fan go to the previous page. For models with two (2) fans, one should blow in and one should blow out if the enclosure only has two openings with shrouds, or both should flow in if the enclosure has four openings.* The fans are marked with an arrow that looks like a numeral 1 showing airflow direction **1**. You need to cut both fan power cords in half. Pull the **Neutral/Smooth/Common Wires** and **Hot/Ribbed/Continuous Wires** apart from each other on both Fan Cords.
- 3-2. Wire the two (2) **Hot/Ribbed/Continuous Wires** from the Fans into **Terminal 1 of the Thermostat**, and the one (1) **Hot/Ribbed/Continuous Wire** from the Plug into **Terminal 2 of the Thermostat** (see Figure 2 below). This wires the Thermostat in series with the two Fans. Connect the two (2) **Neutral/Smooth/Common Wires** from the fans together with the one (1) **Neutral/Smooth/Common Wire** from the Plug, using a wire nut (**Figure 2**). Discard the unused plug.
- 4-2. Mount the Thermostat **INSIDE** the enclosure using the two-sided-tape supplied by placing it on one side of the enclosure. Another method is to mount an optional DIN Rail in the enclosure, and use the DIN Rail tabs on the back of the Thermostat.
- 5-2. Grounding: attach the fan(s) to one of the threaded standoffs in the back of the enclosure with a ground wire(s). Ground standoffs on the fans are clearly marked with an arrow that looks like a numeral 1 showing airflow direction **1**.
- 6-2. Plug the cord into 110/115VAC outlet paying attention to polarity.

Figure 2: Two (2) fans to thermostat installation - cut both the wires on both fan power cords

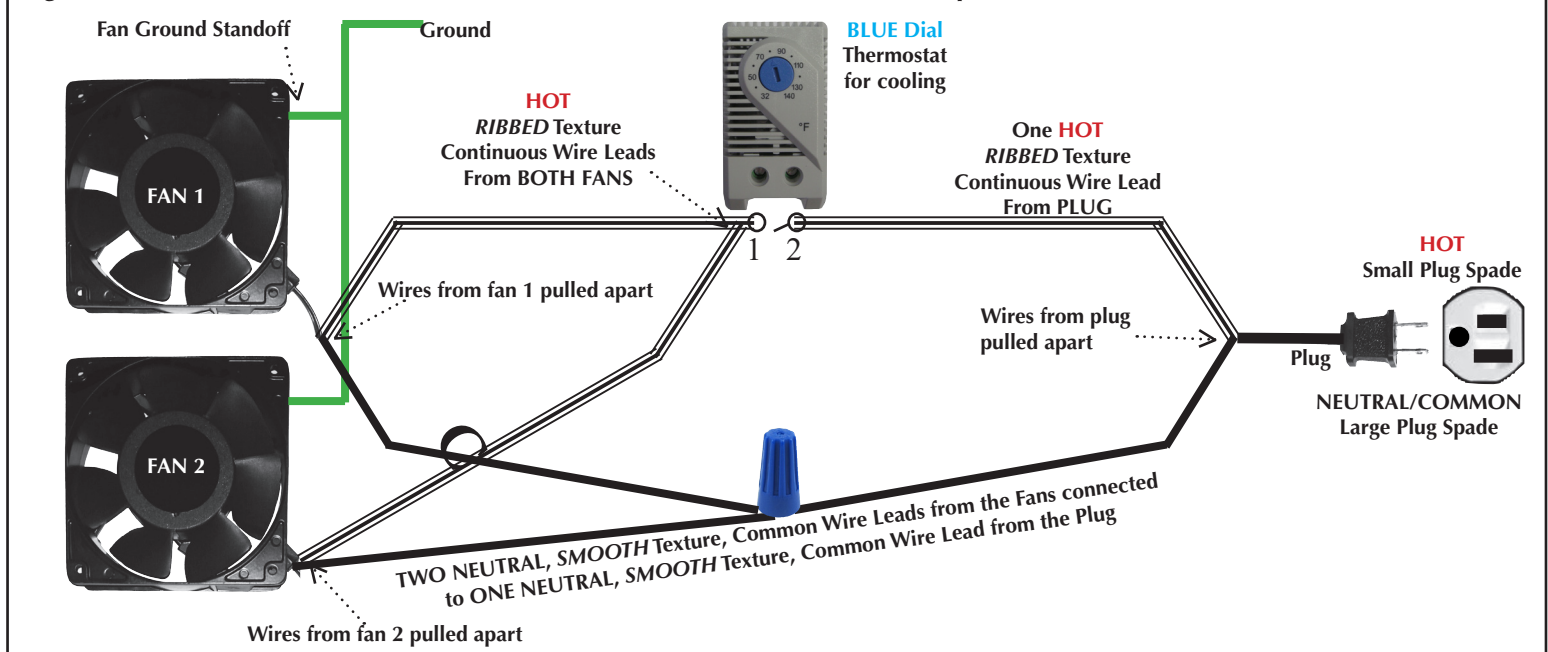

Installation Instructions

Warranty, Technical Support and Shipping Carton Contents

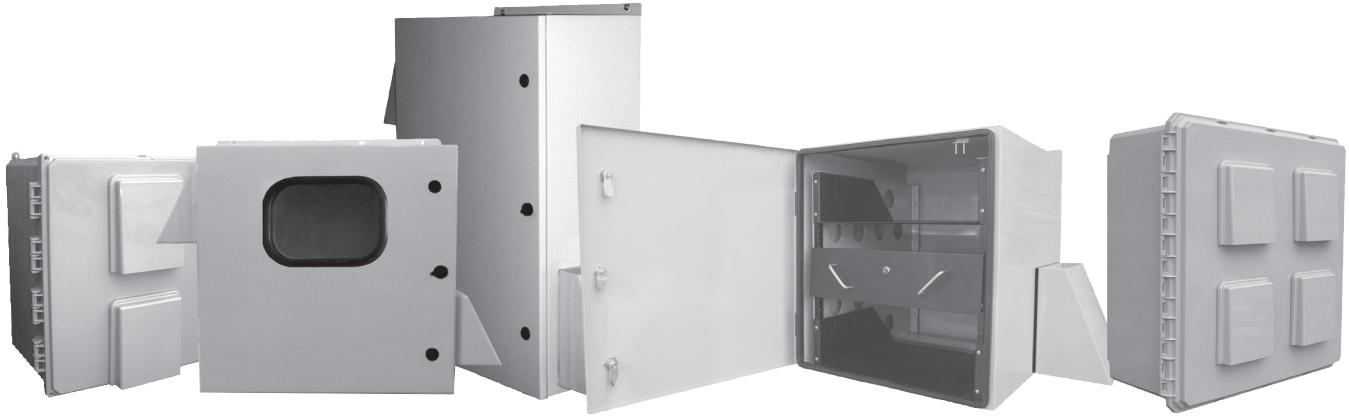

NOTE: These "FC" fan-cooled units simply exchange internal air for the external air. Therefore, Fan-Cooled models are not recommended for high-temperature or low temperature environments. Because these units pull external air into the enclosure through a filtering system, they do not meet the NEMA 4 standards of Mier's air-conditioned and heated models (ACE or ACHT). However, they are designed to NEMA 3R specifications. Therefore, Fan-Cooled models are not recommended for applications where internal components need to be protected from wash down conditions. When using these models you must keep the filters clean and must not block the fan, air intake, or air-flow with items mounted inside the enclosure.

If your installation is using non-hardened electronics in warmer or cooler or humid temperatures, if your equipment creates high internal heat loads, or if you are installing in a coastal or highly corrosive area call Mier Products for advice on our other models. Mier recommends only installing units with windows or clear doors in shaded areas; as interior temperatures of these units reach 20° higher than units without windows or clear doors.

See the Warranty & Return Policy shipped with this enclosure. Warranty protection and information for each component such as fans, filters, and thermostats are provided by their respective OEMs.

- This enclosure is properly installed when the top and bottom mounting ears are flush against the wall or pole-mount kit, and held securely with appropriate bolts, and the hinges face to the left side after the enclosure has been mounted
- Watertight fittings must be used on all openings.
- The door-gasket around the opening of the enclosure must remain in place and never be removed or altered.
- The fans and shrouds must be mounted using the appropriate pre-cut holes on the enclosure, and strictly following OEM installation guidelines.
- If you have ANY questions regarding the installation of these products, call Mier Products at 1-800-473-0213

Your Fans have been placed in a carton and stored inside the enclosure for shipment to protect them. Please CAREFULLY remove them along with the Shrouds, Filters and Hardware and place them aside for installation.

If you have any questions please call Mier Products at 1-800-473-0213 between 8am and 5pm EST.



1-800-473-0213 | infor@mierproducts.com | www.mierproducts.com



Wireless Vehicle Detection | Driveway Alarms | Drive-Up Window Detection | Buried Sensor Systems | Instrument Boxes | DVR/CPU Lockboxes
NEMA Enclosures | Outdoor Enclosures | Temperature Controlled Enclosures | UL/NEMA Non-Metal Enclosures | Rack Enclosures, Shelves,
and Drawers | Siren/Speaker Cabinets | Bell Boxes | Structured-Wiring Flush-Mount Cabinets | Power Supply Boxes | Battery Cabinets
Transformer Covers | Custom Fabrication, Powder Coat, and Graphic Screening



Mounting Examples for Mier Products' TEMPERATURE CONTROLLED ENCLOSURES

Mounted inside the gate-house at a gated community



Along a gate using metal tubing to run wiring from one enclosure to another



Wall-mount



Rack Enclosure mounted on a wall



Using metal tubing or angle-iron and a concrete slab



Installer made mounting surface



Using metal tubing and angle-iron



Pole-Mount Kits available for our enclosures to be mounted on 4" to 14" poles. Call us and specify the enclosure you want to use, and the pole size, for help choosing the correct pole-mount kit.



NOTE: Do Not Mount On Apartment/Condo/Office Walls
Home and office AC units are mounted a few feet away from a home or on the roof of an office building in order to avoid vibration noise from becoming a nuisance to those who live/work within. For that same reason, Mier recommends installers mount our temperature-controlled enclosures on concrete slabs with angle-iron or poles as pictured, or on walls that are not common to living or office space.

- Our engineers recommend the following options around **RGS fittings** in holes installers might cut into the enclosures, in order to keep NEMA ratings:
- If not using conduit or flex-cable, and running your cords directly into the enclosure, we recommend drilling your holes in the bottom of the enclosure and using a Heyco fitting appropriate for your specific cord size, and able to fit in our 3/16" enclosure wall thickness. These fittings can be found at: http://www.heyco.com/Liquid_Tight_Cordgrips/index.cfm
 - If you are using conduit or flex-cable, we recommend drilling your holes in the bottom of the enclosure and using an appropriate fitting such as:
 - SealCon DS21AA-BK = 3/4" Liquid-Tight Conduit Fitting with DOUBLE Lock - <http://www.sealconusa.com/conduit/product/double-seal.html>
 - SealCon ST21NA-BK = 3/4" Liquid-Tight Conduit Fitting with SINGLE Lock - <http://www.sealconusa.com/conduit/product/condsttwist-npt.html>
 - McMaster Carr 7119K13 = 3/4" Liquid-Tight Conduit Fitting/Heavy-Duty - <http://www.mcmaster.com/#7119k13/=vg864m>



Back Panels for 24" x 24" and 24" x 36" Enclosures

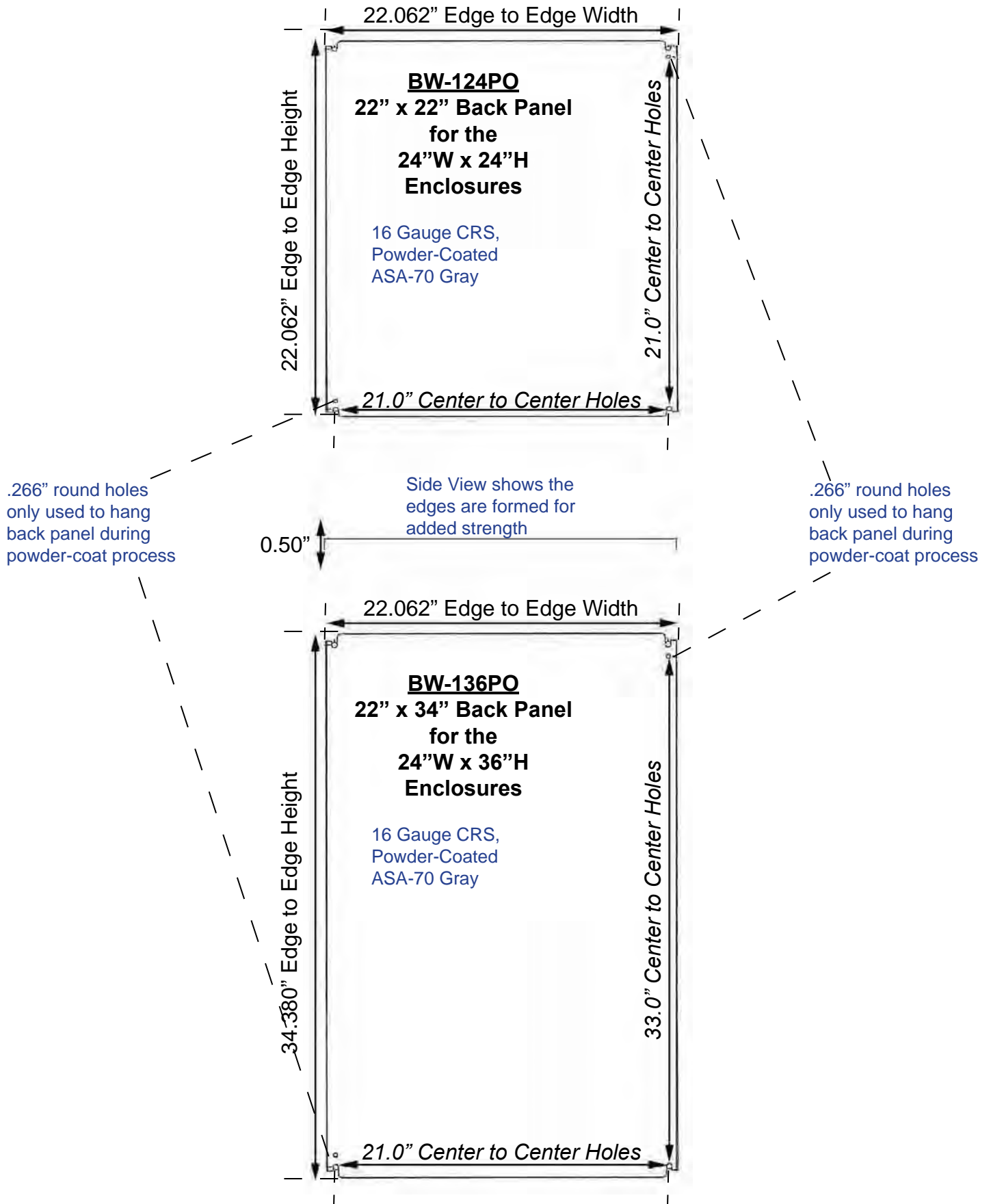

Dimensions and Weight

- Outside dimensions *without* Shrouds attached: 24.8"W x 26.5"H x 8.8"D
- Outside dimensions *with* Shrouds attached are: 35.3"W x 26.5"H x 8.8"D
- Inside dimensions are: 23.9"W x 23.9"H x 7.9"D
- Internal back panel dimensions: 22"x22"
- Enclosure with back panel weighs 54 lbs
- Shrouds (2) weigh and additional 5.2 lbs
- Shipping skid weighs 50 lbs

External 0.580" mounting hole dimensions are: 20" center-to-center from left to right and 25 3/8" center-to-center from top to bottom

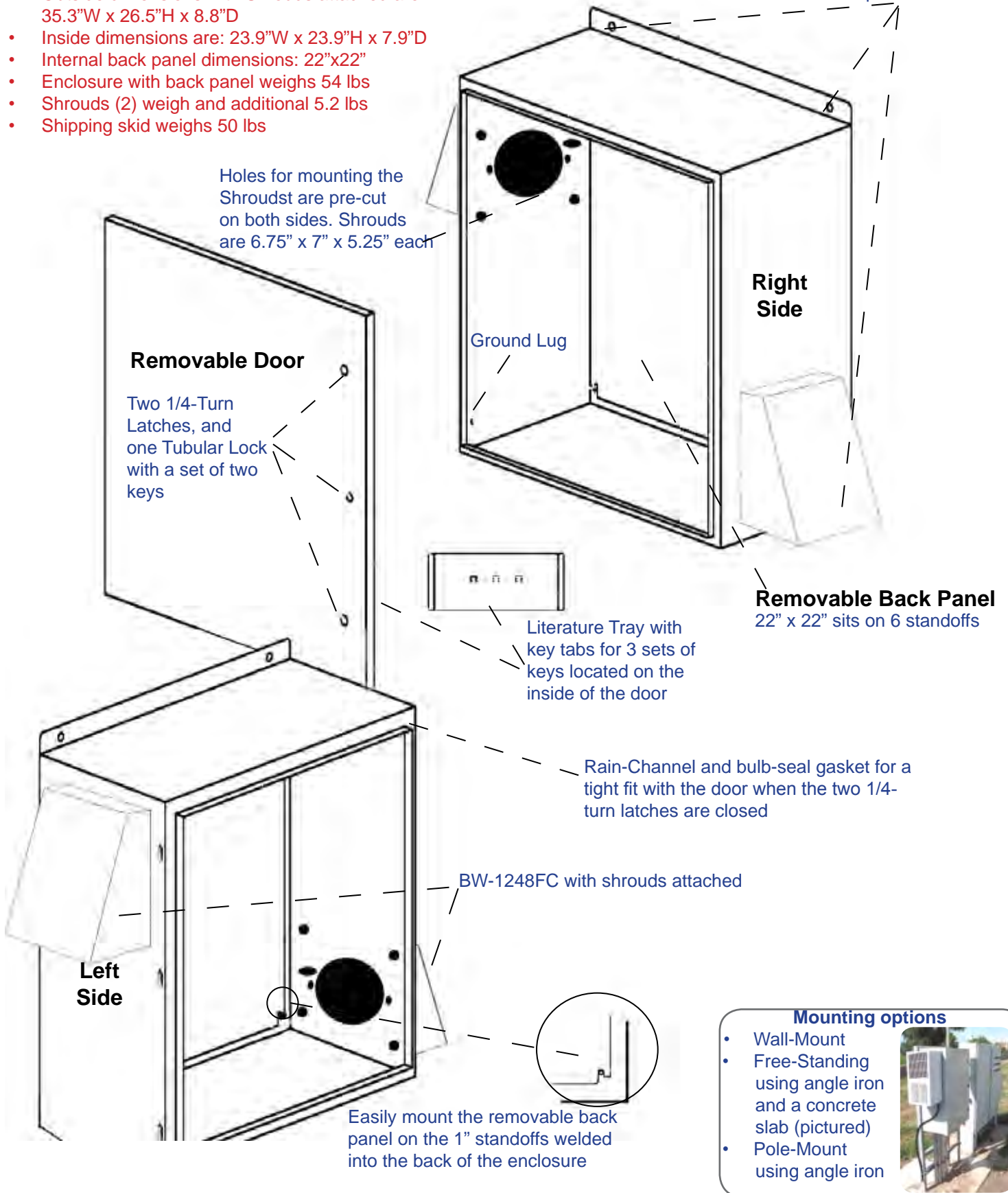

Dimensions and Weight

- Outside dimensions *without* Shrouds attached: 24.8"W x 26.5"H x 12.8"D
- Outside dimensions *with* Shrouds attached are: 39.8"W x 26.5"H x 12.8"D
- Inside dimensions are: 23.9"W x 23.9"H x 11.9"D
- Internal back panel dimensions: 22"x22"
- Enclosure with back panel weighs 60 lbs
- Shrouds (2) weigh and additional 11.5 lbs
- Shipping skid weighs 50 lbs

External 0.580" mounting hole dimensions are:
20" center-to-center from left to right and
25 3/8" center-to-center from top to bottom

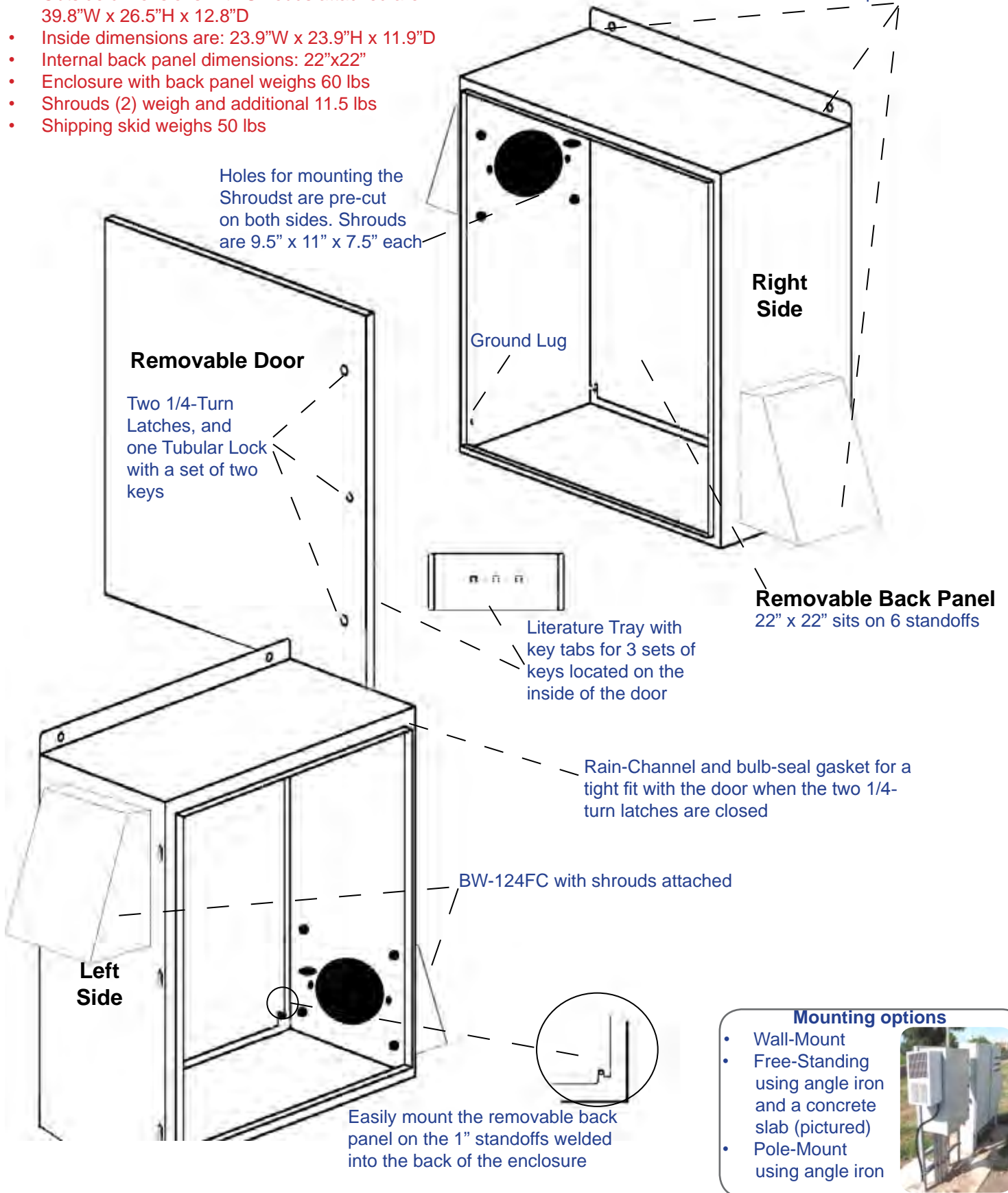

Dimensions and Weight

- Outside dimensions *without* Shrouds attached: 24.8"W x 38.5"H x 12.8"D
- Outside dimensions *with* Shrouds attached are: 39.8"W x 38.5"H x 12.8"D
- Inside dimensions are: 23.9"W x 35.9"H x 11.9"D
- Internal back panel dimensions: 22"x34"
- Enclosure with back panel weighs 70 lbs
- Shrouds (2) weigh and additional 11.5 lbs
- Shipping skid weighs 50 lbs

External 0.580" mounting hole dimensions are:
20" center-to-center from left to right and
37 3/8" center-to-center from top to bottom

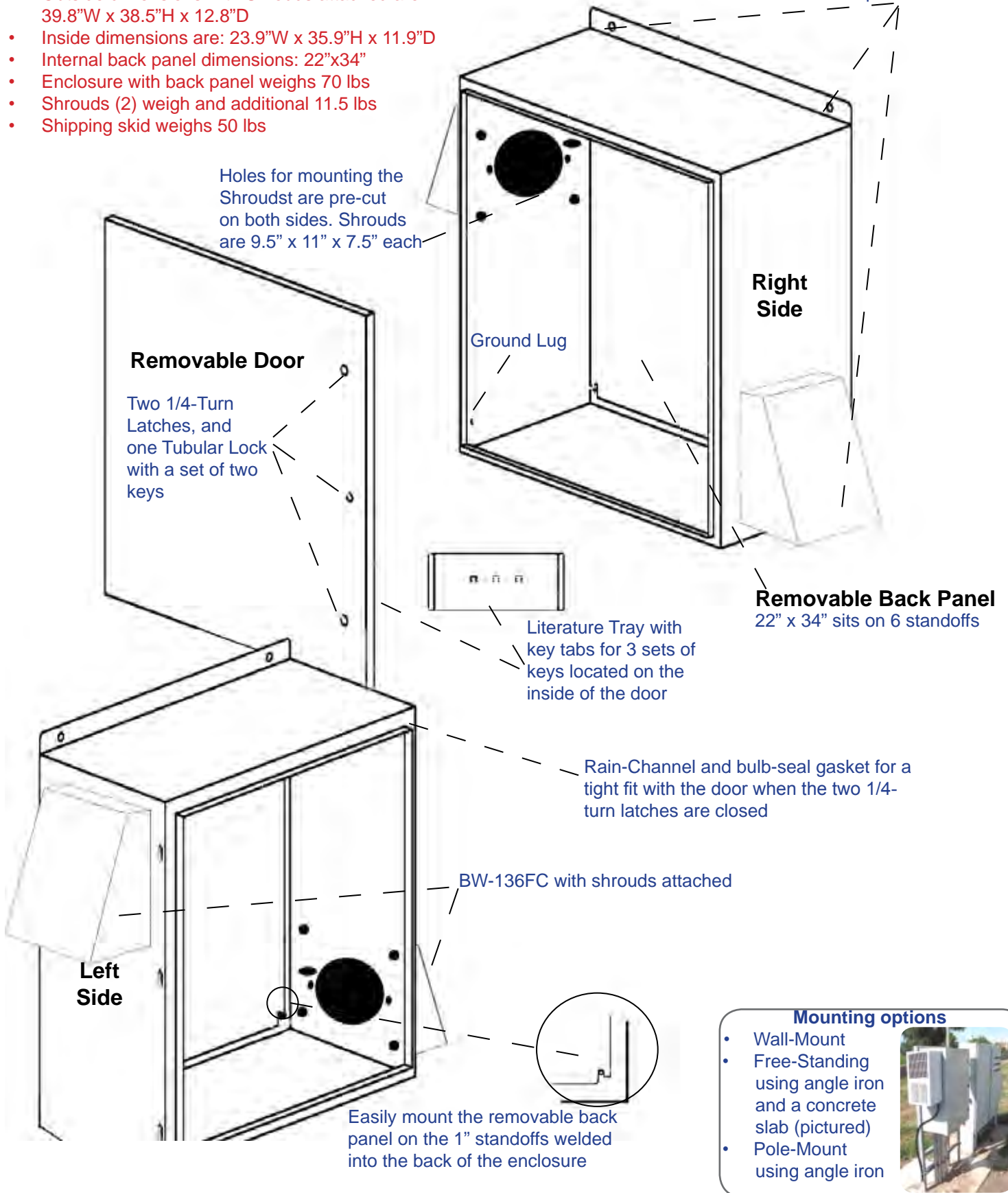

BW-RACKFC

Dimensions and Weight

- Outside dimensions *without* Shrouds: 22"W x 24"H x 24"D
- Outside dimensions *with* Shrouds: 37"W x 24"H x 24"D
- Inside dimensions are: 21.5"W x 23.7"H x 23.8"D
However, the standard 19" 12RU Rack makes the workable rack space 19"W x 21"H x 22"D plus another 1.5" in front of the rack
- Enclosure weighs 105 lbs
- Shrouds weigh 6 lbs each (12 lbs total)
- Shipping skid weighs 50 lbs

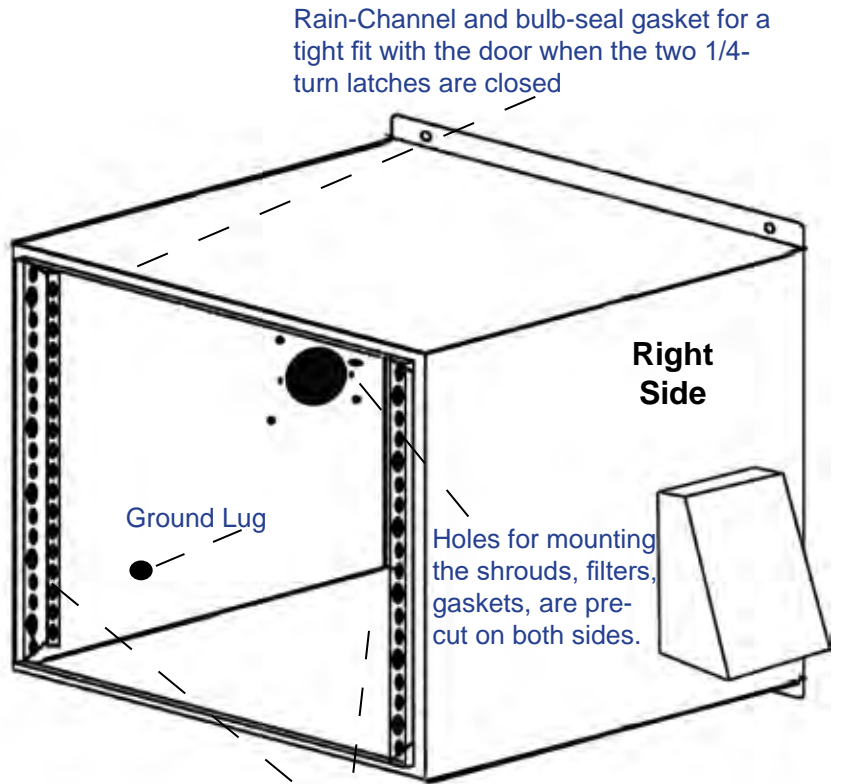
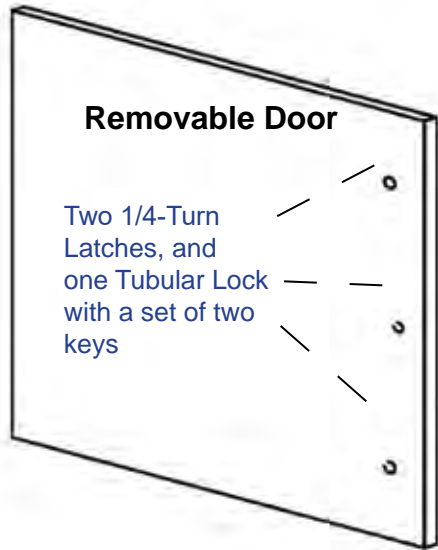

12 RU Rack-Rails

NOTE: The distance from rails to the back of the enclosure is 23 inches deep. However, there are tabs that protrude in on both the rear-left and rear-right which the rack mounts to, so it is 22" on the extreme left and extreme right.

BW-RACKFC with Shrouds attached.

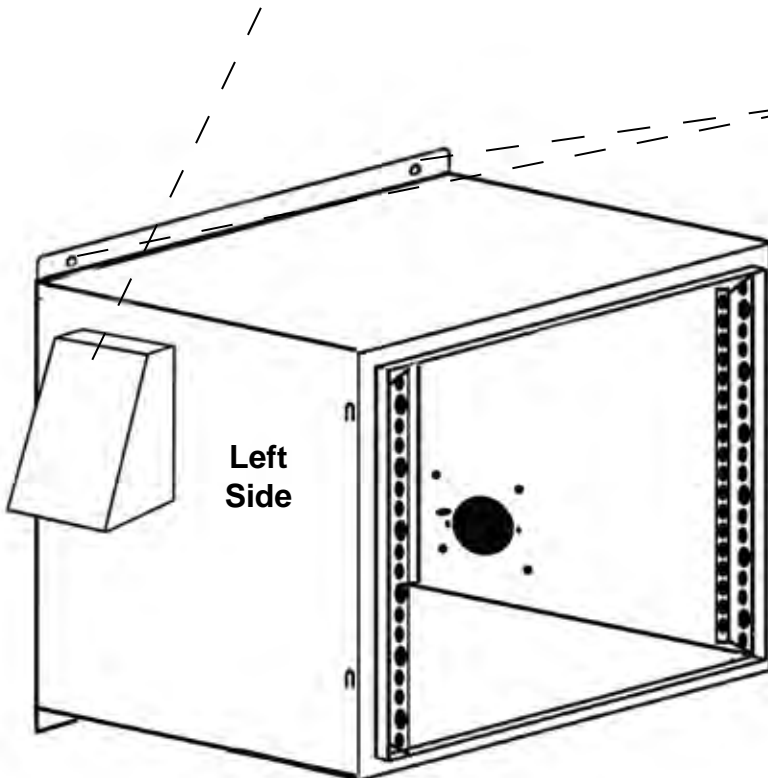

External 0.580" mounting hole dimensions are: 20" center-to-center from left to right and 25 3/8" center-to-center from top to bottom

Mounting options

- Wall-Mount
- Free-Standing using angle-iron or pole-iron and a concrete slab (pictured)
- Pole-Mount using angle iron



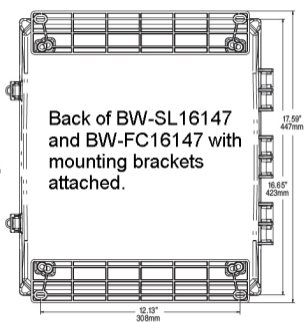
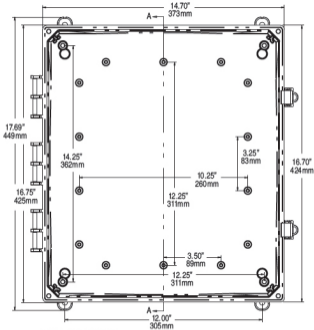

Back of BW-SL16147
and BW-FC16147 with
mounting brackets
attached.

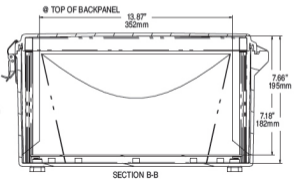
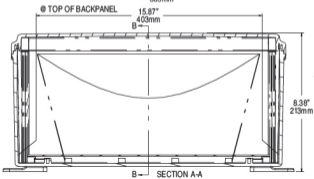

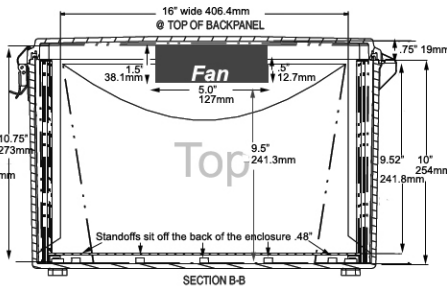
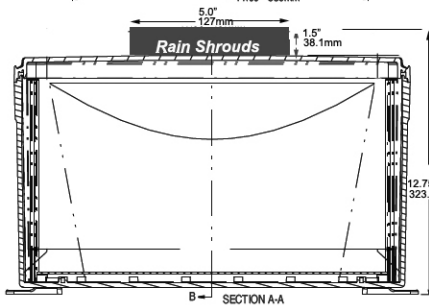
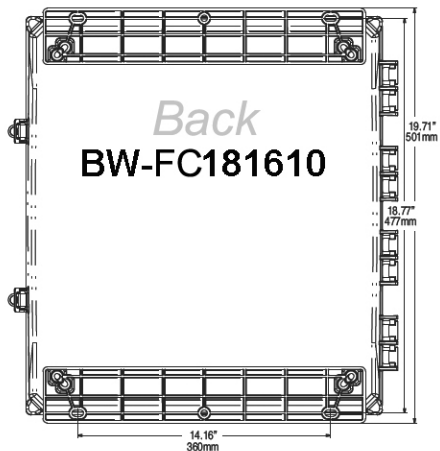
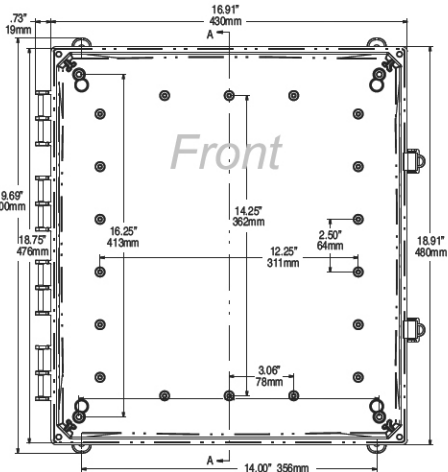

BW-FC242410 - 24" x 24" x 10" polycarbonate, NEMA 3R, fan ventilated enclosure includes four shrouds, four gaskets, and two fans installed in the door.

Hinged Side

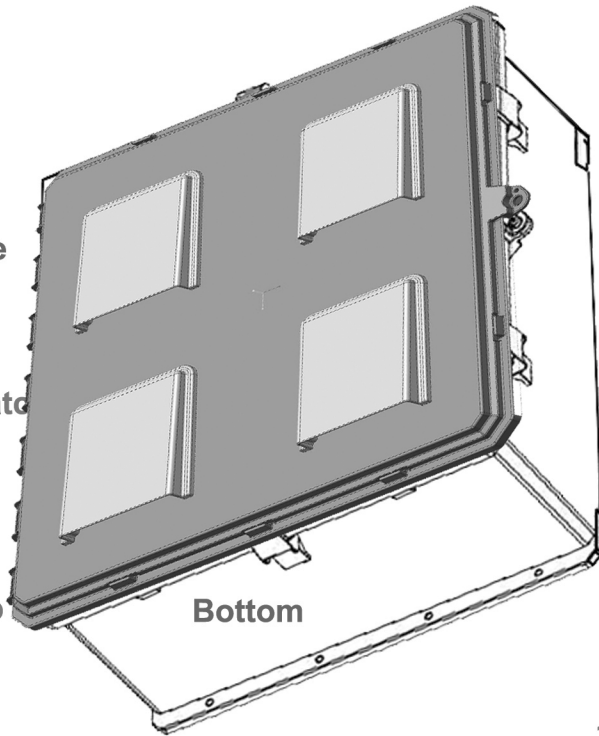

Latching side includes a pad-lock latch, and optional snap-latches which can be placed in several locations. This drawing shows two on this side one on top, and one on bottom.

Exterior:
27.8" Wide including hinge & latch
27.2" High including latches
11.5" Deep including mounting brackets

Interior:
24" Wide x 24" High x 10" Deep

Bottom

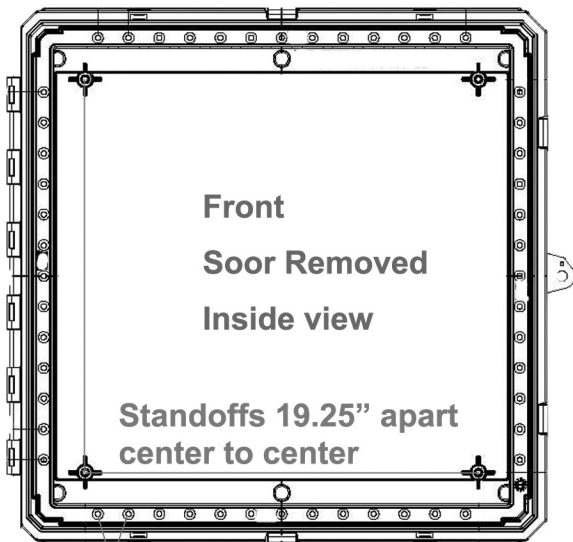
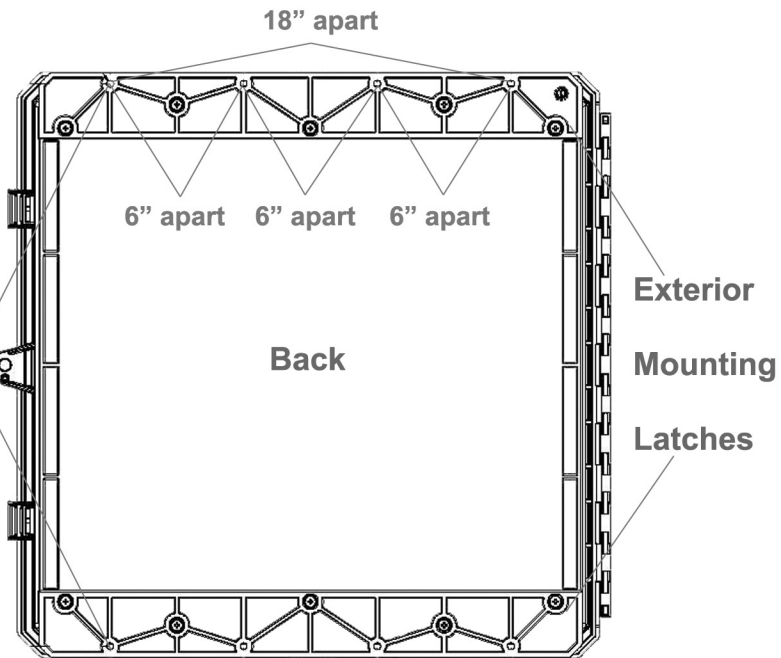
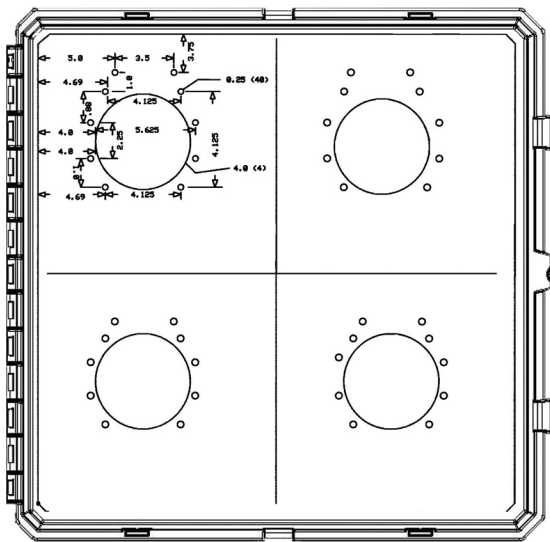

Front
Door Removed
Inside view

Standoffs 19.25" apart
center to center

1.5" apart

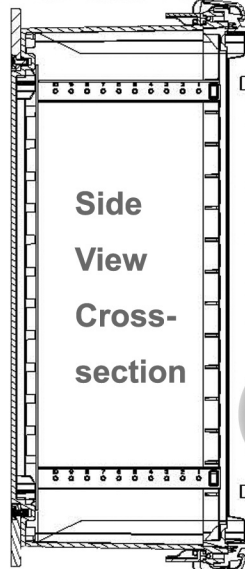

Side
View
Cross-
section

Mier
PRODUCTS, INC.

800-473-0213

info@mierproducts.com