



## Fence & Railing

EMS carries an extensive line of Mechanical Railing, Welded Railing (including Dixie Caps), Pipe & Wall Brackets, and Glass Railing. We also carry Square Tube for Posts and Pickets (Standards page 17), Castings as well as Anchoring Cement.

**Mechanical Fence & Railing** .....pages 01-03  
**Welded Railing** .....pages 04-06  
**Dixie Cap Railing** .....pages 07  
**Railing Channel** .....page 08  
**Pipe & Wall Brackets** .....page 09  
**Glass Railing** .....pages 10-17  
**Castings** ..... Castings pages 01-04



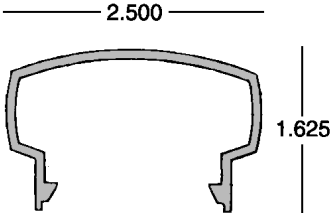
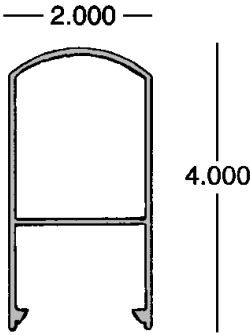
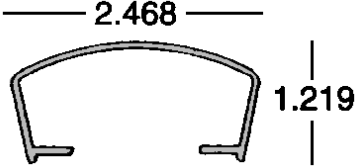
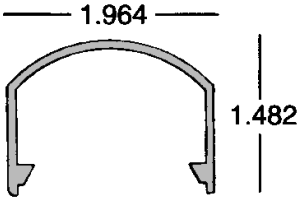
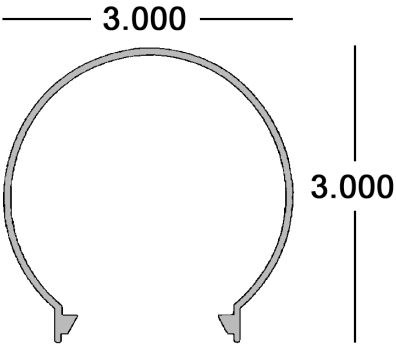

## Mechanical Fence & Railing

<p><b>Top Cap - HR-1</b>  <b>HR-1-WH</b> White x 20'  <b>HR-1-BR</b> Bronze x 20'  <b>HR-1-BR (MO)</b> MO Bronze x 20'  <b>HR-1-MF (MO)</b> Mill Finish x 20'  <b>HR-1-TB (MO)</b> Textured Black x 20'  <b>52-63-5578</b> Black x 25'  <i>mates with HR-2, HR-2C; 8 pc sub-bundles</i></p>  <p><b>Accepts Castings:</b>            End Cap #75: <a href="#">21-00-100</a>            Wall Mount #56: <a href="#">21-00-187</a></p>	<p><b>Top Cap - HR-8</b>  <b>HR-8-WH</b> White x 20'  <b>HR-8-BR</b> Bronze x 20'  <i>mates with HR-2, HR-2C; 4 pc sub-bundles</i></p>  <p><b>Accepts Castings:</b>            End Cap #96: <a href="#">21-00-131</a>            Wall Mount #63: <a href="#">21-00-063</a></p>	<p><b>Top Cap - HR-10</b>  <b>HR-10-WH</b> White x 20'  <b>HR-10-BR</b> Bronze x 20'  <b>HR-10-BK</b> Black x 20'  <i>All mate with HR-11A; 6 pc sub-bundles</i></p>  <p><b>Accepts Castings:</b>            End Cap #34: <a href="#">21-00-105</a>            Flat End Cap #34F: <a href="#">52-00-147</a>            Wall Mount #13: <a href="#">21-00-186</a></p>
<p><b>Top Cap - HR-14</b>  <b>HR-14-WH</b> White x 20'  <b>HR-14-BR</b> Bronze x 20'  <b>HR-14-BK</b> Black x 20'  <i>mates with HR-2, HR-2C; 8 pc sub-bundles</i></p>  <p><b>Accepts Castings:</b>            End Cap #188: <a href="#">21-00-114</a>            Wall Mount #62: <a href="#">21-00-155</a></p>	<p><b>Top Cap - HR-17</b>  <b>MILL ORDER HR-17-WH</b>  <i>mates with HR-2, HR-2C; 6 pc sub-bundles</i></p> 	

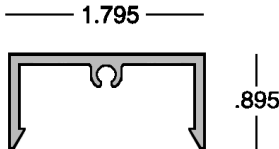
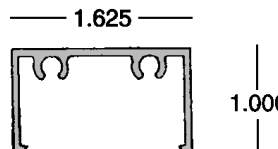
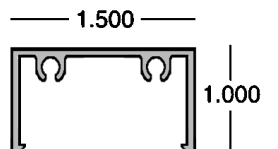
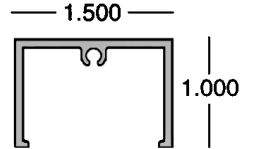
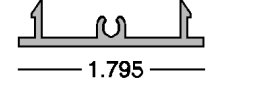
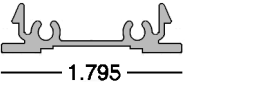
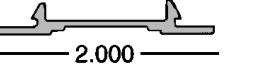

RAILING & FENCE 01

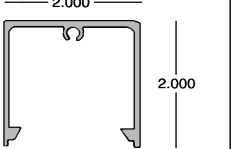
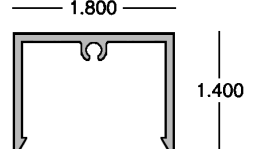
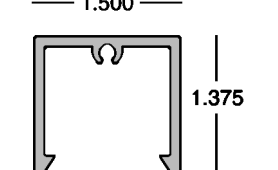

<p><b>Bottom Channel - HR-3</b>  <b>HR-3-WH</b> White x 19' 6"  <b>HR-3-BR</b> Bronze x 19' 6"  <b>HR-3-BR (MO)</b> MO Bronze x 19' 6"  <b>HR-3-BK</b> Black x 19' 6"  <b>HR-3-TB (MO)</b> Textured Black x 19' 6"  <b>HR-3-MF (MO)</b> Mill Finish x 19' 6"  <i>All mate with HR-2; 8 pc sub-bundles</i></p>  <p><b>Accepts Casting:</b>  Wall Mount #54: 21-00-316</p>	<p><b>Snap Channel - HR-12</b>  <b>HR-12-WH</b> White x 19' 6"  <b>HR-12-BR</b> Bronze x 19' 6"  <b>HR-12-BK</b> Black x 19' 6"  <i>12 pc sub-bundles</i></p>  <p><b>Accepts Casting:</b>  Wall Mount #39: 21-00-185</p>	<p><b>Bottom Channel - HR-12A</b>  <b>HR-12A-WH</b> White x 19' 6"  <b>HR-12A-BR</b> Bronze x 19' 6"  <i>12 pc sub-bundles</i></p>  <p><b>Accepts Casting:</b>  Wall Mount #68: 21-00-183</p>
<p><b>Bottom Channel - HR-12B</b>  <b>HR-12B-WH</b> White x 19' 6"  <b>HR-12B-BR</b> Bronze x 19' 6"  <b>HR-12B-BK</b> Black x 19' 6"  <i>12 pc sub-bundles</i></p>  <p><b>Accepts Casting:</b>  Wall Mount #68: 21-00-183</p>	<p><b>Snap Plate - HR-2</b>  <b>52-63-6147</b> White x 19' 6" (FL)  <b>52-63-6149</b> Bronze x 19' 6" (FL)  <b>HR-2-MF (MO)</b> Mill Finish x 20'  <b>HR-2-WH</b> White x 21' 1"  <b>HR-2-BR</b> Bronze x 21' 1"  <b>HR-2-BR (MO)</b> MO Bronze x 21' 1"  <b>HR-2-BK</b> Black x 21' 1"  <b>HR-2-TB (MO)</b> Textured Black x 21' 1"  <b>HR-2-WH-2</b> White x 23'  <b>HR-2-BR-2</b> Bronze x 23'  <b>HR-2-BK-2</b> Black x 23'  <i>All mate with HR-1, 3, 4, 4A, 4C, 6, 7, 8, 14</i>  <i>12 pc sub-bundles</i></p> 	<p><b>Snap Plate - HR-2C</b>  <b>HR-2C-WH</b> White x 20'  <b>HR-2C-BR</b> Bronze x 20'  <b>HR-2C-BK</b> Black x 20'  <i>All mate with HR-1, HR-3, HR-8, HR-14, HR-17; All use Pickets HR-5 and HR-13</i>  <i>10 pc sub-bundles</i></p> 
<p><b>Snap Plate - HR-11A</b>  <b>HR-11A-WH</b> White x 20'  <b>HR-11A-BR</b> Bronze x 20'  <b>HR-11A-BK</b> Black x 20'  <i>All mate with HR-10; All use Pickets HR-5 and HR-13; 12 pc sub-bundles</i></p> 	<p><b>Snap Plate - HR-15</b>  <b>HR-15-WH-1</b> White x 18' 6"  <i>mates with HR-16; 16 pc sub-bundles</i></p> 	<p><b>Snap Post - HR-4</b>  <b>52-63-6146</b> White x 19' 6"  <b>52-63-6148</b> Bronze x 19' 6"  <b>HR-4-WH</b> White x 21' 1"  <b>HR-4-BR</b> Bronze x 21' 1"  <b>HR-4-BK</b> Black x 21' 1"  <b>HR-4-WH-2</b> White x 23'  <b>HR-4-BR-2</b> Bronze x 23'  <b>HR-4-BK-2</b> Black x 23'  <i>mates with HR-2</i>  <i>6 pc sub-bundles</i></p>  <p><b>Accepts Casting:</b>  Floor Flange #40: 21-00-210</p>
<p><b>Snap Post - HR-4A</b>  <b>HR-4A-WH</b> White x 21' 1"  <b>HR-4A-BR</b> Bronze x 21' 1"  <b>HR-4A-BR (MO)</b> MO Bronze x 21' 1"  <b>HR-4A-TB (MO)</b> Textured Black x 21' 1"  <b>HR-4A-BK</b> Black x 25'  <i>mates with HR-2; 6 pc sub-bundles</i></p>  <p><b>Accepts Casting:</b>  Floor Flange #50: 21-00-195  Floor Flange #50HD 21-00-196</p>	<p><b>Snap Post - HR-16</b>  <b>HR-16-WH-1</b> White x 18' 6"  <i>mates with HR-15; 8 pc sub-bundles</i></p>  <p><b>Accepts Casting:</b>  Floor Flange #42: 21-00-309</p>	

**RAILING & FENCE 02**

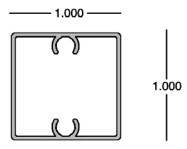
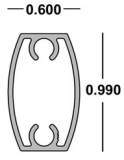
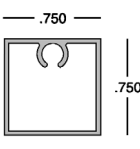
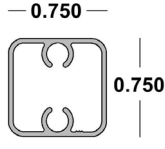

<p><b>1" Picket - HR-5</b>  <b>200-WH-075</b> White x 19'10"  <b>200-MB-075</b> Bronze x 19'10"  <b>HR-5-WH</b> White x 23'  <b>HR-5-BR</b> Bronze x 23'  <b>HR-5-BK</b> Black x 23' 6"  <b>HR-5-TB</b> (MO) Textured Black x 23'  <b>HR-5-MF</b> (TX) Mill Finish x 23'  20 pc sub-bundles</p> 	<p><b>1" Oval Picket</b>  <b>MILL ORDER - 52-63-12344</b></p> 	<p><b>3/4" Picket - HR-13</b>  <b>HR-13-WH-1</b> White x 19' 1"  <b>HR-13-BR-1</b> Bronze x 19' 1"  <b>HR-13-BK</b> Black x 19' 1"  <b>HR-13-WH</b> White x 22' 5"  <b>HR-13-BR</b> Bronze x 22' 5"  20 pc sub-bundles</p> 	<p><b>3/4" Picket w/radius</b>  <b>HR-13R (.120 Radius)</b>  <b>HR-13R-WH20</b> White x 20'  <b>HR-13R-BR20</b> Bronze x 20'  <b>HR-13R-WH (MO)</b> White x 24'  <b>HR-13R-BR (MO)</b> Bronze x 24'  <b>HR-13R-TB (MO)</b> Text Black x 24'  20 pc sub-bundles</p> 	<p><b>3/4" Spears</b>  <b>19-63-105PS1</b> .062 x 58"  <b>19-63-105PS2</b> .062 x 70"</p> <p><b>1" Spears</b>  <b>19-63-130PS1</b> .060 x 58"  <b>19-63-130PS2</b> .060 x 70"</p> 
---	---	--	--	---

## Aluminum Posts & Pickets

### Painted Square Tube - 6063-T6

Stock Code	Size in Inches	Approx. Wt/Lin ft.
19-WH-204	2 x .093 x 24' White	0.851
19-MB-204	2 x .093 x 24' Bronze	0.851
19-BK-204	2 x .093 x 24' Black	0.851
19-IV-300	2 x .125 x 24' Ivory	1.125
19-WH-305	2 x .125 x 24' 6" White	1.125
19-MB-305	2 x .125 x 24' 6" Bronze	1.125
19-BG-305	2 x .125 x 24' 6" Beige	1.125
19-COLOR-212	2 x .250 x 24' **	2.100
19-WH-003	3 x .093 x 24' White	1.298
19-MB-003	3 x .093 x 24' Bronze	1.298
19-63-231TB (MO)	3 x .093 x 24' Textured Black	1.298
200-WH-027	3 x .093 x 30' White	1.298
200-MB-027	3 x .093 x 30' Bronze	1.298
19-WH-225	3 x .125 x 20' White	1.726
19-WH-220	3 x .125 x 24' White	1.726
19-MB-235	3 x .125 x 24' Bronze	1.726
19-IV-235	3 x .125 x 24' Ivory	1.726
19-BG-235	3 x .125 x 24' Beige	1.726
19-BK-235	3 x .125 x 24' Black	1.726
19-COLOR-240	3 x .250 x 24' **	3.300
52-COLOR-4424	3.50 x .125 x 24' **	2.024
19-WH-245	4 x .125 x 20' White	2.325
19-WH-400	4 x .125 x 24' White	2.325
19-MB-246	4 x .125 x 24' Bronze	2.325
19-IV-400	4 x .125 x 24' Ivory	2.325
19-BG-400	4 x .125 x 24' Beige	2.325
19-BK-400	4 x .125 x 24' Black	2.325
200-WH-028	4 x .125 x 30' White	2.325
200-MB-028	4 x .125 x 30' Bronze	2.325
19-WH-2500	4 x .250 x 20' White	4.500
19-MB-2500	4 x .250 x 24' Bronze	4.500
19-IV-2500	4 x .250 x 24' Ivory	4.500
19-BG-2500	4 x .250 x 24' Beige	4.500
19-WH-2501	4 x .250 x 24' 6" White	4.500
<b>3" Scalloped Square Tube</b>		
42-WH-003 (MO)	3" x 20' White	0.757
200-WH-017	3" x 24' White	0.757
200-MB-017	3" x 24' Bronze	0.757
200-WH-018	3" x 30' White	0.757
200-MB-018	3" x 30' Bronze	0.757

\*\*COLOR - Available in White (WH), Bronze (MB), Ivory (IV), and Beige (BG)

## Aluminum Woven Wire Mesh - NEW!

Alloy 1350 - H16

ID Size	Stock Code	Size in Inches	Approx. Wt/Sheet
2.00 ID	50-2X2WM-4896	.236 x 48 x 96	17.60
2.00 ID	50-2X2WM-48120	.236 x 48 x 120	21.78
<b>1.75" ID; 2.25" OD</b> Alloy 1350 - H16 - <b>CLOSEOUT!</b>			
50-WWM-4896	(MO)	.236 x 48 x 96	20.60



### Woven Wire Mesh Framing Options

see *Stiffeners, Enclosures & Gates 11* for schematic

13-63-205	1/2 x 3/4 x 1/8 Channel x 20' (6063-T52)
60-00-205	MP-1A (1 x 1 x 24')
59-63-002 (TX)	MP-1A (1 x 1 x 24')

<p><b>Hard-Rok</b>  <b>61-00-007</b> 5 Gallon Bucket  Contains no gypsum or chlorides;  Quick setting anchoring cement;</p> 	<p><b>Quik Rok</b>  <b>61-00-001</b> 5 Gallon Bucket  <b>Anchoring Cement</b>  <b>NEVER</b> to be used to anchor balcony railing or any similar human life safety structures</p> 
---	--

<p><b>45° Post x 20'</b> #2  <b>52-63-2033</b> wt/ft: 1.041  <b>Wall: .085/.150</b> 6061-T6</p> 	<p><b>16 oz Touch Up Spray Paint</b></p> <table border="1"> <thead> <tr> <th>Stock Code</th> <th>Color</th> </tr> </thead> <tbody> <tr><td>35-00-100</td><td>White</td></tr> <tr><td>35-00-100G</td><td>White Gloss</td></tr> <tr><td>35-00-105</td><td>Bronze</td></tr> <tr><td>35-00-105G</td><td>Bronze Gloss</td></tr> <tr><td>35-00-110</td><td>Ivory Gloss</td></tr> <tr><td>35-00-115 (TX)</td><td>Beige</td></tr> <tr><td>35-00-115G</td><td>Beige Gloss</td></tr> <tr><td>35-00-120</td><td>Black</td></tr> <tr><td>35-00-120G</td><td>Black Gloss</td></tr> </tbody> </table>	Stock Code	Color	35-00-100	White	35-00-100G	White Gloss	35-00-105	Bronze	35-00-105G	Bronze Gloss	35-00-110	Ivory Gloss	35-00-115 (TX)	Beige	35-00-115G	Beige Gloss	35-00-120	Black	35-00-120G	Black Gloss
Stock Code	Color																				
35-00-100	White																				
35-00-100G	White Gloss																				
35-00-105	Bronze																				
35-00-105G	Bronze Gloss																				
35-00-110	Ivory Gloss																				
35-00-115 (TX)	Beige																				
35-00-115G	Beige Gloss																				
35-00-120	Black																				
35-00-120G	Black Gloss																				







## Welded Railing

**2-5/8" Hollow Cap x 25' 10" - 129**

**28-63-210** wt/ft: 0.573

accepts 3/4" Picket with 2" Post; Mates w/#133

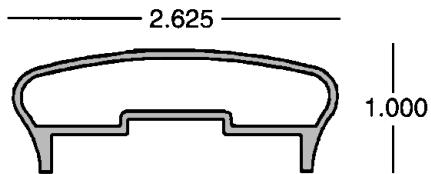

**Accepts Castings:**

End Cap #28: 21-00-135

Wall Mount #52: 21-00-302

**2-5/8" Solid Cap x 25' 10" - 130**

**28-63-200** wt/ft: 0.530

accepts 3/4" Picket w/2" Post; Mates w/#133

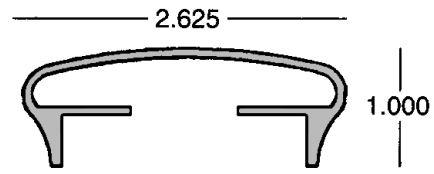

**Accepts Castings:**

End Cap #28: 21-00-135

Wall Mount #52: 21-00-302

**Outside Sleeve x 20' - 133**

**28-63-220** wt/ft: 0.732

mates with #129 and #130

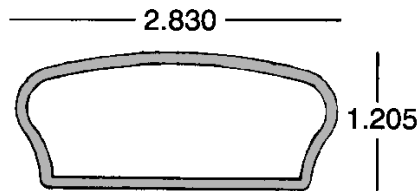

**2" x 1" Hollow Cap x 20' - 131**

**28-63-275** wt/ft: 0.437

accepts 3/4" Picket with 1-1/2" Post

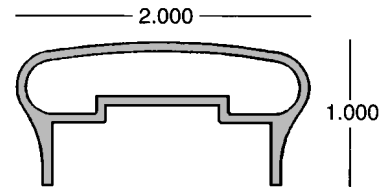

**Accepts Castings:**

End Cap #261: MILL ORDER - 21-00-330

Wall Mount #329: MILL ORDER

**3" Oval Top Cap x 25' - 147**

**28-63-267** wt/ft: 0.635

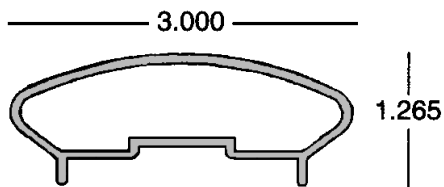

**Accepts Castings:**

Wall Mount: MILL ORDER: 21-00-19

**Outside Sleeve for 3" Oval Top Cap 148**

Mill Order **52-63-8767** wt/ft: 0.941

mates with #147

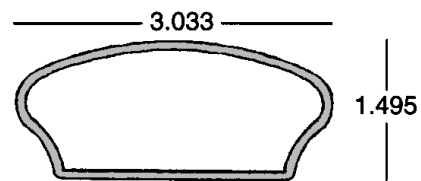

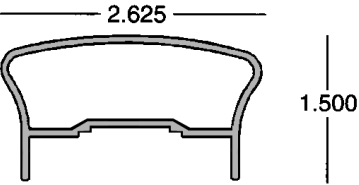
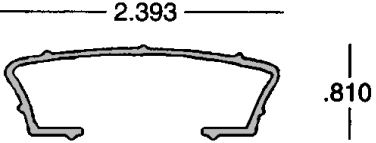
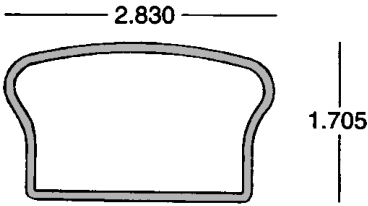
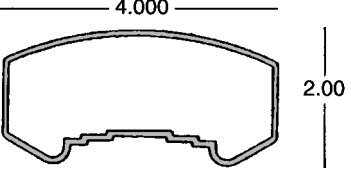
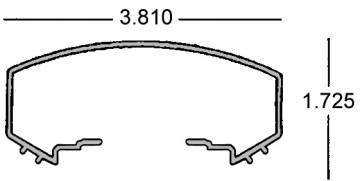
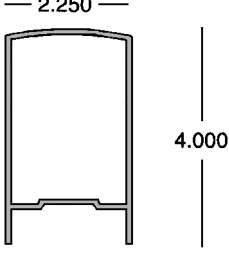
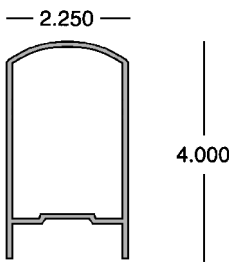
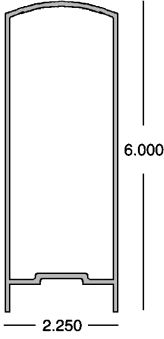
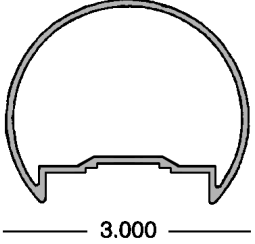
<p><b>2-5/8" Hollow Cap x 25' 10" 135</b>  <b>28-63-215 wt/ft: 0.670</b>  <i>accepts 3/4" and 1" Pickets with 2" Post;</i>  <i>Mates w/ #136 and #137</i></p>  <p><b>Accepts Castings:</b>  End Cap #18: <u>21-00-140</u>, Flat End Cap #18F: <u>21-00-140F</u>; 5052 Flat End Cap: <u>21-5052-140</u>  Wall Mount #271: <u>21-00-160</u></p>	<p><b>2-5/8" Inner Splice x 10' 136</b>  <b>28-63-208 wt/ft: 0.344</b>  <i>mates with #135 (28-63-215)</i></p> 	<p><b>2-5/8" Outside Sleeve x 20' 137</b>  <b>28-63-225 wt/ft: 0.840</b>  <i>mates with #135 (28-63-215)</i></p> 
<p><b>4 x 2 Oval Top Cap x 24' - 152</b>  <b>28-63-285 wt/ft: 1.172</b>  <i>accepts 3/4" Picket ; accepts 1-1/2" and 2" Post</i></p>  <p><b>Accepts Castings:</b>  End Cap #167: MILL ORDER - <u>21-00-313</u>  Wall Mount #680: MILL ORDER - <u>21-00-680</u></p>	<p><b>4 x 2 Inner Splice x 12'</b>  <b><u>52-63-13204</u> wt/ft: 0.655</b>  <i>mates with #152 (28-63-285)</i></p> 	<p><b>Top Cap x 24' - 139</b>  <b>28-63-255 wt/ft: 1.477</b>  <i>(less radius)</i>  <i>accepts 3/4" Picket with 2" Post</i></p>  <p><b>Accepts Castings:</b>  End Cap #14: <u>21-00-146</u>  Wall Mount #24: <u>21-00-165</u></p>
<p><b>Top Cap x 24' - 140</b>  <b>28-63-256 wt/ft: 1.274</b>  <i>(more radius)</i>  <i>accepts 3/4" Picket with 2" Post</i></p>  <p><b>Accepts Castings:</b>  End Cap #70: <u>21-00-145</u>  Wall Mount #190W: <u>21-00-190W</u></p>	<p><b>Top Cap x 24' - 144</b>  <b>MILL ORDER <u>28-63-260</u></b>  <b>wt/ft: 1.740</b>  <i>accepts 3/4" Picket &amp; 2" Post</i></p> 	<p><b>3" Round Top Cap x 24' - 149</b>  <b>28-63-265 wt/ft: 1.001</b>  <i>accepts 3/4" and 1" Pickets &amp; 2" Post; mates with #150 and #151</i></p>  <p><b>Accepts Castings:</b>  End Cap #97 <u>21-00-120</u>, 5052 Flat End Cap: <u>21-5052-120</u>  Wall Mount #185: <u>21-00-1850</u></p>

**RAILING & FENCE 05**



**Inside Sleeve x 10' - 150**  
**40-63-701** wt/ft: 0.718  
*mates with #149*

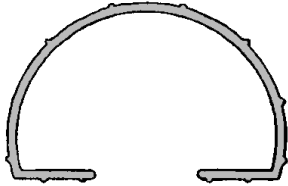

**Outside Sleeve x 10' - 151**  
**28-63-263** wt/ft: 1.042  
*mates with #149*

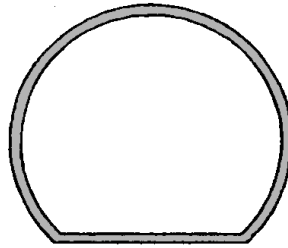

**3" Round Top Cap - Heavy Wall**  
**MILL ORDER - 52-63-12353**  
**wt/ft: 1.489**  
*accepts 3/4" Picket & 2" Post; mates with 52-63-12354*

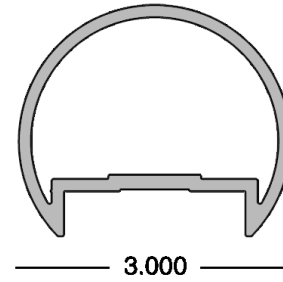

**Accepts Castings:**

End Cap #97 21-00-120, 5052 Flat End Cap: 21-5052-120  
 Wall Mount #185: 21-00-1850

**2-1/2" Colonial Top Rail x 20'**  
**28-63-063 (DE)** wt/ft: 0.600  
**(Wood Style)**  
*Accepts 3/4" Picket*

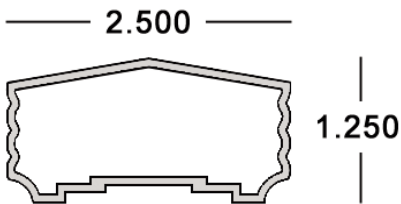

**2-1/4" Colonial Bottom Channel x 20'**  
**28-63-062 (DE)** wt/ft: 0.557  
**(Wood Style)**

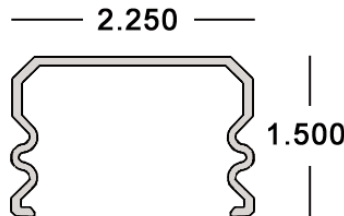

**Inside Sleeve for 3" Round Top Cap**  
**MILL ORDER 52-63-12354** wt/ft: 0.690  
*mates with MILL ORDER 52-63-12353*

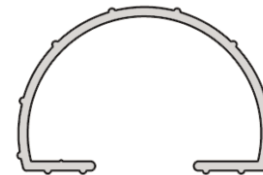

**2" x 1-1/8" Colonial Top Rail**  
**7849-10 (NC)** wt/ft: 0.584  
**(Wood Style)**  
*Accepts 1" Picket*

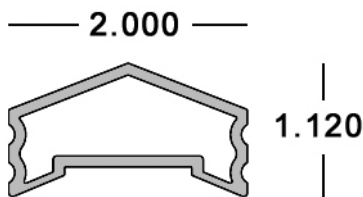

**Handicap Grip Rail x 20' - 132**  
**52-63-1641** wt/ft: 0.665  
*accepts 3/4" Picket with 1-1/4" Post*

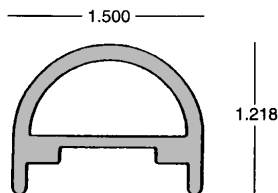

**Accepts Castings:**

End Cap #294 21-00-294

**RAILING & FENCE 06**



# Welded Railing: Dixie Caps



**Dixie Cap x 20' - 154**  
**28-63-100** wt/ft: **0.516**  
 accepts 1" & 1-1/4" Channels

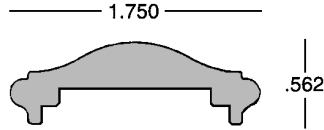

**Dixie Cap x 20'**  
**28-63-103** wt/ft: **0.786**  
 accepts 1" & 1-1/4" Channel

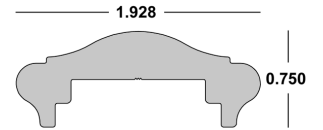

**Dixie Cap x 20' - 158**  
**28-63-230** wt/ft: **1.180**  
 accepts 1-1/4" & 1-1/2" Channels

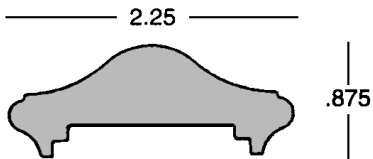

**Dixie Cap x 20' - 155**  
**28-63-105** wt/ft: **0.413**  
 accepts 1-1/2" Channel

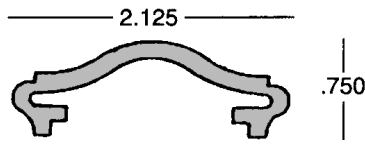

**Dixie Cap x 20' - 156**  
**28-63-110** wt/ft: **0.668**  
 accepts 1", 1-1/4" & 1-1/2" Channel

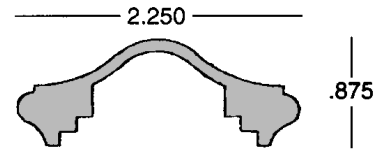

**2-1/4" Dixie Cap x 20'**  
**28-63-111** wt/ft: **0.722**  
 with screw boss; accepts 1-1/2" Channel

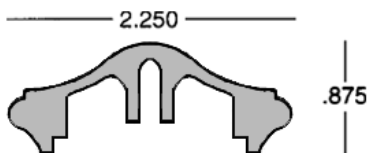

**2-5/8" x 1" Hollow Dixie Cap x 25' 10"**  
**28-63-290** wt/ft: **0.558**  
 accepts 3/4" & 1" Pickets; 2 x 7/16" Channel; 2" Post  
 mates with 28-63-291

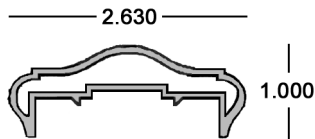

**Accepts Castings:**  
 End Cap #RW-29: [21-00-235](#)  
 Wall Mount #RW-29: [21-00-230](#)

**2-5/8" x 1-1/2" Hollow Dixie Cap x 25' 10"**  
**28-63-295** wt/ft: **0.569**  
 accepts 3/4" & 1" Pickets; 2 x 7/16" Channel; 2" Post; mates with 28-63-296

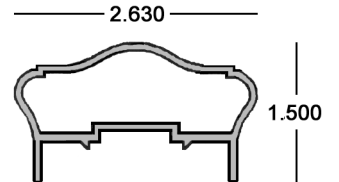

**Accepts Castings:**  
 End Cap #RW-30: [21-00-245](#)  
 Wall Mount #RW-30: [21-00-240](#)

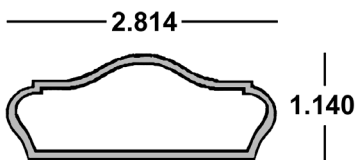

**Outside Sleeve x 20'**  
**28-63-291** wt/ft: **0.500**  
 mates with 28-63-290

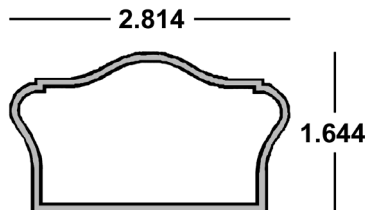

**Outside Sleeve x 20'**  
**28-63-296** wt/ft: **0.571**  
 mates with 28-63-295

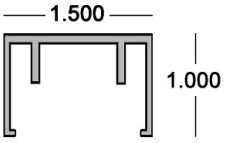
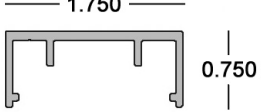
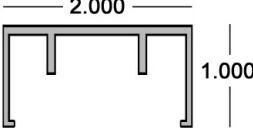
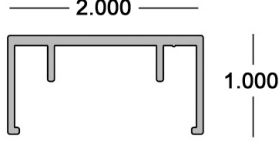
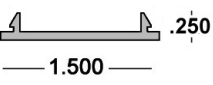
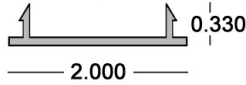

# Railing Channel

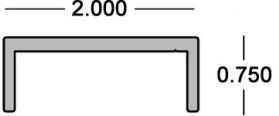
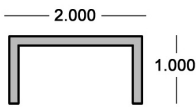
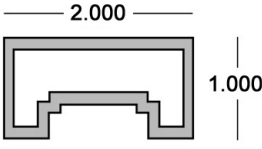
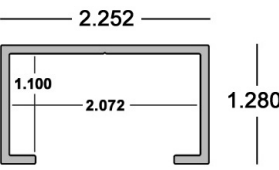
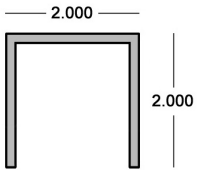
<p><b>1.5 x 1 (.093/.056) Railing Channel x 25'</b> 13-63-300 wt/ft: 0.332 6063-T5 Receives .750 picket; Mates with 13-63-305</p>  <p><b>Accepts Casting:</b> Wall Mount HR-12A #68: 21-00-183</p>	<p><b>1.75 x .75 (.093/.062) Railing Channel x 24'</b> 13-63-264 wt/ft: 0.330 6063-T5 Receives .750 picket;</p> 	<p><b>2 x 1 (.093/.056) Railing Channel x 25'</b> 13-63-266 wt/ft: 0.395 6063-T5 Receives .750 picket; Mates with 13-63-227</p> 	<p><b>2 x 1 (.090/.056) Railing Channel x 25'</b> 13-63-267 wt/ft: 0.395 6063-T5 Receives 1" picket; Mates with 13-63-227</p>  <p><b>Accepts Casting:</b> Wall Mount #15: 21-00-190</p>
<p><b>1.5" Railing Channel Cover Plate x 20'</b> 13-63-305 wt/ft: 0.146 6063-T5 Mates with 13-63-300</p> 	<p><b>2" Railing Channel Cover Plate x 16'</b> 13-63-227 wt/ft: 0.175 6063-T5 Mates with 13-63-266 &amp; 13-63-267</p> 	<p><b>2 x 7/16 x .093 Railing Channel x 25' 2"</b> 13-63-261 wt/ft: 0.294 6063-T5 No Legs</p> 	<p><b>2 x .75 (.125/.093) Railing Channel x 23' 10"</b> 13-63-262 wt/ft: 0.440 6063-T5 No Legs</p> 
<p><b>2 x 1 x .125 Channel x 20'</b> 13-63-265 <b>13-63-274</b> x 24' wt/ft: 0.563 6063-T5</p> 	<p><b>2 x 1 Mid Rail Tube x 24'</b> 52-63-11317 wt/ft: 0.858 6063-T52</p>  <p><b>Accepts Casting:</b> Wall Mount #15: 21-00-190</p>	<p><b>2.252 x 1.280 Outside Sleeve x 12'</b> 52-63-4808 wt/ft: 0.562 6063-T6 Sleeves 2 x 1 Channel and Rectangular Tube</p> 	<p><b>2 x 2 x .125 Channel x 20'</b> 13-63-272 wt/ft: 0.861 6063-T5</p> 

## Pre-Punched Arch Aluminum Railing Channel (Mill Finish 6063-T5)

Stock Code	Size in Inches	Picket
13-63-26620P*	2 x 1 x .093/.056 x 20'	3/4"
13-63-265P	2 x 1 x .125 x 20'	3/4"
13-63-265PR**	2 x 1 x .125 x 24'	3/4"

13-63-26720P*	2 x 1 x .093/.056 x 20'	1"
13-63-274PP	2 x 1 x .125 x 24'	1"

\*with welding legs \*\*for pickets with radius corners

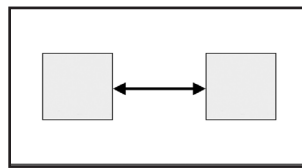

3.75" spacing between holes inside edge to inside edge

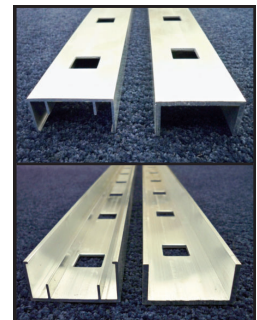

## Picket Spears

19-63-105PS1	3/4 x .062 x 58"
19-63-105PS2	3/4 x .062 x 70"
19-63-130PS1	1 x .060 x 58"
19-63-130PS2	1 x .060 x 70"

3/4" & 1" Spears

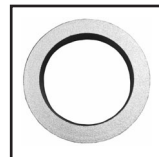
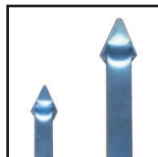

3.75 Decorative Aluminum Rings Casting  
21-00-377

Custom sizes and hole locations available as **SPECIAL ORDER**

Mill Order Items: Not in Stock - Custom Sizes & Lengths Available Minimum Order Required

RAILING & FENCE 08







**Eastern Metal Supply** www.easternmetal.com • info@easternmetal.com 02/04/21  
FL: 800-432-2204 • NC/DE/GA: 800-343-8154 • TX/AR: 800-996-6061 • MO/OH: 888-822-6061

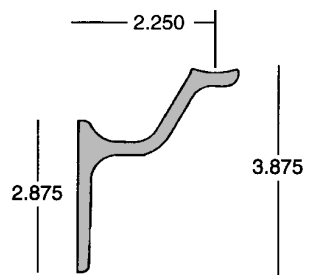
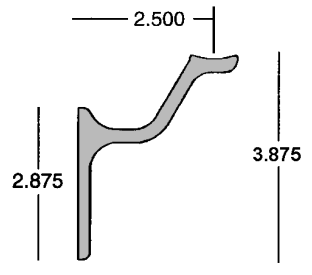

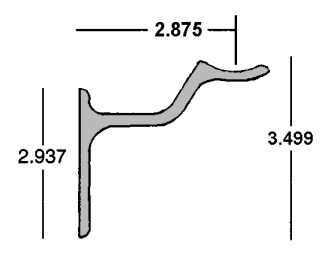
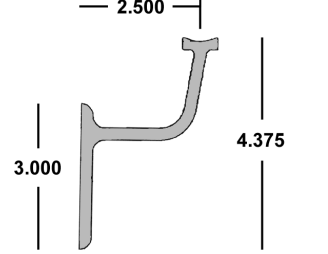
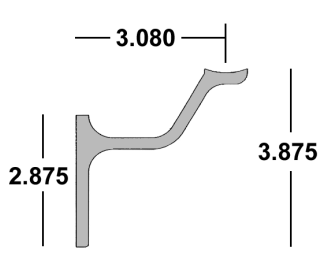
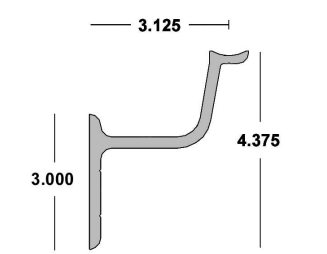
# Pipe Brackets (See Standards 21-22 for full selection of Pipe)

	<p><b>2.25" x 3.875" Centerline Projected Pipe Bracket x 16'</b>                  31-63-135      163                  wt/ft: 1.940</p> 	<p><b>2.50" x 3.875" Centerline Projected Pipe Bracket x 16'</b>                  31-63-120      162                  wt/ft: 2.012</p> 
---	---	--

<p><b>2.875" x 3.50" Centerline Projected Pipe Bracket x 16'</b>                  31-63-105      160                  wt/ft: 1.853</p> 	<p><b>2.50" x 4.375" Centerline Projected Pipe Bracket x 16'</b>                  31-63-140      164                  wt/ft: 2.154</p> 	<p><b>3.080" x 3.875" Centerline Projected Pipe Bracket x 16'</b>                  31-61-145      165                  wt/ft: 2.1815</p> 	<p><b>3.125" x 4.375" Centerline Projected Pipe Bracket x 12'</b>                  31-61-150      wt/ft: 2.264                  Meets NFPA 101 Life Safety Code</p> 
--	--	---	---

<p><b>Grip Rail - NEW!</b>                  Polished &amp; Anodized      Mill Finish</p> <table border="0"> <tr> <td>Stock Code</td> <td>Description</td> <td>Stock Code</td> <td>Description</td> </tr> <tr> <td>GR-12</td> <td>12"</td> <td>GRM-12</td> <td>12"</td> </tr> <tr> <td>GR-14</td> <td>14"</td> <td>GRM-14</td> <td>14"</td> </tr> <tr> <td>GR-18</td> <td>18"</td> <td>GRM-18</td> <td>18"</td> </tr> <tr> <td>GR-24</td> <td>24"</td> <td>GRM-24</td> <td>24"</td> </tr> <tr> <td>GR-36</td> <td>36"</td> <td>GRM-36</td> <td>36"</td> </tr> </table> 	Stock Code	Description	Stock Code	Description	GR-12	12"	GRM-12	12"	GR-14	14"	GRM-14	14"	GR-18	18"	GRM-18	18"	GR-24	24"	GRM-24	24"	GR-36	36"	GRM-36	36"	<p><b>Mark 5 Gate Hinge*</b>                  52-63-8793                  (Heavy Duty)                  with base plate                  *up to 800 lb load</p> 	<p><b>Mark 4 Gate Hinge</b>                  52-63-9150                  (Heavy Duty) without                  base plate</p> 	<p><b>Gate Hinge Bearing</b>                  GATE-BEARING                  1 piece                  For use with Mark 4                  and Mark 5 Gate                  Hinges</p> 
Stock Code	Description	Stock Code	Description																								
GR-12	12"	GRM-12	12"																								
GR-14	14"	GRM-14	14"																								
GR-18	18"	GRM-18	18"																								
GR-24	24"	GRM-24	24"																								
GR-36	36"	GRM-36	36"																								

<p><b>SCH 40 Aluminum Pipe End Caps</b></p> <table border="0"> <tr> <th>Mill Finish</th> <th>Pipe Size</th> </tr> <tr> <td>APC-100-MF</td> <td>1</td> </tr> <tr> <td>APC-125-MF</td> <td>1-1/4</td> </tr> <tr> <td>APC-150-MF</td> <td>1-1/2</td> </tr> <tr> <td>APC-200-MF</td> <td>2</td> </tr> <tr> <th>Anodized</th> <td></td> </tr> <tr> <td>APC-750</td> <td>3/4</td> </tr> <tr> <td>APC-100</td> <td>1</td> </tr> <tr> <td>APC-125</td> <td>1-1/4</td> </tr> <tr> <td>APC-150</td> <td>1-1/2</td> </tr> <tr> <td>APC-200</td> <td>2</td> </tr> <tr> <th>Black Plastic</th> <td></td> </tr> <tr> <td>RN1-1/4DBK1</td> <td>1</td> </tr> </table>  	Mill Finish	Pipe Size	APC-100-MF	1	APC-125-MF	1-1/4	APC-150-MF	1-1/2	APC-200-MF	2	Anodized		APC-750	3/4	APC-100	1	APC-125	1-1/4	APC-150	1-1/2	APC-200	2	Black Plastic		RN1-1/4DBK1	1	<p><b>SCH 40 Pipe x 24' - T4 Temper (for bending)</b></p> <table border="0"> <tr> <th>Stock Code</th> <th>Size in Inches</th> </tr> <tr> <td>18-63-231</td> <td>1-1/4 x 1.660 OD x 1.380 ID x .140 Wall</td> </tr> <tr> <td>18-T4-500</td> <td>1-1/2 x 1.900 OD x 1.610 ID x .145 Wall</td> </tr> </table> <p><b>Many other Pipe sizes, Alloys &amp; Temper are Available</b></p> <p><b>Pipe Inserts (6063-T52)</b></p> <table border="0"> <tr> <td>18-63-259</td> <td>1-1/4</td> <td>SCH 40 x 10'</td> </tr> <tr> <td>18-63-260</td> <td>1-1/2</td> <td>SCH 40 x 10'</td> </tr> <tr> <td>51-00-051</td> <td>1-3/8</td> <td>Serrated Tube x 20' (insert for 1-1/4 pipe)</td> </tr> </table> 	Stock Code	Size in Inches	18-63-231	1-1/4 x 1.660 OD x 1.380 ID x .140 Wall	18-T4-500	1-1/2 x 1.900 OD x 1.610 ID x .145 Wall	18-63-259	1-1/4	SCH 40 x 10'	18-63-260	1-1/2	SCH 40 x 10'	51-00-051	1-3/8	Serrated Tube x 20' (insert for 1-1/4 pipe)
Mill Finish	Pipe Size																																									
APC-100-MF	1																																									
APC-125-MF	1-1/4																																									
APC-150-MF	1-1/2																																									
APC-200-MF	2																																									
Anodized																																										
APC-750	3/4																																									
APC-100	1																																									
APC-125	1-1/4																																									
APC-150	1-1/2																																									
APC-200	2																																									
Black Plastic																																										
RN1-1/4DBK1	1																																									
Stock Code	Size in Inches																																									
18-63-231	1-1/4 x 1.660 OD x 1.380 ID x .140 Wall																																									
18-T4-500	1-1/2 x 1.900 OD x 1.610 ID x .145 Wall																																									
18-63-259	1-1/4	SCH 40 x 10'																																								
18-63-260	1-1/2	SCH 40 x 10'																																								
51-00-051	1-3/8	Serrated Tube x 20' (insert for 1-1/4 pipe)																																								

# CENTERLINE GLASS RAILING - NEW!

## 2.5" Post System

Mechanical/Welded Combo  
Accepts 7/16" and 9/16" Glass  
Tested & Engineered System



**NOW OFFERING:  
CARDINAL GLASS!**

For more information:  
[glass@easternmetal.com](mailto:glass@easternmetal.com)

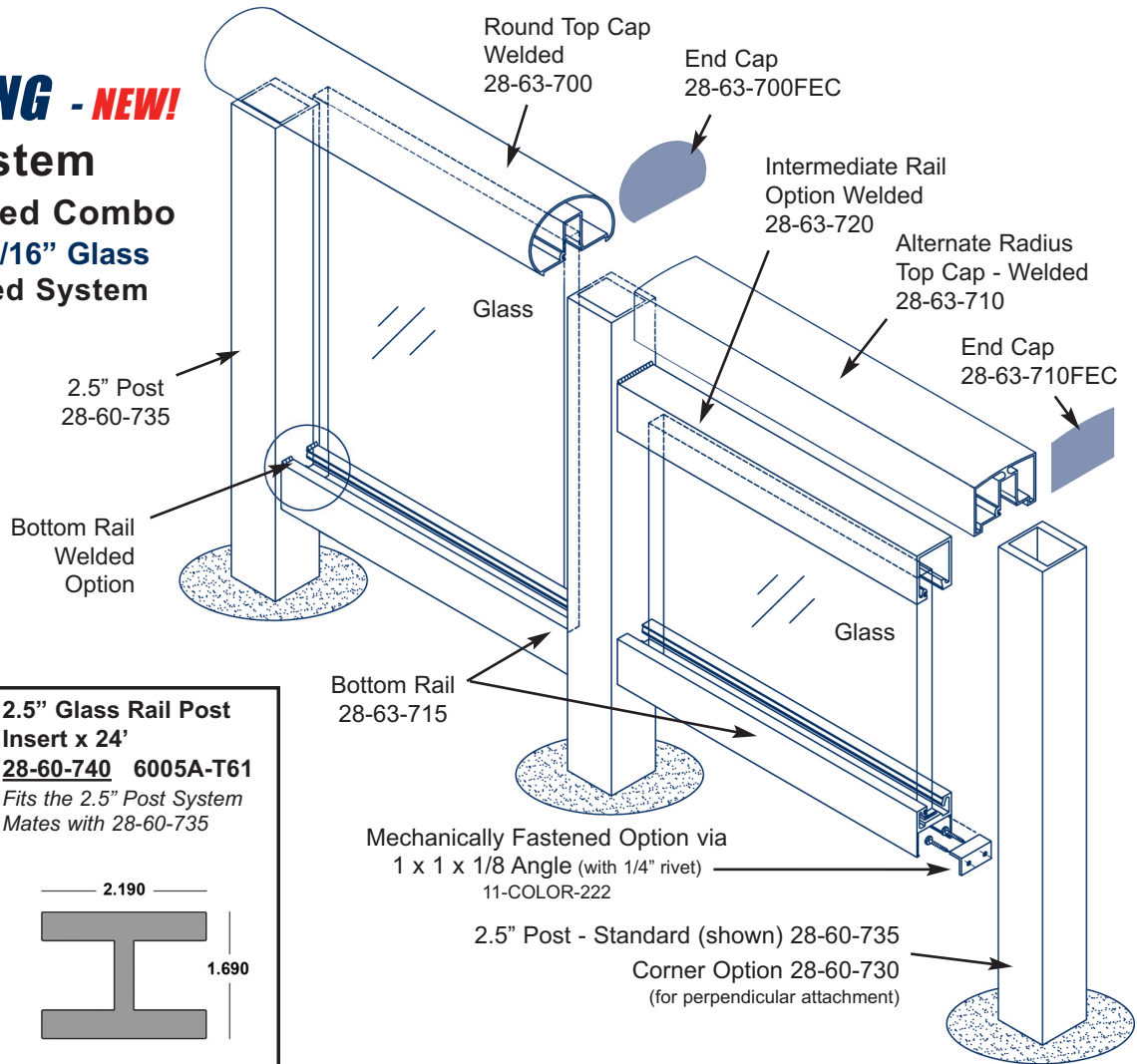

**2.5" Glass Rail Inline Post x 24'**  
**28-60-735** 6005A-T61  
Mates with 28-60-740; Fits the 2.5" Post System

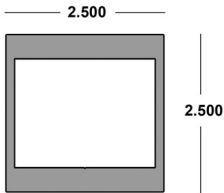

**2.5" Glass Rail Post Insert x 24'**  
**28-60-740** 6005A-T61  
Fits the 2.5" Post System Mates with 28-60-735

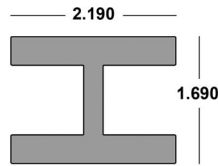

**2.5" Glass Rail Corner Post x 24'**  
**28-60-730** 6005A-T61  
Fit the 2.5" Post System

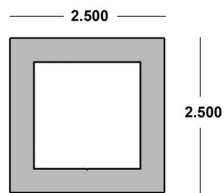

**2.5" x 4.9" Glass Rail 135° Post x 24'**  
**28-60-770** 6005A-T61  
Fits the 2.5" Post System

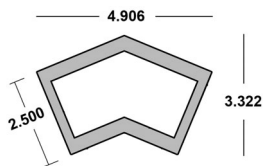

**Alternate Radius Glass Rail Top Cap x 24'**  
**28-63-710** 6063-T6  
Fits the 2.5" Post System  
**28-63-710FEC** End Cap

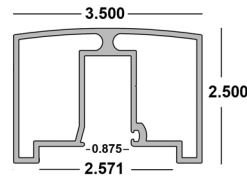

**Top Cap End Caps**  
**28-63-710FEC** End Cap  
Fits **28-63-710**

**28-63-700FEC** End Cap  
Fits **28-63-700**

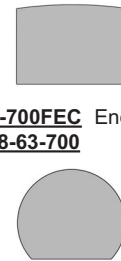

Engineering available by request

**3.5" Round Glass Rail Top Cap x 24'**  
**28-63-700** 6063-T6  
Fits the 2.5" Post System  
**28-63-700FEC** End Cap

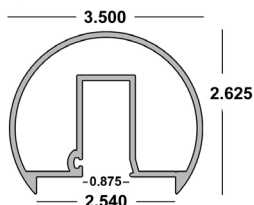

**Round Glass Rail Inner Sleeve x 10'**  
**52-63-8915** 6063-T6  
Fits the 2.5" Post System Mates with 28-63-700

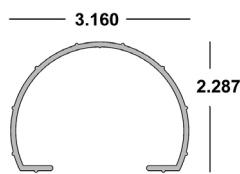

**2" Centerline Glass Rail Bottom Channel x 24'**  
**28-63-715** 6063-T6  
Fits the 2.5" & 3.5" Post Systems; Welded & Mechanical applications; Accepts 1 x 1 x 1/8 Angle 11-COLOR-222; Mates with 52-63-11327

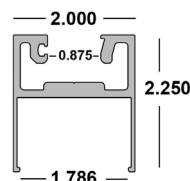

**Cover Plate for Bottom Channel x 16'**  
**52-63-11327** 6063-T6  
Fits the 2.5" & 3.5" Post Systems; Mates with 28-63-715

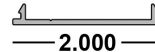

**2" x 2.25" Intermediate Glass Rail x 24'**  
**28-63-720** 6063-T6  
Fits the 2.5" & 3.5" Post Systems

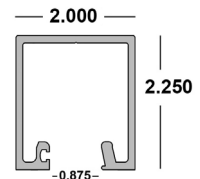

RAILING & FENCE 10



# CENTERLINE GLASS RAILING - NEW!

## 3.5" Post System

Mechanical/Welded Combo  
Accepts 7/16" and 9/16" Glass  
Tested and Engineered System



NOW OFFERING:

**CARDINAL GLASS!**

For more information:

[glass@easternmetal.com](mailto:glass@easternmetal.com)

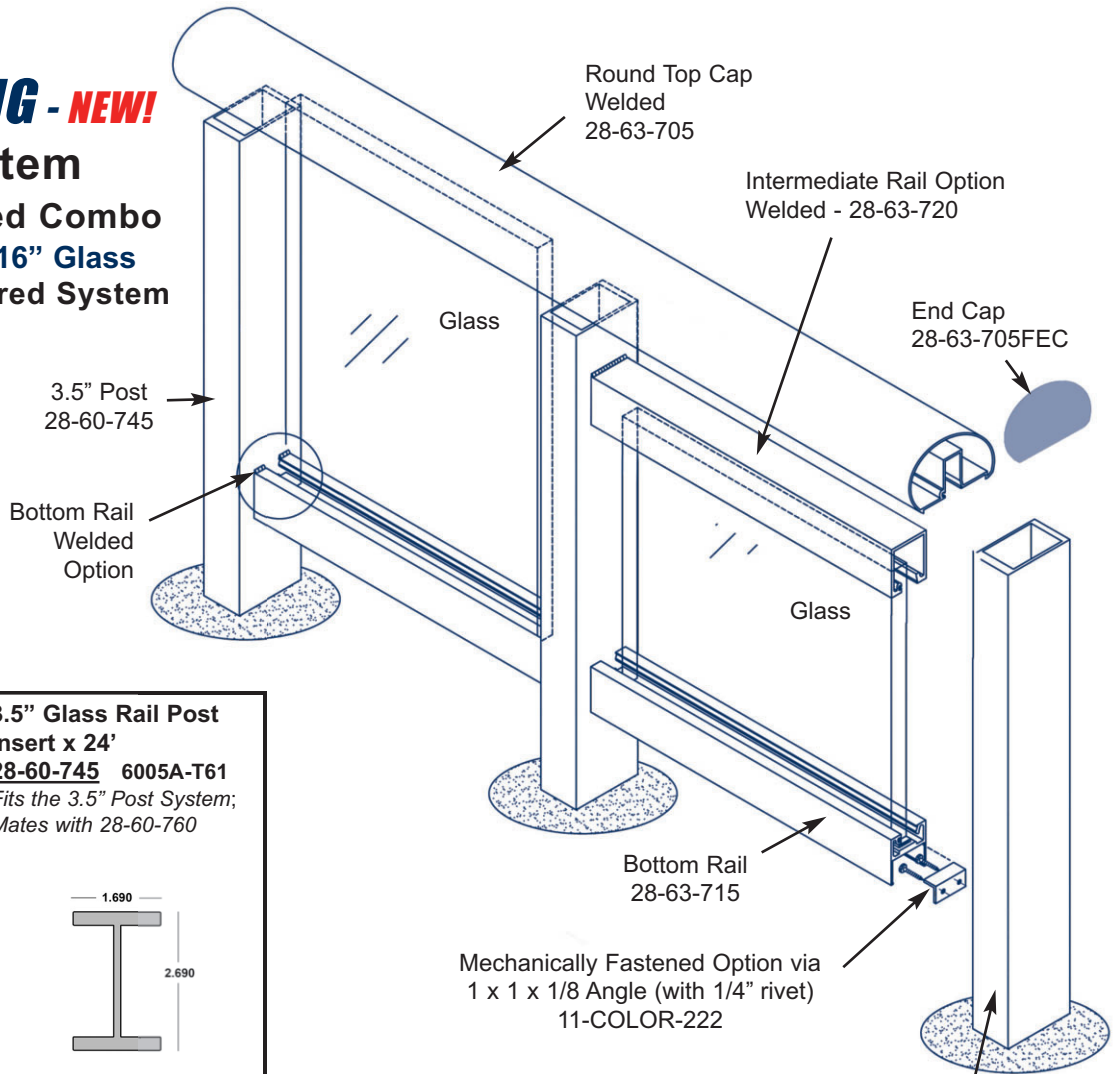

**3.5" x 2" Glass Rail Inline Post x 24'**  
**28-60-760 6005A-T61**  
*Fits the 3.5" Post System; Mates with I-Bar Post Insert 28-60-745*

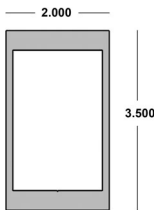

**3.5" Glass Rail Post Insert x 24'**  
**28-60-745 6005A-T61**  
*Fits the 3.5" Post System; Mates with 28-60-760*

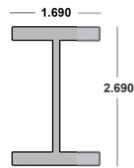

**3.5" x 3.5" Glass Rail Corner Post x 24'**  
**28-60-765 6005A-T61**  
*Fits the 3.5" Post System; Mates with 3" Sq Tube Post Insert 52-61-750*

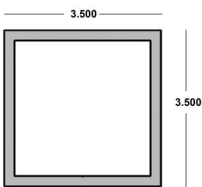

**3" Square Tube Post Insert x 18'**  
**52-61-750 6061-T6**  
*Fits the 3.5" Post System; Mates with 28-60-765*

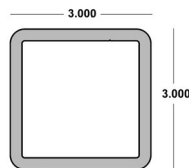

**3.5" x 5.47" Glass Rail 135° Post x 24'**  
**28-60-775 6005A-T61**  
*Fits the 3.5" Post System*

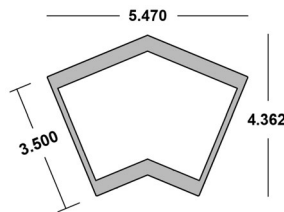

3.5" Post Standard (shown) 28-60-760

Corner Option 28-60-765 (for perpendicular attachment)

Engineering available by request

**4.5" Round Glass Rail Top Cap x 24'**  
**28-63-705 6063-T6**  
*Fits the 3.5" Post System*  
**28-63-705FEC** End Cap

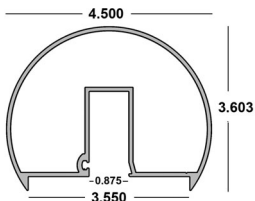

**Top Cap End Cap 28-63-705FEC** End Cap  
Fits **28-63-705**

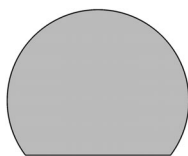

**2" Centerline Glass Rail Bottom Channel x 24'**  
**28-63-715 6063-T6**  
*Fits the 2.5" & 3.5" Post Systems; Welded & Mechanical applications; Accepts 1 x 1 x 1/8 Angle 11-COLOR-222; Mates with 52-63-11327*

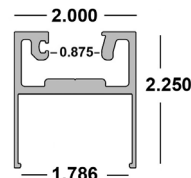

**Cover Plate for Bottom Channel x 16'**  
**52-63-11327 6063-T6**  
*Fits the 2.5" & 3.5" Post Systems; Mates with 28-63-715*

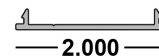

**2" x 2.25" Intermediate Glass Rail x 24'**  
**28-63-720 6063-T6**  
*Fits the 2.5" & 3.5" Post Systems*

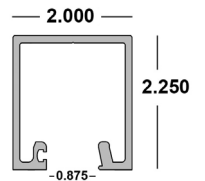

RAILING & FENCE 11



# 60" ROOFTOP CENTERLINE GLASS RAILING - NEW!

**3.5" Post System**  
**Mechanical/Welded Combo**  
 Accepts 7/16" and 9/16" Glass  
 Tested and Engineered System



**NOW OFFERING:**

**CARDINAL GLASS!**

For more information:  
[glass@easternmetal.com](mailto:glass@easternmetal.com)

*\*See engineering for post insert concrete embedment depth*

3" Post Insert  
 52-61-750  
 30" Minimum Height\*

3.5" Post  
 28-60-765

Round Top Cap  
 Welded  
 28-63-705

End Cap  
 28-63-705FEC

3" Post Inserts  
 52-61-750  
 30" Minimum Height\*

Glass

Glass

Bottom Rail  
 28-63-715

Mechanically Fastened via  
 1 x 1 x 1/8 Angle (with 1/4" rivet)  
 11-COLOR-222

*Engineering available by request*

3.5" Post  
 28-60-765

**3.5" x 3.5" Glass Rail Corner Post x 24'**  
**28-60-765 6005A-T61**  
*Fits the 3.5" Post System; Mates with 52-61-750*

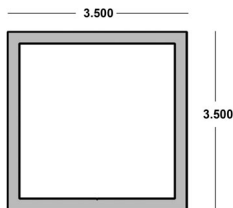

**3" Square Tube Post Insert x 18'**  
**52-61-750 6061-T6**  
*Fits the 3.5" Post System; Mates with 28-60-765*

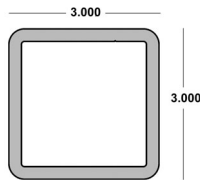

**4.5" Round Glass Rail Top Cap x 24'**  
**28-63-705 6063-T6**  
*Fits the 3.5" Post System*  
**28-63-705FEC End Cap**

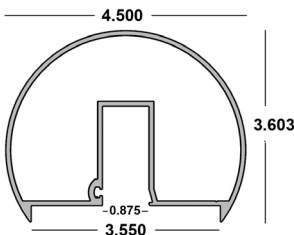

**Top Cap End Cap 28-63-705FEC End Cap**  
*Fits 28-63-705*

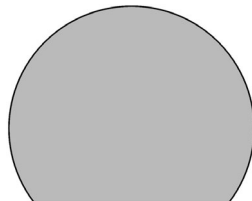

**2" Centerline Glass Rail Bottom Channel x 24'**  
**28-63-715 6005A-T61**  
*Fits the 2.5" & 3.5" Post Systems; Accepts 1 x 1 x 1/8 Angle 11-COLOR-222; Mates with 52-63-11327; Mechanical Application Only for 60" System*

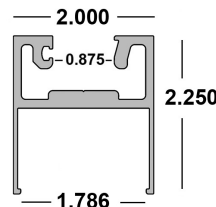

**Cover Plate for Bottom Channel x 16'**  
**52-63-11327 6063-T6**  
*Fits the 2.5" & 3.5" Post Systems; Mates with 28-63-715*

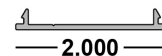

**RAILING & FENCE 12**





# OFFSET GLASS RAILING - NEW!

**2.5" Post System**  
**Mechanical/Welded Combo**  
**Accepts 7/16" and 9/16" Glass**  
**Tested and Engineered System**



**NOW OFFERING:**  
**CARDINAL GLASS!**  
 For more information:  
[glass@easternmetal.com](mailto:glass@easternmetal.com)

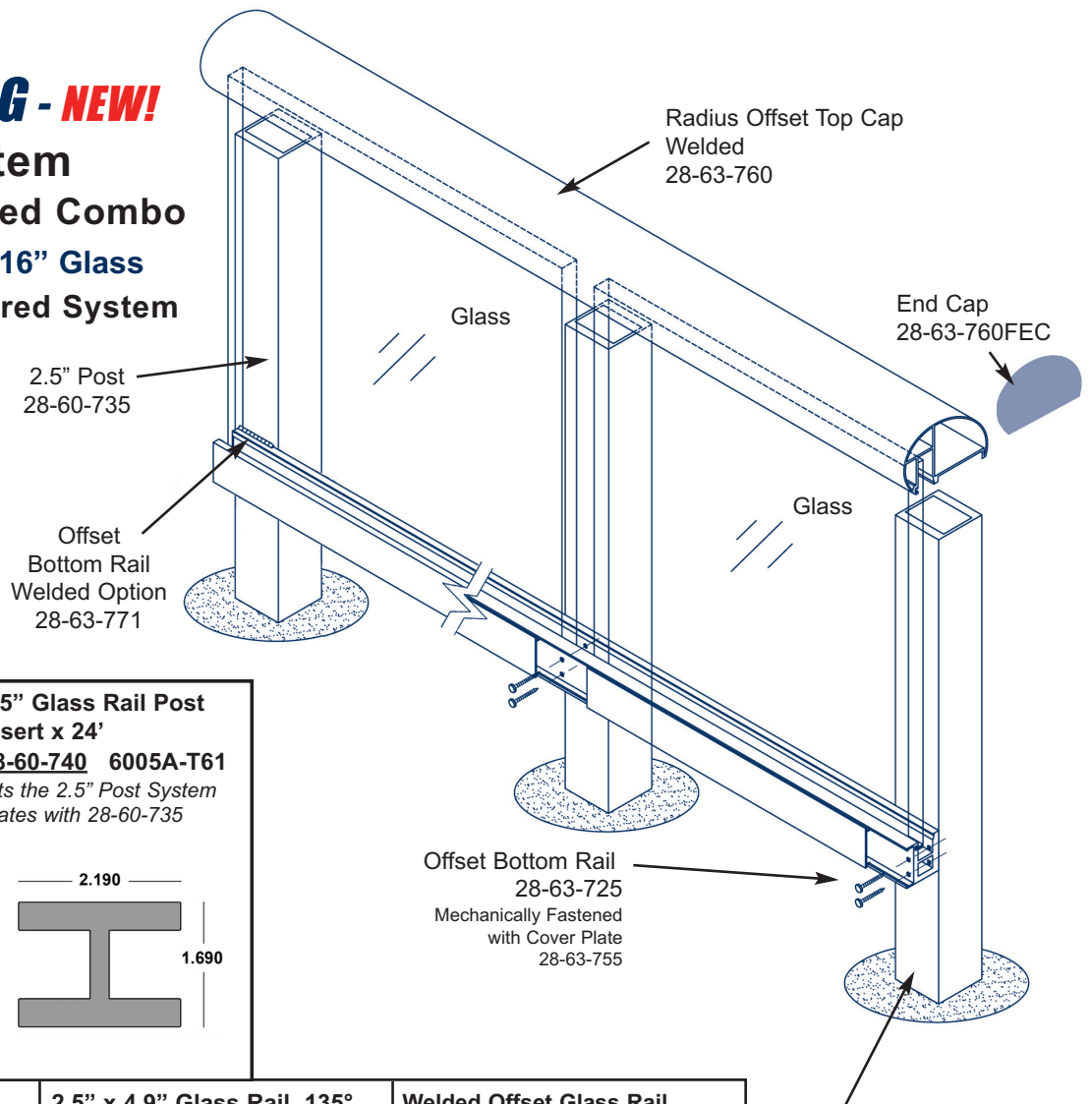

**2.5" Glass Rail Inline Post x 24'**  
**28-60-735** 6005A-T61  
 Mates with 28-60-740; Fits the 2.5" Post System

**2.5" Glass Rail Post Insert x 24'**  
**28-60-740** 6005A-T61  
 Fits the 2.5" Post System Mates with 28-60-735

**2.5" Glass Rail Corner Post x 24'**  
**28-60-730** 6005A-T61  
 Fit the 2.5" Post System

**2.5" x 4.9" Glass Rail 135° Post x 24'**  
**28-60-770** 6005A-T61  
 Fits the 2.5" Post System

**Welded Offset Glass Rail Bottom Channel x 24'**  
**28-63-771** 6063-T6  
 Fits the 2.5" & 3.5" Post Systems

2.5" Post - Standard (shown) 28-60-735  
 Corner Option 28-60-730 (for perpendicular attachment)  
 Engineering available by request

**5" Radius Offset Glass Rail Top Cap x 24'**  
**28-63-760** 6063-T6  
 Fits the 2.5" Post System  
**28-63-760FEC** End Cap

**Top Cap End Cap 28-63-760FEC** End Cap  
 Fits **28-63-760**

**Cover Plate for Offset Bottom Channel x 24'**  
**28-63-755** (Mechanical) 6063-T6  
 Fits the 2.5" & 3.5" Post Systems Mates with 28-63-725

**Mechanical Offset Glass Rail Bottom Channel x 24'**  
**28-63-725** 6063-T6 Fits the 2.5" & 3.5" Post Systems; Mates with 28-63-755

# OFFSET GLASS RAILING - NEW!

**3.5" Post System**  
**Mechanical/Welded Combo**  
**Accepts 7/16" and 9/16" Glass**  
**Tested and Engineered System**



**NOW OFFERING:**  
**CARDINAL GLASS!**

For more information:  
[glass@easternmetal.com](mailto:glass@easternmetal.com)

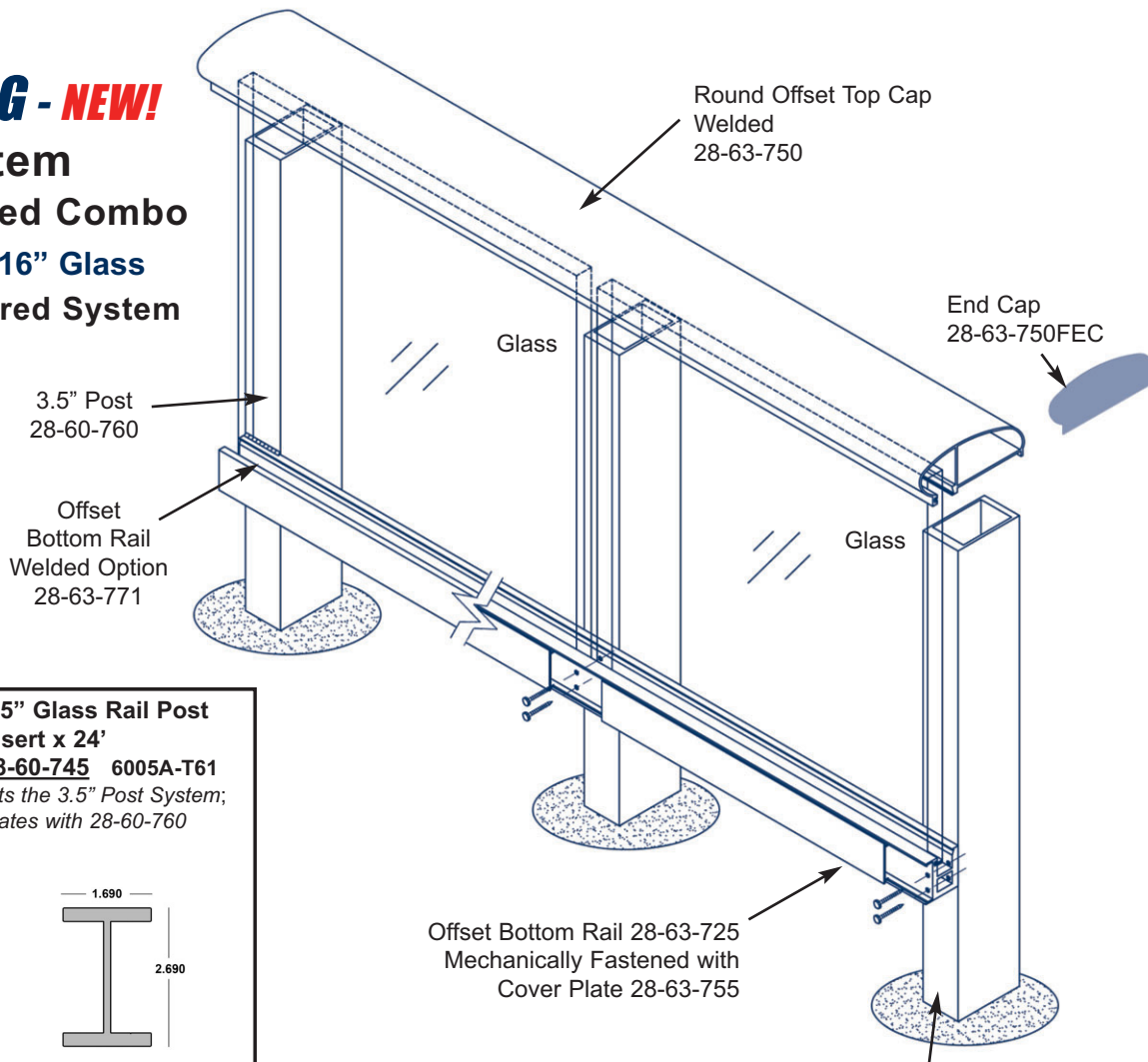

**3.5" x 2" Glass Rail Inline Post x 24'**  
**28-60-760 6005A-T61**  
*Fits the 3.5" Post System; Mates with I-Bar Post Insert 28-60-745*

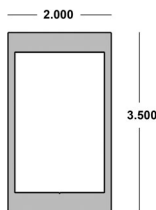

**3.5" Glass Rail Post Insert x 24'**  
**28-60-745 6005A-T61**  
*Fits the 3.5" Post System; Mates with 28-60-760*

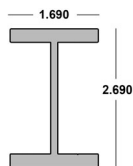

**3.5" x 3.5" Glass Rail Corner Post x 24'**  
**28-60-765 6005A-T61**  
*Fits the 3.5" Post System; Mates with 3" Sq Tube Post Insert 52-61-750*

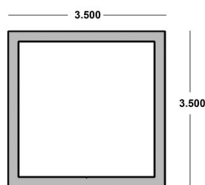

**3" Square Tube Post Insert x 18'**  
**52-61-750 6061-T6**  
*Fits the 3.5" Post System; Mates with 28-60-765*

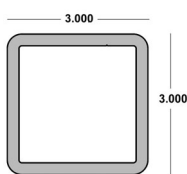

**3.5" x 5.47" Glass Rail 135° Post x 24'**  
**28-60-775 6005A-T61**  
*Fits the 3.5" Post System*

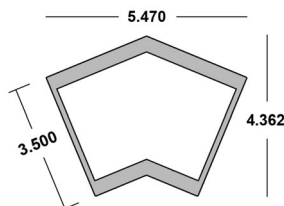

3.5" Post Standard (shown) 28-60-760  
 Corner Option 28-60-765 (for perpendicular attachment)

*Engineering available by request*

**6" Radius Offset Glass Rail Top Cap x 24'**  
**28-63-750 6063-T6**  
*Fits the 3.5" Post System*  
**28-63-750FEC End Cap**

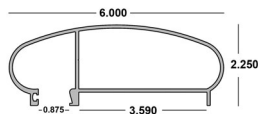

**Top Cap End Cap 28-63-750FEC End Cap**  
 Fits **28-63-750**



**Cover Plate for Offset Bottom Channel x 24'**  
**28-63-755 (Mechanical) 6063-T6**  
*Fits the 2.5" & 3.5" Post Systems; Mates with 28-63-725*

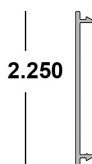

**Mechanical Offset Glass Rail Bottom Channel x 24'**  
**28-63-725 6063-T6**  
*Fits the 2.5" & 3.5" Post Systems; Mates with 28-63-755*

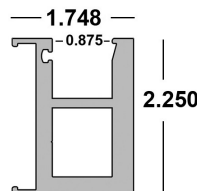

**Welded Offset Glass Rail Bottom Channel x 24'**  
**28-63-771 6063-T6**  
*Fits the 2.5" & 3.5" Post Systems*

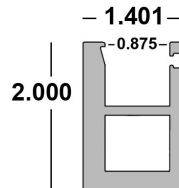

**RAILING & FENCE 14**



# GLASS RAILING GLAZING - NEW!

For 7/8 Glass Pockets using 7/16" and 9/16" Glass

Used with our Tested and Engineered Systems (Fence & Railing 10-14)

**LAMINATED GLASS** (sized by order) - *Now available from Eastern Metal Supply!*

- 7/16" Laminated Glass with vertical polished edge
- 0.035 SGP between 3/16" Tempered Glass • Design Pressure = +/-130
- 9/16" Laminated Glass with vertical polished edge
- 0.035 SGP between 1/4" Tempered Glass • Design Pressure = +/-190



NOW OFFERING:  
**CARDINAL**  
GLASS!

For more information:  
[glass@easternmetal.com](mailto:glass@easternmetal.com)

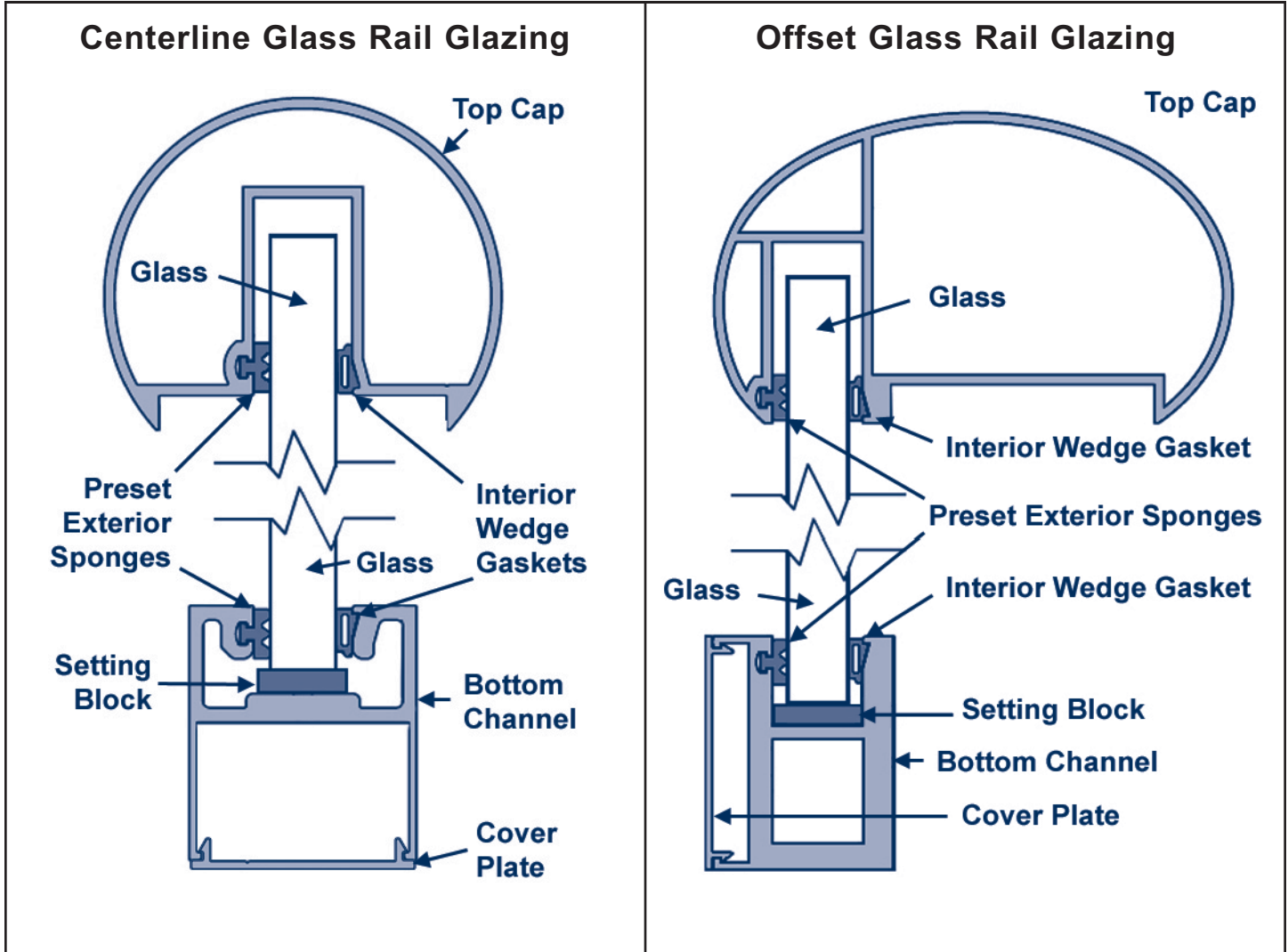

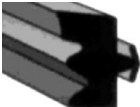
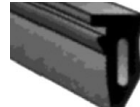
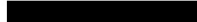
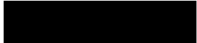

<p>Preset Exterior Sponge - 250' rolls <u>WW-B090</u> (sponge) Santoprene Gasket .125 face clearance, .250 centerline 9/16" Glass</p> 	<p>Preset Exterior Sponge - 250' rolls <u>WW-B140</u> (sponge) Santoprene Gasket .250 face clearance, .250 centerline 7/16" Glass</p> 	<p>Interior Wedge Gaskets - 250' rolls <u>WW-W514</u> Santoprene Gasket .187 face clearance, .062 nub Both Glass Types</p> 	<p>Centerline Neoprene Setting Block <u>WW-BN02164</u> 1/8 x 1 x 4</p> 	<p>Offset Neoprene Setting Block <u>WW-BN04164</u> 1/4 x 1 x 4</p> 
---	---	--	--	--

RAILING & FENCE 15

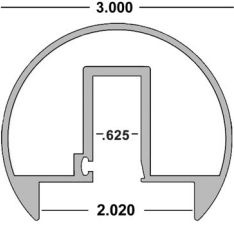
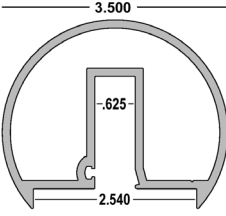
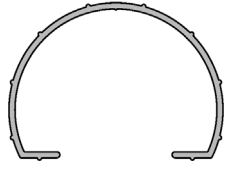
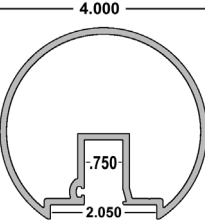
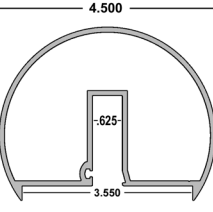
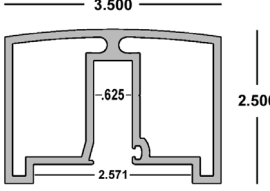
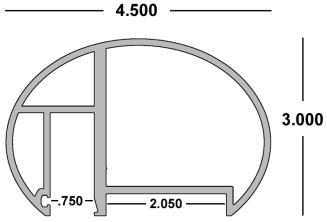
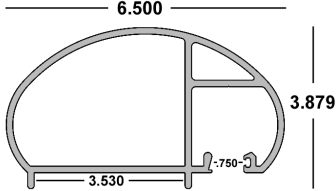
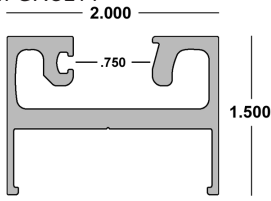
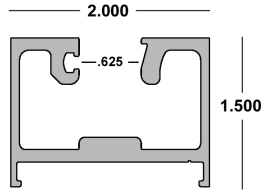
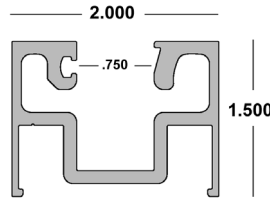
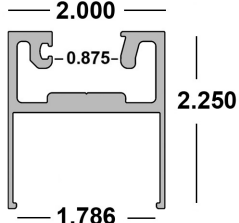
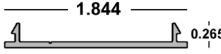
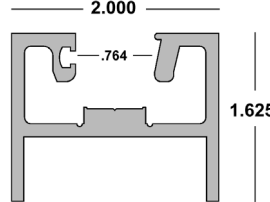

<p><b>3" Round Glass Cap</b>  <b>MILL ORDER 52-63-12183 - GR104</b>  <i>wall:0.125; with 1.500 deep glass pocket</i></p> 	<p><b>3-1/2" Round Glass Cap X 24'</b>  <b>52-63-10740 - GR108</b>  <i>wall:0.125; with 1.750 deep glass pocket</i>  <i>Mates with GRS110</i></p> 	<p><b>Glass Rail Inner Sleeve x 10' - RS110</b>  <b>52-63-8915</b> <i>wall:0.090</i>  <i>Mates with GR108</i></p> 
<p><b>4" Round Glass Cap</b>  <b>MILL ORDER 52-63-9402 - GR116</b>  <i>wall:0.125; with 1.250 deep glass pocket</i>  <i>Accepts 2" Post</i></p> 	<p><b>4-1/2" Round Top Cap</b>  <b>MILL ORDER 52-63-11470 - GR118</b>  <i>wall:0.105; with 1.750 deep glass pocket</i>  <i>Mates with GR312 (3.5" Post)</i></p> 	<p><b>3-1/2" x 2-1/2" Rect Glass Top Cap</b>  <b>MILL ORDER 52-63-11065 - GR122</b>  <i>wall:0.125; with 1.680 deep glass pocket</i>  <i>Accepts 2.5" Post</i></p> 
<p><b>4-1/2" Offset Oval Glass Cap</b>  <b>MILL ORDER 52-63-13034 - GR300</b>  <i>wall:0.110; with 1.75 deep glass channel</i>  <i>Accepts 2" Post</i></p> 	<p><b>6-1/2" x 3-3/4" Offset Oval Glass Rail Cap - GR304</b>  <b>MILL ORDER 52-63-8500</b> <i>wall:0.150</i>  <i>with 2.00 deep glass channel; Mates with GR312 (3.5" Post)</i></p> 	
<p><b>2" x 1-1/2" Glass Bottom Channel x 24'</b>  <b>MILL ORDER 52-63-10348 - GRC202</b>  <i>wall:0.090; with 0.687 deep glass pocket;</i>  <i>mates with GRC214</i></p> 	<p><b>2" x 1-1/2" Glass Bottom Channel x 24' - GRC204</b>  <b>52-63-10741</b> <i>wall:0.090</i>  <i>with 1" deep glass pocket; Can be used as a Mid Rail when inverted; mates with GRC214</i></p> 	<p><b>2" x 1-1/2" Mid Rail Glass Channel x 24' - GRC210</b>  <b>MILL ORDER 52-63-9940</b> <i>wall:0.090</i>  <i>with 1.250 deep glass pocket; mates with GRC214</i></p> 
<p><b>2" Centerline Glass Rail Bottom Channel x 24'</b>  <b>28-63-715</b> 6005A-T61  <i>Mates with 52-63-11327</i></p> 	<p><b>Cover Plate x 16' - GRC214</b>  <b>52-63-11327</b> <i>wall:0.090</i>  <i>mates with GRC202, GRC204, GRC210 and 28-63-715</i></p> 	<p><b>2" x 1-5/8" Glass Bottom Channel</b>  <b>MILL ORDER 52-63-12101 - GRC206</b>  <i>wall:0.125; with 0.875 deep glass pocket</i></p> 

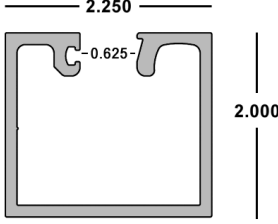
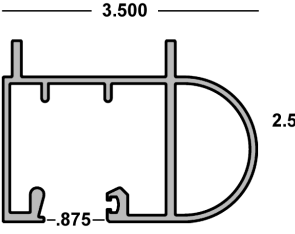
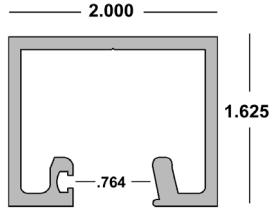
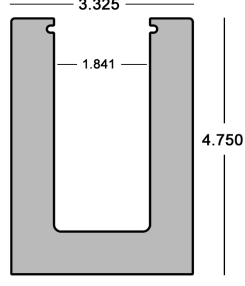
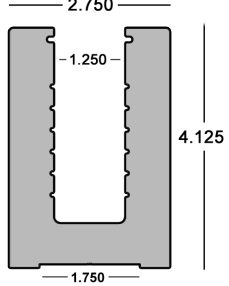
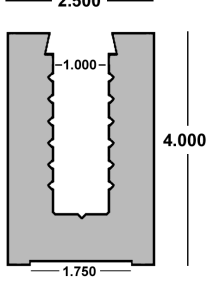
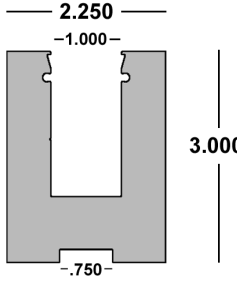
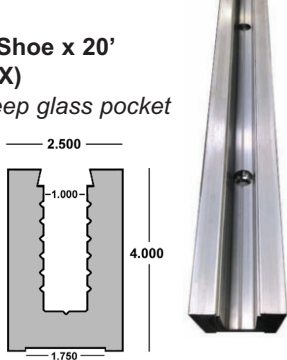
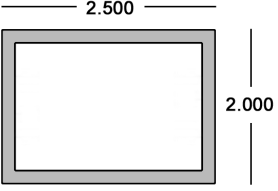
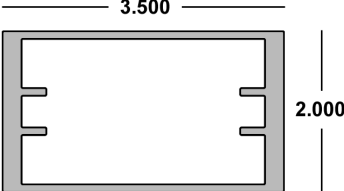
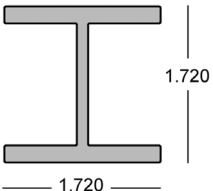
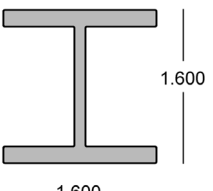



<p><b>2-1/4" x 2" Glass Channel</b>  <b>MILL ORDER 52-63-13991 - GRC213</b>  <i>wall:0.125; with 1.500 deep glass pocket</i></p> 	<p><b>3-1/2" x 2-1/2" Offset Bottom Channel</b>  <b>MILL ORDER 52-63-13138 - GR310</b>  <i>wall:0.090; with 1.75 deep glass channel</i></p> 	<p><b>2" x 1-5/8" Mid Rail Glass Channel</b>  <b>MILL ORDER 52-63-12798 - GRC212</b>  <i>wall:0.125; with 1.500 deep glass pocket</i></p> 
<p><b>3.325" x 4.75" Glass Base Shoe x 10'</b>  <b>28-63-077</b>  <i>with 3.980 deep glass pocket</i></p> 	<p><b>2.75" x 4.125" Glass Base Shoe x 20'</b>  <b>51-63-327</b>  <i>with 3.125 deep glass pocket</i></p> 	<p><b>2.50" x 4" Glass Base Shoe x 20'</b>  <b>51-63-325</b>  <i>with 3.125 deep glass pocket</i></p> 
<p><b>2.25" x 3" Glass Glass Base Shoe</b>  <b>MILL ORDER 52-63-10157</b>  <i>wall:0.625 with 2.063 deep glass pocket</i></p> 	<p><b>2.50" x 4" Glass Base Shoe x 20'</b>  <b>51-63-326 (TX)</b>  <i>with 3.125 deep glass pocket</i>  <i>Pre-Fabbed with 20 Holes</i></p> 	
<p><b>Glass Rail Post x 24'</b>  <b>20-61-270</b>  <i>2 x 2-1/2 x 1/8 Rect Tube 6061 T6</i></p> 	<p><b>3.5" x 2" Heavy Duty Glass Rail Post</b>  <b>MILL ORDER 52-61-2056 - GR312</b>  <i>wall:0.094; Receives 3/8" x 3" flat bar; Mates with GRC302 &amp; GRC304</i></p> 	<p><b>Glass Rail Post</b></p> <ul style="list-style-type: none"> <li>19-61-208 2 x .188 (6061-T6)</li> <li>19-61-212 2 x .250 (6061-T6)</li> <li>19-63-210 2 x .125</li> <li>19-61-210 2 x .125 (6061-T6)</li> <li>52-61-936 2 x .125 (6061-T6)</li> <li>19-63-211 2 x .188</li> <li>52-61-1128 2 x .188 w/rad (6061-T6)</li> <li>28-60-735 2.50 x .125/.375 (6005A-T61)</li> <li>28-60-730 2.50 x .375 (6005A-T61)</li> <li>MILL ORDER 2.50 x .188 (52-61-3402)</li> <li>28-60-760 3.50 x 2.00 x .125/.375 (6005A-T61)</li> <li>28-60-765 3.50 x .125 (6005A-T61)</li> </ul>
<p><b>2" Square Post Stiffener x 12'</b>  <b>52-61-2163</b> for 2" x .125 Sq Tube</p> 	<p><b>2" Square Post Stiffener x 12'</b>  <b>52-61-4452</b> for 2" x .188 Sq Tube</p> 	 <p><b>NOW OFFERING:  <b>CARDINAL GLASS!</b></b></p> <p>For more information:  <a href="mailto:glass@easternmetal.com">glass@easternmetal.com</a></p>





**RAILING & FENCE 17**

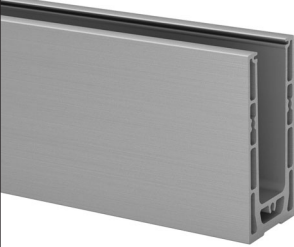
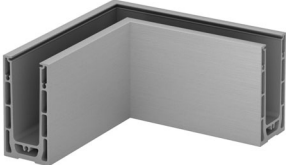





# BRUSHED ALUMINUM GLASS RAILING BASE SHOE

**NOW STOCKING** - Call your Sales Representative for more Information

<p><b>Easy Glass Smart Base Shoe Top Mount</b>  <u>70-70-10S</u> x 10'  <u>70-70-20S</u> x 20'                  Brushed Aluminum                  Satin Anodized</p> 	<p><b>Easy Glass Smart Base Shoe Corner Top Mount</b>  <u>70-90-0TS</u>                  Brushed Aluminum                  Satin Anodized</p> 	<p><b>Easy Glass Smart End Cap Top Mount</b>  <u>70-50-00S</u>                  Left &amp; Right; Brushed                  Aluminum Satin Anodized</p> 	<p><b>Easy Glass Smart Drainage Profile</b>  <u>70-69-48S</u> 4 pcs                  Brushed Aluminum                  Satin Anodized</p> 
---	---	--	---

<p><b>Easy Glass Smart Base Shoe Fascia Mount</b>  <u>72-72-10S</u> x 10'  <u>72-72-20S</u> x 20'                  Brushed Aluminum                  Satin Anodized</p> 	<p><b>Easy Glass Smart End Cap Fascia Mount</b>  <u>72-50-0LS</u> Left  <u>72-50-0RS</u> Right                  Brushed Aluminum                  Satin Anodized</p> 	<p><b>Easy Glass Prime Blind Plug</b>  <u>99-33-333</u></p> 	<p><b>Easy Glass Smart Rubber Set Adjustable</b>                  Includes 20' of both                  gaskets and 25 Discs  <u>99-15L-20S</u>                  for 1/2" glass   <u>99-916L-20S</u>                  for 9/16" glass</p> 	<p><b>Disc Adjusting Tool</b>  <u>77-084</u></p> 
--	--	---	--	---

<p><b>Easy Glass Max Base Shoe Top Mount</b>  <u>70-70-08M</u> x 8.2'                  Brushed Aluminum                  Satin Anodized</p> 	<p><b>Easy Glass Max Base Shoe Corner Top Mount</b>  <u>70-90-0TM</u>                  Brushed Aluminum                  Satin Anodized                  2 pcs</p> 	<p><b>Easy Glass Max End Cap Top Mount</b>  <u>70-50-0TM</u>                  Left &amp; Right; Brushed                  Aluminum Satin                  Anodized</p> 	<p><b>Rubber Set Easy Glass Max for 27/32LAM</b>                  Includes 16' of both                  gaskets and 20 Wedges  <u>99-2732-M</u>                  for 27/32" laminated                  glass</p> 	<p><b>Easy Glass Multitool</b>  <u>77-071</u></p> 
--	--	---	---	---



**NOW OFFERING CARDINAL GLASS!** Info: [glass@easternmetal.com](mailto:glass@easternmetal.com)



RAILING & FENCE 18



**Eastern Metal Supply** [www.easternmetal.com](http://www.easternmetal.com) • [info@easternmetal.com](mailto:info@easternmetal.com) 11/17/21  
 FL: 800-432-2204 • NC/DE/GA: 800-343-8154 • TX/AR/LA: 800-996-6061 • MO/OH/IN: 888-822-6061

# 316 STAINLESS STEEL ROUND POST CABLE RAILING

**NOW STOCKING** - Call your Sales Representative for more Information







<p><b>1.9" ROUND Stainless Steel Cable Railing Pre-fabricated Post - Floor Mount</b>                  Accepts 1/8" or 5/32" Fast Fix Cable Sets  <b>Ø1.9" x 0.156"</b>  <b>36" Post (uses 10 Cables; 3" spacing)</b>                  C8490814481 A, Anchor Post                  C8490834481 B, Center/Line Post                  C8490824481 C, Receiver Post                  C8490874481 90°, Corner Post</p> <p><b>42" Post (uses 12 Cables; 3" spacing)</b>                  C8490914481 A, Anchor Post                  C8490934481 B, Center/Line Post                  C8490924481 C, Receiver Post                  C8490974481 90°, Corner Post</p> 		<p><b>1.9 ROUND Stainless Steel Cable Railing Pre-fabricated Post - Fascia Mount</b>                  Accepts 1/8" or 5/32" Fast Fix Cable Sets  <b>Ø1.9" x 0.156"</b>  <b>36" Post (uses 10 Cables; 3" spacing)</b>                  C8490314481 A, Anchor Post                  C8490334481 B, Center/Line Post                  C8490324481 C, Receiver Post</p> <p><b>42" Post (uses 12 Cables; 3" spacing)</b>                  C8490414481 A, Anchor Post                  C8490434481 B, Center/Line Post                  C8490424481 C, Receiver Post</p> 		
<p><b>ROUND Stainless Steel Tube Ø1-1/2" x 0.078"</b>                  68-10-081 x 8.2'                  68-10-161 x 16.4'</p> 	<p><b>Flush Elbow, 90°</b>                  68-91-001                  Curved Stainless Steel                  2 pcs</p> 	<p><b>Flush Elbow, 90°</b>                  68-90-001                  Rounded Stainless Steel                  2 pcs</p> 	<p><b>Adjustable Flush Angle (0°-70°)</b>                  68-90-A01                  Stainless Steel                  2 pcs</p> 	<p><b>Tube Connector, Easy Hit, Tube Ø1-1/2" x 0.078"</b>                  68-80-001                  2 pcs</p> 
<p><b>Arched End Cap Easy Hit</b>                  68-5R-001                  Stainless Steel                  2 pcs</p> 	<p><b>Domed End Cap Easy Hit</b>                  68-5D-001                  Stainless Steel                  2 pcs</p> 	<p><b>Wall Flange</b>                  68-05-WF1                  Stainless Steel                  2 pcs</p> 	<p><b>Wall Flange with Blind Connection</b>                  68-00-WF1                  2 pcs</p> 	<p><b>Hexagon Socket Button Head Screw</b>                  68-00-111 50 pcs</p> 
<p><b>Fast Fix Cable-Sets</b>                  1/8" Cable                  68-125-08 x 8'                  68-125-16 x 16.4'                  68-125-24 x 24.5'                  68-125-32 x 32.8'                  68-125-41 x 41'</p> <p>5/32" Cable                  68-187-08 x 8'                  68-187-16 x 16.4'                  68-187-24 x 24.5'                  68-187-32 x 32.8'                  68-187-41 x 41'</p> 	<p><b>SS-Glue</b>                  1.69 fl.oz.                  68-13-31</p> 	<p><b>SS-Cleaner</b>                  10.1 fl.oz.                  68-88-23</p> 	<p><b>SS-Protector</b>                  16.9 fl.oz.                  68-88-63</p> 	<p><b>Scotch-Brite 3M Abrasive Pad</b>                  68-88-25 10 pcs</p> 

**RAILING & FENCE 19**



# 316 STAINLESS STEEL RECTANGULAR POST CABLE RAILING

**NOW STOCKING** - Call your Sales Representative for more Information













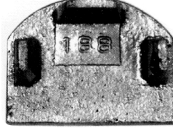

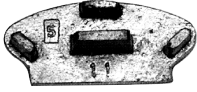

<p><b>RECTANGULAR Stainless Steel Cable Railing</b>  <b>Pre-fabricated Post - Floor &amp; Fascia Mount</b>          Accepts 1/8" or 5/32" Fast Fix Cable Sets  <b>2.36 x 1.18 x 0.1"</b>  <b>36" Post (uses 10 Cables; 3" spacing)</b>          C8490810631      A, Anchor Post          C8490830631      B, Center/Line Post          C8490820631      C, Receiver Post    <b>42" Post (uses 12 Cables; 3" spacing)</b>          C8490910631      A, Anchor Post          C8490930631      B, Center/Line Post          C8490920631      C, Receiver Post</p> 	<p><b>RECTANGULAR Stainless Steel Tube</b>  <b>2.36" x 0.79" x 0.078"</b>  <u>68-10-082</u>      x 8.2'  <u>68-10-162</u>      x 16.4'</p> 		
<p><b>Adjustable Flush Angle Square Line (0°-70°)</b>  <u>68-90-A62</u>          2 pcs</p> 	<p><b>Flush Elbow Square Line, 90°</b>  <u>68-90-062</u>          2 pcs</p> 	<p><b>Tube Connector Square Line, Easy Hit</b>  <u>68-80-002</u>          2 pcs</p> 	<p><b>Wall Flange Square Line</b>  <u>68-00-WF2</u>          2 pcs</p> 
<p><b>Flat End Cap Square Line, Easy Hit</b>  <u>68-50-002</u>          2 pcs</p> 	<p><b>Handrail Bracket for Wall Mounting, M8 Thread</b>  <u>68-03-W01</u>          2 pcs</p> 	<p><b>Hanger Bolt</b>  <u>68-00-086</u>          50 pcs</p>  <p><b>Hexagon Socket Countersunk Head Screw</b>  <u>68-00-113</u>          50 pcs</p> 	<p><b>Fast Fix Cable-Sets</b>          1/8" Cable  <u>68-125-08</u>      x 8'  <u>68-125-16</u>      x 16.4'  <u>68-125-24</u>      x 24.5'  <u>68-125-32</u>      x 32.8'  <u>68-125-41</u>      x 41'          5/32" Cable  <u>68-187-08</u>      x 8'  <u>68-187-16</u>      x 16.4'  <u>68-187-24</u>      x 24.5'  <u>68-187-32</u>      x 32.8'  <u>68-187-41</u>      x 41'</p> 
<p><b>SS-Glue</b>  <b>1.69 fl.oz.</b>  <u>68-13-31</u></p> 	<p><b>SS-Cleaner</b>  <b>10.1 fl.oz.</b>  <u>68-88-23</u></p> 	<p><b>SS-Protector</b>  <b>16.9 fl.oz.</b>  <u>68-88-63</u></p> 	<p><b>Scotch-Brite 3M Abrasive Pad</b>  <u>68-88-25</u>      10 pcs</p> 

RAILING & FENCE 20



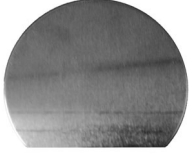

# CASTINGS

<p><b>HR1 End Cap</b> 21-DC-100 Die Cast</p>  <p><b>Accepts:</b> Top Cap - HR-1-COLOR</p>	<p><b>HR10 Flat End Cap</b> 52-00-147 Sand Cast</p>  <p><b>Accepts:</b> Top Cap - HR-10-COLOR</p>	<p><b>HR8 End Cap</b> 21-00-131 Sand Cast</p>  <p><b>Accepts:</b> Top Cap - HR-8-COLOR</p>	<p><b>HR14 End Cap</b> 21-00-114 Sand Cast</p>  <p><b>Accepts:</b> Top Cap - HR-14-COLOR</p>	<p><b>Handicap Rail End Cap</b> 21-DC-114 Die Cast</p>  <p><b>Accepts:</b> Top Cap - HR-14-COLOR</p>																						
<p><b>Handicap Rail End Cap</b> 21-00-294 Sand Cast</p>  <p><b>Accepts:</b> Grip Rail - 52-63-1641</p>	<p><b>2-1/4" x 6" End Cap</b> 21-00-150 Sand Cast</p>  <p><b>Accepts:</b> Top Cap - 28-63-260</p>	<p><b>2-5/8" x 1" End Cap</b> 21-00-135 Sand Cast</p>  <p><b>Accepts:</b> Hollow Cap #129 - 28-63-210 Hollow Cap #130 - 28-63-200</p>	<p><b>2-5/8" x 1-1/2" Flat End Cap</b> 21-00-140F Sand Cast</p>  <p><b>Accepts:</b> Hollow Cap #135 - 28-63-215</p>	<p><b>2-5/8" x 1-1/2" 5052 Flat End Cap</b> 21-5052-140 <i>Fabricated from Aluminum Sheet</i></p>  <p><b>Accepts:</b> Hollow Cap #135 - 28-63-215</p>																						
<p><b>3" Oval End Cap</b> 21-00-000 Sand Cast</p>  <p><b>Accepts:</b> Top Cap #147 - 28-63-267</p>	<p><b>End Cap RW-29</b> 2-5/8 x 1 Dixie End Cap 21-00-235 Sand Cast</p>  <p><b>Accepts:</b> Hollow Dixie Cap - 28-63-290</p>	<p><b>End Cap RW-30</b> 2-5/8 x 1-1/2 Dixie Cap 21-00-245 Sand Cast</p>  <p><b>Accepts:</b> Hollow Dixie Cap - 28-63-295</p>	<p><b>Flat End Cap RW-30</b> 2-5/8 x 1-1/2 Dixie Cap 21-00-245F Sand Cast</p>  <p><b>Accepts:</b> Hollow Dixie Cap - 28-63-295</p>	<p><b>3" Round 5052 Flat End Cap</b> 21-5052-120 <i>Fabricated from Aluminum Sheet</i></p>  <p><b>Accepts:</b> Top Cap #149 - 28-63-265</p>																						
<p><b>1-1/4" SCH 40 End Plug</b> 21-00-180 Sand Cast</p> 	<p><b>1-1/2" SCH 40 End Plug</b> 21-00-181 Sand Cast</p> 	<p><b>SCH 40 Aluminum Pipe End Caps</b></p> <table border="1"> <thead> <tr> <th>Mill Finish</th> <th>Pipe Size</th> </tr> </thead> <tbody> <tr> <td>APC-100-MF</td> <td>1</td> </tr> <tr> <td>APC-125-MF</td> <td>1-1/4</td> </tr> <tr> <td>APC-150-MF</td> <td>1-1/2</td> </tr> <tr> <td>APC-200-MF</td> <td>2</td> </tr> </tbody> </table>	Mill Finish	Pipe Size	APC-100-MF	1	APC-125-MF	1-1/4	APC-150-MF	1-1/2	APC-200-MF	2	<p><b>SCH 40 Aluminum Pipe End Caps</b></p> <table border="1"> <thead> <tr> <th>Anodized</th> <th>Pipe Size</th> </tr> </thead> <tbody> <tr> <td>APC-750</td> <td>3/4</td> </tr> <tr> <td>APC-100</td> <td>1</td> </tr> <tr> <td>APC-125</td> <td>1-1/4</td> </tr> <tr> <td>APC-150</td> <td>1-1/2</td> </tr> <tr> <td>APC-200</td> <td>2</td> </tr> </tbody> </table>	Anodized	Pipe Size	APC-750	3/4	APC-100	1	APC-125	1-1/4	APC-150	1-1/2	APC-200	2	<p><b>SCH 40 Aluminum Pipe End Caps</b> <i>See Railing section for Pipe Inserts - Railing p11</i></p> 
Mill Finish	Pipe Size																									
APC-100-MF	1																									
APC-125-MF	1-1/4																									
APC-150-MF	1-1/2																									
APC-200-MF	2																									
Anodized	Pipe Size																									
APC-750	3/4																									
APC-100	1																									
APC-125	1-1/4																									
APC-150	1-1/2																									
APC-200	2																									

CASTINGS 01



<p><b>HR1 Wall Mount</b> <u>21-00-187</u> Die Cast</p>  <p>2.88 3.25 1.00 1.29 Deep</p> <p><b>Accepts:</b> Top Cap - HR-1-COLOR</p>	<p><b>HR3 Wall Mount</b> <u>21-00-316</u> Die Cast</p>  <p>2.33 2.33 1.38 Deep</p> <p><b>Accepts:</b> Bottom Channel - HR-3-COLOR</p>	<p><b>HR10 Wall Mount</b> <u>21-00-186</u> Sand Cast</p>  <p>2.75 2.625 1.00 1.00 Deep</p> <p><b>Accepts:</b> Top Cap - HR-10-COLOR</p>	<p><b>HR12 Wall Mount</b> <u>21-00-185</u> Die Cast</p>  <p>2.00 2.63 1.00 1.00 Deep</p> <p><b>Accepts:</b> Snap Channel HR-12-COLOR</p>	<p><b>HR12A Wall Mount</b> <u>21-DC-183</u> Die Cast</p>  <p>1.90 2.45 0.85 1.425 Deep</p> <p><b>Accepts:</b> Bottom Channel - HR-12A Bottom Channel - HR-12B Channel - 13-63-300</p>	
<p><b>HR14 Wall Mount</b> <u>21-DC-155</u> Die Cast</p>  <p>2.385 2.90 0.85 1.435 Deep</p> <p><b>Accepts:</b> Top Cap - HR-14-COLOR</p>	<p><b>2" x 1" Channel Wall Mount</b> <u>21-00-190</u> Die Cast</p>  <p>2.36 2.50 1.125 Deep</p> <p><b>Accepts:</b> Channel - 13-63-266 Channel - 13-63-267 Mid Rail Tube - 52-63-11317</p>	<p><b>2" x 1" Double Ear Channel Wall Mount</b> <u>21-00-191</u> Die Cast</p>  <p><b>Accepts:</b> Channel - 13-63-266 Channel - 13-63-267 Mid Rail Tube - 52-63-11317</p>	<p><b>2" x 2" Wall Mount</b> <u>21-00-266</u> Sand Cast</p>  <p>2.50 3.625 1.25 Deep</p> <p><b>Accepts:</b> HR4; 2 x 2</p>	<p><b>HR 8 Wall Mount CLOSEOUT</b> <u>21-00-063</u> Sand Cast</p>  <p>2.61 6.25 1.75 1.625 Deep</p> <p><b>Accepts:</b> Top Cap - HR-8-COLOR</p>	<p><b>2-1/4" x 4" Wall Mount</b> <u>21-00-190W</u> Sand Cast with Radius</p>  <p>2.375 5.625 1.00 1.50 Deep</p> <p><b>Accepts:</b> Top Cap #140 - 28-63-256</p>
<p><b>2-5/8" x 1" Wall Mount</b> <u>21-00-302</u> Sand Cast</p>  <p>3.00 2.625 1.00 .875 Deep</p> <p><b>Accepts:</b> Hollow Cap #129 - 28-63-210 Solid Cap #130 - 28-63-200</p>	<p><b>2-5/8" x 1-1/2" Wall Mount</b> <u>21-00-160</u> Sand Cast</p>  <p>3.00 3.50 1.25 Deep</p> <p><b>Accepts:</b> Top Cap #135 - 28-63-215</p>	<p><b>2-5/8" x 1" Dixie Cap Wall Mount RW-29</b> <u>21-00-230</u> Sand Cast</p>  <p>3.00 2.375 2.625 1.00 Deep</p> <p><b>Accepts:</b> Hollow Dixie Cap 28-63-290</p>	<p><b>2-5/8" x 1-1/2" Dixie Cap Wall Mount RW-30</b> <u>21-00-240</u> Sand Cast</p>  <p>2.90 2.85 2.625 1.00 Deep</p> <p><b>Accepts:</b> Hollow Dixie Cap - 28-63-295</p>	<p><b>3" Round Cap Wall Mount</b> Special Order <u>21-00-1850</u> Sand Cast</p>  <p>2.875 1.0 2.50 1.25 Deep</p> <p><b>Accepts:</b> Top Cap #149 - 28-63-265</p>	
<p><b>2" Square Floor Flange</b> <u>21-00-210TM</u> Sand Cast</p>  <p>5.00 2.50 1.25 Tall</p> <p><b>Accepts:</b> 2" Sq Tube; Snap Post HR-4-COLOR</p>	<p><b>HR #4A Floor Flange HD</b> <u>21-DC-196</u> Die Cast</p>  <p>4.35 4.38 1.30" Tall</p> <p><b>Accepts:</b> Snap Post HR-4A-COLOR</p>	<p><b>HR #4A Floor Flange</b> Special Order <u>21-00-195</u> Sand Cast</p>  <p>4.25 2.90 3" Tall</p> <p><b>Accepts:</b> Snap Post HR-4A-COLOR</p>	<p><b>1-1/2" Round Floor Flange</b> <u>21-00-314</u> Sand Cast</p>  <p>3.00 1.00 Tall</p> <p><b>Accepts:</b> 1-1/2" Round Tube</p>	<p><b>1-1/4" SCH 40 Floor Flange</b> <u>21-00-47</u> Sand Cast</p>  <p>3.375 1.00 Tall</p> <p><b>Accepts:</b> 1-1/4 SCH 40 Pipe 18-63-230</p>	<p><b>1-1/4" SCH 40 Floor Flange</b> <u>21-00-48</u> Sand Cast</p>  <p>3.840 0.80 Tall</p> <p><b>Accepts:</b> 1-1/4 SCH 40 Pipe 18-63-230</p>

CASTINGS 02



<p><b>1-1/2" Square Post Cap</b>  <u>21-00-174</u> Die Cast</p> 	<p><b>2" Square Post Cap #31</b>  21-00-175 Die Cast</p> 	<p><b>3" Flush Mount Square Post Cap (Inside Insert)</b>  <u>21-00-763</u> Sand Cast  .125 Wall  <i>Used with Universal Enclosure System</i></p> 	<p><b>3" Square Post Cap #76</b>  21-00-170 Die Cast</p> 	<p><b>3" Flat Pyramid Post Cap</b>  21-FT-170 Die Cast</p> 
<p><b>4" Square Post Cap #80</b>  51-00-137 Sand Cast</p> 	<p><b>4" Square Flat Top Pyramid Post Cap</b>  <u>51-FT-137</u> Die Cast</p> 	<p><b>5" Post Cap Casting</b>  <u>21-00-255</u> Sand Cast  <b>6" Post Cap Casting</b>  <u>21-00-264</u> Sand Cast</p> 	<p><b>6" Flat Top Post Cap</b>  <u>21-FT-264</u> Die Cast</p> 	<p><b>4" Ball Top for 3" Post</b>  <u>21-00-410</u> Sand Cast  <i>Round Base for Flag Post Outside Sleeve for 3" OD Post</i></p> 
<p><b>2-1/4" Ball Top for 3" Post</b>  21-00-097 Sand Cast  <i>Outside Sleeve for 3" Post</i></p> 	<p><b>2-1/4" Ball Top for 4" Post</b>  Special Order  <u>21-00-355</u> Sand Cast  <i>Outside Sleeve for 4" Post</i></p> 	<p><b>4" Ball Post Cap</b>  <u>21-00-600</u> Sand Cast  <i>Outside Sleeve for 4" Post</i></p> 	<p><b>2" Ball Post Cap</b>  <u>21-00-139</u> Sand Cast  <i>Outside Sleeve for 2" Post</i></p> 	
<p><b>3/4" Spear #2</b>  <u>21-00-307</u> Sand Cast  4.875" exposed height  0.750" insert depth</p>  <p><b>Accepts:</b>  3/4" x .063 Square Tube</p>	<p><b>1" Spear #9</b>  <u>21-00-444</u> Sand Cast  4.875" exposed height  0.750" insert depth</p>  <p><b>Accepts:</b>  1" x .063 Square Tube</p>	<p><b>3/4" Spear #4 (Round Top)</b>  <u>21-00-306</u> Sand Cast  4.125" exposed height  0.680" insert depth</p>  <p><b>Accepts:</b>  3/4" x .063 Square Tube</p>	<p><b>1" Spear (Round Top)</b>  <u>21-00-325</u> Sand Cast  4.50" exposed height  1.00" insert depth</p>  <p><b>Accepts:</b>  1" x .063 Square Tube</p>	

**CASTINGS 03**



**Decorative Aluminum Rings Castings**

Sand Cast

21-00-374 3-1/2" (2-3/4" ID)

21-00-377 3-3/4" (2-3/4" ID)

21-00-415 5" (3-7/8" ID)



**4" Decorative Aluminum Ring  
0.5" x .062" Formed from Extruded  
Square Tube**

21-00-375 (3.90 OD; 3" ID)



**1" Deco Knot**

21-00-1400 Die Cast



**Bullet Rail End Cap**

21-00-715



**Hard-Rok  
61-00-007**

Contains no gypsum or chlorides; Quick setting  
anchoring Cement;  
5 Gallon Bucket



**Quik Rok  
61-00-001**

Anchoring Cement;  
5 Gallon Bucket  
**NEVER** to be used to anchor balcony railing  
or any similar human life safety structures



**Mark V Gate Hinge  
52-63-8793 (Heavy Duty)  
with base plate**

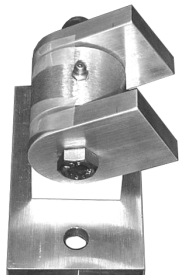

**Mark 4 Gate Hinge  
52-63-9150 (Heavy Duty)  
without base plate**



CASTINGS 04

