















# ***Ferulok<sup>®</sup> Flareless Bite Type Fittings***

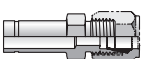

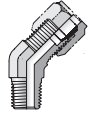
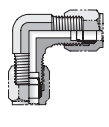
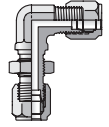
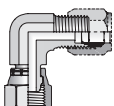
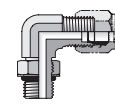
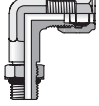
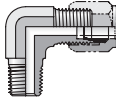
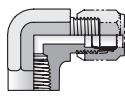
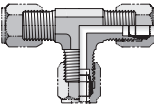
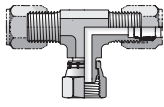
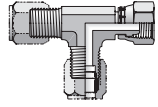
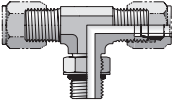
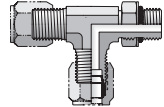
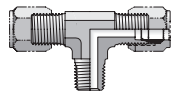
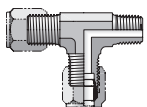
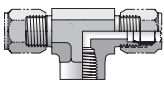
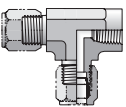
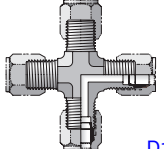
***The Fitting Authority***



<p><b>Nuts, Ferrules, Locknuts</b></p>	<p><b>BU</b> Nut</p>  <p>D8</p>	<p><b>TU</b> Ferrules</p>  <p>D8</p>	<p><b>WLN</b> Bulkhead Locknut</p>  <p>D8</p>	<p><b>Straights</b></p>	<p><b>HBU</b> Union</p>  <p>D8</p>
<p><b>LHBU</b> Large Hex Union</p>  <p>D9</p>	<p><b>WBU</b> Bulkhead Union</p>  <p>D9</p>	<p><b>F5BU</b> SAE-ORB / Flareless</p>  <p>D9</p>	<p><b>FBU</b> NPTF / Flareless</p>  <p>D9</p>	<p><b>GBU</b> NPTF / Flareless</p>  <p>D10</p>	<p><b>TRBU</b> Tube End Reducer</p>  <p>D10</p>
<p><b>45° Elbows</b></p>	<p><b>V5BU</b> SAE-ORB / Flareless</p>  <p>D10</p>	<p><b>VBU</b> NPTF / Flareless</p>  <p>D10</p>	<p><b>90° Elbows</b></p>	<p><b>EBU</b> Union Elbow</p>  <p>D11</p>	<p><b>WEBU</b> Bulkhead Union Elbow</p>  <p>D11</p>
<p><b>C6BU</b> Flareless Swivel/Flareless</p>  <p>D11</p>	<p><b>C5BU</b> SAE-ORB / Flareless</p>  <p>D11</p>	<p><b>CC5BU</b> SAE-ORB / Flareless</p>  <p>D12</p>	<p><b>CBU</b> NPTF / Flareless</p>  <p>D12</p>	<p><b>DBU</b> NPTF / Flareless</p>  <p>D12</p>	
<p><b>Tees</b></p>	<p><b>JBU</b> Union Tee</p>  <p>D13</p>	<p><b>S6BU</b> Swivel Branch Tee</p>  <p>D13</p>	<p><b>R6BU</b> Swivel Run Tee</p>  <p>D13</p>	<p><b>S5BU</b> SAE-ORB Branch Tee</p>  <p>D13</p>	<p><b>R5BU</b> SAE-ORB Run Tee</p>  <p>D14</p>
<p><b>SBU</b> NPTF Branch Tee</p>  <p>D14</p>	<p><b>RBU</b> NPTF Run Tee</p>  <p>D14</p>	<p><b>OBU</b> NPTF Branch Tee</p>  <p>D14</p>	<p><b>MBU</b> NPTF Run Tee</p>  <p>D15</p>	<p><b>Cross</b></p>	<p><b>KBU</b> Union Cross</p>  <p>D15</p>
<p><b>Plugs and Caps</b></p>	<p><b>PNU</b> Plug</p>  <p>D15</p>	<p><b>FNU</b> Cap</p>  <p>D15</p>			

Dimensions and pressures for reference only, subject to change.

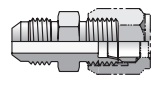
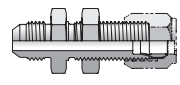
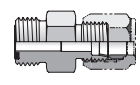
**Conversion Adapters** (Shown in Section L)

 <p>Conversion Adapters</p>	<p><b>XHBU</b> 37° Flare / Flareless</p>  <p>L4</p>	<p><b>XHBU2</b> 37° / Flareless Bulkhead</p>  <p>L4</p>	<p><b>BUHLO</b> ORFS / 24° Flareless</p>  <p>L4</p>
--	--	--	--

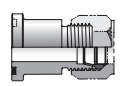
**Flange Adapters** (Shown in Section M)

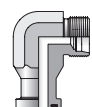
 <p>Flange Adapters</p>	<p><b>BUHQ1</b> Code 61 / Flareless</p>  <p>M10</p>	<p><b>BUVQ1</b> Code 61 / Flareless</p>  <p>M28</p>	<p><b>BUEQ1</b> Code 61 / Flareless</p>  <p>M29</p>
--	--	--	--

**O-Rings and Seals** (Shown in Section O)

 <p>O-Rings</p>	<p><b>SAE O-Ring</b></p>  <p>O3</p>
--	--

Dimensions and pressures for reference only, subject to change.

## Introduction

The basic flareless bite type fitting was first developed in Europe in the early 1930s. The Ferulok fitting was later developed by Parker Hannifin and introduced to the U.S. market in the mid-1940s. The Ferulok fitting design utilizes a combination of proven European features, coupled with many innovative product improvements instituted by Parker Hannifin. Today, the Ferulok fitting design and performance capabilities far exceed the strict requirements of SAE J514 and Military Standards (MILF18866). The Ferulok fitting is a flareless fitting that consists of a body, a one-piece precision machined ferrule, and a nut. On assembly, the ferrule “bites” into the outer surface of the tube with sufficient strength to hold the tube against pressure, without significant distortion of the inside tube diameter.

The ferrule also forms a pressure seal against the fitting body. Ferulok fittings have a visible bite, allowing the fitting assembler to visually inspect the bite quality, thus significantly minimizing the risk of improper assembly and related service problems.

Ferulok fittings are especially suitable for use with tube wall thickness ranging from medium to extra heavy. (Refer to Table D2, “Recommended Tube Wall Thickness.”) Ferulok’s robust construction and proven sealing characteristics have gained it popularity in diverse markets and applications. Ferulok fittings are routinely used in markets such as: machine tools, air compressors, chemical, military, oil refineries, paper making, thermoplastics processing, and many general industrial hydraulic applications.



Fig. D1 – Ferulok Components: Body, Ferrule and Nut

## Design and Construction

The three components of the Ferulok fitting are designed and manufactured to produce a high pressure, leak-free joint upon proper assembly.

**The Ferulok Body** – Ferulok fitting bodies are available in over thirty configurations. The shaped products (i.e. elbows, tees, crosses) are hot forged, then machined to the stringent Ferulok fitting specifications. The forging process used by Parker further improves the strength and metallurgical properties of the fitting material. Straight products are made from cold drawn bar stock. The cold drawing operation ensures consistently tight dimensional tolerances, smooth surfaces and significantly improved strength.

**The Ferulok Ferrules** – Ferulok fitting ferrules are precision machined with all dimensions and surfaces closely controlled, particularly the critical bite edge, which is monitored on an on-going basis. Ferrules are then heat-treated in a manner that provides the hardness, strength, and toughness necessary to satisfy the demanding service conditions that exist in industry today.

**The Ferulok Nuts** – Ferulok fitting nuts are either cold formed to size and shape, or machined from cold drawn material. The cold forming and cold drawing operations provide a more tightly packed grain structure, thus improving the material’s strength. In addition, cold forming significantly improves the fatigue or endurance strength of the nuts.

Ferulok Fittings	Steel		Stainless Steel	
	ASTM	Type	ASTM	Type
Cold Formed Bodies	A576	C1010/C1008	—	—
Forged Bodies	A576	1214/1215	A182	316
Bar Stock Bodies	A108	12L14	A479	316
Cold Formed Tube Nuts	A576	C1010	A479	316L
Bar Stock Tube Nuts	A108	12L14	A479	316
Tube Ferrules	A108	12L14	A564	630

Table D1 – Standard Material Specifications for Ferulok Fittings

**Note:** On request, Ferulok can be furnished in materials other than those shown above.

**Finish:** Zinc with yellow chromate (being changed to Zinc Chromium 6 Free) is used on all standard steel products.

Dimensions and pressures for reference only, subject to change.

## How Ferulok Fittings Work

As mentioned in the introduction, the ferrule in the Ferulok fitting forms pressure tight seals with the tube and the fitting body. These seals are the result of several key characteristics graphically shown in Fig. D2. Below are detailed explanations of each of these key features.

- A. When properly assembled, the wedging action of the Ferulok design will cause the end of the tube to press firmly against the seat in the body. This action will cause the tube to develop a small indentation circumferentially on the bottom of the tube. This indentation serves as a good post assembly inspection criterion.
- B. As the ferrule moves forward, it contacts the tapered seat of the body, which causes the ferrule to cam inward into the tube. The leading edge of the hardened ferrule makes a clean 360° cut into the outside diameter of the tube. This cut is often termed a “bite” and thus “bite type fitting”. As the ferrule makes its bite, a small ridge of material is plowed up in front of the ferrule. This intimate contact of the tube ridge with the ferrule’s front face and bite edge gives the fitting its ability to retain high pressure without leaking or blowing off. A second seal point is also created between the now bowed ferrule and the fitting body seat.
- C. As the ferrule bites into the tube, the mid section will bow and the inside diameter of the back area firmly grips the tube. This action keeps the stresses, caused by flexural and vibration loading, from being concentrated in the bite area. The “compression grip” at the back end is a key factor for long life in rigorous applications.

When properly assembled to the recommended tube, Ferulok fittings will consistently seal until the applied pressure is great enough to cause tube burst.

Although not as common, Ferulok fittings can be purchased without nuts and sleeves for use as a hose adapter (Fig. D3). Sealing occurs between the 24° cone of the fitting body and the hose swivel as shown.

## Assembly and Installation

Please refer to [Section T](#) for the assembly and installation instructions for Ferulok® fittings.

### Tube Recommendation

Maximum tube wall thickness is based on the pressure holding capability of Ferulok fittings. Tubes above the recommended range can be used. However, the pressure holding capability of the assembly will be limited to the fitting capacity. The proper Ferulok assembly procedures as outlined on [pages T23 - T26](#) of this catalog are critical to the performance of the fitting. Steel Ferulok works best with seamless or welded and drawn fully annealed tube, SAE J356, SAE J524, SAE J525 (max. hardness, RB72) or equivalent specification steel tube. For stainless steel Ferulok fittings, types 304 and 316 of ASTM A269, ASTM A213 (max. hardness, RB90) or equivalent stainless steel tube is recommended.

Ferulok fittings are also suitable for use with soft metal tube and various types of plastic tubes such as nylon, polyethylene, etc. When used with plastic tube, it is strongly recommended that a tube insert, such as T23UI, be used to prevent tube pull out due to tensile loading.

Consult the [Parker Hannifin Tube Fittings Division](#) for other combinations of tube and tube fitting materials not shown.

Dimensions and pressures for reference only, subject to change.

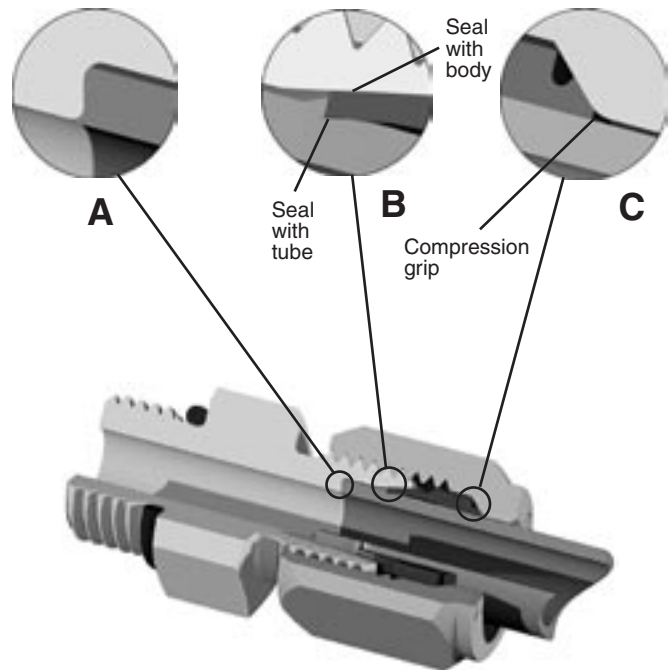

Fig. D2 – Assembled Ferulok Fitting with Tube

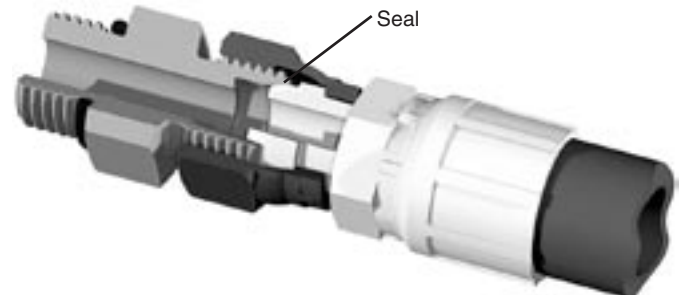

Fig. D3 – Ferulok Fitting with Hose Assembly

Size		Steel Stainless Steel	
O.D. Inches	Dash Number	Minimum Wall Thickness	Maximum Wall Thickness
1/8	-2	0.010	0.035
3/16	-3	0.020	0.049
1/4	-4	0.028	0.065
5/16	-5	0.028	0.065
3/8	-6	0.035	0.095
1/2	-8	0.049	0.120
5/8	-10	0.058	0.120
3/4	-12	0.065	0.120
7/8	-14	0.072	0.120
1	-16	0.083	0.148
1 1/4	-20	0.095	0.188
1 1/2	-24	0.095	0.220
2	-32	0.095	0.220

Table D2 — Recommended Tube Wall Thickness

Feature	Advantage	Benefit
Visible bite (Style A Ferrule)	Easy to inspect for assemblers	Saves time. Assures proper assembly.
	Quickly verify recommended bite was achieved	Eliminates the risk of catastrophic failure
Distributed stresses	Stresses due to service flexural loading are distributed at several points	Stress concentration at the bite is minimized; bite area of the tube is protected
Ferrule with rear bevel	Firmly grips tube	Dampens the effects of vibration in the joint
Tube wall range	Suitable for use with a wide range of wall thicknesses from medium to extra-heavy	Flexibility in design
		Covers wide range of applications
Remakeability	Joints can be disassembled and reassembled many times	Allows for system maintenance
		Saves money by not replacing fittings
Metal-to-metal seal	Service temperature rating is only limited to the materials chosen	Good choice for either high or relatively low temperature applications
No flaring or flanging required	Ease of assembly. No special equipment required for smaller sizes.	No assembly equipment cost for many users
		Ease of on-the-machine and remote area assembly and maintenance
Protected sealing surface	24° sealing cone is less prone to damage from handling, etc.	Better seal reliability

**Table D3 — Features, Advantages and Benefits of Using Ferulok Fittings**

Dimensions and pressures for reference only, subject to change.

# Ferulok Flareless Tube Ends

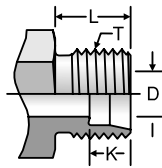

**Ferulok Male Stud Tube End**

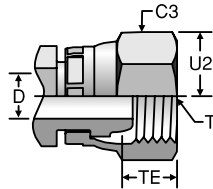

**Ferulok Swivel**

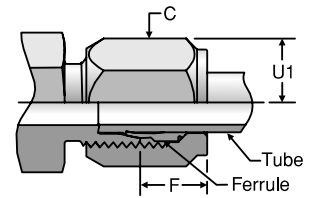

**Ferulok Tube End Assembly**

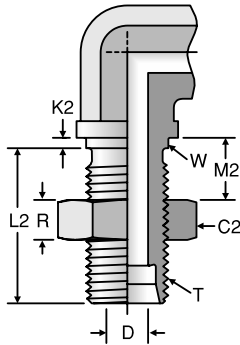

**Ferulok Shape Bulkhead**

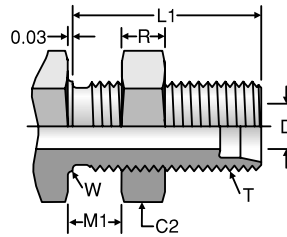

**Ferulok Straight Bulkhead**

SAE Dash Size	Tube O.D. (in.)	T UN/UNF	C (in.)	C2 (in.)	C3 (in.)	D (in)	Allowance		Male Turn Back (in)	Bulkhead					Max Bulkhead Thickness		Thread Engagement	Across Corners	
							F (in)	K (in)		Pilot Length Shapes (in)	Length - Straights (in)	Length - Shapes (in)	Locknut Thickness (in)	Pilot Dia (in)	Straights (in)	Shapes (in)		Tube Nut Hex (in)	Swivel Nut Hex (in)
2	1/8	5/16-24	3/8	9/16	7/16	0.093	0.31	0.19	0.375	0.09	1.02	0.83	0.22	0.31	0.28	0.38	0.22	0.22	0.25
3	3/16	3/8-24	7/16	5/8	1/2	0.125	0.34	0.24	0.422	0.09	1.06	0.88	0.22	0.37	0.28	0.38	0.25	0.25	0.29
4	1/4	7/16-20	9/16	11/16	9/16	0.203	0.42	0.24	0.453	0.09	1.13	0.94	0.28	0.44	0.28	0.38	0.29	0.33	0.33
5	5/16	1/2-20	5/8	3/4	5/8	0.234	0.42	0.26	0.453	0.09	1.12	0.94	0.28	0.50	0.28	0.38	0.31	0.36	0.36
6	3/8	9/16-18	11/16	13/16	11/16	0.281	0.47	0.26	0.469	0.09	1.17	0.98	0.27	0.56	0.31	0.41	0.34	0.40	0.40
8	1/2	3/4-16	7/8	1	7/8	0.422	0.50	0.31	0.562	0.13	1.31	1.12	0.31	0.75	0.31	0.41	0.32	0.51	0.51
10	5/8	7/8-14	1	1 1/8	1	0.500	0.53	0.36	0.625	0.13	1.45	1.27	0.36	0.88	0.38	0.44	0.37	0.58	0.59
12	3/4	1 1/16-12	1 1/4	1 3/8	1 1/4	0.656	0.56	0.36	0.688	0.13	1.56	1.38	0.41	1.06	0.38	0.44	0.42	0.72	0.73
14	7/8	1 3/16-12	1 3/8	1 1/2	1 3/8	0.719	0.53	0.36	0.688	0.13	1.56	1.38	0.41	1.19	0.38	0.44	0.34	0.79	0.79
16	1	1 5/16-12	1 1/2	1 5/8	1 1/2	0.875	0.66	0.42	0.688	0.13	1.56	1.38	0.41	1.31	0.38	0.44	0.32	0.87	0.88
20	1 1/4	1 5/8-12	2	1 7/8	2	1.093	0.72	0.42	0.688	0.13	1.56	1.38	0.41	1.62	0.38	0.44	0.33	1.15	1.17
24	1 1/2	1 7/8-12	2 1/4	2 1/8	2 1/4	1.344	0.72	0.49	0.688	0.13	1.56	1.38	0.41	1.87	0.38	0.44	0.34	1.30	1.29
32	2	2 1/2-12	2 7/8	2 3/4	2 7/8	1.813	0.84	0.49	0.688	0.13	1.77	1.58	0.41	2.50	0.56	0.63	0.34	1.66	1.64

1) Recommended clearance hole +0.015 over W dia.

Dimensions and pressures for reference only, subject to change.



**BU**  
Nut  
Flareless

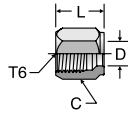

SAE 080110

TUBE FITTING PART #	TUBE O.D. (in.)	T6 UN/UNF-2B	C HEX (in.)	D DRILL (in.)	L (in.)	STANDARD MATERIAL FROM STOCK	
						-S	-SS
2 BU	1/8	5/16-24	3/8	0.130	0.53	•	•
3 BU	3/16	3/8-24	7/16	0.193	0.61	•	•
4 BU	1/4	7/16-20	9/16	0.255	0.70	•	•
5 BU	5/16	1/2-20	5/8	0.318	0.72	•	•
6 BU	3/8	9/16-18	11/16	0.380	0.75	•	•
8 BU	1/2	3/4-16	7/8	0.505	0.84	•	•
10 BU	5/8	7/8-14	1	0.631	0.92	•	•
12 BU	3/4	1 1/16-12	1 1/4	0.756	0.97	•	•
14 BU	7/8	1 3/16-12	1 3/8	0.881	1.00	•	•
16 BU	1	1 5/16-12	1 1/2	1.006	1.05	•	•
20 BU	1 1/4	1 5/8-12	2	1.260	1.05	•	•
24 BU	1 1/2	1 7/8-12	2 1/4	1.510	1.03	•	•
32 BU	2	2 1/2-12	2 7/8	2.014	1.12	•	•

**TU**  
Ferrule  
Flareless

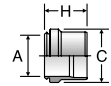

SAE 08115A

TUBE FITTING PART #	TUBE O.D. (in.)	A (in.)	C (in.)	H (in.)	STANDARD MATERIAL FROM STOCK	
					-S	-SS
2 TU	1/8	0.13	0.24	0.29	•	•
3 TU	3/16	0.19	0.31	0.33	•	•
4 TU	1/4	0.26	0.37	0.36	•	•
5 TU	5/16	0.32	0.43	0.37	•	•
6 TU	3/8	0.38	0.50	0.39	•	•
8 TU	1/2	0.51	0.66	0.43	•	•
10 TU	5/8	0.63	0.78	0.44	•	•
12 TU	3/4	0.76	0.93	0.48	•	•
14 TU	7/8	0.88	1.06	0.48	•	•
16 TU	1	1.01	1.19	0.48	•	•
20 TU	1 1/4	1.26	1.45	0.48	•	•
24 TU	1 1/2	1.51	1.69	0.48	•	•
32 TU	2	2.01	2.21	0.51	•	•

**WLN**  
Bulkhead Locknut  
Flareless

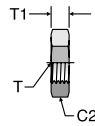

SAE 080118 and 070118

TUBE FITTING PART #	TUBE O.D. (in.)	T UN/UNF-2B	C2 HEX (in.)	L6 (in.)	STANDARD MATERIAL FROM STOCK	
					-S	-SS
3 WLN	3/16	3/8-24	5/8	0.22	•	•
4 WLN	1/4	7/16-20	11/16	0.28	•	•
5 WLN	5/16	1/2-20	3/4	0.28	•	•
6 WLN	3/8	9/16-18	13/16	0.27	•	•
8 WLN	1/2	3/4-16	1	0.31	•	•
10 WLN	5/8	7/8-14	1 1/8	0.36	•	•
12 WLN	3/4	1 1/16-12	1 3/8	0.41	•	•
14 WLN	7/8	1 3/16-12	1 1/2	0.41	•	•
16 WLN	1	1 5/16-12	1 5/8	0.41	•	•
20 WLN	1 1/4	1 5/8-12	1 7/8	0.41	•	•
24 WLN	1 1/2	1 7/8-12	2 1/8	0.41	•	•
32 WLN	2	2 1/2-12	2 3/4	0.41	•	•

**HBU**  
Union  
Flareless / Flareless

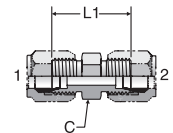

SAE 080101

TUBE FITTING PART #	END SIZE		C HEX (in.)	L1 (in.)	STANDARD Dynamic Pressure (x 1,000 PSI)	
	1 (in.)	2 (in.)			-S	-SS
	2 HBU	1/8				
3 HBU	3/16	3/16	7/16	1.11	6.0	6.0
4 HBU	1/4	1/4	1/2	1.19	6.0	6.0
5 HBU	5/16	5/16	9/16	1.19	6.0	6.0
6 HBU	3/8	3/8	5/8	1.24	6.0	6.0
6-4 HBU	3/8	1/4	5/8	1.22	6.0	6.0
8 HBU	1/2	1/2	13/16	1.42	5.0	5.0
10 HBU	5/8	5/8	15/16	1.61	5.0	5.0
12 HBU	3/4	3/4	1 1/8	1.81	4.5	4.5
14 HBU	7/8	7/8	1 1/4	1.81	4.0	4.0
16 HBU	1	1	1 3/8	1.81	4.0	4.0
20 HBU	1 1/4	1 1/4	1 11/16	1.89	3.0	3.0
24 HBU	1 1/2	1 1/2	2	1.96	2.0	2.0
32 HBU	2	2	2 5/8	2.11	1.5	1.5

Dimensions and pressures for reference only, subject to change.



### LHBU

Large Hex Union  
Flareless / Flareless

SAE 080119

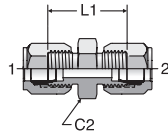

TUBE FITTING PART #	END SIZE		C2 HEX (in.)	L1 (in.)	STANDARD Dynamic Pressure (x 1,000 PSI)	
	1 (in.)	2 (in.)			-S	-SS
	4 LHBU	1/4			1/4	11/16
6 LHBU	3/8	3/8	13/16	1.23	6.0	6.0
6-4 LHBU	3/8	1/4	13/16	1.22		6.0
8 LHBU	1/2	1/2	1	1.42	5.0	5.0
8-6 LHBU	1/2	1/2	1	1.33		5.0
10 LHBU	5/8	5/8	1 1/8	1.61	5.0	
12 LHBU	3/4	3/4	1 3/8	1.81	4.5	4.5
16 LHBU	1	1	1 5/8	1.81	4.0	

### WBU

Bulkhead Union  
Flareless / Flareless

SAE 080601

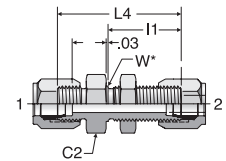

\* W – Bulkhead pilot dia. recommended clearance hole is +.015 over W dia.

TUBE FITTING PART #	END SIZE		C2 HEX (in.)	I1 (in.)	L4 (in.)	W (in.)	Max. Bulkhead Thickness	STANDARD Dynamic Pressure (x 1,000 PSI)	
	1 (in.)	2 (in.)						-S	-SS
	4 WBU	1/4						1/4	11/16
6 WBU	3/8	3/8	13/16	1.17	1.98	0.56	0.40	6.0	6.0
8 WBU	1/2	1/2	1	1.31	2.22	0.75	0.40	5.0	5.0
10 WBU	5/8	5/8	1 1/8	1.45	2.48	0.88	0.37	5.0	
12 WBU	3/4	3/4	1 3/8	1.56	2.72	1.06	0.43	4.5	4.5
16 WBU	1	1	1 5/8	1.56	2.72	1.31	0.43	4.0	

### F5BU

Straight Thread Connector  
Flareless / SAE-ORB

SAE 080120

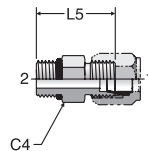

TUBE FITTING PART #	END SIZE		C4 HEX (in.)	L5 (in.)	STANDARD Dynamic Pressure (x 1,000 PSI)	
	1 (in.)	2 UN/UNF-2A			-S	-SS
	2 F5BU	1/8			5/16-24	7/16
3 F5BU	3/16	3/8-24	1/2	1.05	5.0	5.0
4 F5BU	1/4	7/16-20	9/16	1.13	5.0	5.0
4-5 F5BU	1/4	1/2-20	5/8	1.13	5.0	5.0
4-6 F5BU	1/4	9/16-18	11/16	1.20	5.0	5.0
4-10 F5BU	1/4	7/8-14	1	1.40		5.0
5 F5BU	5/16	1/2-20	5/8	1.13	5.0	
6 F5BU	3/8	9/16-18	11/16	1.22	5.0	5.0
6-4 F5BU	3/8	7/16-20	5/8	1.19		
6-8 F5BU	3/8	3/4-16	7/8	1.28	5.0	5.0
8 F5BU	1/2	3/4-16	7/8	1.38	5.0	5.0
8-6 F5BU	1/2	9/16-18	13/16	1.28	5.0	
8-10 F5BU	1/2	7/8-14	1	1.50	5.0	5.0
8-12 F5BU	1/2	1 1/16-12	1 1/4	1.67	4.5	4.5
10 F5BU	5/8	7/8-14	1	1.56	5.0	5.0
10-12 F5BU	5/8	1 1/16-12	1 1/4	1.73		
12 F5BU	3/4	1 1/16-12	1 1/4	1.78	4.5	4.5
12-8 F5BU	3/4	3/4-16	1 1/8	1.75	4.5	4.5
12-16 F5BU	3/4	1 5/16-12	1 1/2	1.81	4.0	
16 F5BU	1	1 5/16-12	1 1/2	1.81	4.0	4.0
16-12 F5BU	1	1 1/16-12	1 3/8	1.81	4.0	
16-20 F5BU	1	1 5/8-12	1 7/8	1.91	3.0	
20 F5BU	1 1/4	1 5/8-12	1 7/8	1.91	3.0	3.0
24 F5BU	1 1/2	1 7/8-12	2 1/8	1.97	3.0	3.0
32 F5BU	2	2 1/2-12	2 3/4	2.13	2.0	

### FBU

Male Connector  
Flareless / NPTF

SAE 080102

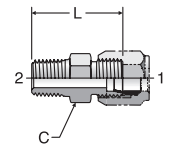

TUBE FITTING PART #	END SIZE		C HEX (in.)	L (in.)	STANDARD Dynamic Pressure (x 1,000 PSI)	
	1 (in.)	2 NPTF			-S	-SS
	2 FBU	1/8			1/8-27	7/16
2-4 FBU	1/8	1/4-18	9/16	1.24	5.0	5.0
3 FBU	3/16	1/8-27	7/16	1.09	5.0	5.0
4 FBU	1/4	1/8-27	1/2	1.12	5.0	5.0
4-4 FBU	1/4	1/4-18	9/16	1.32	5.0	5.0
4-6 FBU	1/4	3/8-18	3/4	1.33	5.0	5.0
4-8 FBU	1/4	1/2-14	7/8	1.58	5.0	5.0
5 FBU	5/16	1/8-27	9/16	1.12	5.0	5.0
5-4 FBU	5/16	1/4-18	9/16	1.32	5.0	5.0
6 FBU	3/8	1/4-18	5/8	1.34	5.0	5.0
6-2 FBU	3/8	1/8-27	5/8	1.15	5.0	5.0
6-6 FBU	3/8	3/8-18	3/4	1.35	5.0	5.0
6-8 FBU	3/8	1/2-14	15/16	1.60	5.0	5.0
8 FBU	1/2	3/8-18	13/16	1.44	5.0	5.0
8-4 FBU	1/2	1/4-18	13/16	1.44	5.0	5.0
8-8 FBU	1/2	1/2-14	7/8	1.69	5.0	5.0
8-12 FBU	1/2	3/4-14	1 1/8	1.76	4.0	4.0
10 FBU	5/8	1/2-14	15/16	1.75	4.5	4.5
10-6 FBU	5/8	3/8-18	15/16	1.56	4.5	4.5
10-12 FBU	5/8	3/4-14	1 1/8	1.82	4.0	4.0
12 FBU	3/4	3/4-14	1 1/8	1.88	4.0	4.0
12-8 FBU	3/4	1/2-14	1 1/8	1.88	4.0	4.0
14 FBU	7/8	3/4-14	1 1/4	1.88	3.0	
16 FBU	1	1-11 1/2	1 3/8	2.07	3.0	3.0
16-12 FBU	1	3/4-14	1 3/8	1.88	3.0	3.0
20 FBU	1 1/4	1 1/4-11 1/2	1 11/16	2.18	2.5	2.5
24 FBU	1 1/2	1 1/2-11 1/2	2	2.28	2.5	2.5
32 FBU	2	2-11 1/2	2 3/4	2.46	2.0	2.0

Dimensions and pressures for reference only, subject to change.

### GBU

Female Connector  
Flareless / NPTF

SAE 080103

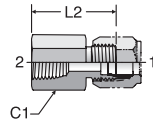

TUBE FITTING PART #	END SIZE		C1 HEX (in.)	L2 (in.)	STANDARD Dynamic Pressure (x 1,000 PSI)	
	1 (in.)	2 NPTF			-S	-SS
	2 GBU	1/8				
4 GBU	1/4	1/8-27	9/16	1.09	5.0	5.0
4-4 GBU	1/4	1/4-18	3/4	1.29	5.0	5.0
5 GBU	5/16	1/8-27	9/16	1.08	5.0	
6 GBU	3/8	1/4-18	3/4	1.31	5.0	5.0
6-6 GBU	3/8	3/8-18	7/8	1.34	5.0	5.0
6-8 GBU	3/8	1/2-14	1 1/8	1.59	5.0	5.0
8 GBU	1/2	3/8-18	7/8	1.47	5.0	5.0
8-4 GBU	1/2	1/4-18	7/8	1.46	5.0	5.0
8-8 GBU	1/2	1/2-14	1 1/8	1.69	5.0	5.0
10 GBU	5/8	1/2-14	1 1/8	1.77	4.5	4.5
12 GBU	3/4	3/4-14	1 3/8	1.89	4.0	4.0
14 GBU	7/8	3/4-14	1 3/8	1.86	3.0	
16 GBU	1	1-11 1/2	1 5/8	2.13	3.0	3.0
20 GBU	1 1/4	1 1/4-	2	2.22	2.5	
24 GBU	1 1/2	1 1/2-	2 3/8	2.23	2.5	

### TRBU

Tube End Reducer  
Tube / Flareless

SAE 080123

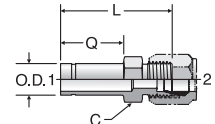

TUBE FITTING PART #	END SIZE		C HEX (in.)	L (in.)	Q (in.)	STANDARD Dynamic Pressure (x 1,000 PSI)	
	1 (in.)	2 (in.)				-S	-SS
	6-4 TRBU	3/8					
8-4 TRBU	1/2	1/4	9/16	1.73	1.00	5.0	5.0
8-6 TRBU	1/2	3/8	5/8	1.77	1.00	5.0	5.0
10-6 TRBU	5/8	3/8	11/16	1.86	1.09	5.0	
10-8 TRBU	5/8	1/2	13/16	1.95	1.09	4.5	4.5
12-6 TRBU	3/4	3/8	13/16	1.94	1.16	4.5	4.5
12-8 TRBU	3/4	1/2	13/16	2.03	1.16	4.5	4.5
12-10 TRBU	3/4	5/8	15/16	2.16	1.16	4.5	
14-10 TRBU	7/8	5/8	15/16	2.14	1.16	4.0	
16-8 TRBU	1	1/2	1 1/16	2.05	1.13	4.0	4.0
16-10 TRBU	1	5/8	1 1/16	2.11	1.13	4.0	
16-12 TRBU	1	3/4	1 1/8	2.25	1.13	4.0	4.0
20-16 TRBU	1 1/4	1	1 3/8	2.28	1.16	3.0	
24-12 TRBU	1 1/2	3/4	1 5/8	2.45	1.25	2.0	
24-16 TRBU	1 1/2	1	1 5/8	2.45	1.25	2.0	
24-20 TRBU	1 1/2	1 1/4	1 7/8	2.45	1.25	2.0	

### V5BU

45° Straight Thread Elbow  
Flareless / SAE-ORB

SAE 080320

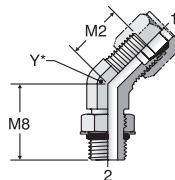

\* Y – Across wrench flats

TUBE FITTING PART #	END SIZE		M2 (in.)	M8 (in.)	Y (in.)	STANDARD Dynamic Pressure (x 1,000 PSI)	
	1 (in.)	2 UN/UNF-2A				-S	-SS
	4 V5BU	1/4					
6 V5BU	3/8	9/16-18	0.83	1.14	9/16	5.0	5.0
8 V5BU	1/2	3/4-16	0.98	1.30	3/4	5.0	
12 V5BU	3/4	1 1/16-12	1.27	1.73	1 1/16	4.0	
16 V5BU	1	1 5/16-12	1.36	1.86	1 5/16	3.0	

### VBU

45° Male Elbow  
Flareless / NPTF

SAE 080302

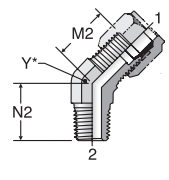

\* Y – Across wrench flats

TUBE FITTING PART #	END SIZE		M2 (in.)	N2 (in.)	Y (in.)	STANDARD Dynamic Pressure (x 1,000 PSI)	
	1 (in.)	2 NPTF				-S	-SS
	3 VBU	3/16					
4 VBU	1/4	1/8-27	0.70	0.64	7/16	5.0	5.0
4-4 VBU	1/4	1/4-18	0.81	0.86	9/16	5.0	
5 VBU	5/16	1/8-27	0.75	0.66	9/16	5.0	
6 VBU	3/8	1/4-18	0.83	0.86	9/16	5.0	5.0
8 VBU	1/2	3/8-18	0.98	0.95	3/4	5.0	5.0
10 VBU	5/8	1/2-14	1.08	1.17	7/8	4.5	4.5
12 VBU	3/4	3/4-14	1.27	1.20	1 1/16	4.0	
14 VBU	7/8	3/4-14	1.34	1.30	1 5/16	3.0	
16 VBU	1	1-11 1/2	1.36	1.48	1 5/16	3.0	
20 VBU	1 1/4	1 1/4-11 1/2	1.45	1.67	1 5/8	2.5	

Dimensions and pressures for reference only, subject to change.



### EBU

Union Elbow  
Flareless / Flareless

SAE 080201

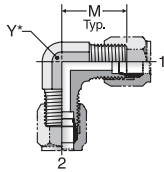

\* Y – Across wrench flats

TUBE FITTING PART #	END SIZE		M (in.)	Y (in.)	STANDARD Dynamic Pressure (x 1,000 PSI)	
	1 (in.)	2 (in.)			-S	-SS
	2 EBU	1/8				
4 EBU	1/4	1/4	0.89	7/16	5.0	5.0
5 EBU	5/16	5/16	0.95	9/16	5.0	
6 EBU	3/8	3/8	1.05	9/16	5.0	5.0
8 EBU	1/2	1/2	1.25	3/4	5.0	5.0
10 EBU	5/8	5/8	1.42	7/8	4.5	4.5
12 EBU	3/4	3/4	1.58	1 1/16	4.0	4.0
14 EBU	7/8	7/8	1.66	1 5/16	3.0	
16 EBU	1	1	1.73	1 5/16	3.0	3.0
20 EBU	1 1/4	1 1/4	1.89	1 5/8	2.5	
24 EBU	1 1/2	1 1/2	2.02	1 7/8	2.0	2.0
32 EBU	2	2	2.45	2 1/2	1.5	

### WEBU

Bulkhead Union Elbow  
Flareless / Flareless Bulkhead

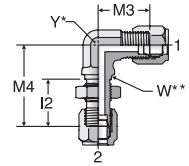

\* Y – Across wrench flats.  
W\*\* – Bulkhead pilot dia. recommended clearance hole is +.015 over W dia.

TUBE FITTING PART #	END SIZE		I2 (in.)	M3 (in.)	M4 (in.)	W DIA (in.)	Y (in.)	Max. Bulkhead Thickness	STANDARD Dynamic Pressure (x 1,000 PSI)	
	1 (in.)	2 (in.)							-S	-SS
	6 WEBU	3/8								
8 WEBU	1/2	1/2	1.12	1.33	1.97	0.75	3/4	0.30	5.0	

### C6BU

Swivel Nut Elbow  
Flareless / Flareless Swivel

SAE 080221

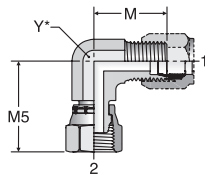

\* Y – Across wrench flats

TUBE FITTING PART #	END SIZE		M (in.)	M5 (in.)	Y (in.)	STANDARD Dynamic Pressure (x 1,000 PSI)	
	1 (in.)	2 (in.)				-S	-SS
	4 C6BU	1/4					
6 C6BU	3/8	3/8	1.05	1.25	9/16	5.0	5.0
8 C6BU	1/2	1/2	1.25	1.38	3/4	5.0	5.0
10 C6BU	5/8	5/8	1.42	1.62	7/8	4.5	
12 C6BU	3/4	3/4	1.58	1.75	1 1/16	4.0	4.0
16 C6BU	1	1	1.73	2.00	1 5/16	3.0	
20 C6BU	1 1/4	1 1/4	1.89	2.31	1 5/8	2.5	

### C5BU

Straight Thread Elbow  
Flareless / SAE-ORB

SAE 080220

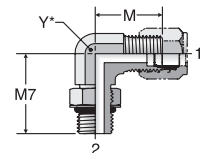

\* Y – Across wrench flats

TUBE FITTING PART #	END SIZE		M (in.)	M7 (in.)	Y (in.)	STANDARD Dynamic Pressure (x 1,000 PSI)	
	1 (in.)	2 UN/UNF-2A				-S	-SS
	3 C5BU	3/16					
4 C5BU	1/4	7/16-20	0.89	1.03	7/16	5.0	5.0
5 C5BU	5/16	1/2-20	0.95	1.13	9/16	5.0	5.0
6 C5BU	3/8	9/16-18	1.05	1.25	9/16	5.0	5.0
6-8 C5BU	3/8	3/4-16	1.14	1.45	3/4	5.0	
8 C5BU	1/2	3/4-16	1.25	1.45	3/4	5.0	5.0
8-6 C5BU	1/2	9/16-18	1.27	1.33	3/4	5.0	
8-10 C5BU	1/2	7/8-14	1.34	1.70	7/8	4.5	
8-12 C5BU	1/2	1 1/16-12	1.43	1.94	1 1/16	4.0	
10 C5BU	5/8	7/8-14	1.42	1.70	7/8	4.5	4.5
12 C5BU	3/4	1 1/16-12	1.58	1.94	1 1/16	4.0	4.0
12-8 C5BU	3/4	3/4-16	1.58	1.63	1 1/16	4.0	
12-10 C5BU	3/4	7/8-14	1.58	1.78	1 1/16	4.0	
12-16 C5BU	3/4	1 5/16-12	1.73	2.05	1 5/16		
16 C5BU	1	1 5/16-12	1.73	2.05	1 5/16	3.0	3.0
16-12 C5BU	1	1 1/16-12	1.73	2.05	1 5/16	3.0	
20 C5BU	1 1/4	1 5/8-12	1.89	2.25	1 5/8	2.5	
24 C5BU	1 1/2	1 7/8-12	2.02	2.39	1 7/8	2.0	2.0
32 C5BU	2	2 1/2-12	2.45	2.89	2 1/2	1.5	

Dimensions and pressures for reference only, subject to change.



### CC5BU

Straight Thread Elbow  
Flareless / SAE-ORB Long

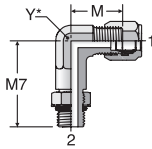

\* Y – Across wrench flats

TUBE FITTING PART #	END SIZE		M (in.)	M7 (in.)	Y (in.)	STANDARD Dynamic Pressure (x 1,000 PSI)	
	1 (in.)	2 UN/UNF-2A				-S	-SS
	4 CC5BU	1/4					
6 CC5BU	3/8	9/16-18	1.05	1.72	9/16	5.0	
8 CC5BU	1/2	3/4-16	1.25	2.02	3/4	5.0	
10 CC5BU	5/8	7/8-14	1.42	2.39	7/8	4.5	
12 CC5BU	3/4	1 1/16-12	1.58	2.69	1 1/16	4.0	
16 CC5BU	1	1 5/16-12	1.73	3.13	1 5/16	3.0	

### CBU

Male Elbow  
Flareless / NPTF

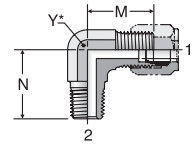

\* Y – Across wrench flats

TUBE FITTING PART #	END SIZE		M (in.)	N (in.)	Y (in.)	STANDARD Dynamic Pressure (x 1,000 PSI)	
	1 (in.)	2 NPTF				-S	-SS
	2 CBU	1/8					
3 CBU	3/16	1/8-27	0.83	0.72	7/16	5.0	5.0
4 CBU	1/4	1/8-27	0.89	0.78	7/16	5.0	5.0
4-4 CBU	1/4	1/4-18	1.03	1.09	9/16	5.0	5.0
4-6 CBU	1/4	3/8-18	1.12	1.22	3/4	5.0	5.0
5 CBU	5/16	1/8-27	0.95	0.81	9/16	5.0	5.0
5-4 CBU	5/16	1/4-18	1.03	1.09	9/16	5.0	5.0
6 CBU	3/8	1/4-18	1.05	1.09	9/16	5.0	5.0
6-2 CBU	3/8	1/8-27	1.05	0.90	9/16	5.0	5.0
6-6 CBU	3/8	3/8-18	1.14	1.22	3/4	5.0	5.0
6-8 CBU	3/8	1/2-14	1.24	1.47	7/8	5.0	5.0
8 CBU	1/2	3/8-18	1.25	1.22	3/4	5.0	5.0
8-4 CBU	1/2	1/4-18	1.25	1.16	3/4	5.0	5.0
8-8 CBU	1/2	1/2-14	1.35	1.47	7/8	5.0	5.0
8-12 CBU	1/2	3/4-14	1.43	1.59	1 1/16	4.0	
10 CBU	5/8	1/2-14	1.42	1.47	7/8	4.5	4.5
10-6 CBU	5/8	3/8-18	1.42	1.28	7/8	4.5	
12 CBU	3/4	3/4-14	1.58	1.59	1 1/16	4.0	4.0
12-8 CBU	3/4	1/2-14	1.58	1.59	1 1/16	4.0	4.0
14 CBU	7/8	3/4-14	1.66	1.69	1 5/16	3.0	
16 CBU	1	1-11 1/2	1.73	1.97	1 5/16	3.0	3.0
16-12 CBU	1	3/4-14	1.73	1.78	1 5/16	3.0	3.0
20 CBU	1 1/4	1 1/4-11 1/2	1.89	2.38	1 5/8	2.5	2.5
24 CBU	1 1/2	1 1/2-11 1/2	2.02	2.64	1 7/8	2.5	2.5
32 CBU	2	2-11 1/2	2.45	3.00	2 1/2	2.0	

### DBU

Female Elbow  
Flareless / NPTF

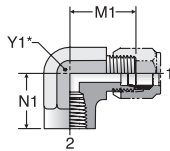

\* Y1 – Across wrench flats

SAE 080203

TUBE FITTING PART #	END SIZE		M1 (in.)	N1 (in.)	Y1 (in.)	STANDARD Dynamic Pressure (x 1,000 PSI)	
	1 (in.)	2 NPTF				-S	-SS
	4 DBU	1/4					
4-4 DBU	1/4	1/4-18	1.03	0.88	3/4	5.0	5.0
5 DBU	5/16	1/8-27	0.95	0.66	9/16	5.0	
6 DBU	3/8	1/4-18	1.05	0.88	3/4	5.0	5.0
6-6 DBU	3/8	3/8-18	1.13	1.02	7/8	4.5	4.5
8 DBU	1/2	3/8-18	1.23	1.02	7/8	3.0	3.0
8-4 DBU	1/2	1/4-18	1.23	0.88	3/4	5.0	5.0
8-8 DBU	1/2	1/2-14	1.34	1.23	1 1/16	3.0	3.0
10 DBU	5/8	1/2-14	1.42	1.23	1 1/16	3.0	3.0
12 DBU	3/4	3/4-14	1.58	1.36	1 5/16	3.0	3.0
14 DBU	7/8	3/4-14	1.62	1.42	1 5/16	3.0	
16 DBU	1	1-11 1/2	1.73	1.63	1 5/8	1.7	
20 DBU	1 1/4	1 1/4-11 1/2	2.08	1.70	1 7/8	1.5	
24 DBU	1 1/2	1 1/2-11 1/2	2.58	2.08	2 1/2	1.0	

Dimensions and pressures for reference only, subject to change.

### JBU

Union Tee  
Flareless (all three ends)

SAE 080401

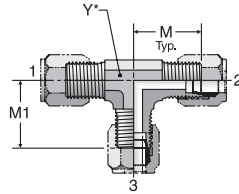

\* Y – Across wrench flats

TUBE FITTING PART #	END SIZE			M (in.)	M1 (in.)	Y (in.)	STANDARD Dynamic Pressure (x 1,000 PSI)	
	1 (in.)	2 (in.)	3 (in.)				-S	-SS
2 JBU	1/8	1/8	1/8	0.77	0.77	7/16	5.0	
3 JBU	3/16	3/16	3/16	0.84	0.84	7/16	5.0	
4 JBU	1/4	1/4	1/4	0.89	0.89	7/16	5.0	5.0
5 JBU	5/16	5/16	5/16	0.95	0.95	9/16	5.0	5.0
6 JBU	3/8	3/8	3/8	1.05	1.05	9/16	5.0	5.0
8 JBU	1/2	1/2	1/2	1.25	1.25	3/4	5.0	5.0
8-8-6 JBU	1/2	1/2	3/8	1.25	1.14	3/4	5.0	
10 JBU	5/8	5/8	5/8	1.42	1.42	7/8	4.5	4.5
12 JBU	3/4	3/4	3/4	1.58	1.58	1 1/16	4.0	4.0
14 JBU	7/8	7/8	7/8	1.66	1.66	1 5/16	3.0	
16 JBU	1	1	1	1.73	1.73	1 5/16	3.0	3.0
20 JBU	1 1/4	1 1/4	1 1/4	1.89	1.89	1 5/8	2.5	2.5
24 JBU	1 1/2	1 1/2	1 1/2	2.02	2.02	1 7/8	2.0	2.0

### S6BU

Swivel Nut Branch Tee  
Flareless / Flareless Swivel

SAE 080202

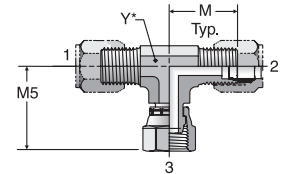

\* Y – Across wrench flats

TUBE FITTING PART #	END SIZE			M (in.)	M5 (in.)	Y (in.)	STANDARD Dynamic Pressure (x 1,000 PSI)	
	1 (in.)	2 (in.)	3 (in.)				-S	-SS
4 S6BU	1/4	1/4	1/4	0.89	1.00	7/16	5.0	5.0
6 S6BU	3/8	3/8	3/8	1.05	1.25	9/16	5.0	5.0
8 S6BU	1/2	1/2	1/2	1.25	1.38	3/4	5.0	5.0
12 S6BU	3/4	3/4	3/4	1.58	1.75	1 1/16	4.0	4.0

### R6BU

Swivel Nut Run Tee  
Flareless / Flareless Swivel

SAE 080432

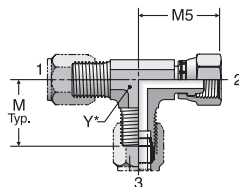

\* Y – Across wrench flats

TUBE FITTING PART #	END SIZE			M (in.)	M5 (in.)	Y (in.)	STANDARD Dynamic Pressure (x 1,000 PSI)	
	1 (in.)	2 (in.)	3 (in.)				-S	-SS
4 R6BU	1/4	1/4	1/4	0.89	1.00	7/16	5.0	5.0
6 R6BU	3/8	3/8	3/8	1.05	1.25	9/16	5.0	5.0
8 R6BU	1/2	1/2	1/2	1.25	1.38	3/4	5.0	5.0
12 R6BU	3/4	3/4	3/4	1.58	1.75	1 1/16	4.0	4.0
16 R6BU	1	1	1	1.73	2.00	1 5/16	3.0	

### S5BU

Straight Thread Branch Tee  
Flareless / SAE-ORB

SAE 080429

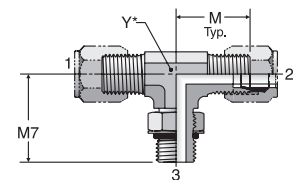

\* Y – Across wrench flats

TUBE FITTING PART #	END SIZE			M (in.)	M7 (in.)	Y (in.)	STANDARD Dynamic Pressure (x 1,000 PSI)	
	1 (in.)	2 (in.)	3 UN/UNF-2A				-S	-SS
4 S5BU	1/4	1/4	7/16-20	0.89	1.03	7/16	5.0	5.0
6 S5BU	3/8	3/8	9/16-18	1.05	1.25	9/16	5.0	5.0
8 S5BU	1/2	1/2	3/4-16	1.25	1.45	3/4	5.0	5.0
12 S5BU	3/4	3/4	1 1/16-12	1.58	1.94	1 1/16	4.0	4.0
16 S5BU	1	1	1 5/16-12	1.73	2.05	1 5/16	3.0	

Dimensions and pressures for reference only, subject to change.

### R5BU

Straight Thread Run Tee  
Flareless / SAE-ORB

SAE 080428

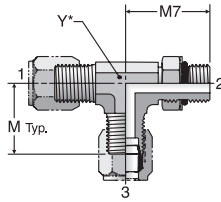

\*Y – Across wrench flats

TUBE FITTING PART #	END SIZE			M (in.)	M7 (in.)	Y (in.)	STANDARD Dynamic Pressure (x 1,000 PSI)	
	1 (in.)	2 UN/UNF-2A	3 (in.)				-S	-SS
	4 R5BU	1/4	7/16-20					
6 R5BU	3/8	9/16-18	3/8	1.05	1.25	9/16	5.0	5.0
8 R5BU	1/2	3/4-16	1/2	1.25	1.45	3/4	5.0	5.0
10 R5BU	5/8	7/8-14	5/8	1.42	1.70	7/8	4.5	
12 R5BU	3/4	1 1/16-12	3/4	1.58	1.94	1 1/16	4.0	4.0
16 R5BU	1	1 5/16-12	1	1.73	2.05	1 5/16	3.0	

### SBU

Male Branch Tee  
Flareless / NPTF

SAE 080425

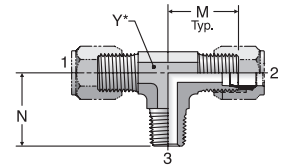

\*Y – Across wrench flats

TUBE FITTING PART #	END SIZE			M (in.)	N (in.)	Y (in.)	STANDARD Dynamic Pressure (x 1,000 PSI)	
	1 (in.)	2 (in.)	3 NPTF				-S	-SS
	2 SBU	1/8	1/8					
4 SBU	1/4	1/4	1/8-27	0.89	0.78	7/16	5.0	5.0
4-4-4 SBU	1/4	1/4	1/4-18	1.03	1.09	9/16	5.0	5.0
5 SBU	5/16	5/16	1/8-27	0.95	0.81	9/16	5.0	
6 SBU	3/8	3/8	1/4-18	1.05	1.09	9/16	5.0	5.0
8 SBU	1/2	1/2	3/8-18	1.25	1.22	3/4	5.0	5.0
8-8-8 SBU	1/2	1/2	1/2-14	1.35	1.47	7/8	5.0	5.0
10 SBU	5/8	5/8	1/2-14	1.42	1.47	7/8	4.5	
12 SBU	3/4	3/4	3/4-14	1.58	1.59	1 1/16	4.0	4.0
14 SBU	7/8	7/8	3/4-14	1.66	1.69	1 5/16	3.0	
16 SBU	1	1	1-11 1/2	1.73	1.97	1 5/16	3.0	3.0

### RBU

Male Run Tee  
Flareless / NPTF

SAE 080424

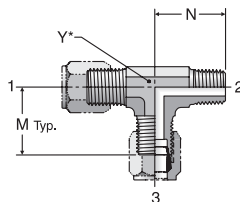

\*Y – Across wrench flats

TUBE FITTING PART #	END SIZE			M (in.)	N (in.)	Y (in.)	STANDARD Dynamic Pressure (x 1,000 PSI)	
	1 (in.)	2 NPTF	3 (in.)				-S	-SS
	4 RBU	1/4	1/8-27					
4-4-4 RBU	1/4	1/4-18	1/4	1.03	1.09	9/16	5.0	5.0
5 RBU	5/16	1/8-27	5/16	0.95	0.81	9/16	5.0	
6 RBU	3/8	1/4-18	3/8	1.05	1.09	9/16	5.0	5.0
8 RBU	1/2	3/8-18	1/2	1.25	1.22	3/4	5.0	
8-8-8 RBU	1/2	1/2-14	1/2	1.34	1.47	7/8	5.0	5.0
10 RBU	5/8	1/2-14	5/8	1.42	1.47	7/8	4.5	
12 RBU	3/4	3/4-14	3/4	1.58	1.59	1 1/16	4.0	4.0
14 RBU	7/8	3/4-14	7/8	1.62	1.69	1 5/16	3.0	
16 RBU	1	1-11 1/2	1	1.73	1.97	1 5/16	3.0	

### OBU

Female Branch Tee  
Flareless / NPTF

SAE 080427

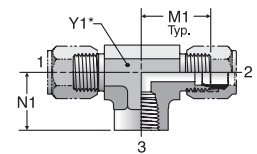

\*Y1 – Across wrench flats

TUBE FITTING PART #	END SIZE			M1 (in.)	N1 (in.)	Y1 (in.)	STANDARD Dynamic Pressure (x 1,000 PSI)	
	1 (in.)	2 (in.)	3 NPTF				-S	-SS
	4 OBU	1/4	1/4					
4-4-4 OBU	1/4	1/4	1/4-18	1.03	0.88	3/4	5.0	5.0
6 OBU	3/8	3/8	1/4-18	1.05	0.88	3/4	5.0	5.0
8 OBU	1/2	1/2	3/8-18	1.23	1.02	7/8	3.0	3.0
10 OBU	5/8	5/8	1/2-14	1.42	1.23	1 1/16	3.0	
12 OBU	3/4	3/4	3/4-14	1.58	1.36	1 5/16	3.0	
14 OBU	7/8	7/8	3/4-14	1.62	1.42	1 5/16	3.0	
16 OBU	1	1	1-11 1/2	1.73	1.62	1 5/8	1.7	
20 OBU	1 1/4	1 1/4	1 1/4-11 1/2	2.08	1.70	1 7/8	1.5	

Dimensions and pressures for reference only, subject to change.

### MBU

Female Run Tee  
Flareless / NPTF

SAE 080426

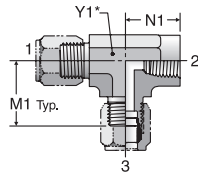

\* Y1 – Across wrench flats

TUBE FITTING PART #	END SIZE			M1 (in.)	N1 (in.)	Y1 (in.)	STANDARD Dynamic Pressure (x 1,000 PSI)	
	1 (in.)	2 NPTF	3 (in.)				-S	-SS
4 MBU	1/4	1/8-27	1/4	0.89	0.66	9/16	5.0	
6 MBU	3/8	1/4-18	3/8	1.05	0.88	3/4	5.0	
8 MBU	1/2	3/8-18	1/2	1.23	1.02	7/8	3.0	
10 MBU	5/8	1/2-14	5/8	1.42	1.23	1 1/16	3.0	
12 MBU	3/4	3/4-14	3/4	1.58	1.36	1 5/16	3.0	
16 MBU	1	1-11 1/2	1	1.73	1.62	1 5/8	1.7	

### KBU

Union Cross  
Flareless (all four ends)

SAE 080501

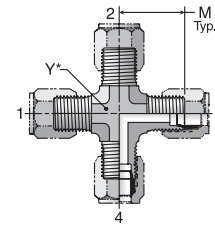

\* Y – Across wrench flats

TUBE FITTING PART #	END SIZE 1-4 (in.)	M (in.)	Y (in.)	STANDARD Dynamic Pressure (x 1,000 PSI)	
				-S	-SS
4 KBU	1/4	0.89	7/16	5.0	5.0
6 KBU	3/8	1.05	9/16	5.0	5.0
8 KBU	1/2	1.25	3/4	5.0	5.0
12 KBU	3/4	1.58	1 1/16	4.0	

### PNU

Plug  
Flareless

SAE 080109

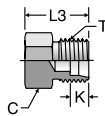

TUBE FITTING PART #	TUBE O.D. (in.)	T TUBE END UN/UNF-2A	C HEX (in.)	K (in.)	L3 (in.)	STANDARD Dynamic Pressure (x 1,000 PSI)	
						-S	-SS
2 PNU	1/8	5/16-24	7/16	0.19	0.63	6.0	
4 PNU	1/4	7/16-20	1/2	0.24	0.72	6.0	6.0
5 PNU	5/16	1/2-20	9/16	0.26	0.72	6.0	
6 PNU	3/8	9/16-18	5/8	0.26	0.75	6.0	6.0
8 PNU	1/2	3/4-16	13/16	0.31	0.84	5.0	5.0
10 PNU	5/8	7/8-14	15/16	0.36	0.97	5.0	
12 PNU	3/4	1 1/16-12	1 1/8	0.36	1.09	4.5	4.5
16 PNU	1	1 5/16-12	1 3/8	0.42	1.09	4.0	

### FNU

Cap  
Flareless Swivel

SAE 080112

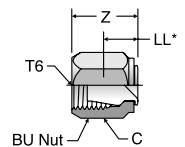

\* LL – Fitting end to rear of plug

TUBE FITTING PART #	TUBE O.D. (in.)	T6 UN/UNF-2B	C HEX (in.)	LL (in.)	Z (in.)	STANDARD Dynamic Pressure (x 1,000 PSI)	
						-S	-SS
2 FNU	1/8	5/16-24	3/8	0.34	0.55		6.0
4 FNU	1/4	7/16-20	9/16	0.36	0.73	6.0	6.0
5 FNU	5/16	1/2-20	5/8	0.40	0.77	6.0	
6 FNU	3/8	9/16-18	11/16	0.42	0.80	6.0	6.0
8 FNU	1/2	3/4-16	7/8	0.44	0.87	5.0	5.0
10 FNU	5/8	7/8-14	1	0.47	0.98	5.0	5.0
12 FNU	3/4	1 1/16-12	1 1/4	0.48	1.00	4.5	4.5
16 FNU	1	1 5/16-12	1 1/2	0.58	1.08	4.0	4.0
20 FNU	1 1/4	1 5/8-12	2	0.64	1.11	3.0	

Dimensions and pressures for reference only, subject to change.



