

Tow-Pro Wiring Kit

Fitting Instructions

Suitable for: Mitsubishi Triton

Kit Part No: TPWKIT-003

Accessory Kit

Estimated Fitting Time: 90 Minutes

General Notes











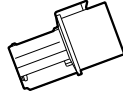
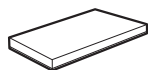

- Read through the fitting instructions before installation of the accessory. Install the accessory following the fitting instructions. Failure to do so may cause damage to the vehicle or the accessory.
- Ensure all recyclables, discarded vehicle accessory components and packaging are recycled following local recycling regulations.
- It is always recommended that this accessory is fitted by a qualified automotive Technician.
- Safely store and protect any removed vehicle components.
- Ensure all bare metal surfaces are protected using automotive bare metal primer and touch-up paint, or suitable automotive rust inhibitor.
- Remove all metals swarf and dust from all vehicle surfaces if surfaces is used for accessory installation.

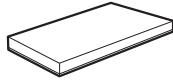
Safety Notes

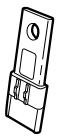
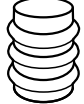
- Check that all work practices comply with safety standards.
- Please wear appropriate clothing and use safety equipment.

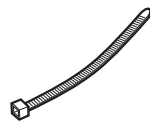
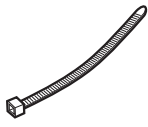
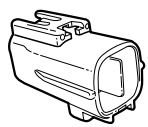
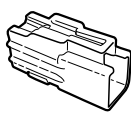
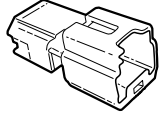

Parts Supplied

<p>A</p>  <p>Engine Bay Harness x1</p>	<p>B</p>  <p>Kick Panel Harness x1</p>	<p>C</p>  <p>Brake Signal Harness x1</p>	<p>D</p>  <p>3-Way Male Connector x1</p>	<p>E</p>  <p>60X30X3mm Foam Tape x1</p>	<p>F</p>  <p>M6 Nyloc Nut x1</p>
<p>G</p>  <p>100X40X3mm Foam Tape x1</p>	<p>H</p>  <p>M4 Nyloc Nut x4</p>	<p>I</p>  <p>M4 Flat Washer x4</p>	<p>J</p>  <p>Secondary Lock x1</p>	<p>K</p>  <p>Plug Seal x5</p>	<p>L</p>  <p>Switch Insert x1</p>
<p>M</p>  <p>M6 Flat Washer x1</p>	<p>N</p>  <p>1.5m CAT 5 Cable x1</p>	<p>O</p>  <p>Bracket x1</p>	<p>P</p>  <p>200mm Cable Ties x16</p>	<p>Q</p>  <p>900mm Cable Ties x8</p>	<p>R</p>  <p>4-Way Male Connector x1</p>
<p>S</p>  <p>4-Way Male Connector x1</p>	<p>T</p>  <p>3-Way Male Connector x1</p>	<p>U</p>  <p>Fitting Instructions x1</p>			

Tools Required

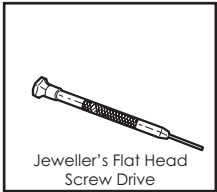
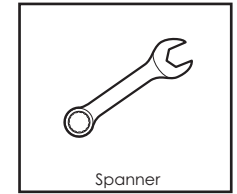
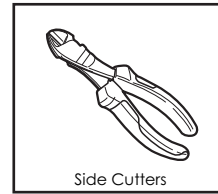
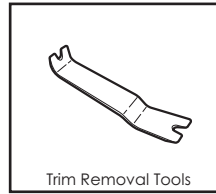
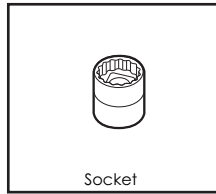
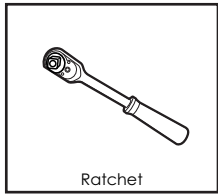
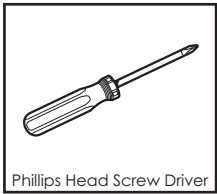

— Wiring Diagram —

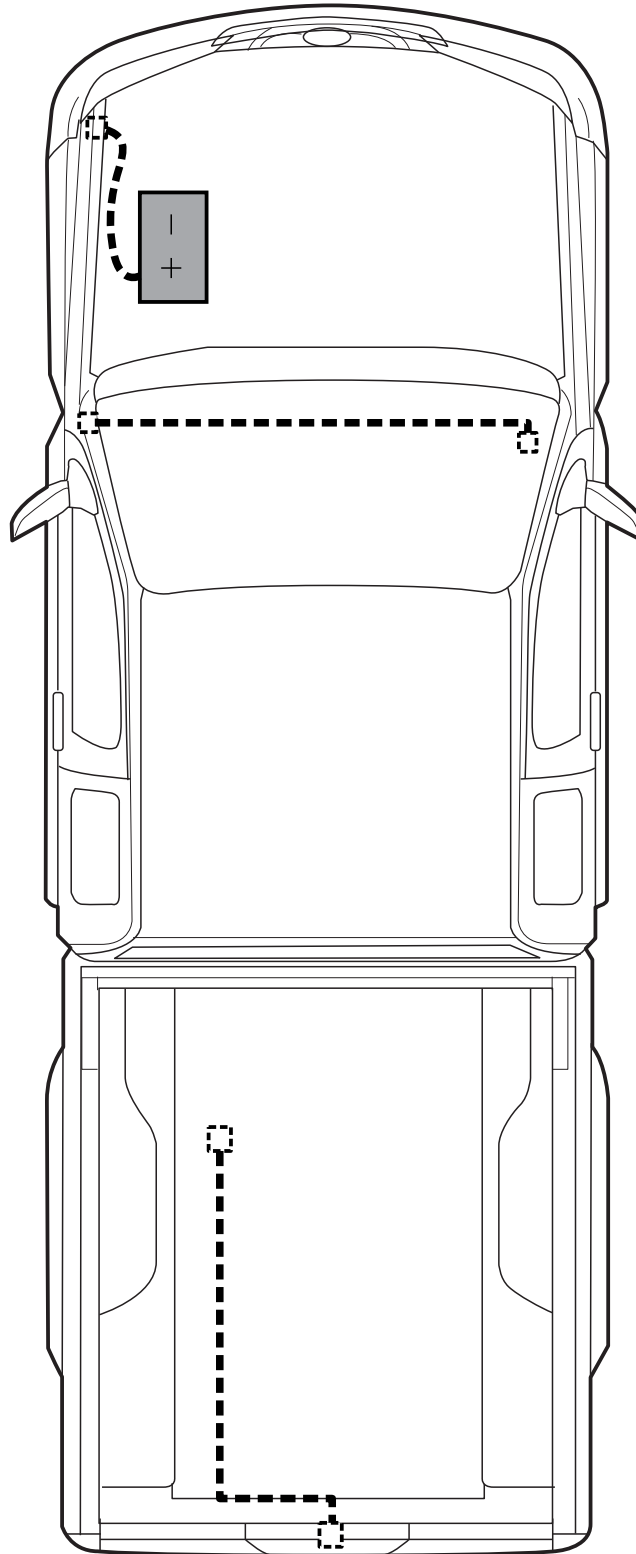

Step 1

Important



Always refer to the vehicle's Workshop Manual when removing vehicle components.

- Note down all clock and radio settings.
- In the engine bay, disconnect the negative battery terminal (1).

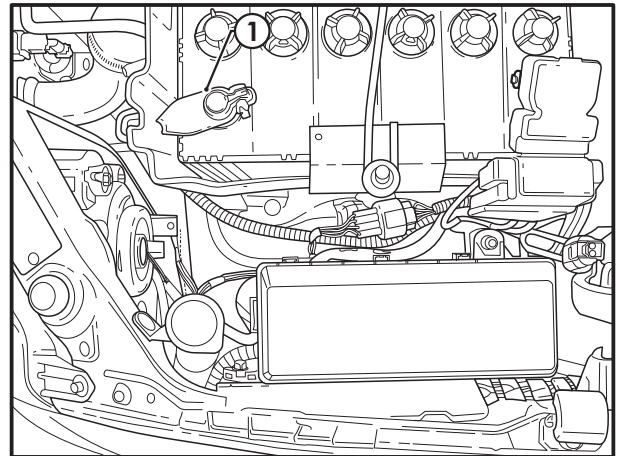

Step 2

- Secure the Engine Bay Harness ring terminal (1) to the positive battery terminal (2), ensuring the ring terminal wire is routed underneath the battery cap.

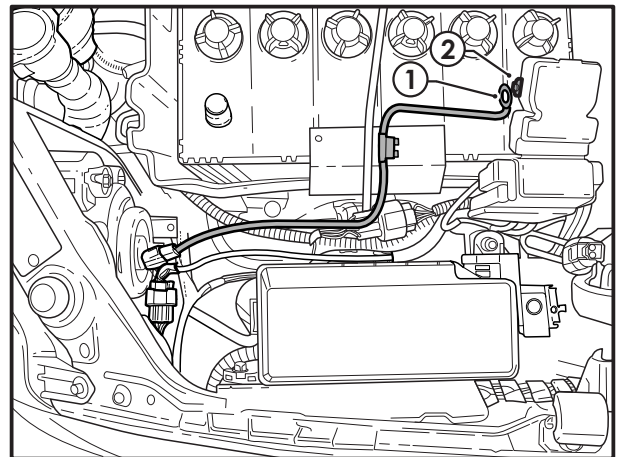

Step 3

- Locate the 4-way connector at the rear of the LHS head light.
- Disconnect and discard the blanking plug from the 4-way connector.
- Install the Engine Bay Harness (1) black wire terminal into position 1 of the supplied mating 4-way Male Connector, then insert the supplied Plug Seals into the remaining cavities.

Note: If the vehicle is fitted with a Trailer Wiring Harness, then use the existing 4-way connector. Remove the plug seal and house the black wire terminal in position 1.

- Connect the Engine Bay Harness (1) to the vehicle head light 4-way connector (2).

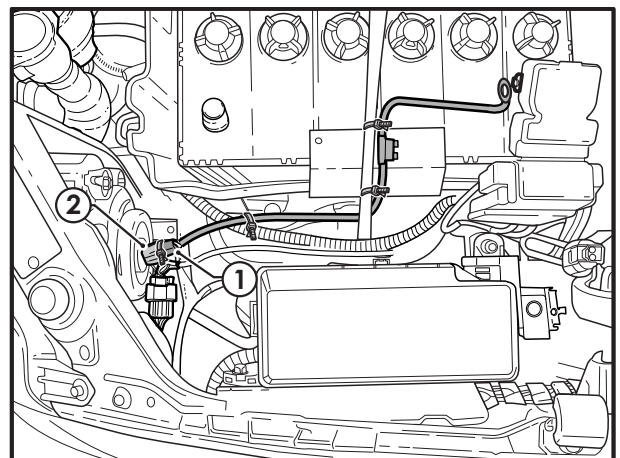

Note: The colour of the wire on the vehicle-side of the terminal must match the wire colour on the vehicle-side of the terminal used in step 10 or step 11.

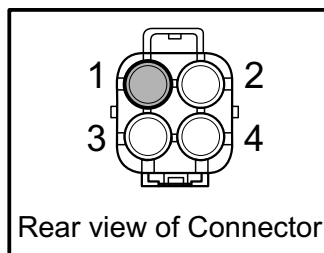

Step 4

- Remove the glovebox (1).

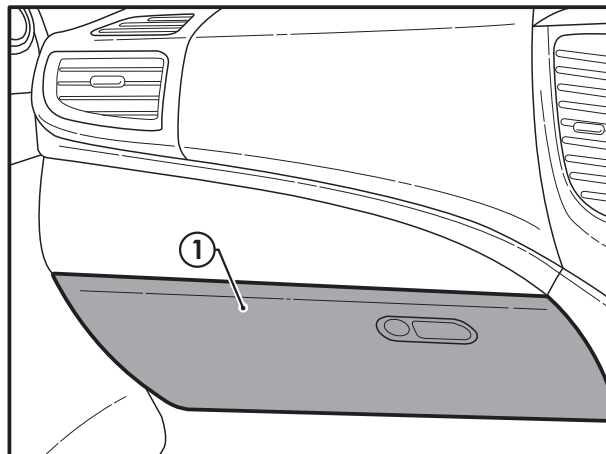

Step 5

- Below the driver side lower dash trim (1), remove the screw (2).
- Dislodge the lower dash trim (1) and remove the vacant switch blank (3).

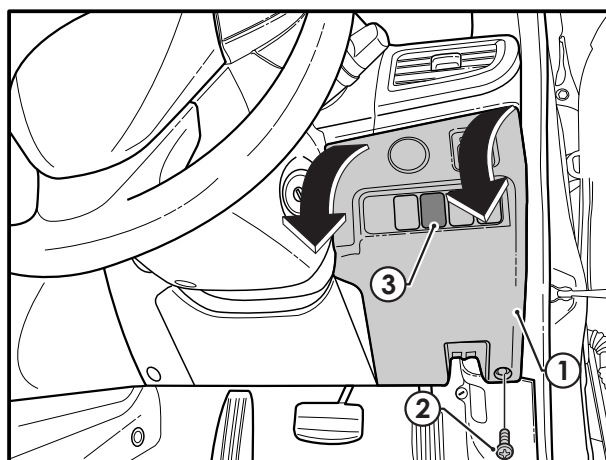

Step 6

- Remove the LHS front scuff plate (1) and dislodge the rubber door seal (2).

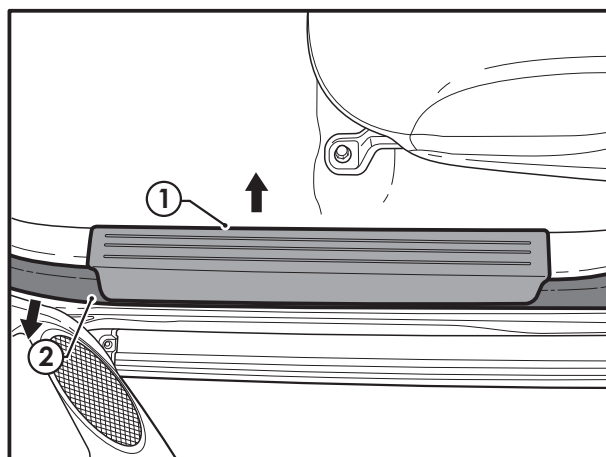

Step 7

- Remove the fastener (1) from the passenger side front kick panel (2).
- Remove the kick panel (2) from the vehicle.

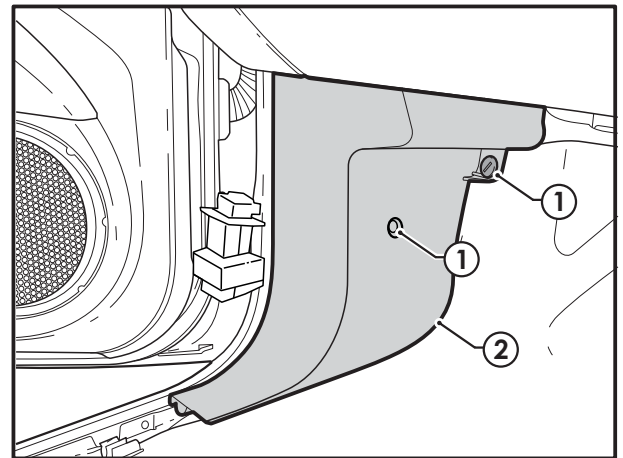

Step 8

- Locate the vehicle 3-way connector (1).

The following step is for vehicles with a 3-way connector already mated and occupied.

- Disconnect the 3-way connectors.
- Remove the foam tape from the 3-way male connector.
- Using a jewellers flat head screw driver, disengage the 3-way connectors secondary lock (4) by releasing the clips (5) on either side and sliding the secondary lock back.
- House the blue wire into the mating connector (2) on the kick panel harness (3) as indicated below.
- Re-engage the 3-way connector secondary lock before joining the connectors back and wrap using the supplied Foam Tape.

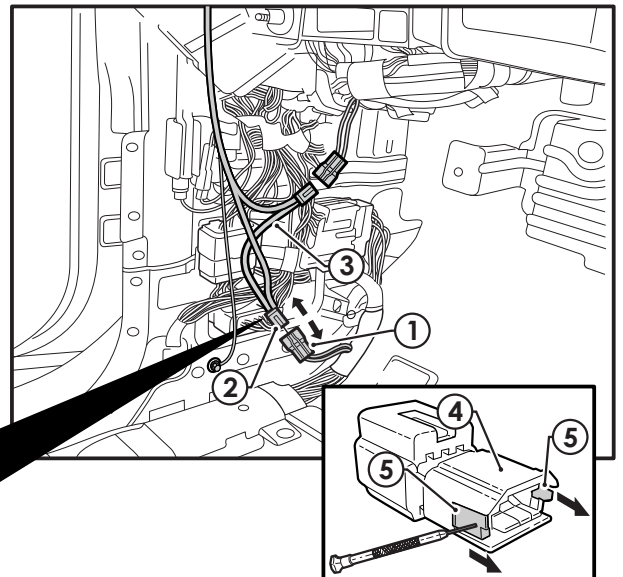

Proceed to Step 10.

Terminal No.	Colour
1	BLUE
2	OCCUPIED
3	OCCUPIED

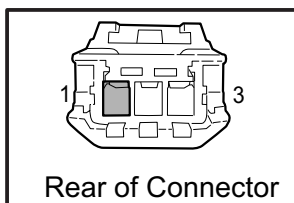

Step 9

The following step is for vehicles without a 3-way connector already mated.

- If a connector is not present, then use the supplied mating 3-Way Male Connector.
- House the blue wire on the kick panel harness (1) in the connector following orientation shown below.
- Engage the 3-Way Male Connector secondary lock (3) by pushing firmly towards the front of the connector.
- Connect the 3-way male connector to the vehicle connector (2) and wrap using the supplied Foam Tape.

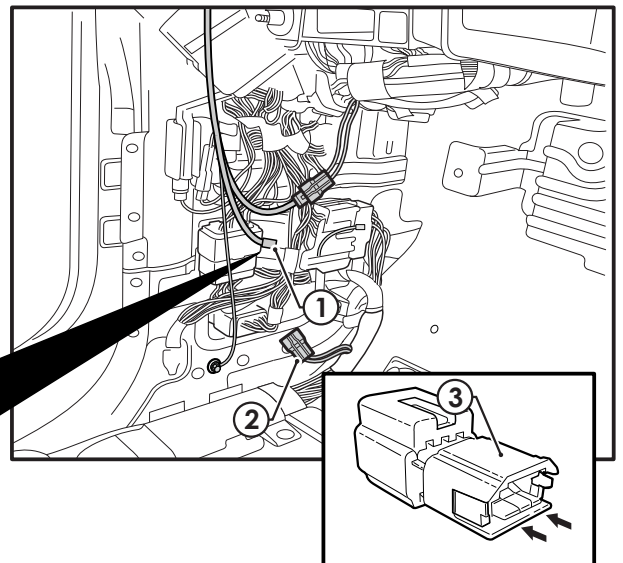

Terminal No.	Colour
1	BLUE
2	-
3	-

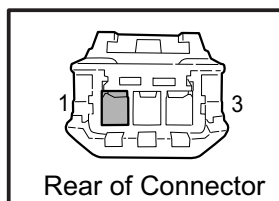

Step 10

The following step is for vehicles with a 4-way connector already mated and occupied.

- Disconnect the 4-way connectors.
- Remove the foam tape from the 4-way male connector (1) and discard.
- Using a jewellers flat head screw driver, disengage the 4-way male connectors secondary lock (4) Ensure the secondary lock is not removed from the connector.
- House the black wire (2) on the kick panel harness (3) into the 4-way male connector (1) as shown below before re-engaging the 4-way male connectors secondary lock.
- Re-join the 4-way connectors and wrap using the supplied Foam Tape.

Note: The colour of the wire on the vehicle side terminal used, must match the wire colour on the vehicle side terminal used in Step 3.

Proceed to Step 12.

Terminal No.	Colour
1	BLACK
2	OCCUPIED
3	-
4	-

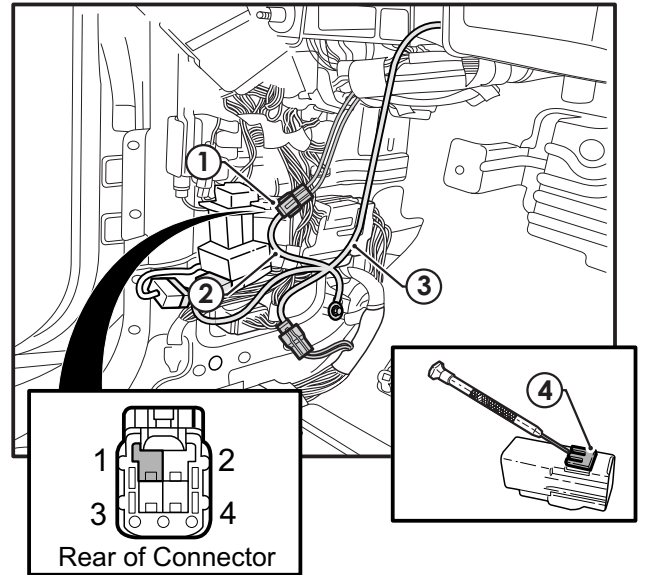

Step 11

The following step is for vehicles WITHOUT a 4-way connector already mated.

- If a 4-way male connector is not present, then use the supplied mating 4-Way Male Connector. Using a jewellers flat head screw driver, disengage the 4-Way Male Connectors secondary lock (4). Ensure the secondary lock is not removed from the connector.
- House the black wire on the kick panel harness (1) in the 4-way Male connector (2) following orientation shown below.
- Re-engage the 4-Way Male Connector secondary lock.
- Connect the 4-way male connector to the vehicle connector (3) and wrap using the supplied Foam Tape.

Note: The colour of the wire on the vehicle side terminal used, must match the wire colour on the vehicle side terminal used in Step 3.

Terminal No.	Colour
1	BLACK
2	-
3	-
4	-

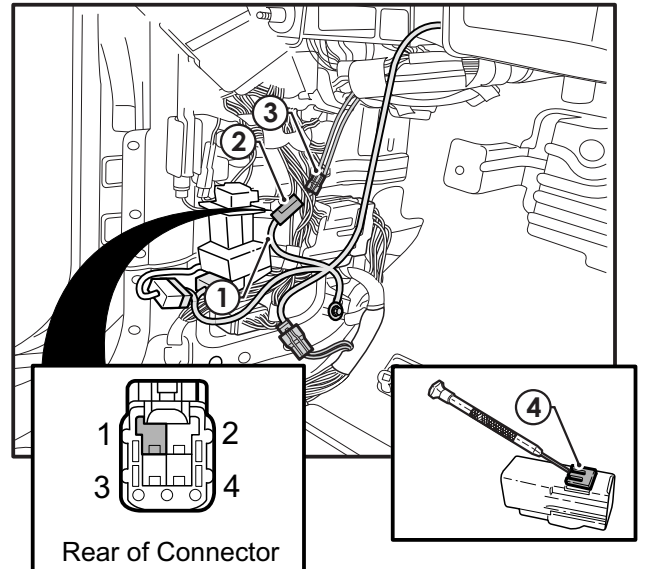

Step 12

- Disconnect the factory vehicle 18-way connector (1).
- Patch in the Kick Panel Harness connectors (2).
- Connect the Kick Panel Harness ground ring terminal (3) to the vehicle ground point.

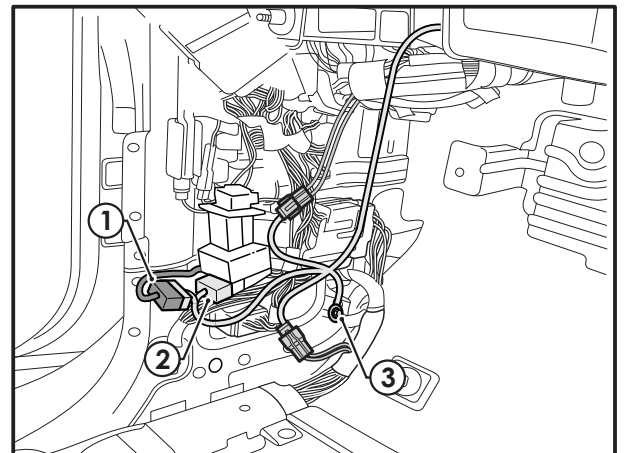

Step 13

- Secure the Brake Controller ECU (1) onto the Brake Controller Bracket (2) using supplied M4 Nyloc Nuts (3) and M4 Flat Washers (4).

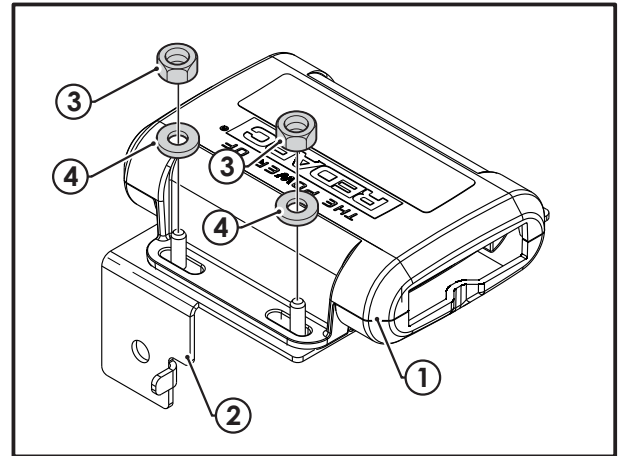

Step 14

- Connect the 4-way connector (1) from the Kick Panel Harness to the Brake Controller ECU (2).
- Connect the Cat 5 Cable (3), supplied in the harness kit, to the Brake Controller ECU (2).

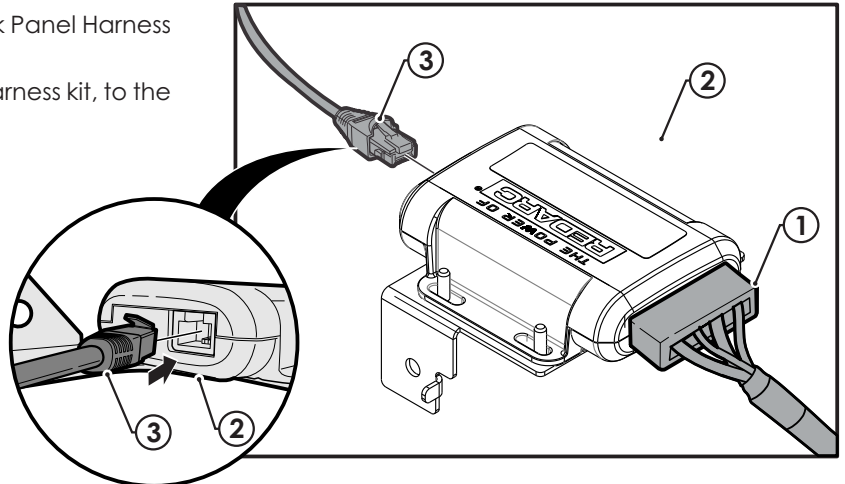

Step 15

- Mount the Brake Controller assembly (1) behind the climate control unit to the existing metal support (2) holes using the supplied M6 Nut and M6 Washer (3).
- Secure the Kick Panel Harness (4) using the supplied Cable Ties.
- Secure the Cat 5 Cable (5) using the supplied Cable Ties.

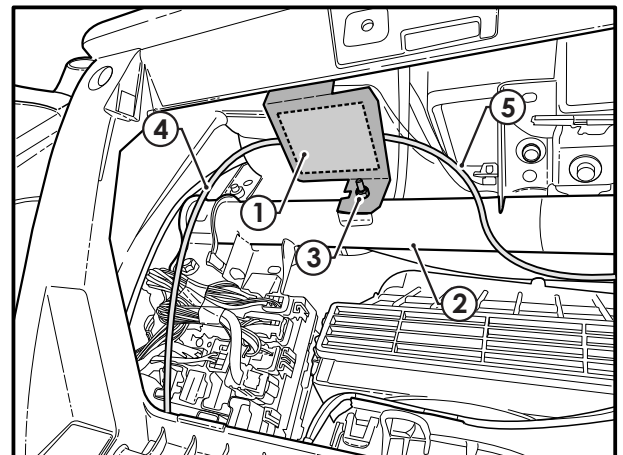

Step 16

- Route the Cat 5 Cable (1) from the Brake Controller ECU to the switch cavity (2).

Important



When routing the Cat 5 Cable (1), ensure it does not interfere with the steering column or the knee airbag in any way.

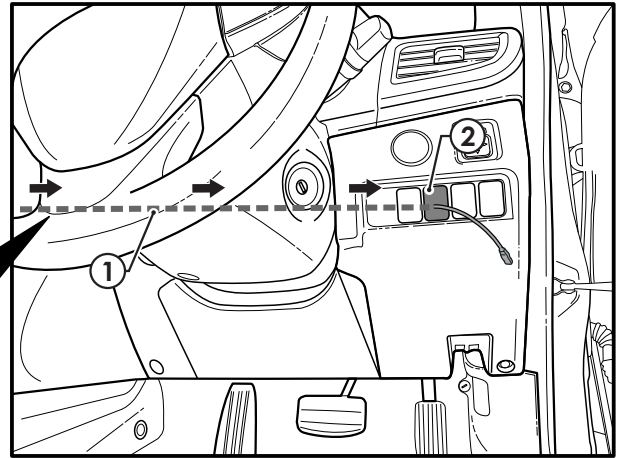
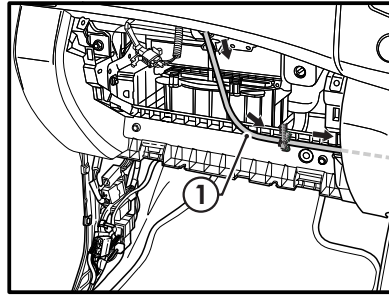

Step 17

- Insert the Switch Insert (1) into the vacant cavity on the switch panel (2).
- Insert the Electric Brake Switch (3) into the Switch Insert (1) from behind.
- Fasten the supplied Nut (4) locking the Electric Brake Switch (3) to the Switch Insert (1). Torque the nut (4) to 0.8Nm.
- Rotate the shaft (5) fully anti-clockwise and fit the knob (6) to the shaft (5) with "0" pointing upwards as shown.
- Route the Cat 5 Cable (7) to the switch panel area (2) and connect to the Electric Brake Switch (3) from behind.
- Secure the Cat 5 Cable (7) using the supplied Cable Ties.

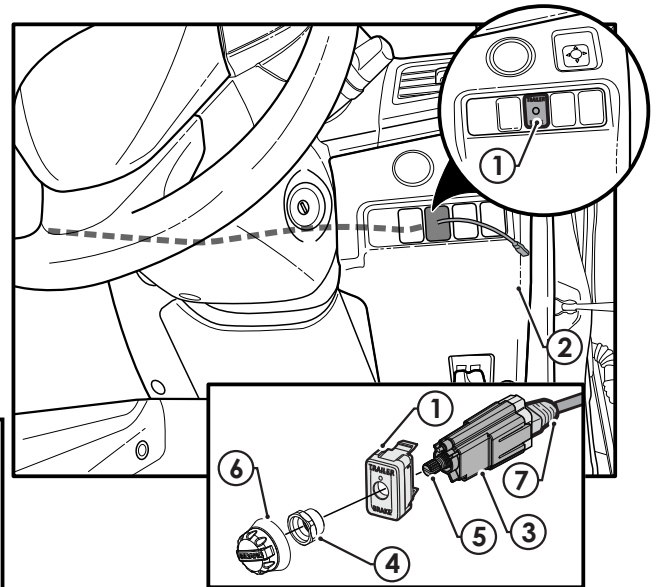
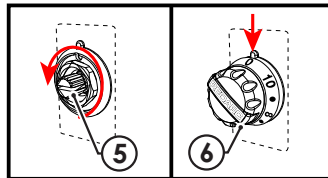

Step 18

Note: The following step are for vehicle's with an unoccupied 3-way connector. For vehicle's that have an occupied 3-way connector, please proceed to Step 20.

- Under the vehicle, locate the 3-way connector (1) at the rear LH chassis rail.
- Disconnect and discard the blanking male 3-way connector (2).
- Fit the Blue Wire (3) from the Brake Signal Harness into the cavity '2' of the supplied mating 3-Way Male Connector (4).
- Insert the supplied Plug Seals into the remaining cavities and fit the supplied Secondary Lock before re-joining the 3-way connectors.
- Route the Brake Signal Harness towards the vehicle trailer wiring harness socket.

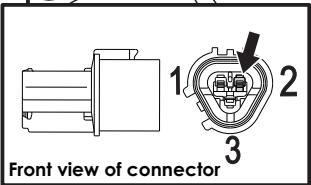
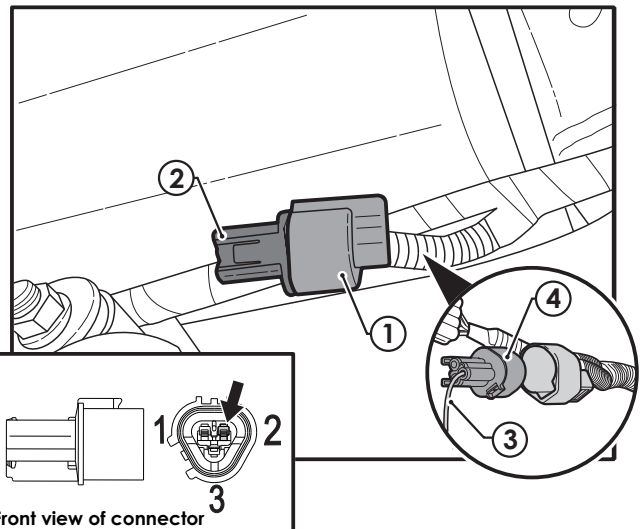

Step 19

- Remove the 'BLUE' wire (1) from the trailer wiring harness socket head (2).
- Tape back and isolate inside the tube.
- Insert new 'BLUE' wire with brass ferrule from the Brake Signal Harness into the same position in the trailer socket.

Pin No.	Function	Cable Colour
1	Left-hand turn signal	Yellow
2	Reversing signal	Black
3	Earth return	White
4	Right-hand signal	Green
5	Service brakes	Blue
6	Stop lamp signal	Red
7	Rear lamps, clearance and side marker lamps	Brown

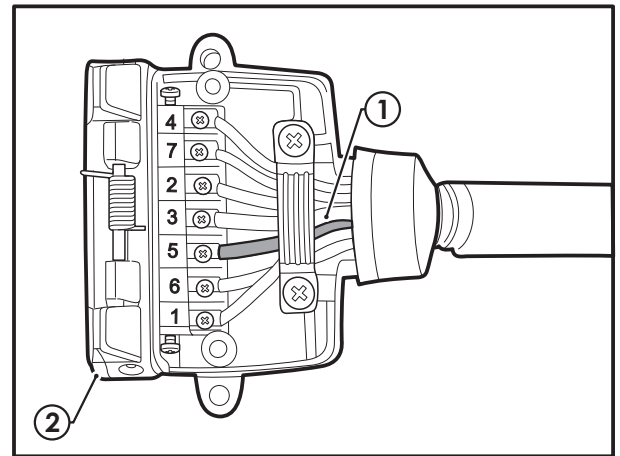

Step 20

- Re-connect the negative battery terminal.
- Test the operation of the Tow-Pro system as per the Tow-Pro user manual.
- Dispose of any parts not used from the fitment.

Important



Secure all harnesses to the vehicle using cable ties. Refit all removed parts and secure all fasteners to the Service Manual torque specifications.

Important



Reprogram all radio stations and clock settings by referring to the vehicle's Owner's Manual.



Please place the Fitting Instructions and Owner's Manual in the glove box after installation is completed.

E. & O.E. This document is copyright and must not be used except as permitted below or under the Copyright Act 1968. You may reproduce and publish this document in whole or in part for your or your organisation's own. Personal or internal compliance, educational or non-commercial purposes. You must not alter or amend this document in any way. You must not reproduce or publish this document for commercial gain without the prior written consent of the copyright owner.

TWO YEAR PRODUCT WARRANTY

Over the last three decades our company has established a reputation as the power conversion specialist.

A 100% Australian-owned company, we have met the needs of customers in transport and other industries through exciting, innovative thinking.

We believe in total customer satisfaction and practice this by offering our customers:

- Technical advice free of jargon and free of charge
- Prompt turnaround of orders throughout Australia and globally
- Friendly, personalised, professional service and product support

In the unlikely event that a technical issue arises with a Redarc product, customers are encouraged to initially contact the Redarc Technical Support Team on (08) 8322 4848 or power@redarc.com.au for prompt and efficient diagnosis and product support.

Our goods come with guarantees that cannot be excluded under the Australian Consumer Law. You are entitled to a replacement or refund for a major failure and compensation for any other reasonably foreseeable loss or damage. You are also entitled to have the goods repaired or replaced if the goods fail to be of acceptable quality and the failure does not amount to a major failure.

The benefits of this Warranty are in addition to other rights and remedies available at law in respect of the Products and shall not derogate from any applicable mandatory statutory provisions or rights under the Australian Consumer Law.

Redarc Electronics Pty Ltd atf the Redarc Trust trading as Redarc Electronics ("Redarc") offers a warranty in respect of its Products where the Products are purchased from an authorised distributor or reseller of Redarc by a person ("Purchaser"), on the terms and conditions, and for the duration, outlined below in this document ("Warranty").

1. In this Warranty, the term **Products** means:
 - 1.1 all products manufactured or supplied by Redarc (excluding its solar products which are covered by Redarc's Solar Product Warranty); and
 - 1.2 any component of or accessory for any product in clause 1.1 manufactured or supplied by Redarc.

Offer and duration of product warranties

2. Redarc warrants that its Products will be free, under normal application, installation, use and service conditions, from defects in materials and workmanship affecting normal use, for **2 years** from the date of purchase (**Warranty Period**).
3. Where a Product malfunctions or becomes inoperative during the Warranty Period, due to a defect in materials or workmanship, as determined by Redarc, then subject to further rights conferred by the Australian Consumer Law on the Purchaser, Redarc will, in exercise of its sole discretion, either:
 - 3.1 repair the defective Product;
 - 3.2 replace the defective Product; or
 - 3.3 provide a refund to the Purchaser for the purchase price paid for the defective Product, without charge to the Purchaser.
4. The warranty given by Redarc in clause 3 covers the reasonable costs of delivery and installation of any repaired or replaced Products or components of Products to the Purchaser's usual residential address notified to Redarc, together with the reasonable costs of removal and return of any Products determined by Redarc to be defective.
5. If the Purchaser incurs expenses of the nature referred to in clause 4 in the context of making a claim pursuant to this Warranty that is accepted by Redarc, the Purchaser will be entitled to claim for reimbursement of those expenses which Redarc determines, in exercise of its sole discretion, to be reasonably incurred, provided that the claim is notified to Redarc in writing at the postal address or email address specified in clause 21 and includes:
 - 5.1 details of the relevant expenses incurred by the Purchaser; and
 - 5.2 proof of the relevant expenses having been incurred by the Purchaser.

Exclusions and limitations

6. This Warranty will not apply to, or include any defect, damage, fault, failure or malfunction of a Product, which Redarc determines, in exercise of its sole discretion, to be due to:
 - 6.1 normal wear and tear or exposure to weather conditions over time;
 - 6.2 accident, misuse, abuse, negligence, vandalism, alteration or modification;
 - 6.3 non-observance of any of the instructions supplied by Redarc, including instructions concerning installation, configuring, connecting, commissioning, use or application of the Product, including without limitation choice of location;
 - 6.4 failure to ensure proper maintenance of the Product strictly in accordance with Redarc's instructions or failure to ensure proper maintenance of any associated equipment or machinery;
 - 6.5 repairs to the Product that are not strictly in accordance with Redarc's instructions;
 - 6.6 installation, repairs or maintenance of the Product by, or under the supervision of, a person who is not a qualified auto electrician or technician, or if non-genuine or non-approved parts have been fitted;
 - 6.7 faulty power supply, power failure, electrical spikes or surges, lightning, flood, storm, hail, extreme heat, fire or other occurrence outside the control of Redarc;
 - 6.8 use other than for any reasonable purpose for which the Product was manufactured;
 - 6.9 any indirect or incidental damage of whatever nature outside the control of Redarc.
7. Warranty claims in respect of a Product must be made in writing to Redarc at the postal address or email address specified in clause 21 within the Warranty Period. Such claims must include the following:
 - 7.1 details of the alleged defect or fault and the circumstances surrounding the defect or fault;
 - 7.2 evidence of the claim, including photographs of the Product (where the subject of the claim is capable of being photographed);
 - 7.3 the serial number of the Product, specified on the label affixed to the Product; and
 - 7.4 proof of purchase documentation for the Product from an authorised distributor or reseller of Redarc, which clearly shows the date and place of purchase.The return of any Products without the prior written instructions of Redarc will not be accepted by Redarc.

8. Without limiting any other clause in this Warranty, Redarc has the right to reject any Warranty claim made by a Purchaser pursuant to this Warranty where:
 - 8.1 the Purchaser does not notify Redarc in writing of a Warranty claim within the Warranty Period;
 - 8.2 the Purchaser does not notify Redarc in writing of a Warranty claim within 1 month of becoming aware of the relevant circumstances giving rise to the claim, so that any further problems with the Product are minimised;
 - 8.3 the serial number of the Product has been altered, removed or made illegible without the written authority of Redarc;
 - 8.4 the Purchaser is unable to provide proof of purchase documentation in accordance with clause 7.4 or evidence that the Product was properly installed and removed (if relevant), and that proper maintenance has been performed on the Product, by, or under the supervision of, a qualified auto electrician or technician, in accordance with the instructions of Redarc.
9. If the Product is found to be working satisfactorily on return to Redarc or upon investigation by Redarc, the Purchaser must pay Redarc's reasonable costs of testing and investigating the Product in addition to shipping and transportation charges. Where Redarc is in possession of the Product, the Product will be returned to the Purchaser on receipt of the amount charged.
10. Any replaced Products or components of Products shall become the property of Redarc.
11. Redarc may, in exercise of its sole discretion, deliver another type of Product or component of a Product (different in size, colour, shape, weight, brand and/or other specifications) in fulfilling its obligations under this Warranty, in the event that Redarc has discontinued manufacturing or supplying the relevant Product or component at the time of the Warranty claim, or where such Product or component is superior to that originally purchased by the Purchaser.

Other conditions of Warranty

12. If the Purchaser acquired a Product for the purpose of resupply, then this Warranty shall not apply to that Product.
13. In particular, the sale of a Product via an online auction, online store or other internet website by a party that is not an authorised distributor or reseller of the Product will be deemed to be a resupply within the meaning of the Australian Consumer Law and will render this Warranty void, as Redarc has no control over the storage, handling, quality or safety of Products sold by such persons.
14. A Purchaser shall only be entitled to the benefit of this Warranty after all amounts owing in respect of the Product have been paid.
15. While Redarc warrants that the Products will be free from defects in materials and workmanship in the circumstances set out in this Warranty, to the maximum extent permitted by law Redarc does not warrant that the operation of the Products will be uninterrupted or error-free.
16. To the maximum extent permitted by law, Redarc's determination of the existence of any defect and the cause of any defect will be conclusive.
17. Spare parts or materials for the Products are guaranteed to be available for a period of at least 2 years after purchase of the Products.
18. The agents, officers and employees of any distributor or reseller of the Products and of Redarc are not authorised to vary or extend the terms of this Warranty.
19. Redarc shall not be responsible or liable to the Customer or any third party in connection with any non-performance or delay in performance of any terms and conditions of this Warranty, due to acts of God, war, riots, strikes, warlike conditions, plague or other epidemic, fire, flood, blizzard, hurricane, changes of public policies, terrorism and other events which are beyond the control of Redarc. In such circumstances, Redarc may suspend performance of this Warranty without liability for the period of the delay reasonably attributable to such causes.
20. If a clause or part of a clause in this Warranty can be read in a way that makes it illegal, unenforceable or invalid, but can also be read in a way that makes it legal, enforceable and valid, it must be read in the latter way. If any clause or part of a clause in this Warranty is illegal, unenforceable or invalid, that clause or part is to be treated as removed from this Warranty, but the rest of this Warranty is not affected.

Redarc's contact details

21. Redarc's contact details for the sending of Warranty claims under this Warranty are:
Redarc Electronics Pty Ltd
23 Brodie Road (North), Lonsdale SA 5160
Email: power@redarc.com.au
Telephone: +61 8 8322 4848