

MISSION-CRITICAL
INTERCONNECT
SOLUTIONS



Glennair
SIGNATURE SERIES



Fiber Optics and Photonics for Aerospace Applications

Harsh-Environment Fiber Optic Connectors and Cable
Assemblies *Plus* Ruggedized Aerospace-Grade Photonics



Fiber Optics and Photonics for Aerospace Applications

Harsh-Environment Fiber Optic Connectors and Cable Assemblies *Plus* Ruggedized Aerospace-Grade Photonics

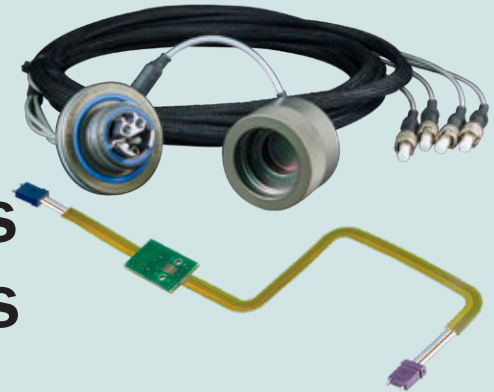

Turnkey fiber optic and Ruggedized PhotonicFlex assemblies

MT FERRULE: RUGGEDIZED, HIGH-DENSITY

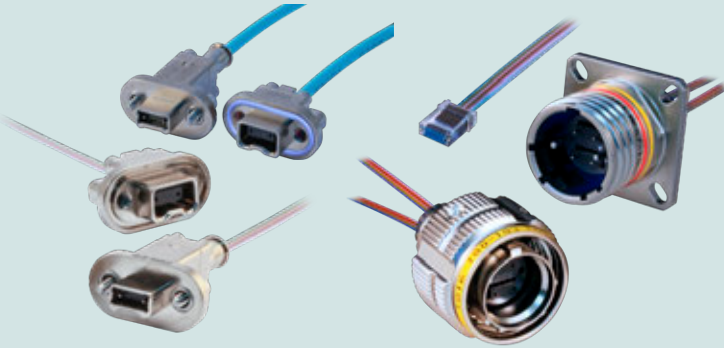

Rugged MT and expanded-beam MT for SuperNine® D38999 and Series 79 connectors—our highest-density solution

GLENAIR FRONT RELEASE (GFR): THE FAST ROAD TO FIBER OPTIC INTEGRATION

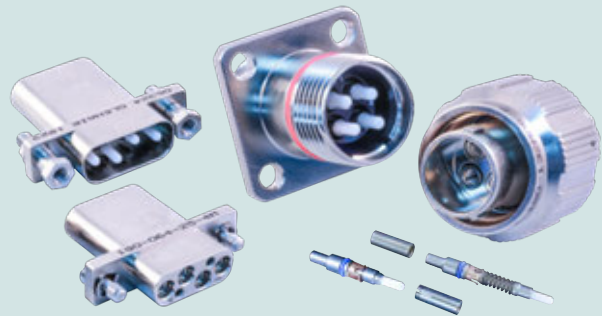

Glenair Front Release (GFR) fiber optic connection system termini directly incorporate retention clip and sealing

SERIES 806 MIL-AERO: MIL-DTL-38999 PERFORMANCE IN A MICRO MINIATURE PACKAGE

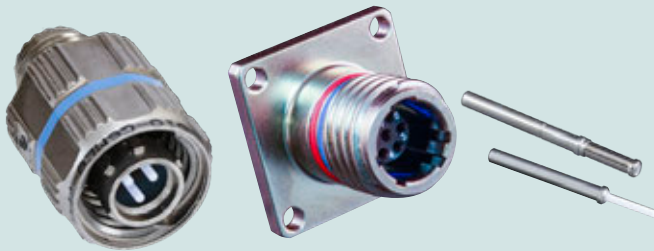

Series 806 Mil-Aero micro miniature fiber optics: advanced performance, reduced size and weight

GLENAIR HIGH DENSITY (GHD): THE SIZE #18 TERMINI HIGH-DENSITY SOLUTION

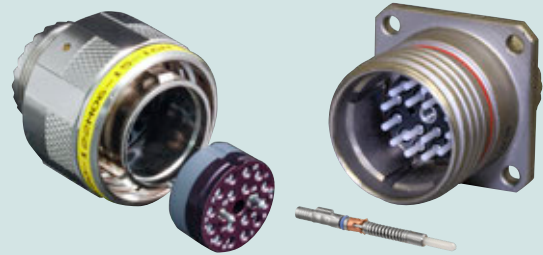

Glenair High Density (GHD) rugged fiber optics: nearly double the density of standard butt-joint solutions

MIL-DTL-38999 SERIES III TYPE: THE AEROSPACE STANDARD FOR FIBER OPTICS



The Joint Strike Fighter solution: tight-tolerance MIL-DTL-38999 type fiber optic connectors with QPL termini

ARINC 801: STANDARD DENSITY HERMAPHRODITIC CONTACT SOLUTION



ARINC 801 ultra-low dB loss fiber optic insert in a standard MIL-DTL-38999 connector package

RUGGED PCB-MOUNT TRANSCEIVERS FOR ETHERNET, HIGH-SPEED VIDEO, AND STORAGE

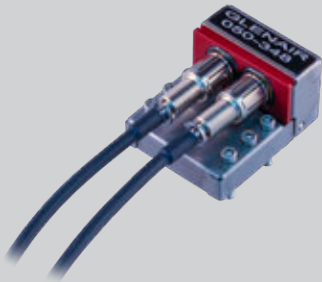

EMI shielded and radiation-tolerant transceivers

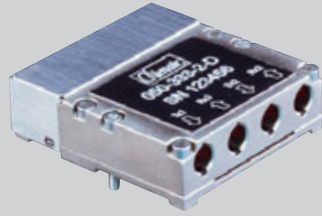

Dual transceivers, quad transmitters, quad receivers

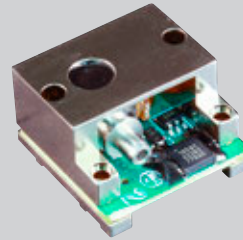

Bi-directional transceivers

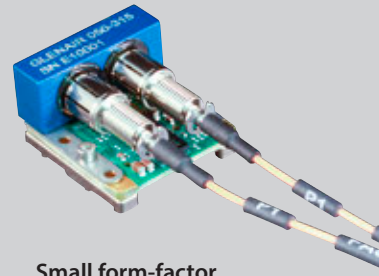

Small form-factor, high-vibration high-temperature tolerant

RF-OVER-FIBER AND HIGH-DATARATE PARALLEL OPTICAL TRANSCEIVERS

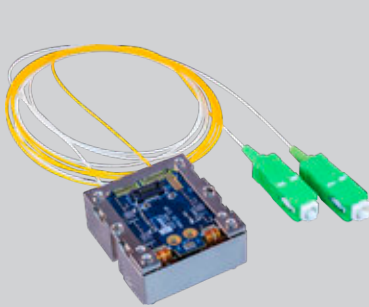

RF-over-fiber low-noise PCB-mount transceiver



Parallel optical 40 Gb/s PCB-mount transceivers

PHOTONIC CONTACTS AND CONNECTORS FOR BOX I/O FIBER-TO-COPPER MEDIA CONVERSION

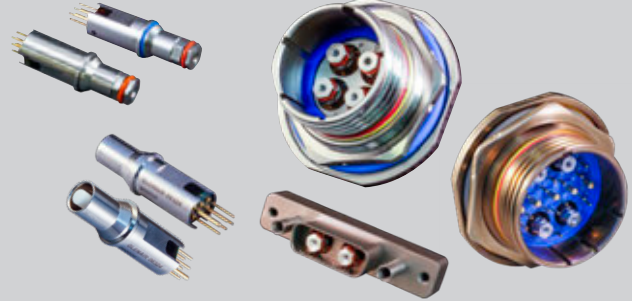

Opto-electronic receptacle connectors populated with Size #8 Photonic transmitter and receiver contacts

RUGGED ELECTRICAL-OPTICAL MEDIA CONVERTERS



Copper-to-fiber media converters for video applications

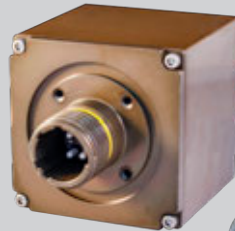

Copper-to-fiber media converters for Ethernet applications



ETHERNET SWITCHES / AGGREGATORS



Rugged aggregated signal and Ethernet switch technologies

COMPLEMENTARY HIGH-SPEED HYBRID AND ELECTRICAL INTERCONNECT SOLUTIONS

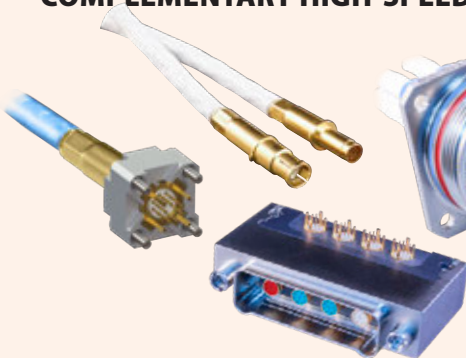

El Ochito® high-speed octaxial contacts with Series 806 Mil-Aero micro miniature circular and Series 792 rectangular packaging



High-Speed Micro-D high-density SWaP solution

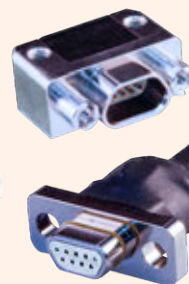

Hybrid optical / electrical interconnect solutions

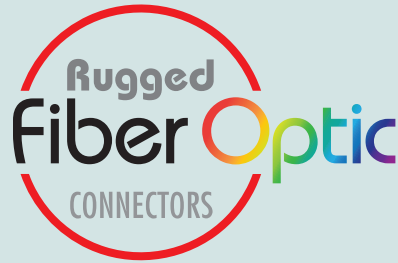

Fiber Optic Cables and Harnesses: turnkey environmental and inside-the-box assemblies

Glenair manufactures every popular mission-critical fiber optic interconnect system including MIL-DTL-38999 type, MIL-DTL-64266 NGCON, MIL-PRF-28876, ARINC 801, and more. Our fiber optic cable assembly team can integrate these ruggedized, military grade fiber optic technologies into turnkey cable and harness assemblies—terminated, tested, and ready for immediate use. Examples shown below range from inside-the-box pigtail assemblies to harsh environmental aerospace cables, junction boxes, and hybrid optical / electrical solutions.



Hybrid environmental overmolded fiber optic / electrical cable assembly, MIL-DTL-38999 type with 29504/4 and /5 QPL termini

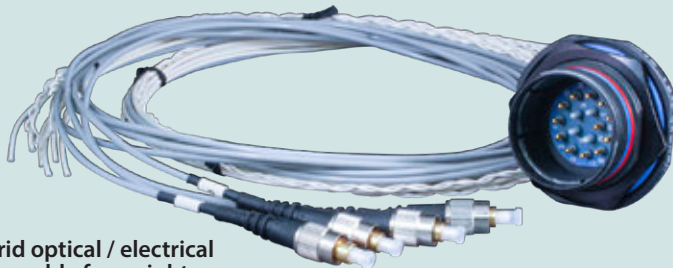

Hybrid optical / electrical assembly for weight reduction in a high-speed datalink application

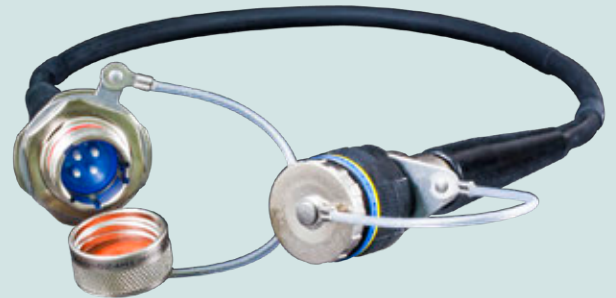

Harsh environment overmolded MIL-DTL-38999 Series III type composite



High-density Next-Generation (NGCON) fiber optic harness assembly



Cable reels and field-deployment technologies for both Glenair GFOCA and Eye-Beam® GMA fiber optic systems



Specialized MT ribbon fiber low-profile molded breakout capabilities



GFOCA I/O-to-board assembly with overbraiding for mechanical protection

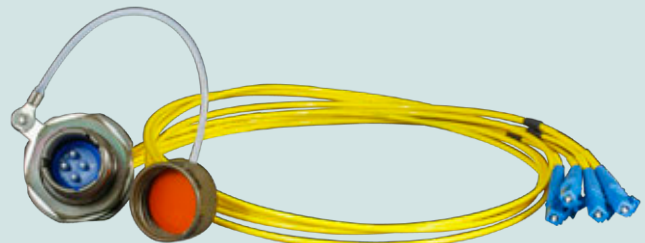

Inside-the-box MIL-DTL-38999 type I/O connector to board cable harness

TURNKEY
Fiber Optic Cables and Harnesses
 for rugged mission-critical applications



Hybrid MIL-DTL-38999 series III type fiber optic / electrical cable junction box



Harsh environment repairable MIL-DTL-38999 Series III type with FiberCon backshell to prevent fiber media damage



Field-deployable hermaphroditic GFOCA fiber optic cable assembly

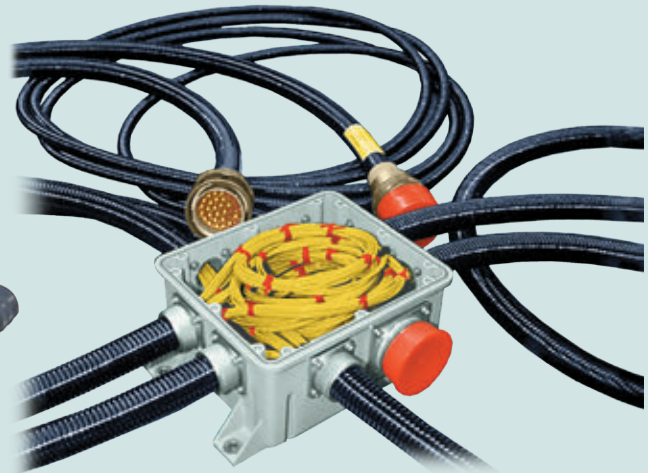

Fiber optic multibranch assembly with flexible conduit wire protection and integrated cable storage bay



Point-to-point fiber optic cable with integrated strain relief



High-speed video fiber optic switch and cable junction box assembly

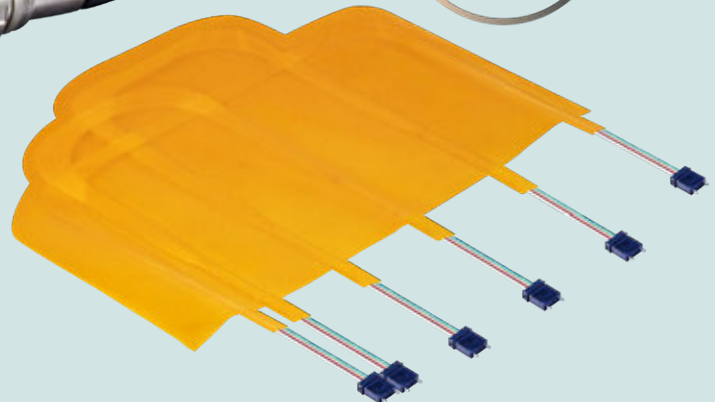

Turnkey PhotonicFlex (optical flex circuit assembly) with rugged MT ferrule terminations

GLENAIR
SIGNATURE
FIBER OPTIC
CONNECTION
SYSTEMS

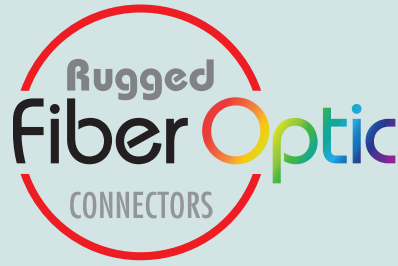

Rugged High-Density
MT Ferrule Fiber Optic
Connection System—with
Mil-Grade SuperNine[®]
Packaging



Ruggedized, high-density MT ferrule
fiber optics in Glenair Signature
SuperNine[®] aerospace-grade
MIL-DTL-38999 connectors

- Singlemode and multimode fiber
- Low insertion loss
- Environmental sealing: IP67 mated, IP68 available at interface
- Physical contact and expanded beam
- Available in composite

ALSO AVAILABLE: EXPANDED-BEAM MT SOLUTIONS

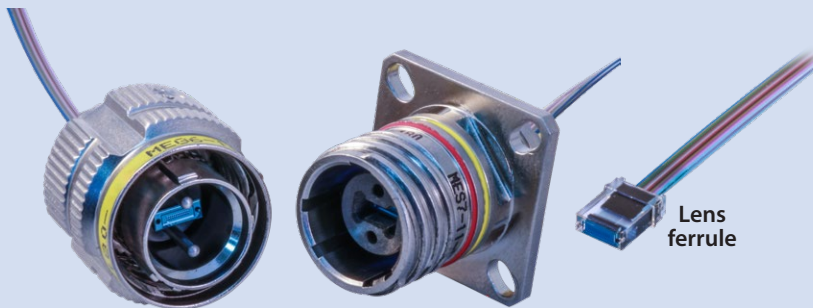

RUGGED, HIGH-DENSITY

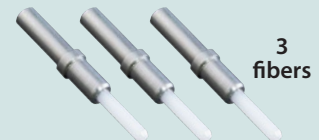

Up to 24 fibers in a single compact,
lightweight ferrule (7mm x 3mm)

ULTRA HIGH-DENSITY MT Ferrule



Signature fiber optic connection system: SuperNine D38999

SuperNine® connectors with plug-and-play MT ferrule accommodation - Shell Size / Insert Arrangements			
Shell Size-Insert Arrangement 11-1 Up to 24 fibers (1 MT ferrule)	Shell Size-Insert Arrangement 13-2 Up to 48 fibers (2 MT ferrules)	Shell Size-Insert Arrangement 15-3 Up to 72 fibers (3 MT ferrules)	Shell Size-Insert Arrangement 17-4 Up to 96 fibers (4 MT ferrules)

SuperNine® MT Performance Specifications	
Test Description	Performance Requirements/Specifications
Optical Insertion Loss, Multimode Expanded Beam	-0.5 dB Typical (50/125)
Optical Insertion Loss, Multimode PC	-0.3 dB Typical (50/125)
Optical Insertion Loss, Singlemode PC	-0.3 dB Typical (9/125)
Optical Insertion Loss, Singlemode APC	-0.3 dB Typical (9/125)
Optical Back Reflection, Multimode Expanded Beam	Better than -28 dB
Optical Back Reflection, Singlemode PC	Better than -30 dB
Optical Back Reflection, Singlemode APC	Better than -60 dB
Mechanical Shock	300 G Half-sine Pulse, 3 ms Duration, 3 Times Both Direction Each Axis per TIA-455-14A
Vibration, Random	49.5 Grms at Ambient Temperature per MIL-STD-1678-3, Measurement 3201, Test Condition C, 5.3c, 8 hours exposure each axis
Mating Durability	500 Mating Cycles per TIA-455-21A
Humidity *	90%-95% RH, 96 hour Exposure per TIA-455-5C, Method A, Test Condition A
Thermal Cycle *	5 Cycles, -40°C to 85°C with 1 hour Exposure per EIA-364-32F, Condition VIII, Method A
Temperature Life *	85°C for 336 hours per TIA-455-4C

*cable and epoxy dependent

TURNKEY SUPERNINE® MT FIBER OPTIC CABLE SETS

Glenair can design, terminate, and test complex multibranch and point-to-point assemblies incorporating SuperNine® MT connectors Panel mount MT receptacles may be terminated to standard commercial fiber optic interconnects for termination to board-level transceivers. MT plug assemblies are available with ruggedized backshells or environmental overmolding. Low-profile cable overmolds provide fiber media organization and ribbon-to-wire strain relief.



PARALLEL OPTICAL TRANSCEIVERS



The ideal solution for board-level optical-to-electrical conversion utilizing MT fiber optic ferrules.

HOW-TO-ORDER MT FERRULE KITS

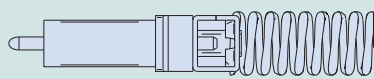
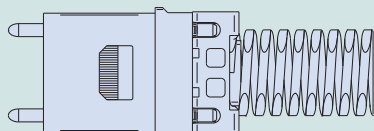

Sample Part Number	181-139	-1253	-12	M
Basic Part Number	MT Ferrule kit			
Fiber type	-126, -1253, -1253A (See Table I)			
Number of Fibers	-12, -24 (See Table I)			
Ferrule Style	M = Male (use with Plug) F = Female (use with Receptacle)			

Table I					
Dash No.	Fiber Type	End Face	Fiber Size Core/Cladding	No. of Fibers	Ferrule Identification
-126	MM	PC	50/125 62.5/125	12 24	E-ME12 E-ME24
-1253	SM	PC	9/125	12	E-E12
-1253A	SM	APC	9/125	24	E-E24

MATERIAL/FINISH

- Ferrule: Polyphenylene Sulfide Resin
- Pin Clamp, Spring: Stainless Steel
- Boot: TPE

SERIES 183-002 SuperNine MT Fiber Optic Connectors

How to order connectors

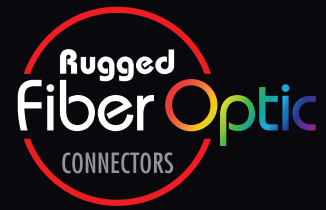

SuperNine MT Cable Plug						
Sample Part Number	183-002	ME	G6	-17-4	N	1
Basic Part Number	MT Ferrule Fiber Optic Connector					
Material/Finish Code	See Table I					
Connector Style	G6 = Plug with EMI/RFI ground spring					
Shell Size / Insert Arrangement	11-1, 13-2, 15-3, 17-4 Order MT ferrule kit P/N 181-139					
Alternate Key Position	A, B, C, D, E, N = Normal U = Universal (per MIL-DTL-38999)					
Insert Cavity Clocking Orientation (see Table II)	1 = Standard position 2 = Cavity position rotated 45° to master key/keyway 3 = Cavity position rotated 90° to master key/keyway					

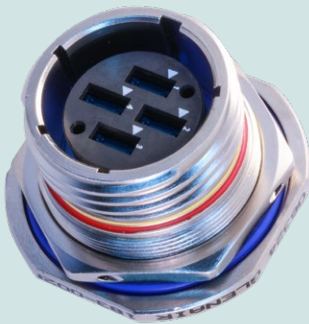

SuperNine MT Jam Nut Mount Receptacle						
Sample Part Number	183-002	ME	08	-17-4	N	1
Basic Part Number	MT Ferrule Fiber Optic Connector					
Material/Finish Code	See Table I					
Connector Style	08 = Jam nut receptacle					
Shell Size / Insert Arrangement	11-1, 13-2, 15-3, 17-4 Order MT ferrule kit P/N 181-139					
Alternate Key Position	A, B, C, D, E, N = Normal U = Universal (per MIL-DTL-38999)					
Insert Cavity Clocking Orientation (see Table II)	1 = Standard position 2 = Cavity position rotated 45° to master key/keyway 3 = Cavity position rotated 90° to master key/keyway					



SuperNine MT In-Line Receptacle						
Sample Part Number	183-002	ME	05	-17-4	N	1
Basic Part Number	MT Ferrule Fiber Optic Connector					
Material/Finish Code	See Table I					
Connector Style	05 = In-line receptacle					
Shell Size / Insert Arrangement	11-1, 13-2, 15-3, 17-4 Order MT ferrule kit P/N 181-139					
Alternate Key Position	A, B, C, D, E, N = Normal U = Universal (per MIL-DTL-38999)					
Insert Cavity Clocking Orientation (see Table II)	1 = Standard position 2 = Cavity position rotated 45° to master key/keyway 3 = Cavity position rotated 90° to master key/keyway					

How to order connectors

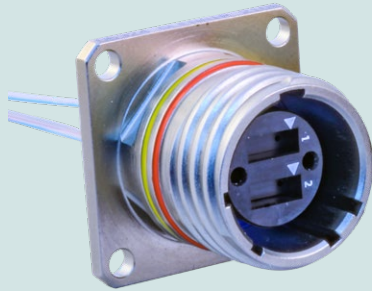

SuperNine MT Wall-Mount Receptacle, Standard Holes				
Sample Part Number	183-002	ME	H7	-17-4 N 1
Basic Part Number	MT Ferrule Fiber Optic Connector			
Material/Finish Code	See Table I			
Connector Style	H7 = Wall-mount receptacle with round holes			
Shell Size / Insert Arrangement	11-1, 13-2, 15-3, 17-4 Order MT ferrule kit P/N 181-139			
Alternate Key Position	A, B, C, D, E, N = Normal U = Universal (per MIL-DTL-38999)			
Insert Cavity	1 = Standard position			
Clocking Orientation (see Table II)	2 = Cavity position rotated 45° to master key/keyway 3 = Cavity position rotated 90° to master key/keyway			

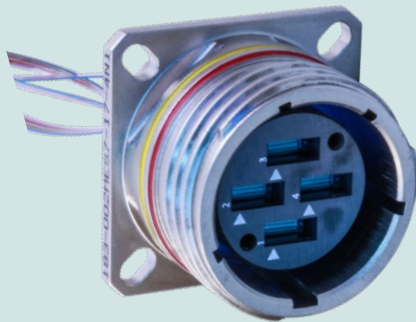

SuperNine MT Wall-Mount Receptacle, Slotted Holes, Clinch Nuts, Helicoils				
Sample Part Number	183-002	ME	S7	-17-4 N 1
Basic Part Number	MT Ferrule Fiber Optic Connector			
Material/Finish Code	See Table I			
Connector Style	S7 = Wall-mount receptacle with slotted holes CM = Wall-mount receptacle with metric clinch nuts CS = Wall-mount receptacle with standard clinch nuts HM = Wall-mount receptacle with metric helicoils HS = Wall-mount receptacle with standard helicoils			
Shell Size / Insert Arrangement	11-1, 13-2, 15-3, 17-4 Order MT ferrule kit P/N 181-139			
Alternate Key Position	A, B, C, D, E, N = Normal U = Universal (per MIL-DTL-38999)			
Insert Cavity	1 = Standard position			
Clocking Orientation (see Table II)	2 = Cavity position rotated 45° to master key/keyway 3 = Cavity position rotated 90° to master key/keyway			

Code	Material	Finish Description
ME	Aluminum Alloy	Electroless Nickel
MT		Nickel-PTFE, Grey
NF		Cadmium, Olive Drab
ZR		Zinc-Nickel, Black
TZ		Tin-Zinc, Green/Gold
XM	Composite	Electroless Nickel
XW		Cadmium, Olive Drab
Z1	Stainless Steel	Passivate
ZL		Electro-Deposited Nickel

Code	Shell Size-Arrangement 11-1	Shell Size-Arrangement 13-2	Shell Size-Arrangement 15-3	Shell Size-Arrangement 17-4
1				
2				
3				

NOTES

- Pin (male) and socket (female) ferrule kits can be used in either plug or receptacle connectors. Preferred configuration is female ferrule in receptacle connector

GLENAIR
SIGNATURE
FIBER OPTIC
CONNECTION
SYSTEMS

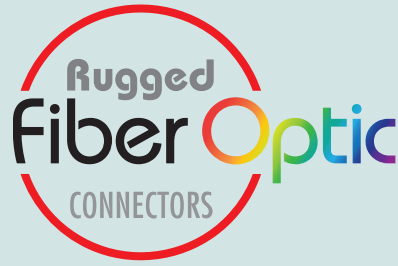

Rugged High-Density
MT Ferrule Fiber Optic
Connection System—
With Mil-Grade Miniature
Series 79 Packaging



Single-ferrule high-density
MT datalinks in Glenair
Signature Series
79 rectangular
packaging
optimize SWaP in
mission-critical
mil-aero
applications



Connector series supports
both ribbon and round
cable, as well as standard
and expanded-beam
MT ferrules

- Small form-factor, high-density fiber optic solution for rugged mil-aero applications
- Temperature tolerance from -40°C to +85°C
- Optimized for use with parallel optical transceivers in ribbon or round cable applications
- Designed for optimal low insertion loss performance in high vibration and shock environments

ULTRA HIGH-DENSITY Rugged MT Fiber Optic Connectors



Signature fiber optic connection system: miniature Series 79 packaging

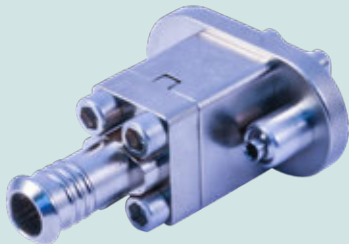

-06 plug, with retaining plate for EMI shield termination and strain relief of ribbon or round fiber cable



-S7 receptacle with standard retaining plate



-S7 receptacle with conductive EMI gasket

ABOUT SERIES 79 MT FIBER OPTIC CONNECTORS

Designed in accordance with rugged mil-aero industry specifications, the Glenair Series 79 MT fiber optic connector is the world's smallest ruggedized MT connector solution. High-density MT ferrules are packaged in precision-machined rectangular aluminum shells with electroless nickel finish, or passivated stainless steel shells for higher temperature applications. Receptacles may be equipped with optional EMI gaskets, and mate bottom-to-bottom with plug assemblies for robust resistance to vibration and shock. Designed for harsh-environment, inside-the-box use in parallel optics, fiber optic backplanes, missile systems, spacecraft and satellites, heads-up displays, and other ribbonized or flex-circuit fiber optic datalinks, the Series 79 MT delivers superior low insertion-loss performance (up to 500 mating cycles). Connectors are supplied in single (consult factory for dual and quad) MT configurations with banding platform or ultra low-profile retaining plate options.

The MT Ferrule High-Density Advantage

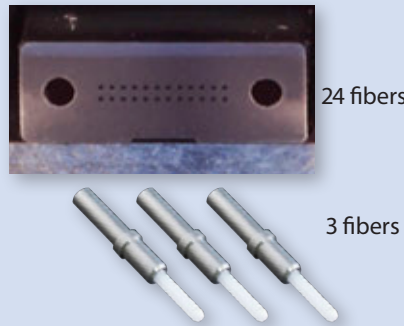

Up to 24 fibers in a single compact, lightweight ferrule (7mm x 3mm / .276" x .118")—same real estate as three size #16 termini side by side

PARALLEL OPTICAL TRANSCEIVERS



Glenair's rugged, small form-factor parallel optical transceivers are the ideal solution for board-level optical-to-electrical conversion utilizing MT fiber optic ferrules.

Series 79 MT Ferrule Fiber Optic Connector Performance Specifications per QTP-773 and Test Report GT-19-111

Test Description	Test Results
Optical Insertion Loss, multimode (consult factory for singlemode)	50/125 μ m fiber @ 850 nm: \leq 0.15 dB average; 0.31 dB typical 50/125 μ m fiber @ 1300 nm: \leq 0.21 dB average; 0.38 dB typical
Temperature Cycling: per TIA/EIA-455-3, Test Condition C-2	- 40°C to +85°C, 5 Cycles, 56 hours Max. CIT = .25 dB; Max. IL post-test = .30 dB
Mating Durability	First 100 cycles with CIT measured every 10 cycles Max. CIT = 0.12 dB; Max. IL post-test = 0.20 dB
Mating Durability, Extended	From 101st cycle to 500th cycle with CIT measured every 25 cycles Max. CIT = 0.21 dB; Max. IL post-test = 0.30 dB
Physical Shock 1: 50g Peak, 11 ms duration, per TIA/EIA-455-14, Test Condition E	Max. CIT = 0.14 dB; Max. IL post-test = 0.42 dB; discontinuity \leq 0.5 dB @ <1 us.
Physical Shock 2: 160g Peak, 4 ms duration, per MIL-STD-202, Method 213	Max. CIT = 0.04 dB; Max. IL post-test = 0.40 dB; discontinuity \leq 0.5 dB @ <1 us.
Additional Physical Shock: 300g Peak, 0.5 ms duration, per MIL-STD-833E, Method 2002.4 (30 shocks total)	Max. CIT = .15 dB; Max. IL post-test = 0.20 dB; discontinuity \leq 0.5 dB @ <1 us.
Vibration 1: 5-15 Hz, .12" double amplitude, 2 hours/axis (6 hours total) per MIL-STD-202, test condition 201, Sinusoidal	Max. CIT = 0.06 dB; Max. IL post-test = 0.37 dB
Vibration 2 : 20g Peak, 10-2,000 Hz, 4 hours/axis (12 hours total) per TIA-455-11, Test Condition IV, Sinusoidal	Max. CIT = 0.08 dB; Max. IL post-test = 0.43 dB
Weight	Plug with Ferrule kit 5.5 grams · Receptacle with Ferrule kit 7.5 grams

SERIES 79 MINIATURE MT Fiber Optic Connectors

183-003 Standard Series 79 MT How To Order



How To Order	
Sample Part Number	183-003 ME -06 -L -1 A -APC
Basic Number	Series 79 Single MT Fiber Optic Connector
Material / Finish	ME = Al Alloy / Electroless Nickel MT = Al Alloy / Nickel PTFE ZR = Al Alloy / Zinc Nickel, Black NF = Al Alloy / Cadmium, O.D. Z1 = Stainless Steel / Passivate
Connector Type	-06 = Plug (used with male MT ferrule) -07 = Receptacle (used with female MT ferrule) -S7 = Receptacle with EMI gasket (used with female MT ferrule)
Mounting Hardware	Hardware for PLUGS Rear Panel Mount Jackposts for RECEPTACLES: -L = Hex Head Jackscrew, non-removable -X = for .031" panel thickness -K = Slotted Head Jackscrew, non-removable -W = for .047" panel thickness -B = Thru-Hole -V = for .062" panel thickness -T = for .094" panel thickness -R = for .080" panel thickness
Retaining Plate / Banding Platform	-1 = 12 or 24 channel without banding platform -2 = 12 or 24 channel with banding platform for EMI shield termination and strain relief N = No Retaining Plate (For use with standalone retaining plate) See Dwg. 189-168 for various retaining plate designs See Dwg. 189-177 for retaining plate used with Prizm-MT on Jacketed Cable
Polarization Key Position	A or B position for Plug; A, B, or U position for Receptacle Omit for no Polarization Key. See Table.
APC / Flat MT option	-APC = for use with angled MT Ferrule (MT/APC) Omit = for use with flat MT ferrule (MT/PC) including Prizm-MT

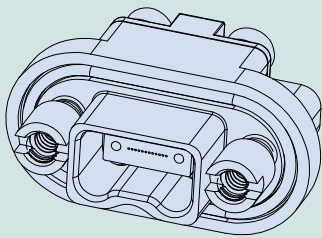

Receptacle with female MT ferrule, available with or without EMI gasket

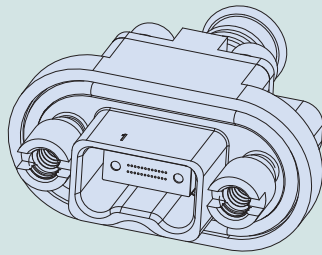

Receptacle with female MT ferrule, retaining plate, and banding platform

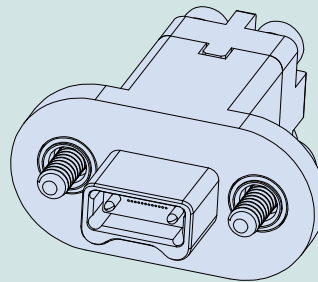

Plug with male MT ferrule and retaining plate

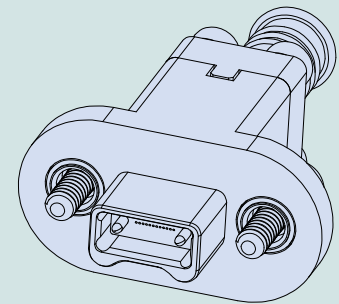

Plug with male MT ferrule with retaining plate and banding platform

MATERIAL/FINISH/NOTES

Mounting hardware: stainless steel / passivated

EMI gasket (optional): conductive silicone

Additional materials, finishes, connector configurations (dual and quad layouts), and hardware options are available, consult factory

SERIES 79 MINIATURE MT Fiber Optic Connectors



183-003 Standard Series 79 MT Connector styles and dimensions

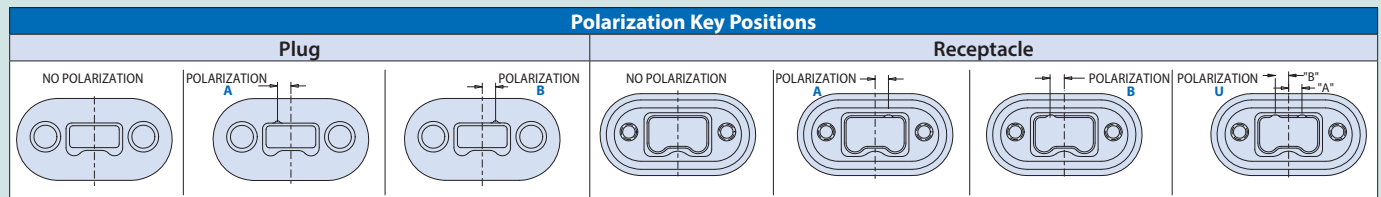
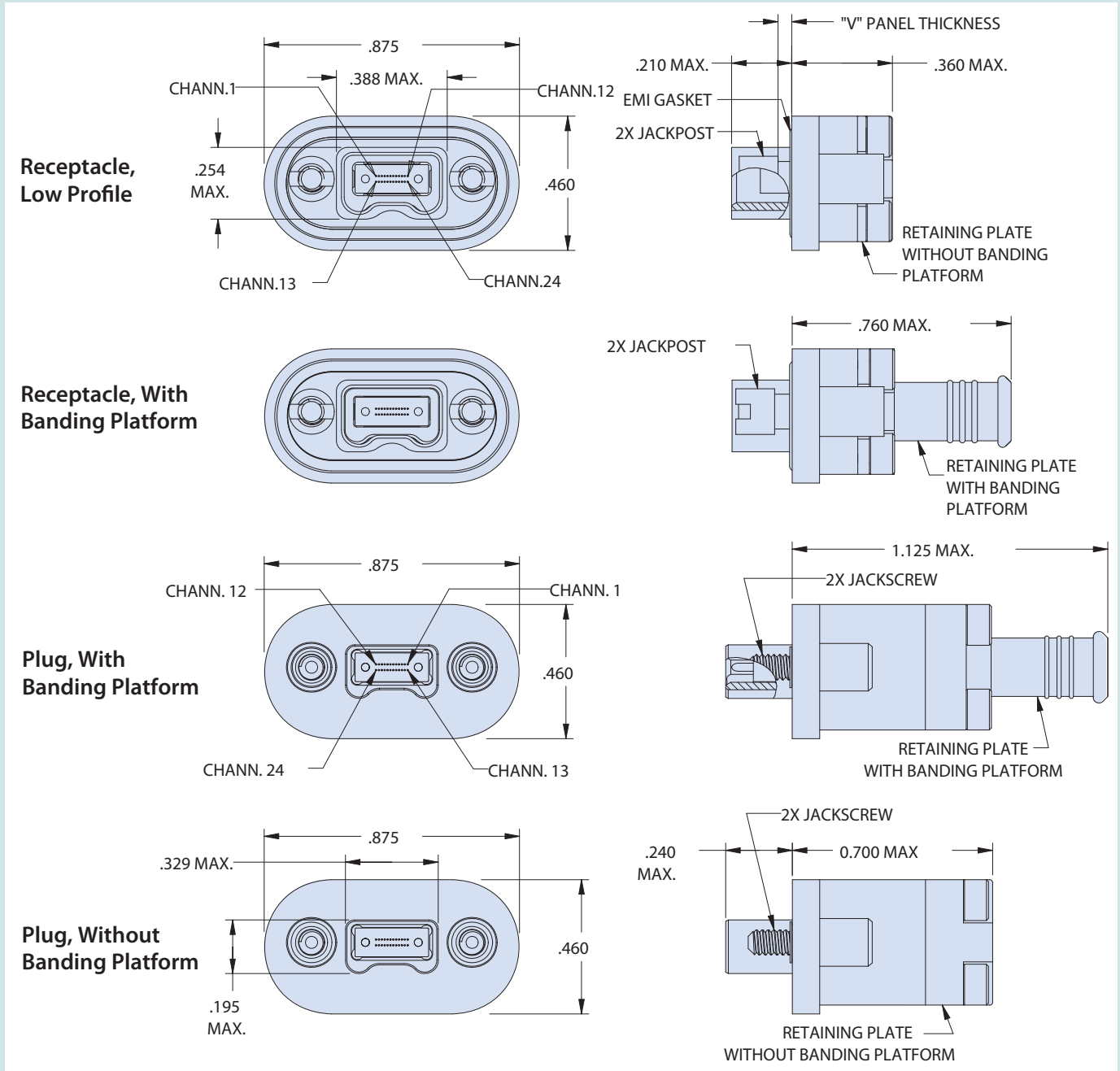

SERIES 79 MINIATURE MT Fiber Optic Connectors

183-014 Environmental Series 79 MT How To Order

How To Order	
Sample Part Number	183-014 ME -06 -L -2 A -APC
Basic Number	Series 79 Single MT Environmental Fiber Optic Connector
Material / Finish	ME = Al Alloy / Electroless Nickel MT = Al Alloy / Nickel PTFE ZR = Al Alloy / Zinc Nickel, Black NF = Al Alloy / Cadmium, O.D. Z1 = Stainless Steel / Passivate
Connector Type	-06 = Plug (used with male MT ferrule) -07 = Receptacle (used with female MT ferrule) -09 = Receptacle with EPDM O-ring (used with female MT ferrule)
Mounting Hardware	Hardware for PLUGS -L = Hex Head Jackscrew, non-removable -K = Slotted Head Jackscrew, non-removable -B = Thru-Hole Rear Panel Mount Jackposts for RECEPTACLES: -X = for .031" panel thickness -W = for .047" panel thickness -V = for .062" panel thickness -T = for .094" panel thickness -R = for .080" panel thickness (panel thickness dims ±.002")
Retaining Plate / Banding Platform	-2 = 12 or 24 channel for plug or receptacle with banding porch -3 = 12 channel for receptacle without banding porch only (N/A for plug) -4 = 24 Channel for receptacle without banding porch only (N/A for plug) -N = No Retaining Plate (For use with standalone retaining plate) See Dwg. 189-165 for various retaining plate designs See Dwg. 189-178 for retaining plate used with Prizm-MT on Jacketed Cable
Polarization Key Position	A or B position for Plug; A, B, or U position for Receptacle Omit for no Polarization Key. See Table.
APC / Flat MT option	-APC = for use with angled MT Ferrule (MT/APC) Omit = for use with flat MT ferrule (MT/PC) including Prizm-MT

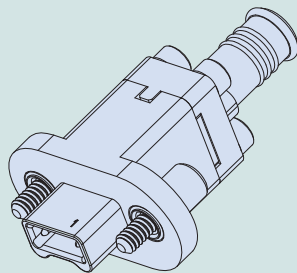

Plug
with Banding Porch

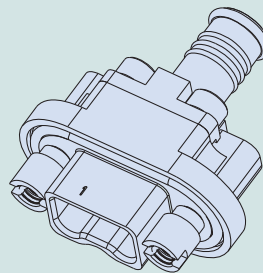

Receptacle
with Banding Porch

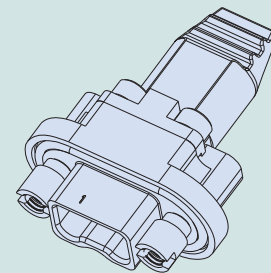

Receptacle
without Banding Porch

Additional Components
181-133 or 181-150 MT Ferrule Kit
601-500 or 601-501 Band-Master ATS® Nano Band for shield termination
189-160 Dust Cap

Seal Materials			
Connector Type	Panel O-Ring	Peripheral Seal	Rear Gasket
-06 Plug	N/A	N/A	Fluorosilicone
-07 Receptacle	Fluorosilicone	Fluorosilicone	Fluorosilicone
-09 Receptacle	EPDM	Fluorosilicone	Fluorosilicone

MATERIAL/FINISH/NOTES

Mounting hardware: stainless steel / passivated

Additional materials, finishes, connector configurations (dual and quad layouts), and hardware options are available, consult factory

Connectors supplied without MT ferrule kit, purchase separately per P/N 181-133 or 181-150

SERIES 79 MINIATURE MT Fiber Optic Connectors



183-014 Environmental Series 79 MT Connector styles and dimensions

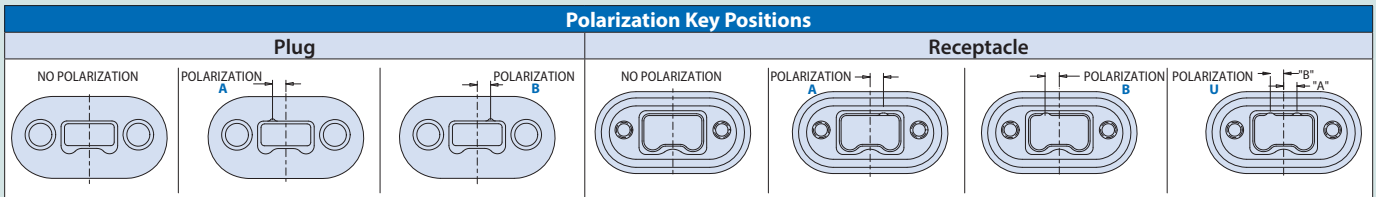
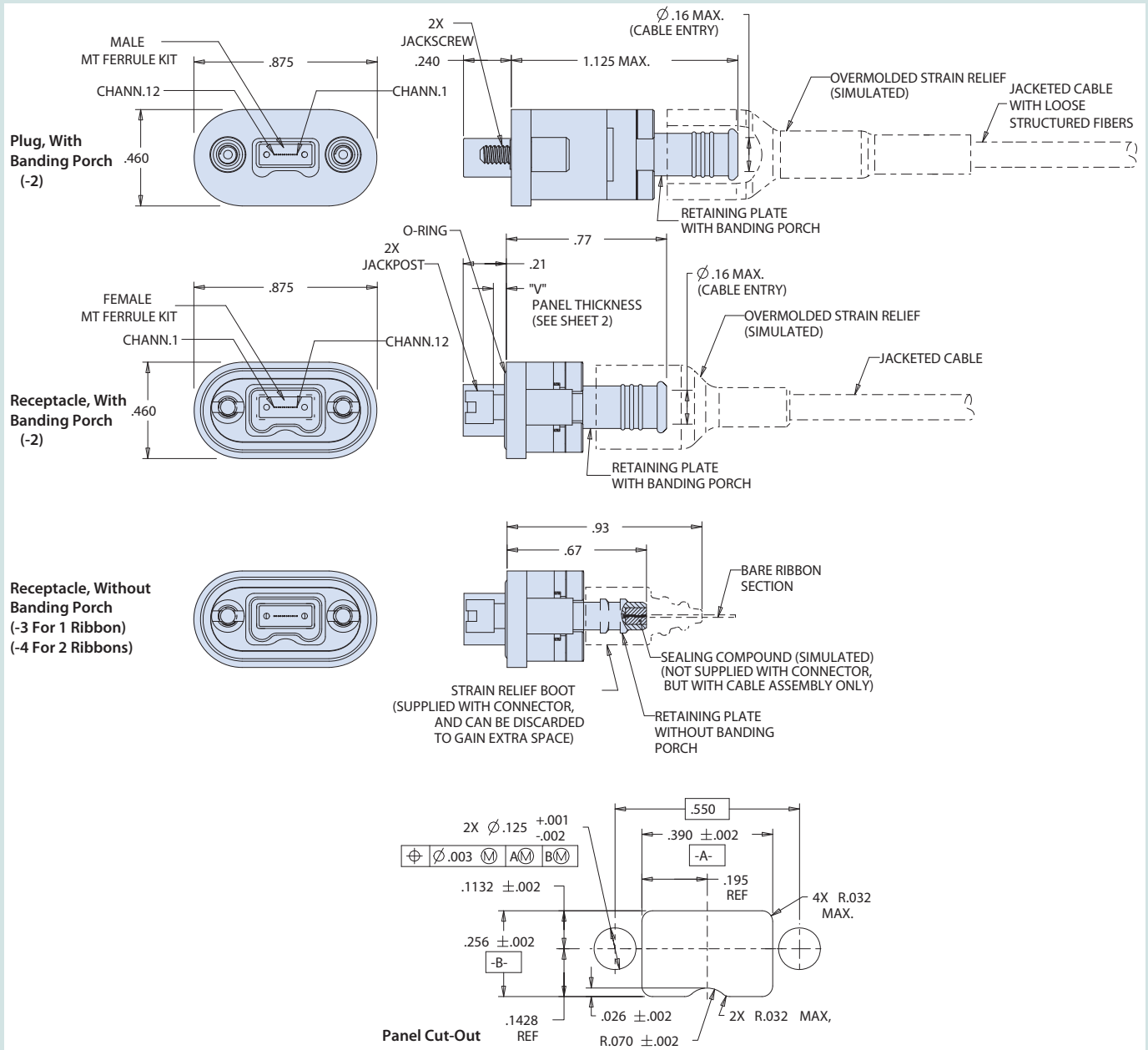

SERIES 79 MINIATURE MT Fiber Optic Connectors

183-021 Series 79 MT with expanded polarized keying positions and #4-40 UNC jackscrew · How To Order

How To Order	
Sample Part Number	183-021 ME -06 -L -1 -A13 -APC
Basic Number	Series 79 Single MT Fiber Optic Connector
Material / Finish	ME = Al Alloy / Electroless Nickel MT = Al Alloy / Nickel PTFE ZR = Al Alloy / Zinc Nickel, Black NF = Al Alloy / Cadmium, O.D. Z1 = Stainless Steel / Passivate
Connector Type	-06 = Plug (used with male MT ferrule) -07 = Receptacle (used with female MT ferrule) -S7 = Receptacle with EMI O-ring (used with female MT ferrule)
Mounting Hardware	Hardware for PLUGS -L = Hex Head Jackscrew, non-removable -B = Thru-Hole Rear Panel Mount Jackposts for RECEPTACLES: -X = for .031" panel thickness -W = for .047" panel thickness -V = for .062" panel thickness -T = for .094" panel thickness -R = for .080" panel thickness (panel thickness dims ±.002")
Retaining Plate / Banding Platform	-1 = 12 or 24 channel without banding porch -2 = 12 or 24 channel with banding porch -N = No Retaining Plate (For use with standalone retaining plate) See Dwg. 189-168 for various retaining plate designs See Dwg. 189-177 for retaining plate used with Prizm-MT on Jacketed Cable
Polarization Key Position	See POLARIZED KEYING POSITIONS Table -U = Universal position for Receptacle only Omit for no Polarization Key. See Table.
APC / Flat MT option	-APC = for use with angled MT Ferrule (MT/APC) Omit = for use with flat MT ferrule (MT/PC) including Prizm-MT

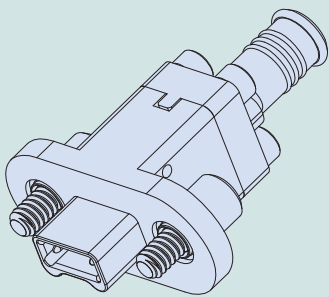

Plug
with Banding Porch

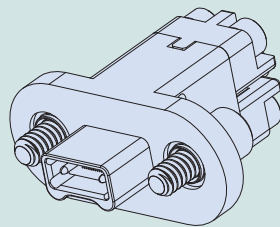

Plug
without Banding Porch

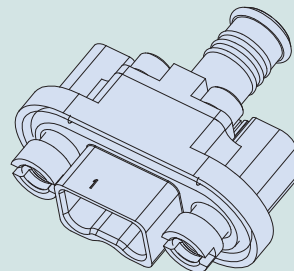

Receptacle
with Banding Porch

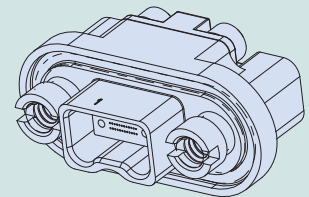

Receptacle
without Banding Porch

Additional Components
181-133 or 181-150 MT Ferrule Kit
601-500 or 601-501 Band-Master ATS® Nano Band for shield termination
189-172 Dust Cap
189-168 or 189-177 Various Retaining Plate Designs

MATERIAL/FINISH/NOTES

Mounting hardware: stainless steel / passivated

EMI O-ring: conductive fluorosilicone Standard O-ring: fluorosilicone/silicone blend

Additional materials, finishes, connector configurations (dual and quad layouts), and hardware options are available, consult factory

Connectors supplied without MT ferrule kit, purchase separately per P/N 181-133 or 181-150

SERIES 79 MINIATURE MT Fiber Optic Connectors



183-021 Series 79 MT with expanded polarized keying positions and #4-40 UNC jackscrew · Connector styles and dimensions

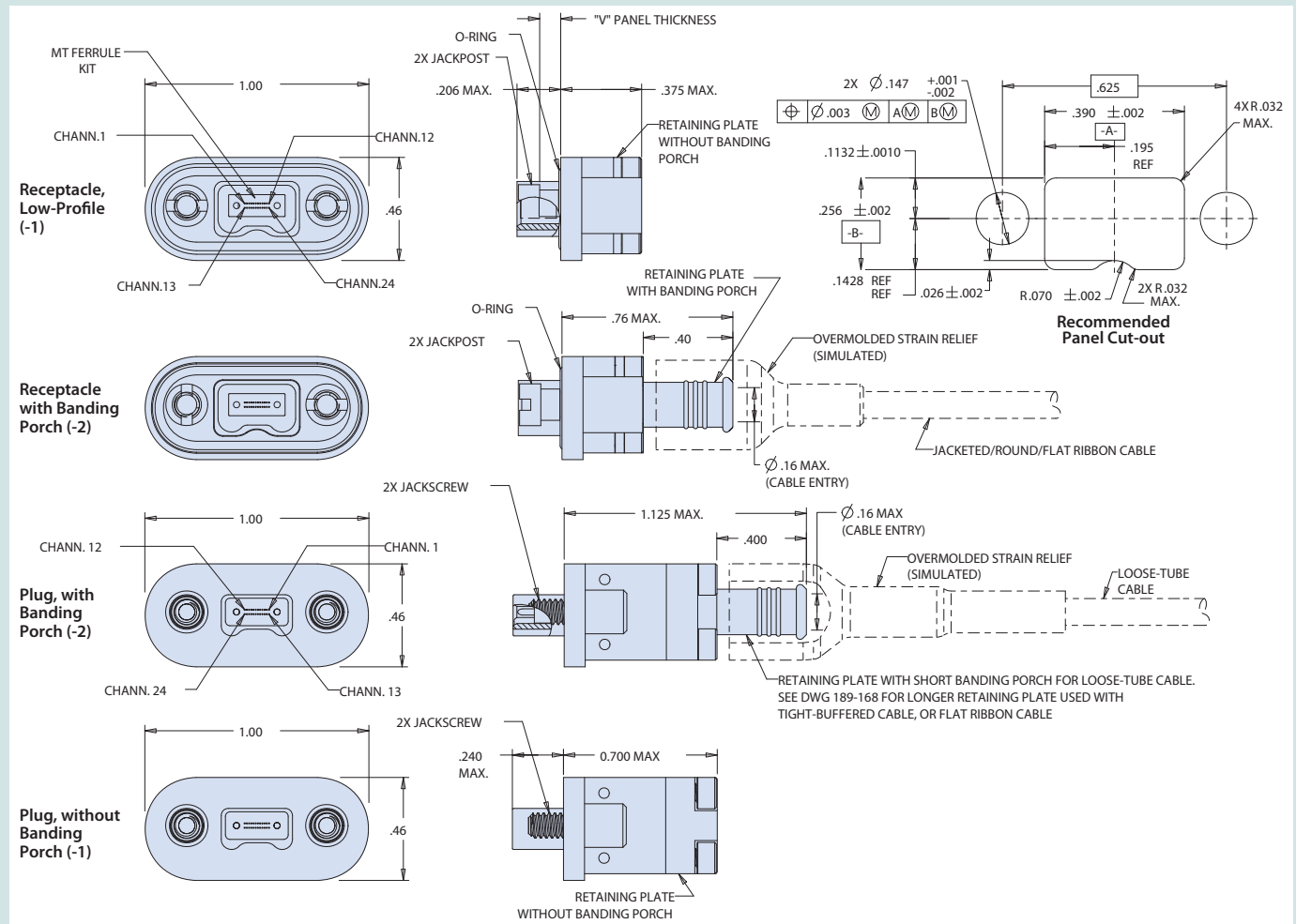

POLARIZED KEYING POSITIONS (Front view, receptacle) CODES and Plug / Receptacle Key Designations

				(Omit) No Polarization Key, Plug			
				-U Universal Key Receptacle			

SERIES 79 MINIATURE MT Fiber Optic Connectors

How To Order MT Ferrule Kits

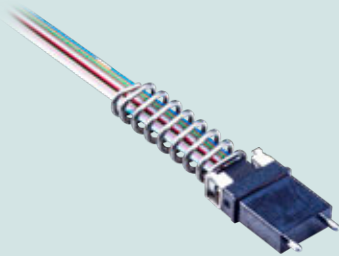

How To Order					
Sample Part Number		181-133	-126	-12	P
Basic Part Number	MT Ferrule kit				
Fiber type	-126, -1253, -1253A (See Table I)				
Number of Fibers	-12, -24 (See Table I)				
Ferrule Style	P = Male (use with Plug) S = Female (use with Receptacle)				

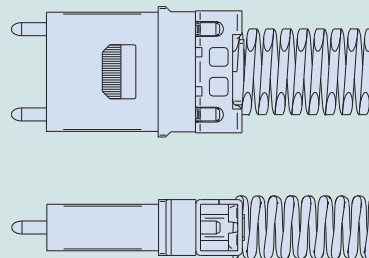

Table I						
Dash No.	Fiber Type	End Face	Fiber Size Core/Cladding	No. of Fibers	Ferrule Identification	Pin Clamp Identification (Male Kit only)
-126	MM	PC	50/125 62.5/125	12 24	M-ME12 M-ME24	1 Through Hole
-1253	SM	PC	9/125	12	E-E12	2 Through Holes
-1253A	SM	APC	9/125	12	E-E12	2 Through Holes

MATERIAL/FINISH

- Ferrule: Polyphenylene Sulfide Resin
- Pin Clamp, Spring: Stainless Steel
- Boot: TPE

SERIES 79 MINIATURE MT Fiber Optic Connectors



How To Order Series 79 MT to MT Ferrule Cable Assembly

How To Order	
Sample Part Number	FA07364 -06 -17 ME -B4 -50 -L -1 -036 L
Basic Number	Series 79 MT Ferrule Fiber Optic Cable Assembly
A Connector Type	-06 = Sr. 79 Plug 183-003 (used with male MT ferrule) -07 = Sr. 79 Receptacle 183-003 (used with female MT ferrule) -S7 = Sr. 79 Receptacle 183-003 with EMI gasket (used with female MT ferrule)
B Connector Type	-06 = Sr. 79 Plug 183-003 (used with male MT ferrule) -07 = Sr. 79 Receptacle 183-003 (used with female MT ferrule) -S7 = Sr. 79 Receptacle 183-003 with EMI gasket (used with female MT ferrule) -12 = ST Connector -13 = FC Connector -14 = SC Connector -15 = GC Connector -16 = LC Connector -17 = MT Connector (male) -18 = MT Connector (female) -19 = MTP Connector (male) -20 = MTP Connector (female)
Material / Finish (-06, -07, -S7)	ME = Al Alloy / Electroless Nickel MT = Al Alloy / Nickel PTFE ZR = Al Alloy / Zinc Nickel, Black NF = Al Alloy / Cadmium, O.D. Z1 = Stainless Steel / Passivate
Fiber Qty. / Type	-B2 = 12 bare ribbon fibers -B4 = 24 bare ribbon fibers -R2 = 12 round ribbon fibers -R4 = 24 round ribbon fibers
Fiber Size	-09 = 9.3/125 Singlemode -50 = 50/125 Multimode -62 = 62.5/125 Multimode
Mounting Hardware (A Connector)	Plug -L = Hex head jackscrew, non-removable -B = Thru-hole Receptacle -X = Rear-panel jackpost, .031" thickness -W = Rear-panel jackpost, .041" thickness -V = Rear-panel jackpost, .062" thickness -T = Rear-panel jackpost, .094" thickness -R = for .080" panel thickness
Mounting Hardware (B Connector, applies to Sr. 79 only)	Series 79 Plug -L = Hex head jackscrew, non-removable -B = Thru-hole -K = Slotted Head Jackscrew, non-removable Series 79 Receptacle -X = Rear-panel jackpost, .031" thickness -W = Rear-panel jackpost, .041" thickness -V = Rear-panel jackpost, .062" thickness -T = Rear-panel jackpost, .094" thickness Omit = if not Sr. 79 connector
Banding Platform (A Connector)	-1 = without banding platform -2 = with banding platform
Banding Platform (B Connector, applies to Sr. 79 only)	-1 = without banding platform -2 = with banding platform Omit if not Sr. 79 connector
Length	In inches (e.g. -0036 = 36 inches)
Protective Cover	L = supplied less covers Omit = supplied with covers

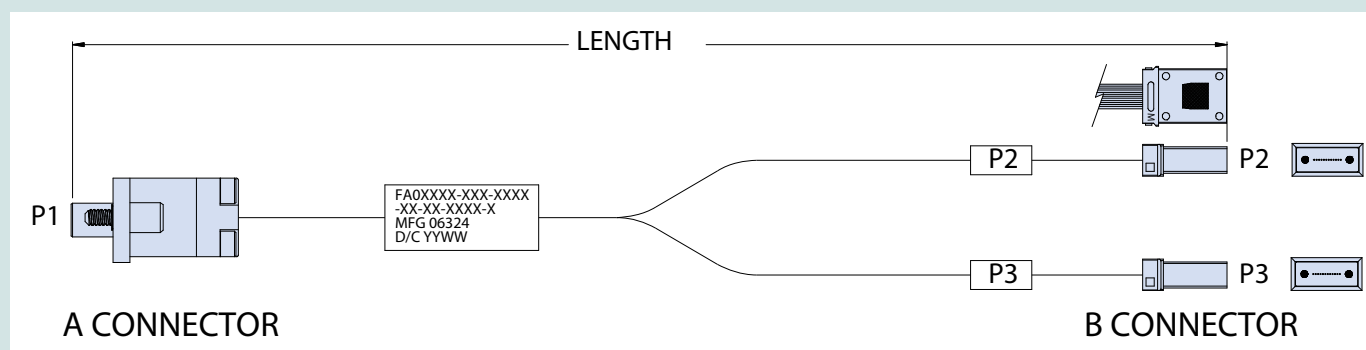

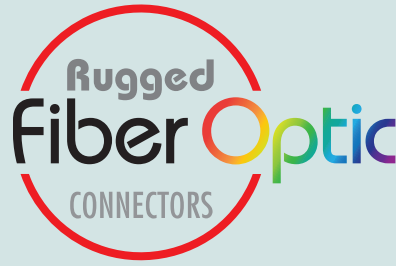

Glenair Front Release (GFR) Fiber Optic Connection System: the Fast Road to Fiber Optic Integration



The Glenair Front Release system allows for rapid connector integration of optical media by placing retention and environmental sealing components directly on the termini. Glenair GFR enables fast design and development of unique fiber optic connector shell packages without costly tooling and engineering.

- Precision size 16 pin-socket front release termini with integrated retention clip
- Singlemode and multimode for all popular fiber sizes
- Typical insertion loss less than 0.5 dB
- Supports cylindrical and rectangular connectors
- Connector shells available in aluminum and stainless steel



GFR fiber optic termini integration in micro miniature rectangular and circular connector packaging

RAPID INTEGRATION

Glenair Front Release (GFR)

Signature fiber optic connection system



Glenair Front Release (GFR) fiber optic connection systems perform at insertion loss levels equivalent to other high-performance, tactical fiber optic systems such as M29504 termini used in D38999 and M28876 connectors. The GFR system enables Glenair to integrate optical media in Micro-D and D-Subminiature shells as well as micro miniature circular packaging. Contact the factory for availability and application engineering assistance for both standard and custom fiber optic connection systems.

GFR GLENAIR FRONT RELEASE MICRO MINIATURE CIRCULAR CONNECTORS



Contact the Factory for circular connectors requiring enhanced vibration and mechanical shock performance

How To Order GFR Micro Miniature Circular Connectors						
Sample Part Number	180-132	M	06-	9-4	P	A
Series	180-132 GFR Micro Miniature Circular					
Shell Size	C	Aluminum Alloy	Anodize, Black			
	M		Electroless Nickel			
	NF		CAD/Olive Drab over Electroless Nickel			
	ZN		Zinc-Nickel/Olive Drab over Electroless Nickel			
	ZNU		Black Zinc-Nickel over Electroless Nickel			
	Z1	Stainless Steel	Passivate			
Connector Style	04- Jam Nut w/ Wire Holes		06- Plug			
	08- Jam Nut Receptacle		07- Wall Mount Receptacle			
Shell Size/Insert Arr.	9-2, 9-4, 13-8, 16-12					
Contact Type	P - Pin Termini S - Socket Termini					
Key Polarization	A, B, C, D (See Table). Omit for 9-2 Arrangement which has 2 Keys/Keyways only.					

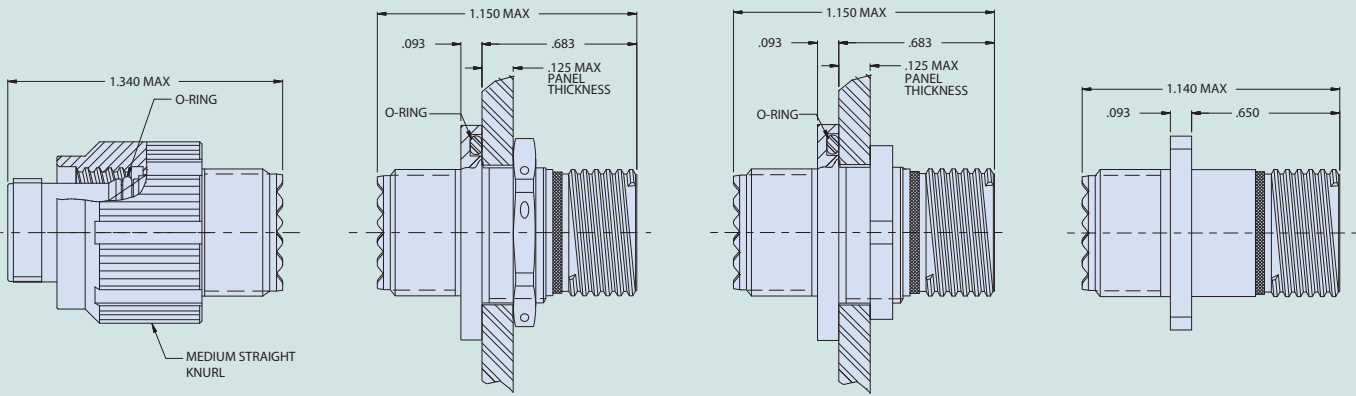

06- Plug

04- Jam Nut Receptacle with Wire Holes

08- Jam Nut Receptacle

07- Wall Mount Receptacle

Key Polarization		
Position	A°	B°
A	150°	210°
B	75°	210°
C	95°	230°
D	140°	275°

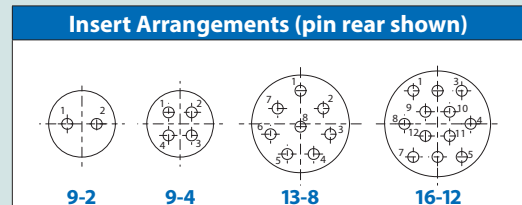

RAPID INTEGRATION Glenair Front Release (GFR)

How to order GFR Termini

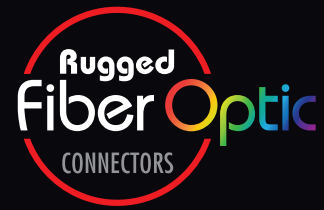

PIN TERMINI

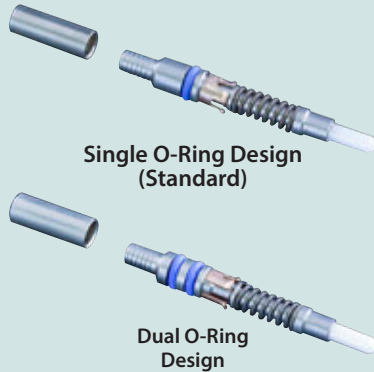

SOCKET TERMINI



DUMMY TERMINUS



How To Order GFR Fiber Optic Termini				
Sample Part Number	181-011	-126	K	D
Series	181-012 GFR front-release pin terminus 181-011 GFR front-release socket terminus			
Dash No.	Dash No.	Ferrule Hole Ø	Typical Fiber Type	Typical Fiber Size core/cladding/coating
	-125	125.5 µm	Singlemode	9/125 µm
	-126S	126.0 µm	Singlemode	9/125 µm
	-126	126.0 µm	Multimode	50/125, 62.5/125 µm
	-142	142.0 µm	Multimode	100/140 µm
	-156	156.0 µm	Multimode	62.5/125/155 µm (Polyimide)
	-173	173.0 µm	Multimode	100/140/172 µm (Polyimide)
	-175	175.0 µm	Multimode	100/140/172 µm (Polyimide)
	-231	231.0 µm	Multimode	200/225 µm
	-236	236.0 µm	Multimode	200/230 µm
-286	286.0 µm	Multimode	200/280 µm	
-448	448.0 µm	Multimode	400/440 µm	
Alignment Sleeve (socket only)	K = Stainless Steel Sleeve Omit = Ceramic Sleeve (standard) Omit designator for pin terminus			
O-Ring Option	D = Dual O-Rings Omit = Single O-Ring (standard)			
Dummy Terminus				
181-051	Size 16 Dummy Terminus for GFR Connectors			

TERMINI MATERIAL AND FINISH

Ferrule: Zirconia Ceramic
 Alignment Sleeve (socket): Zirconia Ceramic or Stainless Steel/Passivate
 Protective Cover (socket): BeCu Alloy/Nickel
 Body: Stainless Steel/Passivate
 Spring (pin): Stainless Steel/Passivate
 Bushing (pin): Stainless Steel/Passivate
 Retention Clip: BeCu Alloy
 O-Ring(s): Fluorosilicone
 Crimp Sleeve: Brass Alloy/Nickel

NOTES

Crimp sleeves are supplied with terminus assemblies. Spares may be ordered separately. See Glenair GAP-031 and GAP-031B for termination and assembly tools/procedures.

Table II: Tools and Accessories	
182-005S	Polishing Tool, socket
182-005P	Polishing Tool, pin
182-012	Crimp Tool
182-013	Insertion Tool, Straight
182-014	Insertion Tool, 90 Degree
182-015	Removal Tool
182-016	Insertion/Removal Tool, Alignment Sleeve, socket
181-011-S	Protective Cover with Ceramic Sleeve
181-011-K	Protective Cover with Stainless Steel Sleeve
265-002	Crimp Sleeve, Ø 2.2mm Max Jacket

RAPID INTEGRATION Glenair Front Release (GFR)



How to order GFR Micro-D and D-Subminiature connectors

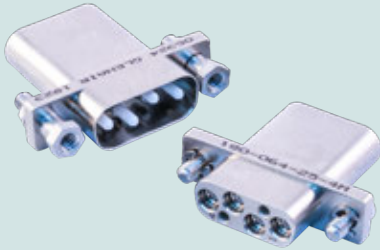

Avoid damage! Consult the factory for mating / unmating instructions



Recommended Panel Cutout

How To Order GFR Micro-D Connectors				
Sample Part Number	180-064	-25	-4	M
Series	180-064 GFR Micro-D Plug			
	180-063 GFR Micro-D Receptacle			
Shell Size	-9 (1 terminus max) -15 (2 termini max) -21 (3 termini max) -25 (4 termini max) -31 (5 termini max) -100 (8 termini max)			
No. of Termini	1, 2, 3, 4, 5, 8			
Material / Finish	C	Aluminum Alloy	Anodize, Black	
	M		Electroless Nickel	
	NF		CAD/Olive Drab over Electroless Nickel	
	ZN		Zinc-Nickel/Olive Drab over Electroless Nickel	
	Z1	Stainless Steel	Passivate	

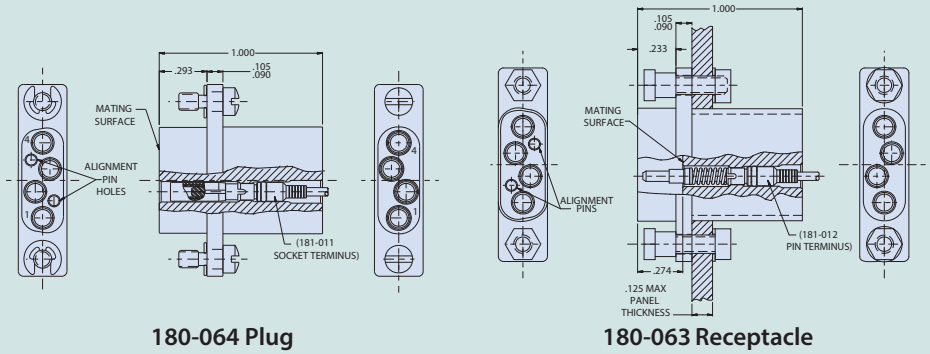

180-064 Plug

180-063 Receptacle



Avoid damage! Consult the factory for mating / unmating instructions

How To Order GFR D-Subminiature Connectors				
Sample Part Number	180-066	-15	-5	-M
Series	180-066 GFR D-Sub Plug			
	180-065 GFR D-Sub Receptacle			
Shell Size	-9 (4 termini max) -15 (5 termini max) -25 (8 termini max) -50 (12 termini max)			
No. of Termini	4, 5, 8, 12			
Material / Finish	C	Aluminum Alloy	Anodize, Black	
	M		Electroless Nickel	
	NF		CAD/Olive Drab over Electroless Nickel	
	ZN		Zinc-Nickel/Olive Drab over Electroless Nickel	
	Z1	Stainless Steel	Passivate	

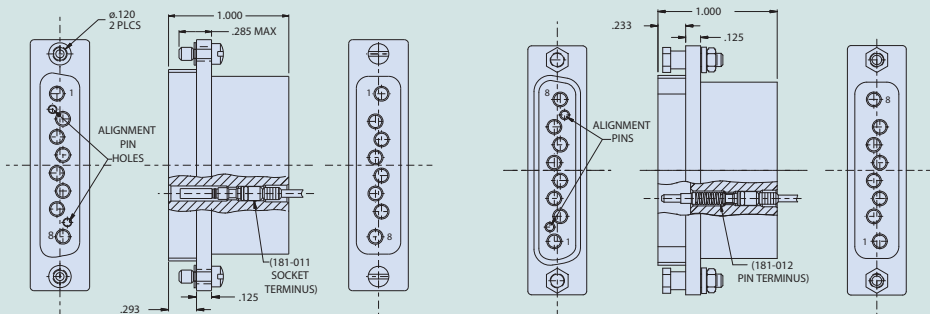

180-066 Plug

180-065 Receptacle

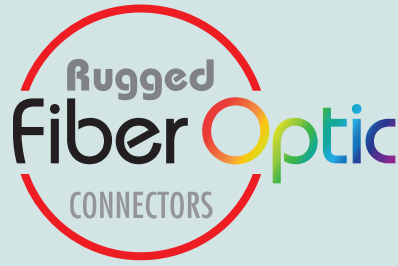

Series 806 Mil-Aero:
Advanced fiber optic
performance, reduced
size and weight

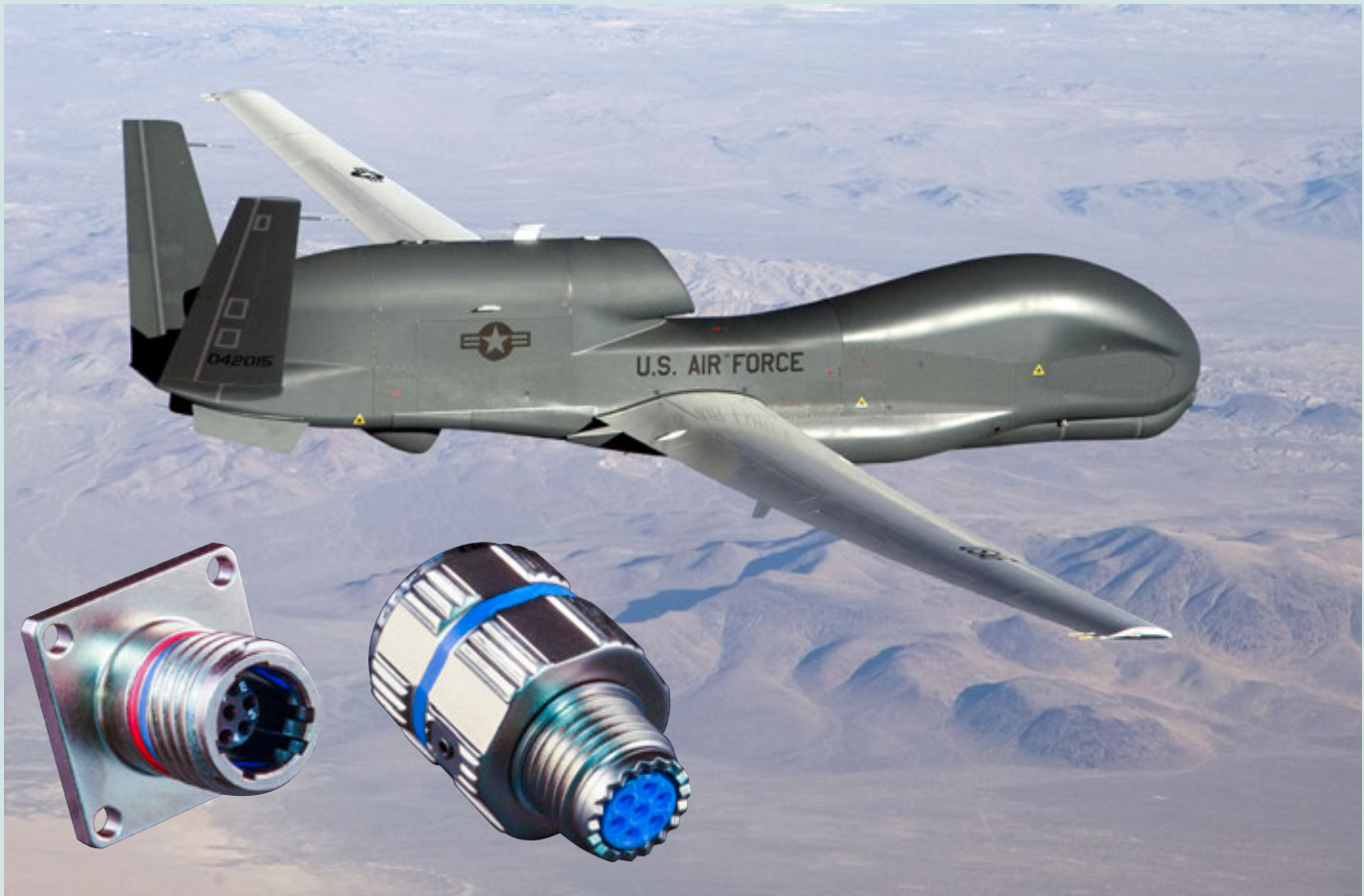

Innovative fiber optic / electrical
connector design meets key performance
benchmarks for harsh vibration, shock, and
environmental settings in rigid conformance
with MIL-DTL-38999 Series III – but at nearly
half the size and weight

- Next-generation small form factor aerospace-grade circular connector
- Designed for harsh application environments such as military and commercial aircraft
- Outstanding environmental, electrical, optical, and mechanical performance
- Integrated anti-decoupling technology
- High density 20HD fiber termini arrangements

SAVE SIZE AND WEIGHT WITH SERIES 806 CONNECTORS

Series 806 Mil-Aero
smallest shell (size 8)
.500 in. mating threads
3 #20 electrical or optical
contacts / termini



MIL-DTL-38999
smallest shell (size 11)
.750 in. mating threads
2 #16 electrical or optical
contacts / termini

ADVANCED-PERFORMANCE MICRO MINIATURE Series 806 Mil-Aero



Signature fiber optic connection system How to order connectors

Series 806 Arrangements compatible with #20HD Fiber Optic Termini

Mating face of pin connector. Socket numbering is reversed.

Symbol ▼ indicates master key location.

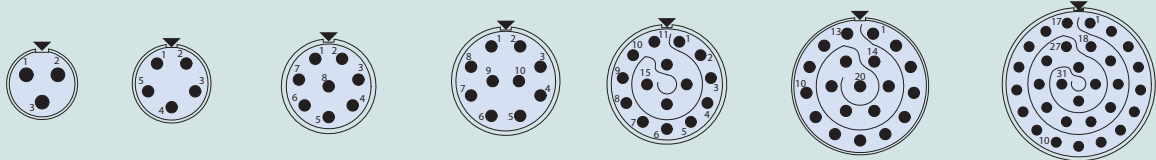

Arrangement No.	8-3	9-5	10-8	11-10	12-15	14-20	16-31
No. of Termini	3	5	8	10	15	20	31

CONNECTOR PLUG AND RECEPTACLE SHELL STYLES FOR #20HD FIBER OPTIC TERMINI



Cable Plug

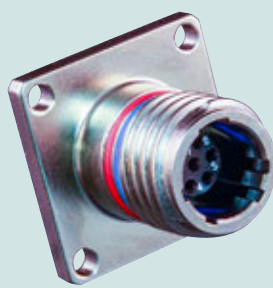

Square-Flange Receptacle

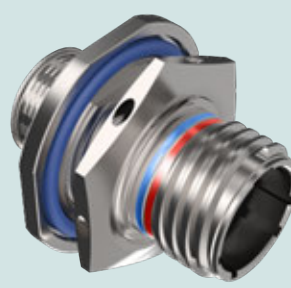

Jam Nut Receptacle

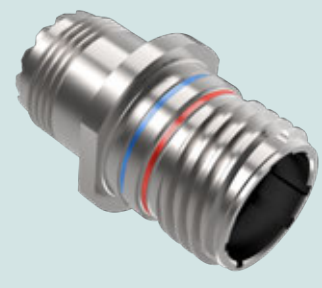

In-Line Receptacle

#20HD FIBER OPTIC TERMINI FOR SERIES 806 MIL-AERO CONNECTORS

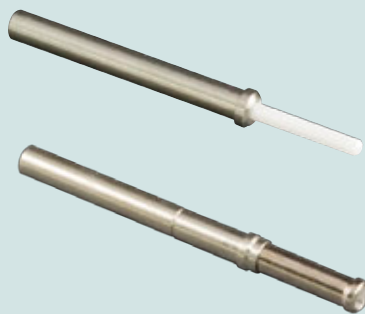

Single or multimode. Ceramic ferrule. 0.5 dB loss. Size 20HD fiber optic termini are compatible with Series 806 connectors with size 20HD contact arrangements. These snap-in, rear release termini feature precision ceramic ferrules and alignment sleeves for accurate fiber alignment. Typical insertion loss 0.5 dB. Fits 50/125 and 62.5/125 multimode and 9/125 singlemode fiber.

How-To-Order #20HD Fiber Optic Termini for Series 806 Connectors

Termini Type	Optical Fiber Type	Part Number	ØA Ferrule Hole	Fiber Size Core/Cladding
Pin	Singlemode	181-134-1255	125.5 microns	9/125
Pin	Multimode	181-134-126	126.0 microns	50/125, 62.5/125
Socket	Singlemode	181-135-1255	125.5 microns	9/125
Socket	Multimode	181-135-126	126.0 microns	50/125, 62.5/125

FACTORY-TERMINATED SERIES 806 FIBER OPTIC CABLE ASSEMBLIES



Glenair is able to supply turnkey fiber optic cable assemblies for both environmental applications as well as non-jacketed harnesses for use inside the box. Rugged Series 806 Mil-Aero with size #20 HD fiber optic termini are a significant size and weight savings compared to conventional D38999 or other standards. Please consult the factory for design assistance and quoting.

ADVANCED-PERFORMANCE MICRO MINIATURE Series 806 Mil-Aero

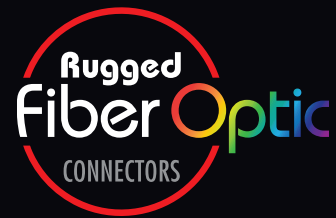

Signature fiber optic connection system How to order connectors



How To Order Series 806 Plugs						
SAMPLE PART NUMBER	806-012	-ME	8-3	A	M	A
Product	806-012 = Cable Plug					
Shell Material and Finish	ME = Aluminum, Electroless Nickel MT = Aluminum, Ni/PTFE ZR = Aluminum, Black Zinc-Nickel NF = Aluminum, Olive Drab Cadmium Z1 = Stainless Steel, Passivated					
Arrangement Number (Shell Size - Insert Arr.)	8-3, 9-5, 10-8, 11-10, 12-15, 14-20, 16-31, (see table on previous page)					
Contact Type	Connector supplied without termini A = Pin B = Socket order fiber optic termini separately					
Shell Style	M = Metric accessory threads B = Nano Band platform					
Polarizing Position (Table 2)	A B C D E F					



How To Order Series 806 Square-Flange Receptacles							
SAMPLE PART NUMBER	806-013	-ME	8-3	B	B	C	A
Product	806-013 = Panel Receptacle, Square Flange						
Shell Material and Finish	ME = Aluminum, Electroless Nickel MT = Aluminum, Ni/PTFE ZR = Aluminum, Black Zinc-Nickel NF = Aluminum, Olive Drab Cadmium Z1 = Stainless Steel, Passivated						
Arrangement Number (Shell Size - Insert Arr.)	8-3, 9-5, 10-8, 11-10, 12-15, 14-20, 16-31, (see table on previous page)						
Contact Type	Connector supplied without termini A = Pin B = Socket order fiber optic termini separately						
Shell Style	M = Metric accessory threads B = Nano Band platform						
Mounting Hole Style	T = Thru holes C = Clinch nut, #4-40 (rear panel mounting)						
Polarizing Position (Table 2)	A B C D E F						

SPECIFICATIONS

- Operating temperature: -55°C to +125°C. Temperature rating depends on the cable and epoxy used.
- Termination method: epoxy/polish
- Mating durability: 500 cycles
- Random vibration: 49.5 Grms, EIA-364-28 Test Condition V. Maximum optical discontinuity 0.5 dB, 50 microseconds.
- Mechanical shock: 300 G, TIA-455-14 Test Condition D. Maximum optical discontinuity 0.5 dB, 50 microseconds.

MATERIAL/FINISH

- Ferrule, alignment sleeve: zirconia ceramic
- Body, shroud: copper/nickel/zinc alloy
- Spring (socket, not shown): stainless steel, passivated
- Protective cover (socket): copper alloy, nickel plated

ADVANCED-PERFORMANCE MICRO MINIATURE Series 806 Mil-Aero



Signature fiber optic connection system How to order connectors

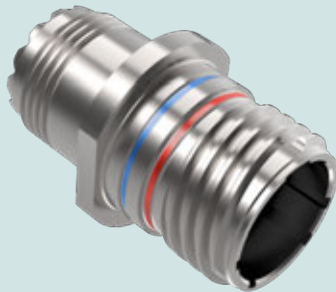

How To Order Series 806 In-Line Receptacles						
SAMPLE PART NUMBER	806-019	-ME	8-3	B	B	A
Product	806-019 = Line Receptacle					
Shell Material and Finish	ME = Aluminum, Electroless Nickel MT = Aluminum, Ni/PTFE ZR = Aluminum, Black Zinc-Nickel NF = Aluminum, Olive Drab Cadmium Z1 = Stainless Steel, Passivated					
Arrangement Number (Shell Size - Insert Arr.)	8-3, 9-5, 10-8, 11-10, 12-15, 14-20, 16-31, (see table on previous page)					
Contact Type	Connector supplied without termini A = Pin B = Socket order fiber optic termini separately					
Shell Style	M = Metric accessory threads B = Nano Band platform					
Polarizing Position (Table 2)	A B C D E F					



How To Order Series 806 Jam Nut Receptacles						
SAMPLE PART NUMBER	806-020	-ME	8-3	B	M	A
Product	806-020 = Jam Nut Receptacle					
Shell Material and Finish	ME = Aluminum, Electroless Nickel MT = Aluminum, Ni/PTFE ZR = Aluminum, Black Zinc-Nickel NF = Aluminum, Olive Drab Cadmium Z1 = Stainless Steel, Passivated					
Arrangement Number (Shell Size - Insert Arr.)	8-3, 9-5, 10-8, 11-10, 12-15, 14-20, 16-31, (see table on previous page)					
Contact Type	Connector supplied without termini A = Pin B = Socket order fiber optic termini separately					
Shell Style	M = Metric accessory threads B = Nano Band platform					
Polarizing Position (Table 2)	A B C D E F					

SPECIFICATIONS

- Operating temperature: -55°C to +125°C. Temperature rating depends on the cable and epoxy used.
- Termination method: epoxy/polish
- Mating durability: 500 cycles
- Random vibration: 49.5 Grms, EIA-364-28 Test Condition V. Maximum optical discontinuity 0.5 dB, 50 microseconds.
- Mechanical shock: 300 G, TIA-455-14 Test Condition D. Maximum optical discontinuity 0.5 dB, 50 microseconds.

MATERIAL/FINISH

- Ferrule, alignment sleeve: zirconia ceramic
- Body, shroud: copper/nickel/zinc alloy
- Spring (socket, not shown): stainless steel, passivated
- Protective cover (socket): copper alloy, nickel plated

GLENAIR
SIGNATURE
FIBER OPTIC
CONNECTION
SYSTEMS

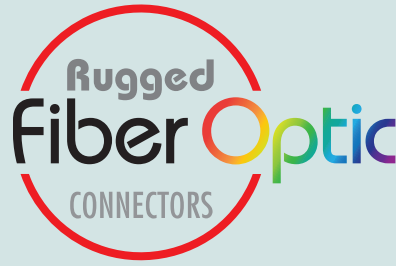

Glenair High Density (GHD): nearly double the density of standard mil-spec fiber optic designs

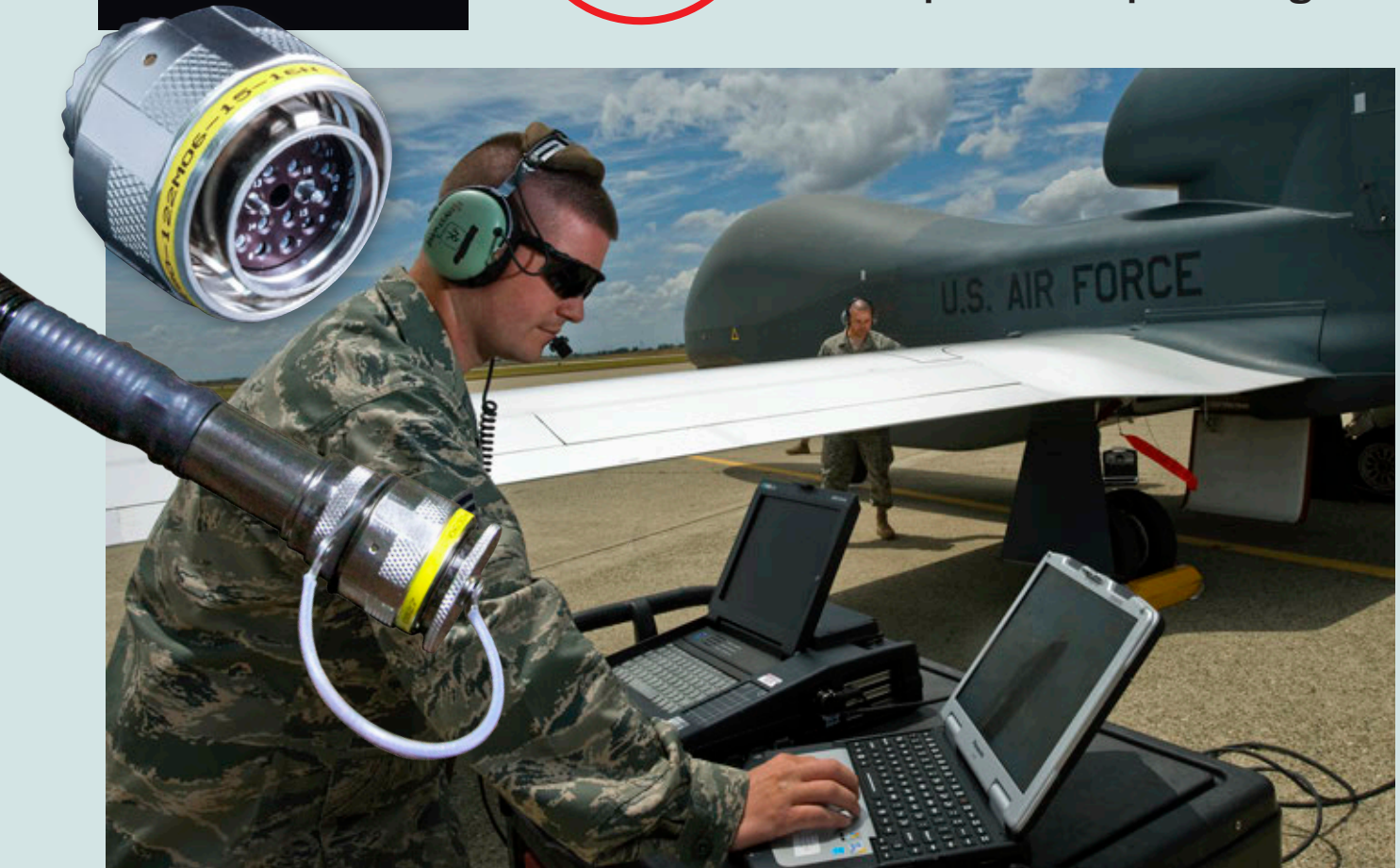

The system of choice for military and commercial air and space applications. Outstanding optical and environmental performance with nearly double the density of standard mil-spec, butt-joint solutions.

- Innovative #18 (1.25mm ferrule) front-release genderless termini accommodate 900 μ to 2.0mm jacketed fiber
- M85045/16 cable accommodation
- Composite, aluminum or stainless steel shells
- Single key termini for APC polish available
- Better optical performance than D38999 with nearly double the density
- Precision alignment sleeve retainer with integrated guide pins



GHD plug connector with alignment sleeve retainer, and square flange receptacle. Termini available in keyed and non-keyed styles

SIZE- AND WEIGHT- SAVING Glenair High Density (GHD)



Signature HD fiber optic connection system

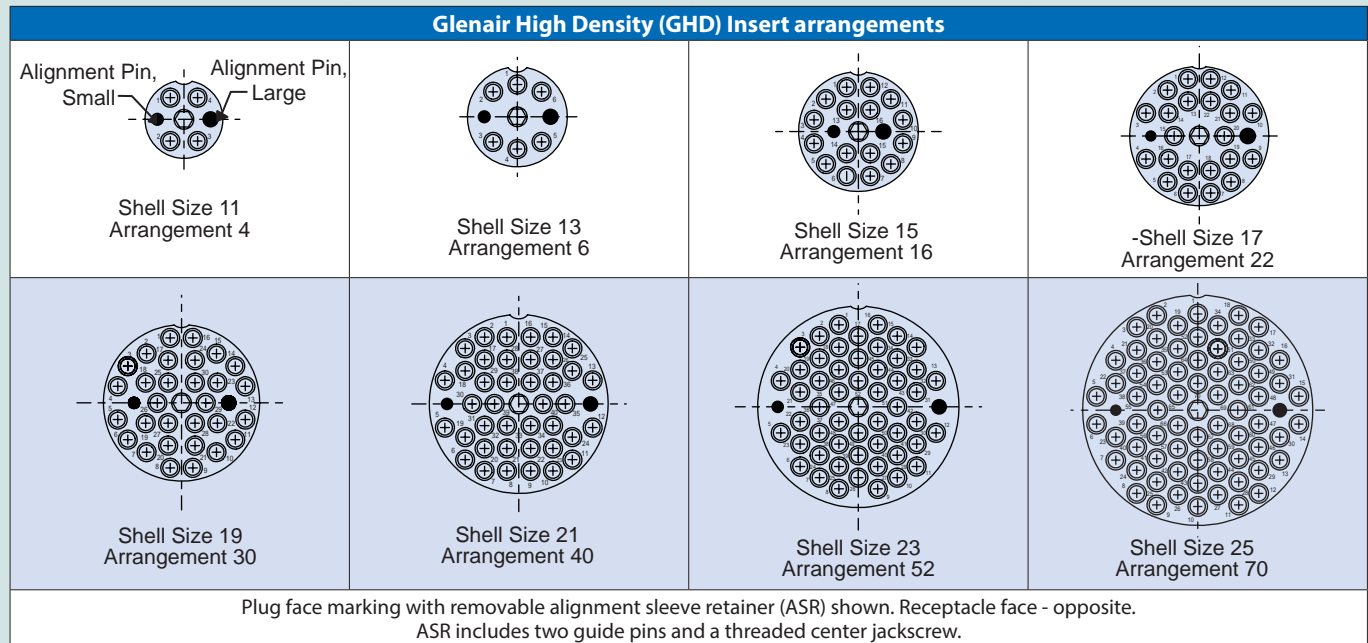

Fiber Optic Pin Termini Specifications			
Assembly Dash Number		Fiber Size	A Dia.
Keyed	Non-Keyed	Core/Cladding	[microns]
181-047-1255C	181-056-1255C	9/125 (Singlemode)	125.5
181-047-1260C	181-056-1260C	9/125, 50/125, 62.5/125	126.0
181-047-1270C	181-056-1270C	50/125, 62.5/125	127.0
181-047-1420C	181-056-1420C	100/140	142.0
181-047-1450C	181-056-1450C	100/140	145.0
181-047-1560C	181-056-1560C	62.5/125/155 (Polyimide)	156.0
181-047-1570C	181-056-1570C	62.5/125/155 (Polyimide)	157.0
181-047-1730C	181-056-1730C	100/140/172 (Polyimide)	173.0
181-047-1750C	181-056-1750C	100/140/172 (Polyimide)	175.0
181-047-2360C	181-056-2360C	200/233	236.0
181-047-2860C	181-056-2860C	200/280	286.0

Crimp Sleeve is supplied with Terminus Assembly, and may be ordered separately. For terminus less crimp sleeve, omit **C** from end of part number (e.g. 181-056-1260)

Table I: Material and Finish		
Code	Material	Finish Description
M	Aluminum Alloy	Electroless Nickel
MT		Nickel - PTFE, Grey
NF		Cadmium, Olive Drab
ZNU		Zinc-Nickel, Black
ZR		Zinc-Nickel, Black (RoHS)
XM	Composite	Electroless Nickel
XMT		Nickel - PTFE, Grey
XW		Cadmium, Olive Drab
XZN		Zinc-Nickel, Black
ZL	Stainless Steel	Electro-Deposited Nickel
Z1		Passivate

GHD Fiber Optic Part Number Reference	
Glenair Dwg. Number	Product Description
181-047	#18 Pin Terminus, Keyed for APC Polish
181-056	#18 Pin Terminus, non-keyed (standard)
181-058	#18 Dummy Terminus
180-122 (05)	In-Line Receptacle Connector
180-122 (06)	Plug Connector with Alignment Sleeve Retainer
180-122 (08)	Jam Nut Mount Receptacle Connector
180-122 (H7)	Square Flange Receptacle with Round Holes
180-122 (S7)	Square Flange Receptacle with Slotted Holes

* See fiber optic catalog for complete part number information

Pin Density Comparison: Glenair High Density Versus D38999 and M28876								
Connector Style / Size	11	13	15	17	19	21	23	25
D38999 Cavity Count	2	4	5	8	11	16	21	29/37
M28876 Cavity Count	2	4	8	N/A	N/A	N/A	31	N/A
GHD Cavity Count	4	6	16	22	30	40	52	70

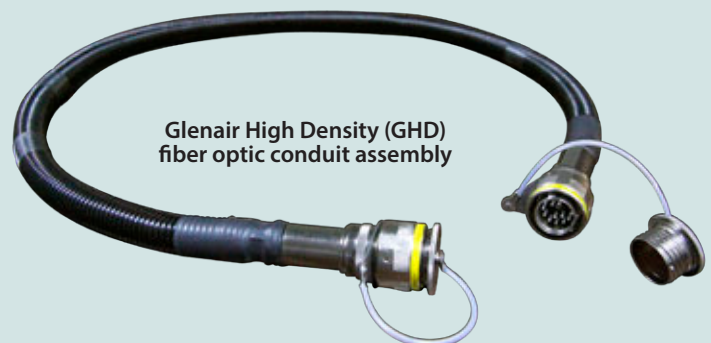

SIZE- AND WEIGHT- SAVING Glenair High Density (GHD)

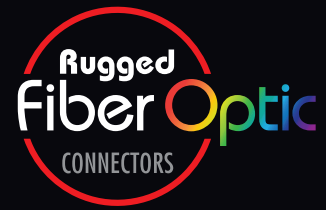

Signature HD fiber optic connection system How to order connectors

Part Number Development					
Sample Part Number	180-122	NF	06	-15-16	N C
Series / Basic Part No.	Glenair High Density Fiber Optic Connector				
Material/Finish	See Material/Finish Table				
Connector Style	06 = Plug with Alignment Sleeve Retainer				
Shell Size/Insert Arr.	11-4, 13-6, 15-16, 17-22, 19-30, 21-40, 23-52, 25-70				
Alternate Key Position*	A, B, C, D, E, N = Normal				
O-Ring Option	C = Conductive O-Ring Omit = Standard O-Ring				

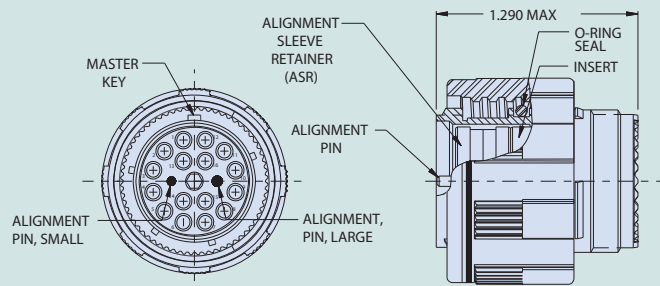

Part Number Development			
Sample Part Number	180-122	ASR	-15-16
Series / Basic Part No.	Glenair High Density Fiber Optic Connector		
Connector Style	ASR = Alignment Sleeve Retainer		
Shell Size/Insert Arr.	11-4, 13-6, 15-16, 17-22, 19-30, 21-40, 23-52, 25-70		

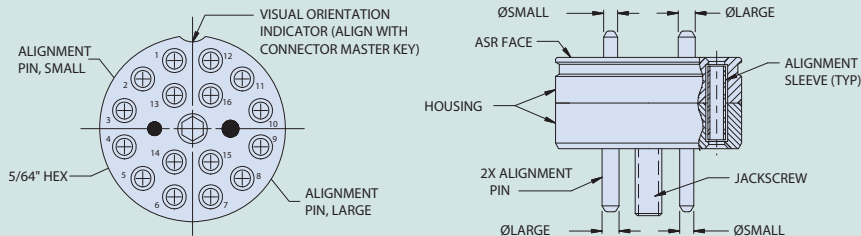

Part Number Development					
Sample Part Number	180-122	NF	08	-15-16	N
Series / Basic Part No.	Glenair High Density Fiber Optic Connector				
Material/Finish	See Material/Finish Table				
Connector Style	08 = Jam Nut Receptacle				
Shell Size/Insert Arr.	11-4, 13-6, 15-16, 17-22, 19-30, 21-40, 23-52, 25-70				
Alternate Key Position*	A, B, C, D, E, N = Normal				

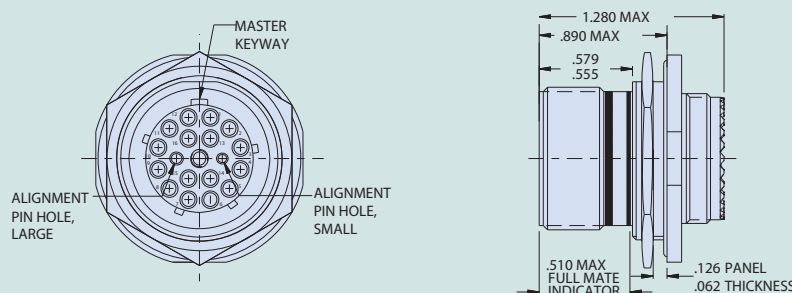

SIZE- AND WEIGHT- SAVING Glenair High Density (GHD)



Signature HD fiber optic connection system How to order connectors

Part Number Development					
Sample Part Number	180-122	NF	05	-15-16	N
Series / Basic Part No.	Glenair High Density Fiber Optic Connector				
Material/Finish	See Material/Finish Table				
Connector Style	05 = In-Line Receptacle				
Shell Size/Insert Arr.	11-4, 13-6, 15-16, 17-22, 19-30, 21-40, 23-52, 25-70				
Alternate Key Position*	A, B, C, D, E, N = Normal				

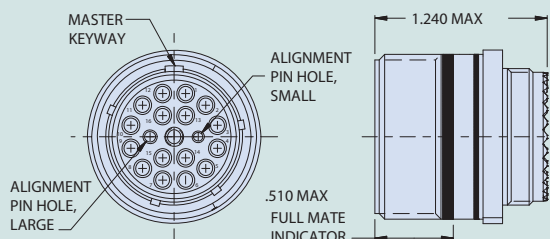

Part Number Development					
Sample Part Number	180-122	NF	H7	-15-16	N
Series / Basic Part No.	Glenair High Density Fiber Optic Connector				
Material/Finish	See Material/Finish Table				
Connector Style	H7 = Wall Mount Receptacle with Round Holes				
Shell Size/Insert Arr.	11-4, 13-6, 15-16, 17-22, 19-30, 21-40, 23-52, 25-70				
Alternate Key Position*	A, B, C, D, E, N = Normal				

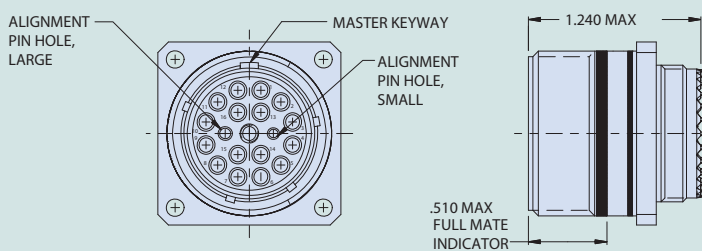

Part Number Development					
Sample Part Number	180-122	NF	S7	-15-16	N
Series / Basic Part No.	Glenair High Density Fiber Optic Connector				
Material/Finish	See Material/Finish Table				
Connector Style	S7 = Wall Mount Receptacle with Slotted Holes				
Shell Size/Insert Arr.	11-4, 13-6, 15-16, 17-22, 19-30, 21-40, 23-52, 25-70				
Alternate Key Position*	A, B, C, D, E, N = Normal				

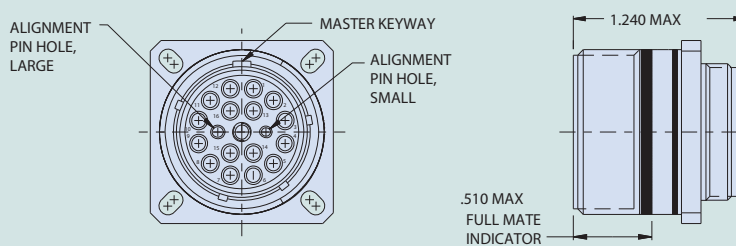

GLENAIR
SIGNATURE
FIBER OPTIC
CONNECTION
SYSTEMS

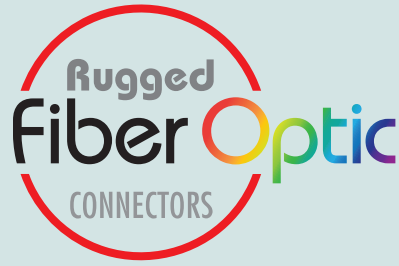

SuperNine®
Tight-Tolerance
MIL-DTL-38999 Sr. III
Fiber Optic Connection
System



The high-performance D38999 type fiber optic interconnect system with qualified MIL-PRF-29504 /4 and /5 termini, successfully deployed in hundreds of commercial and military aerospace and other applications — from F-16 upgrade systems to the revolutionary F-35 Joint Strike Fighter.

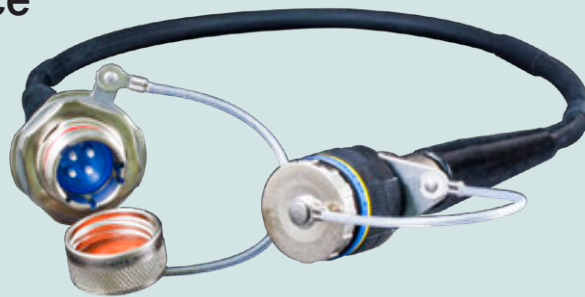

Terminated and tested point-to-point and multibranch D38999 type fiber optic cable assemblies

- Composite, aluminum and stainless steel shells available
- Qualified size #16 MIL-PRF-29504 /4 and /5 precision ceramic termini
- Singlemode and multimode fiber, from 9/125 to 1000 microns
- Ultra-low insertion loss, <.50dB typical
- From 2 to 37 Termini
- Plug and In-Line, Jam Nut and Square Flange Receptacles
- Patented MIL-DTL-38999 fiber optic test probes and adapters

SuperNine® TIGHT-TOLERANCE MIL-DTL-38999 Series III Type



Advanced fiber optic connection system



MIL-DTL-38999 type fiber optic connection system termination, inspection, test, and cleaning tools are available now from Glenair. We also offer comprehensive F/O training services for assembly and maintenance technicians.

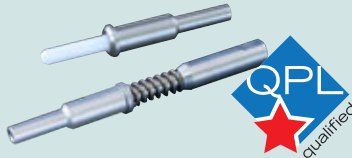

Glenair M29504/04 and /05 QPL termini are in stock and ready for immediate, same-day shipment

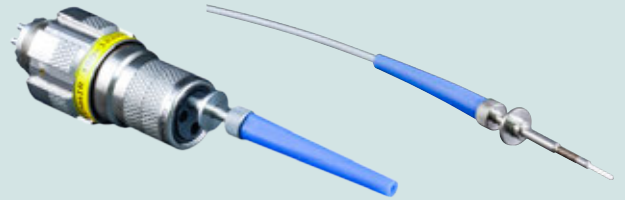

Glenair optical fiber test probes and connector adapters provide accurate and repeatable testing of MIL-DTL-38999 F/O assemblies



Hybrid electrical/optical layouts are available including the MIL-STD-1560 17-8 layout shown above



A complete range of metal and composite backshells and protective covers is available



Eye-Beam GLT termini and jumpers are easily integrated into Glenair MIL-DTL-38999 type connector packaging

MIL-PRF-29504/04 and /05 Fiber Optic Termini Performance Data	
Test Type	Performance Requirement
Operating Temperature	-55°C to +165°C (dependent on epoxy and cable)
Temperature Cycling	-65°C to +175°C
Thermal Shock	-55°C to +150°C, 5 cycles
Temperature Life	+150°C for 1,000 hours
Random Vibration	20-2,000 Hz, 42.2 g's
Shock (Half-sine Pulse)	300 g Peak Load
Mechanical Shock	MIL-S-901, Grade A, Type B, Class I
Mating Durability	500 cycles (cleaning after 100 matings)
Salt Spray	48 hours (Terminus only)
Cable Retention Force	22.0 lbs (dependent on cable construction)

Table I: Material and Finish		
Code	Material	Finish Description
M	Aluminum Alloy	Electroless Nickel
MT		Nickel - PTFE, Grey
NF		Cadmium, Olive Drab
ZNU		Zinc-Nickel, Black
ZR		Zinc-Nickel, Black (RoHS)
XM	Composite	Electroless Nickel
XMT		Nickel - PTFE, Grey
XW		Cadmium, Olive Drab
XZN		Zinc-Nickel, Black
ZL	Stainless Steel	Electro-Deposited Nickel
Z1		Passivate

INSERT ARRANGEMENTS

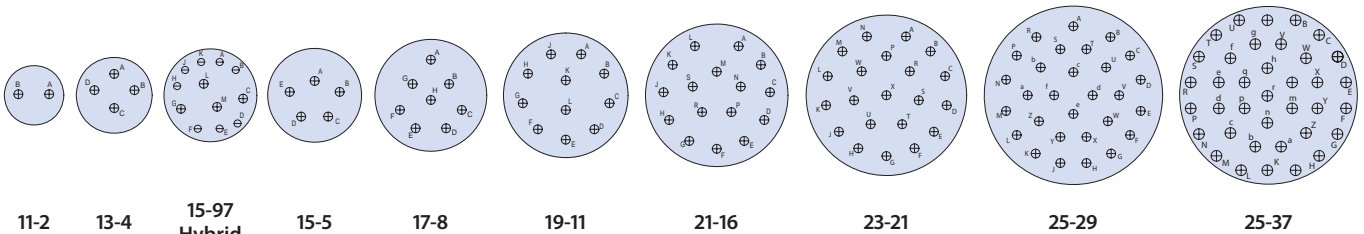

Per MIL-STD-1560. Mating face of pin insert shown.

SuperNine® TIGHT-TOLERANCE MIL-DTL-38999 Series III Type

How to order Termini and Connectors

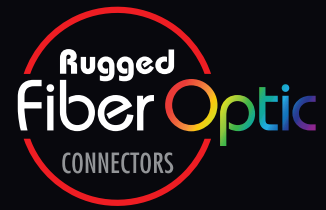

M29504/04 AND /05 TYPE, STYLE 1 PIN AND SOCKET TERMINI FOR MIL-DTL-38999 SERIES III



181-002-XXX
Pin Terminus



181-001-XXX
Socket Terminus



181-048-16
Size 16 Dummy Terminus
reduces weight and cost versus
standard termini

Part Number	Fiber Size Core/Cladding/ Coating (Microns)	Ferrule Hole Size	Ref. M29504/04-XXXX	Ref. M29504/05-XXXX
181-00X-125	9/125 (Singlemode)	125.5	M29504/04-4208	M29504/05-4237
181-00X-126S	9/125 (Singlemode)	126.0	M29504/04-4209	M29504/05-4238
181-00X-126	50/125 & 62.5/125	126.0	M29504/04-4210	M29504/05-4239
181-00X-127	50/125 & 62.5/125	127.0	M29504/04-4040	M29504/05-4046
181-00X-142	100/140	142.0	M29504/04-4043	M29504/05-4049
181-00X-144	100/140	144.0	N/A	N/A
181-00X-145	100/140	145.0	M29504/04-4044	M29504/05-4050
181-00X-156	62.5/125/155 (Polyimide)	156.0	M29504/04-4211	M29504/05-4240
181-00X-157	62.5/125/155 (Polyimide)	157.0	M29504/04-4212	M29504/05-4241
181-00X-173	100/140/172 (Polyimide)	173.0	M29504/04-4087	M29504/05-4088
181-00X-175	100/140/172 (Polyimide)	175.0	M29504/04-4213	M29504/05-4242
181-00X-231	200/230	231.0	N/A	N/A
181-00X-236	200/230	236.0	N/A	M29504/05-4243
181-00X-286	200/280	286.0	N/A	M29504/05-4244
181-00X-448	400/440	448.0	N/A	M29504/05-4245
181-00X-533	486/500	533.0	N/A	N/A

SUPERNINE FIBER OPTIC CONNECTORS



Part Number Development						
Sample Part Number	180-091	XW	06	-17-8	P	N
Series / Basic Part No.	D38999 Series III Type					
Material/Finish	See Material/Finish Table					
Connector Style	06 = Plug Connector					
MIL-STD-1560 Shell Size/Insert Arr.	11-2, 13-4, 15-97 (combo), 17-8, 19-11, 21-16, 23-21, 25-29, 25-37					
Insert Designation	P = Pin S = Socket					
Alternate Key Position*	A, B, C, D, E, N = Normal; Per MIL-DTL-38999					



Part Number Development						
Sample Part Number	180-091	XW	05	-17-8	P	N
Series / Basic Part No.	D38999 Series III Type					
Finish	See Material/Finish Table					
Connector Style*	05 = In-Line Receptacle					
MIL-STD-1560 Shell Size/Insert Arr.	11-2, 13-4, 15-97 (combo), 17-8, 19-11, 21-16, 23-21, 25-29, 25-37					
Insert Designation	P = Pin S = Socket					
Alternate Key Position*	A, B, C, D, E, N = Normal; Per MIL-DTL-38999					

SuperNine® TIGHT-TOLERANCE MIL-DTL-38999 Series III Type



How to order Connectors

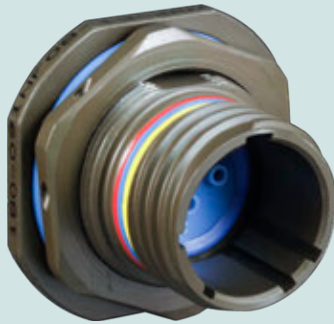

Part number development						
Sample Part Number	180-091	XW	08	-17-8	P	N
Series / Basic Part No.	D38999 Series III Type					
Material/Finish	See Material/Finish Table					
Connector Style	08 = Jam Nut Receptacle					
MIL-STD-1560 Shell Size/Insert Arr.	11-2, 13-4, 15-97 (combo), 17-8, 19-11, 21-16, 23-21, 25-29, 25-37					
Insert Designation	P = Pin S = Socket					
Alternate Key Position*	A, B, C, D, E, N = Normal; Per MIL-DTL-38999					



Part number development						
Sample Part Number	180-091	XW	H7	-17-8	P	N
Series / Basic Part No.	D38999 Series III Type					
Material/Finish	See Material/Finish Table					
Connector Style	H7 = Wall Mount Receptacle with Round Holes (Std)					
MIL-STD-1560 Shell Size/Insert Arr.	11-2, 13-4, 15-97 (combo), 17-8, 19-11, 21-16, 23-21, 25-29, 25-37					
Insert Designation	P = Pin S = Socket					
Alternate Key Position*	A, B, C, D, E, N = Normal; Per MIL-DTL-38999					



Part number development						
Sample Part Number	180-091	XW	S7	-17-8	P	N
Series / Basic Part No.	D38999 Series III Type					
Material/Finish	See Material/Finish Table					
Connector Style	S7 = Wall Mount Receptacle with Slotted Holes					
MIL-STD-1560 Shell Size/Insert Arr.	11-2, 13-4, 15-97 (combo), 17-8, 19-11, 21-16, 23-21, 25-29, 25-37					
Insert Designation	P = Pin S = Socket					
Alternate Key Position*	A, B, C, D, E, N = Normal; Per MIL-DTL-38999					



Part number development						
Sample Part Number	180-091	XW	T7	-17-8	P	N
Series / Basic Part No.	D38999 Series III Type					
Material/Finish	See Material/Finish Table					
Connector Style	T7 = Wall Mount Receptacle with Threaded Insert Holes					
MIL-STD-1560 Shell Size/Insert Arr.	11-2, 13-4, 15-97 (combo), 17-8, 19-11, 21-16, 23-21, 25-29, 25-37					
Insert Designation	P = Pin S = Socket					
Alternate Key Position*	A, B, C, D, E, N = Normal; Per MIL-DTL-38999					



Commercial and military aerospace fiber optic connection system designed for RF-over-fiber, in-flight entertainment, avionics, and other high-speed data networking applications. Utilizing D38999 Series III type connectors, Glenair ARINC 801 features genderless termini, a removable alignment sleeve retainer, and singlemode or multimode 1.25mm termini for low insertion loss performance and flexibility in cable choice.

- Genderless terminus design eliminates pin and socket complexity
- Rear-release size #16 termini
- Singlemode and multimode
- Mechanical and environmental performance IAW ARINC 801 standards



Table I: Material and Finish		
Code	Material	Finish Description
M	Aluminum Alloy	Electroless Nickel
MT		Nickel - PTFE, Grey
NF		Cadmium, Olive Drab
ZN		Zinc-Nickel, Olive Drab
ZR		Zinc-Nickel, Black (RoHS)
XM	Composite	Electroless Nickel
XMT		Nickel - PTFE, Grey
XW		Cadmium, Olive Drab
XZN		Zinc-Nickel, Black
ZL	Stainless Steel	Electro-Deposited Nickel
Z1	Steel	Passivate

Series 180-159 ARINC 801 Performance Specifications	
Test Description	Performance Requirements/Specifications
Insertion Loss	Multimode (PC): 0.30 dB typical at 850/1300nm
	Singlemode (UPC): 0.30 dB typical at 1310/1550nm
Return Loss	Multimode (PC): Better than 20 dB
	Singlemode (UPC): Better than 40 dB
Operating Temperature	-55°C to +165°C (cable/epoxy dependent)
Storage Temperature	-40°C to +85°C (cable/epoxy dependent)
Mating Durability	500 cycles, per TIA/EIA-455-21
Vibration	23.1g RMS, 8 hrs/axis, per TIA/EIA-455-11, Test Condition VI-G
Mechanical Shock (half-sine pulse)	300g Peak for 3ms, 3 shocks/axis in each direction, per TIA/EIA-455-14, Test Condition D
Thermal Cycling	-55°C to +125°C, 50 cycles, per TIA/EIA-455-3, Test Condition C-4 (cable/epoxy dependent)
Temperature Life	+125°C for 1000 hrs, per TIA/EIA-455-4 (cable/epoxy dependent)
Humidity, Steady State	+40°C for 240 hrs, 90% RH, per TIA/EIA-455-5, Method A, Test Condition B
Humidity, Temperature Cycling	-25°C to +65°C, 10 cycles for 24 hrs, 90% RH, per TIA/EIA-455-5, Method B7a (cable/epoxy dependent)

FIGURE 1: ARINC 801 INSERT ARRANGEMENTS

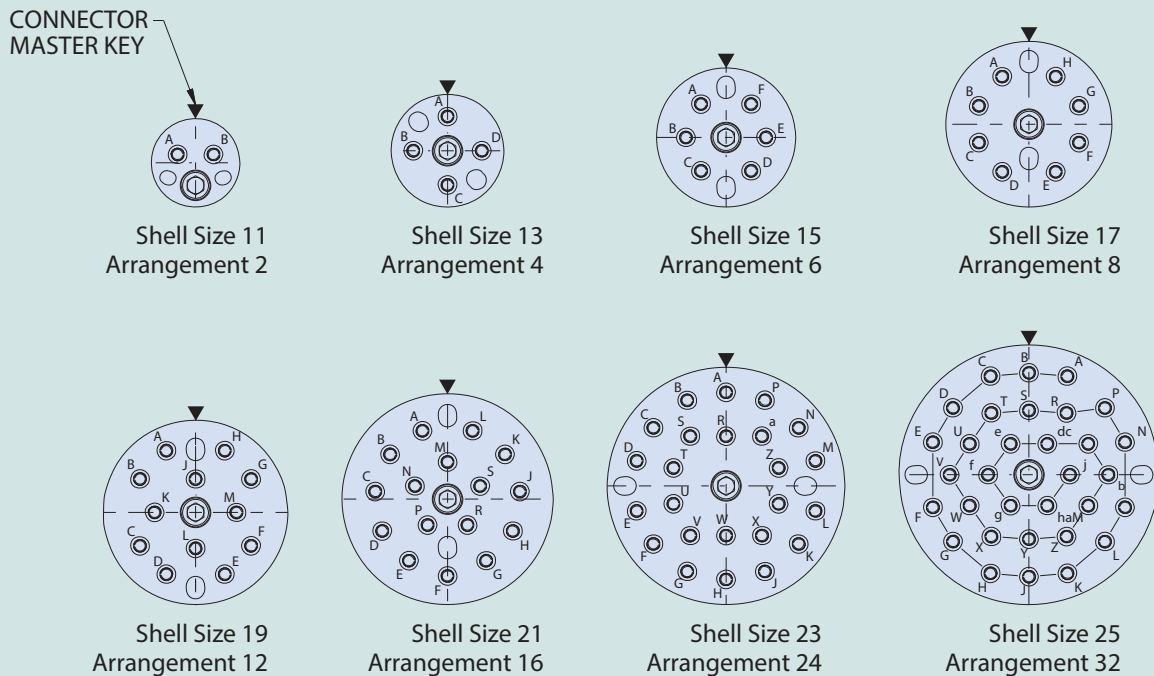

MATERIAL/FINISH:

Shells, Barrel, Coupling Nut: See Table I

Inserts: Al Alloy / Anodize

Guide Pins: Stainless Steel / Passivate

Seals: Fluorosilicone

EMI/RFI/Ground Spring (G6 configuration): Copper Alloy / Nickel

MIL-DTL-38999 SERIES III TYPE ARINC 801 Fiber Optic Connectors and Termini

How to order Termini and Plugs

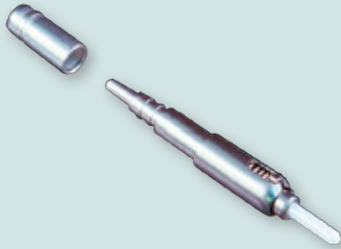

How To Order				
Sample Part Number	181-076	-	P	-126
Fiber Optic termini	Genderless terminus for ARINC 801 connector			
Cable Jacket Diameter	See Table I (previous page)			
Cable Structure	P = Pull-Proof (loose structure cable) N = Non-Pull-Proof (tight structure cable or 900 micron buffer)			
Assembly Dash Number	See Table II			

Table I: Cable Jacket Diameter	
Dash No.	Cable Jacket Diameter
A	900 micron buffer only
-	2.0/1.7mm

Table II: Ceramic Ferrule						
Dash No.	Ø A (microns)	Typ Fiber Type	Typ Fiber Size (microns) Core/Cladding	Ferrule Polish Type	L Inches	Color Band
-1255	125.5	Singlemode	9/125	PC	.196/.192	Blue
-1255A	125.5	Singlemode	9/125	APC	.200/.196	Green
-126S	126.0	Singlemode	9/125	PC	.196/.192	Blue
-126SA	126.0	Singlemode	9/125	APC	.200/.196	Green
-126	126.0	Multimode	50/125, 62.5/125	PC	.196/.192	None

NOTES

Crimp sleeve is packaged loose with terminus assembly. Spares may be ordered separately, consult factory.

Termini for 900 micron buffer are not provided with crimp sleeves

MATERIAL AND FINISH

Ferrule: Zirconia Ceramic
Terminus Bodies: Brass Alloy/Nickel
Crimp Sleeve: Brass Alloy/Nickel
Spring: Stainless Steel/Passivate



How To Order					
Sample Part Number	180-159	NF	06	-17-8	N
Fiber Optic connector	ARINC 801 connectors, MIL-DTL-38999 Series III Type				
Material/Finish Code	See Table I (previous page)				
Connector Style, Plug	06 = Plug G6 = Plug with EMI/RFI Ground Spring				
Shell Size - Insert Arrangement	See Figure I				
Alternate Key Position	per MIL-DTL-38999 Series III. A, B, C, D, E, N = Normal, omit for universal key				

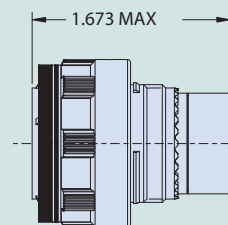
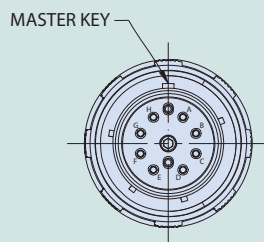

How to order Receptacles and Alignment Sleeve Retainers

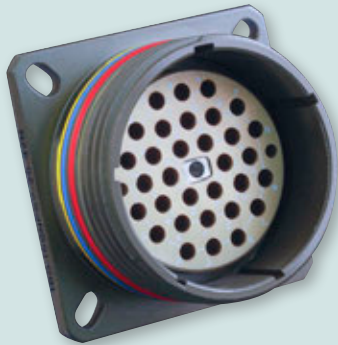

How To Order					
Sample Part Number	180-159	NF	06	-17-8	N
Fiber Optic connector	ARINC 801 connectors, MIL-DTL-38999 Series III Type				
Material/Finish Code	See Table I (previous page)				
Connector Style, Receptacle	08 = Jam Nut Receptacle 05 = In-Line Receptacle H7 = Wall Mount Receptacle with Round Holes (Standard) S7 = Wall Mount Receptacle with Slotted Holes T7 = Wall Mount Receptacle with Threaded Holes				
Shell Size - Insert Arrangement	See Figure I				
Alternate Key Position	per MIL-DTL-38999 Series III. A, B, C, D, E, N = Normal, omit for universal key				

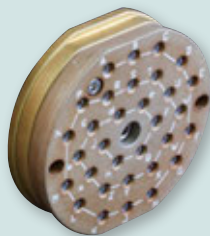
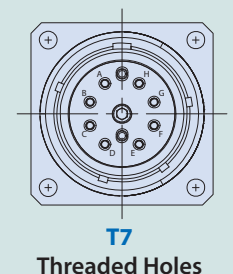
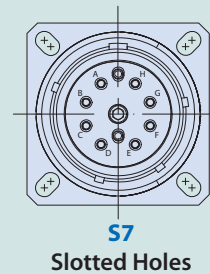
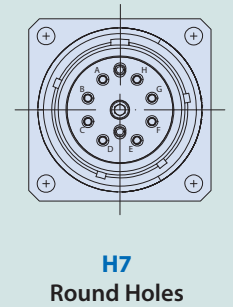
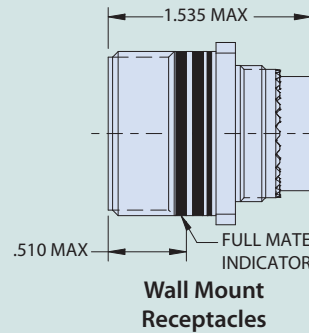
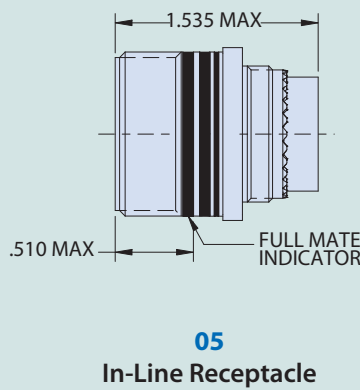
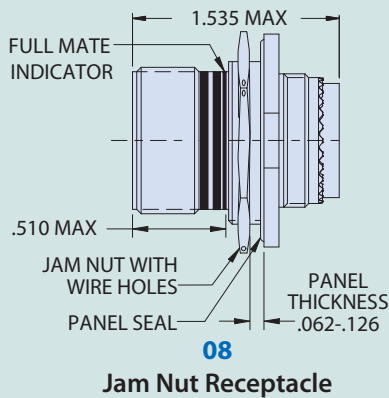

How To Order		
Sample Part Number	180-159ASR	-25-32
Fiber Optic connector	Alignment Sleeve Retainer for 180-159 plug connector	
Shell Size - Insert Arrangement	See Figure I	

NOTES

1. Housing: Al alloy/anodize
2. Misc hardware: stainless steel/passivate
3. Alignment sleeve: zirconia ceramic
4. Alignment sleeve retainer is designed to meet or exceed all mechanical and performance requirements of ARINC 801 specification.
5. Ceramic alignment sleeve replacements may be purchased separately (P/N 181-056-S)

RUGGEDIZED
PHOTONIC
INTERCONNECT
SOLUTIONS



Ruggedized High-Density, High Signal Integrity **Photonic Transceiver Modules**—up to 25Gbps Per Channel



Glenair PCB mount transceiver modules are ruggedized equivalents to SFP transceivers but with mechanical design suited to the harsh temperature and vibration environments found in free space, satellite, and other Mil-Aero applications. Optional Digital Monitoring Interface (DMI) IAW SFF 8472. High bandwidth parallel optical modules with MT datalink technology. Radiation tolerant.

- Smallest footprint available
- Jet fighter and space launch shock and vibration tested
- High-speed board interconnection — no soldering required
- CML 100 Ohm differential input and output
- -40°C to +85°C operating temperature range

RUGGEDIZED PCB-MOUNT MODULES FOR ETHERNET, HIGH-SPEED VIDEO, AND STORAGE

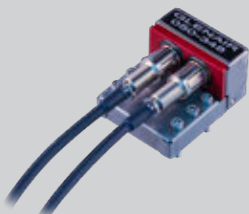

EMI shielded and radiation-tolerant transceivers



Dual transceivers, quad transmitters, quad receivers

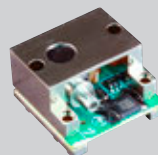

Bi-directional transceivers

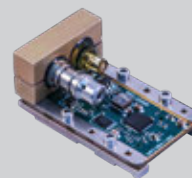

Aerospace-grade DWDM transceivers for free-space optical links

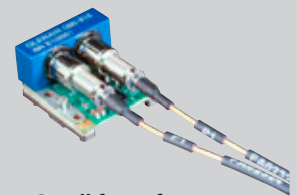

Small form-factor, high-vibration high-temperature tolerant

RUGGEDIZED

PCB-Mount Photonic Transceiver Modules



Parallel Optic Transceivers • RF-Over-Fiber Transceivers •
Bi-Directional Transceivers • Radiation-Tolerant Designs

PARALLEL OPTIC TRANSCEIVERS

Glenair parallel optic transceivers deliver up to 25Gbps per channel high-speed data in free space optics (FSO) applications. Heat tolerant and compatible with conduction cooling for space applications, the transceivers are supplied as discrete printed circuit board mount devices, or with turnkey MTP jumpers or ruggedized MT fiber optic interconnections.

- 4 X 14 to 4 X 25 Gbps per fiber (up to 100 Gbps)
- 12-channel Tx and Rx with 10Gbps/channel
- Compatible with MTP optical connector
- Supports 12-fiber ribbon cable
- SiGe and GaAs optoelectronic ICs
- Hermetic opto-electronic hybrid
- Conduction-cooling for space applications
- 46 Grms, 650G shock
- -40°C to +85°C case temp
- Heavy ion radiation-tested

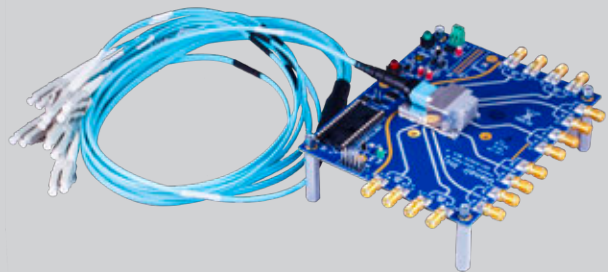
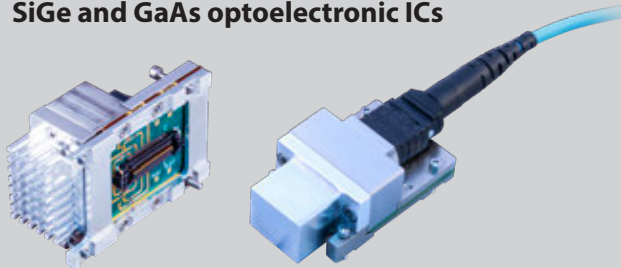

Convection cooling (left) and conduction cooling (right) designs as well as custom heat dissipation designs are available.
050-346 parallel optical transceiver, 4 X 10 – 14 Gbps
0500-3007 parallel optical transceiver, 0.1 – 25 Gbps

Available evaluation boards: 050-346 parallel optical transceiver with MT-to-39029 fiber optic terminations

RF-OVER-FIBER TRANSCEIVERS

Radio Frequency over Fiber systems integrate wireless radio frequency (RF) transmissions and fiber optic datalinks into a single system. Benefits include lower transmission loss (attenuation) as well as reduced sensitivity to electromagnetic noise. Glenair ruggedized, low-noise, shielded RF-over-Fiber solutions have a 2MHz to 3.5GHz RF bandwidth and can be embedded inside-the-box or incorporated into standalone copper-to-fiber media converters for environmental applications.

- 2MHz – 3.5 GHz antenna signal distribution
- High-frequency units in excess of 20 GHz
- High-vibration PCB mount solution
- -40°C to +85°C operating case temperature
- High Spurious Free Dynamic Range (SFDR) link
- APC fiber optic contact standard
- Integrated high-speed PIN photo diode and low-noise RF amplifiers

RF over Fiber PCB-Mount Component Selection Guide

050-400 PCB Mount RF-over-Fiber Transceiver 20MHz to 3.5 GHz	050-404 PCB Mount RF-over-Fiber Transmitter 2 MHz – 3.5 GHz	050-405 PCB Mount RF-over-Fiber Receiver 2 MHz – 3.5 GHz	050-406 PCB Mount RF-over-Fiber Transmitter 2 MHz – 3.5 GHz Low-Noise configuration	050-407 PCB Mount RF-over-Fiber Receiver 2 MHz – 3.5 GHz Low-Noise configuration

PCB-Mount Modules	Glenair Part Number	ETHERNET										VIDEO				FIBRE CHANNEL				BUS	OTHER
		100BASE-FX	100BASE-SX	100BASE-LX	100BASE-LX10	100BASE-EX	100BASE-BX10	10GBASE-SR	10GBASE-LR	10GBASE-LX4	40GBASE-SR4	100GBASE-SR4	HDMI	DVI/ARINC 818	SMPTE HD-SDI	1x Fibre Channel	2x Fibre Channel	4x Fibre Channel	8x Fibre Channel	sFPDP	
050-315		•										•	•			•	•	•		•	
050-316		•										•	•			•	•	•		•	
050-317		•										•	•			•	•	•		•	
050-318			•	•								•	•			•				•	
050-319			•	•								•	•			•	•			•	
050-320			•	•								•	•			•	•	•		•	
050-321	•																				•
050-324			•	•	•							•	•			•	•	•		•	
050-325			•	•	•							•	•			•	•	•		•	
050-327							•					•	•			•	•	•	•		
050-328								•				•	•			•	•	•	•		
050-331														•	•						
050-332														•	•						
050-333		•										•	•			•	•	•		•	
050-336		•										•	•			•	•	•		•	
050-337		•										•	•			•	•	•		•	
050-340												•	•			•					
050-341								•				•	•			•	•	•	•		
050-342			•	•								•	•			•	•				
050-343												•	•			•	•	•	•	•	
050-346							•			•						•	•	•	•		
050-348		•										•	•			•	•	•		•	
050-352	•																				•
050-354			•	•								•	•			•	•	•		•	
050-356			•	•								•	•			•	•			•	
050-357														•	•						
050-358														•							
050-360		•										•	•			•	•	•		•	
050-361		•										•	•			•	•	•		•	
050-362		•										•	•			•	•	•		•	
050-363		•										•	•			•	•	•		•	
050-364		•										•	•			•	•	•		•	
050-369							•	•				•	•			•	•	•	•		
050-373		•										•	•			•	•	•		•	
050-374		•										•	•			•	•	•		•	
050-375		•										•	•			•	•	•		•	
050-376									•			•	•			•	•	•	•	•	
050-379														•							
050-385		•										•	•			•	•	•		•	
050-386								•				•	•			•	•	•	•		
050-389														•	•						
050-394							•					•	•			•					
050-397*							•					•	•			•					
0500-3007										•		•	•			•	•	•	•		
0500-3011							•					•	•			•	•	•	•		

DESCRIPTION	DATARATE (Gbps)	WAVE LENGTH (nm)	LASER TYPE	RECEIVER TYPE	MAX. DISTANCE (km)	PACKAGE TYPE
Transceiver	0.1 - 5	850	VCSEL	PIN TIA	0.5	1
Dual Transmitter	0.1 - 5	850	VCSEL	N/A	0.5	1
Dual Receiver	0.1 - 5	850	N/A	PIN TIA	0.5	1
Transceiver	0.1 - 1.25	1310	FP	PIN TIA	10	1
Dual Transmitter	0.1 - 2.5	1310	FP	N/A	10	1
Dual Receiver	0.1 - 4.25	1310	N/A	PIN TIA	10	1
Transceiver	0.05 - 0.2	1300	LED	PIN TIA	20	1
Transceiver	0.1 - 2.5	1310	DFB	PIN TIA	40	1
Dual Transmitter	0.1 - 2.5	1310	DFB	N/A	40	1
Transceiver	1 - 10.5	850	VCSEL	PIN TIA	0.4	1
Transceiver	1 - 10.5	1310	DFB	PIN TIA	10	1
SMPTE Dual Transmitter	1.5 - 2.97	850	VCSEL	N/A	1	1
SMPTE Dual Receiver	1.5 - 2.97	850	N/A	PIN TIA	1	1
Dual Transceiver	0.1 - 5	850	VCSEL	PIN TIA	0.5	2
Quad Transmitter	0.1 - 5	850	VCSEL	N/A	0.5	2
Quad Receiver	0.1 - 5	850	N/A	PIN TIA	0.5	2
BIDI Transceiver	0.1 - 1.25	1310/1550	FP/FP	PIN TIA	4	1
BIDI Transceiver	1 - 10	1270/1330	DFB/DFB	PIN TIA	10	1
CWDM Transceiver	0.1 - 2.5	CWDM	DFB	PIN TIA	20	1
CWDM Transceiver	1 - 10.5	CWDM	DFB	PIN TIA	10	1
Parallel Optical Transceiver	4 X 10 - 14	850	VCSEL	PIN TIA	0.5	3
EMI Shielded Transceiver	0.1 - 5	850	VCSEL	PIN TIA	0.5	1
Transceiver	0.05 - 0.2	1310	FP	PIN TIA	10	1
Transceiver	2.5 - 5	1310	FP	PIN TIA	10	1
CWDM Dual Transmitter	0.1 - 2.5	CWDM	DFB	N/A	10	1
SMPTE Dual Receiver	1.5 - 2.97	1250-1600	VCSEL	PIN TIA	10	1
SMPTE CWDM Dual Transmitter	1.5	CWDM	DFB	N/A	10	1
Radiation-Tolerant Dual Transmitter	0.1 - 5	850	VCSEL	N/A	0.5	1
Radiation-Tolerant Dual Receiver	0.1 - 5	850	VCSEL	PIN TIA	0.5	1
Radiation-Tolerant Transceiver	0.1 - 5	850	VCSEL	PIN TIA	0.5	1
Radiation-Tolerant Quad Transmitter	0.1 - 5	850	VCSEL	N/A	0.5	2
Radiation-Tolerant Quad Receiver	0.1 - 5	850	VCSEL	PIN TIA	0.5	2
Transceiver MMF TX · SMF RX	1 - 10	850 TX 1310 RX	VCSEL	PIN TIA	10	1
Dual-Transceiver (4 mounting screws)	0.1 - 5	850	VCSEL	PIN TIA	0.5	2
Quad Transmitter (4 mounting screws)	0.1 - 5	850	VCSEL	N/A	0.5	2
Quad Receiver (4 mounting screws)	0.1 - 5	850	N/A	PIN TIA	0.5	2
CWDM Dual Transmitter	1 - 10	CWDM	DFB	N/A	10	1
SMPTE CWDM Transceiver	1.5	CWDM	DFB	PIN TIA	10	1
Radiation-Tolerant Dual Transceiver	0.1 - 5	850	VCSEL	PIN TIA	0.5	2
Dual Transmitter	1 - 10.5	850	VCSEL	PIN TIA	0.4	1
SMPTE Transceiver	1.5 - 2.97	850	VCSEL	PIN TIA	1	1
BIDI Transceiver	0.1 - 2.5	1310/1490	DFB/DFB	PIN TIA	10	1
BIDI Transceiver	0.1 - 1.25	1310/1550	DFB/DFB	PIN TIA	10	1
Parallel Optical Transceiver	4 X 25	850	VCSEL	PIN TIA	0.1	3
DWDM EML FSO Transceiver	11.3	DWDM	EML	PIN TIA	40	1



Ruggedized **Size #8** **Photonic Transmitter and** **Receiver Contacts and** Connectors for Ethernet, Video and High-Speed Data



Size 8 photonic contacts transmit and receive differential CML or LVPECL electrical signals over Multimode fiber optic cable. Transmitters consist of a 850nm VCSEL laser with temperature compensation circuit. Receivers consist of a PIN Photo Detector, a Transimpedance Amplifier with automatic gain control circuit, and a Limiting Amplifier.

Differential output data signals are LVPECL or CML compatible.



Patented photonic contacts integrate into Glenair circular and rectangular connectors including SuperNine® (D38999 Series III), ARINC 801, ARINC 404, and others.

- Fast and Gigabit Ethernet, DVI, HDMI video capable transmitter and receiver-equipped contacts
- ARINC 664, 801, 803, 804 and 818 standard compliant
- Link distances up to 550 meters, multimode
- Single, 3.3 V power supply
- For use in ARINC 600 and other size #8 cavity-equipped connectors
- Current offerings include 1.25mm ARINC 801 and 2.5mm ELIO® solutions

RUGGEDIZED

Photonic Contacts and Connectors for Ethernet, Video and High-Speed Data



050-301 SIZE 8 CAVITY OPTO-ELECTRONIC CONTACTS, 100MBPS TO 5GBPS, MMF, 3.3V

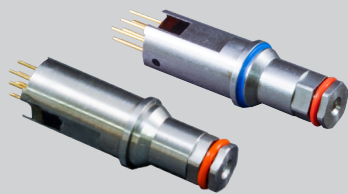

050-301
Radiation Tolerant

- Front-release, front-insert, front-removable Size #8 OE converter designed for ARINC 600
- ARINC 664, 801, 803, 804, and 818 Standard Compliant
- Data rates from 100Mbps to 5.00Gbps
- Supports Fast and Gigabit Ethernet, AFDX, 1x/2x Fibre Channel, DVI, DHMI, SFPDP, Serial Rapid I/O (sRIO)
- 100 ohms differential CML inputs with Tx Fault and Tx Disable
- Link distances up to 550 meters with multimode 50/125µm or 62.5/125 µm fiber
- Single 3.3V power supply
- ARINC 801 1.25mm ceramic fiber ferrule
- Solutions available in 38999 style connectors
- -40°C to +85°C Operating Case Temperature
- Evaluation fixtures available

050-307 SIZE 8 CAVITY OPTO-ELECTRONIC CONTACTS, 100MBPS TO 5GBPS, MMF, 3.3V



050-307
Radiation Tolerant

- Front-release, front-insert, front-removable Size #8 OE converter designed for ARINC 600
- ARINC 664, 801, 803, 804, and 818 Standard Compliant
- Data rates from 100Mbps to 5 Gbps
- Supports Fast and Gigabit Ethernet, AFDX, 1x/2x Fibre Channel, DVI, DHMI, SFPDP, Serial Rapid I/O (sRIO)
- 100 ohms differential CML inputs with Tx Fault and Tx Disable
- Link distances up to 550 meters with multimode 50/125µm or 62.5/125 µm fiber
- Single 3.3V power supply
- ELIO 2.5mm ceramic fiber ferrule
- Solutions available in 38999 style connectors
- Mates with ELIO 2.5mm Termini
- -40°C to +85°C Operating Case Temperature
- Evaluation fixtures available
- Compatible with Souriau ELIO AQ6S Quadrax Adapter

050-367 SIZE 8 CAVITY OPTO-ELECTRONIC CONTACTS, 3G-SDI AND HD-SDI, MMF, 3.3V



050-367
(patented)

- SMPTE EG 34:2004 Compliant to Pathological Conditions CASE 1, CASE 2 and CASE 3.
- SMPTE ST 297:2015 (3G-SDI & HD-SDI)
- SMPTE 424 Compliant (3G-SDI)
- SMPTE 292 Compliant (HD-SDI)
- SFP Compatible Electrical Input signal levels
- 850nm VCSEL support 3G-SDI & HD-SDI
- Industry standard CML input and outputs that make for simple integration on customer host PCB
- Front-release, front-insert, front-removable
- Fits size 8 quadrax cavity for ARINC 600
- Solutions available in 38999 style connectors
- -40°C to +85°C Operating Case Temperature
- Evaluation fixtures available

050-399 SIZE 8 CAVITY OPTO-ELECTRONIC CONTACTS, DC TO 10 MBPS, MMF, 3.3V



050-399
(patented)

- Front-release, front-insert, front-removable Size #8 OE converter designed for ARINC 600
- ARINC 664, 801, 803, 804, and 818 Standard Compliant
- Data rates from DC to 1 Mbps
- Supports RS232, RS422, and RS485 data rates
- DC coupled transmitter and receiver
- Link distances up to 2Km
- Single 3.3V power supply
- ARINC 801 1.25mm ceramic fiber ferrule
- Solutions available in 38999 style connectors
- -40°C to +85°C Operating Case Temperature
- Evaluation fixtures available

RUGGEDIZED
PHOTONIC
INTERCONNECT
SOLUTIONS



Small Form-Factor, Harsh-Environment **Photonic Contacts and Connectors** for Box I/O Fiber-to-Copper Media Conversion



Special size #8 cavity adapters facilitate construction of standard fiber optic plug connectors that intermate with size #8 optoelectronic transceiver contacts



Glenair size #8 optoelectronic contacts are easily housed in a range of circular and rectangular connectors for fast/gigabit Ethernet, DVI and HDMI video, and other high-speed data transfer protocols. Special size #8 cavity adapters are available to enable construction of compatible plug connectors on the cable side.

- 2.5mm ELIO® solution for multimode Ethernet, video, and high-speed data applications
- 1.25mm ARINC 801 multimode fiber optic termini solution for Ethernet, video, and high-speed data
- Hybrid high-speed layouts with Size #8 Optoelectronic contacts and Glenair Signature El Ochito high-speed Octaxial contacts











Glenair SuperNine D38999 Series III type optoelectronic connectors populated with size #8 contacts, ready for immediate assembly in cable or I/O to circuit board applications

ELIO® is a registered trademark of SOURIAU

RUGGEDIZED

Photonic Contacts and Connectors for Ethernet, Video and High-Speed Data



Optoelectronic Connector Selection Guide		
	050-313	Optoelectronic Transceiver, MIL-DTL-38999 Type 2.5mm ELIO® Compatible 100Mbps – 4.25Gbps
	050-304	D38999 Series III Type Active Receptacle Connector with Glenair Size 8 Optoelectronic Contacts 050-304 CS Wall Mount, Clinch Nut 050-304 00 Wall Mount, Slotted 050-304 07 Jam Nut 059-0001 - D38999 Size 8 Cavity Adapter Kit (Includes ARINC 801 Style Terminus)
	050-392	D38999 Series III Type Active Hybrid Receptacle Connector with Glenair Size 8 Optoelectronic and Electrical Contacts 050-392 07 Jam Nut 059-0001 - D38999 Size 8 Cavity Adapter Kit (Includes ARINC 801 Style Terminus)
	050-355	D38999 Series III Type Active Receptacle Connector with Glenair Size 8 Optoelectronic Contacts. 050-355 CS Wall Mount, Clinch Nut 050-355 00 Wall Mount, Slotted 050-355 07 Jam Nut 059-0001 - D38999 Size 8 Cavity Adapter Kit (Includes ARINC 801 Style Terminus)
	0500-3004	D38999 Series III Type Active Hybrid Receptacle Connector with PCB standoffs, Glenair Size 8 Optoelectronic contacts, and electrical contacts Compatible with 050-301 and 050-367 contacts 059-0001 - D38999 Size 8 Cavity Adapter Kit (Includes ARINC 801 Style Terminus)
	0500-3005	D38999 Series III Type Active Hybrid Receptacle Connector with Glenair Size 8 Optoelectronic Contacts, and El Ochito Contacts. 0500-3005 CS Wall Mount, Clinch Nut 0500-3005 00 Wall Mount, Slotted 0500-3005 07 Jam Nut
	0500-3001	D-Sub Active Receptacle Connector with Glenair Size 8 Optoelectronics Contacts. Compatible 050-301, 050-367, 050-399, and 0500-3015 contacts 1.25 Gbps – 5.00 Gbps / HD-SDI and 3G-SDI / DC to 50 Mbps
	0500-3024	D-Sub Active Receptacle Connector with 2 × Glenair Size 8 Optoelectronics Contacts. Compatible 050-301 and 050-367 contacts 1.25 Gbps – 5.00 Gbps
	0500-3034	D-Sub Active Receptacle Connector with 2 × Glenair Size #8 Optoelectronics Contacts. Compatible 050-301, 050-367, 050-399, and 0500-3015 contacts 1.25 Gbps – 5.00 Gbps / HD-SDI and 3G-SDI / DC to 50 Mbps

RUGGEDIZED
PHOTONIC
INTERCONNECT
SOLUTIONS



Small Form-Factor, Harsh-Environment Copper-To-Fiber **Media Converters** for Ethernet Applications



Glenair offers small form-factor harsh-environment media converters for in-line and select panel mount applications, for conversion of 10/100/1000BASE-SX/LX fiber optic gigabit Ethernet data streams to electrical signals servicing switches, routers, and other peripherals. 1.25mm, 1.58mm, 2.0mm, and 2.5mm ferrule single- and multimode fiber formats supported for virtually every fiber-optic-to-copper application requirement.

- Reduced form-factor devices for in-line conversion of electrical and optical signals
- Active cable versions that reduce the risk of damage to fiber optic interfaces
- Weight-saving technology that incorporates power and signal conversion functions
- Advanced monitor and control functions via serial interface to facilitate network management / BIT

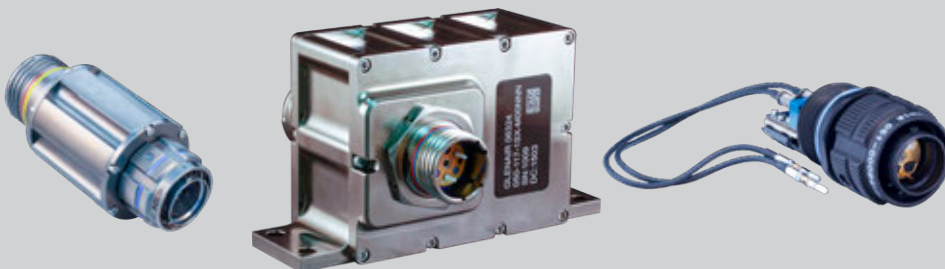

RUGGEDIZED Copper-to-Fiber Media Converters for Ethernet Applications

Block diagram and features



EXAMPLE FUNCTIONAL BLOCK DIAGRAM FOR GLENAIR 050-105 ETHERNET MEDIA CONVERTER

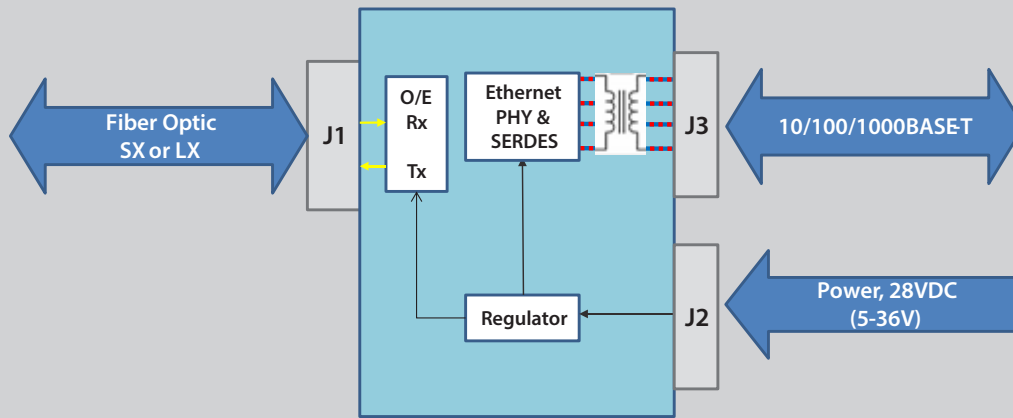
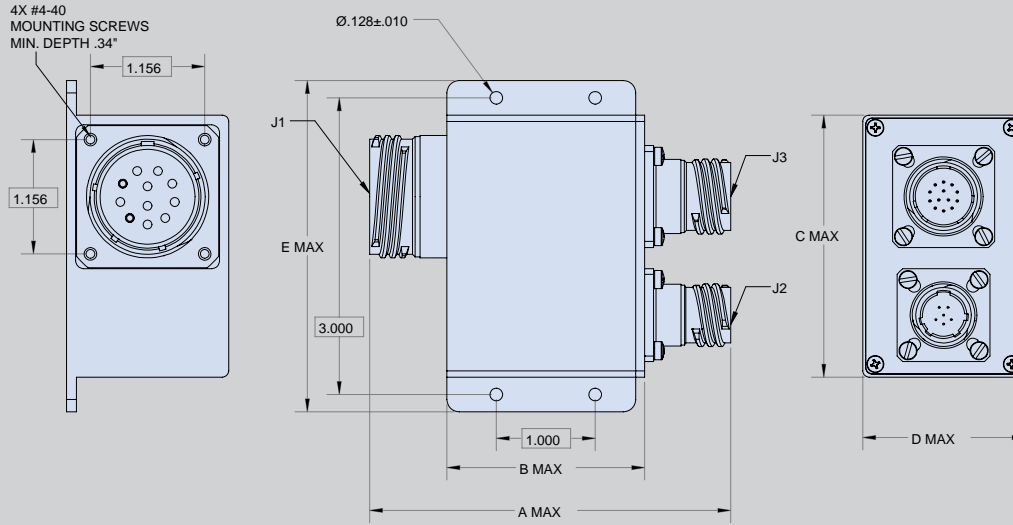

DATA CABLES • POWER CABLES • TEST CABLES

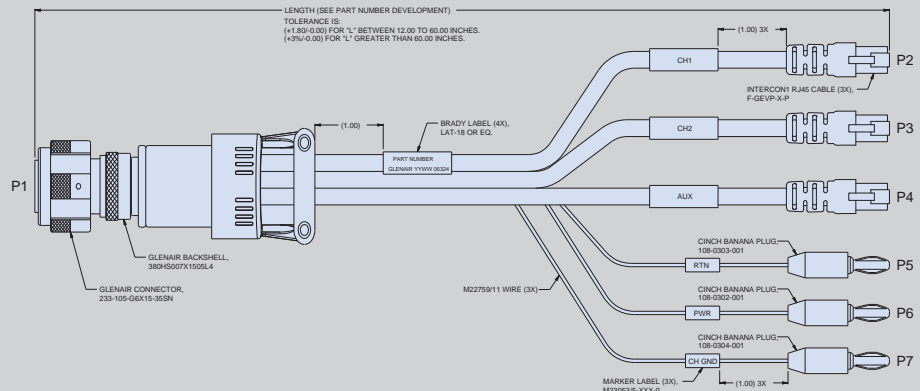
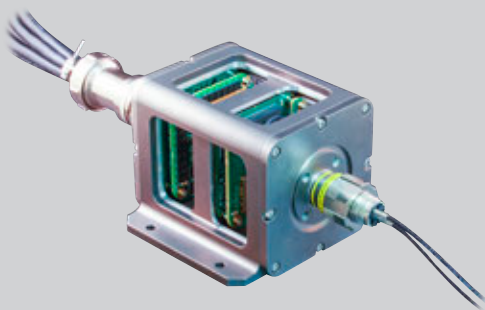

Data cables, power cables, and fiber optic test cables with EMI/RFI banding and strain relief backshells are available for all Ethernet copper-to-fiber media converters

RUGGEDIZED

Copper-to-Fiber Media Converters for Ethernet Applications

Product Selection Guide

	050-101	Gigabit Ethernet Copper to Fiber Media Converter 1000BASE-T to 1000BASE-SX/LX MIL-DTL-38999 Series III signal, power, and fiber optic interfaces
	050-103	10/100/1000BASE-T to 1000BASE-SX In-Line Media Converter with MIL-DTL-38999 Series III power, signal, and fiber optic interfaces
	050-105	Copper to Fiber Ethernet Media Converter 10/100/1000BASE-T to Fiber Optic Ethernet (SX, LX10, EX, FX) MIL-DTL-38999 Series III signal, power, and fiber optic interfaces
	050-110	Media Converter, Single Channel 1000BASE-T to 1000BASE-LX10, 18-36VDC, SMF, GFOCA (FO), M38999 (Signal), M38999 (Power)
	050-111	Media Converter, Dual Channel 10/100/1000BASE-T to Fiber Optics GFOCA (FO), M38999 (Signal), M38999 (Power)
	050-112	Media Converter, Dual or Single Channel, Panel Mount 10/100/1000BASE-T to Fiber Optic Ethernet (1000BASE-SX/LX10 or 100BASE-FX), 28VDC, M38999 (Signal and Power), GFOCA (Fiber Optic)
	050-113	Media Converter, Dual or Single Channel, Panel Mount 10/100/1000BASE-T to Fiber Optic Ethernet (1000BASE-SX, 1000 BASE-LX10 or 100BASE-FX), 28VDC, M38999 (Signal and Power), M38999 (Fiber Optic)
	050-131	Media Converter, Dual or Single Channel, Panel Mount 10/100/1000BASE-T to Fiber Optic Ethernet 18 to 36VDC, M38999 (Signal and Power), M83526 (Fiber Optic)
	050-115	Media Converter, Dual or Single Channel, Panel Mount 10/100/1000BASE-T to CWDM Fiber Optic Ethernet 18 to 36VDC, M38999 (Signal and Power), M38999 (Fiber Optic)

RUGGEDIZED

Copper-to-Fiber Media Converters for Ethernet Applications



Product Selection Guide



050-117

Line Replaceable Unit (LRU) Copper to Fiber Media Converter, Single or Dual Channel, Flange Mount

10/100/1000BASE-T to Fiber Optic Ethernet
(1000BASE-SX, 1000 BASE-LX10 or 100BASE-FX) 28VDC (DO-160 Audio Conducted Susceptibility Cat Z), Lightning Strike (DO-160 level 3 waveform 3/3)
M38999 (ARINC801), M38999 (Quadrax), M38999 (Power)



050-130

Line Replaceable Unit (LRU) Copper to Fiber Media Converter, Single or Dual Channel, Flange Mount. All connectors on the same side.

10/100/1000BASE-T to Fiber Optic Ethernet
(1000BASE-SX, 1000 BASE-LX10 or 100BASE-FX) 28VDC (DO-160 Audio Conducted Susceptibility Cat Z), Lightning Strike (DO-160 level 3 waveform 3/3) M38999 (ARINC801), M38999 (Quadrax), M38999 (Power)



050-123

Copper to Fiber Single Channel Ethernet Media Converter

10/100/1000BASE-T to Single Fiber 1310/1550 Bidirectional Optical Ethernet
28VDC
M38999 (Signal), M38999 (Power), M38999 (Fiber Optic)



050-129

Line Replaceable Unit (LRU) Copper to Fiber Media Converter Assembly

10/100/1000BASE-T to 100BASE-FX or 1000BASE-SX/LX/EX, 28VDC or USB 5V Bus Power
Mighty Mouse connectors for Signal, Power, and fiber



050-134

Dual or Single Channel, Panel Mount 10/100/1000BASE-T to Fiber Optic Ethernet

(1000BASE-SX, 1000 BASE-LX10 or 100BASE-FX), 28VDC
M38999 (Signal and Power), M28876 (Fiber Optic)



050-137

Single Channel, Panel Mount 10/100/1000BASE-T to Fiber Optic Ethernet

(1000BASE-SX, 1000 BASE-LX10 or 100BASE-FX), 28VDC
Might Mouse Series 801 (Signal and Power), Pro Beam Mini (Fiber Optic)



050-138

Dual or Single Channel, Panel Mount 10/100/1000BASE-T to Fiber Optic Ethernet

(1000BASE-SX, 1000 BASE-LX10 or 100BASE-FX), 28VDC
M38999 (Signal and Power), GHD (Fiber Optic)



050-139

Single or Dual Channel Ethernet + 2 Channels of RS232

(1000BASE-SX, 1000 BASE-LX10 or 100BASE-FX)
28VDC (DO-160 Audio Conducted Susceptibility Cat Z),
Lightning Strike (DO-160 level 3 waveform 3/3)
M38999 (ARINC801), M38999 (Quadrax), M38999 (Power), M38999 (RS232)



050-143

Line Replaceable Unit (LRU) Copper to Fiber Media Converter, Single or Dual Channel, Flange Mount

10/100/1000BASE-T to Fiber Optic Ethernet
(1000BASE-SX, 1000 BASE-LX10 or 100BASE-FX) 28VDC (DO-160 Audio Conducted Susceptibility Cat Z), Lightning Strike (DO-160 level 3 waveform 3/3)
M38999 (Fiber Optic), M38999 (Quadrax), M38999 (Power)

RUGGEDIZED
PHOTONIC
INTERCONNECT
SOLUTIONS



Small Form Factor Media Converters for Harsh-Environment Video Applications



Glenair Copper-to-Fiber-Optic Video Media Converters enable extended link distances, improved EMI and security in harsh environments for both multi- and singlemode fiber applications including DVI, HDMI, SMPTE (SDI, HD-SDI and 3G-SDI), ARINC 818 and more. Units are available with a wide range of Glenair and industry-standard electrical and fiber optic connectors.



- Fiber link up to 500m multimode, 10km singlemode
- Standard 1560 and custom contact arrangements—including quadrax and coaxial
- Power supply functions with wide input-voltage ranges
- DVI, HDMI, SMPTE, ARINC 818
- Advanced monitor and control functions via serial interface to facilitate network management / BIT

RUGGEDIZED

Copper-to-Fiber Media Converters for Video Applications



Block diagram and features

VIDEO MEDIA CONVERTER FUNCTIONAL BLOCK DIAGRAM

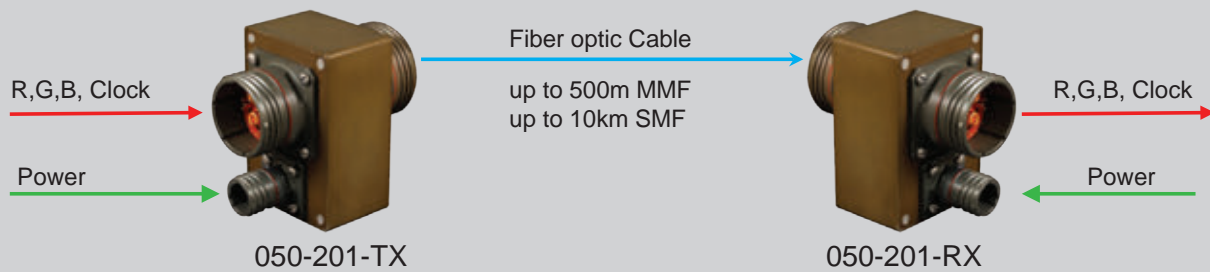
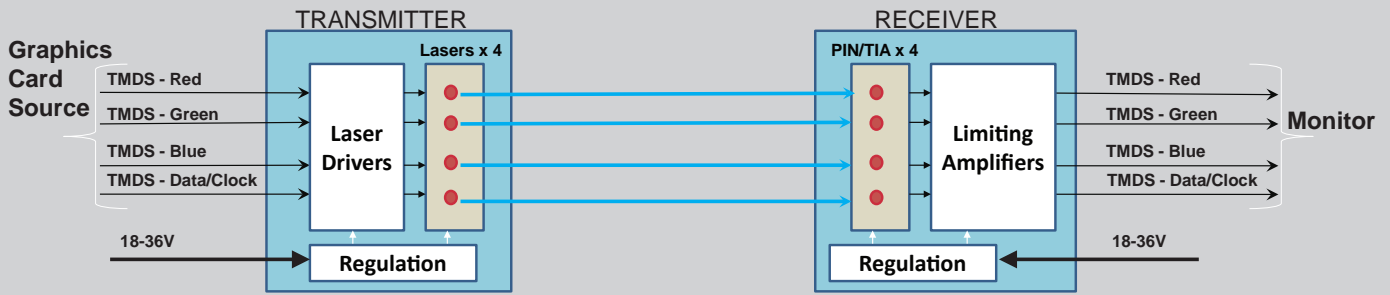

DATA CABLES • POWER CABLES • TEST CABLES

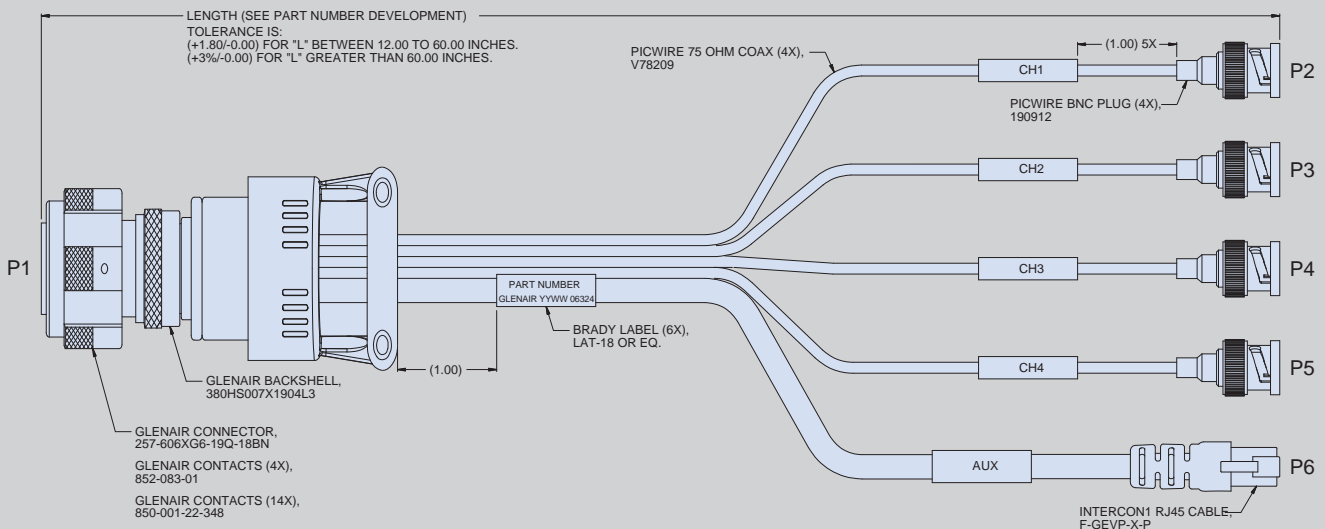

Data cables, power cables, and fiber optic test cables with EMI/RFI banding and strain relief backshells are available for all Video copper-to-fiber media converters

RUGGEDIZED

Copper-to-Fiber Media Converters for Video Applications

Product Selection Guide



050-201

DVI Copper to Fiber Media Converter
with MIL-DTL-38999 power, signal, and fiber optic connectors



050-203

DVI Extender - Copper to Fiber Media Converter
with MIL-DTL-38999 power, signal, and fiber optic connectors



050-205

Copper to Fiber DVI Media Converter, 28VDC
D38999 (ARINC801 for Fiber Optic), D38999 (Quadrax & Pin contacts for Signal, Power and Service Port)



050-206

Dual-DVI Copper to Fiber Media Converter,
28VDC
D38999 (ARINC801 for Fiber Optic),
D38999 (Quadrax & Pin contacts for Signal and Service Port),
D38999 (Pin contacts for Power)



050-207

4-Channel SMPTE Copper to Fiber Media Converter
HD-SDI and 3G-SDI with MIL-DTL-38999 and Glenair High Density (GHD)
power, signal, and fiber optic connectors

RUGGEDIZED

Copper-to-Fiber Media Converters for Video Applications

Product Selection Guide

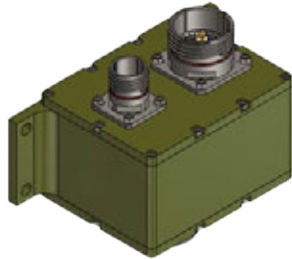

050-208

**4-Channel SMPTE HD-SDI Copper to Fiber Media Converter
(DO-160 Lightning Strike, DO-160 Audio Conducted Susceptibility Cat Z)**
D38999 (ARINC801 for Fiber Optic),
D38999 (100 ohms Quadrax & Pin contacts for Signal and Service Port),
D38999 (Pin contacts for Power) connectors



020-210

Dual DVI Copper to Fiber Media Converter, 28VDC
D38999 (Eye-Beam for Fiber Optic)
D38999 (Quadrax & Pin contacts for Signal, Service Port)
D38999 (Pin contacts for Power) connectors



050-211

**CWDM 4-Channel SMPTE Copper to Fiber Media Converter,
SMF or MMF, 28VDC**
GHD Glenair High Density (GHD for Fiber Optic)
D38999 (75 Ohms Quadrax & Pin contacts for Signal, Service Port)



050-214

**DVI Copper to Fiber Media Converter,
28VDC**
D38999 (ARINC801 for Fiber Optic),
D38999 (Quadrax & Pin contacts for Signal and Service Port),
D38999 (Pin contacts for Power)

RUGGEDIZED
PHOTONIC
INTERCONNECT
SOLUTIONS



Ruggedized Aggregated Signal Copper-to-Fiber Media Converters

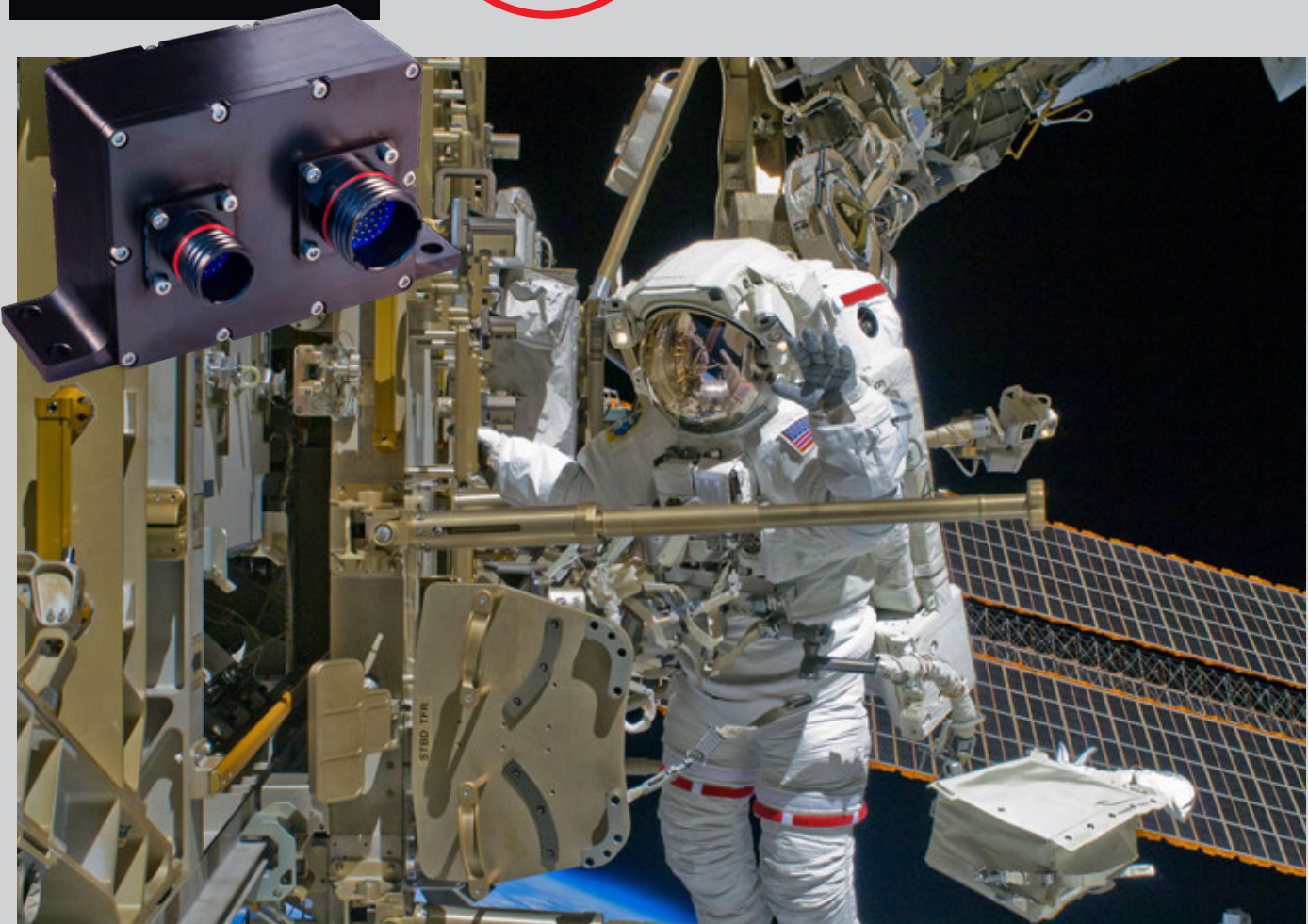

Glenair signal aggregation media converters integrate a set of compact optoelectronic modules to digitize and/or aggregate multiple common signal types, and combine them onto high-data-rate serial optical fiber channels.

- One high-speed opto-electronic interface can serve practically all signal types
- Ideal solution to enable optical rotary joints
- -40°C to +85°C operating temperature range
- Meets MIL-STD-810 Mechanical Shock and Vibration
- Meets MIL-STD-1344 immersion resistance
- Advanced monitor and control functions via serial interface to facilitate network management / BIT

Featured Signal Aggregation Media Converter



050-513

Copper to Fiber Aggregation Media Converter

4 Channel RS422/RS485 + 2 Discrete Signals, with MIL-DTL-38999 Series III power, signal, and fiber optic connectors.

Block diagram and features

SIGNAL AGGREGATOR FUNCTIONAL DIAGRAMS

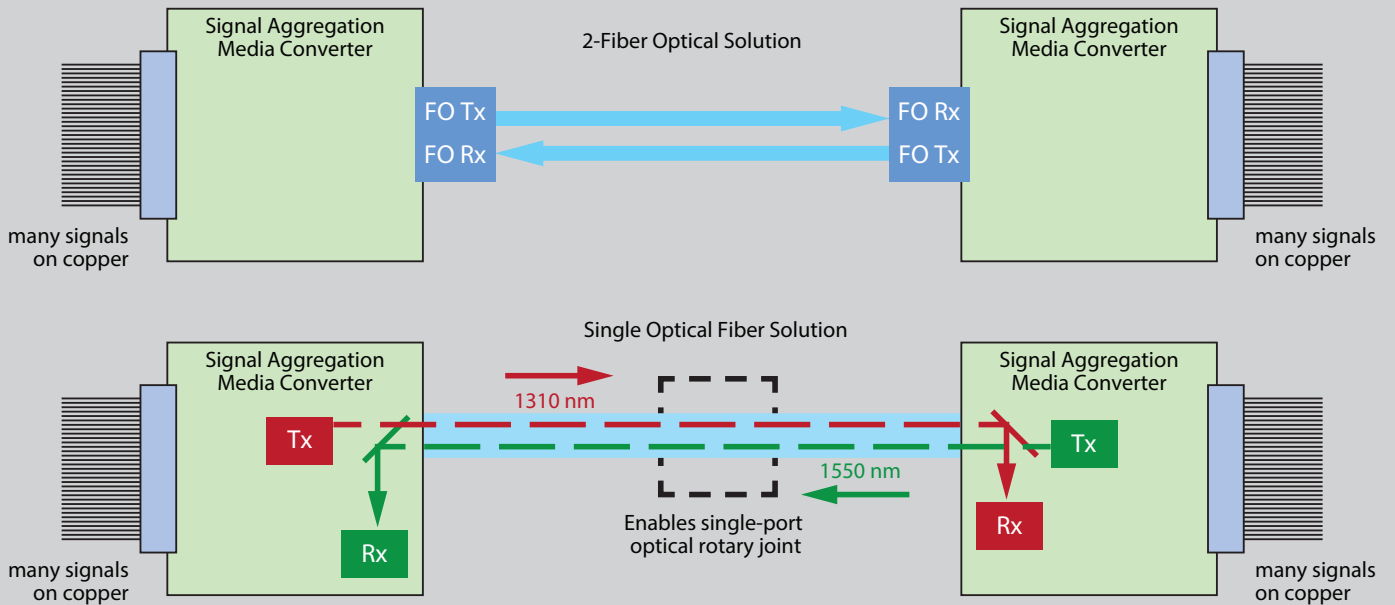
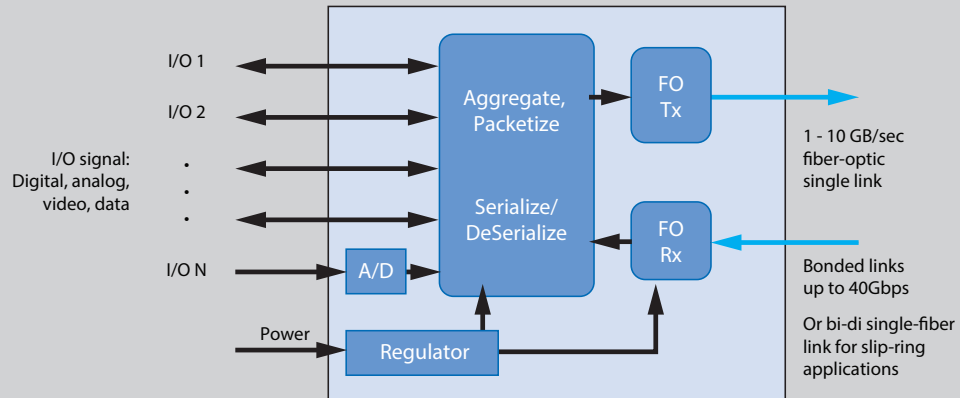

MOTHERBOARD AND DAUGHTER CARD ARCHITECTURE FOR BROAD SIGNAL COMPATIBILITY

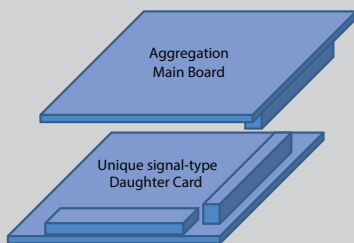

SERIAL

- RS422/RS485
- RS232
- USB
- MIL-STD-1553
- CAN Bus
- ARINC 429
- SMBus
- I2C
- SPI
- Ethernet 10/100/1000

VIDEO

- DVI
- HDMI
- SMPTE SDI
- SMPTE HD-SDI
- SMPTE 3G-SDI
- ARINC 818
- VGA

ANALOG

- RF/IF Sampling
- Analog Sensor Data

Contact the factory for other signal formats and custom configurations

RUGGEDIZED
PHOTONIC
INTERCONNECT
SOLUTIONS



Small Form-Factor Electrical and Hybrid Opto-Electrical **Ethernet Switches**



Glenair unmanaged harsh-environment Ethernet switches are layer 2 switches with Auto negotiation and Auto MDI / MDIX circuitry that enables port expansion with IEEE-802.3U 10/100/1000Base-T Ethernet ports.

Electronics are incorporated into a ruggedized panel-mountable housing sealed against liquid and solid contaminants.

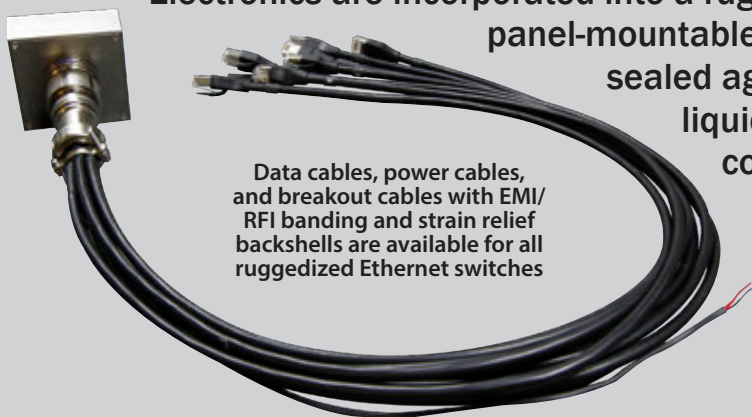

Data cables, power cables, and breakout cables with EMI/RFI banding and strain relief backshells are available for all ruggedized Ethernet switches

- Unmanaged—plug and play operation—no configuration required
- Jumbo frame support in all speeds (10/100/1000 Mbps)
- Operating temperature range: -40°C to +85°C
- Standard ultraminiature Mighty Mouse electrical and M28876 type fiber optic connector interfaces
- Breakout cables with industry-standard connector interfaces available

Small Form-Factor Electrical and Hybrid Opto-Electrical Ethernet Switches



Block diagram and product selection guide

ETHERNET SWITCH EXAMPLE BLOCK DIAGRAM

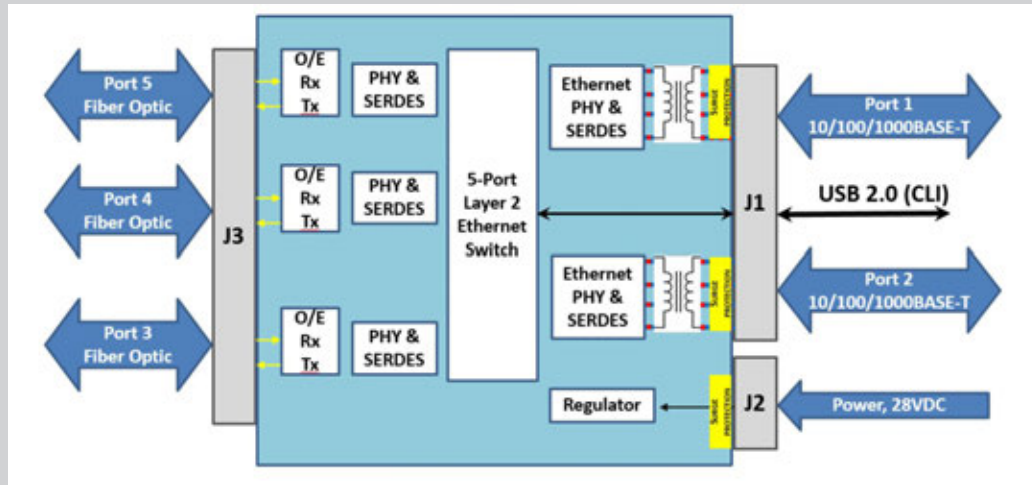

050-124

5-Port Smart Ethernet Switch (Customer Configurable via USB 2.0)

2 Electrical Ports & 3 Fiber optic Ports
 10/100/1000BASE-T, 1000BASE-SX, 1000BASE-LX, 100BASE-FX
 28VDC (DO-160 Audio Conducted Susceptibility Cat Z), Lightning Strike (DO-160 level 3 waveform 3/3)

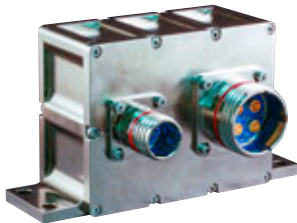

050-128

6-Port Smart Ethernet Switch (Customer Configurable via USB 2.0 Command Line Interface)

4 Electrical Ports: 10/100BASE-T & 2 Fiber optic Ports (customer selectable): 100BASE-FX, 1000BASE-SX, 1000BASE-LX 28VDC (DO-160 Audio Conducted Susceptibility Cat Z), Lightning Strike (DO-160 level 3 waveform 3/3)



050-119

4-Port Ethernet Switch: 2 Electrical Ports & 2 Fiber optic Ports

Panel Mount, 10/100/1000BASE-T, 1000BASE-SX/LS/FX



052-101

7-Port Unmanaged Ethernet Switch 10/100/1000 BASE-T

With Series 805 Mighty Mouse Connector

COMPLEMENTARY
HIGH-SPEED
ELECTRICAL
INTERCONNECTS

E1 Ochito®

High-Speed **Octaxial Contacts** For Ethernet,
SuperSpeed USB and Multi-Gigabit Datalinks

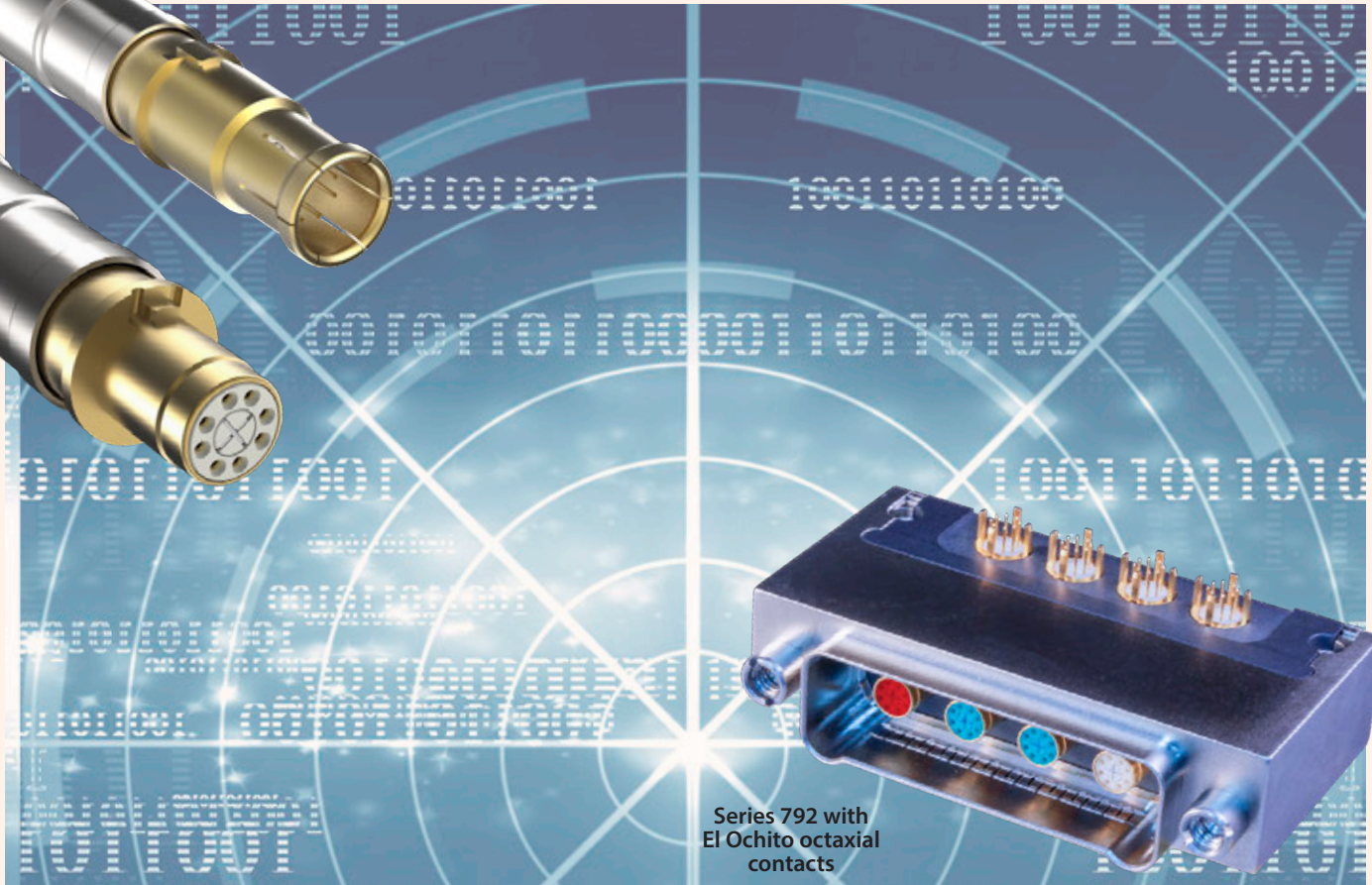

Series 792 with
E1 Ochito octaxial
contacts

High speed, harsh environment E1 Ochito® octaxial contacts save size and weight in aircraft avionics, weapons systems, satellites, radars, and communications equipment.

AVAILABLE SIGNATURE CONNECTOR PACKAGING INCLUDES



SuperFly
Nanominiature

806 Mil-Aero
Micro miniature

SuperNine
"Better than QPL" 38999

- 10GbE, SuperSpeed USB, and multi-gigabit shielded pairs
- Universal drop-in for keyed size #8 connector cavities
- Data-pair isolation for optimal signal integrity
- Crimp or threaded shield termination contact types
- Snap-in, rear release
- Environmentally sealed
- Aerospace-grade cable assemblies
- 50% cable / contact reduction compared to Quadrax

HIGH-SPEED OCTAXIAL El Ochito® Contacts



Protocols, exploded views of Type I and Type II contacts

El Ochito® White



1000BASE-T, 10GBASE-T

El Ochito® White octaxial contacts provide 10GbE in a single size #8 contact cavity (compared to two Quadrax) for 100BASE-T solutions.

El Ochito® Blue



SuperSpeed USB

Low-dielectric material. 90 ohms. El Ochito® Blue octaxial contacts provide an aerospace-grade solution for SuperSpeed USB 3.0

El Ochito® Red



HDMI, DisplayPort, SATA

Low-dielectric material. Up to 5 Gbps. 100 ohms. El Ochito® Red octaxial contacts provide an aerospace-grade solution for multi-gigabit data rates.

El Ochito® Type I Contacts, Non-Serviceable

26 AWG, Crimp Wire Shield Termination

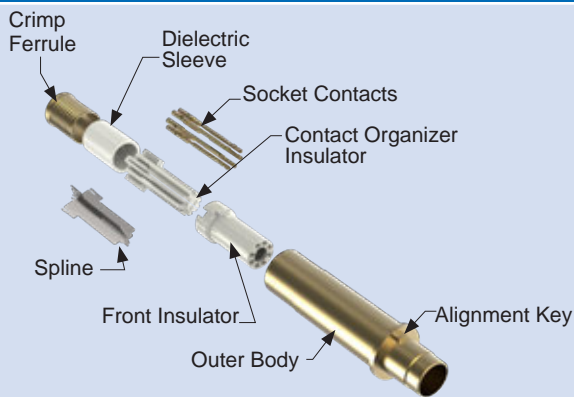

Type I Pin Contact

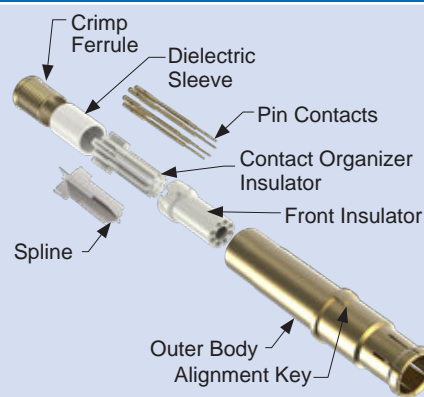

Type I Socket Contact

El Ochito® Type II Contacts, Serviceable

24-26 AWG, Threaded Wire Shield Termination, Integral Contact Release Sleeve

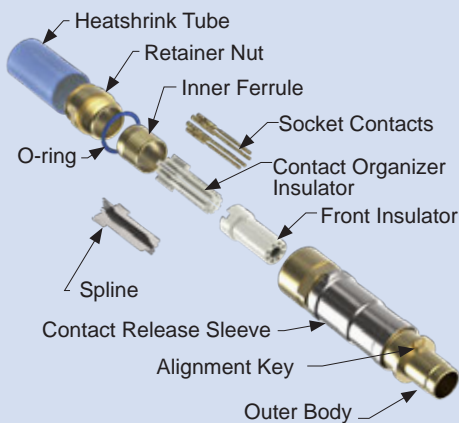

Type II Pin Contact

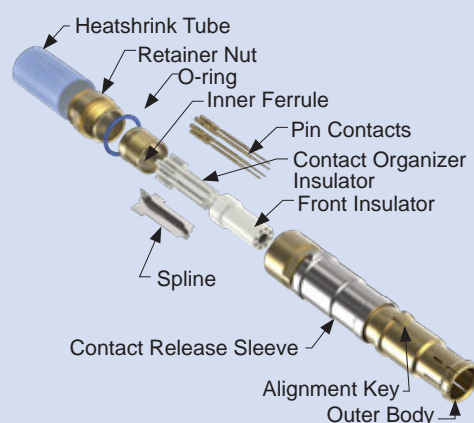

Type II Socket Contact

HIGH-SPEED OCTAXIAL El Ochito® White Contacts



How To Order

El Ochito® Contacts: How To Order								
					Data Protocol: 10G Ethernet El Ochito® White			
Connector Type	Wire Size	Cable Type	Cable		El Ochito® Type I		El Ochito® Type II	
			Glenair Part No. <i>(Mfr. P/N)</i>	Cable Dia.	Pin Contact <i>Assembly Instr.</i>	Sket Contact <i>Assembly Instr.</i>	Pin Contact <i>Assembly Instr.</i>	Sket Contact <i>Assembly Instr.</i>
ARINC 600	26	S/UTP	963-003-26 (PIC E6A3826)	.220 (5.56)	858-009-01 AI85074-01	858-010-01 AI85074-01		
		S/FTP	963-033-26 (Gore RCN9047-26)	.220 (5.56)	858-009-02 AI85084-01	858-010-02 AI85084-01		
Series 23 SuperNine®	24	S/UTP	963-037-24	.260 (6.60)			858-005-03 AI85097-03	858-006-03 AI85097-03
		S/FTP	963-033-24	.260 (6.60)			858-005-04 AI85097-04	858-006-04 AI85097-04
Series 801 and 805 Mighty Mouse	26	S/UTP	963-003-26 (PIC E6A3826)	.220 (5.56)	858-003-01F AI85048-01	858-004-01F AI85048-01	858-005-01 AI85097-01	858-006-01 AI85097-01
		S/FTP	963-033-26 (Gore RCN9047-26)	.220 (5.56)	858-003-02F AI85048-02	858-004-02F AI85048-02	858-005-02 AI85097-01	858-006-02 AI85097-01
Series 792	24		963-037-24 (PIC E6A3824)	.260 (6.60)			858-043-03 AI85134-03	858-042-03 AI85134-03
			963-033-24 (Gore RCN9047-24)	.260 (6.60)			858-043-04 AI85134-04	858-042-04 AI85134-04
	26	S/UTP	963-003-26 (PIC E6A3826)	.220 (5.56)	858-045-01F AI85048-01	858-046-01F AI85048-01	858-043-01 AI85134-01	858-042-01 AI85134-01
		S/FTP	963-033-26 (Gore RCN9047-26)	.220 (5.56)	858-045-02F AI85048-02	858-046-02F AI85048-02	858-043-02 AI85134-02	858-042-02 AI85134-02
Series 806	24	S/UTP	963-037-24 (PIC E6A3824)	.260 (6.60)			858-051-03 AI85149-03	858-052-03 AI85149-03
		S/FTP	963-033-24 (Gore RCN9047-24)	.260 (6.60)			858-051-04 AI85149-04	858-052-04 AI85149-04
	26	S/UTP	963-003-26 (PIC E6A3826)	.220 (5.56)	858-045-01F AI85048-01	858-046-01F AI85048-01	858-051-01 AI85149-01	858-052-01 AI85149-01
		S/FTP	963-033-26 (Gore RCN9047-26)	.220 (5.56)	858-045-02F AI85048-02	858-046-02F AI85048-02	858-051-02 AI85149-02	858-052-02 AI85149-02
EPXB	26	S/UTP	963-003-26 (PIC E6A3826)	.220 (5.56)	858-014-02F AI85099-01	858-015-02F AI85099-01		
		S/FTP	963-033-26 (Gore RCN9047-26)	.220 (5.56)	858-014-01F AI85105-01	858-015-01F AI85105-01		

HIGH-SPEED OCTAXIAL El Ochito® Blue and Red Contacts



How To Order

El Ochito® Contacts: How To Order



Data Protocol: SuperSpeed USB El Ochito® Blue

Connector Type	Wire Size	Cable Type	Cable		El Ochito® Type I	
			Glenair Part No.	Cable Dia.	Pin Contact Assembly Instr.	Socket Contact Assembly Instr.
Series 792 and 806	26	Commercial Grade (PVC Jacket)	963-118	.217 (5.51)	858-047-01F A185114-02	858-048-01F A185114-02
		Aerospace Grade (Fluoropolymer Jacket)	963-110	.236 (5.99)	858-047-02F A185090-01	858-048-02F A185090-01
Series 23 SuperNine® Series 801 and 805 Mighty Mouse Series 28 HiPer-D®	26	Commercial Grade (PVC Jacket)	963-118	.217 (5.51)	858-028-01F A185114-02	858-029-01F A185114-02
		Aerospace Grade (Fluoropolymer Jacket)	963-110	.236 (5.99)	858-028-02F A185090-01	858-029-02F A185090-01
ARINC 600	26	Commercial Grade (PVC Jacket)	963-118	.217 (5.51)	858-038-01 A185124-01	858-035-01 A1852124-01
		Aerospace Grade (Fluoropolymer Jacket)	963-110	.236 (5.99)	858-038-02 A185124-02	858-035-02 A185124-02



Data Protocol: HDMI/SATA/DisplayPort/General High-Speed El Ochito® Red

Connector Type	Wire Size	Cable Type	Cable		El Ochito® Type I	
			Glenair Part No.	Cable Dia.	Pin Contact Assembly Instr.	Socket Contact Assembly Instr.
Series 792 and 806	26	4 Pair S/FTP	1Gb/s and above 963-122-X*	.299 (7.59)	858-049-01F* A185048-02	858-050-01F* A185048-02
Series 23 SuperNine® Series 801 and 805 Mighty Mouse Series 28 HiPer-D®			Up to 1Gb/s 963-033-26	.220 (5.56)	858-030-02F* A185048-02	858-031-02F* A185048-02
ARINC 600			HDMI/Display Port 963-120-X* 963-127-X*	.429 (10.9) .330 (8.38)	858-039-01 A185084-01	858-037-01 A185084-01
Series 792 and 806	26	Parallel Pair Twinax	SATA 963-043-26 [2 pcs.]	.116 x .071 (2.95 x 1.80)	858-049-02 A185084-02	858-050-02 A185084-02
Series 23 SuperNine® Series 801 and 805 Mighty Mouse Series 28 HiPer-D®					858-030-03 A185084-03	858-031-03 A185084-03
ARINC 600					858-039-02 A185084-02	858-037-02 A185084-02

* Omit F when using this cable

COMPLEMENTARY
HIGH-SPEED
ELECTRICAL
INTERCONNECTS



The Next-Generation **Micro Miniature Rectangular Connector** With **EI Ochito** Contacts For High-Speed Aerospace Applications



The Series 792 connector brings high-speed data-rate performance to the Glenair Series 79 rectangular family. Size 8 cavities accept standard Quadrax or EI Ochito® shielded octaxial contacts making it a perfect choice for radars, weapons systems, mission computers and displays, communications gear, and more.



EI Ochito®

- High-speed Ethernet, USB 3.0, HDMI, and DisplayPort
- PCB-mount and cable connectors
- Scoop-proof interface
- 12 arrangements and 6 shell sizes
- Precision-machined dual-lobe polarized shells
- Environmentally sealed
- Integrated EMI shielding and grounding
- Blind mating

HIGH-SPEED Series 792



The next-generation micro miniature rectangular for high-speed aerospace applications

DESCRIPTION	REQUIREMENT	PROCEDURE / NOTES
Operating temperature	-65° to +175°C	EIA-364-32 Test Condition IV
Current rating	1.5 Amps (datalink contacts) 5 Amps (Size #23 contacts)	Datalink contacts tested: El Ochito® White
DWV (sea level)	750 VAC (Size #23 contacts) 1000 VAC (datalink contacts)	EIA-364-20
Insulation resistance	5000 MΩ minimum	EIA-364-21
Contact resistance, 25°C	55 millivolt maximum	EIA-364-06, 1.0 A test current, #24 AWG wire

DESCRIPTION	REQUIREMENT	PROCEDURE / NOTES	
Shell-to-shell resistance	2.5 millivolt maximum	EIA-364-83	
Shielding effectiveness	Frequency	Attenuation dB	EIA-364-66
	100	75	
	1000	50	
	3000	44	
	6000	38	
10000	35		
Ingress protection	IP67 rating	IEC-60529	

Insert Arrangements



A-1W1 • A-1G1*
1 #8

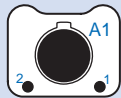

A-3W1
1 #8 / 2 #23

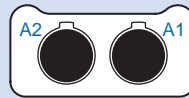

B-2W2 • B-2G2*
2 #8

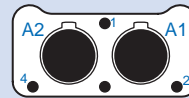

B-6W2
2 #8 / 4 #23

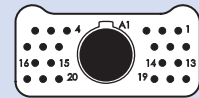

B-23W1
1 #8 / 22 #23

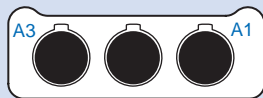

C-3W3 • C-3G3*
3 #8

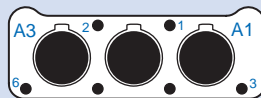

C-9W3
3 #8 / 6 #23

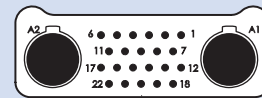

C-24W2
2 #8 / 22 #23

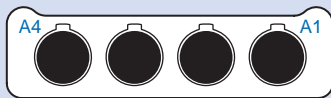

D-4W4 • D-4G4*
4 #8

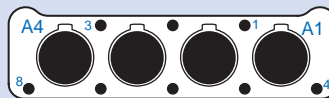

D-12W4
4 #8 / 8 #23

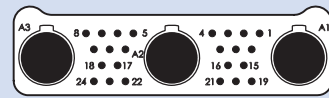

D-27W3
3 #8 / 24 #23

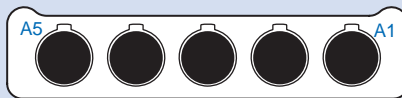

E-5W5 • E-5G5*
5 #8

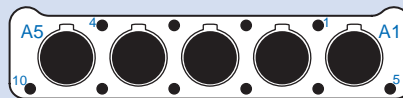

E-15W5
5 #8 / 10 #23

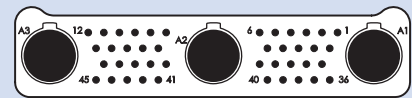

E-48W3
3 #8 / 45 #23

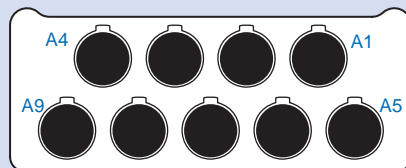

F-9W9 • F-9G9*
9 #8

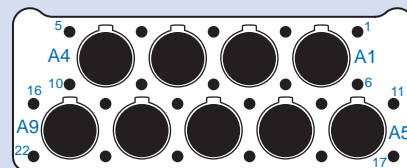

F-31W9
9 #8 / 22 #23

Contact Key

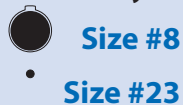

* Grounded aluminum insert

HIGH-SPEED Series 792

The next-generation micro miniature rectangular for high-speed / high-data rate aerospace applications



Save Size and Weight with Series 792 Connectors

The Multi-Port Multi-Protocol Connector with El Ochito® Contacts

About The Series 792

The Series 792 brings high-speed board-to-wire capability to the Glenair Series 79 family of ultraminiature rectangular connectors. The Series 792 is intended for avionics and aerospace equipment exposed to high-vibration and hostile environments.

The 792 supports quadrax contacts for ARINC 664 and El Ochito® octaxial contacts for 10Gb Ethernet, USB 3.0, HDMI and other protocols.

Machined aluminum alloy shells feature dual lobes for polarization. Pin contacts are recessed to prevent scooping damage. Crimp contacts conform to M39029 requirements and are rear release.

An optional ground spring in the receptacle minimizes EMI. Fluorosilicone face seals and wire grommets protect from moisture and contamination. Panel mount versions are available with an O-ring—or for improved panel bonding—a metal spring.

Board mount versions include straight or right angle terminals. Right angle PCB connectors feature an aluminum cover for added EMI protection.

Metal EMI Panel Spring

A gold-plated panel spring option is available for Series 792 connectors with panel mount flanges. This spring provides improved electrical bonding.



Twinax, Quadrax and El Ochito® Connectors are available in three configurations: twinax for a single high-speed wire pair, quadrax for two data pairs, and El Ochito® for four data pairs.

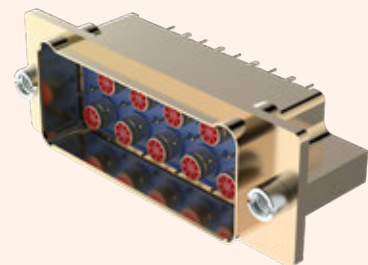

Up to 9 data ports

The Series 792 Size F with nine ports is the largest connector in the series and is the only two row version. Sizes A – E, with one to five ports, are single row.

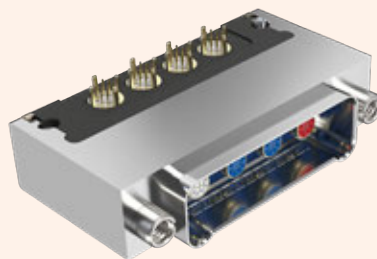

PCB Connectors

Series 792 PCB connectors have straight or right angle PC tails. Contacts are non-removable and are epoxy sealed. Right-angle connectors eliminate the need for board-to-panel I/O jumpers.



Panel Mount

Panel mount connectors have an O-ring and threaded mounting holes for easy installation. Suitable for blind mate modules, the Series 792 is available with guide pins and float mounts.



El Ochito® White	El Ochito® Blue	El Ochito® Red
GbE 10GbE	USB 3.0	HDMI, SATA, DisplayPort

El Ochito® Contacts

Series 792 connectors feature El Ochito® octaxial contacts for Ethernet, SuperSpeed USB, HDMI, DisplayPort, SATA and other multi-gigabit protocols. Multiple protocols can be supported in a single multi-port connector.



Cable Connectors

Quadrax and El Ochito® contacts snap into Series 792 cable connectors and are easily removed with a standard plastic tool. Alignment keys provide correct orientation.

HIGH-SPEED Series 792



The next-generation micro miniature rectangular for high-speed / high-data rate aerospace applications

Cable Connectors Snap-in crimp contacts		Panel Mount Connectors Snap-in crimp contacts		Float Mount Connectors Snap-in crimp contacts	
Plug	Receptacle	Plug	Receptacle	Plug	Receptacle
792-001	792-002	792-003	792-004	792-013	792-014

EI Ochito® Printed Circuit Board Connectors with Octaxial Contacts Epoxy-sealed non-removable PCB terminals							
Straight PCB		Panel Mt Straight PCB		90° PCB		Panel Mount 90° PCB	
Plug	Receptacle	Plug	Receptacle	Plug	Receptacle	Plug	Receptacle
792-005	792-006	792-007	792-008	792-009	792-010	792-011	792-012

Quadrax Printed Circuit Board Connectors Epoxy-sealed non-removable PCB terminals							
Straight PCB		Panel Mt Straight PCB		90° PCB		Panel Mount 90° PCB	
Plug	Receptacle	Plug	Receptacle	Plug	Receptacle	Plug	Receptacle
792-018	792-019	792-020	792-021	792-022	792-023	792-024	792-025

Series 792 High-speed Ultraminiature Rectangular Connectors with EI Ochito® Octaxial Contacts

			<ul style="list-style-type: none"> ■ 10GbE, SuperSpeed USB, and multi-gigabit shielded pairs ■ Crimp shield termination and threaded contact types ■ Snap-in, rear release ■ Environmentally protected ■ Aerospace-grade performance
EI Ochito® White GbE 10GbE	EI Ochito® Blue USB 3.0	EI Ochito® Red HDMI, SATA, DisplayPort	

RECOMMENDED BACKSHELL

799-164
Split EMI Banding Backshell

COMPLEMENTARY
HIGH-SPEED
ELECTRICAL
INTERCONNECTS

SERIES
806
MIL-AERO

806 Mil-Aero: Advanced
Performance, Reduced
Size and Weight
Connector Series IAW
MIL-DTL-38999



Series 806 meets key performance benchmarks for harsh vibration, shock, and environmental settings—as well as high-altitude, unpressurized aircraft zones with aggressive voltage ratings and altitude immersion standards.



Series 806 with four 10GbE El Ochito channels

El Ochito®

- Next-generation micro miniature aerospace-grade circular connector
- Upgraded environmental, electrical and mechanical performance IAW MIL-DTL-38999 Series III
- Integrated anti-decoupling technology
- High-Speed El Ochito® and hybrid #22HD contact arrangements

SERIES 806 MIL-AERO CONNECTORS WITH EL OCHITO® CONTACTS



White
GbE
10GbE



Blue
USB 3.0



Red
HDMI, SATA,
DisplayPort

- 10GbE, SuperSpeed USB 3.0, HDMI and DisplayPort
- Crimp shield termination and threaded contact types
- Snap-in, rear release
- Environmentally protected

HIGH-SPEED Series 806 Mil-Aero Micro Miniature Circular Connectors with El Ochito® octaxial contacts



Series 806 with El Ochito® contact arrangements

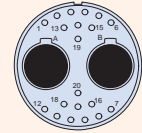
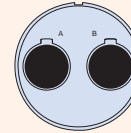
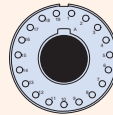
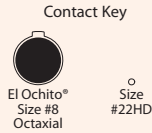

Insert Arrangement
No. of Contacts

10-1
1x #8

14-20A
1x #8 | 19x #22HD

16-2
2x #8

16-22
2x #8 | 20x #22HD

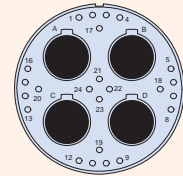
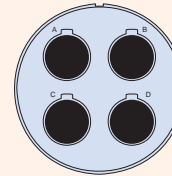
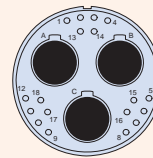
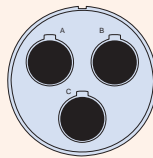
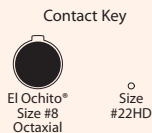

Insert Arrangement
No. of Contacts

18-3
3x #8

18-21
3x #8 | 18x #22HD

20-4
4x #8

20-28
4x #8 | 24x #22HD

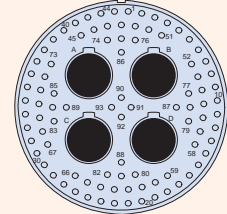
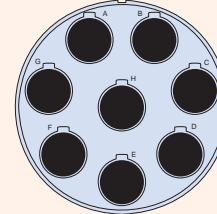
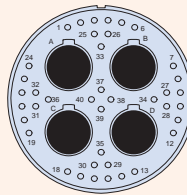
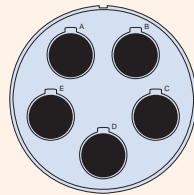
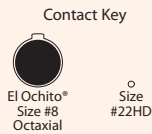

Insert Arrangement
No. of Contacts

22-5
5x #8

22-44
4x #8 | 40x #22HD

24-8
8x #8

24-97
4x #8 | 93x #22HD

Polarizing Positions

Position	A°	B°	C°	D°
A	105	140	215	265
B	102	170	248	305
C	80	150	230	295
D	68	140	205	275
E	64	155	234	304
F	72	120	200	298

FEATURES

- Triple-start stub ACME mating thread
- El Ochito® Octaxial and hybrid High density #22HD arrangements for reduced size / weight and high-speed performance
- Aerospace-grade materials, construction, and performance

CONNECTOR CONSTRUCTION

- Shell and coupling nut: aluminum or stainless steel
- Contacts: copper alloy, gold plating
- Wire grommet: fluorosilicone
- Dielectric inserts: high grade rigid dielectric
- Peripheral seal: fluorosilicone
- Ground spring: copper alloy, nickel plating
- Contact retention clips: copper alloy
- Ratchet springs: stainless steel, passivated
- Retainer rings: stainless steel, passivated
- Clinch nuts: stainless steel, passivated

RECOMMENDED BACKSHELL

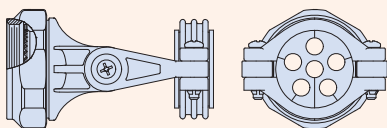

627-259

Swing-Arm 3-in-1 strain relief
with cable bushing (consult factory)

HIGH-SPEED Series 806 Mil-Aero Micro Miniature Circular Connectors with El Ochito® octaxial contacts

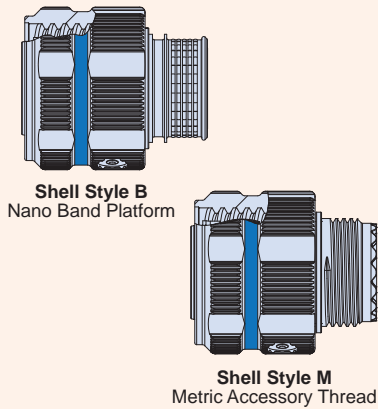

How To Order Series 806 El Ochito® Plugs						
SAMPLE PART NUMBER	806-012	-ME	18-3	S	M	A
Product	806-012 = Cable Plug					
Shell Material and Finish	ME = Aluminum, Electroless Nickel MT = Aluminum, Ni/PTFE ZR = Aluminum, Black Zinc-Nickel NF = Aluminum, Olive Drab Cadmium Z1 = Stainless Steel, Passivated					
Arrangement Number (Shell Size - Insert Arr.)	See Contact Arrangements Table					
Contact Type	P = Pin S = Socket					
Shell Style	M = Metric accessory threads B = Nano Band platform					
Polarizing Position	A B C D E F					

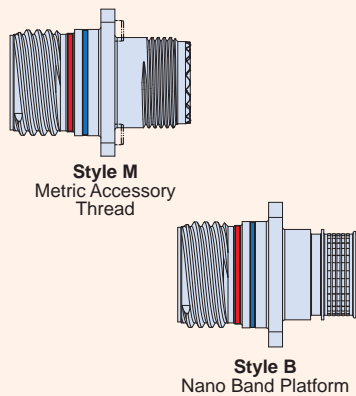

How To Order Series 806 El Ochito® Square Flange Receptacles							
SAMPLE PART NUMBER	806-013	-MT	18-21	P	B	C	A
Product	806-013 = Panel Receptacle, Square Flange, Crimp						
Shell Material and Finish	ME = Aluminum, Electroless Nickel MT = Aluminum, Ni/PTFE ZR = Aluminum, Black Zinc-Nickel NF = Aluminum, Olive Drab Cadmium Z1 = Stainless Steel, Passivated						
Arrangement Number (Shell Size - Insert Arr.)	See Contact Arrangements Table						
Contact Type	P = Pin S = Socket						
Shell Style	M = Metric accessory threads B = Nano Band platform						
Mounting Hole Style	T = Thru holes C = Clinch nut, #4-40 (rear panel mounting)						
Polarizing Position	A B C D E F						

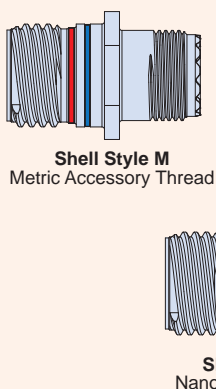

How To Order Series 806 El Ochito® In-Line Receptacles						
SAMPLE PART NUMBER	806-019	-MT	18-21	P	B	A
Product	806-019 = In-Line Receptacle					
Shell Material and Finish	ME = Aluminum, Electroless Nickel MT = Aluminum, Ni/PTFE ZR = Aluminum, Black Zinc-Nickel NF = Aluminum, Olive Drab Cadmium Z1 = Stainless Steel, Passivated					
Arrangement Number (Shell Size - Insert Arr.)	See Contact Arrangements Table					
Contact Type	P = Pin S = Socket					
Shell Style	M = Metric accessory threads B = Nano Band platform					
Polarizing Position	A B C D E F					

HIGH-SPEED Series 806 Mil-Aero Micro Miniature Circular Connectors with El Ochito® octaxial contacts

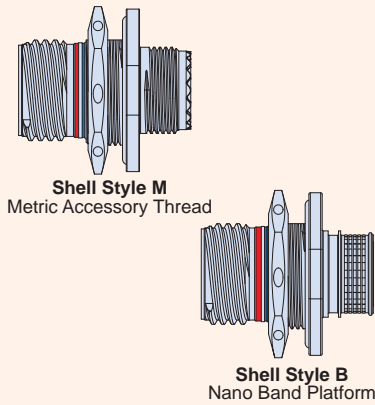

How To Order Series 806 El Ochito® Jam Nut Receptacles						
SAMPLE PART NUMBER	806-020	-MT	18-21	P	B	A
Product	806-020 = Jam Nut Receptacle					
Shell Material and Finish	ME = Aluminum, Electroless Nickel MT = Aluminum, Ni/PTFE ZR = Aluminum, Black Zinc-Nickel NF = Aluminum, Olive Drab Cadmium Z1 = Stainless Steel, Passivated					
Arrangement Number (Shell Size - Insert Arr.)	See Contact Arrangements Table					
Contact Type	P = Pin S = Socket					
Shell Style	M = Metric accessory threads B = Nano Band platform					
Polarizing Position	A B C D E F					

Table VI - Ochito Contact Positions

B = Blue, R = Red, W = White

SYM	El Ochito Contact Designator							
	A	B	C	D	E	F	G	H
E	W	W	W	W	W	W	W	W
E2	B	W	W	W	W	W	W	W
E3	R	W	W	W	W	W	W	W
E4	B	B	W	W	W	W	W	W
E5	R	B	W	W	W	W	W	W
E6	R	R	W	W	W	W	W	W
E7	B	B	B	W	W	W	W	W
E8	R	B	B	W	W	W	W	W
E9	R	R	B	W	W	W	W	W
E10	R	R	R	W	W	W	W	W
E11	B	B	B	B	W	W	W	W
E12	R	B	B	B	W	W	W	W
E13	R	R	B	B	W	W	W	W
E14	R	R	R	B	W	W	W	W
E15	R	R	R	R	W	W	W	W
E16	B	B	B	B	B	W	W	W
E17	R	B	B	B	B	W	W	W
E18	R	R	B	B	B	W	W	W
E19	R	R	R	B	B	W	W	W
E20	R	R	R	R	B	W	W	W
E21	R	R	R	R	R	W	W	W
E22	B	B	B	B	B	B	W	W
E23	R	B	B	B	B	B	W	W
E24	R	R	B	B	B	B	W	W
E25	R	R	R	B	B	B	W	W
E26	R	R	R	R	B	B	W	W
E27	R	R	R	R	R	B	W	W
E28	R	R	R	R	R	R	W	W
E29	B	B	B	B	B	B	B	W
E30	R	B	B	B	B	B	B	W
E31	R	R	B	B	B	B	B	W
E32	R	R	R	B	B	B	B	W
E33	R	R	R	R	B	B	B	W
E34	R	R	R	R	R	B	B	W
E35	R	R	R	R	R	R	B	W
E36	R	R	R	R	R	R	R	W
E37	B	B	B	B	B	B	B	B
E38	R	B	B	B	B	B	B	B
E39	R	R	B	B	B	B	B	B
E40	R	R	R	B	B	B	B	B
E41	R	R	R	R	B	B	B	B
E42	R	R	R	R	R	B	B	B
E43	R	R	R	R	R	R	B	B
E44	R	R	R	R	R	R	R	B
E45	R	R	R	R	R	R	R	R

How To Order Series 806 El Ochito® PCB Receptacles								
SAMPLE PART NUMBER	806-039	-MT	14	E	-	18-21	P	A
Product	806-039 = Jam Nut 806-040 = Square-Flange							
Shell Material and Finish	ME = Aluminum, Electroless Nickel MT = Aluminum, Ni/PTFE ZR = Aluminum, Black Zinc-Nickel NF = Aluminum, Olive Drab Cadmium Z1 = Stainless Steel, Passivated							
Shell Size	10, 14, 16, 18, 20, 22, 24							
Contact Type	See Table VI							
Ground Option	G = Common Ground - = None							
Contact Arrangement Number	See Contact Arrangements Table							
Contact Gender	P = Pin S = Socket							
Panel Mount Thru-Hole Style	(for 806-040 square-flange only) T = Thru-Hole C = Clinch Nuts for Rear Panel Mount Omit for 806-039 Jam Nut							
Polarizing Position	A B C D E F							

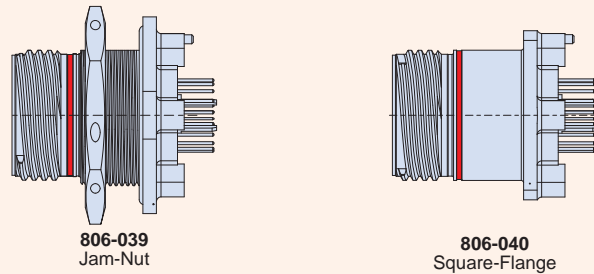

COMPLEMENTARY
HIGH-SPEED
ELECTRICAL
INTERCONNECTS



High-Speed Micro-D:
Smallest and Lightest
Aerospace-Grade
High-Speed Connector
Solution



The High-Speed Micro-D is a 1 Amp pre-wired cable and PCB solution with 10+ Gb/sec. performance per differential pair. Auxiliary EMC ground springs on plug and integral contact separation architecture ensures data integrity and low attenuation performance.

- Pre-wired factory cordsets and PCB connectors
- Unique contact isolation and spacing for optimal high-speed performance
- Standard layouts support maximum #28 AWG wire
- Ultra-low dielectric material combined with optimized contact size and spacing
- Precision-machined shells with gold or nickel plating
- Hybrid contact solutions available with 3 amp and 1 amp TwistPin contacts (perfect for USB 3.0 SuperSpeed applications)

High-Speed Micro-D connectors and cables are optimized for high-speed digital datalink protocols with machined-shell packaging, low attenuation contact spacing, and ultra low PPS dielectric insulators.



HIGH-SPEED Micro-D



The miniature high-speed connector with mil-spec pedigree connector and contact packaging

SUPPORTED HIGH-SPEED PROTOCOLS

Shell Sizes and contact arrangements optimized for today's popular high-speed protocols

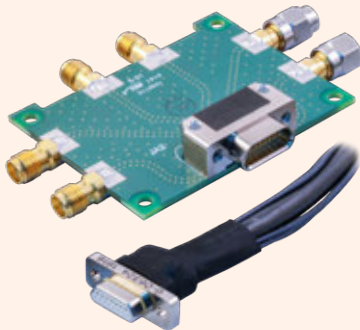

21	21	25	21
Display Port 1.2	HDMI 2.0	DVI-D Dual	DVI-D Single
9	15	9	15
eSATA/SATA 3	USB 3.0	USB 2.0	Up To: Cat 6A (10GBASE-T)

Micro-D High-Speed configurations include wired assemblies and straight or 90° PCB-mount connectors. Insert arrangements feature 1 Amp Nanominiature TwistPin contacts. Hybrid 1Amp/3Amp arrangements for USB 3.0 SuperSpeed are also available. All designs have been tested for today's popular high-speed protocols.

EMI SHIELDING AND ENVIRONMENTAL SEALING

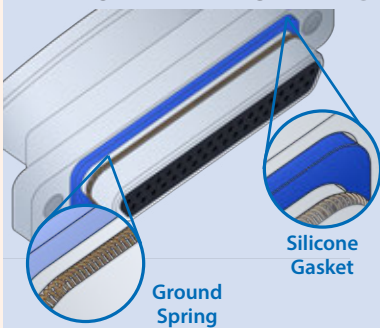

Plug connectors feature a gold-plated stainless steel ground spring for EMI protection, and a silicone gasket for environmental sealing.

High-Speed Micro-D contact arrangements face view pin connector

- high-speed signal pair
- signal-pair drain wire
- low-speed signal or power contacts

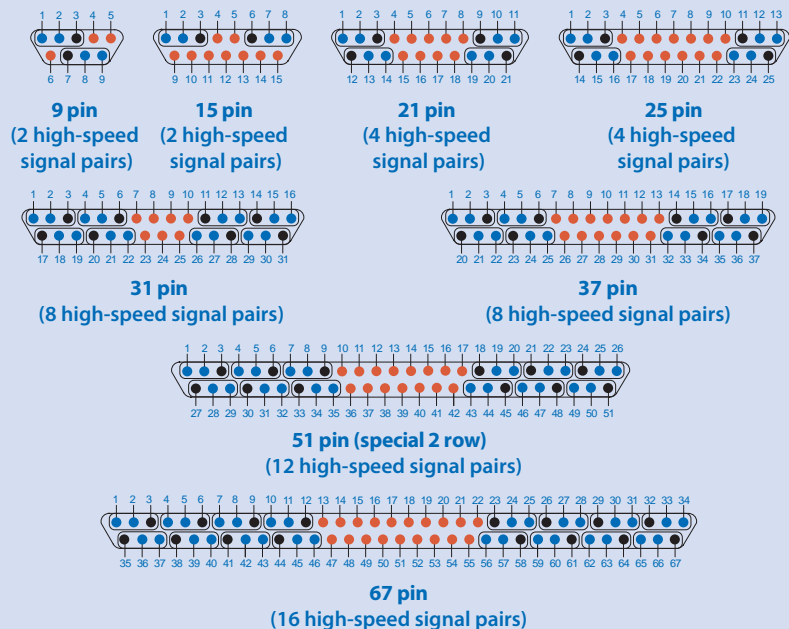

MATERIALS AND FINISHES

Connector Shell: Aluminum Alloy 6061
 Insulator: Polyphenylene Sulfide (PPS)
 Flange Seal: Fluorosilicone Rubber, Blue
 Pin Contact: Copper Alloy, Gold over Nickel Plating
 Socket Contact: Copper Alloy, Gold over Nickel Plating
 Ground Spring: Stainless Steel, Gold Plating
 Hardware: 300 Series Stainless Steel, Passivated
 Epoxy Resin Hysol EE4215 and Stycast 2850FT/Catalyst 11

*Contact factory for custom configurations supporting up to 3 Amps.

**Add (10 Ounces) X (# of 3 Amp Contacts) for mating force for configurations with 3 Amp contacts

PERFORMANCE SPECIFICATIONS

Current Rating: 1 Amp*
 DWV: 600 VAC Sea Level
 Insulation Resistance: 5000 Megohms Minimum (500 VDC)
 Contact Resistance: 80 Milliohms Maximum
 Operating Temperature: -55°C To 125°C
 Mating Force: (7 Ounces) X (# of 1 Amp Contacts)**
 Durability: 500 Mating Cycles



How-to-order GHSM Shielded Cable Assembly Connectors

How To Order High-Speed Micro-D Wired Connectors	
Sample Part Number	GHSM 2 R -31 P -A 8 J 1 -18 L A
Series	GHSM = Glenair High-Speed Micro-D
Shell Finish	2 = Nickel 5 = Gold
Insulator Material	R = PPS
Contact Layout	9, 15, 21, 25, 31, 37, 51-2, 67
Contact Type	P = Pin (Single-End Plug) S = Socket (Single-End Receptacle) GP = Double-End Cable, Pin Connectors Both Ends GS = Double-End Cable, Socket Connectors Both Ends CS = Double-End Cable, Pin and Socket
High Speed Cable Type	A = Glenair Cable 963-043-26 (100 Ohm, +105°C Max) B = Glenair Cable 963-129-28 (90 Ohm)
Discrete Wire Gage (AWG)	8 = #28 0 = #30 (J Wire Type only)
Discrete Wire Type	K = M22759/11 600 VRMS Teflon (TFE) J = M22759/33 600 VRMS Modified Cross-Linked Tefzel (ETFE)
Discrete Wire Color	1 = White 7 = Ten Color Repeating
Wire Length	Wire Length in Inches, 6 Inch Minimum
Mounting Hardware¹	L, M, P, S, (See Mounting Hardware Designations table below)
Shield and Jacket Option	X - ArmorLite Braided Microfilament Stainless Steel shield with E-CTFE Halar "Expando" Jacket W - ArmorLite Braided Microfilament Stainless Steel shield Z - 75% Braided AmberStrand shield with E-CTFE Halar "Expando" Jacket V - 75% Braided AmberStrand shield T - 100% Braided AmberStrand shield with E-CTFE Halar "Expando" Jacket S - 100% Braided AmberStrand shield C - Braided shield (Nickel Over Copper) with E-CTFE Halar "Expando" Jacket A - Braided shield (Nickel over Copper) N - No Shield, No Jacket (customer to install)

1 - Hardware is always required to ensure connector pair is fully mated when installed

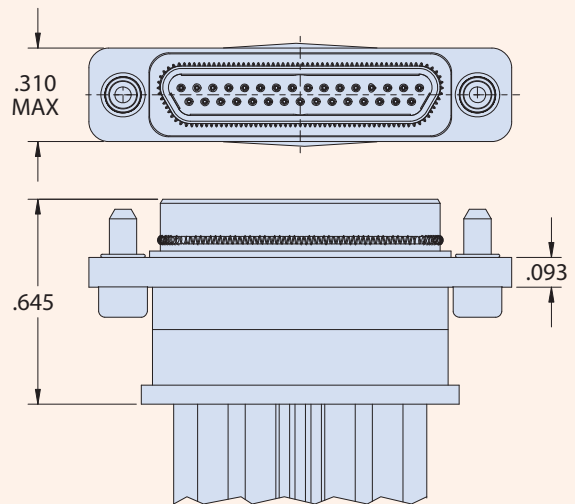
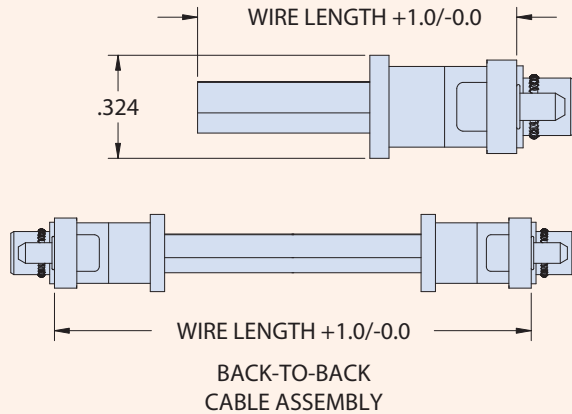

Mounting Hardware Designations			
P Jackpost	M Hex Head Jackscrew	S Slot Head Jackscrew	L Hex Head Jackscrew, Non-Removable

How-to-order

GHSM-BSS Board Straight Surface Mount Connectors

How To Order High-Speed Micro-D Board Straight Surface Mount Connectors	
Sample Part Number	GHSM 2 R -25 S BSS PU
Series	GHSM = Glenair High-Speed Micro-D
Shell Finish	2 = Nickel 5 = Gold
Insulator Material	R = PPS
Contact Layout	9, 15, 21, 25, 31, 37, 51-2, 67
Contact Type	P = Pin (Plug) S = Socket (Receptacle)
Termination Type	BSS = Board Straight Surface Mount
Jackpost Option (see table below)	PN = Extended Jackpost for .062" PCB RN = Extended Jackpost for .196" PCB PU = Short Jackpost and Threaded Insert Rear Panel Jackpost with Threaded Insert R2U = .032" Panel R3U = .047" Panel R4U = .062" Panel R5U = .094" Panel R6U = .125" Panel R7U = .080" Panel

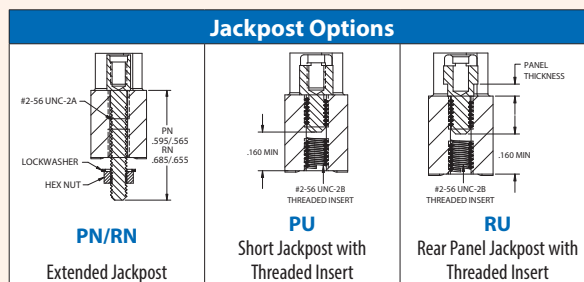
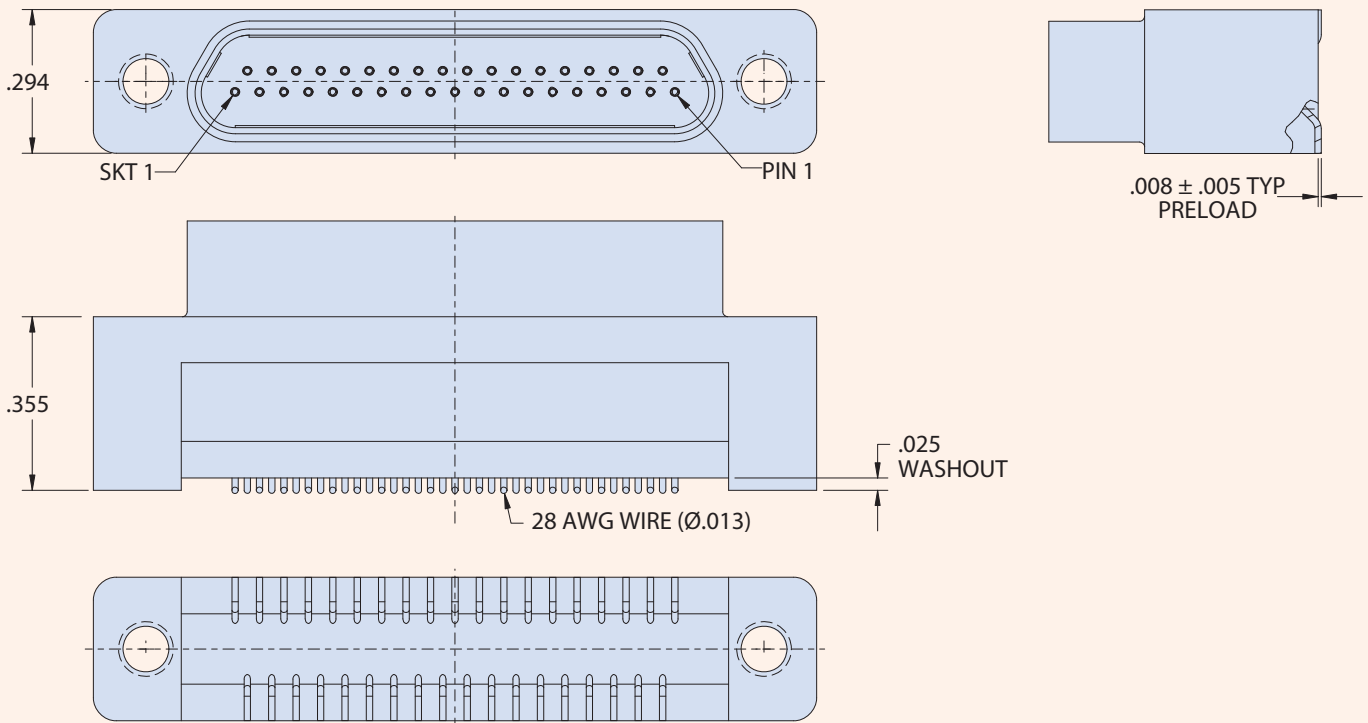

HIGH-SPEED Micro-D



How-to-order GHSM-HBR Hybrid Board Right-Angle connectors

How To Order High-Speed Micro-D Hybrid Board Right Angle Connectors										
Sample Part Number	GHSM	2	R	-25	S	HBR	P	T	-110	
Series	GHSM = Glenair High-Speed Micro-D									
Shell Finish	2 = Nickel 5 = Gold									
Insulator Material	R = PPS									
Contact Layout	9, 15, 21, 25, 31, 37, 51-2, 67									
Contact Type	P = Pin (Plug) S = Socket (Receptacle)									
Termination Type	HBR = Hybrid Board Right Angle									
Jackpost Option (see table below)	P = Jackpost		Jackposts for Rear Panel Mounting							
	L = Hex Head Jackscrew (non-removable)		R1 = .032" Panel	R2 = .047" Panel	R3 = .062" Panel	R4 = .093" Panel	R5 = .125" Panel	R6 = .080" Panel		
Threaded Insert Option	T = Threaded Insert in Board Mounting Hole Omit for Thru-Hole									
Right-Angle Lead Length	-.080, -.110, -.140, -.172 (Length in Inches ±.015)									

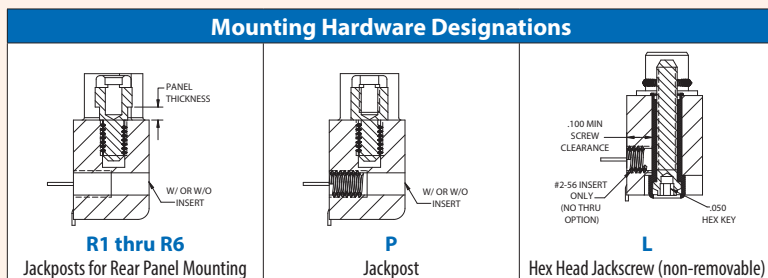
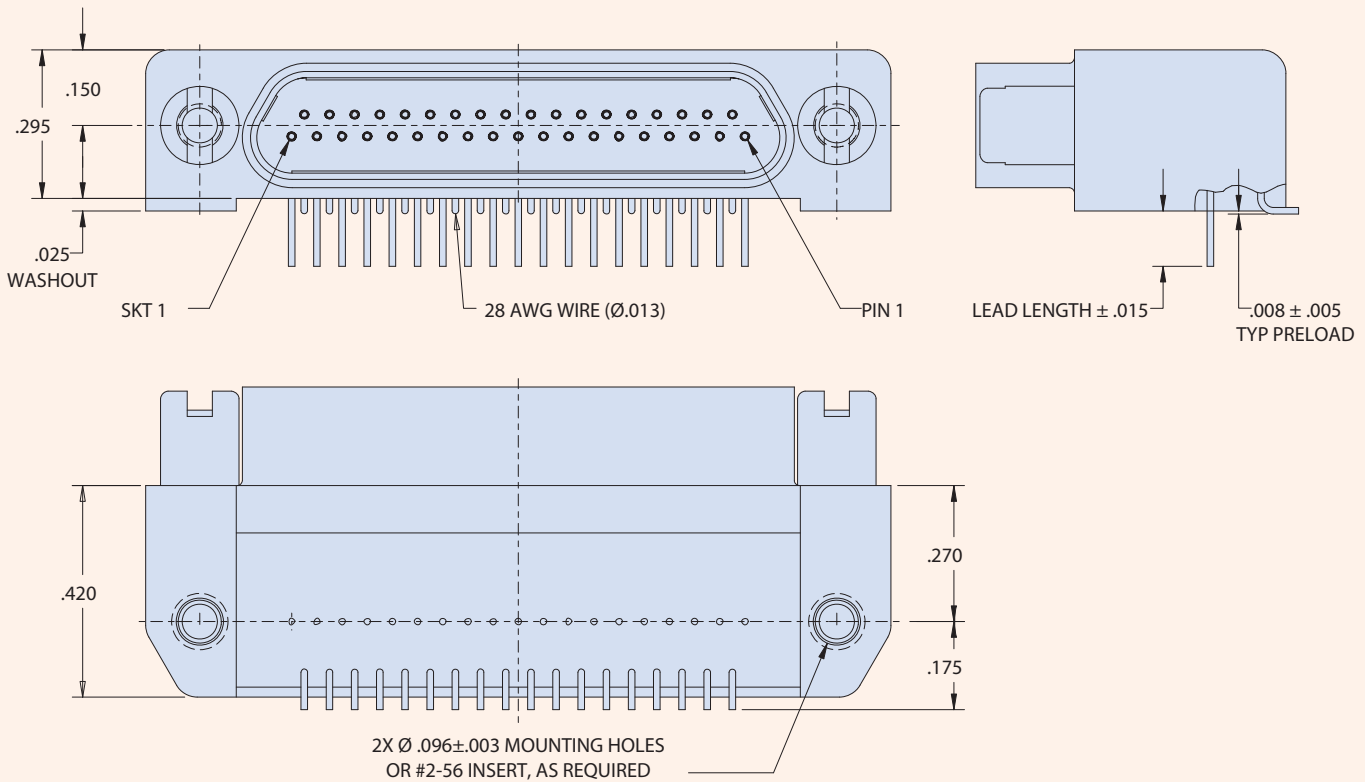

How-to-order GHSRPM Rear-Panel Mount Cable Assembly Connectors

How To Order High-Speed Micro-D Wired Connectors	
Sample Part Number	GHSRPM 2 R -31 P -A 8 J 1 -18 R3 N
Series	GHSRPM = Glenair High-Speed Micro-D, Rear Panel Mount
Shell Finish	2 = Nickel 5 = Gold
Insulator Material	R = PPS
Contact Layout	9, 15, 21, 25, 31, 37, 51-2, 67
Contact Type	P = Pin (Plug) S = Socket (Receptacle)
High Speed Cable Type	A = Glenair Cable 963-043-26 (100 Ohm, +105°C Max) B = Glenair Cable 963-129-28 (90 Ohm)
Discrete Wire Gage (AWG)	8 = #28 0 = #30 (J Wire Type only)
Discrete Wire Type	K = M22759/11 600 VRMS Teflon (TFE) J = M22759/33 600 VRMS Modified Cross-Linked Tefzel (ETFE)
Discrete Wire Color	1 = White 7 = Ten Color Repeating
Wire Length	Wire Length in Inches, 6 Inch Minimum
Mounting Hardware	R1 = .032" Panel R2 = .047" Panel R3 = .062" Panel R4 = .093" Panel R5 = .125" Panel R6 = .080" Panel
O-Ring Material	C = Conductive N = Non-Conductive (Nitrile)

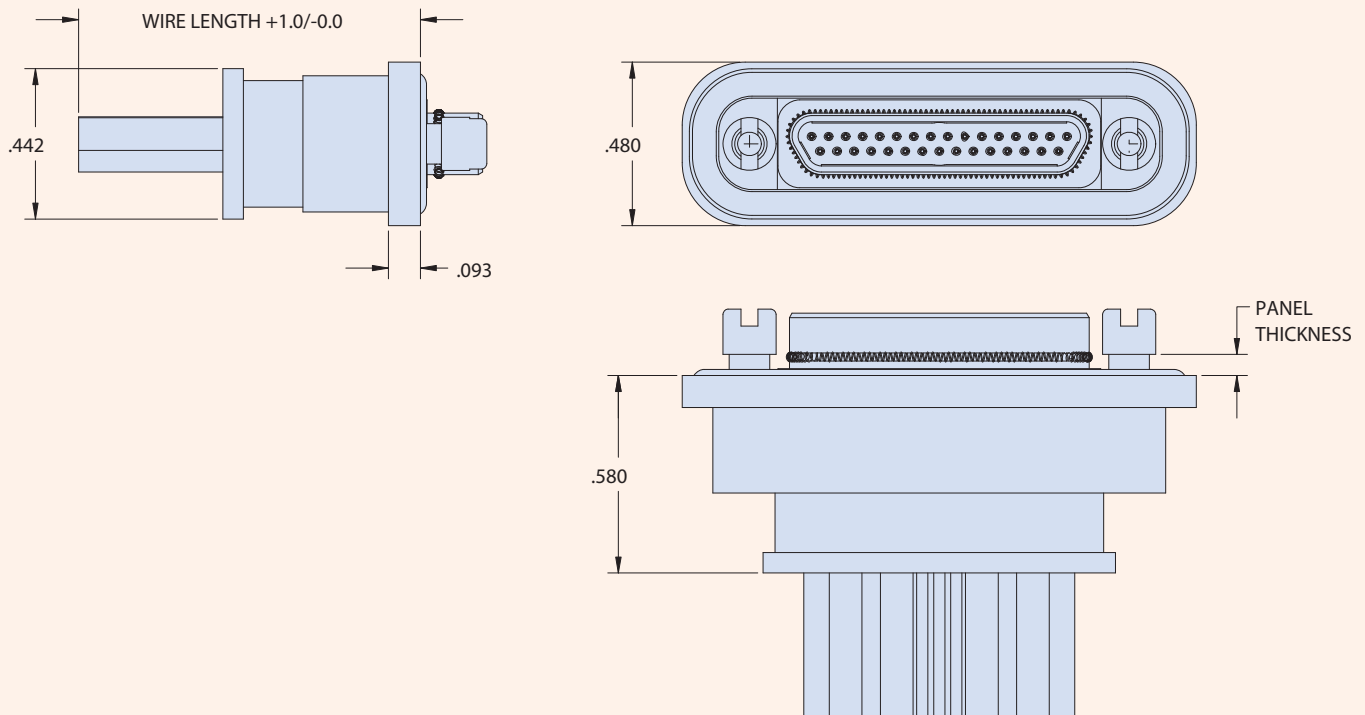

HIGH-SPEED Micro-D



How-to-order

GHSRPM-BSS Rear-Panel Board Straight Surface Mount connectors

How To Order High-Speed Micro-D Board Straight Surface Mount Connectors	
Sample Part Number	GHSRPM 2 R -25 P BSS R3 N
Series	GHSRPM = Glenair High-Speed Micro-D, Rear Panel Mount
Shell Finish	2 = Nickel 5 = Gold
Insulator Material	R = PPS
Contact Layout	9, 15, 21, 25, 31, 37, 51-2, 67
Contact Type	P = Pin (Plug) S = Socket (Receptacle)
Termination Type	BSS = Board Straight Surface Mount
Rear Panel Mount Hardware Option	R2U = .032" Panel R3U = .047" Panel R4U = .062" Panel R5U = .094" Panel R6U = .125" Panel R7U = .080" Panel
O-Ring Material	C = Conductive N = Non-Conductive (Nitrile)

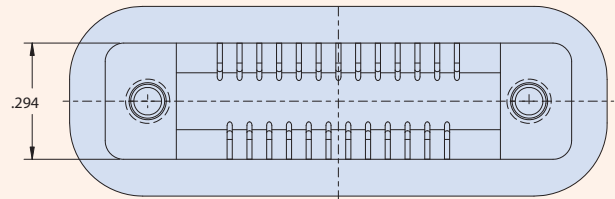
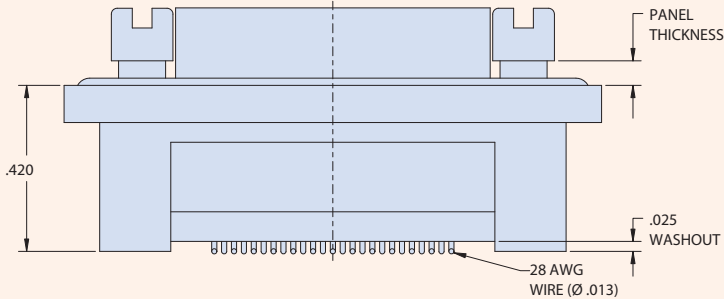
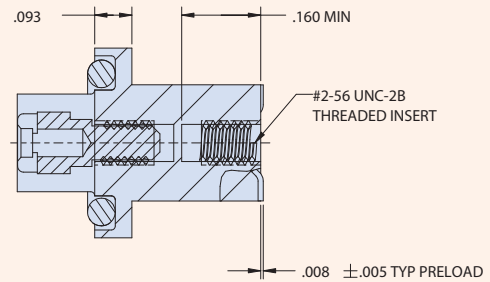
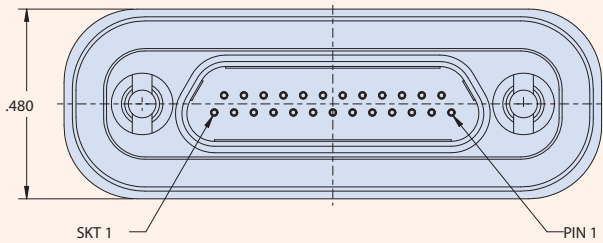

How-to-order GHSRPM-HBR Rear-Panel Hybrid Board Right-Angle Connectors

How To Order High-Speed Micro-D Hybrid Board Right Angle Connectors											
Sample Part Number	GHSRPM	2	R	-25	P	HBR	R3	T	N	-.110	
Series	GHSRPM = Glenair High-Speed Rear-Panel Micro-D										
Shell Finish	2 = Nickel 5 = Gold										
Insulator Material	R = PPS										
Contact Layout	9, 15, 21, 25, 31, 37, 51-2, 67										
Contact Type	P = Pin (Plug) S = Socket (Receptacle)										
Termination Type	HBR = Hybrid Board Right Angle										
Rear Panel Mount Hardware Option	R1 = .032" Panel R2 = .047" Panel R3 = .062" Panel R4 = .093" Panel R5 = .125" Panel R6 = .080" Panel										
Threaded Insert Option	T = Threaded Insert in Board Mounting Hole Omit for Thru-Hole										
O-Ring Material	C = Conductive N = Non-Conductive (Nitrile)										
Right-Angle Lead Length	-.080, -.110, -.140, -.172 (Length in Inches ±.015)										

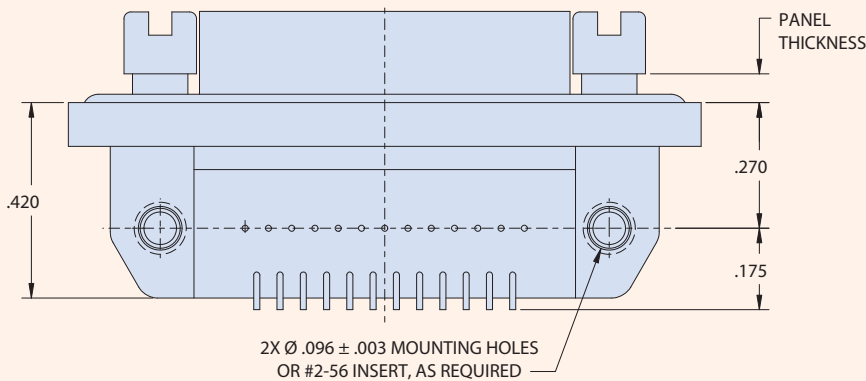
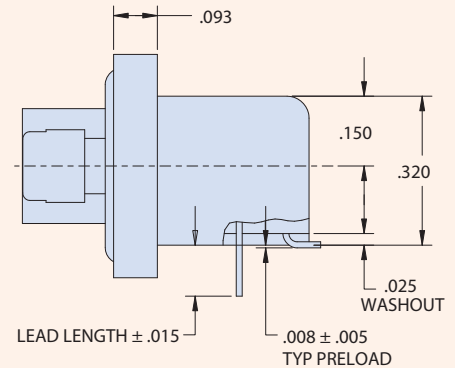
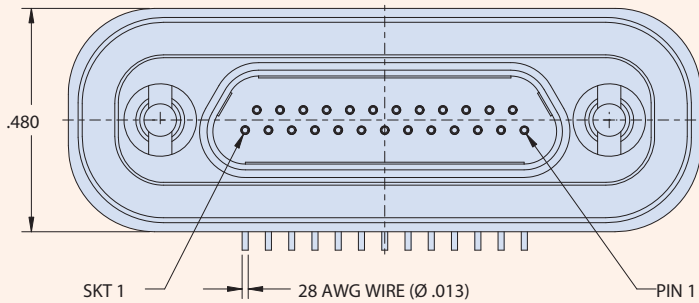

HYBRID
ELECTRICAL /
OPTICAL
SOLUTIONS

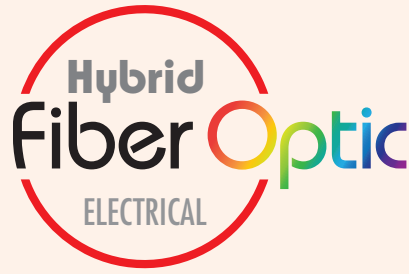

**Hybrid Electrical /
Optical Connectors
for Special Applications**



Ruggedized aerospace equipment such as mission computers are occasionally best served by an I/O connector interface that combines both fiber optic and electrical media. For example, where limited available panel space makes multiple connector penetrations difficult, or in situations where a remote piece of fiber optic equipment requires electrical power.

- Available hybrid circular connector packaging includes MIL-DTL-38999 Series III type, Series 80 Mighty Mouse, and more
- Available hybrid rectangular connector packaging includes MIL-PRF-83513 Micro-D and Glenair Signature Series 79
- Expanded-beam solutions include Eye-Beam GLT (grin lens terminus) and Eye-Beam GMA (ball lens)



Hybrid optical / electrical
MIL-DTL-5015 (Series ITS type)

RUGGEDIZED
Hybrid Electrical / Optical Connectors
Product showcase



Harsh-environment marine bronze jam-nut connector, hybrid arrangement with #8 opto-electronic converter contacts and size #12 and #20 electrical contacts

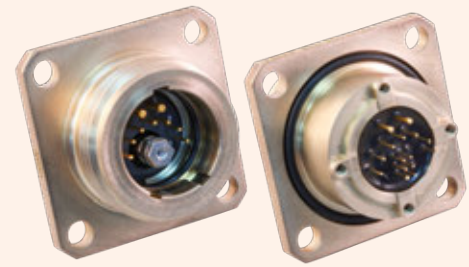

Harsh-environment marine bronze jam-nut connector, hybrid arrangement with #8 opto-electronic converter contact and size #12 and #20 electrical contacts



Series 805 Mighty Mouse with hybrid size #8 opto-electronic contact and size #23 signal contacts



D38999 Series III type wall-mount receptacle with mixed butt-joint and expanded beam fiber optic contacts

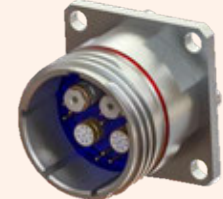

D38999 Series III type wall-mount receptacle with opto-electronic, El Ochito octaxial, and standard signal contacts

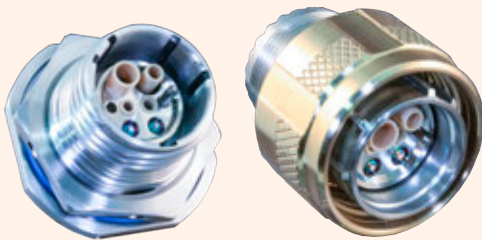

Harsh-environment Geo-Marine connector pair with hybrid expanded-beam fiber optic / signal contact arrangement



Mighty Mouse push-pull QDC connector with mixed fiber optic and signal contacts



Series 79 micro-crimp rectangular with hybrid signal / Eye-Beam GLT expanded beam F/O arrangement



M83513-type Micro-D connectors with hybrid fiber optic / TwistPin signal contacts



Rugged ITH 5015-type reverse-bayonet industrial / rail connector pair with Eye-Beam GLT expanded beam fiber optic contacts and size #16 signal contacts



Rugged IPT threaded rail connectors with Eye-Beam GMA ball-lens insert fiber optic contacts and size #16 signal contacts



MISSION-CRITICAL INTERCONNECT SOLUTIONS

Glenair, Inc.

1211 Air Way • Glendale, California • 91201-2497

Telephone: 818-247-6000 • Fax: 818-500-9912 • sales@glenair.com

www.glenair.com

Glenair Power Products Group

20 Sterling Drive
Wallingford, CT
06492

Telephone:
203-741-1115
Facsimile:
203-741-0053
sales@glenair.com

Glenair UK Ltd

40 Lower Oakham Way
Oakham Business Park
Mansfield, Notts
NG18 5BY England

Telephone:
+44-1623-638100
Facsimile:
+44-1623-638111
sales@glenair.co.uk

Glenair Microway Systems

7000 North Lawndale Avenue
Lincolnwood, IL
60712

Telephone:
847-679-8833
Facsimile:
847-679-8849

Glenair Nordic AB

Gustav III : S Boulevard 42
SE-169 27 Solna
Sweden

Telephone:
+46-8-50550000
sales@glenair.se

Glenair GmbH

Schaberweg 28
61348 Bad Homburg
Germany

Telephone:
06172 / 68 16 0
Facsimile:
06172 / 68 16 90
info@glenair.de

Glenair Iberica

C/ La Vega, 16
45612 Velada
Spain

Telephone:
+34-925-89-29-88
Facsimile:
+34-925-89-29-87
sales@glenair.es

Glenair Italia S.p.A.

Via Del Lavoro, 7
40057 Quarto Inferiore –
Granarolo dell'Emilia
Bologna, Italy

Telephone:
+39-051-782811
Facsimile:
+39-051-782259
info@glenair.it

Glenair France SARL

7, Avenue Parmentier
Immeuble Central Parc #2
31200 Toulouse
France

Telephone:
+33-5-34-40-97-40
Facsimile:
+33-5-61-47-86-10
sales@glenair.fr

Glenair Korea

6-21Tapsil-ro 58beon-gil
Giheung-gu, Yongin-si
Gyeonggi-do
Republic of Korea

Telephone:
+82-31-8068-1090
Facsimile:
+82-31-8068-1092
sales@glenair.kr

© 2020 Glenair, Inc.

Printed in U.S.A.