

# ATRO

ENGINEERED SYSTEMS



# FIELD MANUAL:

*SUSPENSIONS  
& TRAILERS*

CHALMERS | FREIGHTLINER | HENDRICKSON | HUTCHENS  
INTERNATIONAL | KENWORTH | MACK | MERITOR  
PETERBILT | REYCO | VOLVO

# With ATRO behind you, drive forward.



## CHEMICALLY RESISTANT

Impervious to:

- Oil / Grease
- Brine
- Cleaning Solvents
- Hydraulic Fluids
- Diesel Fuel
- Rubber Deteriorates



## CUSTOMIZED FORMULAS

- Engineered to Function
- Providing Peak Performance
- Improving Ride Quality
- Absorbs Shock or Transfers Energy
- Exceeds OEM Specs
- Longer Lasting Parts



## STRONGER MATERIAL

- 2-5 Times Stronger
- Rebound & Compression
- Tensile & Tear Strength
- Elongation Properties
- Ranging Durometer



1-800-325-6114  
ATROBUSHING.COM



# CONTENTS

<b>Suspensions At-A-Glance</b> .....	<b>2</b>
Suspension Basics.....	6
Air Suspension Inspection/Maintenance.....	7
Leaf Spring Inspection.....	8
Most Common & Preventable Failures.....	9

## Truck Rear Suspensions

Chalmers - 800 Series.....	10
Freightliner - FASII.....	14
Freightliner - TufTrac.....	16
Hendrickson - Haulmaax.....	18
Hendrickson - HN.....	22
Hendrickson - Primaax.....	24
Hendrickson - RS.....	26
Hendrickson - RT.....	28
International - Corporate Air/IROS.....	30
Kenworth - AirGlide 100.....	32
Kenworth - AirGlide 200/400.....	34
Kenworth - AirGlide 380/Peterbilt - Flex Air.....	36
Mack - Camelback.....	38
Mack - AL40.....	40
Neway AD.....	42
Neway ADZ.....	44
Peterbilt - Air Leaf.....	46
Peterbilt - Air Trac.....	48
Peterbilt - Low Mount Air Leaf.....	50
Peterbilt - New Low Air Leaf.....	52
Volvo Corporate Air Ride.....	54
Volvo T-Ride.....	56

## Trailer Suspensions

Hendrickson - Intraax/Vantraax.....	58
Hutchens - H/CH 7700/9700.....	62
Meritor-RHP/MPA.....	64
Reyco-21B.....	66

## Torque Rods.....

Identify a Torque Rod.....	70
Identify a Taper Pin Bushing.....	71
ATRO's Torque Rod Finder.....	72
ATRO Torque Rods Benefits.....	74
ATRO Torque Rod Information Charts.....	75
Failed Torque Guide.....	76

Copyright © 2022 by ATRO, LLC ALL RIGHTS RESERVED. This book contains material protected under International and Federal Copyright Laws and Treaties. Any unauthorized reprint or use of this material is prohibited. No part of this book may be reproduced or transmitted in any form or by any means, electronic or mechanical, including photocopying, recording, or by any information storage and retrieval system without express written permission from ATRO, LLC.

ATRO, LLC is not liable for any errors herein. All manufacturers' names and part numbers used are trademarked by the respective manufacturer. These names and part numbers are being used without permission. No endorsement, affiliation or recommendation is implied. They are included for reference purposes only.

**CHALMERS - Page 10**



**FREIGHTLINER FASII - Page 14**

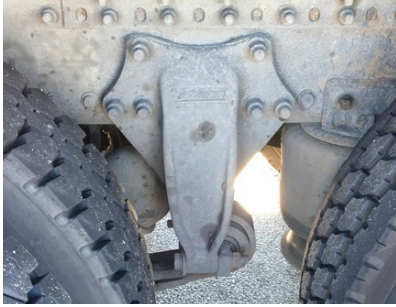

**FREIGHTLINER TUFTRAC - Page 16**



**HENDRICKSON HAULMAAX - Page 18**



**HENDRICKSON HN - Page 22**



**HENDRICKSON PRIMAAX - Page 24**



**HENDRICKSON RS - Page 26**



**HENDRICKSON RT - Page 28**





**INTERNATIONAL CORP AIR/IROS - Page 30**



**KENWORTH AIRGLIDE 100 - Page 32**



**KENWORTH 200/400 - Page 34**



**KENWORTH AG380/PETERBILT FLEX AIR - Page 36**



**MACK CAMELBACK - Page 38**



**MACK AL40 - Page 40**



**NEWAY AD - Page 42**



**NEWAY ADZ - Page 44**





**PETERBILT AIR LEAF - Page 46**



**PETERBILT AIR TRAC - Page 48**



**PETERBILT LOW MOUNT AIR LEAF - Page 50**



**PETERBILT LOW LOW AIR LEAF/KENWORTH  
AG 400 L - Page 52**



**VOLVO CORPORATE AIR RIDE - Page 54**

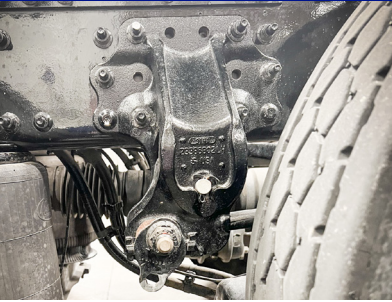

**VOLVO T RIDE - Page 56**



**HENDRICKSON INTRAAX/VANTRAAX -  
Page 58**



**HUTCHENS - Page 62**





# ATRO'S CARRIER BEARINGS

## CR00-67661

### Carrier Bearing Assembly, Self-Aligning

Bearing Angular Allowance: +/-10 degrees

Dana - Spicer: 10094142, 2106611X, 5003323, SP5003323

### FEATURES & BENEFITS

#### Polyurethane

- Chemically Resistant
- Vibration Absorbing

#### Patented Pivoting Bearing

- ± 10° of Articulation
- Sealed Unit
- Prevents Contamination
- Retains Lubricant

#### Heavy Duty Steel Housing

- 7 Gauge Steel

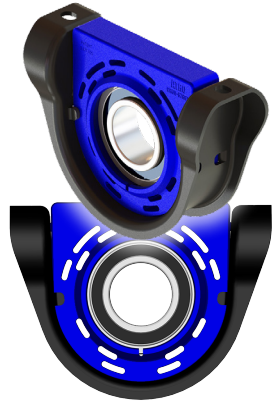

## CR00-67825

### Carrier Bearing Assembly, Series 1810

Spicer: 2106611X, 5003323

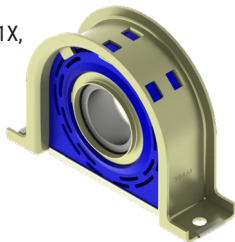

## CR00-67121

### Carrier Bearing Assembly, Series 1710

Spicer: KCB121; 210121-1X

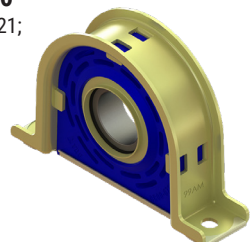

# SUSPENSION BASICS

- A suspension is a system that relies on all the components working in harmony to perform their given function.
- When one part gets worn, the rate of stress transfer to other parts accelerates, so early detection of any wear will prevent major repairs and provide long-term savings for the truck owner.

## Suspensions are designed to

- Carry the load
- Provide stability against side sway
- Transfer driving & braking forces between frame and axles
- Resist drive & brake torque wind-up
- Produce suitable riding and cushioning properties
- Maintain axle alignment parallel to each other and perpendicular to the frame
- Provide minimum changes in drive axle pinion angles and slip joint movement
- Minimize load transfer between axles on tandems
- Provide sufficient vertical movement on tandems to maintain traction

## Components making up the suspension system include

- Leaf springs
- Air springs
- Torque rods
- Bushings
- Spring pins/Shackle kits
- U-bolts
- Shocks

## DID YOU KNOW?

A truck can have one of many types of suspensions. A key method to identify which type you have, is to look between the wheels and identify the visual elements that match closest to your suspension. You can find a helpful visual guide to a variety of suspensions on pages 2 – 5.



# AIR SUSPENSION INSPECTION & MAINTENANCE

---

## 1.) Leaking air or restricted air flow

- If both sides are flat, there may be a leak between the air brake system and the suspension air system
- If flat on one side, there may be a leak between the height control valve and the air spring

## 2.) Automatic height control valve

- Test it: disconnect linkage and move actuating arm up and down to see if air bag inflates/deflates

## 3.) Bushings

- Place pry bar between trailing arm and hanger and check for movement – abnormal tire wear is a good indicator of bushing wear

## 4.) Shocks – should be warm to the touch after vehicle operation

- If cold, the shock is not functioning properly and should be replaced
- If shock can be easily compressed after removal, shock should be replaced
- Check for shock bushing wear

## 5.) Air bag inflation

- Slight positive pressure maintains shape of air bag and prevents folding/pinching

## 6.) Causes of air spring failure

- Overextension
- Abrasion
- Contamination
- Suspension Misalignment
- Road Hazards
- Fatigue / Old Age

# LEAF SPRING INSPECTION

## Items to Check

- Spring leaves
- Center bolt
- U-bolt nuts for tightness
- Spring clips
- Spring eyes (cracks, motion, lubrication)
- Front suspension spring shackle bolts
- Torque rods and all other related parts of spring suspensions: Hangers, equalizers, beam bushings
- Shock absorbers

## Common Leaf-Spring Suspensions

- Hendrickson RT
- Mack Camelback



## Common Air Suspensions

- Freightliner FASII
- Kenworth Airglide 400
- Peterbilt Air Leaf
- Peterbilt Air Trac



## Common Elastomer Spring

- Chalmers 800
- Hendrickson RS
- Hendrickson HN
- Hendrickson Haulmaax



# MOST COMMON & PREVENTABLE FAILURES

## U-bolts

- Never re-use U-bolts!
- Check they are the proper grade
- Ensure proper alignment (check condition of top plate and saddle alignment holes)
- Allow suspension to settle, re-torque while under load.
- Torque U-bolts per specifications – re-torque at 500 miles and check periodically

## Springs

- Proper U-bolt maintenance will increase spring life but springs will fatigue and wear
- Cracks are the primary sign of fatigue
- One overlooked factor in spring longevity is brake balance; a poorly adjusted brake makes the other brakes overcompensate and the spring at those axle ends will get “wound up” more than if all brakes are pulling equally

## Torque Rod Neglect

- Affects spring life, bushings, brackets, bolsters, shocks, air bags and other suspension hardware
- Check for failure periodically – especially transverse rods

## Lubrication Failures

- Inhibits normal free movement, resulting in part breakage
- Wear is accelerated; wear patterns are exaggerated

## Bushing Failures

- Waiting to replace worn bushings until after they’ve created a secondary, more expensive problem

## Shock Absorber Neglect

- Affects spring life, bushings and other suspension hardware causes additional strain and vibration on radiators, electrical systems, cabs and tires, defective shocks can also contribute to air bag failure



# CHALMERS

The Chalmers 800 Series suspension is a walking beam-style tandem axle rear suspension that uses two large elastomeric load springs and eight large torque rods, four upper and four lower. This design allows for a large degree of articulation so the load is equalized while keeping the tires in contact with the ground.

## ATRO Load Springs Provide Key Benefits Over Rubber

- Resistant to chemicals (lime, corrosive solvents, road wash)
- Better load handling and ride characteristics than OEM rubber and other polyurethane brands
- Will not take a permanent compression set like rubber springs, keeping ride height accurate and driveline angles in spec

ATRO PART NUMBER	OEM PART NUMBER	AXLE RATING
LP19-24002	OEM #15002	20,000 lbs
LP19-24015	OEM #15015	15,000 lbs
LP19-24026	OEM #15026	26,000 lbs

## ATRO Torque Rod Bushing Options

- 2-piece design – 32/suspension (PL1046, PL1047); oversized option is PL1049
- 1-piece design – 16/suspension (TH19-22010, TH19-22128); oversized option in TH19-22129

ATRO's 2-piece torque rod bushings make installation easier and faster. With limited installation clearance, 2-piece bushings are placed on each dowel pin on opposite sides and ends. Then the rod with the other halves loaded are positioned on the dowels. Finish the repair by placing and tightening the spigot cap.



**TECH TIP** Change one rod at a time! Otherwise, axles will slide and make re-installation of rods very difficult.

BOLT SIZE	ASSEMBLY TORQUE FT. LBS.
3/8"	35
1/2"	65
5/8"	135
3/4"	250-280*



### WEAR ITEMS

- Rubber load springs, subject to chemical attack will take a compression set over time. This negatively affects the vehicle's ride height, which puts the angle of the driveline out of OEM specs, resulting in other problems including U-joint and carrier bearing failures
- Torque rod bushings

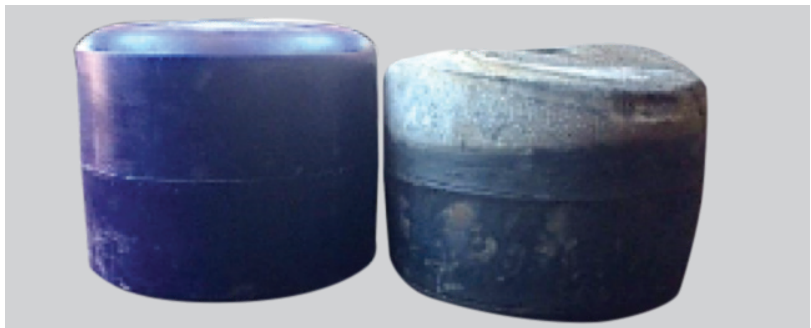
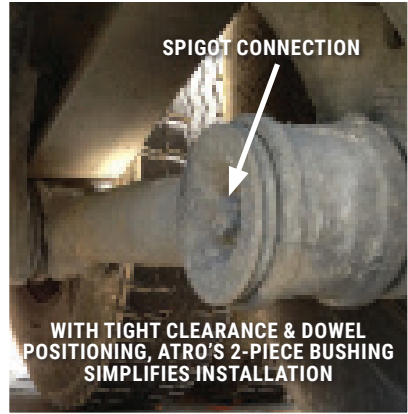
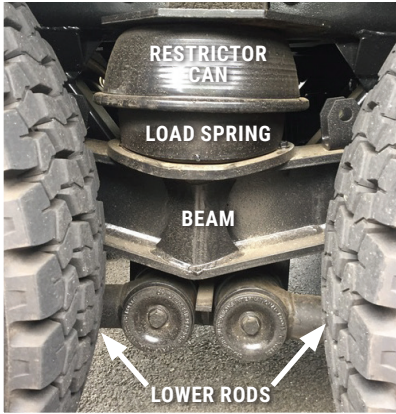

**LOAD SPRING SUBJECT TO CHEMICAL ATTACKS AND SHOULD BE REPLACED WHEN WORN. OTHERWISE RIDE HEIGHT WILL BE AFFECTED, CAUSING NUMEROUS ISSUES.**

## Key Parts

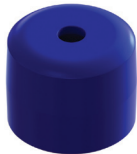

### LOAD SPRINGS

LP19-24002  
LP19-24015  
LP19-24026

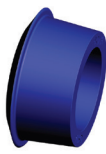

### 2-PC BUSHINGS

PL1046  
PL1047  
PL1049



### 1-PC BUSHINGS

TH19-22010  
TH19-22128  
TH19-22129

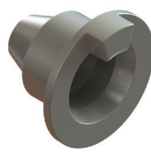

### SPIGOT CAPS

MS19-29002  
MS19-29201  
MS19-29055



### RESTRICTOR CANS

MS19-29028  
MS19-29029

Scan QR Code to go to video:  
**ATRO Parts | Chalmers Suspensions**



# CHALMERS

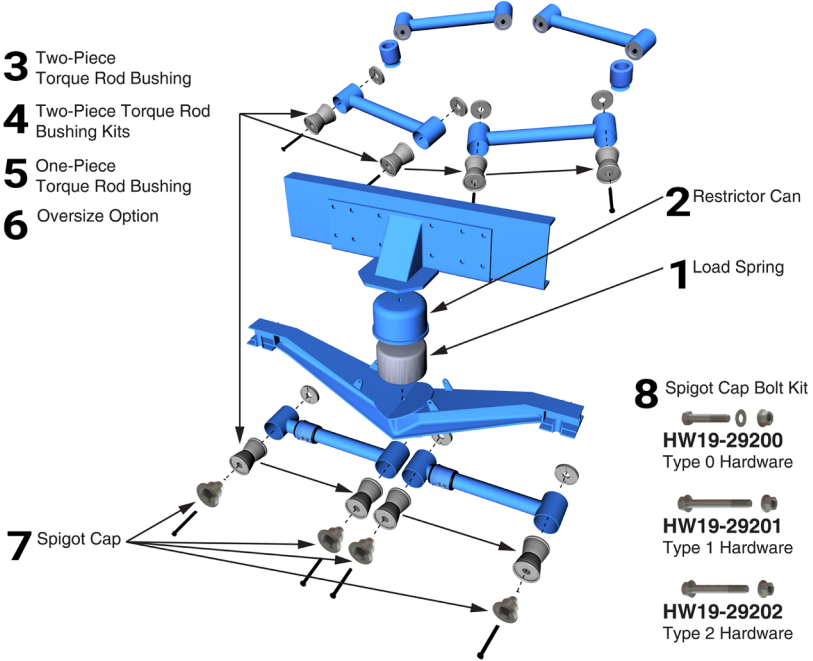

LOAD SPRING & RESTRICTOR CAN			
Number on Schematic	1	2	
Chalmers 800 Tandem Suspensions	ATRO Load Spring	ATRO Restrictor Can	
40K	LP19-24002 (8.0 H x 9.5 OD)	MS19-29028 Standard or MS19-29029 In High Center of Gravity Applications	
46K			
50K			
58K			
65K	LP19-24026 (8.0 H x 10.75 OD)	ATRO doesn't offer Restrictor Can	
80K			
100K			



## Torque Rod Bushing Kits

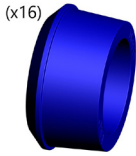

**KT19-22000**  
Contains:  
(16) PL1047

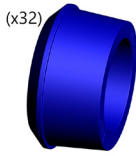

**KT19-22001**  
Contains:  
(32) PL1047

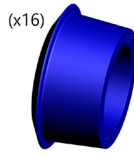

**KT19-22002**  
Contains:  
(16) PL1046

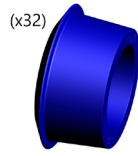

**KT19-22003**  
Contains:  
(32) PL1046



### BENEFIT:

ATRO's two-piece bushings allow for easier installation by eliminating the interference between the spigot and ID. Simply slide one half of the two-piece bushing over opposite spigot ends and install the bare rod, install the second half of the bushings, caps and bolts. Reduces install time by 30% to 50%.



Scan code for other  
Chalmers Suspension versions

### TORQUE ROD BUSHINGS, CAPS AND BOLT KITS

	3	4	5	6	7	8
	Two Piece Option	Torque Rod Bushing Kit	One Piece Option	Oversize Option	Spigot Cap	Spigot Cap Bolt Kit
	PL1047	KT19-22000 (PL1047 x 32) KT19-22001 (PL1047 x 16)	TH19-22128	TH19-22129 (1 Piece Only)	Type '1' MS19-29201	HW19-29201
	PL1046	KT19-22002 (PL1046 x 32) KT19-22003 (PL1046 x 16)	TH19-22010	PL1049 (2 Piece Only)	Type '2' MS19-29055	HW19-29202
	PL1046	KT19-22002 (PL1046 x 32) KT19-22003 (PL1046 x 16)	TH19-22010	PL1049 (2 Piece Only)	Type '2' MS19-29055	HW19-29202

# FREIGHTLINER FAS II

The FAS II is very popular in over-the-road applications with few parts to maintain. It is designed to cushion load and reduce sway in turns. It features an underslung parabolic leaf spring trailing arm.

## ATRO Spring Pin Solution (PB46-26268; UB20500-OS)

- Rotating pin design with flanged outer sleeve limits travel
- The revolving inner pin eliminates bushing wind-up and prevents entire bushing spinning
- UB20500-OS, an over-sized version (+.060"), is available if the rubber bushing has opened up the spring eye slightly. The spring must still meet specifications. If not, the spring must be replaced, not rebushed

## ATRO Torque Rods

- ATRO offers complete replacement rods for the three different length options
  - TR46-41716 (23 15/16")
  - TR46-41316 (22 7/8")
  - TR46-41002 (24 5/16")
- The bushing in all three ATRO rods is TS00-22500 – it has a 2" OD and will not fit OEM or other aftermarket rods. ATRO added an outer sleeve to extend bushing life also allowing for pin rotation that results in easier bolt hole alignment
- To rebush an OEM rod or other aftermarket rod for this application, use ATRO's non-rotating TS50-22691 (retaining rims) or PL1146 (no retaining rims, easy installation), which have no outer sleeve and the standard 1 7/8" outer diameter



### WEAR ITEMS

- The biggest concern is the OEM bonded rubber bushing in the leaf spring trailing arm. The spring eye opens up and results in bushing walk-out.
- The bonded OEM-style rubber bushing does not allow the pin to rotate. Thus, the ENTIRE bushing can be forced to spin, wallowing out the spring eye. The OEM has used multiple designs to solve this including the standard design, high-confinement design and the current anti-walk version.



Scan QR Code to go to video:  
**ATRO Parts | Freightliner FAS II  
Suspension**

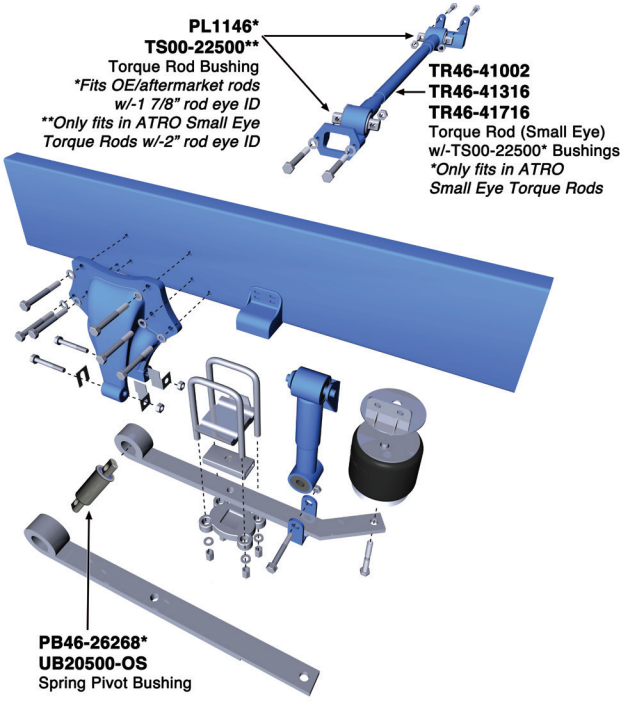
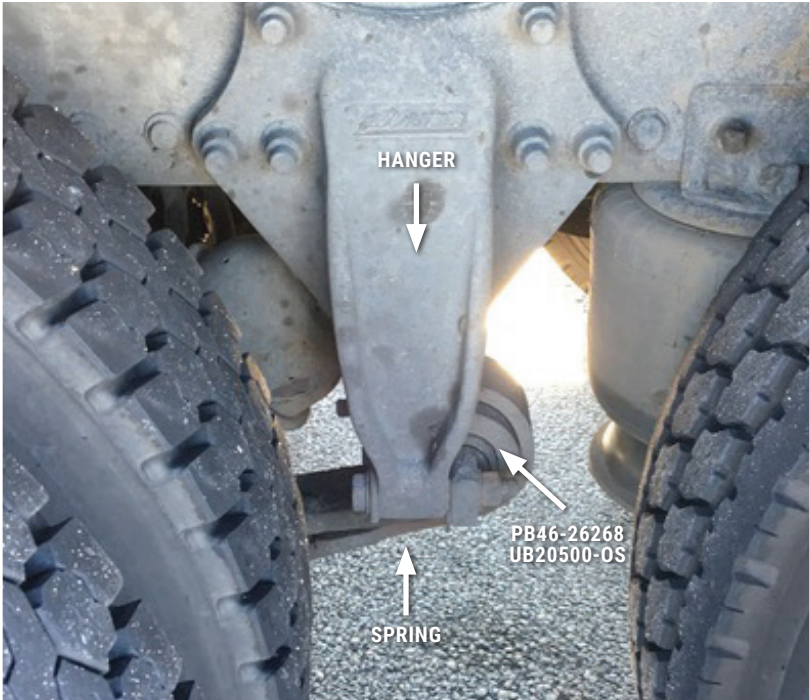

# FREIGHTLINER TUFTRAC

This vocational suspension combines parabolic springs with elastomeric load cushions. The center elastomer load cushion acts as a pivot point to allow articulation while smoothing out the typically harsher ride experienced with spring-only suspensions. The end spring pads cushion the ride, especially unladen, and reduce noise and vibration. This suspension design also raises the undercarriage components for more ground clearance.

Vocational uses include refuse, construction, asphalt spreader, heavy hauling, mining, logging, oil/gas field service and high-center-of-gravity applications; 40k, 46k and 52k capacities.

The OEM offers two options for the 40k and 46k models: TufTrac and 2-Stage TufTrac. The 2-Stage version uses a center bearing with a softer spring rate due to voids in the rubber material between the steel plates.

## ATRO offers the upper and lower spring end pads, lower torque rods and torque rods bushings

- Upper and lower spring end pads – ATRO’s load spring with proprietary polyurethane specifically formulated to resist compression set while absorbing shock and dampening vibration rather than transferring it into the spring or frame.
  - LP46-24808 – upper pad, 40k suspension
  - LP46-24581 – upper pad, 46k suspension
  - LP46-24807 – lower pad, used on both 40k & 46k suspension
- Lower torque rods – The OEM uses two different rods in the front and rear locations that are identical except for the bushing orientation within the rod.
- Torque rod bushings – eliminates part numbers with a 360° rotation of the inner pin.
  - TR46-49002 – used on 40k suspension with 54” axle spacing
  - TR46-49004 – used on 46-52k suspension with 60” axle spacing
  - TR46-49998 – used on 46-52k suspension with 56” axle spacing
  - These ATRO rods above do not accept the OEM snap ring-style bushing.
- Torque rod bushing for rebushing any of the lower rods
  - TS46-22300 - fits all lower ATRO rods- does not fit OEM rods.
  - Has rotating pins for easy installation and elimination of torsional stress



### WEAR ITEMS

- End load pads
- Lower torque rod/bushings

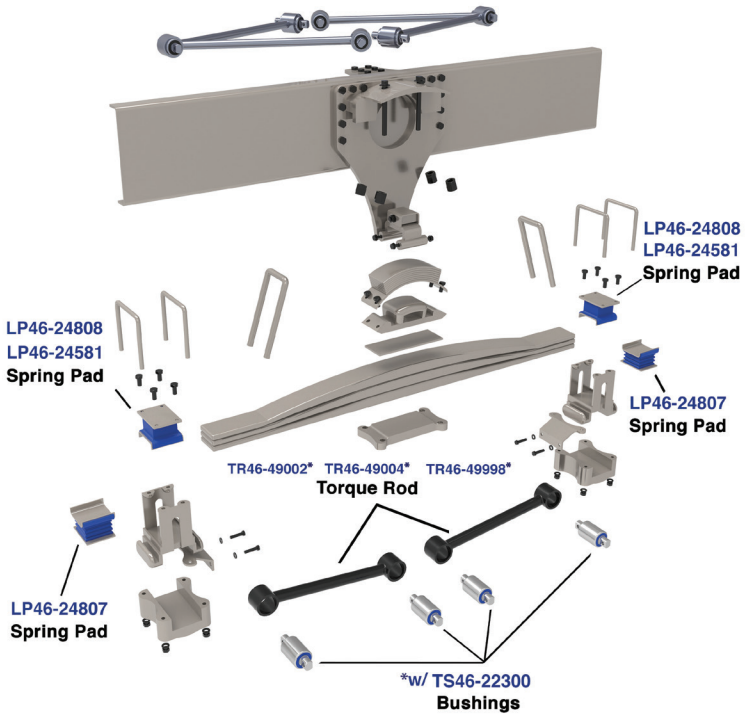



# HENDRICKSON HAULMAAX

This walking beam suspension is similar in design to the Hendrickson HN suspension. It features bar pin end bushings but there are no center bushings for the beams to pivot on. Like the HN, the traditional center bushing is replaced by four narrow bolster springs (eight per vehicle.) The center of gravity has been lowered by designing the narrow bolster to straddle the beam in pairs compared to the HN where large single bolsters are mounted atop the walking beam.

## ATRO Key Benefits

ATRO's polyurethane material in the bolster springs and progressive auxiliary spring is impervious to chemical attack.

After 1.75 million cycles of testing, ATRO Haulmaax bolster springs took 51% less compression set (or ride height loss) vs OEM rubber bolster springs.

The new style LP50-24778, Progressive Auxiliary Spring, replaced the smaller old style auxiliary spring, LP50-24974, in 2014. It is important to replace the old style with the new style on both sides of the truck. To install the new style progressive auxiliary spring it may be necessary to remove shim and/or raise the frame. Search [ATROBUSHING.COM](http://ATROBUSHING.COM) for Install Instructions: DC001-022615.

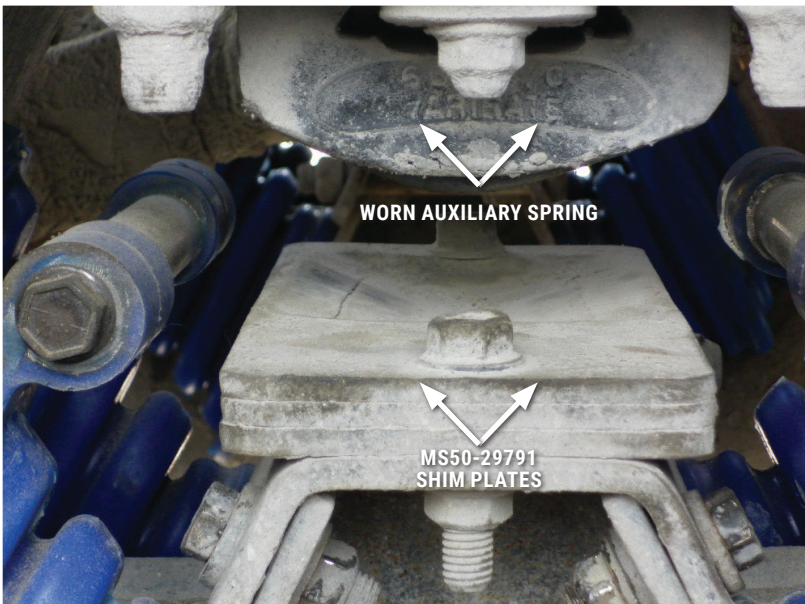





### TECH TIP

- ATRO's progressive load spring, LP50-24778, is required when using ATRO bolsters.
- Load spring is not an overload spring or a bump stop and it is designed to carry up to 40% of the load.
- **When properly installed, the Progressive Load Spring just touches the contact plate on the saddle. Plates may need to be added or removed.**



#### PREFERRED UPDATED LOAD SPRING

LP50-24745  
with hardware

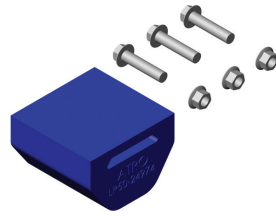

#### OUTDATED STYLE LOAD SPRING

No longer recommended on haulmaax  
LP50-24974



### WEAR ITEMS

- Transverse rods are critical, especially in high center of gravity applications like dump trucks and concrete mixers. Check periodically for wear
- Check bolsters for cracks/debonds
  - Replace if material is cut 1" length or 3/8" in depth
  - Replace if bond separation is >1/2" deep

The most common root causes of cracked or broken frame brackets:

- Vehicle is overloaded
- Worn transverse torque rods
- Frame bracket bolts/fasteners are loose
- Auxiliary spring is worn



### FAILURE ANALYSIS

A debond of a bolster spring is often a secondary failure and the location of a debond can help locate the source of the root cause.

LOCATION	POSSIBLE PRIMARY FAILURE POINT
Debond at top plate	Check torque rods for bushing failure
Debond at lower plate	Check bar pin end bushing for failure

# HENDRICKSON HAULMAAX

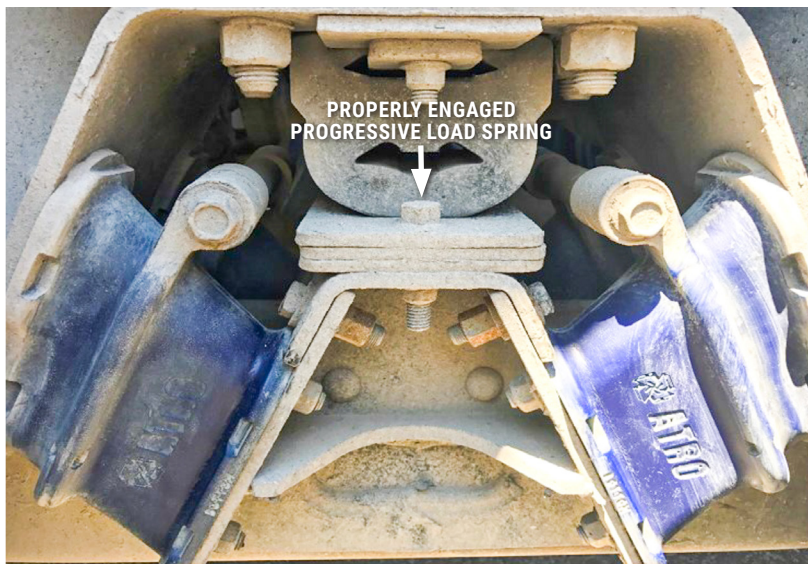

## Kits

A key element in an efficient repair is having all the key parts and components. The KT50-25002 or KT50-25003 are complete kits with hardware for bolster spring repairs. The EB50-21013, bar pin end bushing kit, contains all the necessary bolts, nuts, shim and washers. Look for detailed installation instructions by searching for EB50-21013 on [ATROBUSHING.COM](http://ATROBUSHING.COM).

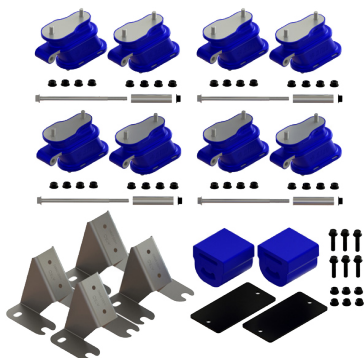

**KT50-25003**  
SUSPENSION KIT

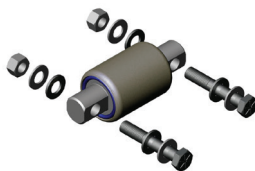

**EB50-21013**  
BAR PIN BUSHING KIT

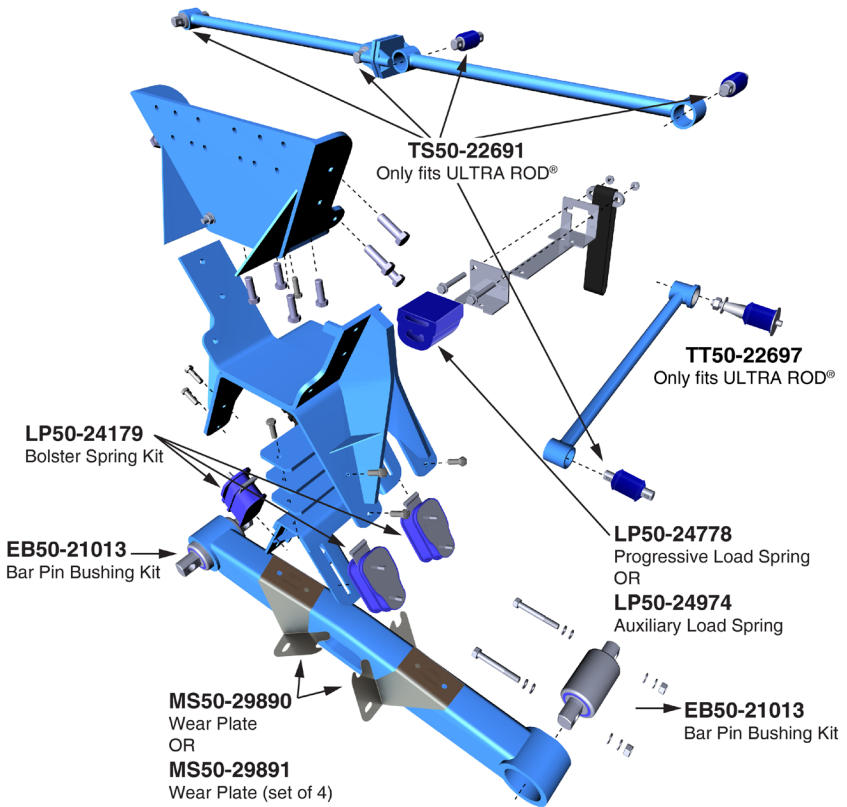

Scan QR Code to go to video:  
**ATRO Parts | Hendrickson HAULMAAX®**  
**Suspension**



# HENDRICKSON HN

This walking beam suspension features bar pin end bushings with no center bushings for the beams to pivot on. The traditional center bushing is replaced by two large bolster springs (four per vehicle).

## WEAR ITEMS

- The transverse rod is critical, especially in high center of gravity applications like dump trucks, concrete mixers. Check periodically for wear.
- Check bolsters for cracks/debonds
  - Replace if material is cut 3" length or 1" in depth
  - Replace if bond separation is >1 1/2" deep
- Auxiliary spring should be replaced if the spring itself measures less than 3" in height when the truck is unloaded.

## TECH TIP

The proper number of shims for the auxiliary spring can vary according to application and unladen tandem weight. Refer to ATRO Technical Bulletin TB001-012418 at [WWW.ATROBUSHING.COM](http://WWW.ATROBUSHING.COM) for details.

## FAILURE ANALYSIS

LOCATION	POSSIBLE PRIMARY FAILURE POINT
Debond at top plate	Check torque rods for bushing failure
Debond at lower plate	Check bar pin end bushing for failure

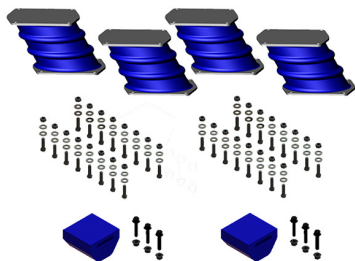

### KT50-25005

#### HN SUSPENSION KIT

Contains:

- (2) LP50-24000 (4 Bolsters)
- (2) LP50-24974 Load Spring Kit
- (32) Bolts, Grade 8
- (32) Locknuts
- (64) Flat Washers



Scan QR Code to go to video:  
**ATRO Parts | Hendrickson HN  
Suspension**

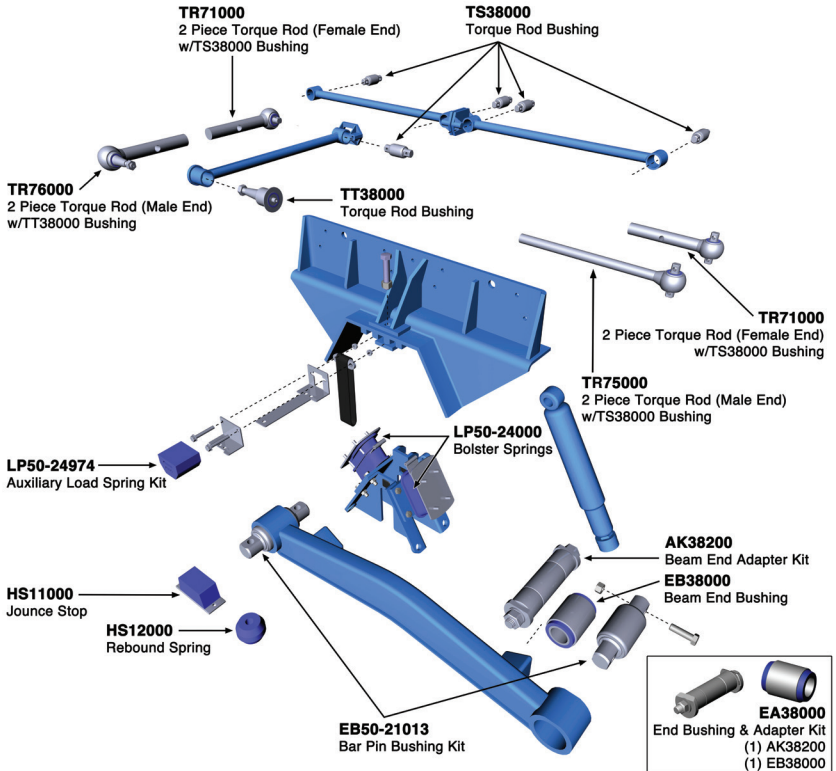
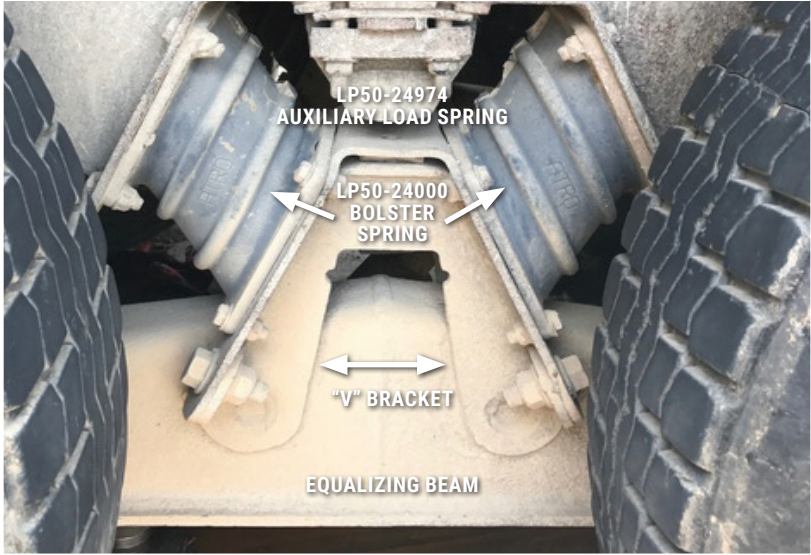



# HENDRICKSON PRIMAAX

This is a heavy-duty air suspension for vocational, severe-service and heavy-haul applications. It is approved for use by the OEM for crane, dump, heavy-haul, logging, mining, cement mixer, oil field, tanker trucks and waste haulers.

There are multiple versions of this suspension. The variations in design are usually found in the shape of the hangers, length/location of the shocks or unique air springs but the overall design idea is the same.

ATRO offers a full complement of bushings and torque rod options for Hendrickson's Primaax.

ATRO's pivot bushing, PB50-26648, utilizes a low friction intermediate sleeve to ease rotation and improve resistance to wear.

**Note:** The OEM's pivot bushing, 58648-000, is used in Primaax, MaxAir and Twisted Sister. Though ATRO offers a direct cross-reference with its PB50-26648, it is only for use in Hendrickson's family of Primaax suspensions.

- On ATRO's website, [WWW.ATROBUSHING.COM](http://WWW.ATROBUSHING.COM), PB50-26648 has a simple installation guideline located under Resources>Instruction Sheets



## WEAR ITEMS

- Frame hanger attachment area becomes oblong
  - Usually caused by loose pivot bolt fasteners or overloading
  - Check transverse torque rods for wear
- Torque rods
  - Longitudinal rods – bushing walks out of rod

## Check for Improper Alignment or Worn Bushings

- Transverse torque rods
  - Check for incorrect axle alignment, incorrect pinion angle, incorrect frame hole location or if axle bracket weld is off
  - Worn bushings

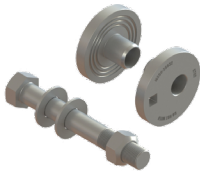

**HW50-26961**  
COLLAR/HARDWARE KIT



**PB50-26961**  
PIVOT BUSHING KIT



**PB50-26632**  
PIVOT BUSHING KIT

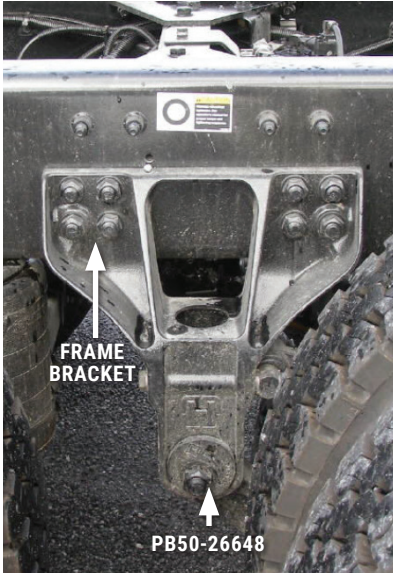

**PRIMAAX EX**

Standard Bracket  
8 1/2" - 10" Ride Height



**PRIMAAX EX**

Optional Bracket for  
12 1/2", 14 1/2", 15 1/2" Ride Height

- TR71000**  
2 Piece Torque Rod (Female End)  
w/TS38000 Bushing
- TR75000**  
2 Piece Torque Rod (Male End)  
w/TS38000 Bushing
- TR76000**  
2 Piece Torque Rod (Male End)  
w/TT38000 Bushing

- PL1146**
- TS38000**
- TS50-22691**
- TT50-22809**  
Torque Rod Bushing

**PB50-26648**  
Pivot Bushing

**MS50-26632**  
Eccentric Collar

**TH50-22692**  
**TS50-22210**  
**TS50-22691**  
Torque Rod Bushing

**MS50-26633**  
Concentric Collar

**TR50-49605**  
**TR50-49645**  
Torque Rod

**SU50-29383**  
"D" Pin Bushing

**Primaax EX®** - Enhanced U-Beam Assembly with integrated end cap  
**Primaax®** - Support Beam plus detachable end cap

# HENDRICKSON RS

This walking beam suspension is most often found on cement mixer trucks. The OEM rubber load springs are usually found to have taken significant compression set due to their inability to withstand the acid wash used to clean lime off the suspension. The acid attacks and weakens the rubber, compromising its ability to sustain the load. ATRO polyurethane is impervious to chemical attack.

- ATRO's RS load pads are made of a proprietary low rebound (no-bounce) material to absorb shock and limit its transfer to the frame. To accomplish this with rubber, the OEM traditionally offers two different part numbers of varying hardness for specific applications. ATRO's single part number will perform reliably in any application.



## TECH TIP

- ATRO center bushings require thrust washers
- ATRO bushings have free-rotation design
  - Eases installation
  - Automatically zeros out to ride height



## WEAR ITEMS

- Rubber springs – due to chemical attack which can cause dry rot and compression set
- Walking beam bushings – both bar pin end and center bushings
- Torque rod/bushings – check all, particularly transverse rods

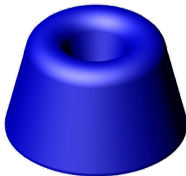

**HC10000**  
CENTER LOAD  
CUSHION

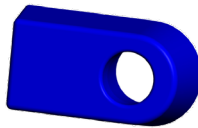

**HC20000**  
LOAD CUSHION

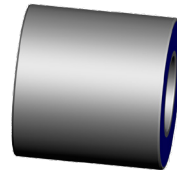

**HV38000**  
VERTICAL BUSHING



Scan QR Code to go to video:  
**ATRO Parts | Hendrickson RS**  
**Suspension**

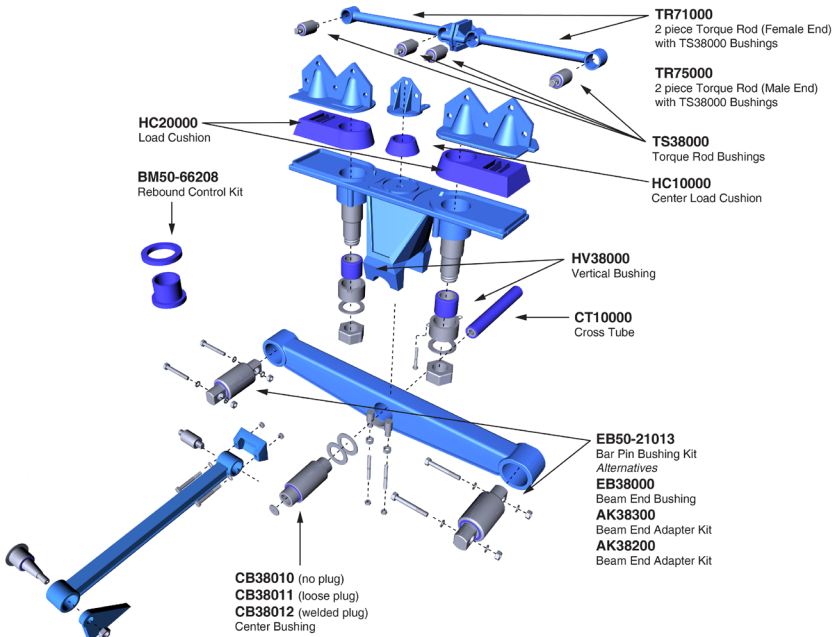
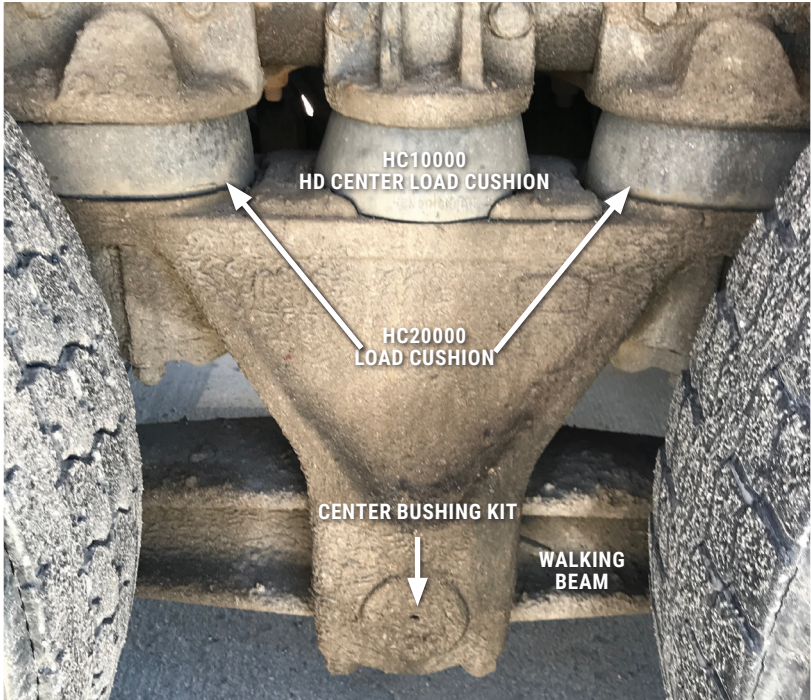

# HENDRICKSON RT

This steel leaf spring, walking beam suspension has been an industry standard for vocational trucks for over 85 years. The steel springs are designed to provide a consistent spring rate while the walking beams act to distribute the load evenly between both axles. It can be found on a wide variety of vocational truck applications including fire trucks, mining vehicles, dump trucks, cement mixers, waste haulers and building/material supply.



## TECH TIP

- ATRO center bushings require thrust washers
- ATRO bushings have free-rotation design
  - Eases installation
  - Automatically zeros out to ride height



## WEAR ITEMS

- Walking beam bushings – both bar pin end and centers bushings
- Torque rod/bushings – check all, particularly transverse rod

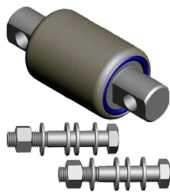

**EB50-21013**  
BAR PIN BUSHING  
KIT

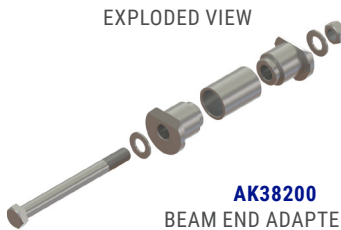

**AK38200**  
BEAM END ADAPTER KIT  
(FLUSH BOLT)



ASSEMBLED VIEW

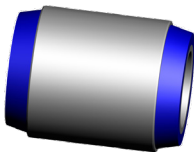

**EB38000**  
BEAM END  
BUSHING

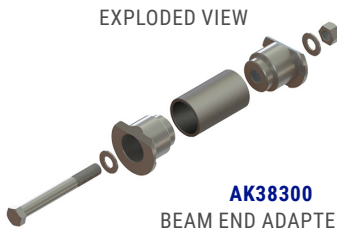

**AK38300**  
BEAM END ADAPTER KIT  
(RECESSED BOLT)



ASSEMBLED VIEW



Scan QR Code to go to video:  
**ATRO Parts | Hendrickson RT**  
**Suspension**



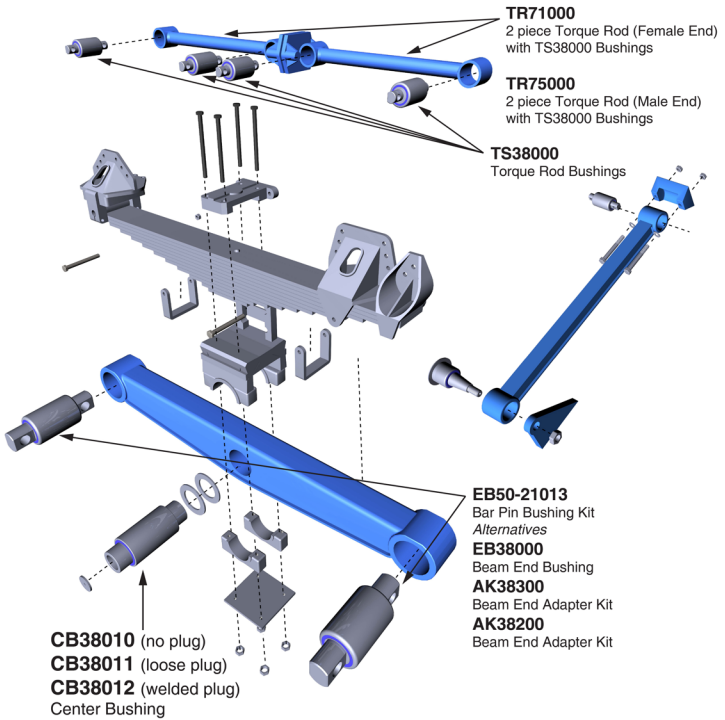

# INTERNATIONAL CORPORATE AIR/IROS (INTERNATIONAL RIDE-OPTIMIZED SUSPENSION)

This suspension is similar in concept to the Freightliner FAS II and Peterbilt's New Low Air Leaf. The biggest maintenance concern is the bonded bushing in the spring eye. Commonly, it will open up and the bushing can walk out.

- With a bonded OEM-style rubber bushing, the entire bushing can be forced to spin within the spring eye causing it to expand. Bonded rubber bushings attempt to combat this with an inboard flanged end encased in a ring with detents for gripping the edge of the spring's eye.

## ATRO Spring Pin Solution (PB46-26268; UB20500-OS)

- Rotating pin design with flanged outer sleeve limits travel
- The revolving inner pin eliminates bushing wind-up and prevents entire bushing spinning
- UB20500-OS, an over-sized version (+.060"), is available if the rubber bushing has opened up the spring eye slightly. The spring must still meet specifications. If not, the spring must be replaced, not rebushed.

## ATRO Torque Rod

- The OEM offers multiple torque rod options on this suspension. That standard rod can be replaced by ATRO's TR55-418C1 – other OEM options include non-rebushable rods, those with 2 17/32" outer diameters (rebushed by ATRO's TS34000), or even tubular rods with jam bushings rebushed by ATRO's TS50-22691 or PL1146.
- Inner pin in both the standard rod (TR55-418C1) and the small eye rod (TR55-428C1) rotates for installation – enabling easy alignment with bolt holes in the straddle bushings configuration.
- Rebushable (both the standard rod and the small eye rod.)



Scan QR Code to go to video:  
**ATRO Parts | International Corporate  
Air/IROS Suspension**



**TR55-428C1**  
 Torque Rod, Small Eye  
 with TS00-22500 Bushings  
 -OR-  
**TR55-418C1**  
 Torque Rod  
 with TS38000 Bushings

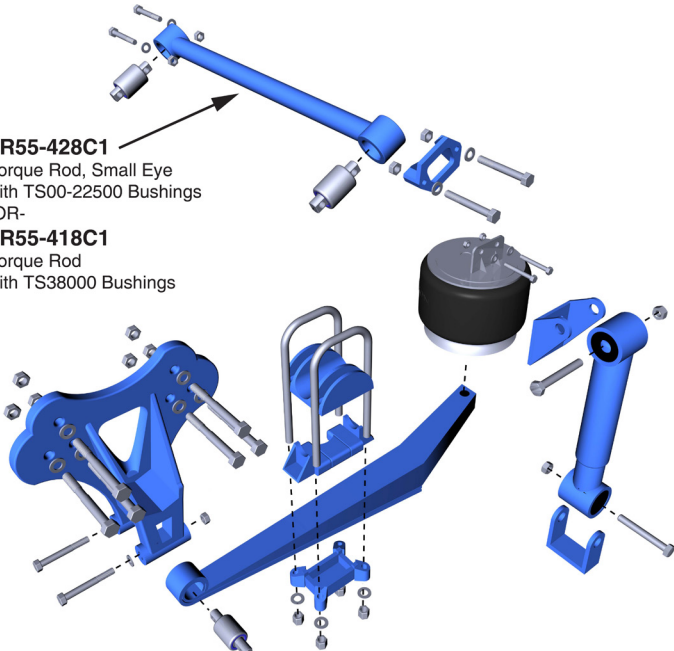

**PB46-26268\***  
**UB20500-OS**  
 Pivot Bushing

# KENWORTH AIRGLIDE 100

This was the first in Kenworth's Airglide series. It features sway bars, torque rods and eight air bags. There are four torque rods— two transverse, two radial track rods. The radial rods (running the length of the vehicle) can be either 24" (TR59-41375) for 52" axle spread or 25" (TR59-41150) for 54" axle spread. The two transverse rods on both are TR59-41376.

The OEM rubber sway bar wrap bushing does not have tabs, but when the bushing is compressed in the housing, the rubber bulges out effectively forming side tabs. ATRO pre-molds those side tabs into its PL1008; the PL1184 is molded without tabs. The ends of the sway bar are bushed with ATRO's freely rotating TS38000.

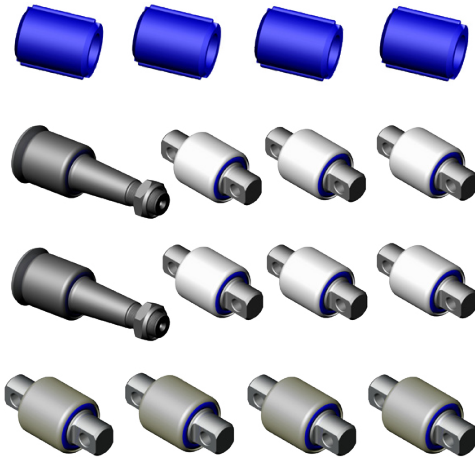

## **AG10000** AIRGLIDE 100 REBUILD BUSHING KIT

Contains:  
(4) PL1008  
(10) TS38000  
(2) TT38000



Scan QR Code to go to video:  
**ATRO Parts | Kenworth AirGlide 100**  
**Suspension**



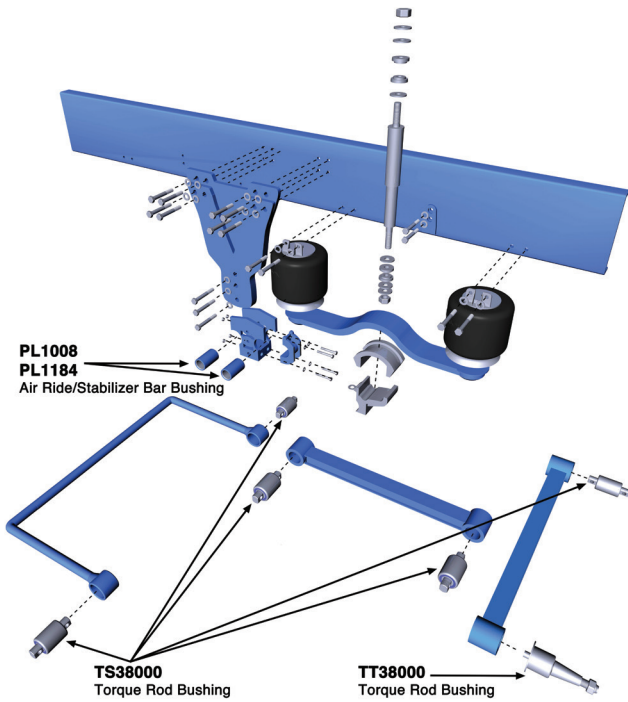

# KENWORTH AIRGLIDE 200/400

The Kenworth AG200 was the second in the Airglide series but had considerable problems with the wishbone arm assembly. The solution to this problem is an upgrade to the AirGlide 400 which replaces the wishbone arm assembly with a redesigned parabolic sway bar.



## TECH TIP

- Four upper torque rods are uniquely positioned in this suspension. This suspension combines the transverse and longitudinal torque rods into a dual rod, V-configuration with the torque rods mounted vertically.
- ATRO's TS59-22400 bushing is a high-articulation bushing designed to withstand the conical motion required. It is the only ATRO torque rod bushing approved for use in OEM aluminum rods.
- ATRO's replacement torque rods feature:
  - Stronger, more durable steel rod than aluminum rod
  - Forged steel rod eyes
  - Heavy-walled steel shaft

## Sway Bar Kits

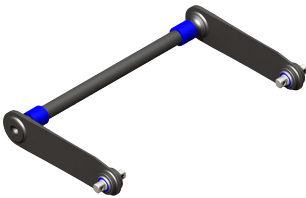

### INDIVIDUAL SWAY BAR ASSEMBLIES

SW59-29000 (52" Axle Spacing)  
SW59-29001 (54" Axle Spacing)

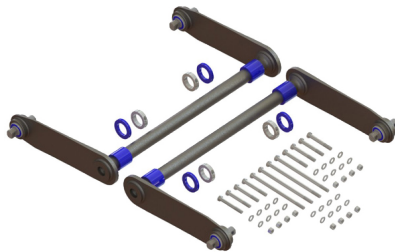

### SWAY BAR COMPLETE CONVERSION KIT

SW59-29000-KIT (52" Axle Spacing)  
SW59-29001-KIT (54" Axle Spacing)



Scan QR Code to go to video:  
**ATRO Parts | Kenworth AirGlide 200/400  
Suspension**

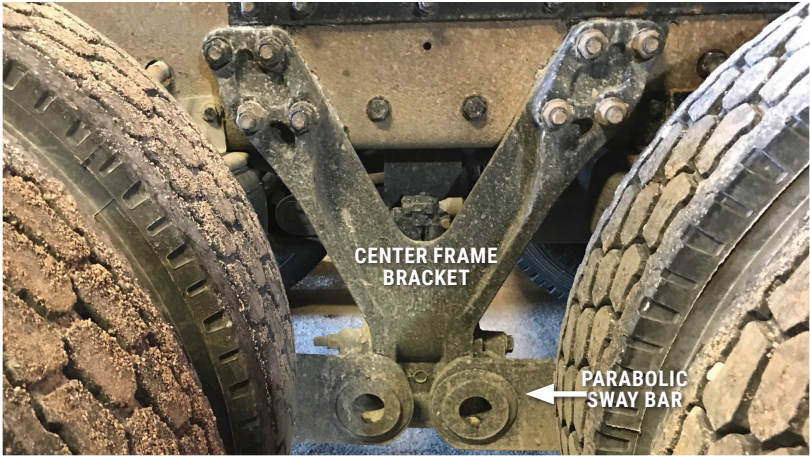

**CENTER FRAME BRACKET**

**PARABOLIC SWAY BAR**



**TO FIND THE CORRECT KIT FOR YOUR AXLE SPACING, MEASURE CENTER OF HUB TO CENTER OF HUB**

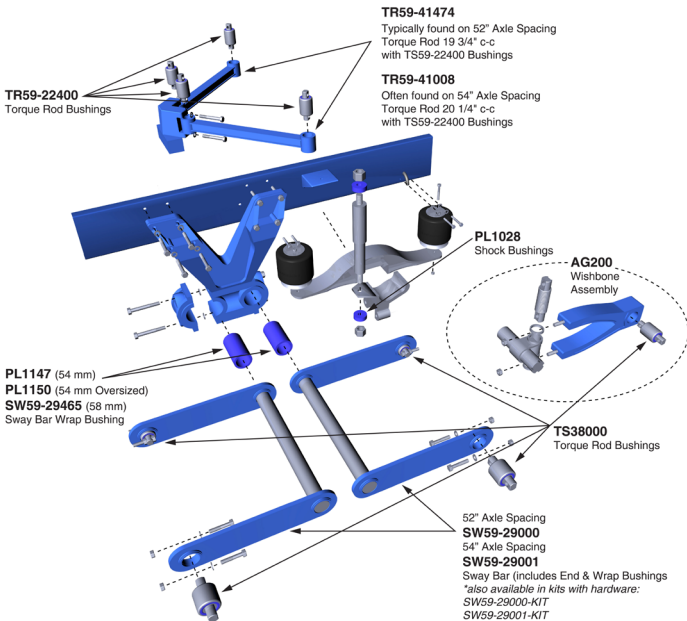

# KENWORTH AIRGLIDE 380/ PETERBILT FLEXAIR

This popular on-highway air suspension is easily identifiable and available on Kenworth and Peterbilt trucks. It features an aluminum beam with a C-shaped taper leaf spring in the front and an air spring behind the axle shackle.

- Kenworth brands this suspension as an AirGlide 380; on a Peterbilt, this same suspension is named FlexAir
- Key identifying feature: the C-shaped spring link
- ATRO offers the spring link bushings SU00-29001 (straddle) and the SU00-29002 (hollow mount)
- The suspension contains six torque rods – two transverse, two lower front, two lower rear. The front rods (TR00-41001) are nearly an inch shorter than the rear rods (TR00-41600) and both front and rear rods have a straddle-hollow mount configuration. The two transverse rods (both are TR00-41009) have a straddle-straddle configuration.
- All replacement torque rods on this suspension have the smaller 2" rod eye with ATRO's TS00-22500 (straddle) and TH00-22500 (hollow). These bushings have outer sleeves, the pins rotate, and the rods are rebushable with ATRO bushings only.
- To rebush the OEM rod which has 1 7/8" rod eyes, use ATRO's PL1146 (straddle, no rims, easy install) or TS50-22691 (straddle, retaining rims) and TH50-22692 (hollow). These bushings do not have rotating inner pin/sleeve.



## WEAR ITEMS

- All torque rods, particularly transverse torque rods



Scan QR Code to go to video:  
**ATRO Parts | Kenworth AirGlide 380 |  
Peterbilt Flex Air Suspension**



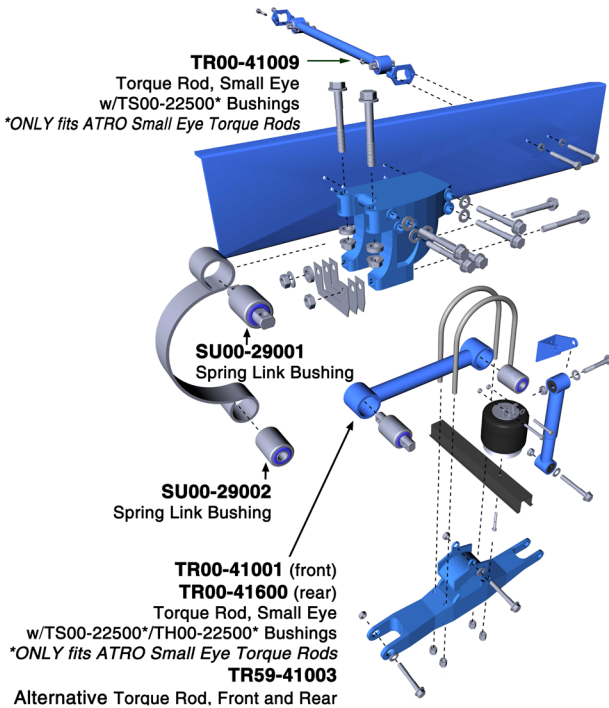
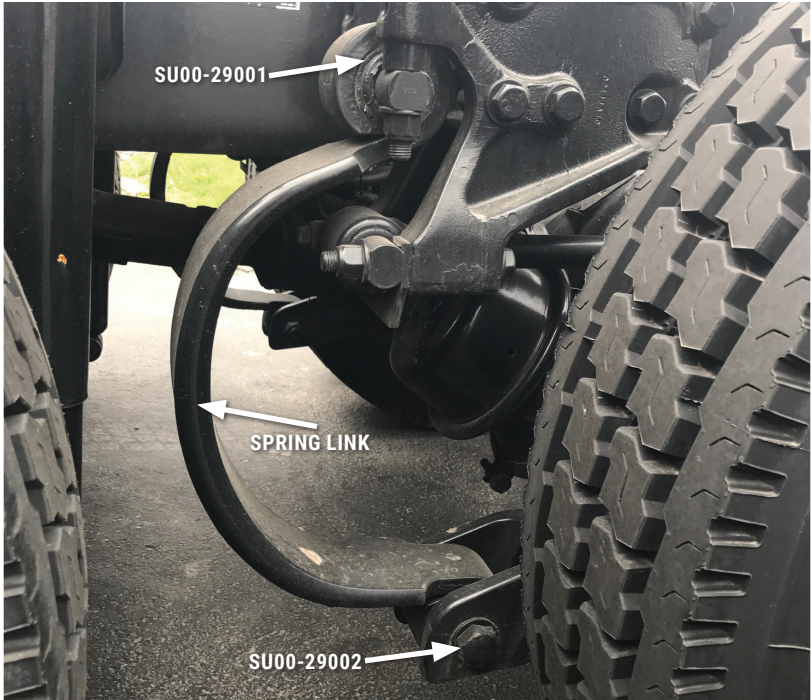



# MACK CAMELBACK

This progressive spring suspension for off-road and severe-service vocational applications has been around since 1948. The design with its large inverted spring and bouncy rubber load pads (aka elephant's feet) provided ATRO an opportunity to dramatically improve the ride quality for which this suspension is notorious.

## ATRO Load Pads

- Low rebound – no bounce
- Chemically resistant
- Do not mix ATRO with other manufacturers

## ATRO Benefits

- Specially formulated for this application, ATRO's proprietary polyurethane takes the bounce out and acts to absorb shock. The significantly improved ride is immediately noticeable.
- ATRO reduces cab damage and T-leaf breakage, too
- Extended life load pad



## WEAR ITEMS

- Load pads
- Trunnion bushings
- Torque rod/torque rod bushings

## Insulator Kits

**SK62-50340**  
INSULATOR KIT  
W/HARDWARE

Contains:

- (4) MA36000
- (4) MA36500
- (4) 7/8"-9UNC 4" Bolts
- (12) 7/8"-14UNF 6" Bolts
- (12) Locknuts
- (16) Flat Washers

**SK62-50380**  
INSULATOR KIT  
W/HARDWARE

Contains:

- (4) MA36000
- (4) MA37000
- (4) 7/8"-9UNC 4" Bolts
- (12) 7/8"-14UNF 6" Bolts
- (12) Locknuts
- (16) Flat Washers

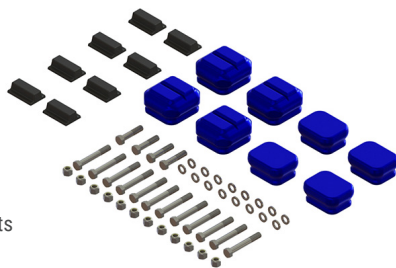

**ALSO AVAILABLE IN SEVERE DUTY**  
**SK62-50340-SD & SK62-50380-SD**



Scan QR Code to go to video:  
**ATRO Parts | Mack Camelback**  
**Suspension**

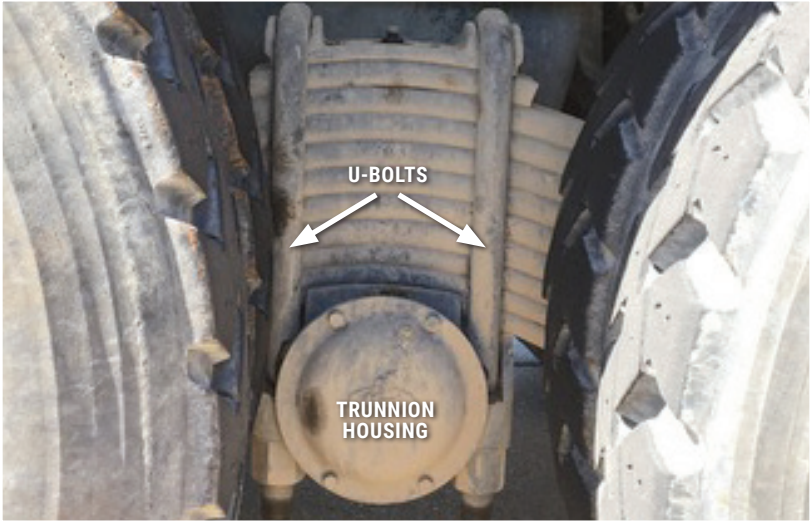

- TR71000**  
2 Piece Torque Rod (Female End)  
w/TS38000 Bushing
- TR75000**  
2 Piece Torque Rod (Male End)  
w/TS38000 Bushing
- TR77000**  
2 Piece Torque Rod (Male End)  
w/TM38000 Bushing

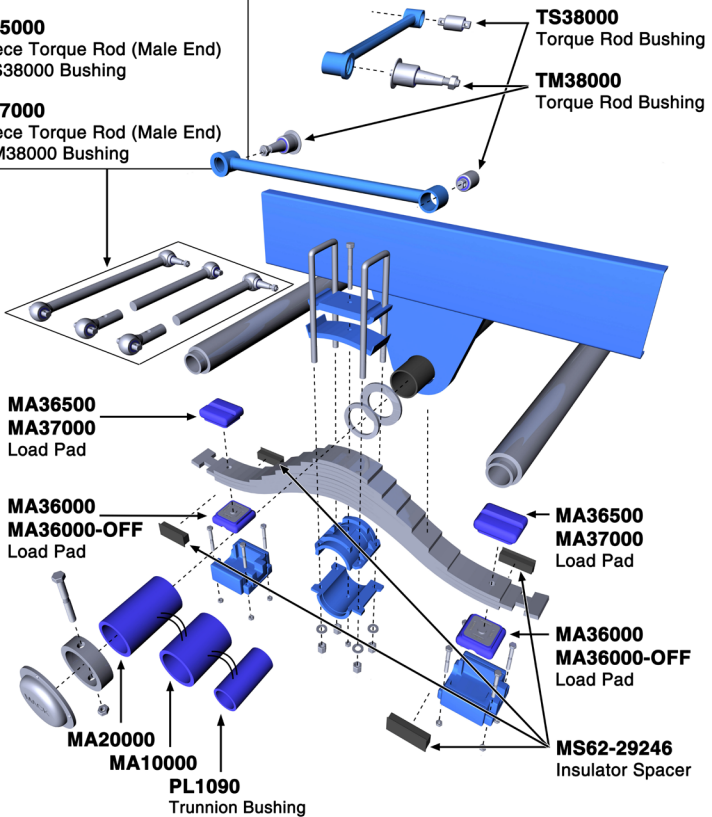

# MACK AL40

This air suspension is a Hendrickson HAS designed for a Mack chassis with 40,000 lb capacity. It features a Z-spring main support with large air springs atop a cross channel. The Mack AL is used on CXN, CHN, CX, CH, CV, CT, CL and RD model chassis equipped with either Mack, Meritor or Eaton rear axles.

This suspension is optimally designed for on-road, line-haul applications (tankers, grocery operations, beverage trucks, car carriers, vans or flatbeds) and situations where ride quality, loaded and unloaded, is important.

ATRO offers replacements for the torque rods, torque rod bushings and the slipper wear pads (with or without hardware):

## Torque Rods

- Transverse rod
  - TR62-41183 – 18 ¼" c-c with standard bushings, TS38000/TM38000; rotating pin for easy installation, chemically resistant polyurethane (replaces OEM# 25168854)
- Longitudinal rods
  - TR62-417M1 – 14.41" c-c length, small eye rod, TS00-22500 in each end; rotating pin, chemically resistant polyurethane (OEM# 25112948)
  - TR50-41102 – 14 3/8" c-c, standard eye rod option, TS38000 (2 ¾" outer diameter), rotating pin, chemically resistant polyurethane
  - TR50-45950 – adjustable, small eye rod, TS00-22500 in each end; rotating pin, chemically resistant polyurethane (OEM# 25168255)
  - Both the TR62-417M1 and TR50-45950 are replacing OEM rods that have rubber jam-style bushings with 1 7/8" outer diameters. ATRO's TS00-22500 only fit ATRO's rods – the 2" outer diameter makes room for an outer sleeve. This outer sleeve achieves a press-fit into the rod and allows for inner pin rotation.
  - To rebush OEM rod with ATRO polyurethane, use PL1146 (no outer sleeve, no pin rotation)

## Wear Pads - Chemical/Abrasion Resistant Polyurethane

- Wear pad kits
  - WP50-29004 – WP50-29929 pad with retaining clips and tapping screws (old style)
  - WP50-29005 – WP50-29929 pad with lock pins (current style)
- Wear pad only, no hardware
  - WP50-29929



**TORQUE ROD, STRADDLE/TAPER**  
TR62-41183



**TORQUE ROD, SMALL EYE**  
TR62-417M1



**TORQUE ROD, ADJUSTABLE**  
TR50-45950 – *Driver's Side*



**TORQUE ROD, STANDARD**  
TR50-41102 – *Passengers Side*

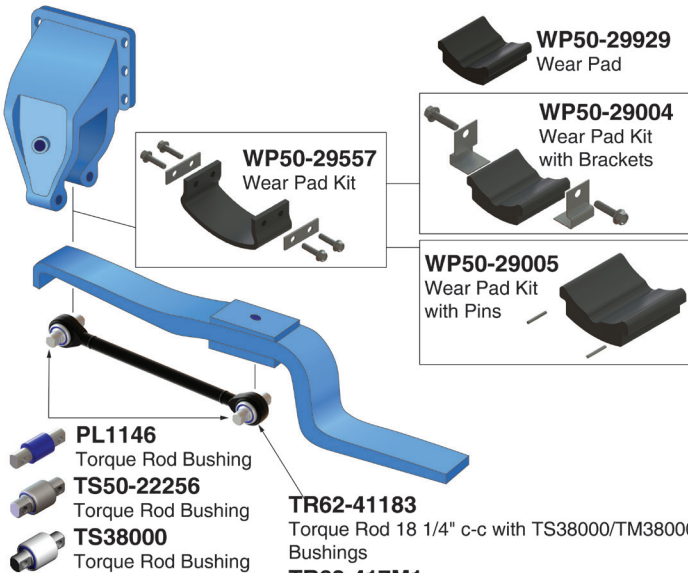

- PL1146**  
Torque Rod Bushing
- TS50-22256**  
Torque Rod Bushing
- TS38000**  
Torque Rod Bushing

**TR62-41183**  
Torque Rod 18 1/4" c-c with TS38000/TM38000 Bushings

**TR62-417M1**  
Torque Rod, Small Eye 14.41" c-c

**TR50-45950**  
Torque Rod, Adjustable 14.31" c-c

**TR50-41102**  
Torque Rod 14 3/8" c-c with T38000 Bushings

# NEWAY AD

The NEWAY AD Drive Axle Air-Ride is an off-road severe duty drive axle suspension and is designed for heavy haul trucks in the tough terrains. The AD often used in industries like logging, construction, cement, mining, fire trucks and other heavy haul applications. It is often seen in single (AD123, AD126, AD130), tandem (AD246, AD252, AD260) and tri-axle (AD369, AD378, AD390) configurations with capacities from 23,000 to 30,000 pounds. The specific model is easily identified with a few quick measurements.

## Identifying Features

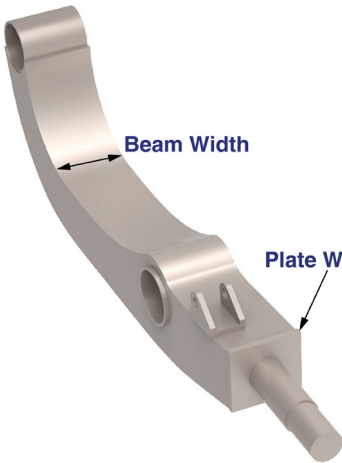
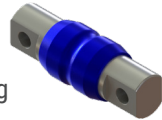
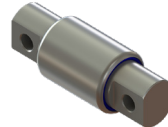

	PLATE WIDTH	BEAM WIDTH
AD123	1/2"	5.25"
AD126	1"	5.25"
AD130	1"	6.00"

The AD123 uses a jam-style axle bar pin bushing



The AD126 uses a bar pin style bushing with a metal outer sleeve





# NEWAY AD123

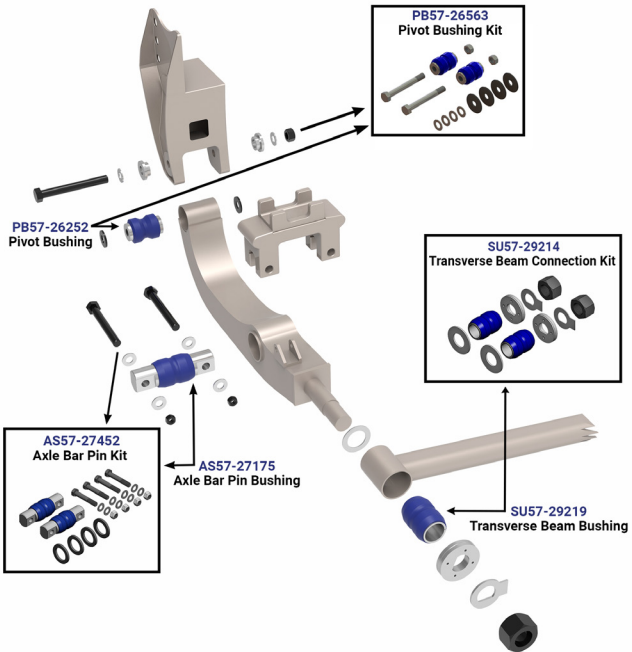

# NEWAY AD126

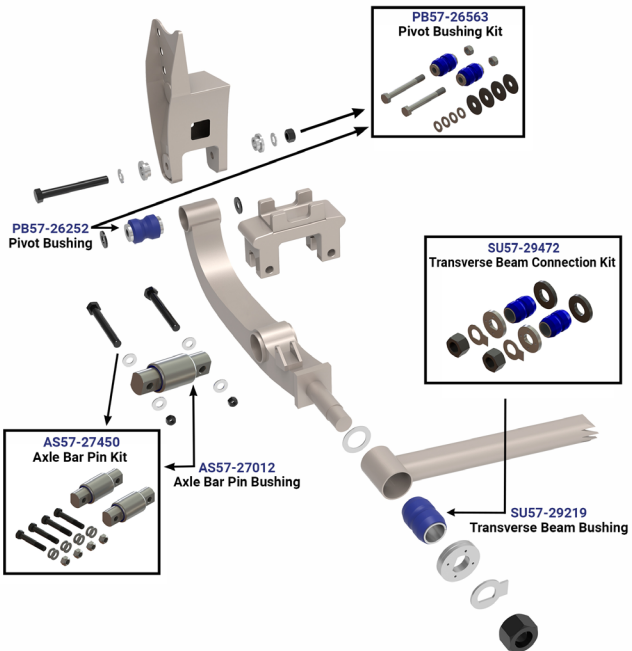

# NEWAY ADZ

This suspension is a heavy-duty on- and off-road drive axle air ride suspension that is 220-lbs lighter per axle than its predecessor, Neway AD. The upper control arms use the V-rod design with vertical end bushings. The lower control assembly has an integrated one-piece design to increase roll stability. In the front, it features an easy alignment pivot connection with a rotating pivot collar for axle realignment while the rear of the assembly uses a solid connection between the cast trailing arm and transverse beam.

Heavy applications are typically front/rear mixers, construction, fire, aggregate dumps, logging, mining, oil & gas. Over-the-road applications include refuse, municipal, heavy haul and utility trucks.

ATRO offers polyurethane replacements for beam and center bushings, a V-rod assembly, and/or straddle and hollow mount apex bushings separately or as part of a rebush kit.

## V-Rod

- V-Rod Assembly – TR57-44992 is a V-rod with ATRO's polyurethane bushings pre-installed (TS59-22400, vertical straddle and TH57-22264, hollow apex.)
- V-Rod Rebush kit, TR57-44645 – with the TH57-22264 apex bushing and two TS59-22400 vertical straddle bushings with all attaching hardware included. (OEM # SRK-645)
- Replacement bushings – TS59-22400 and TH57-22264 available separately, without hardware.

## Lower Control Arm

- Beam end bushing kit, PB57-26643 – with two pivot bushings (PB57-26279) and attaching hardware
- Axle seat bushing kit, AS57-27644 – with two axle seat bushings (AS57-27267) and attaching hardware
- Replacement bushings – PB57-26279 and AS57-27267 available separately, without hardware



### WEAR ITEMS

- V-rod bushings, particularly the apex bushing which the OEM does not sell separately; available as ATRO's TH57-22264
- Beam end bushing, OEM# 90008266; replace with ATRO's PB57-26279

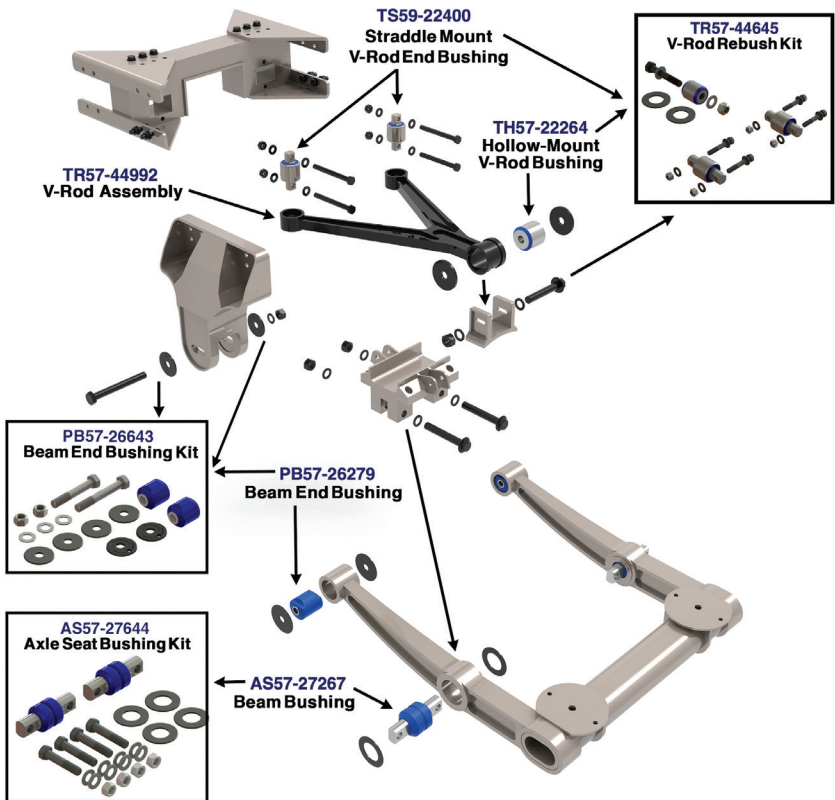

# PETERBILT AIR LEAF

This air suspension has a maximum capacity rating of 40,000 pounds. This suspension, like the Low Mount Air Leaf, does not have lower radius rods like those found on the Air Trac. The air bags are supported on a paddle.

The eye casting that is bolted on the spring houses the pivot bushing (ATRO's PB75-29674: OEM#03-04059)

- PB75-29674 is a spring eye bushing service kit that has bushings, sleeve, washers and hardware. The polyurethane components within this kit are PL1076 and PL1075 (2 per kit) and are also available separately. (PB75-29674 is ½" longer than the original design Low Mount Air Leaf version, PB75-29101.)
- Tech Guidelines bulletin TG103009 outlines recommended installation sequence for PB75-29674 and is available at [www.ATRObushing.com](http://www.ATRObushing.com) under the "Technical Bulletins".

## ATRO's Torque Rod (TR75-41059 - OEM# 03-04059/C65-6013)

- Rebusable (OEM standard is non-rebusable; rebusable OEM options are available)
- Rotating pin for easy installation
- Chemically resistant proprietary polyurethane
- Heavy-duty bushing – the OEM standard bushing is a smaller outer diameter. The ATRO solution is a more robust bushing (TS38000, 2 ¾" OD), there is no clearance issue with the change

## Rebushing an OEM Rod

- Use ATRO's TS34000 (2 17/32" OD)

MANUFACTURER	ROD	BUSHING DIMENSION	REBUSABLE	ROTATING
ATRO#TR75-41059	1 1/4" OD	TS38000 (2 3/4")	Yes	Yes
OEM#03-04059	1 1/8" OD	TS34000 (2 17/32")	Varies	No



### WEAR ITEM

- Spring eye pivot bushing
- Torque rod/torque rod bushings



Scan QR Code to go to video:  
**ATRO Parts | Peterbilt Air Leaf  
Suspension**



**PB75-29674**  
Air Leaf Bushing Kit

Assembled

Exploded

Eye Casting Bushing & Bolt

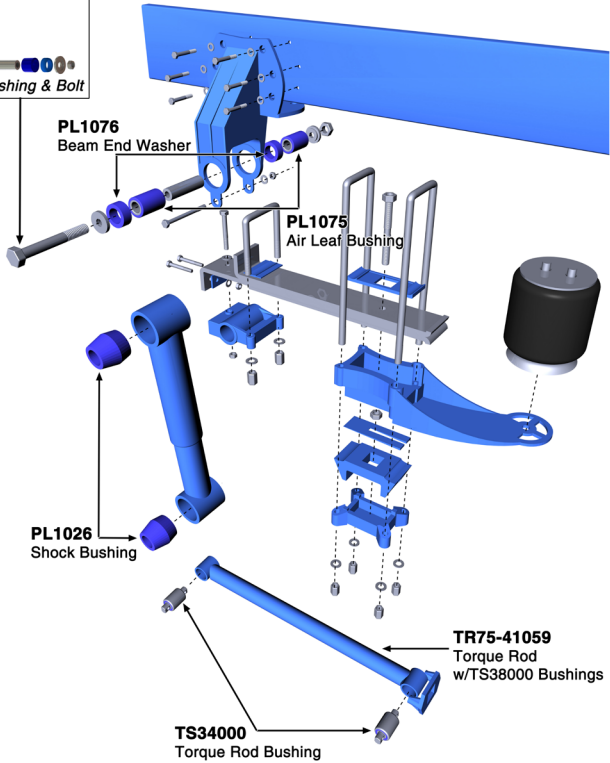



# PETERBILT AIR TRAC

This air suspension has a maximum capacity rating of 46,000 pounds. It features lower radius rods that strengthen and stabilize the suspension but tend to cause a rougher ride quality than the Air Leaf or Low Mount Air Leaf.

## ATRO's Transverse Rod (TR75-41059, OEM# 03-04059)

- Rebushable and rotating-pin for easy installation
- Heavy-duty bushing (OEM standard bushing has smaller O.D.)
- If rebushing ATRO's TR75-41059, use ATRO's TS38000
- If rebushing OEM/aftermarket rods, use ATRO's TS34000

## ATRO's Torque Rods for Lower Rod Replacement

- Rebushable and a rotating-pin for easy installation
- The lower rods come in two versions –
  1. ATRO's TR75-41119 is a direct OEM replacement – both use the larger straddle bushing (TS38000)
  2. ATRO's TR75-41327 option is also a direct replacement to the OEM offering. Note: the bushings within the same rod differ. The axle bracket end has a 3/4" bolt but the frame end has a 5/8" bolt. ATRO's rod, TR75-41327, has a TS38000 in one end and a TS38750 in the other.

ATRO also offers the spring roller, SU75-29623 or the complete spring roller kit, SU75-29624. The ATRO kit includes the polyurethane and steel rollers plus the bolt, nut and washer.



### WEAR ITEMS

- Torque rod/torque rod bushings
- Spring roller



Scan QR Code to go to video:  
**ATRO Parts | Peterbilt AIR TRAC**  
**Suspension**



HANGER

SPRING

TORQUE ROD

**Torque Rods**

**TR75-41059** (22-7/8" c-c)  
w/TS38000 Bushings  
- or -

**Torque Rods-Small Eye**  
**TR00-41009**  
w/TS00-22500 Bushings

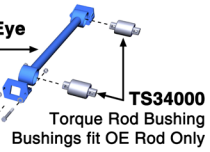

**TS34000**  
Torque Rod Bushing  
Bushings fit OE Rod Only

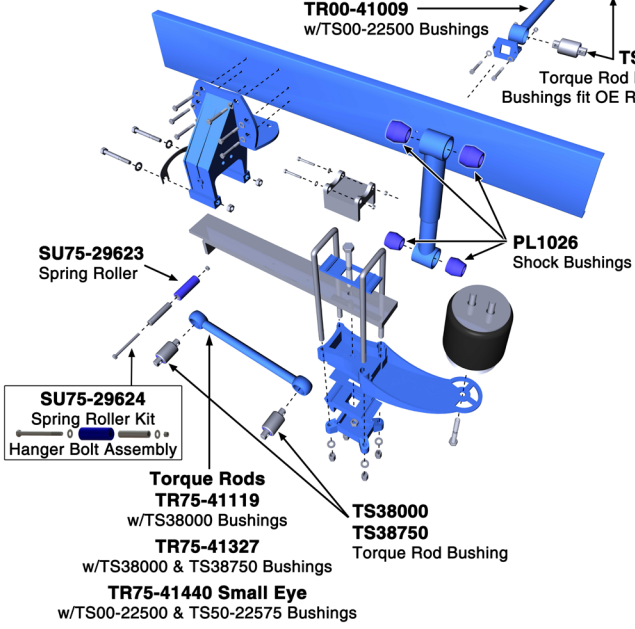

**SU75-29623**  
Spring Roller

**PL1026**  
Shock Bushings

**SU75-29624**  
Spring Roller Kit  
Hanger Bolt Assembly

**Torque Rods**  
**TR75-41119**  
w/TS38000 Bushings

**TS38000**  
**TS38750**  
Torque Rod Bushing

**TR75-41327**  
w/TS38000 & TS38750 Bushings

**TR75-41440 Small Eye**  
w/TS00-22500 & TS50-22575 Bushings

# PETERBILT LOW AIR LEAF

This air suspension was used into the 2003 model year and has with a maximum capacity rating of 40,000 pounds. Like the Air Leaf, it does not have lower radius rods like those found on the Air Trac and tends to have a smoother ride than both the Air Leaf and Air Trac. The air bags are supported on the Z-spring assembly; no paddle.

A pivot bushing (ATRO's PB75-29101, OEM# 03AL2) is housed in an eye casting that is bolted to the spring.

- PB75-29101 is a spring eye bushing service kit that has bushings, sleeve, washers and hardware. The polyurethane components within this kit are PL1076 and PL1189 (two per kit) and are also available separately.
- Tech Guidelines bulletin TG103009 outlines recommended installation sequence for PB75-29101 and is available at [www.ATRObushing.com](http://www.ATRObushing.com) under "Technical Bulletins".

## ATRO's Torque Rod (TR75-41108, OEM# 03-05108)

- Rebushable (OEM standard is non-rebushable)
- Rotating-pin for easy installation
- Heavy-duty bushing (OEM standard bushing has a small O.D.)

MANUFACTURER	ROD	BUSHING DIMENSION	REBUSHABLE	ROTATING
ATRO#TR75-41108	1 1/4" O.D.	TS38000 (2 3/4")	Yes	Yes
OEM#03-05108	1 1/8" O.D.	(2 17/32")	No	No

### WEAR ITEMS

- Spring eye pivot bushing
- Torque rod/torque rod bushings



Scan QR Code to go to video:  
**ATRO Parts | Peterbilt Low Mount  
Air Leaf Suspension**

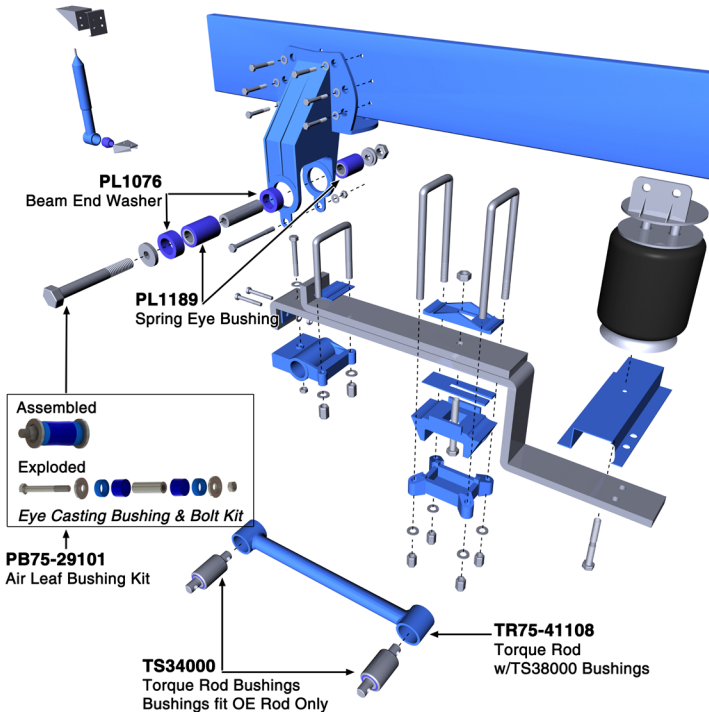
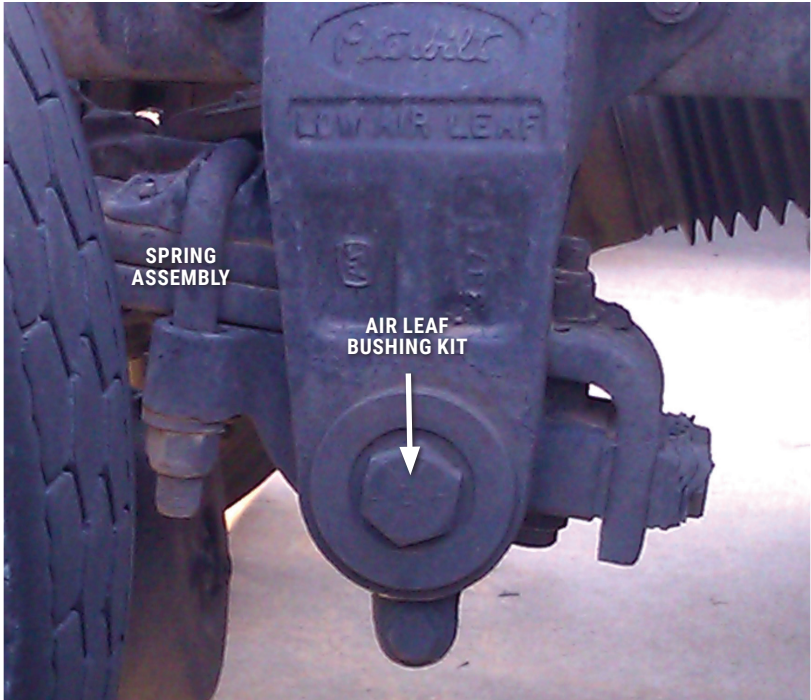

# PETERBILT NEW LOW AIR LEAF

Also known as the Kenworth AG400L, this air suspension became standard during the 2003 model year and reduced its weight 325 lbs when compared to its predecessor, Peterbilt's Low Air Leaf. It has considerably fewer parts, a higher weight rating (40k), and improved ground clearance. It is approved for use in belly-dumps and when lower fifth-wheel heights are necessary (high-cube van, reefer, bulk-haul, car carriers and high center-of-gravity loads.)

This suspension is similar in concept and design to the Freightliner FAS II and the International Corporate Air/IROS. The biggest maintenance concern is the bonded bushings; the spring eye opens up and the bushing can walk out.

With a bonded OEM-style rubber bushing, the pin is not allowed to rotate, so the entire bushing can be forced to spin within the eye of the spring thus leading to the wallowed out spring eye. Bonded rubber bushings attempt to combat this with an inboard flanged outer sleeve encased in a ring with detents for "gripping" the edge of the spring's eye.

## ATRO Spring Pin Solution (PB46-26268; UB20500-OS)

- Rotating pin design with flanged outer sleeve limits travel
- The revolving inner pin eliminates bushing wind-up and prevent entire bushing spinning
- UB20500-OS, an over-sized version (+.060"), is available if the rubber bushing has opened up the spring eye slightly. The spring must still meet specifications. If not, the spring must be replaced, not rebushed.

## ATRO Torque Rod

- Uses ATRO torque rod TR00-41009 (OEM# C65-6002.) This is a small-eyed rod with TS00-22500 in each end. The bushing in these rods will not fit OEM or other aftermarket rods. To rebush the OEM or other aftermarket torque rod, use ATRO's PL1146 (no rim and doesn't rotate) or TS50-22691 (retaining rims and doesn't rotate)
- ATRO's torque rod is rebushable (TS00-22500 bushing)



Scan QR Code to go to video:  
**ATRO Parts | Peterbilt New Low Air Leaf**  
**| Kenworth AG400L Suspension**



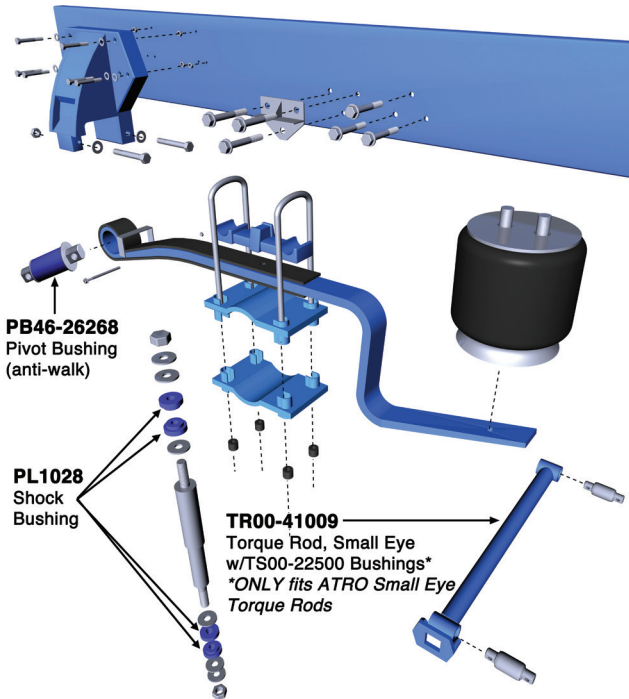
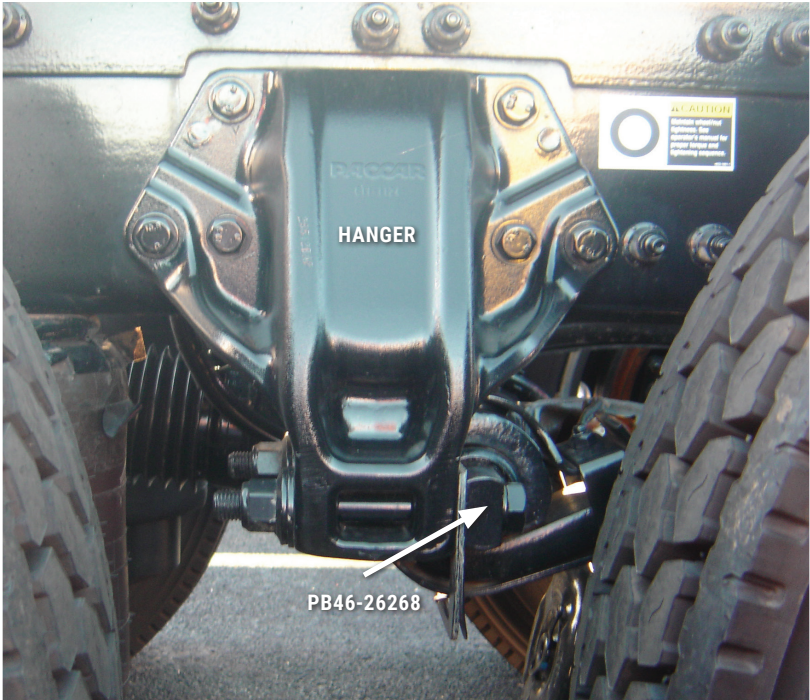

# VOLVO CORPORATE AIR RIDE

The Volvo Optimized Air Suspension (OAS) is the standard Volvo rear air suspension used on most Volvo applications in single and tandem axle configurations. The OAS suspension received updates after the 1998 and 2005 model years. This suspension is also known as the Mack Maxlite EZ.

**2006+**

**1999-2006**

**Before 1999**



**2006+**

**SU96-29083**  
Wear Pad, Spring

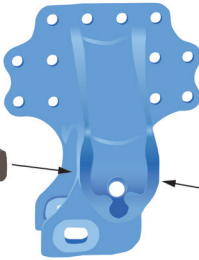
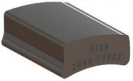

**SU96-29890**  
Spring Roller

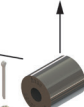

**SU96-29891**  
Spring Roller  
Assembly



**SP96-29479**  
Spring Roller  
Assembly

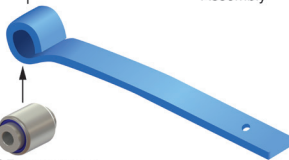

**1999-2006**

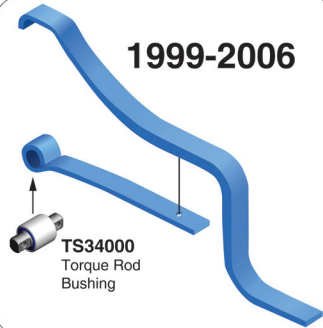

**TS34000**  
Torque Rod  
Bushing



**before  
1999**

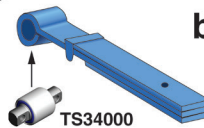

**TS34000**  
Torque Rod  
Bushing



# LEARN MORE ONLINE

Learn about suspensions  
at [ATROBUSHING.COM](http://ATROBUSHING.COM)

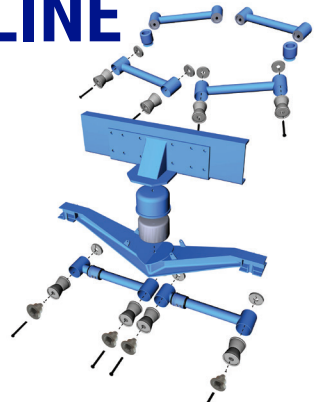

- Product Information
- Installation Instructions
- Technical Bulletins

Scan the QR Code to go  
to [Atrobushing.com](http://Atrobushing.com)

## STEER KING™

# by ATRO

### PREMIUM NO-REAM KING PIN REPAIR KITS



Shop-Ready  
Box Prevents  
Contamination



**Bronze**



**Steel Spiral**



Scan the QR Code  
to learn more  
about Steer King

# VOLVO T-RIDE

This suspension is for both on- and off-highway applications. It features a parabolic tapered spring pack that is upside-down and mounted outside the frame rails. There is a cushion that sits on each axle that is bolted to the end of each spring to absorb shock and vibration. Four lower torque rods control braking and acceleration forces. These suspensions are popular on waste haulers.

ATRO offers a full complement of load springs, V-rods, torque rods and torque rod bushings. Unlike the OEM, ATRO also offers rebush kits for the V-rods. Polyurethane bushings (and kits) provide chemical resistance and better wear/abrasion resistance than rubber allowing for extended bushing life.

**Load Spring** – ATRO's LP96-24657 load spring utilizes proprietary polyurethane specifically formulated to absorb shock and dampen vibration rather than transferring it into the spring or frame

**V-Rod Assembly** – TR96-44004 (OEM# 20367004) for most applications, and TR96-44829 (OEM# 3172829), the original OEM design. Both are pre-bushed with TH96-22200 at the apex and TS96-22600 (for V-rod TR96-44004) and TS96-22286 (for V-rod TR96-44829) end bushings (see [www.ATROBUSHING.COM](http://www.ATROBUSHING.COM) for additional OEM cross references)

## Lower Torque Rods

- TR96-49046 – fixed length rod, 22 5/8" c-c with rotating pins, snap rings
- TR96-45568 – adjustable rod, rotating pins, snap rings

## Replacement Bushings for V-Rods and Lower Torque Rods

- ATRO's TH96-22200 apex bushing - uses a low friction, high abrasion and wear resistant polyurethane. Fits ATRO V-rods TR96-44004 and TR96-44829.
- TS96-22600 – end bushing; fits ATRO V-rod TR96-44004 (and OEM or others V-rods) and has split outer sleeve to conform to inconsistent eye sizes
- TS96-22286 – end bushing; fits ATRO V-rod TR96-44829 (and OEM or others V-rods) and has split outer sleeve to conform to inconsistent eye sizes
- TS96-22700 – for all lower rod positions, fits both fixed and adjustable
- All ATRO torque rod bushings and V-rod end bushings for the T-Ride have rotating pins for easy installation and elimination of torsional stress, crimped outer sleeves, chemical bond to outer sleeves and snap rings



### WEAR ITEMS

- Torque rods (V-rods and lower torque rods), particularly the V-rod's apex bushing
- Load springs



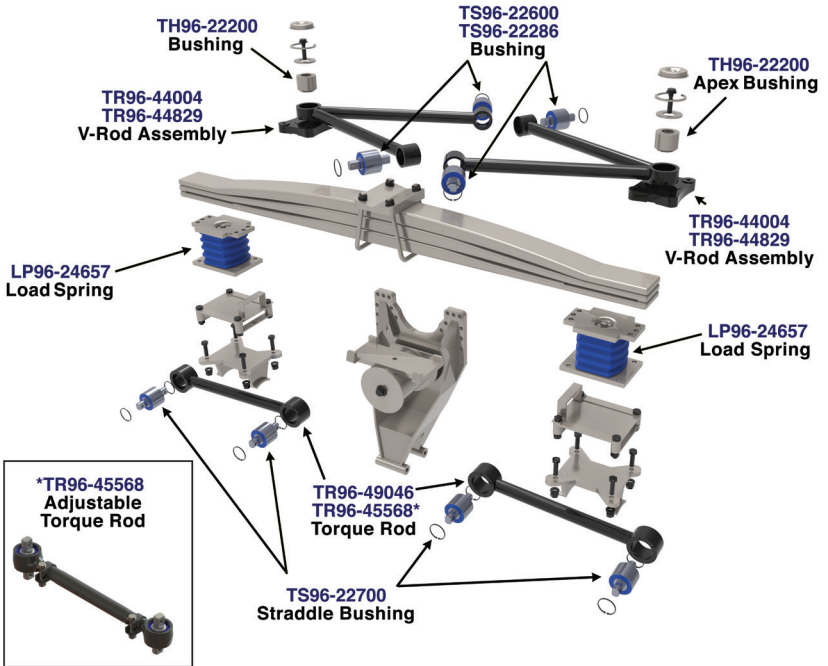



# HENDRICKSON INTRAAX/ VANTRAAX

The Intraax is an integrated trailer air suspension, axle and brake system introduced in 1995. It is widely used and can be found on platforms, tankers, dumps, grain hoppers, specialty trailers – on-highway or off-road. The Vantraax is a tandem air slider system for dry-freight, refrigerated and specialty van trailers and has been available since 1998.

These suspensions feature a “tri-functional” bushing which controls three separate road forces:

- Vertical forces absorbed to reduce stress on the axle
- Horizontal movement during braking and acceleration
- Roll stability to maintain control while turning

The OEM rubber bushing can be difficult to install because it has an oversized outer diameter in order to achieve a press fit into the axle beam and to compress the rubber to a hardness that will carry the load. The voids then allow for movement in the bushing.

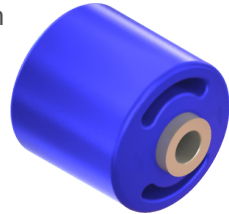

**PB50-36000**  
PIVOT BUSHING/  
TRI-FUNCTIONAL BUSHING

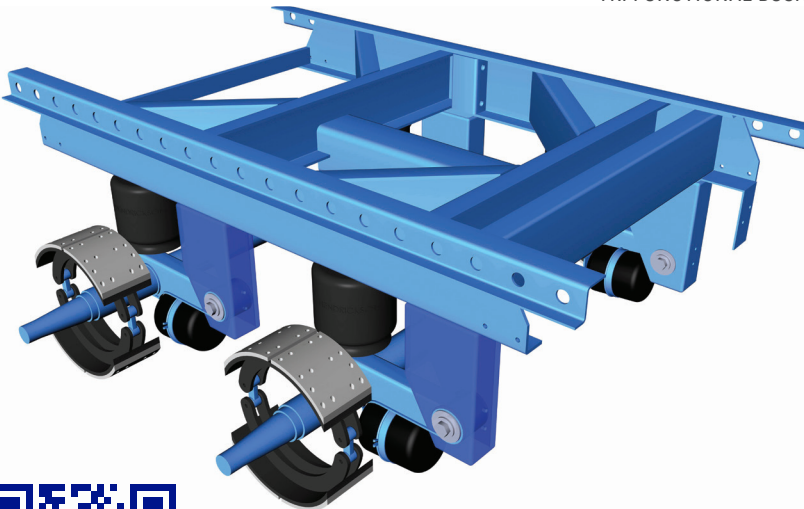

Scan QR Code to go to video:  
**ATRO Parts | Hendrickson INTRAAX®  
VANTRAAX® Suspension**

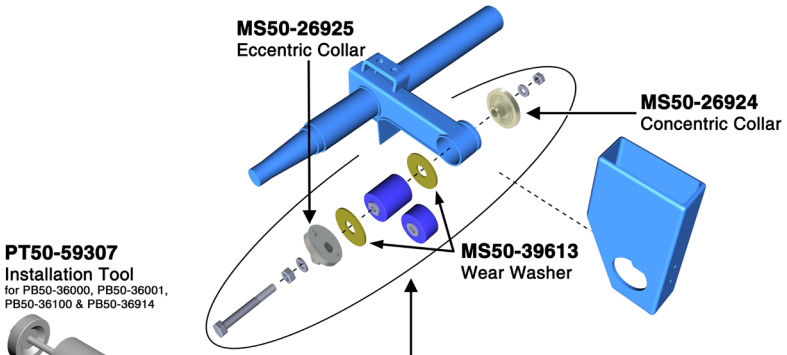
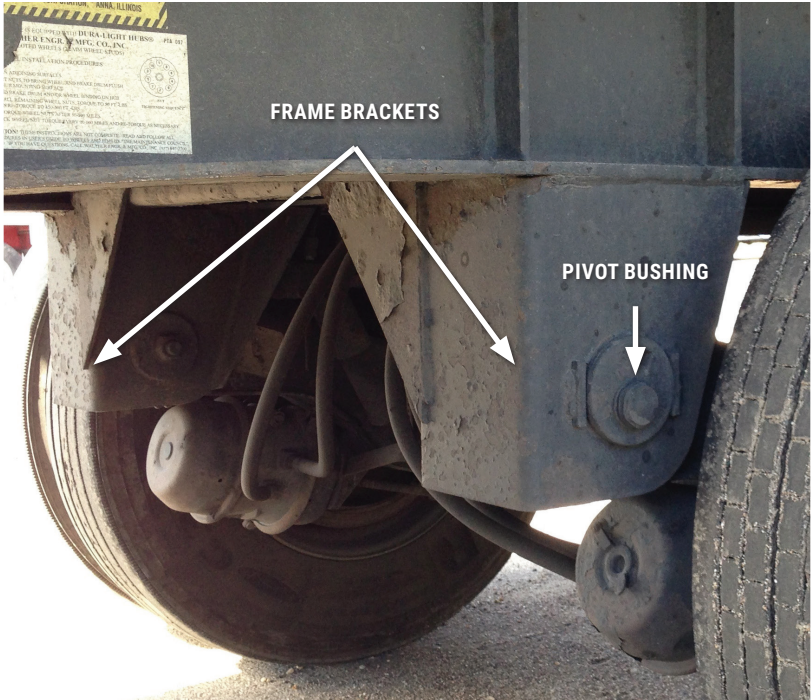

**PT50-59307**  
 Installation Tool  
 for PB50-36000, PB50-36001,  
 PB50-36100 & PB50-36914

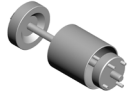

**PT50-59736**  
 Installation Tool  
 for PB50-36321 & PB50-36322

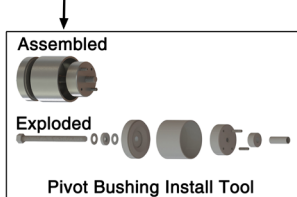

- PB50-36000** (standard hardware)  
Pivot Bushing Kit
- PB50-36001**  
Pivot Bushing Kit w/**HW50-26679** SHEAR Bolt Kit
- PB50-36100**  
Pivot Bushing Kit (no hardware)
- PB50-36321**  
Pivot Bushing Kit (for narrow beam)
- PB50-36322**  
Pivot Bushing Kit w/**HW50-26705** SHEAR Bolt Kit (for narrow beam)
- PB50-36364**  
Pivot Bushing ONLY (for narrow beam)

# HENDRICKSON INTRAAX/ VANTRAAX

## Direct Replacement Bushings

- Voids like the standard rubber bushing
- Outer diameter is slightly smaller than OEM rubber bushings
- The inner sleeve is bonded in place
- Chemically-resistant polyurethane material

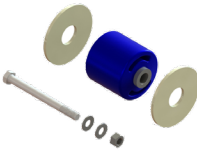

**PB50-36000**  
STANDARD BOLT

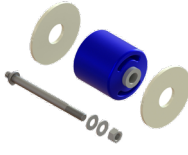

**PB50-36001**  
SHEAR BOLT

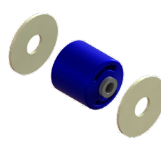

**PB50-36100**  
NO BOLT

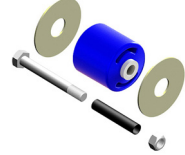

**PB50-36914**  
STANDARD BOLT  
W/BOLT SLEEVE

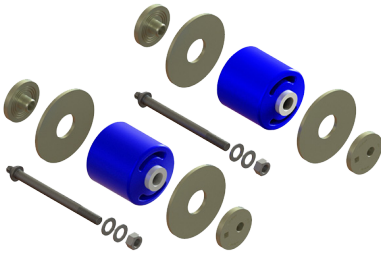

**PB50-36654**  
COMPLETE AXLE  
PIVOT BUSHING KIT

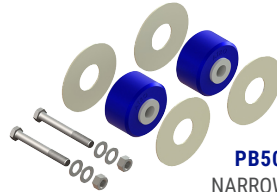

**PB50-36321**  
NARROW BUSHING  
STANDARD BOLT

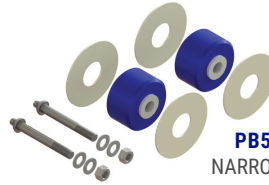

**PB50-36322**  
NARROW BUSHING  
SHEAR BOLT

ATRO P/N	OEM Bushing	Voids	Inner pin rotation	Bolt type	
PB50-36000	S-24691	Yes	No	Hex head	
PB50-36001	S-24691	Yes	No	Shear Bolt	
PB50-36100	S-24691	Yes	No	n/a	
PB50-36321	S-26321	Yes	No	Hex head	
PB50-36322	S-26321	Yes	No	Shear Bolt	
PB50-36914	A-6914	Yes	No	Hex head	
PB50-36654	S-24691	Yes	No	Shear Bolt	

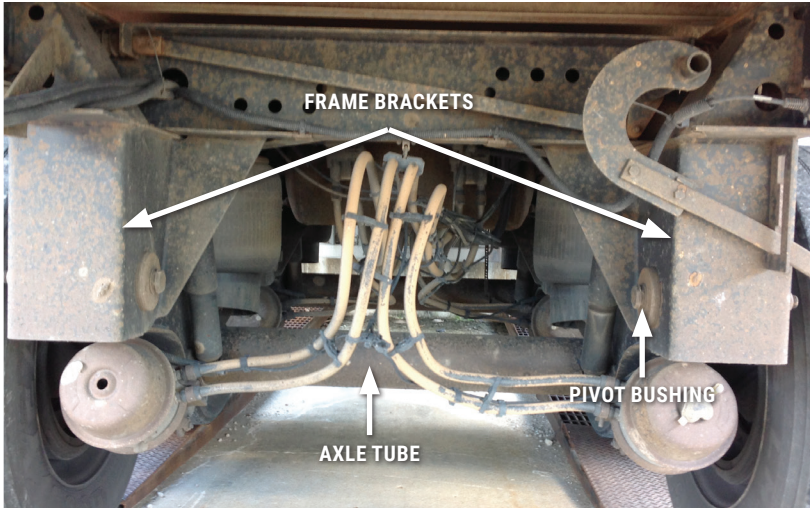

### TECH TIP

ATRO's installation tools will install/remove OEM bushings and/or ATRO bushings. Conversely, the OEM tool can be used to install/remove both OEM and ATRO.

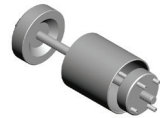

**PT50-59307**

WIDE 6 3/4" BUSHING

**PT50-59376**

NARROW 3 5/8" BUSHING



### WEAR ITEMS

Tri-functional bushing

- Mode of failure: bushing tube spacers melt, inner sleeve separated from rubber.
- Cause: excessive vertical movement of suspension arm caused buildup of excessive heat
- Note: check to see if tires are out of balance or if shocks have failed

	Hardware included	Alignment	Install tool	Qty/axle
	Yes	Quick-Align	PT50-59307	2
	Yes	Quick-Align	PT50-59307	2
	Wear washers only	Quick-Align	PT50-59307	2
	Yes	Quick-Align	PT50-59376	1
	Yes	Quick-Align	PT50-59376	1
	Yes	Welded Alignment	PT50-59307	2
	Yes	Quick-Align	PT50-59307	1

# HUTCHENS 7700/9700

This traditional leaf spring trailer suspension is available in single, tandem or multi-axle configurations, overslung or underslung and is adaptable to square, round or rectangular axles. It can have cast or fabricated equalizers and hangers.

## Atro offers:

- Cast or fabricated equalizers
- Equalizer kit includes hardware – no need for separate purchase of hardware kit
- Torque rod bushings (PL1119 with retaining rims)
  - 2-piece design for easy installation



## WEAR ITEMS

- Equalizer/bushings
- Torque rods/bushings





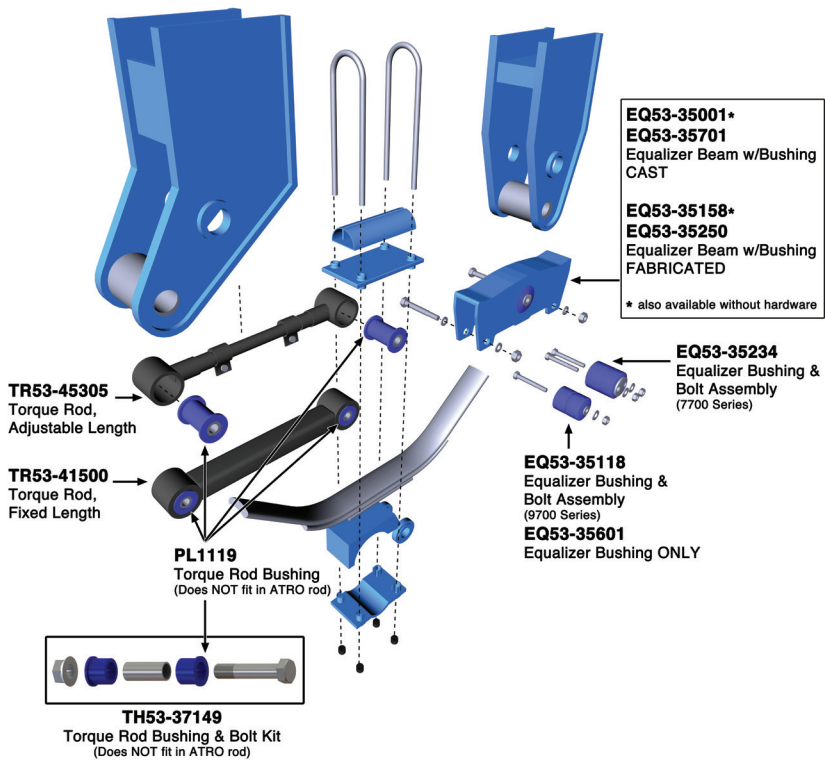

Scan QR Code to go to video:  
**ATRO Parts | Hutch Trailer Suspension**



# MERITOR RHP/MPA TRAILER

These trailer suspensions have a parallelogram design with parallel upper and lower control arms. Both upper and lower control arms are bolted to a central V-shaped frame bracket instead of having two separate trailing arms. The air springs mount directly over the axles for a smoother ride, elimination of roll torque and to prevent dock walk. The upper control arms are held together by a torque tube designed to control lateral roll. Approved applications include pup trailers, dry van and refrigerated van.

## Identification

- RHP, manufactured through 2007, has solid face on frame bracket.
- MPA (Ride Sentry), produced 2007/2008 through current has open triangle on central frame bracket face.

## ATRO's long-life bushing replacements

ATRO's upper control arm bushings offer chemical resistance to environmental factors and easier installation compared to a bonded rubber bushing. ATRO's 1- and 2-piece designs both allow controlled motion of the upper control arm without causing bushing windup because the polyurethane bushings are not bonded to the inner sleeves. In the lower torque rods, this free-rotation design eliminates bushing windup along with shear and torsional stresses from the torque rods.

## ATRO Parts for Upper Control Arm

SU99-39113	One-piece pivot bushing	8 per vehicle	No hardware	OEM #A1225L1416, A1225G1437
SU99-39114	Upper control arm service kit	2 per vehicle	Hardware and 4 SU99-39113 included	OEM # KIT11300
SU99-39115	Two-piece pivot bushing	8 per vehicle	No hardware	OEM # KIT11126
SU99-39116	Upper control arm service kit	2 per vehicle	Hardware and 4 SU99-39115 included	OEM # KIT11101

## ATRO Lower Torque Rod (Lower Control Arm)

PL1118	Two-piece torque rod bushing	4 per vehicle	No hardware	OEM# M3032502E
TH99-37102	Torque rod service kit	4 per vehicle	Hardware and 1 PL1118 included	OEM # KIT11102

## WEAR ITEMS

- Control arms and brackets
- Bushings
- Axles and axle seats
- Cross tubes and frame
- Shock absorbers

## Torque Specs (unless otherwise specified by OEM for specific suspension model)

- Upper and lower control arms torque to 540-560 ft-lbs
- Exception: upper control arm, side plate end – roadside torque to 590-610 ft-lbs
- Lower control arm clamp bolts torque to 160-170 ft-lbs after aligning axle

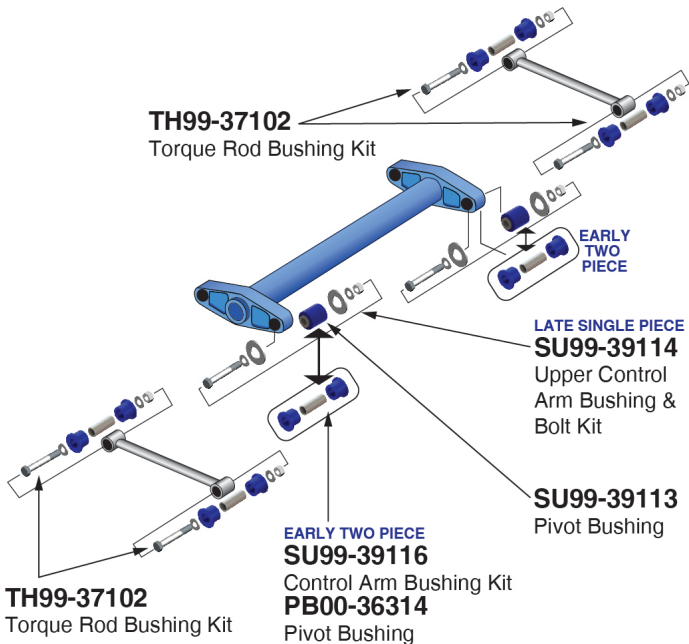

# REYCO 21B

This 4-spring trailer suspension for heavy-duty applications including tankers, low beds, rear/belly/side-dumps, flat decks and platforms. Polyurethane equalizer bushings (and kits) provide chemical resistance and better wear/abrasion resistance than rubber. This results in extended bushing life.

## ATRO offers a full complement of equalizer bushings, bushing kits, torque rods and torque rod bushings

- EQ83-35300 cast equalizer for 49" axle spacing with cast hangers (Use with ATRO's polyurethane bushing assembly, SK83-310000)
- EQ83-11000 – polyurethane equalizer bushing (requires 2 per equalizer)
- SK83-31000 – polyurethane equalizer bushing (EQ83-11000) kitted with attaching hardware and shaft (1 per equalizer)
- TH83-37997 – polyurethane torque rod bushings (PL1116) kitted with attaching hardware (2 per complete torque rod)
- PL1116 – 2-piece polyurethane torque rod bushing (requires 4 per complete torque rod)

## Torque Specs (unless specified by OEM for specific suspension model)

- Torque rod bolts (1") should be tightened to 140-160 ft/lb of torque. (Initial torque value may drop as bushings settle in. Not necessary to re-torque after proper bushing clamp is achieved.)
- Equalizer bolts (1") should be torqued to 400-450 ft/lb



### WEAR ITEMS

- Equalizer bushings and pins
- Torque rod bushings and bolts

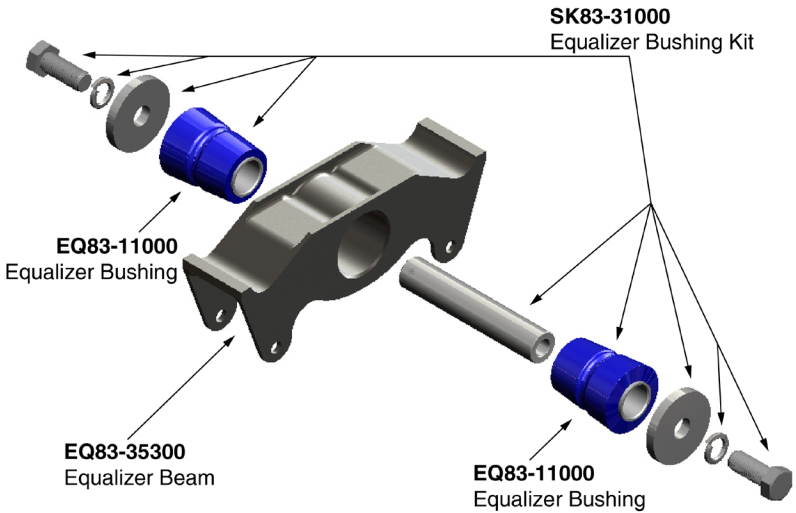
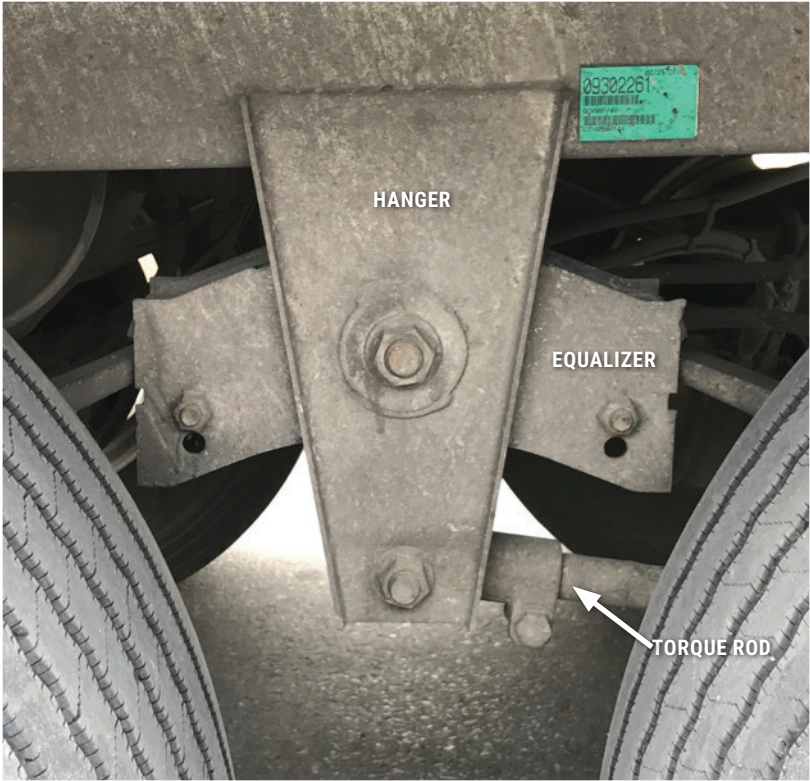



# TORQUE RODS

## Purpose of a Torque Rod

- Restrain rotation of the axle housing during acceleration and braking
- Locate the axle and maintain alignment
- Control driveline angle
- Absorb leaning and cornering forces



## Key Technical Point

Transverse rods must be perpendicular to the frame rail when installed. If not installed properly:

- The inner pin could break
- The torque rod could break
- The bushing could walk out of the rod
- Warranty may be void



## When should rods be rebushed or replaced?

- Bent torque rod
- More than 1/8" movement at the rod eye. Check by hand or by prying against end with a bar
- Bushing material is torn or cracked
- Pin or sleeve in the rod eye is off-center (pin appears to be "walking out" of rod eye)
- Pin/sleeve is no longer located in the vertical center of the rod eye
- Bolt hole in straddle pins is stretched, elongated

## COMMON TORQUE RODS

### CONCRETE & REFUSE

TR13-41635  
TR50-41615  
TR59-41150  
TR71000  
TR76000

### FREIGHTLINER

TR46-41000  
TR46-41002  
TR46-41716

### INTERNATIONAL

TR55-41117  
TR55-418C1  
TR55-428C1

### KENWORTH

TR00-41009  
TR00-46600  
TR59-41008  
TR59-41150  
TR59-41375  
TR59-41376  
TR59-41474

### PETERBILT

TR00-41001  
TR00-41009  
TR75-41059  
TR75-41108  
TR75-41327  
TR75-41440

### VOLVO/MACK

TR62-41180  
TR62-41220  
TR62-41832  
TR62-41243  
TR96-41003  
TR96-41068

## Function of a Torque Rod



**RESTRAIN AXLE ROTATION**



**LOCATE AXLE, MAINTAIN ALIGNMENT**



**CONTROL DRIVELINE ANGLE**

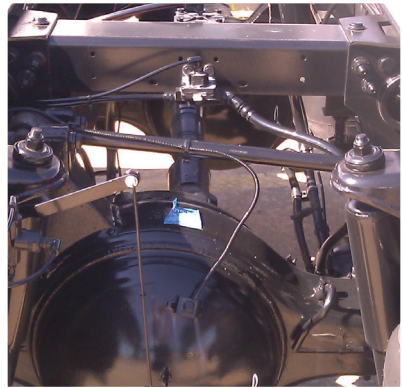

**ABSORB LEANING, CORNERING FORCES**

## Rebush or Replace?



**BUSHING MATERIAL IS TORN OR CRACKED**



**BUSHING "WALK-OUT"**

# IDENTIFY A TORQUE ROD

## Identify Correct Length

Measure from center of bushing to center of bushing



OR

Outside edge of eye ID to inside edge of the other eye ID



## Identify Bushing Style on Each End

**Straddle bushings have bolt holes on either side of the rod.**



- Measure the bolt hole size – typically 5/8", 3/4", or 7/8"
- Measure the bushing OD – typically around 2" or 2.75"
- Are the bolt holes round or slotted? Most will be round.

**Taper Bushings look like a large tie rod**



- Measure overall length of the bushing from tip of threads through the bushing to the base of the bushing, not including the retaining washer
- Measure the bushing OD – typically around 2" or 2.75"

**Hollow Bushings have a bolt that passes through**

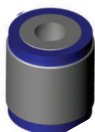

- Measure the bolt hole size (Inside Diameter)
- Measure the bushing OD – typically around 2" or 2.75"

# IDENTIFY A TAPER PIN BUSHING

- Bushing Outside Diameter (OD)
- Total Length of Taper, including bushing but not including the retaining washer
- Thread Size

## PRESS FIT TAPER BUSHINGS

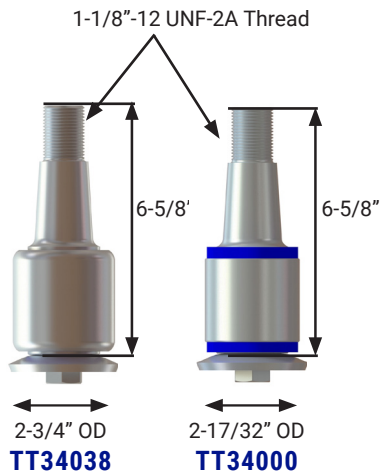
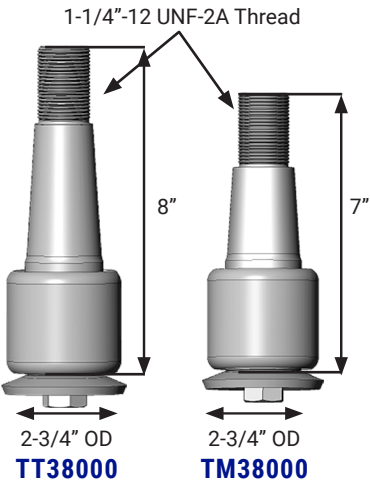

## PRESS FIT TAPER BUSHINGS

For ATR0 Small Eye Rods ONLY

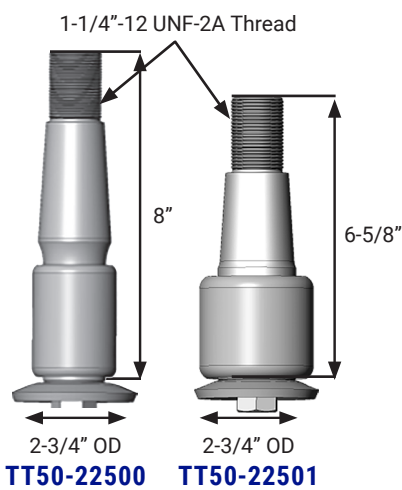

## JAM STYLE TAPER BUSHINGS

For Hendrickson ULTRA ROD®

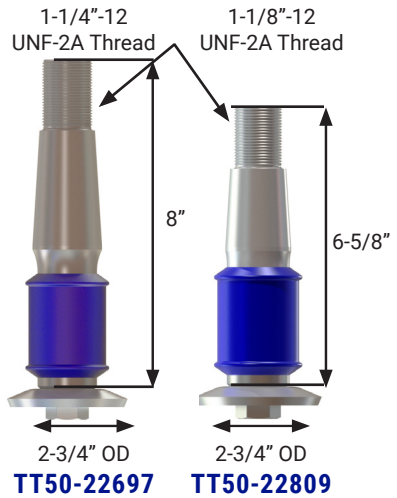

# ATRO'S VIN-LESS® TORQUE ROD FINDER



ATRO has compiled a master database to simplify and expedite the process of finding replacement rods. Shorten the time at the counter and confirm the right part for your customer.

Go to [ATROBUSHING.COM](http://ATROBUSHING.COM)

Click on the Torque Rod Finder in the upper right hand corner

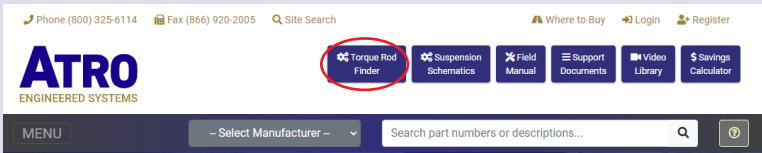



## 1 Visually Identify the Rod

Select the types of bushings Straddle, Taper or Hollow

1 SELECT STYLE    2 SELECT LENGTH    3 FIND TORQUE ROD

  
STRADDLE-STRADDLE  
[Select](#)

  
STRADDLE-TAPER  
[Select](#)

  
TAPER-TAPER  
[Select](#)

  
STRADDLE-HOLLOW  
[Select](#)

  
HOLLOW-HOLLOW  
[Select](#)

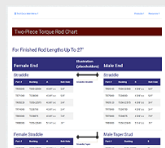
  
TWO-PIECE CHART  
For finished rod lengths up to 27"



Scan QR Code to go to  
**ATRO's VIN-LESS® Torque Rod Finder**



## 2 Measure the Rod

Measure from center of bushing to center of bushing or outside of one eye to inside of the other eye (refer to page 70).

1 SELECT STYLE    2 SELECT LENGTH    3 FIND TORQUE ROD

Configuration:  
Straddle - Straddle

Filter the C-C length

14 3/16" c-c	14.31" c-c	14 3/8" c-c	14.41" c-c	14 3/4" c-c	15 3/16" c-c	15 3/8" c-c
15 3/4" c-c	15.13/16" c-c	16 1/8" c-c	16 1/2" c-c	16 9/16" c-c	16 5/8" c-c	16 15/16" c-c
17 1/8" c-c	17 5/16" c-c	17 3/8" c-c	17 15/16" c-c	18 1/8" c-c	18 5/16" c-c	18.7" c-c
19 1/16" c-c	19 1/8" c-c	19 1/2" c-c	19 11/16" c-c	19 3/4" c-c	19 7/8" c-c	20" c-c
20 1/16" c-c	20 1/4" c-c	20.31" c-c	20 1/2" c-c	20 11/16" c-c	20 7/8" c-c	21" c-c
21 1/16" c-c	21 1/8" c-c	21 1/4" c-c	21 7/16" c-c	21 1/2" c-c	21 5/8" c-c	21 3/4" c-c
21 13/16" c-c	21 7/8" c-c	21 15/16" c-c	21 31/32" c-c	22" c-c	22 1/16" c-c	22 1/8" c-c



### TECH TIP:

Sometimes the field measurement of a rod can be off by a little bit. In the Torque Rod Finder, check the measurements just a little longer or shorter than what you have and often you will find a very popular rod that is exactly what you need! Most suspensions are predictable and use common torque rods!

## 3 Results found with bushing and bolt hole detail

1 SELECT STYLE    2 SELECT LENGTH    3 FIND TORQUE ROD

Configuration:  
Straddle - Straddle  
20 1/16" c-c Length

Notes:

C-C

A B

TR50-42510

BUSHING A (TS38000)			BUSHING B (TS38000)		
LENGTH CC	OD	BOLT HOLE	LENGTH CC	OD	BOLT HOLE
4 3/8"	2 3/4"	5/8"	4 3/8"	2 3/4"	5/8"

# FREE-ROTATION TORQUE ROD BUSHING

## One Bushing Works Around the Clock

ATRO's free rotation polyurethane torque rod bushings outperform rubber bushings.

### Benefits of the Rotating Pin

- Faster, easier installation
- One rod fits any clocking angle
- Eliminates bushing wind-up
- Reduces stress on ENTIRE suspension
- Longer life means less downtime & fewer rods to stock
- The polyurethane in the bushing is not effected by contaminates such oil, grease, diesel fuel, hydraulic fluids, road salt, cleaning solvents, etc.

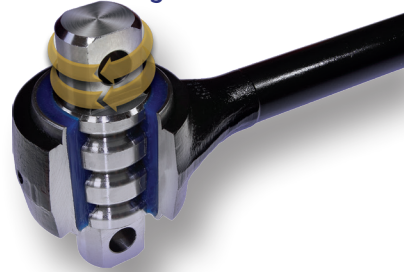

## ATRO VS OEM Small Eye Torque Rods



## 2 Piece Weldable Torque Rods

- Only One Weld
- Large & Small Eye Torque Rod Designs
- Ruler on male end rods shows precise final cut-point
- Reduces mistakes and wasted inventory

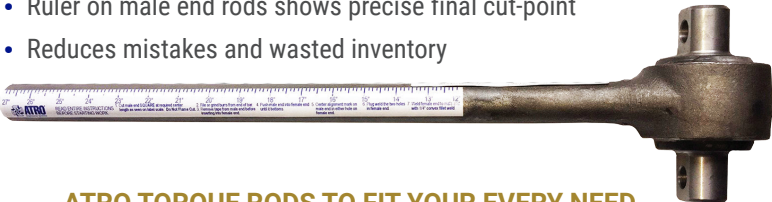

### ATRO TORQUE RODS TO FIT YOUR EVERY NEED

- Large Eye Torque Rods • Small Eye Torque Rods • Two-Piece Torque Rods
- V-Rods • Custom Rods

# Two-Piece Rods Assembly Chart

## FOR FINISHED ROD LENGTHS UP TO 27"

### FEMALE END

#### STRADDLE

PART #	BUSHING A	BOLT HOLE
TR35205	TS00-22500	4 3/8" c-c 5/8"
TR71000	TS38000	4 3/8" c-c 5/8"
TR35220	TS50-22575	4 3/8" c-c 3/4"
TR74000	TS38750	4 3/8" c-c 3/4"
TR82000	TS49000	5 11/16 c-c 3/4"
TR83000	TS38875	4 3/8" c-c 7/8"
TR88000	TS50-22649	5 1/4" c-c .91"



### MALE END

#### STRADDLE

PART #	BUSHING B	BOLT HOLE
TR35105	TS00-22500	4 3/8" c-c 5/8"
TR75000	TS38000	4 3/8" c-c 5/8"
TR35120	TS50-22575	4 3/8" c-c 3/4"
TR78000	TS38750	4 3/8" c-c 3/4"
TR79000	TS38875	4 3/8" c-c 7/8"
TR89000	TS50-22649	5 1/4" c-c .91"

#### FEMALE STRADDLE

PART #	BUSHING A	BOLT HOLE
TR35205	TS00-22500	4 3/8" c-c 5/8"
TR71000	TS38000	4 3/8" c-c 5/8"
TR35220	TS50-22575	4 3/8" c-c 3/4"
TR74000	TS38750	4 3/8" c-c 3/4"
TR82000	TS49000	5 11/16 c-c 3/4"
TR83000	TS38875	4 3/8" c-c 7/8"
TR88000	TS50-22649	5 1/4" c-c .91"



#### MALE TAPER STUD

PART #	BUSHING B	LENGTH
TR35110	TT50-22500	8"
TR76000	TT38000	8"
TR77000	TM38000	7"
TR35125	TT50-22501	6 5/8"
TR81000	TT34038	6 5/8"

#### FEMALE TAPER STUD

PART #	BUSHING A	LENGTH
TR35210	TT50-22500	8"
TR72000	TT38000	8"
TR73000	TM38000	7"
TR35225	TT50-22501	6 5/8"
TR80000	TT34038	6 5/8"



#### MALE STRADDLE

PART #	BUSHING B	BOLT HOLE
TR35105	TS00-22500	4 3/8" c-c 5/8"
TR75000	TS38000	4 3/8" c-c 5/8"
TR35120	TS50-22575	4 3/8" c-c 3/4"
TR78000	TS38750	4 3/8" c-c 3/4"
TR79000	TS38875	4 3/8" c-c 7/8"
TR89000	TS50-22649	5 1/4" c-c .91"

#### TAPER STUD

PART #	BUSHING A	LENGTH
TR35210	TT50-22500	8"
TR72000	TT38000	8"
TR73000	TM38000	7"
TR35225	TT50-22501	6 5/8"
TR80000	TT34038	6 5/8"



#### TAPER STUD

PART #	BUSHING B	LENGTH
TR35110	TT50-22500	8"
TR76000	TT38000	8"
TR77000	TM38000	7"
TR35125	TT50-22501	6 5/8"
TR81000	TT34038	6 5/8"

#### STRADDLE

PART #	BUSHING A	BOLT HOLE
TR35205	TS00-22500	4 3/8" c-c 5/8"
TR71000	TS38000	4 3/8" c-c 5/8"
TR35220	TS50-22575	4 3/8" c-c 3/4"
TR74000	TS38750	4 3/8" c-c 3/4"
TR82000	TS49000	5 11/16 c-c 3/4"
TR83000	TS38875	4 3/8" c-c 7/8"
TR88000	TS50-22649	5 1/4" c-c .91"



#### HOLLOW

PART #	BUSHING B	ID
TR35115	TH00-22500	7/8"
TR85000	TH50000	1 1/8"
TR87000	TH99-22101	7/8"

#### HOLLOW

PART #	BUSHING A	ID
TR35215	TH00-22500	7/8"
TR84000	TH50000	1 1/8"
TR86000	TH99-22101	7/8"



#### HOLLOW

PART #	BUSHING B	ID
TR35115	TH00-22500	7/8"
TR85000	TH50000	1 1/8"
TR87000	TH99-22101	7/8"

**Blue indicates small eye Two-Piece Torque Rods with 2" OD Bushings**  
**All other Two-Piece Torque Rods feature 2 3/4" OD Bushings**

# FAILED TORQUE ROD GUIDE

## CORROSION

This can be caused by a chemical attack such as acid wash or road treatments.

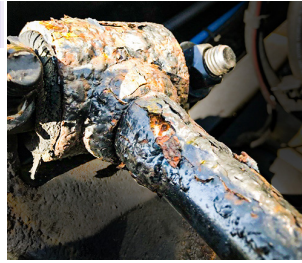

## BUSHING WIND-UP

This is a condition that is caused when the clocking of the bushing is not correct. It can be seen in rotational cracks at the end of the bushings. While not technically failed, it is an indicator that failure is approaching.



## TORN ELASTOMER

This can be caused by overextension beyond the articulation capabilities or repeated shock to the bushing.



## BUSHING EXTRUSION OR DEFORMATION

This can be caused by exceeding the rating of the suspension or contaminants that cause an "oil soaked" condition.



## CATASTROPHIC FAILURE

This is usually caused by one of the other issues going unnoticed to the point the elastomer deteriorates completely.



## BUSHING WALKOUT

This can be caused when the transverse rod is not perpendicular to the frame rail.

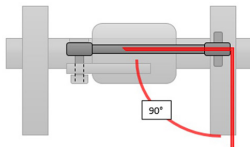

## BENT OR BROKEN RODS

This is typically caused by overloading the suspension or impact such as hitting a curb.



## DAMAGED GREASE SEALS

This condition is caused by impact with a foreign object such as road debris or a fifth wheel latch hook.



## DAMAGED STRADDLE PINS

This can be caused by hardware tightness, misalignment, or impact to the rod.



## DRY ROT

This is caused by age, heat, UV rays, temperature extremes, ozone, oxidation, and lack of use. It is evident by cracks in what otherwise appears to be a good bushing. This is a sign that the material has been compromised and should be replaced.

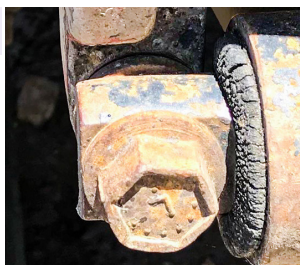



# ATRO

## ENGINEERED SYSTEMS

6 Bolte Lane  
St. Clair, Missouri 63077 | U.S.A.  
(800) 325.6114 | Fax (866) 920.2005  
ATROBUSHING.COM

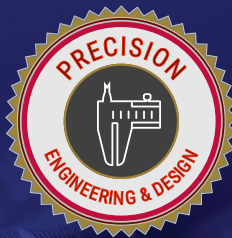

With ATRO behind you, **drive forward.**

ATRO, LLC is not liable for any errors herein. All manufacturers' names and part numbers are used without permission; no endorsement, affiliation, or recommendation is implied. They are included for reference purposes only. © 2022 ATRO, LLC