

---

**FIELD WELDING AND  
CUTTING DUCTILE  
IRON PIPE**



# FIELD WELDING AND CUTTING DUCTILE IRON PIPE

By Richard W. Bonds, P.E.  
Research and Technical Director

## Notice

**D**UCTILE IRON PIPE MANUFACTURERS have been successfully welding Ductile Iron pipe for many years and should be consulted on their recommendations for field welding and torch cutting their product. The Ductile Iron Pipe Research Association (DIPRA) does not support indiscriminate field welding of Ductile Iron pipe. However, unforeseen circumstances might require field welding of retainer rings, thrust collars, etc., onto the barrels of Ductile Iron pipe.

This manual is intended as a guide for field welding and cutting cement-mortar-lined and unlined Ductile Iron pipe. For welding or cutting special lined pipe, consult the pipe manufacturer.

The procedures described are intended to be used only by qualified welders having adequate skill and experience in the practice of the appropriate welding and cutting methods for cast ferrous materials. Only such qualified welders should be allowed to field weld and field cut restrained joints for Ductile Iron pipe. Pipe manufacturers' recommended procedures shall be followed while exercising reasonable care. Care should also be exercised in the application of the principles contained herein. DIPRA assumes no responsibility and disclaims liability for the design or performance of pipe joints or pipe systems fabricated with this approach. Also, DIPRA assumes no responsibility and disclaims liability for injury or damage to persons or property arising from the use of these procedures.

## Introduction

Welding is a very important fabrication method in modern industry. If an alloy can be welded successfully, its usefulness is clearly enhanced. Ductile Iron can be welded successfully to produce welds

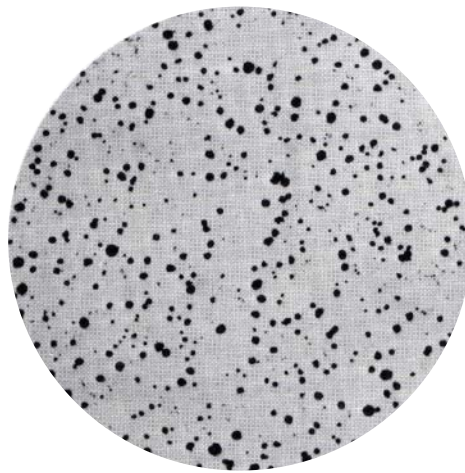

Ductile Iron



Gray Iron

**As these photomicrographs show, Ductile Iron differs from Gray Iron in that its graphite is spheroidal, or nodular, instead of the flake form found in Gray Iron. Ductile's greater strength, ductility, and toughness are due to this change in microstructure.**

that have mechanical properties comparable to those of the base iron.

As with any base material, the success of welding Ductile Iron depends on suitable equipment, correct procedures, qualified welders, and effective quality control procedures.

## Ductile Iron Pipe

The first Ductile Iron pipe was cast experimentally in 1948. Years of metallurgical, casting, and quality control refinement followed, and in 1955 Ductile Iron pipe was introduced into the marketplace.

Its phenomenal strength and impact resistance compared to Gray Iron, along with many other advantages, created a rapid increase in demand for this product as engineers and utility officials realized that it could be transported, handled, and installed with virtually no damage to the pipe. In service, Ductile Iron pipe showed that expense of repair was practically eliminated.

Ductile Iron is usually defined as a Cast Iron with primary graphite in the nodular or spheroidal form. This change in the graphite form is accomplished by adding an alloy, usually magnesium, to molten iron of appropriate composition.

Properly treated iron will solidify with the graphite in the form of nodules or spheroids. The distribution and shape of the graphite nodules are set when the metal solidifies in the mold and will remain essentially unchanged during subsequent processing. Because of the mold cooling and rapid iron solidification, the pipe must be annealed (heat treated) to produce the necessary proportion of ferrite that imparts strength, ductility, and impact properties required by specifications for water service.

The annealing treatment relieves casting stresses and produces the microstructural transformation that increases the toughness and improves ductility of the

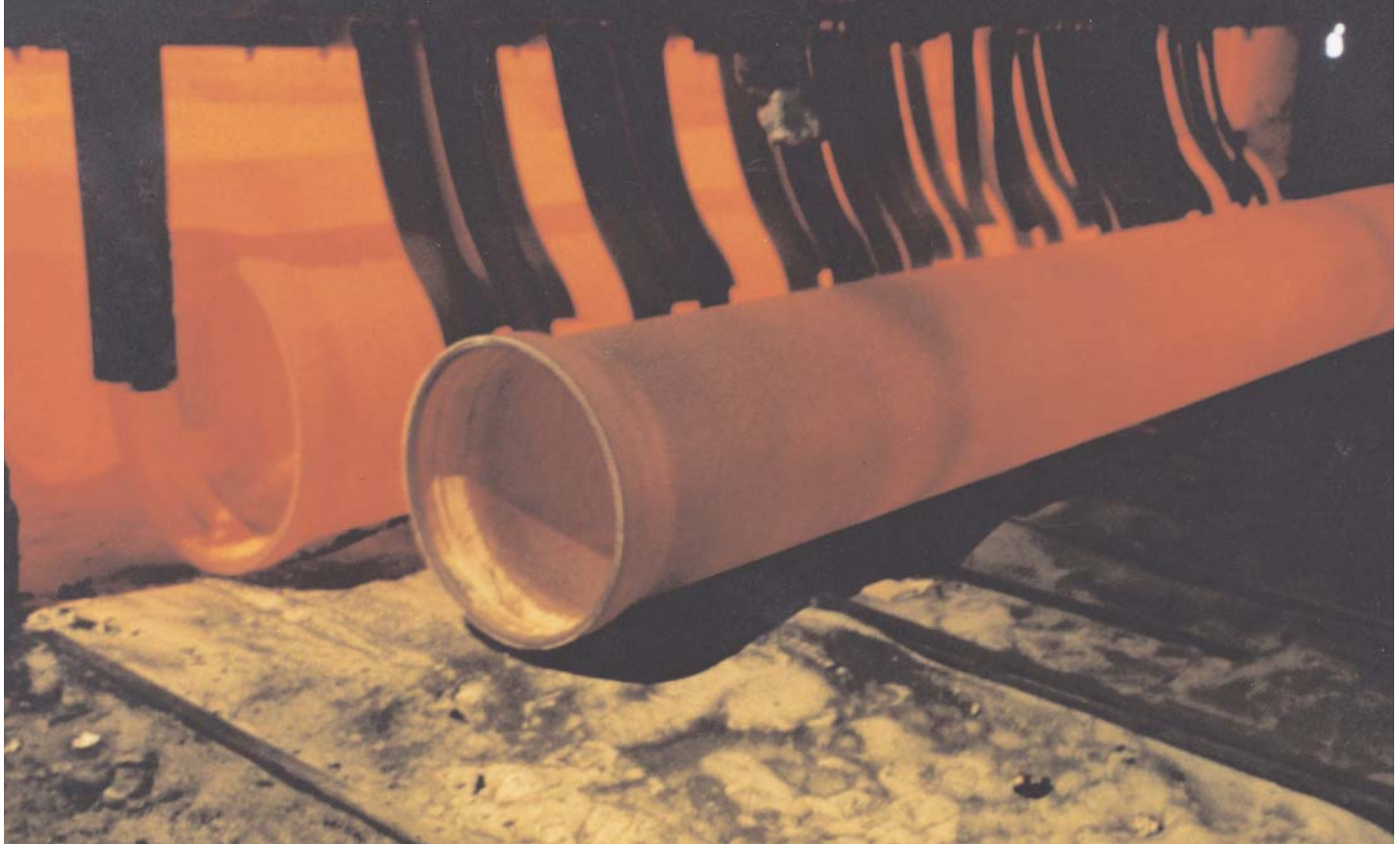

**The annealing treatment for Ductile Iron pipe relieves casting stresses and produces the microstructural transformation that increases the pipe's toughness and improves the ductility of the iron while maintaining the required strength.**

iron while maintaining the required strength. The effectiveness of the magnesium treatment of the iron as well as the annealing treatment of the pipe is proven by means of physical tests. The types of tests, test frequencies, and acceptance limits that are required are specified in ANSI/AWWA C151/A21.51 Standard, "Ductile-Iron Pipe, Centrifugally Cast, for Water." The acceptance test requirements of the ANSI/AWWA C151/A21.51 Ductile Iron Pipe Standard are:

1. Tensile properties of specimens machined from the pipe wall: ultimate strength, 60,000 psi minimum; yield strength, 42,000 psi minimum; elongation, 10 percent minimum.
2. Charpy V-Notch impact strengths on specimens cut from the pipe wall: 7 ft-lb minimum at 70°F; 3 ft-lb minimum at -40°F.

Ferritic Ductile Iron, as compared to Gray Iron, will have about twice the strength as determined by a tensile test, beam test, ring bending test, and bursting test. The tensile elongation and impact strength of Ductile Iron are many times that of Gray Iron.

## *General Welding of Iron Pipes*

### **Weldability of Ductile Iron**

Due to their high carbon content, all cast

irons have a common factor affecting their weldability. During the welding of cast irons, the iron immediately adjacent to the weld metal is heated to its fusion or melting point. After welding, the entire heat-affected zone cools very rapidly. During this heating and cooling, some of the graphitic carbon dissolves and diffuses into the iron, and, as a result, carbides tend to form at the edge of the fusion zone, and high-carbon martensite and bainite tend to form in the remainder of the heat-affected zone. The formation of these hard, brittle microconstituents increases the susceptibility to cracking. The lower surface-to-volume ratio of the nodular graphite in Ductile Iron as compared to that for the flake graphite in Gray Iron results in less carbon dissolution and the formation of fewer carbides and less high-carbon martensite.

Also, because of its localized nature, welding produces thermal stresses in the weld area. Ductile Iron pipe, having a predominantly ferritic matrix, is capable of local plastic deformation to accommodate these welding stresses and is therefore better suited to absorb welding stresses than is Gray Iron. Successful welds can be made by minimizing the stress from contraction of the weld metal as it cools, the pick-up of carbon by the weld metal, and by controlling the rate of cooling.

### **Preparation for Welding**

The success of any welding operation is affected by how effectively the preparation and cleaning operations are carried out prior to welding. The welding area on the pipe and connecting piece must be untarnished, dry, and grease-free. It has been found that the asphaltic coating on the pipe can most easily be removed with a torch. An alternate method is to wash and wipe the area with a well-soaked rag containing mineral spirits or other solvents. (Safety precautions must be observed when using flammable materials.) After the asphaltic coating and any grease, etc., have been removed from the weld area, the area should be ground to bright metal to remove all annealing oxide. Also, the corresponding surface of the Ductile Iron or alloy steel connecting piece to be welded should be cleaned and ground to bright metal. A shot-blasted surface alone is not adequate for welding.

### **Weld Joint Design**

Most weld joint designs commonly used for welding carbon steels are generally suitable for welding Ductile Iron (butt welding is not recommended).

### **Preheating**

Preheating involves raising the temperature of the base metal in the region to be welded to a predetermined temperature prior to carrying out the welding

process. Preheating may be applied to help prevent cold-cracking, reduce hardness in the heat-affected zone, reduce residual stresses, and reduce distortion.

Normally, preheating of Ductile Iron pipe is not necessary and is impractical to do in the field. However, in extreme cold weather one may find it advantageous to warm the pipe weld area with a torch.

### Shielded Metal-Arc Welding

Shielded metal-arc welding is the most common welding process used on Ductile Iron pipe in the field. The equipment necessary for shielded metal-arc welding is as follows:

1. D.C. arc welder using reversed polarity.
2. Suitable welding electrodes.
3. Welding cable, work-piece cable, electrode holder, gloves, shield and protective clothing.

Electrodes for metal-arc welding are normally covered with a flux coating. The coating can fulfill the following functions:

1. Stabilize the arc by ionization.
2. Provide protection for the molten metal from the atmosphere by evolution of gases such as carbon dioxide and by hydrogen and also by the formation of a protective slag or flux.
3. Influence the properties of the weld metal by de-oxidation and alloying.
4. Control the arc characteristics.

### Recommended Electrodes

Some electrodes recommended for welding Ductile Iron are the 44- and 55-percent nickel-iron electrodes. **Consult pipe manufacturer for recommendations.** These electrodes provide weld metal strength and toughness properties that are comparable to those of the base iron. The 44- and 55-percent nickel-iron electrodes should be in conformance with class designation AWS A5.15

(ERNi-CI) and (ENiFe-CI) respectively. These electrodes are capable of producing suitable welds without preheating or postheating the pipe or connecting piece. Nickel-iron electrodes are available from most of the leading electrode manufacturers and, although composition with reference to nickel and iron content remains broadly the same, differences in slag-stripping qualities and operation may be found in electrodes obtained from different sources. Two nickel-iron electrodes are Inco Alloys International's Ni-Rod 44 and Ni-Rod 55. Mild-steel, arc-welding electrodes are not recommended for use with Ductile Iron because of the high risk of cracking at the interface of weld and base metal.

Deposited metal from the ENiFe-CI electrode has a carbon content well above the solubility limit. The excess carbon is rejected as graphite during solidification of the weld metal. This reaction causes an increase in volume that tends to minimize weld shrinkage during solidification. This, in turn, reduces residual stresses in the weld metal and the iron's heat-affected zone.

### Care of Electrodes

Electrodes must be completely free from moisture when used. Porosity in the weld can and often does originate because of moisture pick-up by the electrode coating. It is invariably due to the fact that the electrodes have been stored in unsatisfactory conditions. Ideally, electrodes should be stored in an oven maintained at a temperature of at least 250°F. If they have not been stored under these conditions they should be baked for at least 1 hour at 480°F in a well-ventilated electric oven prior to use. The practice of drying electrodes by shorting them out is not recommended. Excessive heating by this method, apart from having adverse effects on the power source, can damage the coatings and thus reduce their shielding efficiency when used.

### Welding Procedures

Welding current for a particular electrode size should be within the range recommended by the manufacturer but as low as possible, consistent with smooth operation, desired head contour, and good fusion. When used in other than the flat horizontal position, an electrode recommended for out of position welding, such as Inco Alloys International's Ni-Rod 55X, should be used. The welding current should be reduced 10 to 20 amps for vertical welding and 5 to 15 amps for overhead welding with Inco Alloys International's Ni-Rod 55X. The arc length should be kept as short as possible consistent with obtaining smooth operation and sufficient penetration and wash at the side of the joint. A slight weave of the electrode is recommended, although this should not exceed three times the diameter (i.e., corewire diameter) of the electrode. When mild-steel components are being joined to Ductile Iron pipe, the center line of the arc should be concentrated as far as possible onto the mild-steel component, which is thereby made to absorb as much heat as possible from the arc. The relatively low arc intensity associated with the nickel-iron electrodes, coupled with the sluggish metal-transfer characteristic, is conducive to minimum heat input, giving minimum fusion and minimum carbide formation in the base iron.

By depositing narrow beads in short lengths one can reduce the cumulative effect of the stresses from shrinkage of weld metal. Each length of bead should be allowed to cool until it can be touched by hand before another deposit is made within the area heated by the first bead. While one bead is cooling, others are deposited at other locations throughout the joint. All beads should be deposited in the same direction.

Another method to reduce shrinkage stresses is to peen a deposited bead of weld metal while it is still hot. Peening

*Figure 1* Shielded Metal-Arc Welding Process

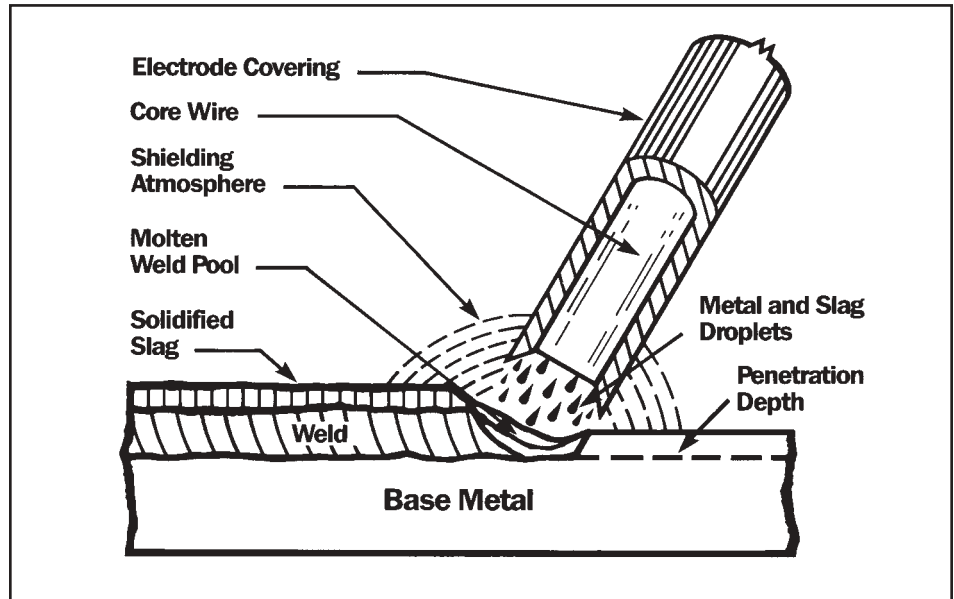

should be done with repeated moderate blows using a round-nose tool and sufficient force to deform the weld metal but without rupturing it. Effective peening stretches the weld metal to help compensate for the shrinkage that occurs during cooling. The peened metal is then allowed to cool before another bead is deposited near it.

By using a low welding current, a small-diameter electrode, and depositing multiple narrow beads, only the lower layer of weld metal has a very high carbon content. Subsequent layers of weld metal tend to temper and reduce hardness of the first layer.

Complete flux removal is essential after each weld pass before depositing further weld metal since entrapped slag can impair the strength properties of the weld. Flux removal, in the case of nickel-iron electrodes, can usually be easily accomplished with a pointed welder's hammer or by wire-brushing.

### Metal Inert Gas (MIG) Welding

Metal inert gas and pulsed-metal inert gas arc welding using argon or argon-helium shielding-gas with short-circuiting transfer is suitable for joining Ductile Iron to itself and to mild steel. Because of the relatively low heat input with this process, the hard portion of the heat-affected zone is usually confined to a thin layer next to the weld metal. As a result, the strength and ductility of the welded joint are about the same as those of the base metal.

### Recommended Filler Material

It has been established that the most satisfactory filler metal for MIG short-arc welding of Ductile Iron is nickel (ENi-1).

### Flux-Cored Wire Arc Welding

This process is similar to MIG welding insofar as a consumable wire electrode is used. However, whereas MIG welding uses an inert-gas shield to protect the weld pool, the flux-cored wire process

*Figure 2* Metal Inert Gas (MIG) Welding Process

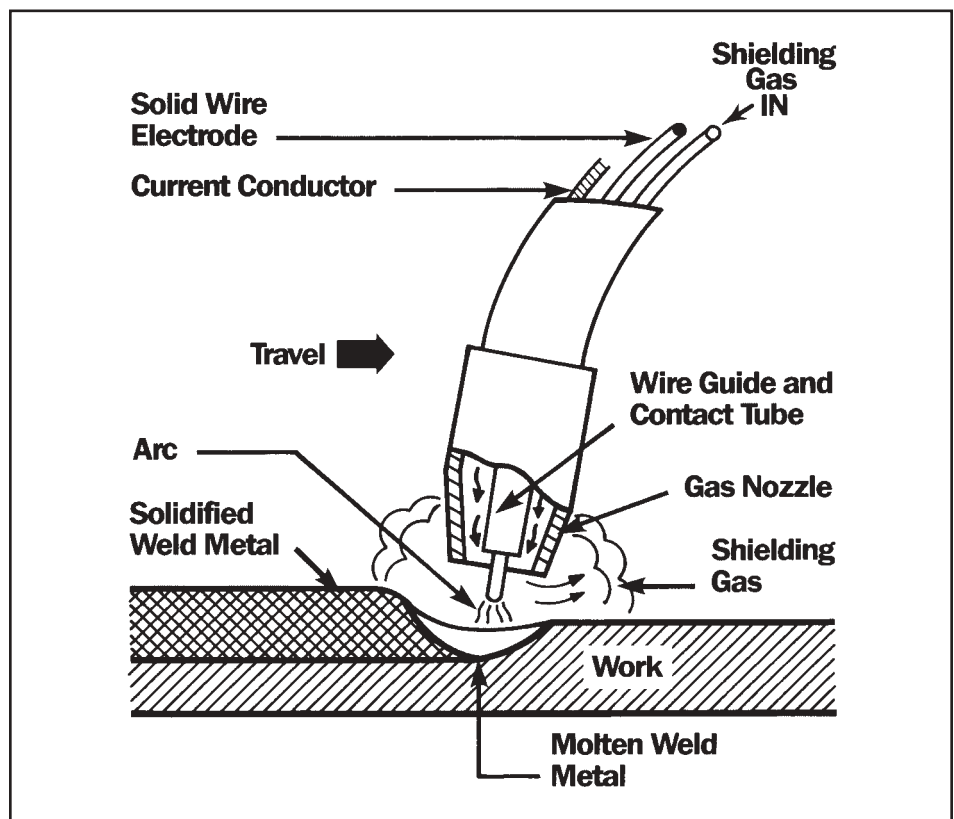

derives its protection from the slag formed from the flux materials contained in the core of the tubular wire. A Ni-Rod FC55 cored wire electrode is available that produces weld metal with a composition and micro-structure similar to that deposited by ENiFe-CI covered electrodes. The principle of graphite precipitation and the associated volume increase is the same for both electrodes.

The flux-cored electrode is a self-shielding design but it may be used with carbon dioxide (CO<sub>2</sub>) shielding or as a submerged arc welding electrode. The electrode producer should be consulted for recommendations on usage and procedures for specific applications.

### Oxyacetylene Welding

Oxyacetylene welding procedures require large amounts of heat input during both the pre-heating and the welding operations. The extensive heating is a limiting factor in the application of this process. The process is not considered suitable for fabrication work as the high heat input can cause excessive distortion; and in the as-deposited condition, the weld area is likely to contain a high proportion of iron carbide.

## Field Welding Procedure For Field-Cut Restrained Joint Ductile Iron Pipe

Many restrained joint designs rely on a welded-on retainer ring around the spigot of the pipe to provide part of the means of restraint. This retainer ring is furnished factory-welded in position on the pipe. The welding is performed by welders qualified to produce high-quality, dependable welds. By planning ahead, necessary field cuts of Ductile Iron pipe can normally be positioned in unrestrained

**Figure 3** Flux-Cored Wire Arc Welding Process

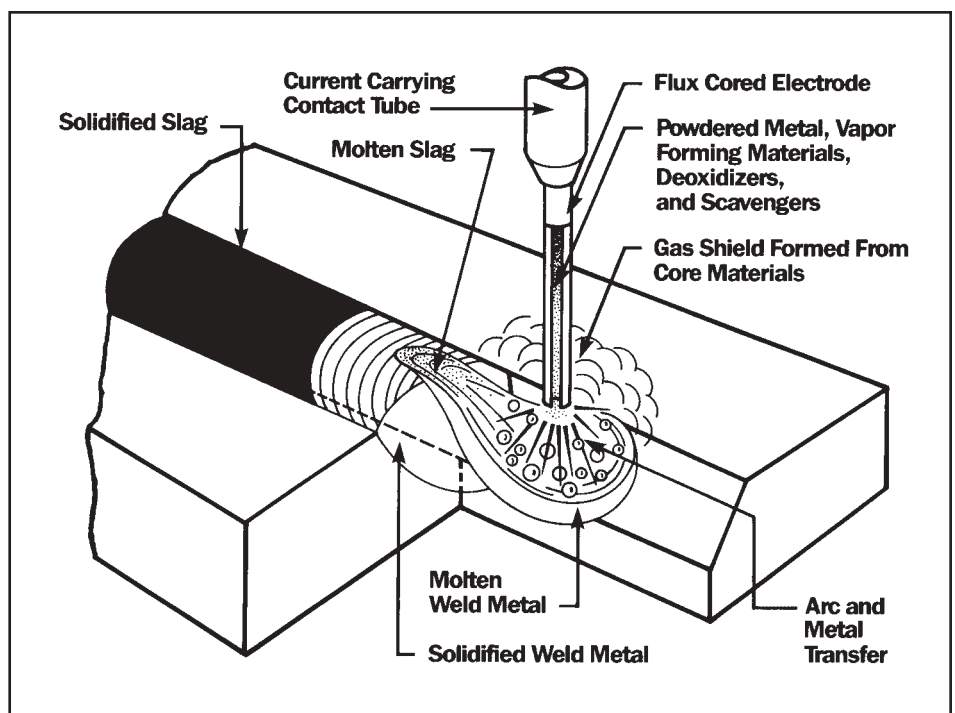

sections of the pipeline. However, if field cuts are required in restrained joint pipe sections utilizing the welded-on retainer ring, a loose factory-supplied ring can be field-welded onto the barrel of the field-cut Ductile Iron pipe.

Welds should be applied using a D.C. arc welder employing reversed polarity and operating at amperage ranges recommended by the electrode manufacturer. General ranges of amperages for

various diameter electrodes are shown in Table 1 below.

The weld electrodes used should be in conformance with Class designation AWS 5.15 (ENiFe-CI). Three such electrodes are Inco Alloys International's Ni-Rod 44, Ni-Rod 55 and 55X (consult pipe manufacturer for recommendations). The electrode and electrode diameter recommended by pipe manufacturers for their retainer ring should be used.

**Table 1** General Amperage Ranges for Various Electrodes

Electrode Diameter	Recommended Current (amp)
3/32-in.	40-65
1/8-in.	75-95
5/32-in.	100-135
3/16-in.	120-155



**Step 1.** Measure the pipe diameter (or circumference) at the location of the cut to ensure that it is within the tolerance shown in Table 2 on page 11 of this brochure.



**Step 2.** Mark the pipe at sufficient intervals around the circumference by measuring from a reference — usually the spigot end of the pipe.



**Step 3.** Cut the pipe at the desired location. Following the cut, the outside of the cut end should be beveled smooth per the manufacturer's recommendations.

## Procedure

1. Measure the candidate pipe diameter (or circumference) at the location of the cut to be made to ensure that the pipe diameter and circumference are within the tolerance shown in Table 2. (Note: There are minimum laying lengths for restrained joint pipe. Consult manufacturer.)
2. Mark the pipe at sufficient intervals around the circumference by measuring from a reference (usually the spigot end) such that a square cut can be made.
3. Cut the pipe at the desired location. It is important that field cuts for restrained joint welding be smooth, regular, and as square as possible with the axis of the pipe because the cut end will be used as a reference to position the retainer ring. The outside of the cut end should be beveled smooth per the manufacturer's recommendations using a grinder or file to prevent damage to the gasket during assembly.
4. Mark the location of the weld-on retainer ring from the cut end of the pipe per the manufacturer's specifications.
5. Remove the asphaltic coating on the pipe in the area the retainer ring is to be welded with a solvent wash or by burning with a torch. After the asphaltic coating has been removed, grind the retainer ring location to bright metal. Also, the corresponding edge of the ring to be welded should be cleaned and ground to bright metal. Place loose locking rings or glands (if required for the particular joint



**Step 4. Mark the location of the weld-on retainer ring from the cut end of the pipe per the manufacturer's specifications.**



**Step 5. Remove the pipe's asphaltic coating on the area where the retainer ring will be welded with a solvent wash or by burning with a torch; then grind the retainer location to bright metal.**



**Step 8. Clamp the weld-on retainer ring securely on the pipe in the correct location.\* If the clamping device bears on the inside of the pipe, take care to minimize damage to the pipe lining.**

configuration) on the pipe barrel beyond the retainer ring location.

6. Re-mark the location of the weld-on retainer ring on the pipe as was done in Step 4.
7. Some restrained joint designs require the weld-on retainer ring to be cut to length in the field. If such is employed, fit the ring around the pipe and mark and cut the ring to the length recommended by the manufacturer. Normally the ring will be cut "short" to accommodate lengthening during the welding operation.
8. Clamp the weld-on retainer ring securely on the pipe in the correct location.\* This may be accomplished using the manufacturer's special welding jigs, fixtures, and/or C-clamps. If the clamping device bears on the inside of the pipe, care should be taken to minimize damage to the pipe lining. If welding fixtures and/or C-clamps are used, the weld deposit should be applied in circumferential intervals corresponding to the movement of the clamps as recommended by the pipe manufacturer.
9. With the retainer ring fitted closely to the pipe surface, weld on the side of the ring next to the cut end of the pipe.\* Weld according to the pipe manufacturer's recommendations (electrode diameter, weld size, weld passes required,

\*The configuration of rings varies slightly from manufacturer to manufacturer. Contact your DIPRA member company regarding the ring configuration it recommends.





**Step 9.** With the retainer ring fitted closely to the pipe surface, weld on the side of the ring next to the cut end of the pipe according to the manufacturer's recommendations.\* (Skip welding techniques can be used.) After the entire ring has been welded to the pipe, weld the ring ends to the pipe and weld in the space remaining between the ring ends.



**Step 10.** Thoroughly clean the weld and ring\* to remove all weld flux and splatter so the pipe spigot is clean for proper gasket sealing and joint assembly.



**Step 11.** Coat the ring\*, weld, and ground pipe surface with a smooth uniform coat of brushable mastic.

welding technique, etc). To minimize heat build-up that may possibly cause thermal stresses and/or damage to linings, skip welding techniques can be used. Thorough peening of the weld passes before they cool will minimize thermal stresses. The ends of adjoining passes should be slightly overlapped before the arc is broken. If weld cracks occur, they should be ground away and repaired with a weld overlay. After the entire ring has been welded to the pipe, weld the ring ends to the pipe and weld in the space remaining between the ring ends according to the pipe manufacturer's instructions.

10. Thoroughly clean the weld and ring\* to remove all weld flux and splatter. The pipe spigot should be clean of weld splatter for proper gasket sealing and joint assembly.
11. Coat the ring\* weld and ground pipe surface with a smooth uniform coat of brushable mastic.
12. Inspect the pipe lining for possible damage. Cement-mortar linings are normally not adversely affected by such welding procedures; however, if cement lining damage occurs, it should be patched in accordance with recommended procedures as noted in ANSI/AWWA C104/A21.4 Standard, "Cement-Mortar Linings for Ductile-Iron Pipe and Fittings for Water." Contact the pipe manufacturer for repair of special linings.

\*The configuration of rings varies slightly from manufacturer to manufacturer. Contact your DIPRA member company regarding the ring configuration it recommends.

### Cutting Ductile Iron Pipe

Ductile Iron pipe may be cut using an abrasive pipe saw, a rotary wheel cutter, a guillotine pipe saw, or a milling wheel saw. Cement-mortar-lined or unlined Ductile Iron pipe can also be cut with an oxyacetylene torch if recommended by the pipe manufacturer for its product.

The ANSI/AWWA standard for Ductile Iron pipe requires factory gauging of the spigot end. Accordingly, pipes selected for cutting should be field-gauged in the location of the cut and be within tolerance as shown in Table 2.

Torch cutting of Ductile Iron pipe normally results in a heat-affected zone extending less than 1/4-inch from the cut face but might result in small cracks in this area which should be removed by grinding. Some difficulty might result in threading or machining in this particular portion of the pipe due to hardening of the metal. Such hardening does not interfere with push-on or mechanical joint assembly or performance.

Pipe manufacturers who recommend torch cutting of their pipe report best results are obtained by using a No. 8 or No. 10 tip with approximately 75 psi oxygen and 10 to 15 psi acetylene. For cement-lined Ductile Iron pipe, the best results are normally obtained when the torch head is inclined approximately 60 degrees to the direction of cutting. Cutting time for pipe cut by oxyacetylene methods is approximately one minute per inch of diameter for cement-lined pipe and even less for unlined pipe.

Cut ends and rough edges should be ground smooth and for push-on connections, the cut end should be beveled to the approximate profile of the factory supplied end.



**In addition to being cut with an abrasive pipe saw, a rotary wheel cutter, a guillotine pipe saw, or a milling saw, Ductile Iron pipe can also be cut with an oxyacetylene torch if recommended by the pipe manufacturer. Cut ends and rough edges should be ground smooth. For push-on connections, the cut end should be beveled to the approximate profile of the factory supplied end.**

**Table 2**

Suitable Pipe Diameters for Field Cuts and Restrained Joint Field Fabrication

Nominal Pipe Size In.	Min. Pipe Diameter In.	Max. Pipe Diameter In.	Min. Pipe Circumference In.	Max. Pipe Circumference In.
4	4.74	4.86	14 29/32	15 9/32
6	6.84	6.96	21 1/2	21 7/8
8	8.99	9.11	28 1/4	28 5/8
10	11.04	11.16	34 11/16	35 1/16
12	13.14	13.26	41 9/32	41 21/32
14	15.22	15.35	47 13/16	48 7/32
16	17.32	17.45	54 13/32	54 13/16
18	19.42	19.55	61	61 13/32
20	21.52	21.65	67 19/32	68
24	25.72	25.85	80 13/16	81 7/32
30	31.94	32.08	100 11/32	100 25/32
36	38.24	38.38	120 1/8	120 9/16
42	44.44	44.58	139 5/8	140 1/16
48	50.74	50.88	159 13/32	159 27/32
54	57.46	57.60	180 17/32	180 31/32
60	61.51	61.65	193 1/4	193 11/16
64	65.57	65.71	206	206 7/16
Above table based on ANSI/AWWA C151/A21.51 guidelines for push-on joints				

## References

1. American Cast Iron Pipe Company, "Instructions for Field Welding of American Restrained Ductile Iron Pipe Joints."
2. ANSI/AWS D11.2 Standard, "Guide for Welding Iron Castings," 1989.
3. ANSI/AWS A5.15 Standard, "Specification for Welding Electrodes and Rods for Cast Iron."
4. ANSI/AWWA C151/A21.51 Standard, "Ductile-Iron Pipe, Centrifugally Cast, for Water."
5. British Cast Iron Research Association, "The Joining and Fabrication of Nodular Iron Castings by Welding," 1982.
6. INCO Alloys International, Ni-Rod 44 and Ni-Rod 55 Welding Electrodes.
7. INCO Alloys International, Ni-Rod 99X and Ni-Rod 55X Welding Electrodes.
8. Jefferson, T.B., "Metals and How to Weld Them," Second Edition, Welding Engineer Publication, Inc.
9. The Lincoln Electric Company, "The Procedure Handbook of Arc Welding," Twelfth Edition.
10. U.S. Pipe and Foundry Company, "Field Cutting and Welding Procedure for TR FLEX Pipe," 1997 Edition.



---

# DIPRA MEMBER COMPANIES

American Cast Iron Pipe Company  
P.O. Box 2727  
Birmingham, Alabama 35202-2727

Atlantic States Cast Iron Pipe Company  
183 Sitgreaves Street  
Phillipsburg, New Jersey 08865-3000

Canada Pipe Company, Ltd.  
1757 Burlington Street East  
Hamilton, Ontario L8N 3R5 Canada

Clow Water Systems Company  
P.O. Box 6001  
Coshocton, Ohio 43812-6001

Griffin Pipe Products Company  
1400 Opus Place, Suite 700  
Downers Grove, Illinois 60515-5707

McWane Cast Iron Pipe Company  
1201 Vanderbilt Road  
Birmingham, Alabama 35234

Pacific States Cast Iron Pipe Company  
P.O. Box 1219  
Provo, Utah 84603-1219

United States Pipe and Foundry Company  
P.O. Box 10406  
Birmingham, Alabama 35202-0406

## DUCTILE IRON PIPE RESEARCH ASSOCIATION



An association of quality producers dedicated to highest pipe standards through a program of continuing research.  
245 Riverchase Parkway East, Suite O  
Birmingham, Alabama 35244-1856  
Telephone 205 402-8700 FAX 205 402-8730  
<http://www.dipra.org>

## DUCTILE IRON PIPE THE RIGHT DECISION



Manufactured from recycled materials.