

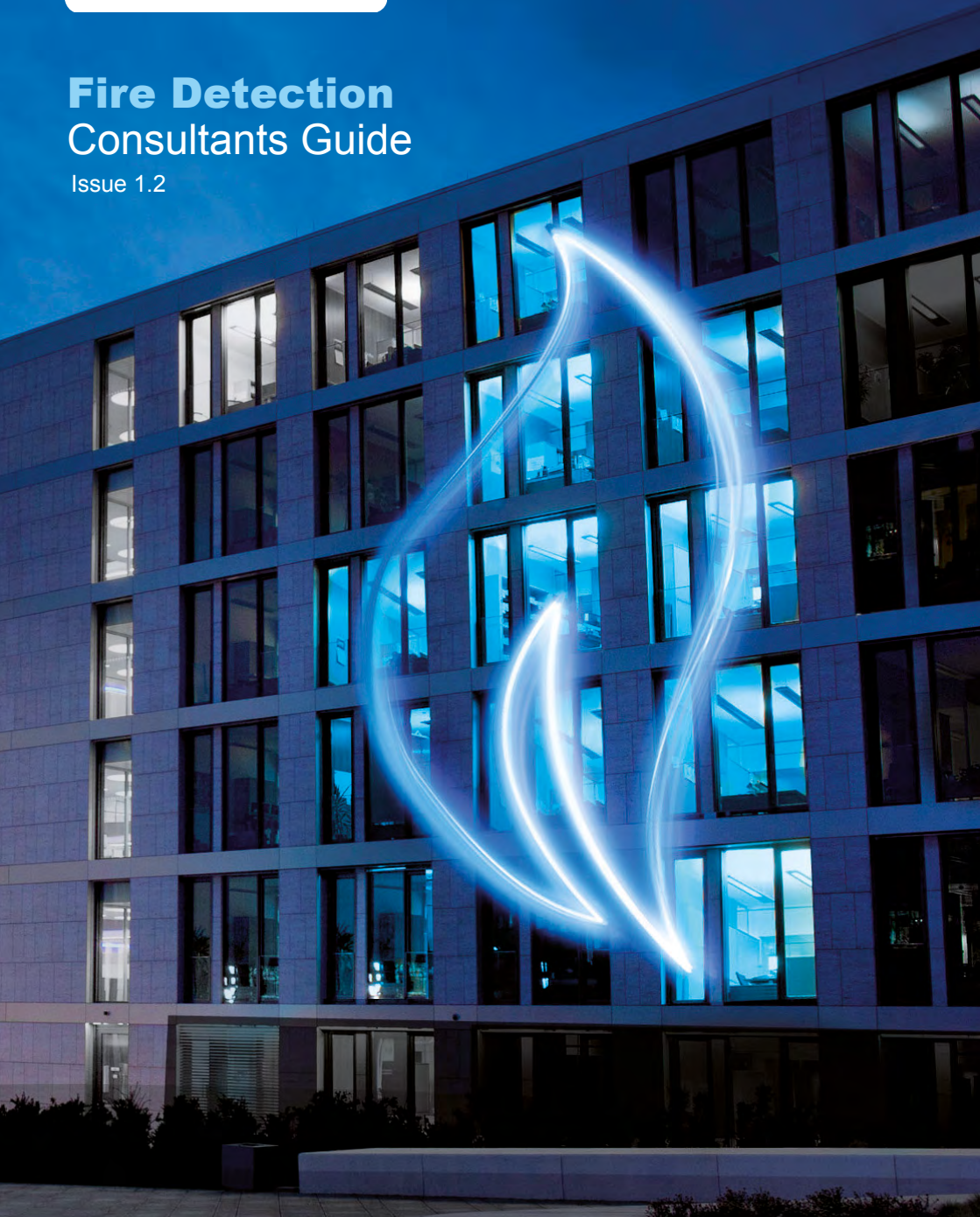

Fire Detection Consultants Guide

Issue 1.2





section one | guide to design, installation, commissioning and maintenance of fire systems in non domestic premises

contents

About this manual	Purpose	1
	Readership	3
	Electronic Format	4
	Acknowledgments	4
Section One: Guide to Design of Fire Systems		
1.	Introduction	7
1.1	Planning the System	10
1.1.1	The role of fire risk assessment and fire engineering	11
1.1.2	Variations from BS 5839-1	12
1.1.3	Type of system	13
1.1.4	Servicing arrangements	13
1.1.5	Planning flowchart	16
2.	Selecting the category of protection and coverage	17
2.1	Category M – manual	18
2.2	Category L5 – life	18
2.3	Category L4 – life	19
2.4	Category L3 – life	19
2.5	Category L2 – life	20
2.6	Category L1 – life	21
2.7	Category P2 – property	21
2.8	Category P1 – property	22
3.	Detector zones and alarm zones	23
3.1	The meaning of a detection zone and alarm zone	23
3.2	The purpose of detection zones	23

contents

3.3	Detection zone configuration guidelines	24
3..4	Detection zone safeguards	25
4	Which type of fire detection and alarm system?	29
4.1	Conventional systems	29
4.1.1	Detection zones	29
4.1.2	Detectors and call points	30
4.2	Addressable systems	30
4.2.1	Operation of addressable systems	31
4.2.2	Detectors and call points	31
4.2.3	Output devices	33
4.3	Digital addressable systems	34
4.3.1	Operation of analogue addressable detectors	34
4.3.1.1	Detector pre-alarm warning	36
4.3.1.2	Detector alarm threshold compensation	37
4.3.1.3	Detector condition monitoring	38
4.3.1.4	Detector sensitivity setting	39
5.	Detector suitability	41
5.1	General fire system engineering principles	41
5.2	Detector selection for a particular area	43
5.2.1	Smoke detectors	43
5.2.2	Heat detectors	44
5.2.3	Heat-enhanced Carbon monoxide fire detectors	47
5.2.4	Flame detectors	49
5.2.5	Optical beam detectors	52
5.2.6	Aspirating detectors	56
5.2.7	Duct probe unit	58
6.	Detector coverage	60
6.1	Spacing under flat ceilings	60
6.2	Spacing under pitched ceilings	62
6.3	Spacing in corridors	63
6.4	Stairways	63
6.5	Lift shafts and other flue-like structures	64
6.6	Obstructions	64

contents

6.7	Honeycomb ceilings	66
6.8	Closely spaced structural beams and floor joists	67
6.9	Ceiling heights	69
6.10	Walls and partitions	71
6.11	Voids	71
6.12	Perforated ceilings	72
6.13	Ventilation	72
6.14	Lantern-lights	73
7.	Manual “break glass” call points	74
7.1	General information	74
7.2	Siting of manual call points	74
8.	Limitation of false alarms	77
8.1	Role of the designer	77
8.2	Categories of false alarm	80
8.3	Requirements for service technicians	80
8.4	False alarm ‘rates’	81
8.5	Causes of false alarms	84
8.6	Practical measures to limit false alarms	85
8.6.1	Siting and selection of manual call points	86
8.6.2	Selection and siting of automatic fire detectors	87
8.6.3	Selection of system type	89
8.6.4	Protection against electromagnetic interference	90
8.6.5	Performance monitoring of newly commissioned systems	91
8.6.6	Filtering measures	92
8.6.7	System management	96
8.6.8	Servicing and maintenance	97
8.6.9	New non compliances	97
9.	Means of giving warning to occupants	98
9.1	Sound pressure level	98
9.2	Discrimination and frequency	101
9.3	Sound continuity	101
9.4	Audible alarms in noisy areas	101
9.5	Alarm zones	102
9.6	External fire alarm devices	103

contents

9.7	Voice alarm systems and voice sounders	103
9.8	Fire alarm warnings for deaf people	104
10.	Control and indicating equipment	105
10.1	Siting of control and indicating equipment	105
10.2	Location of origin of the fire	106
10.3	Security of control equipment	106
10.4	Networked control panels	107
11.	Power supplies	108
11.1	Mains supply	108
11.2	Standby supply	109
11.2.1	Life protection (category M and L systems)	109
11.2.2	Property protection (category P systems)	110
11.2.3	Calculation of standby battery capacity	110
12.	Cabling considerations	113
12.1	Recommended cable types	113
12.2	Cable suitability	114
12.3	Conductor sizes	117
12.4	Segregation	117
12.5	Cable colour coding	118
12.6	Joints in cables	119
12.7	Cable support	119
12.8	Mechanical protection of cables	120
13.	Communication with the fire service	121
13.1	Automatic transmission of alarm signals	121
13.1.1	Category L systems	122
13.1.2	Category P systems	123
13.2	Methods of automatic transmission	123
13.3	Standards for Alarm Receiving Centres (ARCs)	123

section one | guide to design, installation, commissioning and maintenance of fire systems in non domestic premises

contents

14.	System installation	124
14.1	Siting of equipment	125
14.2	Installation work	125
14.3	Inspection and testing	126
14.4	Commissioning and handover	127
15.	Documentation	131
16.	Maintenance	133
16.1	Routine testing	133
16.2	Servicing	134
17.	Responsibilities of user	136

contents

Section Two:

Introduction	141
Control and Indicating equipment	151
Fire alarm devices - sounders	156
Power supply equipment	161
Heat detectors - point detectors	166
Smoke detectors	173
Flame detectors	178
Manual call points	182
Smoke detectors - line type	188
Compatibility assessment of system components	192
Voice alarm control and indicating equipment	195
Short circuit isolators	201
Input /output devices	205
Aspirating smoke detectors	208
Alarm transmission and fault warning routing equipment	214
Fire alarm devices - visual alarm devices	218
Components of voice alarm systems - loudspeakers	224
Components using radio links	229
Carbon monoxide detectors - point detectors	232
Multi sensor fire detectors - point detectors using both smoke and heat detection	238
Multi- sensor fire detectors point detectors using a combination of carbon monoxide and heat sensors	243
Multi- sensor fire detectors - point detectors using a combination of smoke, carbon monoxide and heat sensors	250
Electrical apparatus for potentially explosive atmospheres	257
Intrinsic safety "I"	
Fixed firefighting systems - components for gas extinguishing systems	263

about this manual

Purpose

The Code of Practice for fire detection and alarm systems for buildings (BS 5839- 1) is a detailed and comprehensive document which requires careful reading to fully understand its' requirements and latest approach to ensuring the safety of buildings and their occupants from the ever present threat of fire.

The purpose of this manual is to provide a step-by-step approach to the necessary guidelines described in BS 5839-1, so that users can achieve maximum benefit from the recommendations. This should assist in the task of choosing the best options, help in preparing the specification of the fire protection system and assist architects, designers and electrical engineers in providing the most cost effective system solution that meets the needs of the user.

This manual is a consultants guide to the contents and usage of the British Standard Code for the design, installation and maintenance of fire detection and alarm systems for buildings (BS 5839-1). Throughout the manual, where it was necessary to reference this long title, we will simply refer to it as 'the Code'.

The Code is divided into seven sections. The first section is intended to be of general interest to all users, the second is intended to be of interest to the system designer, architect or electrical engineer. The third section attempts to address one of the major problems plaguing fire detection systems in Britain today, that of false and unwanted alarms. This section offers advice and best practices for the successful management of false alarms. The fourth section is for the installer with a link to section five which covers commissioning and handover of the system. Section

about this manual

six recognises the importance of good planned maintenance and the seventh section is for the user. Each section contains commentary followed by recommendations. It is the recommendations that are used to audit a system.

In practice, more than one organisation or company is usually involved in the design of the system and its installation. The Code recognises these different responsibilities and takes a modular approach to the process of contracting when installing a fire alarm system. Furthermore, the Code recognises that, in most cases, the user is unlikely to buy a copy of the Code in order to learn about his responsibilities. In fact, the Code recommends that the installer should instruct the user on his responsibilities.

It is often a requirement that individual organisations or individual persons need to be familiar with all aspects of the Code. In this manual, therefore, we

follow through the design phase, the installation phase and use of the system phase without strictly following the Code as sectionalised.

This manual is a guideline to the Code only and as such it is important to read this manual in conjunction with the Code so that all aspects can be fully understood.

This manual is not a replacement for the Code.

The manual consists of two sections.

Section 1: Guide to Design of Fire Systems

This section contains information taken from the planning and design guidelines described in BS 5839-1.

section one | guide to design, installation, commissioning and maintenance of fire systems in non domestic premises

about this manual

Section 2: An introduction to the suite of EN54 standards

This section contains an overview of all relevant EN54 standards in common usage throughout the UK fire manufacturing and buyers base.

EN54 standards are common across European member states and exist to provide test criteria for the vigorous and comprehensive functionality and performance testing of critical life safety / property protection products, used in the design and installation of fire detection and alarm systems.

Such products are regulated by this set of standards referenced EN54 and these standards are harmonised, which means they become law under the Construction Products Regulation (CPR). Proof of compliance is by CE marking.

The aim of Section 2 is to provide an overview of each of the current harmonised standards.

Approvals, whilst being mandatory within the EU also proves reliability and longevity as well as sensitivity which together are some of the most essential components of both life safety and property protection systems.

Readership

This manual has been prepared for use by architects, designers and electrical engineers responsible for the design, specification and installation of fire protection and alarm systems intended for use in medium to large size buildings, for example, schools, hotels, hospitals, office complexes, shopping precincts, supermarket stores, airports, warehouses, etc.

contents

The information provided herein is intended specifically for the use of appropriately qualified and experienced persons as stipulated in the Foreword to BS 5839-1.

Electronic Format

This document is available for download in PDF format. Section 2 of this manual is a sample specification for digital addressable fire detection systems, which is also downloadable in Word format from www.tycoemea.com

Acknowledgements

We gratefully acknowledges the use of certain extracts taken from the Code and thanks the British Standards Institution for allowing the use of some of its material.



Section one

Guide to design installation, commissioning and maintenance of fire systems

introduction

1. Introduction

Fire detection and alarm systems are designed to provide warning to the outbreak of fire, so allowing evacuation and appropriate fire fighting action to be taken before the situation gets out of control. Systems may be designed primarily to protect property or life, or to protect against interruption to a client's business from fire; some systems may be designed to achieve any combination of these objectives. It is essential that the designer understands the objective(s) of the system. This places a great responsibility on the designer because each building will present a different set of problems in relation to satisfying the objective. Each fire detection and alarm system therefore must be specifically designed to meet the requirements of the client for each building.

Once the objective(s) has been defined, in designing a system, particular consideration must be given to the type of building, its construction and the purpose for which it is being used, so that in the event of a fire, the fire detection system, combined with appropriate fire prevention procedures, will keep fire risk to a minimum.

The information provided herein is intended to help and enable appropriately qua-

lified designers to plan and design fire detection and alarm systems suitable for use in any type of building or installation.

As mentioned above, the designer of a fire detection and alarm system bears a great responsibility because the safety of personnel, property and the continuing operation of the business rests with him. Occasionally, particular problems may occur which are not covered in this manual. In such cases it is most important that you seek specialist advice at an early stage.

When designing a fire detection and alarm system, in addition to deciding the type of system, detectors, call points and sounders to be used etc., there are also other aspects which need to be considered. These include measures to limit false and unwanted alarms, method of installation, materials required during installation, user training, routine maintenance procedures, and service agreement. For any system to function reliably and provide problem free service throughout the life of the system, all of these aspects must be considered in the overall system design and plan.

What is the BAFE Modular Scheme?

The British Approvals for Fire Equipment (BAFE) modular scheme, SP203, was

introduction

launched in 2002 and has been prepared for the third party certification of companies involved in the:

- Design
- Installation
- Commissioning and handover
- Maintenance of fire detection and alarm systems and/or fixed fire suppression systems.

The scheme has four modules in recognition of the fact that a different company may undertake each module. Thus, for example, a consulting engineer can be certificated under the scheme for design of fire detection and alarm systems, whereas fire alarm contractors will normally be certificated for all four modules. An electrical contractor, on the other hand, could be certificated purely for the installation module. The scheme is, therefore, designed to reflect the way in which fire alarm contracts actually operate, and it parallels BS 5839-1, which is divided into separate sections containing recommendations for design, installation, commissioning/ handover and maintenance.

A BAFE certificate of compliance is issued to the completed system, provided firms certificated under the scheme have been responsible for, and issued certificates for,

design, installation and commissioning. Before the BAFE certificate of compliance can be issued, however, an additional process, known as 'verification', must be carried out. This essentially ensures that the design drawn up at the beginning of the process remains valid at the end of the process.

What is LPS 1014?

LPS 1014 is a standard against which the Loss Prevention Certification Board (LPCB) assesses the ability of companies to design, install, commission and service fire detection and alarm systems.

This scheme has also been adopted by BAFE.

By specifying a company which is certificated to LPS 1014, you can be confident that your fire detection and alarm system will be installed competently to the codes of practice that you specify (e.g. BS 5839-1) and that the company can provide the necessary maintenance service required to maintain a valid LPS 1014 Certificate of Conformity.

For a company to be LPS 1014 Certificated it must fulfil the following requirements:

introduction

- Have two years continuous experience in design, installation, commissioning and servicing of systems.
- Have randomly selected installations inspected by the LPCB every six months against the specified contract requirements. Certificates must reliably identify any variations from the Installation Rules applied.
- Have the resources to support systems in case of a break down with 8-hour emergency call out service.
- Be competently capable of performing the planned servicing of installations.
- Have suitably trained and experienced staff.
- Operate a BS EN ISO 9000 quality system.

When an LPS 1014 approved company completes each installation contract, the client is issued with a Certificate of Conformity. Copies of these certificates are also forwarded to the LPCB. The LPCB use their copies of the certificates to choose randomly which installations to inspect.

An installation designed, installed, commissioned and maintained by a firm certificated under LPS 1014 will be likely to meet the statutory requirements of the fire brigade and satisfy your insurance com-

pany, provided their requirements have been taken into account in the design.

Environmental Issues :

Restriction on the use of Hazardous materials, (RoHS)

From 2014 RoHS is mandatory and a level set which manufacturers will not be able to exceed. Those seeking to install systems or specify a particular manufacturers systems and products should satisfy themselves that these requirements are met.

Registration, Evaluation, Authorisation and Restriction of Chemicals, (REACH)

This is an EU Regulation of December 2006 which addresses the production and use of chemical substances and their potential impacts on health and the environment. Key dates for compliance, based upon tonnage manufactured or imported were 2010, 2013 and going forward 2018. Manufacturers and suppliers should be able to demonstrate compliance when requested.

introduction

Inventory of Hazardous Materials (Green Passport)

Green passport is a marine requirement which was introduced to ensure that all materials used in the construction of a ship are safe. Despite this any materials which are confirmed as safe will provide the same green benefits to all parties, manufacturers, installers, maintainers and users irrespective of whether the system is installed on dry land or in a marine environment. An inventory of Hazardous materials is a list of hazardous materials, waste and stores. Once the IHM has been developed a Statement of Compliance is required. SOC or Green passport as it is known is a self certification process.

Products should be independently assessed in order to ensure compliance and to support the issuing of a Green passport. The use of safe "Green Passport certified" products are to be encouraged in all situations.

1.1 Planning the System

This task is probably the most important of all because mistakes made here may have a fundamental effect on the category and operation of fire detection and alarm system. The specification and

associated documentation which form the invitation to tender will indicate any weaknesses, errors or omissions in the design. The specification of the system therefore should be prepared with great care, thus ensuring that all requirements of the system are covered.

Clause 6 of BS 5839-1 defines the responsibilities of the designer of the system, particularly in terms of exchange of information and consultation with other parties.

The key parties with whom the designer needs to consult are the user or purchaser of the system and any relevant consultants, including architects, M&E consultants and fire engineering consultants.

Before design begins, the designer should ensure that he understands the objectives of the system. Is it merely to satisfy legislative requirements for the protection of life? Instead, or in addition, is it to protect property, perhaps in order to satisfy insurers' requirements? Is it intended to minimize disruption to the business in the event of fire? It is the responsibility of the user or purchaser of the system (or a consultant acting on their behalf) to consult with the relevant enforcing authorities (e.g. building control and the fire authority)

introduction

and, where relevant, the insurers to determine their requirements. These requirements should then be passed on to the designer. Where the designer is in any doubt, he should endeavour to clarify the requirements by discussion with the user or purchaser, and he should make clear to the client the nature and objectives of the protection that he proposes to design.

The design of the system should be 'driven' by the fire safety strategy for the building, including the required evacuation procedures. For example, to support the procedures, a two-stage alarm might be necessary. It is too late to develop fire procedures once the system has been designed. The designer needs to understand the client's intended fire procedures to ensure that these can be supported by the system. On the other hand, at the time of initial design, sufficient information is not always available. In such cases, the consultant may need to leave some flexibility for amendment of the design to suit the final procedures and the particular system that is supplied.

1.1.1 The Role of Fire Risk Assessment and Fire Engineering

The Regulatory Reform (Fire Safety) order 2005, introduced in October 2006, sim-

plified the law on fire safety by replacing over 70 separate pieces of fire safety legislation. The order now placed those responsible for fire safety in business ('responsible persons') to carry out a fire risk assessment, and the findings must be documented if the employer employs five or more employees. This requirement applies even if the premises have been accepted by enforcing authorities under other fire safety legislation, such as the Fire Precautions Act. The 'Responsible Person' needs to identify the fire precautions that should be taken by means of a fire risk assessment. The designer of a fire alarm system for an existing building needs to be aware of any relevant findings of the fire risk assessment.

Most buildings will need a manual fire alarm system to protect occupants. Where people sleep in the building, comprehensive coverage by fire detection will also be necessary. The fire risk assessment might also identify the need for fire detection in specified areas of a building in which no one sleeps. Sometimes, the fire detection is necessary to compensate for shortcomings in other fire precautions, in which case the fire risk assessment should identify the level of coverage required.

The fire precautions, such as means of escape, in many complex modern buildings

introduction

do not necessarily follow the guidance in traditional 'prescriptive' codes of practice. Instead, a 'fire engineering solution' is adopted, whereby a package of integrated fire protection measures achieve a standard of fire safety that is, at least, equivalent to the safety offered by the prescriptive code. Often, automatic fire detection is one of the measures included in the package. The designer of the fire alarm system should take great care, in this case, to ensure that the system meets the needs of the fire engineering solution. This might necessitate consultation with the fire engineer responsible for the fire engineering solution.

1.1.2 Variations from BS 5839-1

BS 5839-1 is a code of practice, rather than a rigid standard. It contains recommendations that will be suitable in most circumstances, rather than inflexible requirements. This means that the consultant may adopt 'variations' from the recommendations of the code to suit the particular needs of the building.

This does not mean that the recommendations should be ignored. They should always be considered and, normally, followed. However, the designer might adopt a variation on the basis of a fire risk assessment or his engineering judgement, practical considerations arising from insta-

llation difficulties, to achieve a cost effective design, etc. A variation could be as simple as a small departure from some dimension specified in the code (e.g. maximum distance of travel to the nearest manual call point) or as significant as the omission of fire detectors from an area that is judged to be of such low hazard as to make fire detection unnecessary.

Care should be taken to ensure that the recommendations of the code regarding variations are followed exactly. The specific recommendations in question are that:

- The variations should be clearly identified, so that they are obvious to all interested parties, such as the user, purchaser, enforcing authority or insurer.
- Any variations identified or proposed during the installation or commissioning of the system, but not at the design stage, should be documented for subsequent agreement, as described above.
- The variations should be agreed by all the interested parties.

All variations should be listed in the design certificate that is issued by the consultant.

introduction

1.1.3 Type of System

Early in the planning of the system, the consultant needs to consider what type of system is appropriate. For example, consideration should be given to whether the system should be conventional or digital addressable. The two types of system are compared and contrasted in Section 4. As a general rule, conventional systems are appropriate only in buildings of limited size and complexity, where a simple indication of the zone in which there is a fire will be sufficient. In other buildings, an indication of the exact location of the detector(s) that has responded to a fire, provided by an addressable system, will be of value.

Digital addressable systems are recognised as having a lower potential for false and unwanted alarms than conventional systems. The code recommends that systems with a high number of smoke detectors (e.g. more than 100 detectors) should be of the digital addressable type.

Early consideration of the type of detectors to be used will also be needed. Heat detectors will be the most immune to false and unwanted alarms in most circumstances, but will not generally provide as early a warning of fire as smoke detectors or multisensor fire detectors. In some circumstances, multisensor fire detectors

can provide early warning of fire with less potential for false and unwanted alarms than smoke detectors. Flame detectors may be appropriate for special risks, such as areas in which there are flammable liquids.

1.1.4 Servicing Arrangements

Servicing arrangements are important because they represent a hidden cost to the user. Some systems may require regular attendance by a service engineer in order to maintain the system at a high efficiency level. Not only does the engineer have to be paid for, but his presence may also cause disruption to the day-to-day operation of the business. The latter element may actually be much more important to the end user than the service cost.

Section 6 of the code specifies recommendations for maintenance. This includes weekly tests and periodic inspection and servicing. Clause 45.3 states that, if some of the functions are tested automatically then the manufacturer can specify that some periodic testing can be omitted. This can pay off in servicing requirements since the end user can see the financial advantages of such a system. It should be noted that, if servicing requirements are included, it means that the quotation should also include the costs of the recommended system maintenance.

introduction

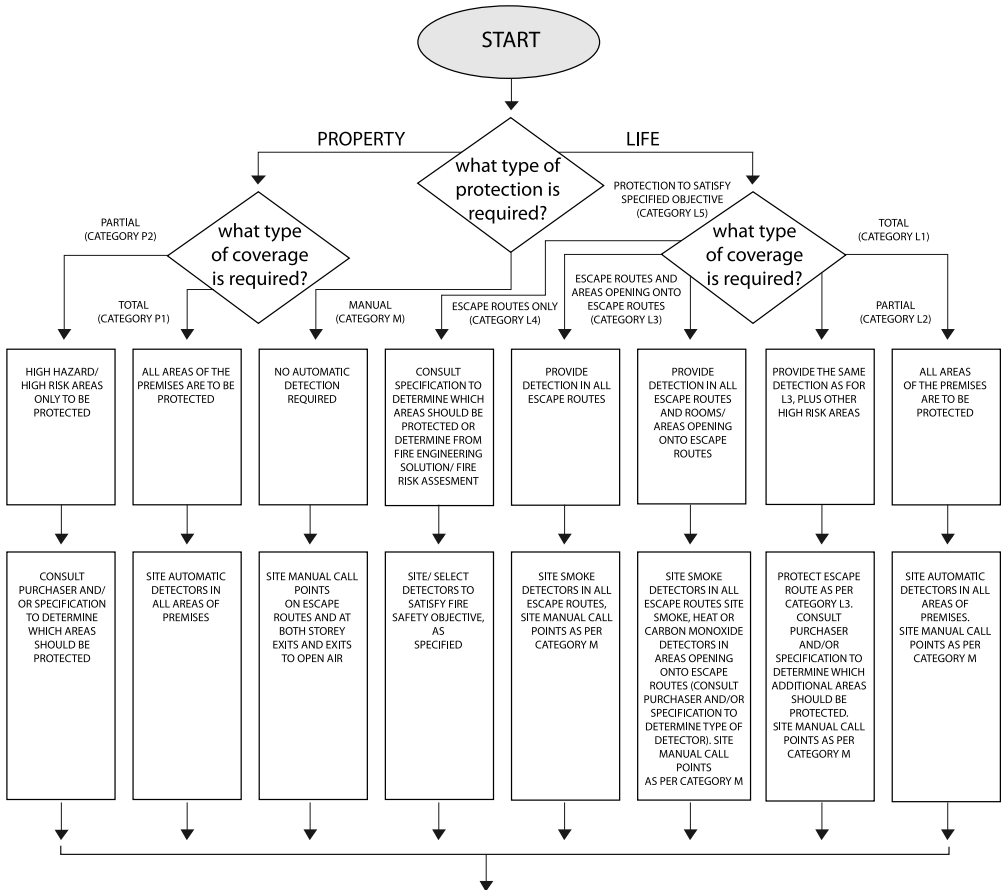

fig 1. Fire Planning and Design Flowchart (section1)

section one | guide to design, installation, commissioning and maintenance of fire systems in non domestic premises

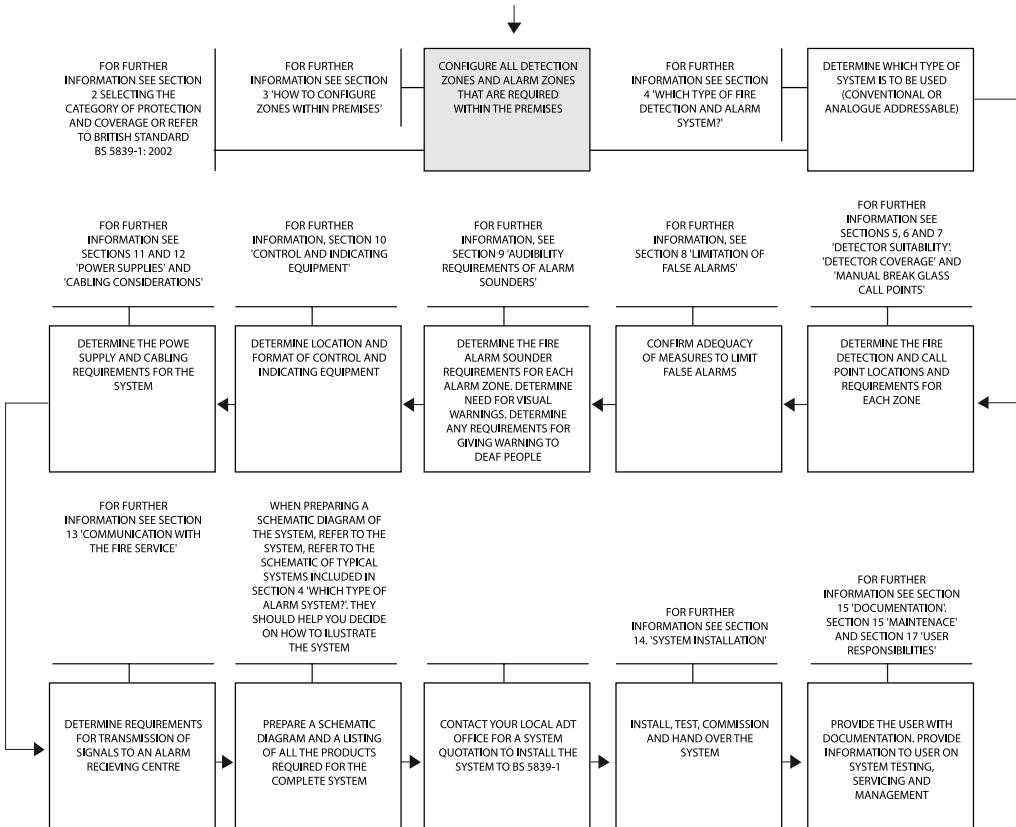

fig 1. Fire Planning and Design Flowchart (section 2)

introduction

1.1.5 Planning Flowchart

To assist with designing and specifying a typical fire alarm system the planning flowchart shown in Figure 1 on pages 14 and 15, has been produced to provide a logical guide. This flowchart maps the main activities that should be considered when planning and designing a fire detection and alarm system. The side notes added to certain activity boxes are included for the purpose of directing the reader to relevant sections of this manual, where further detailed information can be found.

selecting the category of protection and coverage

2. Selecting the Category of Protection and Coverage

After initially consulting with all interested parties, the first decision to be made when designing a fire detection and alarm system is a simple choice of establishing the purpose of the system, that is whether it is for protecting the building, its contents and business continuity (Property Protection) or enhancing the safety of the occupants (Life Protection). British Standard BS 5839-1 categorises systems according to their purpose and the extent of protection to be afforded.

If it is determined that there should be no automatic detection, a simple system comprising sounders and break glass call points alone might suffice. This type of system is described as a Category M system.

- **Manual (Category M)**

Category M

A manual system, incorporating no automatic fire detectors.

Clause 5 of the code divides systems that incorporate automatic fire detection into two main Categories, according to whether the objective is life safety (Category L) or property protection (Category P).

The two Categories are then further subdivided, according to the extent of coverage by automatic fire detection.

- **Life Protection (Category L)**

This classification provides for the protection of life, that is the safety of the occupants. It caters for the detection of a fire, initiates an alarm of fire, and provides sufficient time for the occupants to escape from the building.

Category L5

The protected area and/or the location of detectors is designed to satisfy a specific fire safety objective. This may be defined in a fire engineering solution or from a fire risk assessment.

Category L4

Covers those parts of the escape routes comprising circulation areas and circulation spaces, such as corridors and airways.

Category L3

Covers escape routes and rooms opening onto escape routes (detectors may be situated adjacent to the door onto the escape route).

selecting the category of protection and coverage

Category L2

Covers the areas protected by Category 3 system plus other areas where it is considered that there is a high fire hazard and/or fire risk.

Category L1

Total coverage throughout the building.

- **Property Protection (Category P)**

This classification provides for the protection of property and its contents. It caters for the automatic detection of a fire, initiates an alarm of fire, and results in summoning of the fire brigade (which may be by a means of automatic transmission of fire signals to an Alarm Receiving Centre).

Category P2

Covers areas of high fire hazard or high risk to property or business continuity from fire.

Category P1

Total coverage throughout the building.

2.1 Category M – Manual

This is the simplest form of fire alarm system. It provides basic protection by break glass call points and sounders only. As this type of system has no automatic detection

devices, in the event of fire, it has to be manually initiated by activating a call point.

2.2 Category L5 - Life

Often the design of a Category L5 system is based on a fire risk assessment or arises from a fire engineering solution. The system may be provided to compensate for some departure from the normal recommendations of prescriptive fire protection codes, such as those dealing with means of escape. A Category L5 system may also be provided as part of the operating system for a fire protection system (e.g. a smoke control system).

The Category L5 system could be as simple as one that incorporates a single automatic fire detector in one room, but a Category L5 system could also comprise comprehensive fire detection throughout large areas of a building in which, for example, structural fire resistance is less than that normally specified in the circumstances.

The protection afforded by a Category L system might, or might not, incorporate that provided by a Category L2, L3 or L4 system.

selecting the category of protection and coverage

2.3 Category L4 - Life

In a Category L4 system, automatic fire detection is only provided within escape routes comprising circulation areas and circulation spaces, such as corridors and stairways. A Category L4 system will not necessarily provide significant time for all occupants to escape before smoke occurs in significant quantities within the escape routes. This level of protection will not, therefore, normally satisfy the requirements of legislation in buildings in which people sleep.

The objective of a Category L4 system is to enhance the safety of occupants by providing warning of smoke within escape routes. This may be satisfactory in a building in which legislation would not, in any case, require automatic fire detection. Although the need for a Category L4 system might be identified in a fire risk assessment, care should be taken to ensure that the absence of detectors within rooms opening onto escape routes (as would be found in a Category L3 system) is satisfactory to ensure the safety of occupants. There is, of course, nothing to prevent the installation of detectors in certain additional areas over and above the minimum necessary for compliance with the recommendations for a Category L4 system.

Detectors installed within the escape routes can be optical, CO or multisensor detectors.

2.4 Category L3 - Life

The purpose of a Category L3 system is to provide warning to occupants beyond the room in which fire starts, so that they can escape before escape routes, such as corridors and staircases, are smoke-logged. However, research has shown that fire gases passing through the cracks around doors can produce smoke sufficiently dense and cool for a corridor to become smoke-logged before adequate warning can be given by detectors in the corridor itself.

For this reason, in a Category L3 system, optical smoke detectors, or a mixture of optical smoke detectors, CO and or multisensor fire detectors, should be sited within the escape routes, while smoke, heat or carbon monoxide detectors should be installed in all rooms that open onto the escape routes. (Rooms opening onto corridors of less than 4m in length need not, however, be protected, providing fire resisting construction, including doors, separates these short corridors from any other section of the escape route.)

selecting the category of protection and coverage

An open plan area of accommodation, in which occupants will quickly become aware of a fire, need not be protected in a Category L3 (or L4) system unless the area forms part of the escape route from other areas (e.g. an enclosed office). However, in a Category L3 system, detection should be installed on the accommodation side of any door within the open plan area that opens into the escape routes (subject to the exception for the short lengths of corridor described above).

2.5 Category L2 - Life

The objective of the Category L2 system is identical to that of a Category L3 system, with the additional objective of giving early warning of a fire that occurs in specified areas of high fire hazard (i.e. where the outbreak of fire is likely) and/or areas of high fire risk (i.e. where the likelihood of fire in combination with the possible consequences of fire warrants protection).

It is for the designer to specify which rooms or areas of the building warrant protection, over and above the protection provided in a Category L3 system. It should not be left to the fire alarm contractor to guess the intention of the designer in this respect.

Upgrading Category L3 protection to Category L2 protection might not only involve provision of detectors in additional rooms or areas. It might involve a change in detector type and/or siting. For example, many building control and fire authorities accept heat detection within bedrooms of hotels, as they consider the purpose of these detectors is only to provide a warning of fire to occupants of other bedrooms, rather than the occupant of the room in which fire starts. Since this is effectively Category L3 protection, these detectors may also be wall-mounted on the walls of the bedrooms. However, in the case of a dormitory, this would be insufficient, and smoke detection would normally be required throughout the dormitory. Also, if any bedrooms are intended for use by disabled people, earlier warning of fire within the bedroom is necessary to provide additional time for escape. Again, in these bedrooms, the authorities would require smoke detectors (or, possibly, carbon monoxide fire detectors), and the detectors would be conventionally mounted on the ceiling. These smoke or carbon monoxide multisensor detectors, intended to protect the occupants of the room in which fire starts, are effectively part of a Category L2 system.

selecting the category of protection and coverage

2.6 Category L1 - Life

A Category L1 system provides the highest standard of protection of life. Fire detectors are installed in all rooms and areas of the building, except that the following rooms or areas need not be protected if they are of low fire risk:

- Toilets, shower rooms and bathrooms;
- Stairway, lobbies and toilet lobbies;
- Small cupboards (typically, less than 1m²);
- Small risers (typically, less than 1m²), if there is a fire resisting floor and ceiling within the riser.
- Some shallow voids (less than 800mm in depth).

In a Category L1 system, the detectors within escape routes should be optical smoke detectors, or multisensor fire detectors.

2.7 Category P2 - Property

A Category P2 system involves automatic fire detection in only specified areas of the building. The areas in which detection should be provided are those that are judged to have a high probability of fire and those in which the consequences of fire would be serious. In

considering the consequences of fire, account should be taken of both direct damage to property and the effect of fire on business continuity. As in the case of a Category L2 system, the specification should indicate the areas in which automatic fire detection is to be provided. It should not be left for the fire alarm installer to guess the designer's intent in this respect. The designer should, therefore, determine the requirements of the purchaser, who in turn should consult with the property insurers.

Points to consider in determining the need for protection in any area include:

- How probable is the likelihood of detection by people in the building?
- What sources of ignition are present?
- How combustible are the contents?
- How valuable are the contents?
- What is the likelihood of fire spreading from unprotected areas to areas with valuable contents or areas on which business continuity depends?
- What are the costs of extending the protection to all areas?

Usually, some form of balance has to be struck between cost and level of protection. BS 5839-1 gives no detailed advice in this respect, and so great care needs to be

selecting the category of protection and coverage

taken to ensure that the system will satisfy the objectives of the purchaser or user.

2.8 Category P1 - Property

A Category P1 is very similar to a Category L1 system, in that all areas of the building are protected, other than the exceptions described for Category L1. Thus, a Category P1 system provides the highest form of protection of property and protection against interruption to a business. It is, therefore, the most ideal system from the point of view of the property insurer.

how to configure detector zones and alarm zones within premises

3. Detector zones and alarm zones

3.1 The Meaning of a Detection Zone and Alarm Zone

BS 5839-1 defines a detection zone as 'a subdivision of the protected premises such that the occurrence of a fire within it will be indicated by a fire alarm system separately from an indication of fire in any other subdivision'. The code notes that a detection zone will usually consist of; an area protected by several manual call points and/or detectors, and is separately indicated to assist in location of the fire, evacuation of the building and fire-fighting. In earlier versions of BS 5839-1, a detection zone was described simply as a 'zone'.

The code defines an alarm zone as 'a geographical sub-division of the premises, in which the fire alarm warning can be given separately, and independently, of a fire alarm warning in any other alarm zone.' Thus, alarm zones do not occur in buildings in which there is single phase (simultaneous) evacuation of the entire building when the fire alarm system is operated. Alarm zones only occur in buildings in which there is a two (or more) stage alarm.

3.2 The Purpose of Detection Zones

The main reason for sub-dividing the premises into detection zones is to indicate the location of a fire as precisely as possible at the control and indicating equipment (CIE). This aids those responding to the fire alarm signal, particularly the fire service.

In conventional systems, each detection zone is connected to the CIE by a separate circuit. In addressable systems, however, one circuit may serve a large number of manual call points and detectors, grouped into several detection zones. In either case, each detection zone will have a separate number and visual indicator at the CIE. In the event of a fire condition, the visual indicator will illuminate, thus assisting people to identify the location of the fire by means of a zone plan, which should be mounted adjacent to the CIE.

Addressable systems are able to identify exactly which detector or call point is in the alarm condition, so pinpointing the exact location of the fire. Notwithstanding this major benefit of being able to locate precisely the origin of the fire, the building needs to be sub-divided into detection zones in accordance with clause 13 of the code. In general, the code states that the primary indication of the origin of the alarm

how to configure detector zones and alarm zones within premises

should be an indication of the detection zone of origin.

A display giving information only relating to the whereabouts of a particular detector in alarm (for example, CIRCUIT 2 DETECTOR 7 WORKS OFFICE) is useful, but in isolation may not provide an obvious indication of the spread of fire as further detectors go into alarm. The display of individual detectors in alarm should, therefore, be secondary to the light emitting visual indication of detection zone.

To satisfy this recommendation, a separate and continuous visible indication for each detection zone in which a detector or call point has operated will need to be given on the control and indicating equipment, or on a separate indicator panel connected to it.

A diagrammatic representation of the building showing the detection zones should be provided adjacent to the control and indicator panel, as defined in Clauses 3 and 23 of BS5839-1.

3.3 Detection Zone Configuration Guidelines

There are several recommendations regarding the size and configuration of a detec-

tion zone that are common to both conventional and addressable fire systems:

1. The maximum floor area of a detection zone should not exceed 2,000m². (However, in large, open plan areas, such as warehouses, if the detection zone only contains manual call points, this may be increased to 10,000m².)
2. The search distance, that is the distance that has to be travelled by a searcher within a detection zone in order to determine visually the position of the fire (not reach the fire), should not exceed 60m. (Search distance need not be applied to addressable systems if a suitable display of location would enable fire-fighters to go straight to the fire.)
3. If the total floor area of a building is less than 300m², then the building need only be one detection zone, regardless of the number of floors.
4. If the total floor area of a building is greater than 300m², then each floor should be a separate detection zone (or set of detection zones, if the floor area is large enough).

how to configure detector zones and alarm zones within premises

5. A single, vertical detection zone should be provided for fire detectors within an enclosed stairwell, lift shaft or similar enclosed flue-like structure. However, any manual call point on the landing of a stairwell should be incorporated within the detection zone that serves the adjacent accommodation on the same level as the landing.

3.4 Detection Zone Safeguards

It is possible for addressable detectors to share one circuit all round the building, thereby having several detection zones served by the same two-wire circuit. For conventional detectors, each individual detection zone is served by its own dedicated two-wire circuit.

To ensure that an addressable system does not have a lower level of integrity than a conventional system, the code makes various recommendations that limit the effects of faults.

1. A single fault occurring on an automatic fire detector circuit should not disable protection within an area of more than 2,000m², nor on more than one floor of the building plus a maximum of five devices on the floor immediately above and five devices on the floor immediately below that floor.

In conventional systems this will normally be achieved as a matter of course, since an open or short circuit condition will only affect the individual detection zone circuit concerned (See Figure 2). The detection zone will be no more than 2,000m² in area and, other than in very small buildings, will serve no more than one floor.

In addressable systems where a number of zones share the same ring circuit or loop (See Figure 3), an open circuit is not too much of a problem (just so long as the fault is reported) since the loop can be driven in both directions. The case of a short circuit however is far more serious since this condition could prejudice every device (up to 250) on the circuit. Short circuit protection is therefore required in all loop circuits. This is achieved by placing line isolator devices at appropriate locations in the loop circuit, so that the area protected by detectors between any two line isolators is no greater than 2,000m² and these detectors are on the same floor level.

how to configure detector zones and alarm zones within premises

For example, with reference to the circuit shown in Figure 3, if a short circuit were to occur in detection zone 2, the two line isolators X and Y would operate and create two breaks in the circuit at points X and Y. The loop would

then drive in both directions, that is, detection zone 1 in one direction and zones 5, 4 and 3 in the other direction. The line isolators would again automatically become passive after the short circuit has been repaired.

Each circuit serves no more than 2,000m² and no more than a single floor

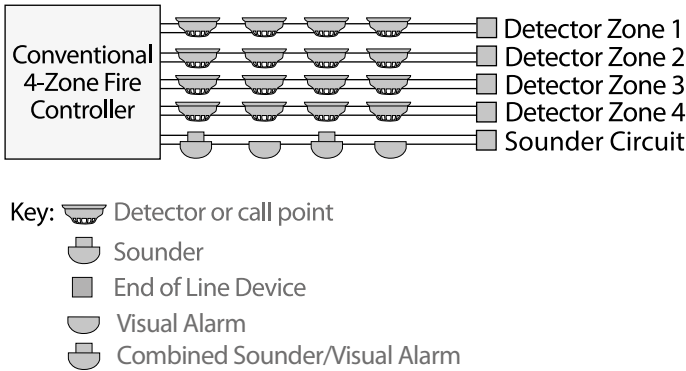
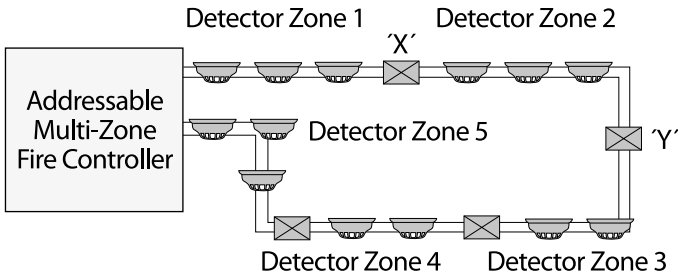

fig 2. Conventional System Circuit

section one | guide to design, installation, commissioning and maintenance of fire systems in non domestic premises

how to configure detector zones and alarm zones within premises

Circuit 1 to 4; 250 points per circuit



- Key: Detector or call point
 Zone/ Line Isolator Module
 ('Y' may be omitted if Detector Zones 2 and 3 are small and both on the same floor)

fig 3. Addressable Loop System Circuit

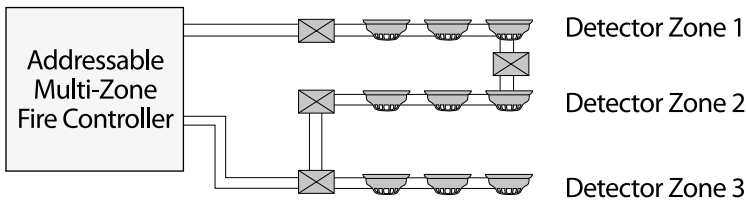

- Key: Detector or call point
 Zone/ Line Isolator Module

fig 4. Addressable Loop System Circuit with Spurs.
 Where detectors and ancillaries have integral line isolators, additional isolators are not required.

how to configure detector zones and alarm zones within premises

In addressable systems where detectors are connected on a 'spur' off a loop, (see Figure 4), to comply with the recommendation of the code then the spur should not serve more than one floor or an area of greater than 2,000m².

When you have established the detection zone arrangement for the building, the next step in the design process is to decide which type of fire alarm system should be used, see section 4 (Which Type of Fire Detection and Alarm System?).

2. Two faults should not remove protection from an area greater than 10,000m². This recommendation imposes a maximum area of coverage for a single loop in an addressable loop system (see Figure 3). No loop in the system therefore should ever serve an area of coverage greater than 10,000m². If the area to be protected exceeds this maximum limit, then an additional loop(s) should be used.
3. Open circuit and short circuit faults should be reported at the control panel within 100 seconds of occurrence

This limitation will be satisfied if control equipment conforms to BS EN 54-2.

which type of fire detection system

4. Which Type of Fire Detection and Alarm System?

Three types of fire alarm detection systems are available and covered by the code. These types are broadly defined as:

- Conventional Systems
- Addressable Systems
- Digital Addressable Systems

Irrespective of which type of system is selected, the guidelines set out in Sections 2 and 3 still apply.

In premises where the evacuation of personnel is more difficult, such as in residential care; The importance of providing accurate and unambiguous information, such as can be provided only by addressable systems, is strongly recommended. Clause 4 of BS5839 refers

In the following subsections, we compare and contrast the differences between the three types of systems.

4.1 Conventional Systems

A conventional or two-state detector is a detector which gives one of two states relating to either normal or fire alarm conditions.

Conventional systems provide a number of two wire circuits onto which conventional detectors and call points are connected. Similarly, separate two wire circuits are also provided for the purpose of connecting sounders (or alarm bells) to the system (see Figure 2 in Section 3).

The primary function of the control and indicating equipment (CIE) is to indicate the location of a fire as precisely as possible. To achieve this objective, detectors are grouped into detection zones, with each detector zone being connected to the CIE by a separate circuit, which also has a separate indicator on the control panel.

Each detector includes an integral LED (light emitting diode) indicator which illuminates when the device is in the fire alarm condition. If an indicator on the CIE indicates a fire in a detection zone, the detection zone must be physically searched until the detector with the illuminated LED is found. Detectors installed out of view normally have a remote LED indicator.

4.1.1 Detection Zones

If zoning were to be extended to the limit, each circuit would have only one detector connected, and the exact location of the fire could be established at the CIE

which type of fire detection system

without the need to physically search the zone. To do this with conventional detectors and a conventional control panel would be prohibitively expensive because of the number of detection zones required on the CIE and the large amount of installation work involved.

In conventional systems, all the detectors on a detection zone circuit continuously communicate with the CIE. When one detector goes into the fire alarm state, the voltage on the circuit drops and all other detectors on that detection zone become disabled. During this period no further signals from other detectors in the detection zone can be received at the CIE.

4.1.2 Detectors and Call Points

Point smoke detectors used in conventional systems must conform to the requirements of BS EN 54-7. Similarly, point heat detectors must conform to the requirements of BS EN 54-5. Flame detectors must conform to the requirements of BS EN 54-10.

Manual break glass call points must conform to the requirements of BS EN 54-11. The code recommends the use of 'Type A' manual call points, which require only one action to operate them (i.e. breaking the glass automatically sets off the fire alarm

system). However, if manual call points are likely to be subject to casual malicious operation (e.g. in some schools, student residences, public entertainment premises, etc), a variation might be accepted by the building control and fire authorities, whereby on next time a hinged plastic cover is fitted to each call point. The cover then has to be lifted before the glass can be broken.

The code states that the removal of a detector on a circuit should not prevent the operation of any break glass call point. In a conventional system, unless the system is designed in such a way that removal of every detector from a detection zone circuit does not disable other devices that remain connected, it will be necessary to either connect manual call points on a separate circuit from fire detectors or to install all call points as the first devices on the circuit, with any automatic fire detectors 'downstream' of these.

4.2 Addressable Systems

An addressable system is one using addressable detectors and/or call points, signals from which are individually identified at the control panel.

which type of fire detection system

In a simple addressable system, the CIE can provide a number of two wire circuits onto which addressable detectors and call points may be connected. The two wire circuit should be connected to form a loop in order to provide circuit integrity. In addition to this, line isolators should be distributed around the loop to ensure compliance with the code.

4.2.1 Operation of Addressable Systems

In an addressable system, multiplex communication techniques allow each detector to independently signal its status back to the control panel. Since each detector has its own identity (or address) the control panel, in addition to providing the normal detection zone, may also be configured to give a customer defined character message to each detector. This is especially useful to any observer who is not familiar with the layout of the site. The customised messages are usually displayed on a text and/or graphical display alongside the visual detection zone indicators.

In operation, the control panel sends out the first address and then waits a pre-set time for a reply. Each detector compares the address sent out by the control panel with its own pre-set address and

the one that matches the address sends back its status. If a particular detector address is not found within the pre-set time because the device has been either disconnected or removed, the control panel indicates a fault. Similarly, if the detector address is found but the device fails to operate correctly (that is, reply) within the pre-set time then the control panel also indicates a fault.

The control panel then sends out the next address, and so on until all devices have been addressed, and then it repeats the whole cycle again.

Clearly it is possible for many detectors on the same circuit to be in alarm at the same time and for the CIE to recognise this. This means that much more information about the spread of fire within a zone can be obtained. Because of the communication techniques involved, the detectors do not have to be arranged on the circuit in address order, hence circuit wiring can take the most economical route. This method obviates the necessity of accurate installation drawings.

4.2.2 Detectors and Call Points

Addressable detectors and manual call points must conform to the same standards (i.e. the same BS EN) as conventional devices.

which type of fire detection system

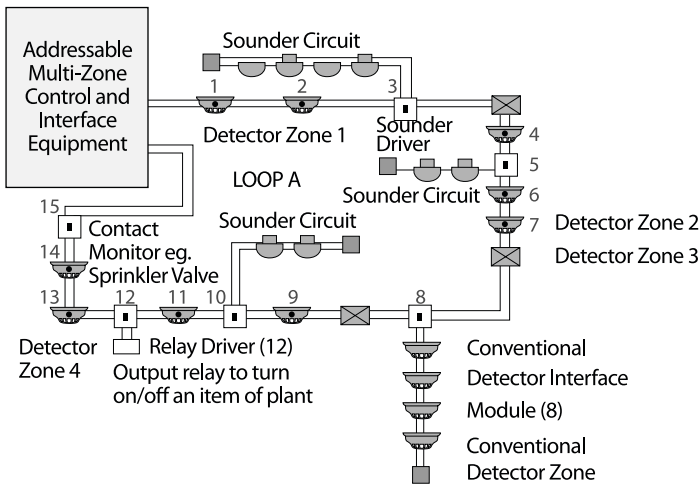

Note: Devices at addresses 3, 5, 8, 10 and 12 require a 24V d.c. supply to power the sounders (or bells) and detectors. This can be achieved by using addressable (and therefore monitored) remote power supply units

Key:

- Conventional Detector or Call Point
- Addressable Detector or Call Point
- Addressable Input or Output Command Module
- Sounder
- Line Isolator Module
- End of Line Device
- Visual Alarm
- Combined Sounder/Visual Alarm

fig 5. Addressable Loop System Circuit with Conventional Spur and Addressable Output Modules. Where detectors and ancillaries have integral line isolators, additional isolators are not required

which type of fire detection system

The removal of a detector on a circuit will not prevent the operation of any break glass call point. This is achieved in an addressable system because removal of a detector does not cause any break in the circuit. The removal of the detector is sensed by the absence of a 'reply' when the detector is polled by the CIE.

A contact monitor module is another device which can be used on an addressable system. This device is used for monitoring very simple items that provide a closing or opening volt free contact, for example a sprinkler flow valve.

4.2.3 Output Devices

Besides handling input devices, that is, detectors and call points, addressable systems can also handle output devices on the addressable loop. This is possible because part of the address message from the control panel can be a command instruction to an output device, signalling it to turn its output ON or OFF. A typical application of this would be a sounder module used to drive a number of sounders (or bells), and / or visual alarm devices, or a plant interface module used to shut down a piece of electrical plant. All command instructions sent to output devices are ignored by input devices on the circuit (see Figure 5).

It is also acceptable to connect interface modules to conventional circuits. These modules allow conventional detectors on spur detector circuits to be connected to an addressable zone circuit and monitor the status of typically 20 conventional detectors. The conventional detectors on the spur communicate with the interface module and should any detector go into alarm, the interface module signals to the control panel that an alarm condition has occurred. These modules are also often used to upgrade old conventional systems, by utilising the existing wiring, although new wiring should always be used where possible.

In order to provide short circuit protection and comply with the requirements of the code, isolators must be fitted at appropriate positions on an addressable loop (see Section 3.4).

which type of fire detection system

4.3 Digital Addressable Systems

In practice all addressable systems are of the analogue type. A digital system is one which uses analogue addressable detectors, each of which give an output signal representing the value of the sensed phenomenon. The output signal may be a truly digital signal or a digitally encoded equivalent of the sensed value. The decision as to whether the signal represents a fire or not is made at the CIE.

Apart from the way in which analogue addressable detectors operate, and the CIE communication principles employed, all system design elements of addressable systems (see Section 4.2) also apply to analogue addressable systems.

Conventional and two state addressable detectors can signal only two output states, normal and fire alarm.

Consequently, with these detectors it is impossible to ever establish how close the device is to an alarm condition, or whether the localised environmental conditions (which probably contain dust and dirt) are causing deteriorating changes in the detector's sensitivity, thereby adversely affecting its performance. However, an addressable system can offer a number

of system performance improvements over both conventional and simple (non-analogue) addressable type systems, details of which are highlighted in the following subsections.

4.3.1 Operation of Analogue Addressable Detectors

The output of an addressable detector is variable and is a proportional representation of the sensed effect of fire, that is smoke, heat, carbon monoxide or flame (see Figure 6). Transmission of this output from the detector is usually in the form of an analogue current. In digital systems however this output is expressed and transmitted in data bits, using zeros and ones. The communication of the data is made more secure using FSK, thereby ensuring a high level of discrimination between these different bit values. When the detector is interrogated or addressed by the control panel, the analogue detector responds with an output value rather than a status value as in the case of conventional detectors. In an analogue addressable system therefore, the analogue addressable detectors are simply acting as transducers which relay information (back to the control panel) concerning temperature, smoke density, etc. Microproces-

section one | guide to design, installation, commissioning and maintenance of fire systems in non domestic premises

which type of fire detection system

sor based circuitry in the control panel interprets the data received and decides whether or not to indicate an alarm, pre-alarm, normal or fault condition.

In order that the system raises an alarm in the event of a fire, the analogue value output from the detector must be in the alarm condition (that is, above the alarm threshold) for a period equal to the time taken to complete three successive address sequences, typically fifteen seconds. This technique of scanning the sensor three

times before raising an alarm is a useful way of helping to reduce false alarms from short term electrical or physical transients, without causing an excessive delay in actual alarm transmission.

As the output from each detector is an analogue value, the alarm threshold level can be controlled (or set) by software within the CIE. This software is usually stored in non-volatile memory (EEPROM) when the system is being configured during installation.

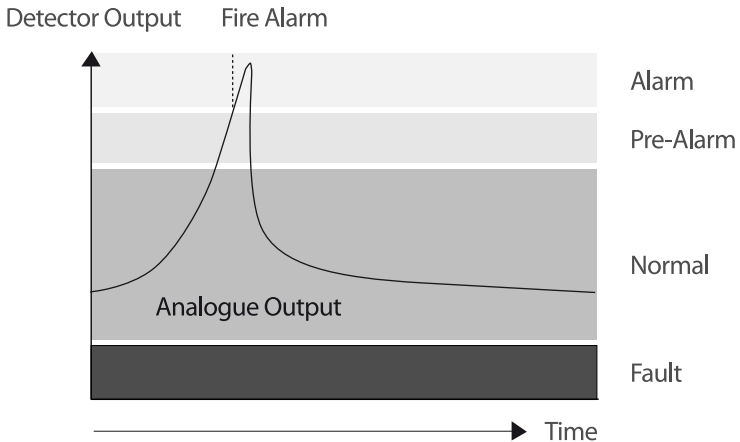

fig 6. Graph showing the Output of an Analogue Detector Responding to a Fire

which type of fire detection system

4.3.1.1 Detector Pre-Alarm Warning

Quite often in the early stages of a smouldering fire there is a slow build up of smoke before open burning takes place. With an analogue addressable smoke detector, the analogue value rises as the smoke builds up in the detector's sampling chamber. At a certain threshold level, that is the pre-alarm level (see Figure 7), the control panel can give a visual indication and audible

warning of this pre-alarm condition before a full-scale evacuation of the building is required and before the fire service are called. This situation allows the possible cause of the pre-alarm to be investigated prior to a full alarm condition. It also allows for primary fire fighting procedures (using portable extinguishers) to be put into effect. The pre-alarm signal also provides an opportunity to filter out false alarms.

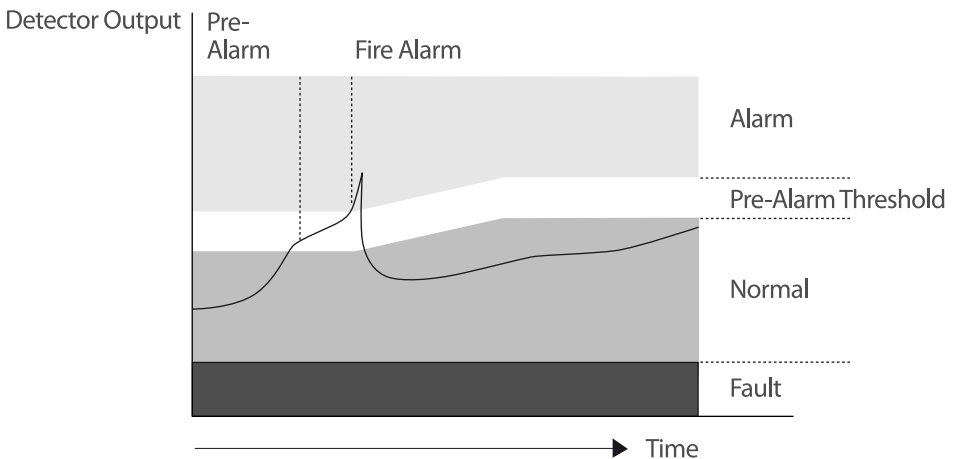

fig 7. Analogue Addressable Detector Typical Pre-Alarm Threshold Level

section one | guide to design, installation, commissioning and maintenance of fire systems in non domestic premises

which type of fire detection system

4.3.1.2 Detector Alarm Threshold Compensation

As detectors age and become contaminated with dust and dirt their performance begins to deteriorate such that their potential to go into an alarm condition is that much higher, thus resulting in false alarms. The nuisance factor caused by false alarms is a serious problem for users and fire services alike.

Since the output analogue value of each detector is continually checked by the control panel, the slow build up of conta-

minants in the detector is reflected by a slow increase in the analogue value. As this occurs, the control panel can alter the alarm (and pre-alarm) threshold in order to compensate for this phenomenon (see Figure 8).

This feature maintains the system at an optimum performance level and extends the life of each analogue addressable detector.

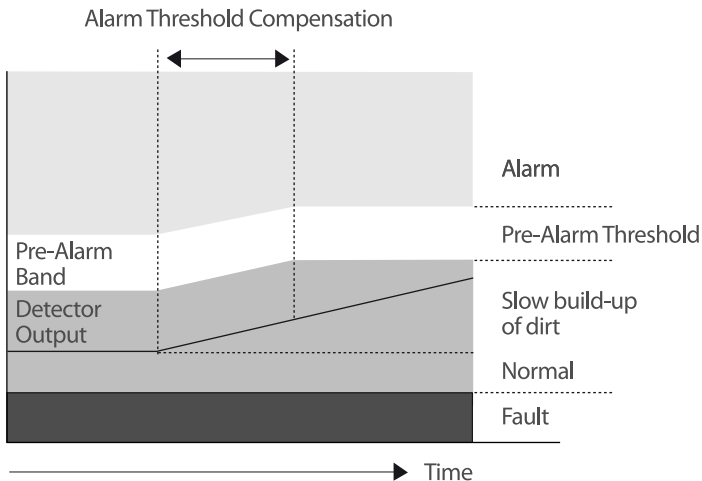

fig 8. Analogue Addressable Detector Alarm Threshold Compensation

which type of fire detection system

The threshold compensation is not adjusted every time there is a minor fluctuation in the detectors sampling chamber. However, the control panel does take an average of the analogue value over the preceding hour and alters the threshold level accordingly.

4.3.1.3 Detector Condition Monitoring

In accordance with the threshold compensation (see subsection 4.3.1.2), there comes a time in the life of a detector when threshold compensation can no longer

be applied due to the dynamic range of the analogue signal. When this occurs, the control panel senses that the detector has reached the end of its operational life, and indicates a detector condition monitoring fault.

When a detector condition monitor fault is indicated, the detector must be replaced by a new one and the threshold compensation for the detector's address is automatically reset. Typically this point will only be reached after several years of operation.

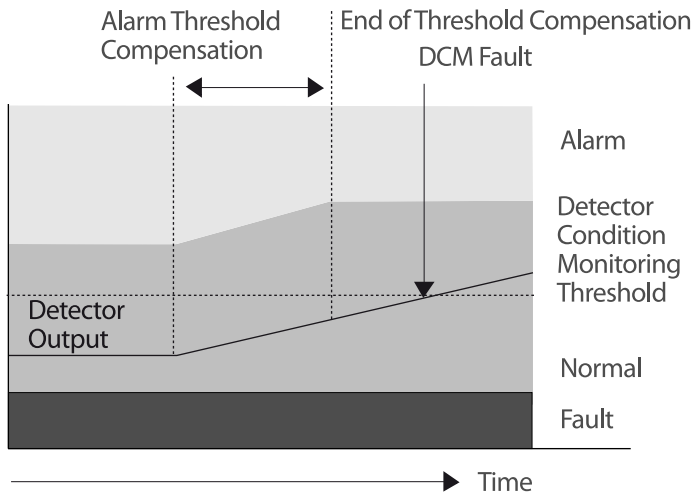

fig 9. Analogue Addressable Detector Condition Monitoring Threshold

which type of fire detection system

4.3.1.4 Detector Sensitivity Setting

Unlike conventional or addressable fire detectors where the sensitivity is fixed, each analogue addressable detector can be made to emulate a normal, low or high sensitivity smoke detector by simply selecting the appropriate threshold settings for each address in the software configuration at the CIE. Likewise, the sensitivity of heat detection can be selected in the software configuration at the CIE.

The option of being able to change the sensitivity settings of detectors can be useful in many situations. For example, at certain times of the day when the building is occu-

ped you might want to reduce the sensitivity level of detectors in selected zones. This feature allows the settings to be manually switched to low sensitivity for those zones and then switched back to normal sensitivity when the premises are again unoccupied (see Figure 10). There may be many reasons why you might want to do this, one being that you want to reduce the possibility of a false alarm occurring during the working day, but you want full protection at all other times.

The choice of alarm level sensitivities, plus any time delay which may be deliberately introduced, determine the overall system response to fire conditions. The alarm level

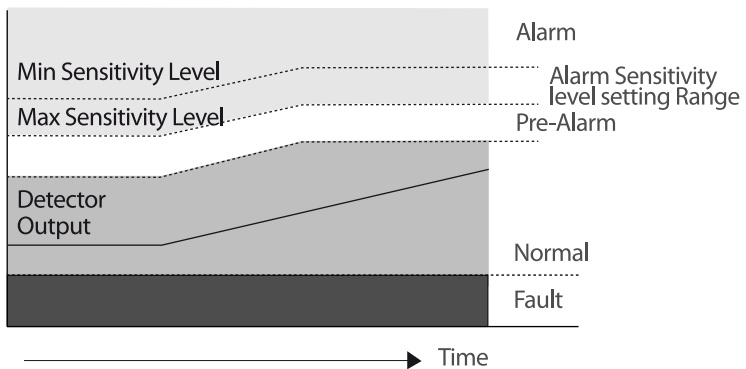

fig 10. Analogue Addressable Detector Alarm Sensitivity Level Setting Range

which type of fire detection system

and time delay can in theory be allocated any value, but in practice the sensitivity range must be within the limits necessary to ensure compliance with the relevant part of BS EN 54.

When you have determined the type of fire detection and alarm system to use in the building, that is, conventional or addressable, the next step in the design process is to decide which type of detectors should be used in the different areas (zones) to be protected, see section 5 (Detector Suitability).

detector suitability

5. Detector Suitability

Once you have decided upon the type of fire detection and alarm system to use in the building, that is conventional, addressable or digital addressable, you now need to choose which type of detectors are to be used to protect the different areas within the premises.

There are several types of detector spread across the range, each of which responds to a different product of combustion (smoke, heat, etc.). Manual call points are used to provide a means for people in the building to raise the alarm.

The different detector types available are as follows:

- Multisensor
- High Performance Optical Smoke Detector
- Optical Smoke Detector
- Infra-Red Flame Detector
- Optical Beam Detector
- Aspirating Detector
- Linear Heat Detector
- Duct Probe Unit

5.1 General Fire System Engineering Principles

As each type of detector responds to a particular fire product, the relative speed of response of the detectors is therefore dependent upon the type of fire being detected. As smoke is normally present at an early stage in most fires, smoke detectors (Ion Chamber, Optical, High Performance Optical or Multi-sensor) are considered the most useful type available for giving early warning.

Most fires, in their later stages, emit detectable levels of heat. Therefore in areas where rapid fire spread is unlikely and environmental conditions preclude the use of smoke detectors, heat detectors (Rate of Rise or Fixed Temperature) are a general purpose alternative, but these should not be used in the escape routes of a Category L system.

Fires tend to produce carbon monoxide, particularly in situations in which there is insufficient ventilation to enable fire to burn rapidly. Accordingly, carbon monoxide fire detectors provide useful warning of such fires. The carbon monoxide fire detector is well suited to provide early warning of slow smouldering fires. Slowly developing and

detector suitability

smouldering fires produce large quantities of carbon monoxide before detectable smoke aerosols and particulates reach smoke detectors in sufficient quantities to detect the fire. These detectors can often be used in applications in which heat detectors are insufficiently sensitive, but smoke detectors may cause false alarms from sources such as steam from a shower or smoke from burnt toast.

In situations where a burning liquid, for example alcohol, paint thinner, etc. is likely to be the prime source of a fire, and flame is most likely to be the first indication a fire has started, then an Infra-Red Flame detector should be incorporated into the system.

Although heat, smoke and carbon monoxide detectors are suitable for use inside most buildings, flame detectors may be used to supplement these where necessary. Flame detectors need an unobstructed line of sight, their greatest use being for such special applications as the supervision of an outdoor storage area or an area where petrochemical processes are taking place, for example offshore oil platforms. Infra-red flame detection can also be used to protect very high spaces, such as cathe-

drals, where the height is such that point smoke detectors cannot be used.

Also available are specialised detectors which have been specifically designed for use in applications where point and line-type detectors cannot be used. Two types are available, namely the Aspirating detector and Duct Probe Unit.

The Aspirating type detector comprises a small pump which draws a sample of air through holes in a pipe that is connected into a detector element. The detector element of the Aspirating detector is usually very much more sensitive than conventional point detectors to allow for the effects of dilution of smoke. This type of detector is normally used for protecting such areas as computer suites, clean rooms, or the interior of historic buildings where point or line-type detectors would look out of place. For further information also see subsection 5.2.6.

The Duct Probe Unit has been designed for use in situations where smoke, heat and flame type detectors cannot be used. It is primarily used for detecting the presence of smoke or combustion products in ventilation ducting systems. The detector has a small probe which protrudes into the duct and draws air from

detector suitability

the duct into the detector. For further information also see subsection 5.2.7.

5.2 Detector Selection for a Particular Area

The ability of any particular detector to respond to the various types of fire within different types of environment depends upon a number of factors, such as the operating principle, the sensitivity of the detector and the type of fire that occurs (e.g. smouldering or flaming).

The decision as to whether the detector is conventional or analogue addressable is a separate issue because the principle of the detection method remains the same. The dirtier the environment is, the more preferable the analogue addressable system becomes. Also the more cellular the space within a building is, the more preferable the addressability of analogue systems becomes.

In planning and designing the fire system, you may find the detector suitability selection chart shown in Table 1 below useful in determining the detector type(s) best suited for the specific environment into which the system is to be installed.

5.2.1 Smoke Detectors

To understand exactly how smoke detectors operate, you first need to know a little about the composition of smoke. Most fires produce smoke from their earliest stages, but the density and colour of the smoke depends very much upon the material that is burning and the conditions of combustion.

The differences between various types of smoke are caused by the variation in the size of the particles that make up the smoke. As a general rule, the hotter the fire the greater the number of very small (invisible) smoke particles. Conversely, a fire with low temperature decomposition produces proportionally more larger (visible) smoke particles.

Ion Chamber Smoke Detectors: These detectors are slowly being phased out due to a number of factors. Firstly they contain a small radioactive cell (americium) which is the alpha particle source used to create the detection chamber. This is not clean technology and creates problems and costs when disposing of these.

Secondly technology has, with the introduction of multi sensor detectors, provided better fire detection which covers those fire types previously suited

detector suitability

to Ionisation smoke detectors, without any of the disadvantages.

Optical Smoke Detectors: These detectors respond quickly to large smoke particles but are less sensitive to small particles that do not constitute visible smoke. They detect the visible particles produced in fire by using the light scattering properties of the particles.

The detectors comprise an optical system which consists of an emitter and a sensor, each of which have a lens in front, and are so arranged that their optical axes cross in the sampling chamber. The emitter produces a beam of light which is prevented from reaching the sensor by a baffle.

When smoke is present in the sampling chamber, a proportion of the light is scattered and some reaches the sensor. The light that reaches the sensor is proportional to the smoke density.

High Performance Optical (HPO) Smoke Detectors: HPO detectors respond to smoke in the same way as standard optical detectors, but, when there is a rapid rate of rise in temperature, their sensitivity is increased so that they also respond to very small smoke particles, more like the Ion Chamber type detectors.

5.2.2 Heat Detectors

Heat detectors are normally used where the speed of operation of smoke detectors is not required or where, for environmental or other such reasons, smoke detectors cannot be used in the system. In such circumstances, heat detectors can provide an acceptable, though less sensitive alternative. Three types are available. These are the Rate of Rise detector, the Fixed Temperature detector and the Line Type detector. Careful consideration should be given to the type of heat detectors that are to be used in certain areas. Rate of Rise type detectors, for example, should not be used in areas where large sudden changes in temperature are normal (such as in a kitchen), otherwise false alarms will occur.

The upper limit response times for the different types of heat detectors, as prescribed in BS EN 54-5, are shown in Table 4. It should be noted that Class A1 heat detectors are more sensitive (and hence will respond quicker) than Class A2 detectors. For this reason, Class A1 detectors can be used at a greater ceiling height than Class A2 detectors (see Section 6). Class B - G detectors are only used where the ambient temperature is higher than normal.

Rate of Rise Heat Detectors Of the three heat detector types available, these are the

detector suitability

preferred type. These detectors react to abnormally high rates of change of temperature and provide the fastest response over a wide range of ambient temperatures. A fixed temperature limit is also incorporated in these detectors. These detectors are ideally suitable for use in areas where a large change in ambient temperature is likely to occur by the stage at which it is necessary to detect a fire.

Fixed Temperature (Static) Heat Detectors
These detectors are similar to the Rate of Rise type detectors except that they react at a pre-determined temperature rather than a rate of rise temperature. These detectors are ideally suitable for use in areas where sudden large changes in temperatures are considered normal, for example in kitchens and boiler rooms.

Line-Type Heat Detectors. These detectors are not commonly used however they offer advantages in some applications. Point type detectors such as the rate of rise and Fixed Temperature types are designed to sense the conditions near a fixed point. Where more than a single detector is required, detectors are spaced in accordance with the standard so as to effectively cover the area. Line-Type detectors, however, come in the form of a length of wire or tube, and are designed to sense the condi-

tions anywhere along its entire length. This makes them ideally suited for such applications as cable tunnels, cable trays and risers, high rack storage areas, transformer bays, thatched roofs, building services, subways and ducts, aircraft hangers, etc. Two versions are available, non-integrating and integrating.

The non-integrating Line-Type heat detector usually consists of an electric cable, with insulation of fixed melting point, which is suspended over the area to be protected. If one small section of the wire is heated up (due to fire) and the temperature of the section is greater than or equal to the melting point of the wire, the melting of the insulation results in a short circuit and causes the system to go into alarm.

The integrating Line-Type heat detector is similar to the non-integrating version except here the insulation does not melt. Its electrical resistance is temperature dependent. In effect, the average temperature is taken over the whole length of the wire rather than just sections of it. Consequently, a large amount of heat in a small area would need to be generated in order to create an alarm.

detector suitability

To allow for easy location of alarm or fault conditions, it is recommended that the maximum length of the sensing wire used with Line-Type detectors be limited to 200 metres. Lengths of up to 500 metres are available for special requirements. High resistance sensor wire is also available for use in areas with high ambient temperatures, that is, temperatures greater than 50 °C.

Fibre Optic heat sensor

Fibre optic sensor is used to detect temperature differentials, by using pulsed lasers. The temperature change is measured by analysing back scattered light resulting from the effects of the heat source. The location of the heat source is pinpointed by using a pulse echo technique (RADAR). The system is many times more sensitive than either of the two previous linear sensors. Sensor cable can be run over distances of up to 8km and heat sources pinpointed to within a 1 metre length of fibre. Alarm criteria can be set using 3 different measurements, by exceeding the defined maximum temperature, by exceeding the defined maximum temperature rise, by exceeding the defined maximum difference from the average zone temperature. Multiple zones can be created within a single fibre

with different alarm criteria set for each zone. Suitable applications are as defined for the two previous linear sensors but essentially fibre is preferred where long runs are required together with accurate alarm data, such as critical processes, cable tunnels, road and rail tunnels etc. The sensor operates within a range of -10°C to +60°C.

section one | guide to design, installation, commissioning and maintenance of fire systems in non domestic premises

detector suitability

5.2.3 Heat-enhanced Carbon Monoxide Fire Detectors

Heat-enhanced carbon monoxide fire detectors use an electrochemical cell to

detect the build up of carbon monoxide generated by fires. The cell operates by oxidizing carbon monoxide on a platinum sensing electrode. Within the electrochemical cell the ions produced by this reaction result in a

Rate of Rise of Air Temperature	Class A1 (mins, seconds)	Class A2 or Classes B - G (mins, seconds)
30°C/min	1, 40	2, 25
20°C/min	2, 20	3, 13
10°C/min	4, 20	5, 30
5°C/min	8, 20	10, 0
3°C/min	13, 40	16, 0
1°C/min	40, 20	46, 0
Maximum Static response temperature	65°C	70 - 160°C depending on class
Max. Ambient Temp.	50°C	50° - 140°, depending on class

table4. Upper limit response times for heat detectors

detector suitability

current flow between electrodes. The electrical output of the cell is directly proportional to the carbon monoxide concentration. The performance of the detector is relatively unaffected by changes in temperature, pressure or airflow. The electrochemical cell typically has a life of around five years, after which it should be replaced.

Tyco heat-enhanced carbon monoxide fire detector can be set in a digital system to provide high, normal and low sensitivity.

When set to normal sensitivity, an alarm signal will be given at a carbon monoxide concentration of 40 parts per million. For comparison purposes, background carbon monoxide levels generally remain well below 10 parts per million, with excursions of up to around 15 parts per million under unusual atmospheric conditions. Even in rooms with heavy smokers, or close to a source of air pollution, ambient levels of carbon monoxide generally remain below the 40 parts per million level at which a carbon monoxide fire detector operating at normal sensitivity will give an alarm signal.

Although, in the areas that BS 5839-1 accepts the use of carbon monoxide fire detectors, the detectors should be sited and spaced following the same recommenda-

tions as applicable to smoke detectors, in practice, carbon monoxide detectors are likely to be more tolerant of position relative to the seat of the fire, than smoke detectors.

As carbon monoxide is a gas, it diffuses to create a uniform concentration within the space in which it is generated. Thus, it is likely that carbon monoxide fire detectors will be less affected by obstructions and heat barriers than smoke detectors. In addition, carbon monoxide fire detectors in corridors may detect fire in an adjacent room before a smoke detector in the corridor, as carbon monoxide will diffuse evenly throughout the corridor, whereas smoke will tend to cool to an extent that there is insufficient buoyancy to remain at the level at which smoke detectors are installed.

Heat-enhanced carbon monoxide fire detectors are particularly suitable for detecting smouldering fires and fires within confined spaces, such as bedrooms within a sleeping risk. In the latter application, carbon monoxide fire detectors will provide a higher standard of protection for sleeping occupants than heat detectors, but are less likely to produce false alarms than smoke detectors. The addition of a heat sensor to enhance the sensitivity of the carbon monoxide sen-

detector suitability

sor enables heat-enhanced carbon monoxide detectors to respond to a wider spectrum of fires that generate heat as well as CO.

Carbon monoxide fire detectors are not suitable for fires that generate little or no carbon monoxide. Such fires include the early stages of electrical cable decomposition, where the HPO detector or aspirating fire detector is more suitable. Carbon monoxide fire detectors are also unsuitable for protection of areas where fast burning chemical fires represent the main hazard. In this case, ion chamber or flame detectors are more suitable.

Although heat-enhanced carbon monoxide fire detectors respond to BS EN 54-7 Test Fires, they do not detect smoke. It should be noted that these Test Fires do not represent all real fires, nor are they intended to do so. In particular, they tend not to produce carbon monoxide in the early stages of the fire. Real fires, particularly those of a smouldering nature, may actually produce carbon monoxide before they produce sufficient smoke of high enough temperature to operate smoke detectors. The detector can detect smouldering fires at levels below that of a single channel smoke detector but with the benefit of sampling combustion gas, heat and smoke build up as part of its analysis. All of which provides for a more accurate assessment of the question, Fire or false alarm.

This detector can, in addition to the two modes described above, also be configured as, a Heat detector, a High performance optical smoke detector or a Carbon Monoxide toxic gas detector. In all there are seven selectable operating modes.

5.2.4 Flame Detectors

Infra-Red flame detectors, unlike smoke and heat detectors, do not rely on convection current to transport the fire products to the detector, nor do they rely on a ceiling to trap the products. They detect electromagnetic radiation, which travels from a flame at the speed of light. They respond only to the short wavelengths of very high temperatures such as that present in flames. The radiation from flames is characterised by a flicker at a frequency in the range of 5 to 30 cycles per second.

To safeguard against false alarms, these detectors have inbuilt features which inhibit them from responding to phenomena such as the long wavelength radiation given off by hot or over-heated bodies, or the steady radiation given off from hot objects where there is no fire (even if the radiation is of the same wavelength as that of a flame). They also contain circuitry to prevent false alarms from momentary effects. The flickering shortwave infra-red radiation must be maintained for a period

detector suitability

of time (depending on its magnitude) before an alarm is given.

Flame detection- options

Infra Red Flame detectors all detect the same thing, i.e radiation which is released by hot CO² molecules within the flame. What differs however is the sensor technology used and the number of sensors employed within a detector, all of which determine its limitations and range of applications.

Single channel detectors, such as point type detectors employ just a single IR sensor and although solar blind, do not filter background radiation and therefore are restricted for use in internal areas . The single channel device relies mainly on the flame flicker analysis to detect fire and is less immune to other sources if similar flicker content is present.

Dual channel sensors are designed with an additional sensor which is set to a different frequency in order to detect and eliminate background radiation, (black body).

A triple channel sensor, is designed to monitor the Infra red spectrum at three chosen frequencies, the CO² band and one either side, in order to detect and eliminate background radiation. The triple channel

IR detector is therefore more reliable and is frequently used outdoors and in more extreme conditions such as found offshore.

Recent developments in triple IR technology has extended the detectors range from 50 to 65 metres in addition to providing outputs allowing connection into third party systems using 4-20mA , modbus and other protocols. It is also now possible to include a CCTV camera within the detector housing which connects over twisted pair to a proprietary CCTV system and which transmits live images of the detectors field of view.

Flame Detectors- Array based flame detectors use a different technology to those previously described.

The detector uses an array of 256 sensitive infra-red sensors to view the protected area. The IR array is combined with 2 other optical sensors to provide 3 highly sensitive optical channels. Powerful algorithms running on a Digital Signal Processor (DSP) are tuned to the characteristics of a fire and analyse the signals from these 3 channels to reliably identify fires. The detector offers sensitive flame detection over a long range with a wide and consistent field of view. Unlike some detectors the sensitivity of the array does not attenuate across its 90⁰ field of view eliminating the need to over-

detector suitability

lap detector coverage, thereby reducing the number of detectors required compared to other types. It also has excellent immunity to false alarms. Masking within a field of view allows known hotspots to be removed eliminating potential false alarm sources.

This capability can be further enhanced by the inclusion, within the detectors housing, of a CCTV camera which will connect over a twisted pair to a proprietary CCTV system and which transmits live images of the detectors field of view.

These detectors can be used to protect large open areas without sacrificing speed of response to flaming fires. In order to ensure full coverage however, flame sensors do require direct line of sight to all parts of the area to be protected.

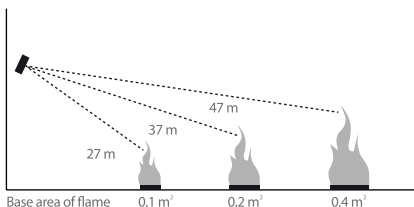

Fig. 11 Flame detector typical response characteristics (centre line range against petrol flames)

The detectors are designed to respond rapidly to fires that involve clean burning fuels such as alcohol or methane, that is fires that would not be detected by the use of smoke detectors or carbon monoxide fire detectors (see Table 1).

For flaming fires, flame sensors are probably the most sensitive. The sensitivity of flame detectors can vary considerably. Normally they should be able to detect a 15cm high flame at a range of between five and ten metres. They will detect a 0.1m² petrol fire at 27m on the centre line, within approximately 10 seconds. An 0.2 m² fire is detectable at 30 metres and an 0.4m² fire at 47 metres. The flame height is roughly proportional to the range (see Figure 11).

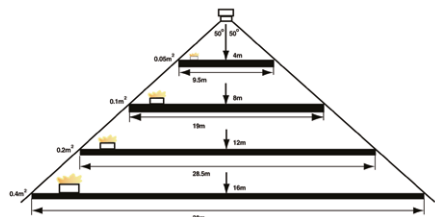

Fig 11 a Coverage of point type flame detector

detector suitability

As infra-red flame detectors cannot respond until there is flame, it is considered practical to also use smoke detectors or carbon monoxide fire detectors in conjunction with flame detectors in areas where the contents are likely to smoulder in the event of fire. In the case of smouldering fires, smoke and carbon monoxide is very often produced long before flaming occurs. Consequently, the smoke or carbon monoxide detectors should cause the system to go into alarm before flaming can start. Conversely, if the contents are highly flammable, the flame detectors should cause the system to go into alarm before the smoke detectors or carbon monoxide detectors can detect the fire.

5.2.5 Optical Beam Detectors

Optical beam detectors must conform with the requirements of BS EN 54-12.

Optical beam detectors consist of two units, a Transmitter and a Receiver, which are displaced some distance apart (10 metres to 100 metres).

Alternatively the transmitter and receiver are combined into a single unit and a reflector is used to bounce the transmitted beam back to the receiver.

This type of detector is specifically designed for interior use in large open-type areas, such as warehouses, manufacturing plants,

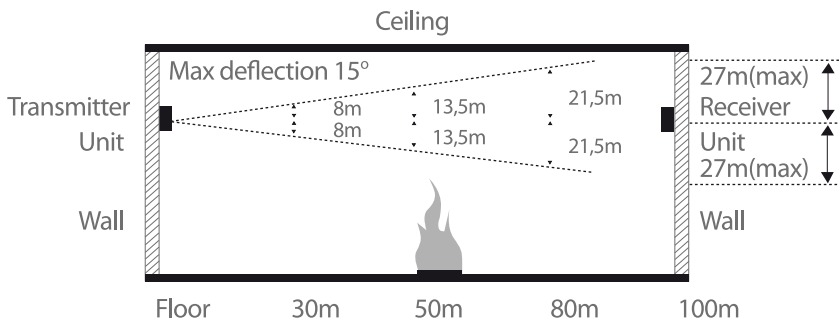

fig 12. Beam detector deflection characteristics (Vertical plane view)

detector suitability

aircraft hangers, workshops, etc. where the installation of point-type detectors would be difficult. They are also ideally suitable for installation in art galleries, cathedrals, etc. where, due to ornate and historic ceilings, point-type detectors and their associated wiring would be unsuitable.

During operation, the transmitter unit projects a modulated infra-red light beam directly at the receiver unit. The receiver unit converts the received light beam into a signal which is continuously monitored by the detector. If fire breaks out in an area protected by these detectors, smoke particles rising upward interrupt or partly deflect the light beam thus reducing the strength of beam received by the receiver unit

(see Figures 12). If the signal in the receiver unit, which proportionally represents the strength of received light beam, is reduced by between 40 and 90 % for a period greater than five seconds (approximately), it causes the system to go into alarm.

For correct operation the transmitter and receiver units must be mounted in the roof space or just below the ceiling, whichever is applicable.

Each detector is capable of protecting an area 7.5 metres each side of the beam centre line for a distance of up to 100 metres, thus providing a total coverage of up to 1500 square metres (see Figure 13).

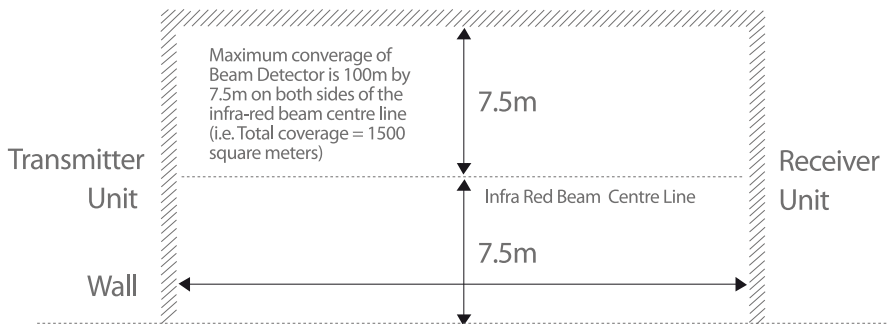

fig 13. Beam detector coverage characteristics (Horizontal Plane View)

detector suitability

The transmitters and receivers shall be mounted on solid construction that will not be subject to movement, otherwise fault signals or false alarms can occur.

Where reflective type beam detectors are used, the preferred beam type smoke detector would have an integral auto aligning feature, designed to realign the unit with its reflector if due to building movements the two components are misaligned. The feature is also an aid to the initial installation and commissioning

Sometimes in buildings with very high spaces, such as an atrium, optical beam detectors are mounted much lower than the highest point within the space. The reason for this is that, as the plume of smoke rises, it cools and will level out when it reaches ambient temperature. This effect, which is known as stratification, may occur well below the highest point within a tall space, so seriously delaying operation of a detector at the highest point.

Unfortunately, it is never possible to predict exactly where stratification will occur. If the beam of an optical beam detector runs at a much lower level than that at which stratification does occur, the relatively narrow rising plume of smoke may by-pass the beam. For this reason, the low

level beam detectors should only be regarded as supplementary to detection at the highest point in the space.

BS 5839-1 gives guidance on the siting of these supplementary beam detectors, taking into account that the plume does spread out as it rises. Accordingly, the code recommends that the width of the area protected on each side of a supplementary optical beam should be regarded

section one | guide to design, installation, commissioning and maintenance of fire systems in non domestic premises

detector suitability

as 12.5% of the height of the beam above the highest likely seat of fire. For example, if the supplementary beam detectors were mounted 10m above the base of an atrium, optical beam detectors would need to be sited every 2.5m across the width of the atrium (see Figure 14).

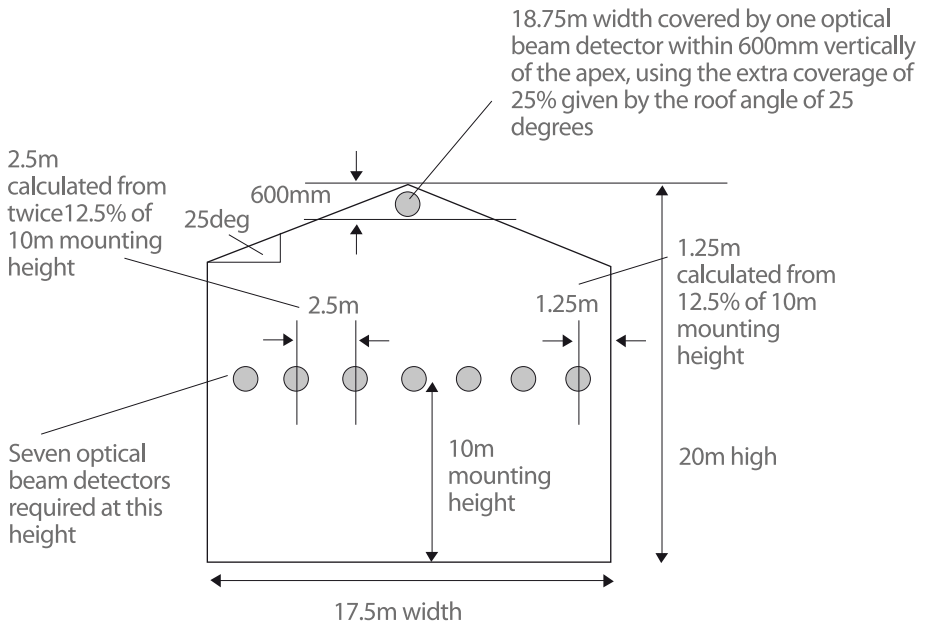

fig 14. Sitting of supplementary optical beam detectors

detector coverage

Atria and other similar roof spaces present particular challenges for smoke detection. Some of the challenges that designers face are

- Difficult access for detector installation, maintenance, testing and replacement
- Exposure to direct sunlight
- Multiple reflective surfaces causing false alarms
- Building movement
- Multi-level detection
- Aesthetics

Open Area Smoke Detection Imaging (OSID) overcomes the weaknesses of some beam detectors due to its aesthetics and multi-emitter capability, providing 3D coverage of the area.

A system can consist of up to seven Emitters and one Imager placed on opposite walls, roughly aligned with one another. Emitters are battery-powered or wired and can be placed at different heights, adjusting easily to modern design of atria. Three Emitters will cover an area of up to 600m²; five Emitters and up to 2,000m² all using just a single 80-degree Imager. In addition, OSID offers many advantages over traditional beam smoke detectors, the primary one being the use of dual light frequencies. Ultraviolet (UV) and infrared (IR) waveleng-

ths assist in the identification of real smoke compared to larger objects such as insects and dust, thus reducing false alarms. Furthermore, OSID is equipped with a CMOS imaging chip with many pixels rather than a single photo-diode. This concept allows the Imager to provide simple alignment as well as excellent tolerance to building movement and vibration, without the use of moving parts.

OSID's provide new levels in stability and sensitivity while providing greater immunity to high-level lighting variability, allowing OSID to provide extra stability in sunlit areas like atria.

Optical beam detectors must conform with the requirements of BS EN 54-20.

5.2.6 Aspirating Detectors

Aspirating detectors comprise a small pump which draws samples of the room air through holes in the system pipework into a detector element. The tube can be split into several smaller tubes (each drawing samples of air from different locations) or have several holes and through which air samples can be drawn (see Figure 15).

detector coverage

To allow for the effects of dilution of smoke, the detector element of an aspirating detector can indicate that smoke is present in the air (30% of the detectors range), and the

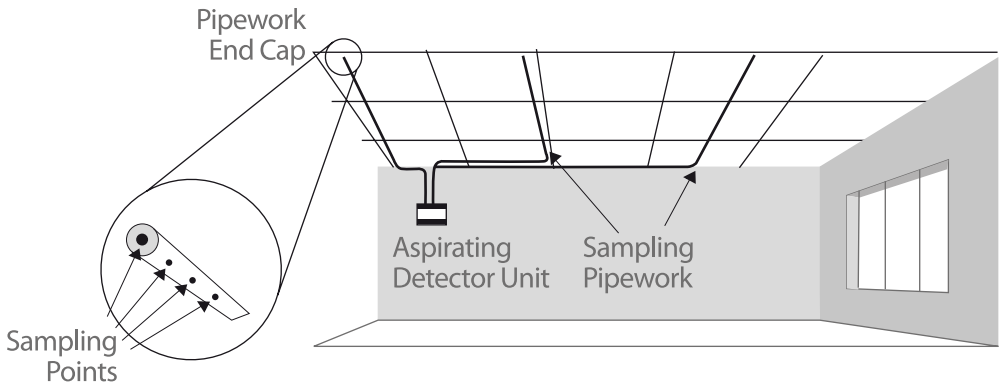

fig15. Aspirating detector ceiling mounted pipework

detector is usually up to 100 times more sensitive than that of conventional point and line-type detectors. The air being sampled is often passed through a filter before being analysed for the presence of smoke.

The detector provides a number of outputs, each of which relate to a different density of smoke contained in the air being sampled. It is normal practice to monitor at least two outputs from each detector. One

other that fire is present (60% of the detectors range). These outputs can be reported on separate zones of a conventional fire system control panel but it is more appropriate for the outputs to be connected to two address points in an addressable fire system.

These detectors are particularly useful for protecting computer suites and clean rooms. The use of aspirating systems for this

detector coverage

purpose is discussed in BS 6266. Commonly, in this situation, the aspirating system is not used to provide the general fire detection throughout the space (which often takes the form of normal point smoke detectors), but the system is used to monitor the return flow to air conditioning units in the protected space. The intention is to detect the very small amounts of combustion products transported within the conditioned air within the room. These are also used for the protection of historic buildings where point or line-type detectors would look out of place.

In this case, the pipework can be concealed above a ceiling, and small sampling tubes are dropped through small holes in the ceiling to provide virtually invisible fire detection.

A more recent development in some aspirating systems is the introduction of gas detection through the same system of pipe work as that used for the fire detection. The system is designed to detect a range of flammable, toxic and oxygen gas hazards and can provide a greater area of coverage than fixed point gas detection systems. The system is for use indoors in non 'Hazardous' classified areas only. The gas detector(s) have a sensor cartridge containing 1 or 2 gas sensors using

industry proven electrochemical & catalytic sensors. Amongst the detectable gases are, Carbon Monoxide, Nitrogen Dioxide, Ammonia, Oxygen, Sulphur Dioxide, Hydrogen Sulphide, Hydrogen, Methane and Propane. Other gases can be added on request. The system can be integrated to third party systems as there are various protocols available, including 4-20mA and modbus. As gas detectors require regular calibration the system incorporates an advanced warning that this is due. All detectors have a finite life depending upon their structure which may vary between 18 months and 5 years. Typical applications are, where aspiration systems are normally used for fire detection and where gas detection may also be required these would include UPS and battery charging rooms, cable tunnels and vaults, service tunnels, underground parking and loading bays.

The Fire Industry Association (FIA) publish a detailed code of practice for aspirating detection systems.

5.2.7 Duct Probe Unit

The duct probe unit is a detector which has been designed for use in situations where the standard smoke, heat and flame types cannot be used. Primarily, it is used for detecting the presence of smoke or combus-

detector coverage

tion products in extract ventilation ducting systems. The detector operates in a similar way to aspirating detectors except it does not contain a pump. Instead, it is designed to operate on the venturi effect in the sampling pipe providing optimum airflow through the smoke detector. (see Figure 16).

The unit is especially recommended for installations in ducts with low airflow. The system fulfils all the requirements for safe fire detection with airflow speeds from 0,5 m/s to 20 m/s.

The length of the venturi pipe shall be chosen based upon how wide the ventilation duct is. The venturi pipe is available in 3 lengths; 0,6, 1,5 and 2,8 m. When the ventilation duct is wider than 0,6 m, the venturi pipe should penetrate the whole duct. The probe is flow direction sensitive and must be fitted accordingly. The air in the sampling chamber is analysed for the presence of smoke particles, and if found, the unit signals this condition to the control panel.

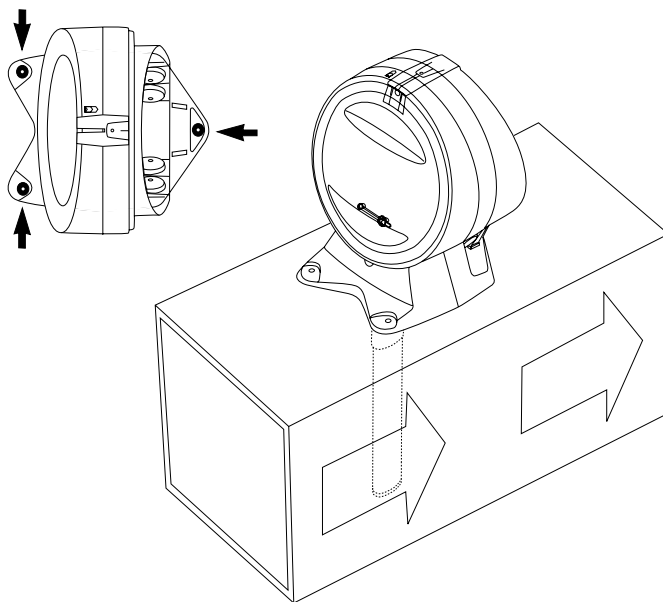

fig16. Duct probe unit installed in return air duct

detector coverage

6. Detector Coverage

Clause 22 of the code describes where detectors should be sited and what spacing should be used. Most of the recommendations of clause 22 are common for all Categories of system. In a few cases, however, a recommendation varies, according to the Category of system.

6.1 Spacing Under Flat Ceilings

In open spaces under flat horizontal ceilings, every point should lie within a horizontal distance of 7.5m from a smoke detector

or 5.3 m from a heat detector [22.3 a)]. In simple terms, this means that each point within the protected area must be covered by at least one detector; the coverage of a detector is a circle centred on the detector and having a radius of 7.5m for smoke detectors and 5.3 m for heat detectors. For beam detectors, the horizontal distance should be taken to the nearest point on the infra-red light beam, and the coverage should be taken as extending to that distance on both sides of the centre line of the beam see Figure 17 below).

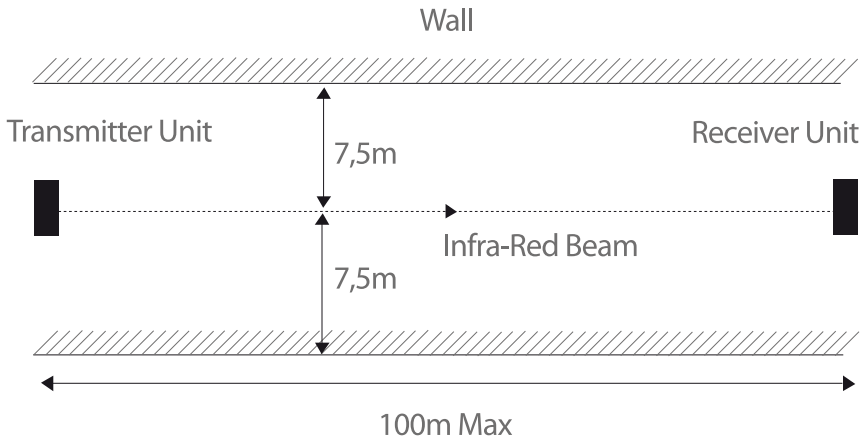

Beam Detector Spacing

section one | guide to design, installation, commissioning and maintenance of fire systems in non domestic premises

detector coverage

The sensitive elements of smoke detectors should normally lie within the range of 25mm to 600mm from the ceiling, and for heat detectors within the range of 25mm to 150mm.

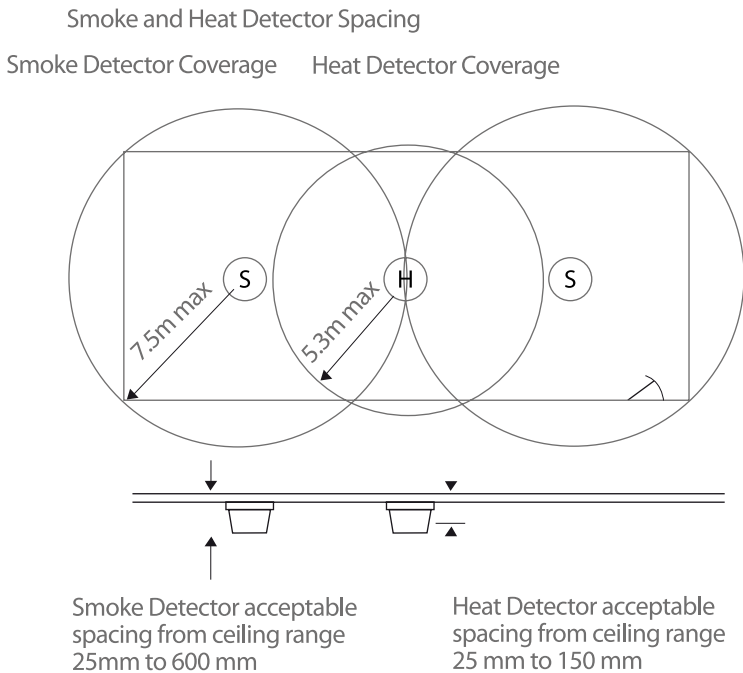

fig 17. Detector coverage and spacing under flat ceilings

detector coverage

6.2 Spacing Under Pitched Ceilings

If the ceiling is pitched, sloping or north-light, and the difference in height between any apex and an adjacent valley or low point of the ceiling exceeds 600mm for smoke detectors or 150mm for heat detectors, then detectors should be placed in or near the apex. (A detector may be regarded as 'near' the apex if the vertical distance from the apex to the detector

is not greater than the above figures.) If the differences are less than that quoted, then the ceiling can be considered as flat. For the row of detectors mounted in or near the apex, the radius of cover can be increased by 1% for each degree of slope up to a maximum of 25% [22.3 b)] (see Figure 18 below).

For a semi cylindrical arch or a hemispherical dome, the radius of cover of a de-

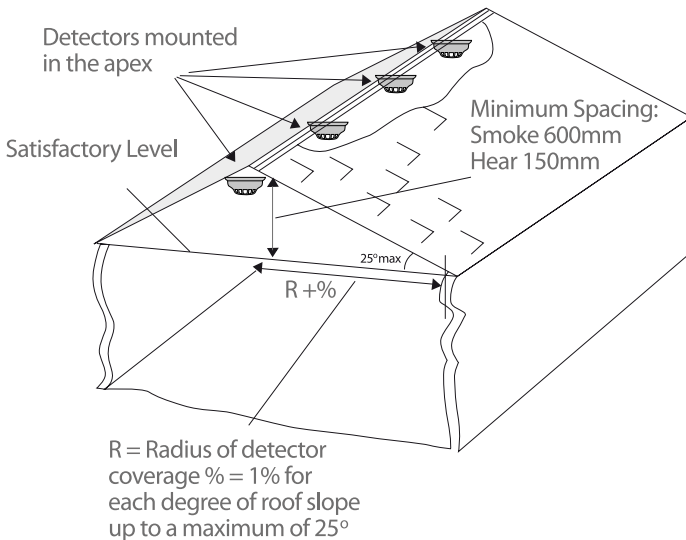

fig18. Detector coverage for pitched

detector coverage

detector in the centre can be calculated as 8.93m for a smoke detector and 6.31m for a heat detector.

6.3 Spacing in Corridors

In the past, designers have often applied the recommendations for the maximum distance between any point and the nearest detector with unnecessary accuracy, so that, for example, the 7.5m dimension was deemed to be the maximum distance between any point on the ceiling adjacent to the wall of the corridor and the nearest detector. This led to unnecessarily complex tables for spacings between detectors in corridors, according to the corridor width.

Since fires do not constitute point sources and the plume of gases spreads as it rises, this approach is now regarded by BS 5839-1 as unnecessarily purist. Accordingly, in corridors of no more than 2m in width, the code considers only the distance between points close to the centre line of the corridor and the nearest detector. The effect of this is that, in these corridors, smoke detectors can be spaced 15m apart, while heat detectors (e.g. in a Category P system) can be spaced 10.6m apart. In corridors wider than 2m, the approach to detector spacing should be the same

as that adopted in other areas, namely that the maximum distance between any point (along the boundary wall of the corridor) and the nearest detector should be no more than 7.5m in the case of smoke detectors and 5.3m in the case of heat detectors.

6.4 Stairways

In enclosed stairways, fire detectors should be sited at the top of the stairway and on each main landing.

An open stairway forms a path for vertical spread of smoke and fire. It is desirable to detect products of combustion before they pass up the stairway and as they pass out of the stairway. For this reason, a fire detector should be sited at the top and, on each level, within approximately 1.5m of the floor penetration. This protection is, however, only required in the areas protected by the Category of system in question. It is not necessary in the case of a Category L4 system and may not be required in the case of a Category L5 or P2 system, although the designer should always consider the provision of these detectors in the latter two systems.

detector coverage

6.5 Lift Shafts and Other Flue-like Structures

Shafts for lifts, escalators or hoists, and any enclosed chutes, should be treated like open stairways. Thus, again, in areas protected by the Category of system in question, a detector should be sited at the top of the shaft or enclosure and, on each level, within approximately 1.5m of the penetration of the floor. Although not necessary in

a Category L4 system, this form of protection should be considered by the designer in the case of a Category L5 or P2 system, albeit that it may not always be necessary.

6.6 Obstructions

Ceiling obstructions, such as structural beams, deeper than 10% of the overall ceiling height should be treated as walls. The area on each side of the obstruction

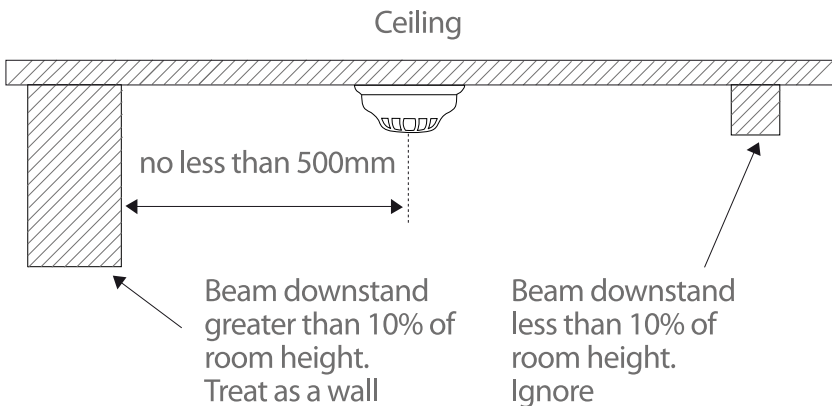

fig 19. Ceiling Obstructions Treated as Walls

detector coverage

should, therefore, be regarded as a separate area for the purpose of protection. The same applies in the case of partitions or storage racks that extend within 300mm of the ceiling (See Figures 19 and 20).

Where structural beams, ductwork, lighting fittings or other fixings to ceilings, not greater than 250mm in depth, create obstacles to the flow of smoke, detectors should not be mounted closer to the obstruction than twi-

ce the depth of the obstruction. (See Figure 21) Where obstructions, such as structural beams and ductwork, are greater than 250mm in depth, detectors should not be mounted within 500mm of the obstruction.

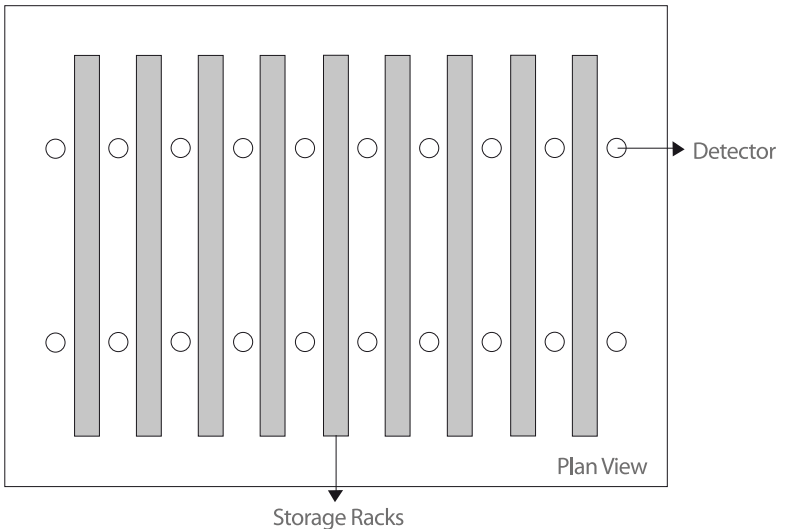

fig 20. Partitions or Storage on Racks

detector coverage

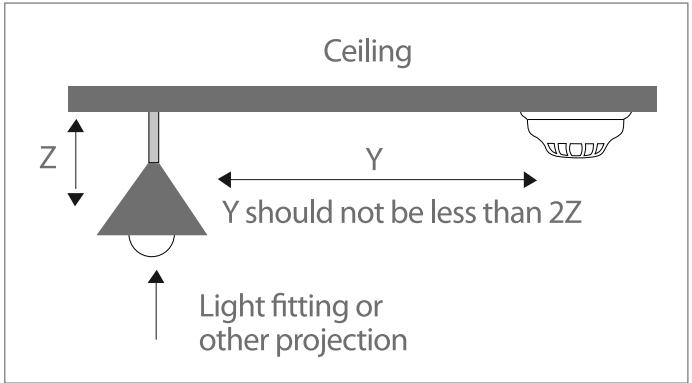

fig 21. Proximity of Detectors to Ceiling Fittings

6.7 Honeycomb Ceilings

Where a horizontal ceiling comprises a series of small cells, often referred to as a

honeycomb ceiling, detector spacing and siting should be in accordance with Table 4. (See Figure 22).

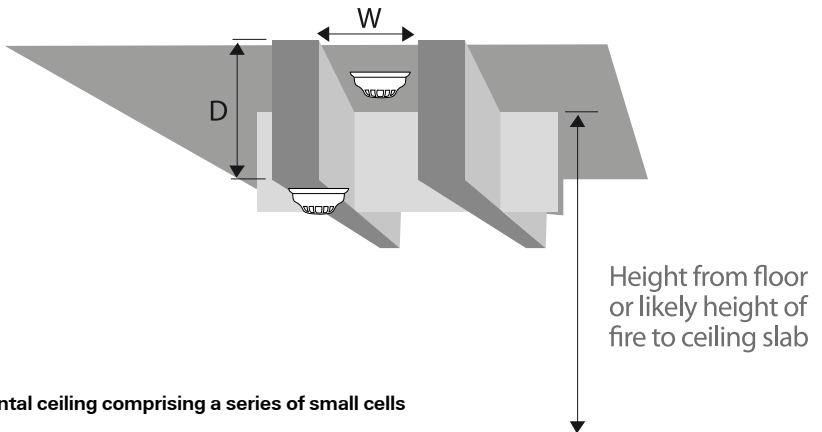

fig 22. Horizontal ceiling comprising a series of small cells

section one | guide to design, installation, commissioning and maintenance of fire systems in non domestic premises

detector coverage

Overall ceiling height from floor into cell (H) (to nearest whole metre)	Beam depth (D)	Maximum distance between any point and the nearest smoke (heat) detector	Detector location if W is 4 D or less	Detector location if W is more than 4 D
6m or less	less than 10% H	As per flat ceilings	Underside of beams	On structural slab in the cell
more than 6m	less than 10% H and 600mm or less	As per flat ceilings	Underside of beam	On structural slab in the cell
more than 6m	less than 10% H and more than 600mm	As per flat ceilings	Underside of beams ⁹	On structural slab in the cell
3m or less	more than 10% H	4.5m (3m)	Underside of beams	On structural slab in the cell
4m	more than 10% H	5.5m (4m)	Underside of beams	On structural slab in the cell
5m	more than 10% H	6m (4.5m)	Underside of beams	On structural slab in the cell
6m or more	more than 10% H	6.5m (5m)	Underside of beams	On structural slab in the cell

KEY: W = Width of cell D = Depth of beams that form each cell

⁹ Since mounting detectors at a depth of more than 600mm below the highest point in the protected spaces does not comply with 22.3d, protection in these circumstances might need careful consideration to determine the most suitable location and spacing of detectors.

table 4. Spacing and Siting of Detectors

6.8 Closely Spaced Structural Beams and Floor Joists

Where there are a number of closely spaced structural beams, such as floor joists, a series of reservoirs for smoke, which BS 5839-1 refers to as 'cells', occur. Provided that the longer dimension of the cells is no more than L, then across the shorter cell dimension, the spacing, M, between detectors should be as given in Table 5. The spacing for the end detector to the end wall is half M. Detectors should be in the centre of

the cells. If the longer dimension of the cells is more than L (see below), then the cell should be stopped to the depth of the beam and at no more than L. If this is impractical, detection should be installed in every cell. See Figure 23.

L = 10.6m for smoke detectors.
L = 7.5m for heat detectors.

detector coverage

Overall ceiling height from floor to structural slab (to nearest whole metre)	Beam depth	Maximum distance between any two smoke (heat) detectors measured across the beams
H	D	M
6m or less	less than 10% H	5m (3.8m)
more than 6m	less than 10% H and 600mm or less	5m (3.8m)
more than 6m	less than 10% H and 600mm or less	5m (3.8m)
3m or less	more than 10% H	2.3m (1.5m)
4m	more than 10% H	2.8m (2m)
5m	more than 10% H	3m (2.3m)
6m or more	more than 10% H	3.3m (2.5m)

table5. Spacing and siting of detectors on ceilings with closely spaced structural beams or joists.

detector coverage

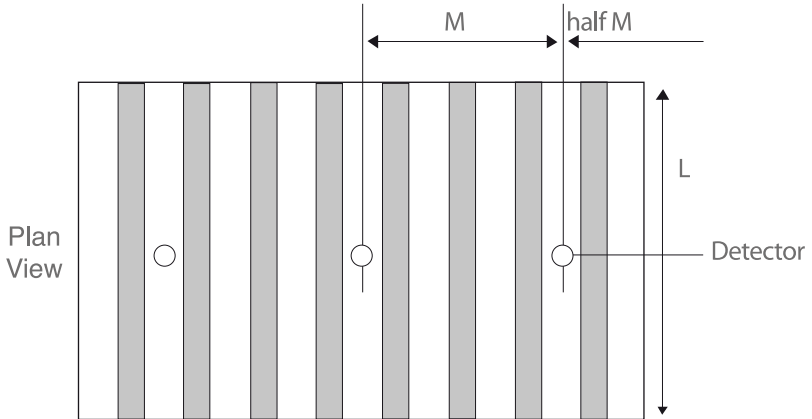

In this example beam downstands are greater than 10% of ceiling height, H . $H = 3\text{m}$. Smoke detectors are used in this example. Using table 5, the spacing, M should be no more 2.3m

fig 23. Cells formed from joists

6.9 Ceiling Heights

Detectors should not generally be mounted on ceilings higher than those listed under in column one in Table 6 below. However, if small sections of ceiling, not exceeding in total 10% of the ceiling area within the protected area, exceed these limits, these higher sections are adequately protected provided that the ceiling height does not exceed the limits in column two Table 6.

detector coverage

Table 3 Limits of ceiling height

Detector Type	Column 1 Generally applicable maximum ceiling height	Column 2 Max ceiling height for 10% of ceiling area
Heat Detectors (BS EN 54-5):		
Class A1	9.0	10.5
Other Classes	7.5	10.5
Point smoke detectors (BS EN 54-7)		
	10.5	12.5
Carbon monoxide detectors (BS EN 54-26)		
	10.5	12.5
Optical beam smoke detectors (BS EN 54-12)		
Normal sensitivity	25.0	28.0
Enhanced sensitivity (alarm at 35% attenuation or less)	40.0 (See Note1)	43.0 (See Note1)
Aspirating smoke detection systems (BS EN 54-20)		
General limit	10.5	12.5
Class C with at least 5 holes	15.0	18.0
Class C with at least 15 holes	25.0	28.0
Class B with at least 15 holes	40.0 (See Note2)	43.0 (See Note2)
Other fire detectors	As specified by the manufacturer	

NOTE 1 The use of supplemental detection is recommended [see 22.5d)] unless the risk (i.e. probability × consequence) of stratification is minimal.

NOTE 2 The use of multilevel sampling is recommended [see 22.7c)] unless the risk (i.e. probability × consequence) of stratification is minimal.

detector coverage

6.10 Walls and Partitions

A wall has two effects on the movement of smoke under a ceiling:

1. It slows down its movement towards the wall.
2. It deflects it in a direction parallel to the wall.

Because of the slowing down effect, there tends to be dead spots near the wall. The code therefore states that detectors should not be mounted within 500mm of any wall or partition. (Sections of the optical beam of an optical beam detector closer than 500mm to a wall or partition should be discounted from providing fire detection).

Detectors within rooms that open onto escape routes in a Category L3 system may be sited in the normal manner. However, as a special relaxation for these detectors only, the detectors may be sited on a wall, close to any door that opens onto an escape route. Wall mounted detectors should be sited such that the top of the detection element is between 150mm and 300mm below the ceiling, and the bottom of the detection element should be above the level of the door opening. However, in rooms with a high ceiling (e.g. exceeding 4m in height), a variation might need to

be considered, so that the detector will operate before the door is under serious attack by fire.

6.11 Voids

Ceiling and under-floor voids 800mm or more in height should also be protected by detectors. (Occasionally, however, a variation, whereby detectors are omitted, might be considered in the case of voids in which the fire risk is low and the void is not a route for fire spread beyond the room of origin). Any void less than 800mm in height need not be protected unless extensive spread of fire or its products, particularly between rooms or compartments, can take place within it before detection or, on the basis of a fire risk assessment, protection is considered to be warranted.

Where it is considered necessary to install detectors in shallow voids having poor ventilation, for example under-floor service voids, special care should be taken with the positioning of the detectors. As the initial smoke layer in a fire usually takes up the top 10% of the void height, in shallow voids this may be small compared with the dimensions of the detector. Care should therefore be taken to ensure that the sensing element of the detector lies within the top 10% of the void's height or the top 125mm, whichever is greater.

detector coverage

6.12 Perforated Ceilings

Detectors above a perforated false ceiling may be used for protection of the area below the false ceiling if:

- 1) The perforations are substantially uniform, appear across the complete ceiling and throughout they make up more than 40% of the surface; and
- 2) The minimum dimension of each perforation in any direction is 10mm; and
- 3) The thickness of the ceiling is not greater than three times the minimum dimension of each perforation.

In all other cases, detectors should be mounted below the false ceiling, and if protection of the void above the false ceiling is necessary, further detectors should be installed on the true structural ceiling within the void.

6.13 Ventilation

Ventilation systems in buildings should also be taken into account when designing fire systems because air movements in a space can have a number of effects on the operation of the devices.

Extraction systems can draw the fire products away from normally sited detectors, and fresh air inlets can stop clean air passing over detectors even when the room air is smoky. Increased air turbulence can give increased dilution of the smoke, and, in the case of ionization smoke detectors, clean air can cause a false alarm if it is moving fast enough.

All heat and smoke detectors depend on the movement of fire products from the fire to the detector. Movement of air in the building may be due to many causes, all of which can have an effect on the movement of the fire gases. As the fire gets bigger its convective effects gradually overpower all other causes of air movement. This, however, is not of much use to us as we need to detect fires when they are small.

Computer Suites are a case of special importance lies in the protection of computer suites. These usually combine a high financial value with high ventilation rates; just when we need to detect fires particularly quickly, the ventilation makes things especially difficult! BS 6266 (Code of practice for fire protection for electronic equipment installations) should be consulted here.

Ventilated Rooms the code provides useful advice on installation of detectors in venti-

detector coverage

lated rooms 22.3m. Detectors should not be mounted directly in the fresh air input from air conditioning systems. In general, a spacing of not less than 1m between the detector and the air inlet should be maintained. Where the air inlet is through a perforated ceiling, the ceiling should be non perforated for a radius of at least 600mm around each detector.

Smoke Detectors in Ventilation Ducts Sometimes, smoke detectors are installed within air extraction ducts. These detectors cannot give adequate protection of the area from which air is extracted, as the extraction system may be shut down at certain times. However, they are sometimes installed as supplementary protection (e.g. to shut down recirculation of air). The detector may be mounted outside the duct, with a probe (see 5.2.7) extending into the duct itself. The smoke detectors or probes should be installed in straight stretches of ductwork, at a distance from the nearest bend, corner or junction, of at least three times the width of the duct. Only detectors deemed suitable for this application by the manufacturer should be used. Normally, a duct probe should cover the wider dimension of the duct, and the length of the probe should be at least two-thirds of that dimension.

6.14 Lantern-lights

A lantern-light or cupola can form a reservoir for smoke. If it is used for ventilation, it also forms a chimney, through which smoke will flow. BS 5839-1 recommends that if any lantern-light within a protected area is 800mm or more in depth, or is used for ventilation, a fire detector should be sited in the lantern-light.

manual “break glass” call points

7. Manual “Break Glass” Call Points

7.1 General Information

All Category L1, L2, L3 and L4 systems must include call points, so that, in the event of a fire, people can raise the alarm immediately. In practice, usually Category L5, P1 and P2 systems also incorporate manual call points, unless these are provided in a separate system. Manual call points should conform to BS EN 54-11. ‘Type A’ call points, in which only a single action is necessary to raise the alarm (i.e. breaking the glass) should be used. However, subject to the agreement of the enforcing authority, a hinged, transparent cover may be used if the call points are likely to be subject to casual malicious operation. (See Section 8).

All call points in the installation must have the same method of operation unless there is a special reason for differentiation. A system in which some call points require impact by a hammer and others just require thumb pressure is not acceptable.

The delay between operation of a call point and the sounding of the alarm should not exceed three seconds.

Normal break glass call points might not be acceptable in food preparation areas or areas where particularly explosive atmospheres are likely to be present. If installed in food preparation areas, breaking the frangible element may result in glass fragments getting into food.

7.2 Siting of Manual Call Points

The basic principle of manual call point siting is that no one should be able to leave a building, or a storey of a building, without passing a manual call point. BS 5839-1 recommends that manual call points should be located on escape routes and, in particular, at all storey exits and all exits to open air. Note that, in the case of exits to open air, these may, or may not actually be designated as fire exits.

In the case of manual call points located at storey exits, the code offers a choice of siting. The manual call points may either be located on the staircase landings or within the accommodation, adjacent to the door to the stairway. However, in a multi-storey building with phased evacuation, the two options for manual call point siting are not given by the code; in this case, manual call points should not be located on stairway landings. Where horizontally adjacent areas may be evacuated separately in

manual “break glass” call points

a building with phased evacuation, the code recommends that additional manual call points are provided to ensure that one manual call point is located at every designated exit from an alarm zone; unless this recommendation is satisfied, the appropriate areas might not be evacuated in the first phase.

The code sets a limit on the maximum distance that anyone should have to travel to reach the nearest manual call point. Generally, this figure is 45m, but the figure is reduced to 25m where processes in the area result in the likelihood of rapid fire development (e.g. as a result of the presence of highly flammable liquids or flammable gases) or where a significant proportion of occupants have limited mobility and it can reasonably be anticipated that one of these occupants will first operate the fire alarm system in the event of fire.

At the design stage of the system, it may be difficult to actually measure, on drawings, the maximum distance that anyone will have to travel to reach a manual call point. For example, the final fit-out or layout of partitions, equipment, etc may not be known. In this case, the code recommends that sufficient manual call points be provided to ensure that the maximum straight line distance between any point in

a storey and the nearest manual call point does not exceed 30m (or 16m in situations in which the maximum distance of travel to a manual call point is limited to 25m). Ultimately, on completion of a system, however, it is the actual distance of travel to a manual call point, measured along the route that a person would actually follow, that matters; at that stage, the straight line distance does not matter.

Once the above criteria are satisfied, for compliance with the code the designer will need to ensure that, where specific equipment or activities result in a high fire hazard, a manual call point is sited in close proximity. Examples of such areas given in the code are kitchens or cellulose paint spray areas. As it happens, in both these cases, further special requirements might apply to the manual call points. For example, the cellulose spraying area might require the use of equipment certified for use in potentially explosive atmospheres. Within kitchens, it is possible that call points with non-glass frangible elements are necessary, although, in practice, such call points are more usually limited to food processing factories and the like.

The code recommends that manual call points are fixed at a height of 1.4m above fire

manual “break glass” call points

nished floor levels, at easily accessible, well illuminated and conspicuous positions free from potential obstruction. A ‘tolerance’ of 200mm in mounting height is permitted under the code without the need for it to be treated, or recorded, as a variation. The measurement should be made between the finished floor level and the centre point of the frangible element. Call points should be sited against a contrasting background to assist in easy recognition.

A mounting height lower than 1.4m is acceptable in circumstances where there is a high likelihood that the first person to raise an alarm of fire will be a wheelchair user.

Manual call points may be flush mounted in locations where they will be seen readily. However, where they will be viewed from the side, they should be surface mounted or only semi-recessed, such that the front face is proud of the mounting surface (e.g. the wall of a corridor) by at least 15mm.

limitation of false and unwanted alarms

8. Limitation of False and Unwanted Alarms

8.1 Role of the Designer

Section 3 of BS 5839-1 is devoted to limitation of false alarms. In the code, the designer is considered to be the key player in the limitation of false alarms. It is a specific recommendation of the code that the system designer should ensure that the system design takes account of the guidance contained in Section 3 of the code. The certificate of compliance that the designer must complete not only certifies that the design complies with Section 2 of the code, it also certifies that account has been taken of the guidance in Section 3. More specifically, the design certificate contains various tick boxes that the designer must consider and tick as appropriate to indicate which of various specific actions have been taken within the design to ensure that false alarms are limited. A further informative annex sets out in schematic form the thought processes involved in ensuring that system design is sufficiently immune to false alarms (See Figure 24).

The code considers the role of the installer in limiting false alarms as much less significant. The logic is that the role of the installer is simply to install the system in

accordance with the requirements of the designer. However, the code recommends that a special check is carried out as part of the commissioning process to ensure that there is no obvious potential for an unacceptable rate of false alarms. Within the model certificate of commissioning, the commissioning engineer is specifically required to record that, taking into account the guidance in Section 3 of the code, no obvious potential for an unacceptable rate of false alarms has been identified.

The code suggests that it should be confirmed, before design begins, that automatic fire detection will be of a value that outweighs the potential for false alarms. In general, of course, this will be the case, but, in the case of some simple small buildings in which all areas are occupied on a 24 hour basis, automatic detection may be of little benefit to fire safety. Other than in such rare cases, it will, of course, be inappropriate to avoid fire detection as the means of limiting false alarms.

However, the code does advocate that, at the design stage, the designer makes at least a qualitative judgement as to the likely frequency of false alarms. In the case of very large systems with many smoke detectors, it might even be appropriate for the designer to provide the user with gui-

limitation of false and unwanted alarms

dance on the approximate rate at which false alarms could occur. This might then identify the need for incorporation of measures within the design to limit the number of false alarms; an example might be 'filtering measures', which are discussed later in this Section.

This quite onerous duty on the designer might, at first sight, appear somewhat theoretical, academic and idealistic. Certainly, it will hardly be appropriate for the designer of a fire alarm system for a small shop, which might comprise only two or three manual call points, half a dozen detectors and a few bells, to engage in dialogue with the user regarding the anticipated number of false alarms and special design measures for their avoidance! However, this guidance in the code is practical and sensible in the very large installations to which the guidance refers.

section one | guide to design, installation, commissioning and maintenance of fire systems in non domestic premises

limitation of false and unwanted alarms

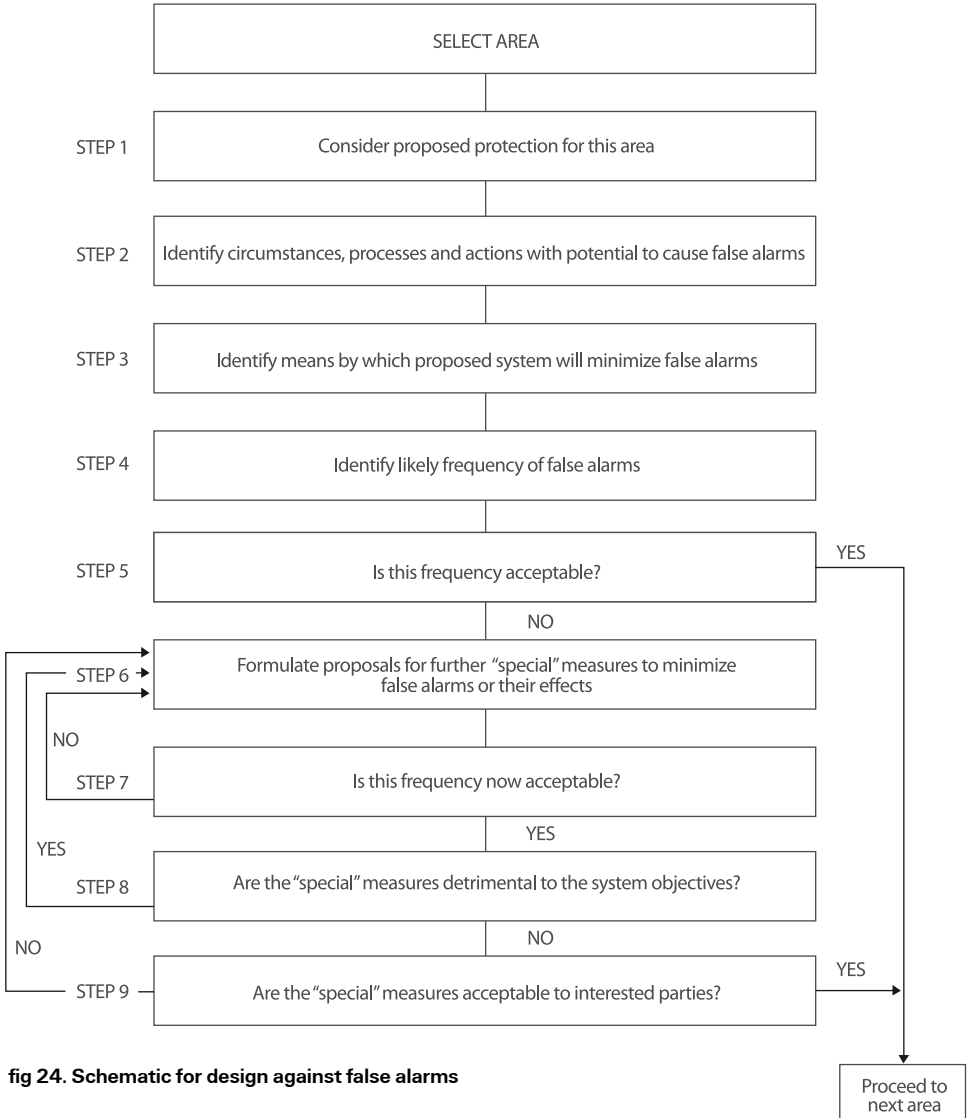

fig 24. Schematic for design against false alarms

limitation of false and unwanted alarms

8.2 Categories of False Alarm

The code recognizes four different categories of false alarm, albeit that the generic term 'false alarm' is used in the code to describe any fire signal resulting from a cause(s) other than fire.

The four categories of false alarms are described and defined as follows:

Unwanted alarms, in which a system has responded, either as designed or as the technology may reasonably be expected to respond, to any of the following:

A fire-like phenomenon or environmental influence (e.g. smoke from a nearby bonfire, dust or insects, processes that produce smoke or flame, or environmental effects that can render certain types of detector unstable, such as rapid air flow);

Accidental damage; Inappropriate human action (e.g. operation of a system for test or maintenance purposes without prior warning to building occupants and/or an alarm receiving centre);

Equipment false alarms, in which the false alarm has resulted from a fault in the system;

Malicious false alarms, in which a person operates a manual call point or causes a fire detector to initiate a fire signal, whilst knowing that there is no fire;

False alarms with good intent, in which a person operates a manual call point or otherwise initiates a fire signal in the belief that there is a fire, when no fire actually exists.

8.3 Requirements for Service Technicians

The code recommends that, at the time of every service visit, the system false alarm record should be checked carefully. The code identifies three matters that should be brought to light by this check.

Firstly, the rate of false alarms during the previous twelve months, expressed as number of false alarms per 100 detectors per annum, should be determined by the service technician. Secondly, it should be determined whether, since the time of the previous service visit, two or more false alarms, other than false alarms with good intent, have arisen from any single manual

limitation of false and unwanted alarms

call point or fire detector (or detector location). Thirdly, it should be determined whether any persistent cause of false alarms can be identified from a study of the false alarm log. As part of the service work, a preliminary investigation should be carried out if any one or more of four circumstances is found to apply, namely:

- 1) The rate of false alarms over the previous twelve months has exceeded one false alarm per 25 detectors per annum.
- 2) More than eleven false alarms have occurred since the time of the previous service visit (i.e. typically, within the previous six months).
- 3) Two or more false alarms (other than false alarms with good intent) have arisen from any single manual call point or fire detector (or detector location) since the time of the last service visit.
- 4) Any persistent cause of false alarms is identified.

8.4 False Alarm 'Rates'

The code advises that systems in which the parties responsible have not taken adequate care to limit false alarms, and systems that produce unacceptably high rates of false alarms, need to be regarded as non-compliant with the code. Such a non-compliance could bring with it civil liability and implications for insurance of the property, as well as possible enforcement action by enforcing authorities. Indeed, the code notes that, in the future, it is possible that a fire authority will take appropriate action if a fire alarm system consistently produces false alarms at unacceptable rates.

This, therefore, introduces the concept of an 'acceptable' rate of false alarms. The code is realistic enough to acknowledge that, while any false alarm is undesirable, it must be accepted that, particularly in installations that incorporate a large number of automatic fire detectors, complete elimination of false alarms is impossible. The best that can be expected is that the rate of false alarms from any installation falls within limits defined as 'acceptable'.

Factors that will affect the number of false alarms include the environment (including the electromagnetic environment), activities in the building, the level of occupation

limitation of false and unwanted alarms

of the building and the standard of management in the building, the latter of which will affect matters such as control over third parties, (e.g. contractors), and the potential for malicious operation of manual call points.

However, the code suggests that a key factor will be the number of automatic fire detectors in the installation. Thus, the code advises that the number of false alarms that can be anticipated is virtually proportional to the number of automatic fire detectors installed.

This is because each detector can be considered as a potential generator of false alarms as a result of environmental factors and activities within the area of the detector, as well as, of course, the possibility of a detector fault. The code notes that the ratio of false alarms to number of detectors in the installation will depend on the extent to which smoke detectors are used; systems that are purely manual, or in which heat detectors are used, should not normally produce many false alarms.

As a guide, the code suggests that, in a relative benign environment, in which there is no tendency for dust, fumes or insects to occur, and in which there is a good standard of management, false alarm rates equal to,

or less than, one false alarm per 100 detectors per annum are possible. While this figure is not intended as a norm or 'average', it might, therefore, be regarded as an ideal target for false alarm management under ideal conditions. A more realistic expectation on industrial sites with shift working is suggested by the code to be one false alarm per 75 detectors per annum.

The code does not, however, suggest that the above figures are easily achievable. On the other hand, it does suggest that, in general, false alarm rates of one false alarm per 50 detectors per annum can be readily achievable with modern technology systems, unless there are severe environmental challenges for automatic fire detection. There is a tentative suggestion in the code that this rate might, therefore, be quite reasonable and 'acceptable' on an industrial site with processes that create an unfavourable environment for automatic fire detectors.

On the other hand, it is suggested that this rate might not be 'acceptable' in a controlled environment, such as a computer room.

These figures now provide the user with some form of target, however imprecise it might be, at which to aim in any initiative

limitation of false and unwanted alarms

to reduce false alarms. However, the lack of precision in these figures, and the number of variables that will affect the actual false alarm rate in any specific installation, are such that it would not be reasonable to deem the rate of false alarms as unacceptable simply because these particular figures are not reached. Nevertheless, since the code introduces the concept of an 'unacceptable rate of false alarms', there must be some (much higher) rate of false alarms that does not simply fall short of the possible target ideal, but that is quite positively unacceptable.

The code defines such a level. The advice given is that, in general, in systems with more than 40 automatic fire detectors, a rate of more than one false alarm per 20 detectors per annum is never to be regarded as acceptable, particularly if the false alarms result in evacuation of the premises or summoning of the fire service. In premises with 40 automatic fire detectors or less, more than two false alarms per annum is to be regarded as unacceptable. It is these figures that are, therefore, used as the basis for the 'trigger' at which an in-depth investigation by suitable specialists should be carried out.

Specifically, the code recommends that, in systems that incorporate more than 40 au-

tomatic fire detectors, the user should instigate an in-depth investigation by suitable specialists if, in any rolling period of twelve months, either:

- 1) The average rate of false alarms exceeds one false alarm per 20 detectors per annum; or
- 2) If three or more false alarms are initiated by any single manual call point or automatic fire detector (or detector location).

In systems that incorporate 40 or less automatic fire detectors, the in-depth investigation should be instigated by the user if, in any rolling twelve month period, three or more false alarms occur.

In 2010 CFOA (Chief Fire Officers Association) reintroduced a new policy for the reduction of false alarms and unwanted fire signals. The aim of this policy was to reduce the number of false alarms generated by fire detection and alarm system, and to reduce the number of UWFS (Unwanted Fire Signals) sent to F&RS (Fire and Rescue Systems).

The CFOA policy calls for a considerably better performance from automatic fire detectors than required by the code,

limitation of false and unwanted alarms

in respect of false alarms. It also recommends that the types of Call Filtering be adopted to help reduce false alarms calling the F&RS.

The policy also outlines methods of registering a fire detection alarm system together with possible reductions in F&RS attendance levels to repeat false alarm offenders. Full details on the policy can be found at www.cfoa.org.uk

8.5 Causes of False Alarms

The code lists 20 recognised causes of false alarms. These are as follows:

- Fumes from cooking processes (including toasting of bread);
- Steam (from bathrooms, shower rooms and industrial processes);
- Tobacco smoke;
- Dust (whether built up over a period of time or released from an industrial process);
- Insects;
- Aerosol spray (e.g. deodorants and cleaning fluids);
- High air velocities;
- Smoke from sources other than a fire in the building (e.g. from an external bonfire);

- Cutting, welding and similar "hot work";
- Processes that produce smoke or flame (e.g. flambéing of food);
- Cosmetic smoke (e.g. in discotheques and theatres);
- Incense;
- Candles;
- Electromagnetic interference;
- High humidity;
- Water ingress;
- Substantial fluctuation in temperature;
- Accidental damage (particularly to manual call points);
- Testing or maintenance of the system, without appropriate disablement of the system or warning to building occupants and/or an alarm receiving centre;
- Pressure surges on water mains serving automatic sprinkler systems that are interfaced with the fire alarm system.

The code acknowledges that most of these causes can be minimized by appropriate choice of detection system and suitable management arrangements.

Equipment false alarms, associated with faults in equipment, can, on the other

limitation of false and unwanted alarms

hand, be minimized by choice of good quality equipment that satisfies the appropriate product standards. Third party certification of the equipment provides a form of warranty of compliance. Once the equipment has been installed, regular servicing is important to ensure continuing satisfactory operation.

As noted in the code, the third category of false alarms, namely malicious false alarms, most commonly occur in certain public buildings, such as shopping centres, places of entertainment, certain public houses, public car parks and sports centres, and in educational establishments, such as universities and schools. These false alarms generally involve operation of manual call points.

The fourth category of false alarms, namely false alarms with good intent, is difficult to prevent and is, in any case, unlikely to present a significant problem. Moreover, it is generally undesirable to attempt to minimize false alarms with good intent, since the principles of fire safety dictate that it is entirely appropriate for people to raise the alarm, by operating a manual call point, if they suspect that there might be a fire. The code notes, therefore, that it is important that people are never discouraged from doing so.

8.6 Practical Measures to Limit False Alarms

One entire clause (clause 35) of Section 3 of the code is devoted purely to measures to limit false alarms. Clause 35 contains no less than 30 specific recommendations for consideration by the relevant parties. The measures advocated are divided into eight groups, namely:

- Siting and selection of manual call points.
- Selection and siting of automatic fire detectors.
- Selection of system type.
- Protection against electromagnetic interference.
- Performance monitoring of newly commissioned systems.
- Filtering measures.
- System management.
- Regular servicing and maintenance.

The 30 specific recommendations are not intended to constitute definitive 'rules'. On the other hand, they cannot be ignored if the various stages in system evolution and use are to comply with the code. Thus, the code recommends that the 30 recommendations in question be taken into account by any parties responsible for specification, design, commissioning or verification

limitation of false and unwanted alarms

of a fire alarm system, and by maintenance organizations at the time of consideration of false alarm problems.

8.6.1 Siting and Selection of Manual Call Points

The recommendations for suitable siting and selection of manual call points relate primarily to avoidance of exposure of call points to accidental damage and malicious operation. Principally, this involves care in siting within certain high risk areas. As examples of areas in which there might be exposure to accidental damage, the code quotes areas in which trolleys or forklift trucks are used, and sports halls and gymnasias, in which ball sports are played. As examples of areas in which there is significant potential for malicious operation of call points, the code suggests shopping malls, some public houses, cinemas, theatres, nightclubs, schools, universities, certain public entertainment premises and public car parks.

In the case of shopping malls, the code recommends that manual call points should not be located within the malls themselves. In certain of the public premises described above, the code recommends that, subject to the agreement of all relevant enforcing authorities, it might be appropriate either

to omit manual call points from areas accessible to the public or to site them so that they are accessible only to authorized persons, provided there is adequate surveillance of the entire premises by people or CCTV and that manual call points are provided at suitably staffed locations. For example, it is not uncommon, in the case of certain public houses, to locate manual call points behind the bar.

Where mechanical damage is likely, the code refers to the use of guards. Hinged covers are also advocated for consideration as a form of guard and as a measure to limit malicious false alarms in the case of schools, universities, certain public entertainment premises and public car parks. Again, however, this would require the agreement of all relevant enforcing authorities, as the manual call points would not then conform to the requirements of BS EN 54-11 for Type A manual call points, and agreement of a variation from the normal recommendations of the code would be necessary. In the case of public car parks, the code suggests that consideration might also be given to the use of a suitable emergency voice communication system (e.g. emergency telephones or an intercom system) in lieu of manual call points. This would also require approval of enfor-

limitation of false and unwanted alarms

cing authorities, and it would be appropriate for such a system to comply with BS 5839-9.

Ingress of moisture into a manual call point can cause malperformance of the device. In the case of an addressable system, such an event can cause various random fault and fire signals. Accordingly, the code recommends that, in areas in which manual call points are exposed to moisture, suitably moisture-resistant devices should be used. In practice, the performance would be specified by means of a relevant IP rating (e.g. IP X5). As examples of such areas, the code gives external locations, wet areas of industrial buildings, food-processing areas that are subject to periodic washing down and certain kitchens. A practical example would be the case of breweries, where there are often 'wet' areas. In many kitchens, ingress of water is not a recognized problem, but it is not unknown for condensation to create problems for manual call points, and water could, of course, occur in wash-up areas.

8.6.2 Selection and Siting of Automatic Fire Detectors

In the case of automatic fire detectors, the code refers to 'selection and siting', whereas, in the case of manual call points, the

term used was 'siting and selection'. This reversal of words is not accidental. In the case of manual call points, the code regards the siting of the devices as the critical factor, whereas, in the case of automatic fire detectors, greater emphasis is placed on selection.

However, as discussed above, if it is known that the provision of automatic fire detectors is likely to result in a high level of unwanted alarms, the first question that the designer should ask is whether, in fact, the provision of automatic fire detection is actually necessary. In this context, the 'necessity' will depend on the objectives of the fire alarm system, which should be clearly understood by the designer.

Over the last two decades, because of its greater sensitivity, smoke detection has become something of the 'default' form of fire detection, with heat detection specified only if it is obvious that smoke detectors would result in false alarms. However, the code recommends that, for systems complying with the 2002 version, consideration should be given to the use of heat detection, before smoke detection is specified. Thus, the code recommends that it should be confirmed that the use of heat detectors would not satisfy both the objectives of the fire

limitation of false and unwanted alarms

alarm system and the recommendations of the code.

Unless there is an equipment fault, if heat detectors do generate false alarms, it is likely that the reason is either a high ambient temperature or rapidly fluctuating ambient temperatures. To avoid such false alarms, the code provides guidance on the 'headroom' that should exist between ambient temperatures and the temperature of operation of heat detectors. Rate of rise heat detectors should not be installed in locations in which rapid fluctuations in temperature may occur. Examples given in the code comprise kitchens, boiler rooms, loading bays with large doors to open air and lantern-lights.

A common perplexity to face designers is the type of smoke detector that should be specified (i.e. optical or ionization chamber). Clause 35 of the code provides guidance on considerations in respect of false alarms that should be taken into account in selecting point and optical beam smoke detectors.

Most aspirating smoke detection systems are considerably more sensitive than normal point-type smoke detectors. Indeed, the high sensitivity of these devices is the most common reason for them to be specified (e.g. in critical electronic equipment rooms). However, the code advocates that special consideration is given to ensure that the high sensitivity does not result in unwanted alarms. In this connection, aspirating smoke detection is sometimes specified in circumstances in which its advantage is not so much its high sensitivity, but the opportunity to install relatively 'invisible' fire detection that will not affect the ambience of, say, a stately home.

In these circumstances, high sensitivity is not required in order to satisfy the objective of the system. Accordingly, in such cases, the code advocates the use of aspirating systems that can be arranged to provide sensitivity equivalent to that of point smoke detectors conforming to BS EN 54-7, since, were it not for the visual impact of point detectors, they might well have satisfied the fire safety objective quite adequately. This is possible with the VES-DA aspirating detection system.

limitation of false and unwanted alarms

Carbon monoxide fire detectors are sometimes specified in situations where false alarms might arise from smoke detectors and to provide much more sensitive detection than could be afforded by heat detectors. However, it is important to take account of circumstances that might result in unwanted alarms from CO detectors. Normally, such circumstances will be those in which carbon monoxide is generated, such as badly ventilated kitchens, areas in which vehicle or other exhaust fumes occur and some laboratories.

Similarly, it is a simple truism that infra-red and ultraviolet flame detectors should not be located in areas in which sources of infra-red or ultraviolet radiation create the potential for unwanted alarms. The mere presence of infra-red radiation itself, however, does not necessarily generate potential for unwanted alarms, as various techniques can be adopted to prevent this (e.g. generation of fire alarm signals from infra-red flame detectors only if the infra-red radiation sensed has the characteristic flicker frequency of a diffusion flame). Accordingly, the code recommends that the guidance of the manufacturer of the detector, in respect of sensitivity of detectors to other non-fire sources of radiation, should be taken into account.

8.6.3 Selection of System Type

Digital fire detection systems are regarded as less prone to unwanted alarms than conventional fire detection systems. Even the simple pre-alarm warning incorporated within digital systems provides an opportunity for the user to investigate a situation that, had it been permitted to continue, would have resulted in a false alarm.

The code recommends that, unless there are overriding considerations, systems that incorporate a high number of smoke detectors should be of the digital type. It is for the designer to determine what constitutes a high number of smoke detectors, but a relatively tentative suggestion within the code is that a high number might be regarded as more than 100 detectors.

Arguably, the future for reduction of false alarms lies in the use of multi-sensor detection systems that incorporate measures to filter out false alarms from environmental influences that principally affect only one of the sensors incorporated within each detector. It should, however, be noted that not all multi-sensor detection systems incorporate such measures; some multi-sensor detectors use the multi-sensor feature primarily to offer good sensitivity to a broader spectrum of fires.

limitation of false and unwanted alarms

However, the code recommends that, in systems that incorporate a very high number of automatic fire detectors (other than heat detectors), the use of systems that include multi-sensor fire detectors and incorporation of suitable measures to minimize the potential for unwanted alarms should be considered at the design stage. Again, only tentative advice on what constitutes a 'very high number' of detectors is offered in the code; more than 1,000 detectors is suggested as constituting a very high number. However, looking to the future, the code suggests that, as standards for multi-sensor fire detection systems are produced, and more proprietary systems become available, more definitive advice might be given and the definition of 'very high number' might be reduced, if evidence of significant improvements in unwanted alarm immunity can be established for these systems.

8.6.4 Protection Against Electromagnetic Interference

Modern fire alarm systems are less susceptible to electromagnetic interference than the systems of 10 - 20 years ago. However, the code recognizes electromagnetic interference as a potential cause of unwanted alarms. Clause 28 of the code provides

some practical guidance on avoiding false alarms as a result of electromagnetic interference. In addition, it is recommended that the designer should take into account the likely sources of electromagnetic radiation in the building. These include mobile telephones, two-way radios, mobile telephone base stations (which are often found now within buildings) and other high power transmitters.

In some cases, very high electromagnetic field strengths might occur. Examples are radio transmitter sites, airport terminals and radar stations. In these cases, the code recommends that guidance should be sought from the system manufacturer, so that special measures, such as the provision of filters on external circuits, can be incorporated to reduce the potential for unwanted alarms. In the case of an existing building, where unusually high field strengths occur, the code recommends that information be provided to the system manufacturer regarding the field strengths that exist. This, effectively, implies that actual measurements should be carried out in these cases.

limitation of false and unwanted alarms

8.6.5 Performance Monitoring of Newly Commissioned Systems

Sometimes, false alarms occur in the early life of a system. This can arise from 'infant mortality' of components, poor siting of detectors that was not identified before handover, and environmental influences that were not appreciated prior to handover. These early problems are sometimes attributed to 'settling in' of the system, but are really more accurately the result of previously undetected problems. In order to prevent these problems causing actual false alarms, the code recommends that, in the case of systems incorporating more than 50 automatic fire detectors, a 'soak period' should follow commissioning. A soak period is defined in the code as a period after a fire alarm system has been commissioned, but prior to handover, during which the system's performance in relation to false alarms and faults is monitored. Thus, other than in the case of small systems, handover, as envisaged in the code, is not complete until completion of the soak period.

The code recommends that the duration of the soak period should be at least one week, but the actual period should be defined by the designer and incorporated within any tender specification. Within the model design certificate, the designer

is required to indicate whether no soak test is required, based on the number of automatic fire detectors, or to define the period for the soak test. Where a soak test is required, since it will immediately follow commissioning, the model certificate of commissioning also contains a space in which the period of any required soak test should be recorded.

Obviously, until successful completion of the soak test, the system should not be regarded as the means of giving warning of fire in the building. Thus, during this period, each manual call point should bear an indication that it is not to be used. In practice, this means that, in the programme for a new building project, allowance would have to be made for the soak period before occupation of a building. Where an existing fire alarm system is being replaced by a new system, strip out of the old system clearly should not begin until the completion of the new system's soak test. Practical difficulties may, however, arise in complying with the code if the new system uses the wiring of the old system.

The code defines the criteria for successful completion of the soak test, namely that:

- 1) During the soak period, no false alarm occurred; or

limitation of false and unwanted alarms

- Investigation of all false alarms that occurred, by the supplier of the system, has identified the cause of every false alarm and enabled any relevant measures to be taken to minimize potential for similar false alarms to occur in the future.

8.6.6 Filtering Measures

Even if all the above recommendations for limitation of false alarms are dutifully followed, the code acknowledges that the rate of false alarms (e.g. expressed as one false alarm per n detectors per annum), or the sheer number of false alarms, might be unacceptable. The code envisages that the unacceptable extent of false and unwanted alarms might actually be anticipated at the design stage or that it might only come to light after operational experience. For example, if there is a large number of automatic fire detectors, the number of false alarms that might be anticipated by the designer, even at the initial design stage, might be regarded by the user as unacceptable, even though the actual rate is well within the definition of acceptability given in the code. Under these circumstances, the code suggests that 'filtering' measures might be appropriate, particularly in installations with a very large number of automatic fire detectors, which the code suggests might be, for example, more than 1,000 detec-

tors. Two forms of 'filtering' are described in the code.

The first (and, in practice, the less common) form of filtering is the use of a 'time related system'. In such a system the form of protection varies on a time related basis. For example, smoke detectors may be disabled automatically during normal working hours, so that, in effect, the system is Category M during working hours and Category P outside normal working hours. This technique could not, of course, be applied if the function of the automatic fire detection were life safety, as it would, obviously, be needed when people were present.

Other forms of time related system include those in which detector sensitivity is reduced at certain times, such as during working hours, and multi-sensor systems in which one of the sensors is disabled (or reduced in sensitivity) at certain times. In the latter case, if, say, smoke sensors are disabled during normal working hours, but protection at these times by heat detectors is still required, the detector spacing should follow that recommended for heat detectors, rather than that recommended for smoke detectors.

In all of the above examples, the actual causes of false and unwanted alarms are

limitation of false and unwanted alarms

not eliminated or reduced; it is merely that the false alarms are 'filtered out' by preventing response to the causes of false and unwanted alarms at certain times of day. It goes without saying, however, that the modified form of response, and associated reduction in the level of protection, needs to be understood by, and be acceptable to, the relevant interested parties.

The second form of filtering involves the use of a 'staff alarm'. The code defines a staff alarm as a restricted alarm, following the operation of a manual call point or automatic fire detector, given to certain staff in the premises to permit investigation prior to evacuation.

Secondly, although the definition refers to a delay in evacuation, quite often the summoning of the fire service (whether via the public emergency call system or via an alarm receiving centre) is also delayed, so that summoning of the fire service does not occur unless and until an evacuation is initiated. It might actually be preferable to delay the summoning of the fire service until the expiry of the investigation period if the fire brigade attendance time is less than the investigation period; otherwise, in these circumstances, at the time of arrival of the fire service, investigation is still underway, the premises are still fully occupied and no audible fire alarm signal is sounding. The

arrival of the fire service under these circumstances may not only be unwarranted, but it may cause confusion.

Staff alarms are becoming quite common in large, complex buildings that are protected by a high number of automatic fire detectors, particularly smoke detectors. The use of a staff alarm does, however, necessitate a good standard of management. There must be sufficient staff to investigate, and manage the situation thereafter, at all times that the staff alarm arrangement applies, and there must never be any suggestion that staff might simply endeavour to cancel the alarm during the investigate period and then investigate at leisure.

In practice, the staff alarm normally applies at all times, but there is no reason why, in certain premises, it should not only apply at certain times of the day, such as normal working hours, in which case the system is also a time-related system.

Although filtering should, arguably, always be considered at the design stage in systems with very large numbers of smoke detectors, filtering measures should not be regarded as an 'easy' option to mask shortcomings in system design that could be improved by other means. The code recommends that filtering measures should

limitation of false and unwanted alarms

only be adopted under the following circumstances:

- 1) After consultation and agreement with all relevant enforcing authorities; and
- 2) In the case of Category P systems in which it is proposed to incorporate an investigation period prior to the summoning of the fire service, after consultation with the insurers; and
- 3) Where it is considered that either the rate of false and unwanted alarms (expressed as number of false alarms per 100 detectors per annum) or the actual number of false alarms, cannot be limited to a level acceptable to the user and the fire service by other means; and
- 4) Where it is considered that the incorporation of filtering measures does not negate the objectives of the system in terms of protection of life, property, business continuity or the environment.

Point 4) above cannot be stressed strongly enough. The natural concern on the part of users to avoid the effects of false

and unwanted alarms sometimes blinds them to the need for a strategy that will be robust in ensuring the safety of people in the event of an actual fire. A good false alarm strategy is not necessarily a good fire safety strategy!

Even so, properly designed filtering measures do incorporate safeguards to ensure that potential delays in implementing fire procedures in the event of fire are minimized. For example, the code recommends that filtering should not be applied to signals initiated by manual call points. Thus, during the investigation period, if anyone in the building, including those investigating the alarm signal, discover a fire, the alarm can be raised quickly by use of any nearby manual call point. (A staff alarm is sometimes accepted as the response to operation of a manual call point in public entertainment premises, but this is not primarily for the purpose of filtering out false alarms, but to enable predetermined staff actions to be put in place to assist the public with evacuation.) Staff alarms should only be used where staff, including any night staff, are sufficient in number and fully trained in the action they are to take in the event of fire.

A further common safeguard incorporated within staff alarm arrangements

limitation of false and unwanted alarms

is coincidence detection. When this arrangement applies, although only a staff alarm results from the operation of a single automatic fire detector, operation of any two detectors will result in a full fire alarm condition. The value of coincidence detection is acknowledged in the code, albeit that it is not specifically recommended that it should always be incorporated within a staff alarm arrangement.

If the fire service is not summoned immediately at the start of any investigation period associated with a staff alarm, it is essential that they are summoned immediately on expiry of this period. In residential care premises summoning of the fire service is paramount and should be immediate upon the staff alarm operating, even when there may be a delay in sounding the general alarm. A note in the code acknowledges that reliability and compliance with this recommendation can be aided by the use of facilities to transmit signals automatically to an alarm receiving centre on expiry of the investigation period. Some fire authorities actually make this a requirement for acceptance of a staff alarm arrangement.

Filtering of alarm signals at the alarm receiving centre, in the form of a telephone call to the protected premises to verify that the alarm is genuine, is

commonly used in respect of intruder alarm signals. It is uncommon for this to apply to fire alarm signals, but such an arrangement is not precluded. Care would, however, be necessary to ensure that filtering did not occur at the protected premises and also, subsequently, at the alarm receiving centre, as this would be likely to cause an unacceptable delay in transmission of signals to the fire service.

Automatic sprinkler systems are not prone to false alarms. False alarms as a result of actual water discharge from sprinkler heads is extremely rare, and, when it does occur, it is normally the result of significant events, such as mechanical damage (e.g. by forklift trucks), corrosion of heads in aggressive environments, freezing of unheated pipework, etc. However, unwanted alarms do sometimes occur in systems that are supplied from water mains, as opposed to the now more common form of supply, namely a water storage tank and pumps. In systems supplied directly from towns mains, the pressure in the main may rise at night as a result of low demand. This increase in pressure can lift the clack of the alarm valve, permitting water to flow through the pipework that serves the hydraulic alarm gong. The normal means of providing a signal from a sprinkler system to a fire alarm system comprises a pressure switch within this pipework.

limitation of false and unwanted alarms

Accordingly, a false alarm can arise under these circumstances.

Where a signal from an automatic sprinkler system that is supplied from water mains is used as an input to the fire alarm system, there should be liaison with the organization responsible for installing or maintaining the sprinkler system to minimize potential for unwanted alarms as a result of water pressure surges. In practice, this is usually achieved by a hydraulic or electronic time delay facility, and consideration of these measures is recommended by the code under such circumstances. An electronic time delay, which is probably more common, is usually achieved by use of a pressure switch that incorporates a variable time delay (for which the pressure sensed must exist) within the switch; a similar arrangement could be applied at the fire alarm control equipment, but it is normally at the sprinkler installation that the matter is addressed.

8.6.7 System Management

The code also makes recommendations for ongoing management of the fire alarm system by the user. As the user is unlikely to possess, or read, the code, it is important that the designer and supplier of the system inform the user regarding these

recommendations. The recommendations in question are intended to ensure that, for example, contractors are properly appraised of the measures necessary to minimize false and unwanted alarms during building work; various measures that are appropriate during such work are recommended in the code. The code also highlights the importance of ensuring that staff in the building are aware of the presence of automatic fire detection, so that they can avoid actions that could cause false and unwanted alarms. Staff also need to be informed when routine testing or maintenance work might cause the occurrence of a fire alarm signal. More generally, the building, and any plant in the building, should be adequately maintained to ensure that leaking roofs, steam leaks, etc do not cause unwanted alarms.

When false and unwanted alarms do occur, the code recommends that suitable action should be taken by the user. Relevant actions are discussed in the code, but it should be stressed that, at the very least, this should comprise recording of the false and unwanted alarm and all relevant associated information in the system log book.

limitation of false and unwanted alarms

8.6.8 Servicing and Maintenance

In order to limit false and unwanted alarms, servicing and maintenance of the system should be carried out by a competent organization. Generally, a contract for periodic servicing and emergency call out should be set up before the system becomes operational.

8.6.9 New non compliances

It is accepted that it is not the responsibility of those carrying out the maintenance of the system to identify non compliances with the design standard; although if any are discovered they should be reported to the relevant person/system designer.

means of giving warning to occupants

9. Means of Giving Warning to Occupants

Category M and Category L systems must be capable of giving an audible warning of fire throughout the building, as the principal purpose of these systems is to warn occupants in the event of fire, so that they can evacuate the building. In theory, a Category P system does not have to provide an audible warning throughout the building, since its purpose is purely to ensure that fire-fighting action is taken, and this might not necessitate an audible warning to all occupants of the building. In practice, a Category P system is usually combined with a Category M system, in which case the recommendations for audible alarm signals applicable to a Category M system will take precedence and be more onerous.

Strictly, nevertheless, the code only recommends that, in the case of a Category P system, the recommendations regarding audible alarm signals need only be applied in areas where such audible alarm signals are required. Thus, for example, in a building with an existing Category M system, a separate, supplementary Category P system could meet the recommendations of the code without a facility to provide an audible

warning throughout the building when detectors operate.

When designing fire alarm systems, careful consideration must be given to the positioning of sounders. The audibility of sounders can differ quite significantly depending upon where they are located. It should be ensured that sufficient, suitably located sounders are provided to ensure adequate audibility in all relevant areas of the premises.

9.1 Sound Pressure Level

The code recommends that, generally, the minimum sound pressure level produced by sounders in all accessible areas of the building should be at least 65dB(A) or 5dB above any other noise likely to persist for longer than 30 seconds, whichever is the greater [16.2.1]. There are, however, a number of relaxations from this recommendation, and these are set out below:

- The minimum figure of 65dB(A) is reduced to 60dB(A) in:
 - stairways;
 - enclosures of no more than approximately 60m² in area (e.g. cellular offices);

means of giving warning to occupants

- specific points of limited extent. (This means that, although the designer should endeavour to achieve the minimum sound pressure level of 65dB(A), the system is still acceptable if, at one or more points of limited extent, the sound pressure level measured is between 60dB(A) and 65dB(A)).
- No minimum sound pressure level applies to habitable enclosures of less than 1m² in area.
- No measurement of sound pressure level need be carried out within 500mm of any walls or partitions, other than within rooms in which the fire alarm system is intended to rouse people from sleep.
- If any area is specifically designated as that from which the fire service will be summoned in the event of fire (e.g. a telephone operator's room), the code does not specify a minimum sound pressure level, but it needs to be ensured that the fire alarm signal is not so loud as to interfere with telephone speech. If, however, the sound pressure level of background noise in this area is greater than 60dB(A), the sound pressure level of the fire alarm

signal should be 5dB above the sound pressure level of the back ground noise. (Care should also be taken to ensure that sounder frequencies can not confuse tone dialling systems, leading to failure of the emergency call).

If the fire alarm system is intended to rouse people from sleep, the code recommends that the sound pressure level at the bed-head, within rooms in which people sleep, should be at least 75dB(A). In practice, this will necessitate the provision of a fire alarm sounder within each room in question.

means of giving warning to occupants

Table 9 below shows the typical sound pressure level produced by various types of sounder at different distances. It should be noted that, in the case of electronic sounders, the figures quoted relate to sound pressure level measured along the axis of the sounder. Electronic sounders are directional in output, and a lower sound pressure level will be achieved at points off the axis of the sounder. In such cases, the manufacturer's data sheet should be consulted.

SOUNDER TYPE	SOUNDER PRESSURE LEVEL dB (A)				
	@ 1 Metre	@ 2 Metre	@ 4 Metre	@ 8 Metre	@ 12 Metre
6" Bell	91	85	79	73	67
8" Bell	95	89	83	77	71
Small electronic Sounder	103	97	91	85	79
Large electronic Sounder	113	107	101	95	89
Bedhead Sounder	96	90	84	78	72
Base Sounder	85	79	73	67	-

table 9. Typical sound pressure level at various distances

means of giving warning to occupants

9.2 Discrimination and Frequency

Two important factors relating to any sounders used in fire alarm systems are Discrimination and Frequency.

Discrimination The type, number and location of fire alarm sounders should be such that the alarm sound is distinct from all the background noise. The note of the fire alarm sounders should also be distinct from any other alarm sounds that are likely to be heard.

All fire alarm sounders within the building should have similar sound characteristics, unless particular conditions, such as an area of high background noise make this impracticable. In this case, other types of fire alarm device may also be used, such as flashing coloured beacons [17.2].

Frequency Young persons are most sensitive to sounds at frequencies between 500 Hz and 8,000Hz. Age and hearing damage reduce the sensitivity of the ear, particularly to frequencies above 2,000 Hz. Partitions, dividing walls and doors attenuate sound; in general, the higher the frequency of the sound, the greater the attenuation.

Because of this, fire alarm sounders should therefore ideally lie in the range 500 Hz to 1,000 Hz [16.2.1b)]. However, if the frequency of background noise is within this frequency range, and the level of background noise is such that the sound of fire alarm sounders producing 500 - 1,000Hz could be 'masked' by the background noise, the use of fire alarm sounder frequencies outside this range is acceptable.

9.3 Sound Continuity

The code states that the sound of the fire alarm should be continuous, although the frequency and amplitude may vary (for example, as in a warbling note) to indicate the need for evacuation or other urgent response.

9.4 Audible Alarms in Noisy Areas

In areas of a building where there are noisy machines, the power requirements of high powered sounders needed to comply with the recommendations of the code (see 9.1 above) may place excessively high demands on the power capacity of the fire alarm system. In such cases, the primary sounders may be reinforced by secondary sounders operated directly from the mains

means of giving warning to occupants

supply and without standby supplies, provided the following conditions apply [16.2.1e]:

1. The mains powered sounders are operated from the same final circuit(s) as the noisy machines, so that failure of the supply to these secondary sounders also results in the silencing of the noisy machines.
2. When the machine noise ceases and the secondary sounders are out of service, the primary sounders meet the sound levels recommended in the code (see 9.1 above).

In premises designed for public entertainment, retail and similar premises, in which the sound pressure level of music is likely to be greater than 80dB(A), the music should be muted automatically when a fire alarm signal is given. (If the sound pressure level of the music is likely to be between 60dB(A) and 80dB(A), the sound pressure level of the fire alarm signal should, of course, still be 5dB above the level of the music.

9.5 Alarm Zones

In many buildings, the fire alarm system is so arranged that, when any manual call point or fire detector operates, fire alarm sounders operate throughout the building, so that the entire building is evacuated simultaneously.

In larger, more complex buildings, it may be the case that, in the event of an alarm signal in one area, occupants in other areas are given only an 'alert' signal to warn them of the possible need for evacuation at a later stage. This occurs in buildings with phased evacuation, which is often used in tall buildings; in such cases, usually only two or more floors are evacuated at any one time.

In these cases, the premises are divided into 'alarm zones'. An evacuation signal can then be given in one alarm zone without giving an evacuation signal in other alarm zones; normally an 'alert' signal is given in these other alarm zones. Such an arrangement should only be used with the agreement of the building control and fire authorities. Care needs to be taken that overlap of signals between alarm zones does not result in confusion of occupants. It should be ensured that no occupant can clearly hear both an 'evacuate' signal and an 'alert' signal.

means of giving warning to occupants

Where there is more than one alarm zone in the building, a separate evacuation control should be provided for each part of the premises in which an evacuation signal needs to be given simultaneously. However, in buildings with phased evacuation, sometimes there is inadequate staircase capacity to evacuate the entire building simultaneously. In the latter case, no single control that will result in an evacuation signal throughout all alarm zones simultaneously should be provided; such a control should, however, be provided in all other buildings with two or more alarm zones.

In a building with two or more separate alarm zones, 'alert' signals may stop automatically after 30 seconds, provided that, at periods not exceeding three minutes, the signal is restored for a period of at least ten seconds until it is manually silenced. While provision of this automatic silencing is not mandatory for compliance with BS 5839-1, the arrangement prevents unnecessary disruption of occupants until they are required to evacuate.

9.6 External Fire Alarm Devices

There is no need to provide external fire alarm sounders in order to comply with BS 5839-1. However, if the fire service consider that there would be a need for,

or benefit from, external alarm devices to direct them to the appropriate building or appropriate entrance to a building, such sounders may be provided. However, the code recommends that any such external fire alarm sounders in Category L and Category P systems should silence automatically after 30 minutes, unless the premises are continuously occupied, so enabling manual silencing by occupants at any time.

External indication may, instead, be given by a visual alarm device, such as a flashing beacon. In this case, the visual device can continue until appropriate manual action is taken (e.g. silencing sounders and/or resetting the system (para 9.8 refers)).

9.7 Voice Alarm Systems and Voice Sounders

Instead of using fire alarm sounders, audible alarms may comprise voice messages generated by a voice alarm system. A voice alarm system is a specially designed sound distribution system (i.e. public address system), which, in the event of fire, broadcasts an alarm warning tone followed by a voice message. Voice alarm systems are commonly used instead of conventional fire alarm sounders in premises occupied by a large number of mem-

means of giving warning to occupants

bers of the public (e.g. shopping centre, transport terminal, large places of public entertainment, etc) and in buildings with phased evacuation. Voice alarm systems should comply with BS 5839-8.

In buildings in which it is not considered that a full voice alarm system is necessary, voice sounders can be used as an enhancement over conventional fire alarm sounders. Voice sounders are fire alarm sounders, connected to conventional fire alarm circuits, that generate and broadcast digitally recorded speech messages. Whereas, in a voice alarm system, there is normally a facility to override pre-recorded messages and transmit 'live' speech, this is not possible in a system that uses voice sounders. Guidance on the use of voice sounders is given in Annex E of BS 5839-8.

9.8 Fire Alarm Warnings for Deaf People

There is a need to warn deaf people in the event of fire, in which case additional facilities shall be provided. Where deaf people sleep in the building, vibrating devices, wired into fire alarm device circuits, can be placed under pillows or mattresses. Where deaf people have a need to move around a building, vibrating pagers can be given to each deaf person.

Visual alarm devices, complying with EN54-23, should be installed in places where audible devices alone would be ineffective, or where they are simply undesirable. Visual alarm devices should also be used in order to provide warning to hearing impaired personnel. BS5839-1 (17) refers to the Loss Prevention Code of Practice, CoP 0001 in respect of the design and installation of systems incorporating such devices.

Systems using vibrating pagers must be specially designed to satisfy the recommendations of BS 5839-1. This includes the provision of monitoring facilities, standby power supplies, etc, as recommended by BS 5839-1.

control and indicating equipment

10. Control and Indicating Equipment

The control and indicating equipment used in all fire detection and alarm systems should comply with BS EN 54-2. Confidence of compliance can be obtained by the use of equipment that is approved by the Loss Prevention Certification Board. Vds or other European accredited EN54 product test house.

Although we describe the features and operation of different types of fire detection and alarm systems in section 4, there are also other factors which should also be considered when designing a system, namely Siting of Control and Indicating Equipment, Location of Origin of the Alarm and Security of Control Equipment. Each of these topics is described below.

10.1 Siting of Control and Indicating Equipment

The siting of the control and indicating equipment should satisfy a number of recommendations:

1. Since the control equipment is essential for the operation of the system, it should be placed in an area of low fire hazard [23.2.1e)]. In a complex building with multiple entrances, it may be necessary to provide repeat indicator panel(s) at the building entry point(s) to be used by the fire brigade.
2. Indicating equipment, in conjunction with suitable manual controls should be sited at an appropriate location for both staff and fire-fighters responding to a fire signal. This should normally be an area on the ground floor close to the entrance of the building likely to be used by the fire service, or a suitably sited, continuously manned control room.
3. The ambient light level in the vicinity of all control and indicating equipment should be such that individual indications can be clearly seen, controls easily operated and any instructions or legends easily read.
4. In Category L and Category P systems, the area in which the equipment is sited should be protected by automatic fire detection. However, this recommendation does not apply if:
 - (I) The fire hazard level in the area in which the equipment is sited is negligible and there is an adequate degree of fire separation between

control and indicating equipment

this area and any area in which the fire hazard is not negligible; or

(II) The area in which the equipment is sited is continuously manned in the case of Category P systems, or continuously manned when the building is occupied by any person in the case of Category L systems.

5. Noise or other sound levels in the vicinity of the control equipment should not dilute the audible alarm given by the control equipment [23.2.1d].
6. In multi-occupancy buildings with communal areas, control and indicating equipment should be sited within a communal area. Otherwise, it should be sited in an area to which access is possible at all times when the building is generally occupied.

10.2 Location of Origin of the Fire

Although addressable systems can precisely locate the position of the fire, all fire detection and alarm systems (whether conventional or addressable) should provide zonal indication, in at least one prominent location (e.g. a matrix of LEDs or illuminated mimic diagram) to show the detection

zone(s) from which there are alarm signals. This provides the fire brigade with a simple overview of all detection zone(s) in which fire has been detected, without the need to scroll through a display.

If the zone indicators simply provide an indication of detection zone number, there will be a need for a plan of the building, adjacent to the indicating equipment, to show diagrammatically the locations of all detection zones.

However, if the zone indicators take the form of an illuminated mimic (an example of which is shown in Figure 25), this combines the function of zonal indication and geographic representation of the detection zone(s) from which alarm signals are being given.

10.3 Security of Control Equipment

The code recommends that the operation of certain controls be limited to authorised personnel only. Where the restriction is not provided on the control equipment, for example by means of a key switch, the code allows for security of the equipment to be provided by restricting access to it.

section one | guide to design, installation, commissioning and maintenance of fire systems in non domestic premises

control and indicating equipment

10.4 Networked Control Panels

In a large building, it is possible to network a number of control panels together, to form a 'networked system'. Generally, the network cables may need to be fire resisting and monitored, as they may form part of the critical signal path.

power supplies

11. Power Supplies

Virtually all systems will be powered from the public mains supply, with a secondary standby supply being provided by rechargeable batteries (sometimes in conjunction with a standby generator). If the standby batteries are supplemented by an automatically started generator, it is permissible to reduce the standby battery capacity of Category M and L systems [25.4e].

Both the primary mains supply and the secondary standby supply must be able to provide the maximum load independently of each other. The alarm load of the fire alarm system is the maximum load which the power supply must provide under fire conditions. This includes power drawn during simultaneous operation of the control and indicating equipment, all sounders, all detectors, all manual call points and transmission of signals to an alarm receiving centre.

11.1 Mains Supply

Connection of all systems to the public mains supply should be in accordance with the recommendations outlined in BS 7671 (Requirements for Electrical Installations – IEE Wiring Regulations, Seventeenth Edition). The mains supply for the

system should be connected via an isolating switch–fuse or circuit breaker used solely for the purpose of the fire detection and alarm equipment. Any switch (other than the main isolator for the building) that disconnects the mains supply to the fire alarm system should be clearly labelled ‘FIRE ALARM: DO NOT SWITCH OFF’. Any protective device (such as a fuse) that serves only the fire alarm circuit should be labelled ‘FIRE ALARM’.

The supply to the fire alarm system should be supplied from the load (‘dead’) side of the main isolating device for the building. Since this isolates all supplies in the building, it does not need to be labelled with a warning that it isolates the supply to the fire alarm system.

The circuits supplying the fire alarm system should not be protected by residual current devices, unless this is necessary to comply with BS 7671. When a residual current device is necessary for electrical safety, a fault on any other circuit or equipment in the building should not be capable of resulting in isolation of the supply to the fire alarm system; the RCD for the fire alarm system should be independent.

power supplies

To facilitate local isolation during maintenance, a double pole switch should be provided in the vicinity of the control and indicating equipment (and any other mains supply equipment forming part of the fire alarm system) so that maintenance technicians can isolate the mains supply to the fire alarm system locally to the equipment that the mains supply serves. The switch should be lockable to prevent unauthorised operation.

The presence of the normal or the standby supply should be indicated by a green indicator at the main control and indicating equipment, to show that power is being supplied to the system (whether from the mains supply or the standby supply).

11.2 Standby Supply

The provision of a standby supply is a requirement of the Health and Safety (Safety Signs and Signals) regulations.

The standby supply should be provided by secondary batteries with an automatic charger. The batteries should have an expected life of at least four years; the code specifically disallows the use of car-starting type batteries. In order that the full life of the batteries is achieved, it is important to ensure that the characteristics of the

charger match those of the batteries being used. The charger should be capable of charging fully discharged batteries in 24 hours.

In the event of a mains supply failure, the capacity of the standby supply must be likely to provide protection until the normal mains supply has been restored. The minimum requirements for the different system types and conditions are described in the following subsections.

11.2.1 Life Protection (Category M and L Systems)

The capacity of the standby batteries should be sufficient to operate the system for 24 hours normal operation, and also have sufficient capacity remaining at the end of this period to provide an evacuation signal throughout the building for 30 minutes.

If the building is provided with an automatically started standby generator that serves the fire alarm system (usually in conjunction with other essential supplies in the building), the capacity of the standby batteries should be sufficient to maintain the system in operation for at least six hours, after which sufficient capacity should remain to provide an 'evacuate' signal in all alarm zones for at least 30 minutes.

power supplies

11.2.2 Property Protection (Category P Systems)

The capacity of the standby batteries required for property protection systems is dependent on whether or not a mains supply failure will be immediately recognised within the building or via a remote link to an alarm receiving centre.

The capacity of the standby batteries required for property protection systems is identical to that required for Category M and Category L systems (i.e. sufficient to operate the system for 24 hours and provide an evacuation signal for 30 minutes thereafter) PROVIDED:

1. The building is continuously manned, so that staff in the building would be aware of a power supply fault indication on the system within no more than six hours of its occurrence; or
2. The building is inspected outside normal working hours such that staff would be aware of a power supply fault indication within no more than six hours of its occurrence; or
3. Power supply fault signals are transmitted automatically to an alarm

receiving centre, instructed to notify a keyholder immediately on receipt of a fault indication from the premises.

In all other circumstances, the battery capacity should be sufficient to maintain the system in operation for at least 24 hours longer than the maximum period for which the premises are likely to be unoccupied, or for 72 hours in total, whichever is less, after which sufficient capacity should remain to operate all fire alarm devices for at least 30 minutes. If the building is likely to be unoccupied for more than the duration of the standby battery capacity at any time, and there is a facility for transmission of fire signals to an alarm receiving centre (as there normally will be in a Category P system - see Section 13), power supply fault signals should also be automatically transmitted to the alarm receiving centre, for immediate notification of a key holder. It should be noted that, in the case of Category P systems, there is no relaxation in standby battery capacity if an automatically started standby generator is provided.

11.2.3 Calculation of Standby Battery Capacity

For systems designed in accordance with BS 5839-1, compliance with the code requires that the battery capacity of

section one | guide to design, installation, commissioning and maintenance of fire systems in non domestic premises

power supplies

valve regulated lead acid batteries should be calculated in accordance with the following formula:

The formula in question is:

$$C_{\text{MIN}} = 1.25 (T_1 I_1 + D I_2 / 2)$$

where:

C_{MIN} = minimum capacity of the battery when new at the 20 hour discharge rate and at 20°C (in ampere-hours).

T_1 = total battery standby period in hours.

I_1 = total battery standby load in amperes.

I_2 = total battery alarm load in amperes.

D = a de-rating factor.

1.25 is a factor to allow for battery ageing.

The de-rating factor is intended to take into account the fact that the effective capacity of a battery depends on the rate at which it is discharged. Battery capacity is normally quoted at the 20 hour discharge rate. Thus, a 20 amperes hour battery would be capable of providing one amp for 20 hours. However, it would not be capable of providing 20 amperes for one hour. The de-rating is needed in cases

in which the alarm current is sufficiently high to reduce the effective capacity below its nominal value.

Where $C_{\text{MIN}}/20$ will be equal to or greater than I_2 , it can be assumed that $D = 1$. When $C_{\text{MIN}}/20$ is less than I_2 , the value of D should either be based on the battery manufacturer's data or should be 1.75.

Example 1: Category M or Category L System

Consider premises that are unoccupied from 6.00 pm Friday until 9.00 am Monday. Assume the normal operating current of the system is 350mA and the maximum alarm load is 2.0A. The capacity of the standby batteries would be:

$$1.25(24 \times 0.35 + 1.75 \times 2 \div 2) = 12.7$$

The next highest available capacity size should be used.

If, however, the circuit serving the fire alarm system is served by an automatically started standby generator, the capacity can be reduced to:

$$1.25 (6 \times 0.35 + 1.75 \times 2 \div 2) = 4.8\text{Ah}$$

power supplies

Example 2: Category P System

As the premises are unoccupied for 63 hours, a battery having capacity to operate the system for 72 hours is required. Accordingly, the required battery capacity would be:

$$1.25 (72 \times 0.35 + 1.75 \times 2 \div 2) = 33.7\text{Ah.}$$

Again, the next highest available size should be used.

cabling considerations

12. Cabling Considerations

Correct operation of a fire alarm system depends on the interconnections between the control equipment, detectors, call points and sounders. Unless these interconnections operate correctly when required, the system will not fulfil its intended functions.

The components of most fire detection and alarm systems are connected by cables. For specialised applications where cabling cannot be used, fibre optics and/or radio links are used. Clause 27 of BS 5839-1 covers radio-linked systems. These systems are 'wireless', in that all communications between control equipment and devices (manual call points, detectors and sounders) is carried out using radio transmission. Where fibre optic cables are used they should provide at least the same integrity and reliability as cables recommended for the same purpose.

When selecting cables for a fire alarm system due consideration should be given to the following:

1. Resistance to fire
2. Current carrying capacity.
3. Voltage drop under maximum current conditions.
4. Insulation characteristics.
5. Mechanical robustness, resistance to corrosion and rodent attack, etc.
6. Screening (where applicable).
7. Suitability for carrying data (where applicable).

Although a wide variety of different cables could be used in various parts of a fire alarm system, many may be restricted in their suitability because of their varying abilities to resist both fire and mechanical damage. All cables used in fire detection and alarm systems (including those serving the mains supply to the system) must be fire resisting. The recommended cable types are described in the following subsection.

12.1 Recommended Cable Types

The type of cable, its routing and its physical and electrical protection characteristics should be specified for each particular installation. Wiring, in general, must comply with the latest issue of BS 7671 Requirements for Electrical Installations - IEE Wiring Regulations (currently Seventeen Edition). Wiring for specific systems should also conform to BS 5839-1 : section 26.

cabling considerations

Cables used throughout the system (including that used for the final circuit providing mains voltage to the system) should comprise only one of the following types of cable:

- 1) Mineral insulated copper sheathed cables. Conforming to BSEN 60702-1 and BSEN 60702-2
- 2) Proprietary fire resisting cables that conform to BS 7629 (these are sometimes described as 'soft skinned' fire resisting cables).
- 3) Armoured fire resisting cables conforming to BS 7846.
- 4) Cables rated at 300/500V (or greater) and that provide the same degree of safety to that afforded by cables complying with BS 7629.

BS 5839-1 divides fire resisting cables into two categories, described as standard fire resisting cables and enhanced fire resisting cables.

Cables used for the installation of fire alarm systems, including those for the electrical supply, should whatever their design properties, have been independently tested and approved to BS EN 50200 PH30/60 for standard fire resistance or PH 120 BS8434-2 for enhanced fire resistance. All

other approvals appropriate to that specific cable type would be in addition to the aforementioned tests.

12.2 Cable Suitability

For some applications, such as those listed below, the code recognizes that the level of fire resistance described as 'enhanced' is desirable:

- 1) in unsprinklered buildings (or parts of buildings) in which the fire strategy involves evacuation of occupants in four or more phases;
- 2) in unsprinklered buildings of greater than 30m in height;
- 3) in unsprinklered premises and sites in which a fire in one area could affect cables of critical signal paths associated with areas remote from the fire, in which it is envisaged people will remain in occupation during the course of the fire. Examples may be large hospitals with central control equipment and progressive horizontal evacuation arrangements, and certain large industrial sites;

cabling considerations

- 4) in any other buildings in which the designer, specifier or regulatory authority, on the basis of a fire risk assessment that takes fire engineering considerations into account, considers that the use of enhanced fire resisting cables is necessary.

It should be noted that, in the first three specific cases, sprinkler protection would obviate the need for use of cables of enhanced fire resistance. It is considered that, in a sprinklered building, the fire risk, the likelihood of fire development and the likely exposure of cables to fire make the use of cables of standard fire resistance acceptable. However, for the purpose of this recommendation, a building should be regarded as sprinklered only if an automatic sprinkler installation is provided throughout the building.

The reason for the use of enhanced fire resisting cables in unsprinklered buildings in which there is evacuation in four or more phases is simply that, in these situations, occupants will be expected to remain in the building for some time after fire is detected. It is therefore essential that the system is capable of reliably giving warning to occupants during the very last phase of the evacuation. It is also im-

portant that there is a high reliability and that indication from other automatic fire detectors of fire spread can be given at the control and indicating equipment.

In a large building with phased evacuation, a networked fire alarm system might be provided, with several control panels interconnected by a data network. In this case, individual, self-contained fire alarm systems might serve parts of the building that are evacuated in less than four phases, even though the entire building is evacuated in four or more phases. In these cases, cables of enhanced fire resistance need not be used for the systems themselves, but there may be a need to use cables of enhanced fire resistance for the network. However this may not be necessary if the network is configured in a loop, with diverse routing of incoming and outgoing circuits, and if the loop is designed in such a way that there will be no loss of communication to any sub-panel in the event of a single open or short circuit on the loop.

The recommendation for cables of enhanced fire resistance in unsprinklered buildings of greater than 30m in height simply reflects the greater risk associated with tall buildings. In those cases, phased evacuation is often used, and the recommendation relating to phased evacuation

cabling considerations

will already apply. It should also be noted that legislation normally requires new buildings of greater than 30m in height to be sprinklered, unless the buildings are of a residential or institutional nature (i.e. flats, hospitals, residential care premises, hotels, hostels, etc). It is, nevertheless, important that the recommendation for use of cables of enhanced fire resistance in unsprinklered buildings of greater than 30m in height be borne in mind when retrofitting fire alarm systems that might not have required sprinkler protection at the time of construction.

The third situation, in which cables of enhanced fire resistance are specified above, often occurs in hospitals.

In a hospital, the principle of progressive horizontal evacuation applies. This means that, in the first stages of a fire, patients are moved horizontally, through a set of fire resisting doors, into an adjacent 'sub-compartment'. Only if the fire continues to grow and threaten this adjacent fire compartment will these patients be further evacuated. Similarly, patients in the remainder of the hospital will not be evacuated unless they are threatened by the fire.

Progressive horizontal evacuation differs from phased evacuation in that, in a pha-

sed evacuation, the intention is to evacuate all occupants in a number of discrete phases. In progressive horizontal evacuation, the intention is, if safe to do so, not to evacuate. If, subsequently, evacuation is necessary, cables required for this purpose must remain undamaged.

A similar situation to that described for hospitals can apply in complex (generally low rise) interconnected buildings. It may be unnecessary to evacuate the areas most remote from a fire, but, equally, there may be a need for a facility to do so at an advanced stage in the fire if this becomes necessary. However, if the buildings were served by a networked system, and each of the independently evacuated sections were self-contained fire alarm system, cables of enhanced fire resistance would not be necessary except, possibly, in the case of the networked cables. If communication between buildings was required.

Thus, the considerations applicable to networked systems, described for phased evacuation buildings, apply in this situation.

What then of a large site, with many separate buildings, all served by a single fire alarm system, with cables for one or more buildings running through other buildings? This situation is not clearly addressed in

cabling considerations

the code. However, in fire safety design, account is not normally taken of a situation in which two independent fires occur at the same time. Accordingly, pragmatism would seem to dictate that, if the separation between buildings is such that, in the event of fire in one building evacuation of other buildings could not be anticipated, even at an advanced stage of the fire, the use of cables of enhanced fire resistance would seem to be unnecessary.

With regard to the fourth example in which the code recommends that cables of enhanced fire resistance should be used, the reason is that, in some fire engineering solutions, a reduction in the normal level of other fire protection measures may be acceptable to an enforcing authority, providing an automatic fire detection system is installed. In such a case, clearly the reliability of the automatic fire detection system must be of the highest order, since normal provisions for means of escape may have been relaxed. In such circumstances, the code leaves it to the enforcing authority to determine whether, as part of the fire engineering solution, cables of enhanced fire resistance will be necessary to satisfy legislation.

12.3 Conductor Sizes

When selecting conductor sizes, regard should be paid to physical strength and the limitations imposed by voltage drop. Voltage drop in a cable should not be such as to prevent devices from operating within their specification limits. Consideration should also be given to possible future extensions and some additional capacity left. For mechanical strength, cable conductors should have a cross-sectional area of not less than 1mm^2 .

12.4 Segregation

There are four main reasons why fire alarm cables need to be segregated from the cables of other circuits. Firstly, breakdown of cable insulation of other circuits, from which fire alarm cables are not segregated, might affect the fire alarm system. Secondly, a fault on another circuit could cause the cables of that circuit to catch fire, resulting in damage to the fire alarm cables. Thirdly, electromagnetic interference from other circuits, from which there is inadequate separation distance and/or screening, could affect the operation of the fire alarm system. Finally, strip out of other cable could result in mechanical damage to the fire alarm cables.

cabling considerations

Generally, the insulation of the cables specified for use in fire alarm systems (see 12.1) provides adequate insulation against mains voltage. Also, all acceptable cable types are fire resisting, preventing immediate damage from a fire in adjacent cables, and the cables used for fire alarm systems provide a relatively good degree of screening. Accordingly, it may be acceptable to run fire alarm cables that comply with all the above recommendations on, for example, common cable tray with mains voltage cables.

However, where practicable, fire alarm cables should not run unnecessarily long distances (e.g. more than 35m in aggregate), in close proximity to high current carrying cables, particularly if these serve high inductive loads. This is more important in the case of addressable systems than conventional systems. In order to minimize the extent to which separation from other cables is not maintained, fire alarm cables should always cross the cables of other services at right-angles.

It should also be ensured that there can be no interference between the mains voltage cables serving the fire alarm system and the lower voltage fire alarm circuits. In particular, the mains supply cable to any control, indicating or power supply equipment should not enter the

equipment through the same cable entry as cables carrying extra-low voltage. Within the equipment, low voltage and extra-low voltage cables should be kept separate to the extent practicable.

Where fire alarm cables share common trunking with the cables of other services, a compartment of the trunking, separated from other compartments by a strong, rigid and continuous partition, should be reserved solely for fire alarm cables.

12.5 Cable Colour Coding

Having segregated the fire alarm circuits from other circuits and, in the case of trunking, kept the fire alarm cables within a separate compartment from other circuits, it is important that this situation is maintained. It is also important that there is no interference with fire alarm circuits as a result of confusion between these circuits and other circuits. Accordingly, the code recommends that all fire alarm cables should be of a single, common colour that is not used for cables of general electrical services in the building. While a note in clause 26 of the code states that the colour red is preferred, it would be possible to comply with the code by using another colour, provided the same colour is not used for cables of other electrical services in the building.

cabling considerations

12.6 Joints in Cables

To ensure the integrity of the fire alarm circuits, the code recommends that cables should be installed without external joints wherever practicable. Where jointing of cables is necessary, other than in the case of joints within components of the system, the terminals used to joint the cables should be constructed of materials that will withstand a similar temperature and duration of temperature to that of the cable itself. This recommendation precludes the use of certain plastic terminal blocks. The joints should be enclosed within junction boxes, labelled with the words 'FIRE ALARM', to assist in the identification of fire alarm circuits.

12.7 Cable Support

Consideration should be given to the type of fixings used to support and/or secure fire detection and alarm system cabling and wiring. Primarily, it is the material in which the fixings are manufactured, i.e. plastic or metal, that is of importance. There would be little point in securing alarm system cables to a wall or the underside of a tray with plastic fixings if, in the event of a fire, these were to melt and allow the cables to fall and become damaged preventing the alarm condition being

given. In general, plastic cable fixings should only ever be used for fixing cables run in or on top of horizontal trays.

Metal type cable fixings should be used in all other situations. The type of fixings recommended for use in various situations are as follows:

Cables in/on Horizontal Trays

Where cables run in (or on top of) horizontal trays they should be neatly and securely fixed at suitable intervals with either plastic or metal cable ties.

Cables under Horizontal Trays

Where cables are run along the underside of horizontal trays, metal cable ties or metal P clips should be used to neatly and securely fix the cables at suitable intervals (plastic fixings must not be used).

Cables in Vertical Ducts or Shafts

Cables run in vertical ducts or shafts should be neatly and securely fixed at suitable intervals with metal cable ties or metal P clips. For long ducts and shafts, cables should be secured to staggered fixing pins so as to prevent them from stretching under their own weight.

cabling considerations

Cables in Walls

Cables run along walls should be neatly and securely fixed at suitable intervals to metal wall brackets with metal P clips. In all other respects, the installation of cabling and wiring should be undertaken generally in accordance with BS 7671 (Requirements for Electrical Installations - IEE Wiring Regulations, Seventeenth Edition).

12.8 Mechanical Protection of Cables

Mineral insulated copper sheathed cables and steel wire armoured cables may be used throughout all parts of the system without additional mechanical protection, except in particularly arduous conditions. The code recommends that other cables should be given mechanical protection in any areas in which physical damage or rodent attack is likely. More specifically, other than in relatively benign environments in which cable is clipped directly to robust construction, mechanical protection should be provided for these other cables in all areas that are less than 2m above floor level.

The term 'relatively benign environments' is not specifically defined, but, since the code gives the example of offices, shops and similar premises, in many situations, other than

certain factories, warehouses and similar premises, it will be possible to install the so-called 'soft-skinned' cables without additional mechanical protection. However, where the environment is not 'relatively benign', additional protection to these cables will be necessary, at least, everywhere that cables run less than 2m above floor level; it should be noted that this will include at least part of each 'drop' to a manual call point, since the latter devices are generally installed around 1.4m above floor level.

For the purposes of the above recommendation, additional protection may be provided by running the cable on cable tray, 'chasing in' within the building structure, or by installation of the cables in conduit, ducting or trunking. If, however, particularly arduous conditions might be experienced (such as impact by forklift trucks or goods trolleys), additional, robust protection is recommended by the code in the form of burying the cable in the structure of the building or installation in metal conduit or trunking.

communication with the fire service

13. Communication with the Fire Service

When a fire occurs in an occupied building, the most important initial action is to provide a warning to all occupants. However, the immediate summoning of the fire service is also important. Accordingly, clause 15 of BS 5839-1 is concerned purely with communication with the fire service.

The code recommends that, in occupied buildings, the primary means of summoning the fire service should always comprise a call to the fire service by occupants using the public emergency call system. This manually dialled call will usually be sufficient in the case of a Category M system, since, by definition, there must be occupants in the building in order for the alarm to be raised.

Equally, even if there is a means for transmitting alarm signals automatically to an alarm receiving centre (ARC), from where the fire brigade are then summoned, if the building is occupied a manually dialled emergency call to the fire service should still be made. In some areas of the country this manually dialled call has an additional benefit, as some fire brigades dispatch more fire appliances to a confirmed fire than to a call from an ARC.

The code recommends that the emergency call be made by a person, rather than by automatic systems that transmit a pre-recorded message direct to the fire service by the public emergency call system. In practice, the use of the now very old-fashioned 'tape 999 diallers', and even more modern equipment with digitally recorded messages, is uncommon. In any case, use of such equipment would not now comply with the code.

Often, it is pre-determined that a switchboard operator or receptionist will summon the fire brigade in the event of operation of the fire alarm system. If it is the case that an area, such as a telephone switchboard or reception desk, is specifically designated as that from which the fire service will be summoned, the code recommends that the fire alarm signal in this area should not be so loud as to interfere with telephone speech. Thus, in this area, the normal recommendations in respect of sound pressure level (see Section 9) do not apply.

13.1 Automatic Transmission of Alarm Signals

Having made suitable arrangements for immediate summoning of the fire service in the event of fire when the building is occupied, consideration should always be

communication with the fire service

given to whether there is then a need for additional automatic means of transmission of alarm signals to an ARC. Accordingly, the code recommends that the designer should determine from the purchaser or user whether such a facility is required. It should be noted that the designer has not complied with the recommendations of the code unless a specific enquiry regarding the requirement for this facility is made of the purchaser or user.

Such a facility will not normally be necessary in the case of a Category M or Category L system, since the purpose of this system is purely to facilitate evacuation in the event of fire. However, there may be circumstances in which the safety of occupants does indeed depend on the early arrival of the fire service. An example of this is a hospital. The early arrival of the fire service is vital to minimise the need to evacuate patients. This may also apply to residential care premises.

The code recommends that, if the early summoning of the fire service is considered critical to the safety of occupants, the primary means shall be by occupants using the 999 (or 112) public emergency call systems, even where automatic transmission of the alarm exists. The decision as to whether the early summoning of the fire service is critical to occupants' safety will often arise from a fire risk assessment.

13.1.1 Category L Systems

In the case of Category L systems, if the premises are unoccupied at certain times it can represent a missed opportunity, in respect of property protection, if no means for automatic transmission of alarm signals is provided. Certainly, under these circumstances, the cost of the facility in relation to the additional protection provided will often clearly point towards the value of the automatic transmission facility.

In some commercial premises in multiple occupation (e.g. an office building occupied by various tenants, or a small retail park with a common internal service corridor) there is no continuously manned reception or similar facility, occupied by someone who can be made responsible for summoning the fire service. The reliability of the arrangements for summoning the fire service might then be less than perfect. Accordingly, the code recommends that, in non-domestic premises in multiple occupation, Category L systems should incorporate an automatic means for transmission of alarm signals to an ARC, unless there are arrangements in place for summoning the fire service by occupants of the building at all times that the premises are occupied (or partly occupied).

communication with the fire service

13.1.2 Category P Systems

Since the purpose of a Category P system is to protect property, one of the primary purposes of the system is to summon the fire service. Accordingly, the code recommends that, except in the case of continuously occupied premises, all Category P systems should incorporate a means for automatic transmission of fire signals to an ARC. It should be stressed, therefore, that failure of a Category P system to incorporate such a facility constitutes a non-compliance with the code (or, if agreed with all parties, a 'variation'), unless the premises are continuously occupied.

13.2 Methods of Automatic Transmission

BS 5839-1 expresses a preference for systems in which the transmission path is continuously monitored, so that failures can be identified and the 'down time' is minimized. This implies a preference for fully monitored systems (e.g. British Telecom RedCARE) over systems that use the public switched telephone network (e.g. digital communicators). Since this preference is only expressed within the commentary, and there is not a corresponding recommendation, compliance with the code does not actually necessitate the use of monitored systems.

13.3 Standards for Alarm Receiving Centres (ARCs)

BS 5839-1 recommends that any ARC to which fire alarm signals are relayed should comply with the recommendations of BS 5979 Code of practice for remote centres receiving signals from security systems.

system installation

14. System Installation

Installation is the subject of an entirely independent section of BS 5839-1, namely Section 4. Thus, Section 4 is addressed primarily to the installer of the system. The actual responsibilities imposed on the installer by the code are relatively minimal, at least in comparison with the responsibilities placed on all other relevant parties, namely the designer, the commissioning engineers and the maintenance organization.

The code stresses that it is not, in general, the responsibility of the installer to check or verify whether the design of the system complies in full with the recommendations of the code, unless, of course, the installer is also the designer. It is, therefore, very important that responsibilities for design, installation and commissioning are clearly defined and documented before an order is placed for the system.

In practice, compliance with a number of the design recommendations of the code impact on installation, and compliance may, therefore, be delegated by the designer to the installer. However, this needs to be made clear in any specification or contract, so that the installer accepts responsibility for the issues in question, and

it is necessary for the installer to be competent to address the issues in question. Such issues will, therefore, often be limited to matters that it is reasonable to expect any competent electrical contractor to address. An example is cable routes; often, these are not determined by the designer, but are left to the installer to determine. Under these circumstances, in a specification, the designer may refer to the relevant clause of the code, which could reasonably be imposed, in part, on the installer.

At the design stage, it can be very difficult for the designer to ensure compliance with all relevant recommendations of the code. The obvious example in this respect concerns sound pressure levels, and it might be reasonable, within a specification, to require that the installer carry out measurements of sound pressure level, before commissioning, so that any additional sounders required can be installed before the somewhat late stage in a project at which commissioning is carried out.

Even so, the code considers, in effect, that the designer should not glibly assume that the installer of the system will have expertise in the design of fire alarm systems. Therefore, it is the responsibility of the designer to provide sufficient information and guidance to the installer to enable the

system installation

installer to satisfy the relevant recommendations of Section 2 of the code (which covers design).

14.1 Siting of Equipment

The installer will be responsible for fixing control, indicating and power supply equipment. The code recommends that all such equipment that is likely to need routine attention for maintenance should be sited in readily accessible locations that facilitate safe maintenance. It is further recommended in the code that all metallic parts of the installation, including conduit, trunking, ducting, cabling and enclosures, should be well separated from any metalwork forming part of a lightning protection system.

14.2 Installation Work

With regard to the actual installation work, the code expects little more than that the installer should conform to the requirements of BS 7671, albeit that, where any conflict between BS 5839-1 and BS 7671 exists (which is unlikely), BS5839-1 should take precedence. Particular conventional good practices that are highlighted in clause 37 of the code, include proper fixing of cables, so that, for example, they do not rely on suspended ceilings for their sup-

port, avoidance of unnecessary joints, proper arrangements for earthing, with care taken to ensure the electrical continuity of electromagnetic screens, including metallic sheaths of cables.

Recommendations are also given in clause 37 for fire stopping of penetrations for cables, conduits, trunking or tray, and for fire stopping within ducts, trunking, shafts, etc that pass through floors, walls, partitions or ceilings. Recommendations are also given to ensure that cables are not damaged as they pass through penetrations in construction and that penetrations in external walls are suitably sleeved.

Clause 37 recommends consideration of some of the recommendations in Section 2 of the code. However, once again, these are primarily recommendations that relate to practical installation considerations, such as segregation, protection of cables against mechanical damage and support of cables, rather than matters of fundamental design, such as whether cables should be of standard or enhanced fire resistance; the latter issue is purely one for the designer to specify.

Generally, it is responsibility of the installer to provide 'as fitted' drawings of the system, showing the locations of equipment, cable

system installation

routes, cable sizes and types, etc. The view taken in the code is that, by default, unless it has been agreed that the preparation of 'as fitted' drawings is to be the responsibility of others, it is the responsibility of the installer to supply these to the purchaser or user of the system. On completion of installation work, the installer should also issue a certificate of installation. Annex G of the code contains a model certificate for this purpose.

An electricity supply from a card or coin meter is unacceptable.

14.3 Inspection and Testing

Clause 38 of BS 5839-1 deals with inspection and testing of wiring. This clause is included within Section 4 of the code ('Installation') because, of course, this work is normally carried out by the installer.

In practice, any competent contractor who installs electrical wiring, whether as part of a fire alarm installation or any other form of electrical installation, will 'megger' test the wiring to confirm that the insulation resistance is adequate. The code recommends that insulation testing should be carried out at 500 V d.c., unless the cables are not rated for mains voltage; in practice, cables used within the system will be ra-

ted for mains voltage, albeit that fire alarm systems operate at extra low voltage. This initial 500 V test is useful in identifying incipient defects that might not come to light from testing at a much lower voltage and that might not be identified by the system's fault monitoring; problems might, however, arise during the lifetime of the system.

The code recommends that insulation resistance be measured between conductors, between each conductor and earth, and between each conductor and any screen. In practice, when such a test is carried out on newly installed wiring, a reading of infinity will be obtained, or, at least, the meter will indicate a higher resistance than the 100 M Ω that is often the maximum value that the meter can accurately read. Although this will invariably be achieved with properly installed and undamaged cable, such high resistance is not actually necessary for operation of the system. A certificate covering the mains supply installation should be provided.

The code recommends that the insulation resistance measured in these tests should be at least 2 M Ω . In practice, if such low insulation resistance is found in newly installed cables, it almost implies the existence of a potential fault that might result in instability in the degree of insulation

system installation

resistance afforded. Moreover, the code does contain a 'health warning' in the form of a note that draws attention to the fact that, in large systems, the insulation resistance would need to be much higher if control and indicating equipment has a means for sensing resistance between conductors and earth, otherwise nuisance fault indications might result. On the other hand, for a small non-addressable system of up to about four zones, 2 M Ω might be acceptable.

Since the installation is an electrical installation to which BS 7671 applies, obviously, further tests should be carried out to ensure compliance with BS 7671. Thus, the code draws attention to the need for earth continuity testing and, in the case of mains supply circuits, for measurement of earth fault loop impedance.

Since the insulation resistance tests need to be carried out with equipment disconnected, further tests might need to be carried out on the final completion of the system. The code makes the installer responsible for carrying out these tests, unless there is specific agreement that they will be carried out as part of the commissioning process. In the case of an addressable system, would specify a maximum resistance for any loop. Thus, one of the

further tests recommended by the code is measurement of the resistance of any circuit for which a maximum circuit resistance is specified. As a final 'catch all', the code also recommends that the installer carry out any other tests specified by the manufacturer of the system, unless, again, there is specific agreement that these tests will be carried out as part of the commissioning process.

The results of all tests described above, should be recorded and made available to the commissioning engineer. Thus, completion of the model installation certificate contained in Annex G of the code requires that the installer confirm that wiring has been tested in accordance with the recommendations of clause 38 and that test results have been recorded. The model certificate contains space for the installer to record the person to whom these test results have been provided.

14.4 Commissioning and Handover

Commissioning and handover are the subject of Section 5 of the code. In practice the code tends to regard commissioning as merely setting the system to work and verifying that it operates correctly in the manner designed. The commissioning engineer is also expect-

system installation

ted to ensure that installation workmanship is generally of an adequate standard and that all relevant documentation has been handed over to the user.

However, the code acknowledges that it is not, in general, the responsibility of the commissioning engineer to verify compliance of the design, or of the installation work, with the recommendations of the relevant sections of the code (i.e. Sections 2 and 4 respectively). Equally, the code recognizes that, as in the case of installation, it may be difficult to ensure that the system complies in full with certain recommendations of Section 2 until the time of commissioning; adequacy of sound pressure levels is an obvious example (unless adequacy of sound pressure levels throughout the building has been carefully checked during the installation process). Similarly, information about structural features of the building, or final layout, might not have been available to the designer. Commissioning is, in effect, the final 'safety net' for obvious shortcomings in design to be identified.

In order to commission the system properly, the commissioning engineer will need to be furnished with the specification for the system. The commissioning engi-

neer should also have a basic knowledge and understanding of Section 3 of the code, and the recommendations it makes in respect of limiting false alarms, so that he can verify compliance with, at least, the principles discussed in Section 3.

The code sets out a list of 27 matters that are to be checked during the commissioning process. These, obviously, include testing all devices in a suitable manner and confirming that the system's 'cause and effect', as specified by the designer, is correctly programmed and demonstrated as compliant with the specification; thus, it should be confirmed that, for example, every manual call point and automatic fire detector, on operation, results in the correct zone indication, correct text display (if the system is addressable), and that all plant shutdowns, etc operate correctly.

The code also recommends that sound pressure levels throughout all areas of the building are checked for compliance with the recommendations of the code. If the installation incorporates a voice alarm system, it should be confirmed that intelligibility is satisfactory. Visual alarms should be checked to ensure compliance with clause 17 of BS5839-1; that there are sufficient numbers to be visible, distinguishable and

system installation

operating within a compliant flash rate in accordance with EN54-23. A check is also necessary to ensure that no changes to the building, since the time of original design, have compromised the compliance of the system with the code (e.g. by a final fit out that affects the adequacy of device siting).

As in the case of the installer, the commissioning engineer is not expected to confirm that the siting of all devices meets the detailed design recommendations of the code. For avoidance of doubt as to the commissioning engineer's responsibilities in this respect, the code specifies the particular recommendations within Section 2 that should be verified at commissioning. The recommendations that are cited relate primarily to practical considerations, such as proximity of detectors to walls, partitions, obstructions and air inlets. Similar practical considerations in the siting of control, indicating and power supply equipment are recommended for verification, along with a check that a suitable zone plan is displayed.

The commissioning engineer is also expected to inspect the mains power supplies, as far as is reasonable practicable, to ensure compliance with the recommendations of the code. The code also recommends that the commissioning

engineer confirm that standby power supplies comply with the recommendations of the code for these supplies. This will require actual measurement of quiescent and alarm currents, and the use of the formula given in Annex D of the code (see Section 11).

A check should also be carried out to ensure, as far as is reasonably practical, that the correct cable type has been used throughout the system and that installation workmanship complies with the relevant recommendations of the code. It should be noted that, at commissioning, very little of the cable may be visible, and certainly it will be difficult to confirm that every length of cable is suitably supported.

Often, batteries are not fitted until the time of commissioning. Accordingly, the code recommends that labels, visible when batteries are in their normal position, should be fixed to batteries, indicating the date of installation.

While it is not the responsibility of the commissioning engineer to verify or certify compliance of system design with the code, the code does recommend that the commissioning engineer confirm that there are no obvious shortcomings in compliance with Section 2 of the code. Thus,

system installation

It would be expected that the commissioning engineer identify the existence of unprotected areas within a Category L1 or P1 system, or obvious errors in the spacing or siting of detectors.

The code recommends that the commissioning engineer confirm that adequate records of insulation resistance, earth continuity and, where appropriate, earth loop impedance tests exist. It is also recommended that the commissioning engineer confirm that all relevant documentation has been provided to the user or purchaser; the nature of this documentation is discussed in the next section of this guide.

On completion of commissioning, a commissioning certificate should be issued. Completion of the model certificate contained in Annex G of the code requires that the commissioning engineer confirm that the system has been commissioned in accordance with the code, other than any recorded variations from the recommended commissioning process. Completion of the certificate also requires that it be confirmed that all equipment operates correctly, installation work is, as far as can be reasonably ascertained, of an acceptable standard, that there is no any obvious potential for an unacceptable rate of false alarms and that the required documentation has

been provided to the user. The certificate should also record an appropriate period for which a soak test should be carried out (see Section 8). There is also space on the commissioning certificate for the commissioning engineer to record potential causes of false alarms that, while not warranting specific action at the time of commissioning, should be considered at the time of the next service visit to determine whether false alarm problems are arising.

documentation

15. Documentation

In a highly modular contract, in which design, installation, supply and commissioning are undertaken by a number of different parties, more than one party may be involved in provision of the documentation recommended by BS 5839-1. To address this point, the responsibility for provision of documentation needs to be defined before an order for the system is placed. In addition, the organization to which each form of documentation is provided needs to be defined in any contract for design, supply, installation and commissioning of the system. For example, some documentation might be provided to a main contractor (e.g. by an installation sub-contractor), rather than directly to the user or purchaser. Therefore, as noted in Section 14, at commissioning it needs to be ensured that, either the documentation has been provided to the relevant parties, or that any absent documentation is identified for appropriate action.

The documentation recommended by BS 5839-1 comprises the following:

- Certificates for design, installation and commissioning of the system.
- An adequate operation and maintenance (O&M) manual for the system.

- As fitted' drawings.
- A log book.
- A record of any agreed variations from the original design specification.
- Such other records as are required by any purchase specification.

Separate certificates may exist for design, installation and commissioning (i.e. if each of these processes is undertaken by a different party). If more than one of these three processes, including all three of them, are undertaken by a single party, it would be reasonable, and probably more convenient for the recipient in any case, to provide a single certificate that covers the processes for which the signatory has been responsible.

The O&M manual should provide information, specific to the system in question, and the information provided should include the following:

1. The equipment provided and its configuration.
2. Use of all controls.
3. Recommendations for investigation of a fire alarm or fault signal after the incident is over and the building is declared safe for re-occupation.

documentation

(This is not, however, intended to be the emergency or evacuation plan, which is the responsibility of the occupant to formulate.)

4. Recommendations for investigation in the event of a false alarm.
5. Routine weekly and monthly testing of the system by the user or his appointed agent.
6. Service and maintenance of the system in accordance with Section 6 of the code.
7. Avoidance of false alarms (based on the information contained in Section 3 of the code).
8. The need to keep a clear space around all fire detectors and manual call points.
9. The need to avoid contamination of detectors during contractors' activities.
10. The importance of ensuring that changes to the building, such as relocation of partitions, do not affect the standard of protection.
11. Other user responsibilities described within Section 7 of the code.

The minimum information that should be provided on all 'as fitted' drawings comprises:

1. The positions of all control, indicating and power supply equipment.
2. The positions of all manual call points, fire detectors and fire alarm devices.
3. The positions of all equipment that may require routine attention or replacement (the obvious example is short circuit isolators).
4. The type, sizes and actual routes of cables.

Cable routes shown need to comprise a reasonable representation of the route followed, such as to enable a competent person to locate the cable in the event of a fault or need for modification or extension of the system.

maintenance

16. Maintenance

Once the system is handed over to the user, there will be a need for it to be maintained, so that it continues to provide the protection that it was designed to give. This will necessitate regular testing by the user and periodic servicing by specialists.

16.1 Routine Testing

The routine testing recommended in BS 5839-1 is not intended to overlap significantly with the benefits afforded by system monitoring. The testing that is recommended is very basic in nature, and it can be implied from the recommendations of the code that it really only has two principal functions.

The first of these is to ensure that the system has not suffered some form of catastrophic failure, such as total power failure or major circuit failure. In pursuit of this confirmation, the code recommends that, every week, just one manual call point should be operated. The purpose of this test is only to ensure that the control equipment is capable of processing a fire alarm signal, if one occurs, and can provide an output to fire alarm sounders. If there is a facility for transmission of fire alarm signals to an alarm receiving centre, it should

also be ensured that the signal is correctly received at the alarm receiving centre. To avoid any confusion between the weekly test and a genuine fire alarm signal, the code now recommends that the duration for which fire alarm sounders should operate at the time of the weekly test should not normally exceed one minute.

The second, but more subsidiary, objective of the weekly test is to make occupants familiar with the fire alarm signal. For this reason, the code specifically recommends that the weekly test should be carried out during normal working hours. It is also recommended in the code that the test be carried out at approximately the same time each week. In systems with staged alarms, incorporating an 'Alert' and an 'Evacuate' signal, the two signals should be operated, where practicable, sequentially in the order that they would occur at the time of a fire. This is to minimize the chance of confusion between the 'Alert' and 'Evacuate' signals.

In some premises, certain occupants may work only at times other than that at which the fire alarm is tested. An example would be permanent night shift workers. To ensure that these employees are also made familiar with the sound of the fire alarm system, the code recommends that, in such cases, an additional test(s) be carried out

maintenance

at least once a month to ensure the familiarity of these employees with the fire alarm signal(s).

While the objective of the weekly test is not to test all manual call points at any particular frequency, as a form of 'bonus', the code recommends that a different manual call point should be used at the time of every weekly test. The purpose of this is to capitalize on the test to give some opportunity to identify a defective manual call point. Since, however, this is merely something of a bonus, the code acknowledges that, for example, in a system with 150 manual call points, each manual call point will only be tested by the user every 150 weeks. To ensure the rotation in testing manual call points, the code recommends that the identity of the manual call point used in the weekly test should be recorded in the system log book.

If an automatically started emergency generator is used as part of the standby power supply for the fire alarm system (i.e. the relaxation in battery capacity offered by the code is adopted), there will be a need for routine testing of the generator. The code recommends that, in this case, the generator is started up once each month by simulation of failure of normal power supply and operated on-load for at least

one hour, after which fuel tanks should be left filled, and oil and coolant levels should be checked and topped up as necessary.

If vented batteries are used as a standby power supply, a monthly visual inspection of the batteries and their connections should be carried out. In particular, electrolyte levels should be checked. In practice, the use of vented batteries in fire alarm systems is now uncommon, but occasionally it occurs in premises that contain large battery banks for other purposes (e.g. some power stations).

16.2 Servicing

Periodic inspection and servicing are necessary so that unrevealed faults are identified, preventive measures taken, false alarm problems identified and addressed, and that the user is made aware of any changes to the building that affect the protection afforded by the system. The last of these points is particularly important.

The periodic inspection and servicing of the system needs to be carried out by a competent person with specialist knowledge of fire detection and alarm systems. BS 5839-1 advises that this should include knowledge of the causes of false alarms. The person carrying out the work should

maintenance

have sufficient information regarding the system and adequate access to spares.

BS 5839-1 recommends simply periodic inspection and testing of the system, rather than specifying an exact frequency at which this should be carried out. The code recommends that the period between successive inspection and servicing visits should be based upon a risk assessment, taking into account the type of system installed, the environment in which it operates and other factors that may affect the long term operation of the system. However, the code does recommend that the period between successive inspection and servicing visits should not exceed six months. If the risk assessment shows the need for more frequent inspection and servicing visits, the code recommends that all interested parties should agree the appropriate inspection and servicing schedule.

BS 5839-1 recommends annual testing of all manual call points and automatic fire detectors. The test recommended for each type of detector is a functional test. For example, it would not be sufficient to rely purely on measurement of digital values at the control equipment of an addressable system (although the code

also recommends that these values be checked every twelve months).

If quarterly servicing is adopted, 25% of all detectors can be tested at the time of each quarterly visit, so that all detectors are tested on an annual basis. If six monthly servicing is adopted, either all detectors will need to be tested at the time of each alternate visit, or 50% of the detectors would need to be tested at each service visit.

The code provides recommendations on other measures that should be carried out on a twelve monthly basis, including a visual inspection to confirm that all readily accessible cable fixings are secure and undamaged, and confirmation that the entire 'cause and effect' program of the system is correct.

responsibilities of user

17. Responsibilities of User

It is not expected that the typical user will purchase a copy of BS 5839-1. However, in the code, it is recommended that appropriate information be provided to the purchaser or user. The organization responsible for the provision of documentation needs to be identified in the fire alarm contract.

BS 5839-1 recommends the appointment of a 'responsible person'. This term is defined in the code as the person having control of the building and/or premises, whether as occupier or otherwise, or any person delegated by the person having control of the building and/or premises to be responsible for the fire alarm system and the fire procedures. The code recommends that this person be given sufficient authority to carry out the duties described in the code, and that this person should normally be the keeper of the documentation recommended in the code. The primary duty of the responsible person is to ensure that:

- The system is tested and maintained properly.
- Appropriate records are kept.
- Relevant occupants in the premises are aware

of their roles and responsibilities in connection with the fire alarm system.

- Necessary steps are taken to avoid situations that are detrimental to the standard of protection afforded by the system.
- Necessary steps are taken to ensure that the level of false alarms is minimized.

The implications of these objectives relate to testing, maintenance, keeping of documentation and proper system management. The responsible person should also ensure that the control and indicating equipment is checked at least once every 24 hours to confirm that there are no faults on the system. It is also the responsibility of the responsible person to ensure that suitable spare parts for the system are held within the premises; the code gives guidance on the nature of these.

The user should also ensure that the system receives non-routine attention (usually by specialists) as appropriate.

section one | guide to design, installation, commissioning and maintenance of fire systems in non domestic premises

responsibilities of user

This includes:

- A special inspection by any new servicing organisation when they take over responsibility for servicing the system.
- Repair of faults.
- Action to address any unacceptable rate of false alarms.
- Inspection and test of the system following any fire.
- Inspection and test of the system following long periods of disconnection.
- Modification of the system as required (e.g. to take account of changes to the building).



Section two

An Introduction to the suite of EN54 standards

introduction

Overview

The Harmonisation of Standards for the design and manufacture of Fire Alarm and Detection Equipment.

Introduction

The European Committee for Standardisation, (CEN) is the organisation covering trade, welfare and the environment and who develop and maintain specifications and standards, the latter which when harmonised become law under the CPR. The CPR relates to products used in the course of construction. Proof of compliance is the CE marking.

Products for use as Fire Detection and Fire alarm systems are regulated by a set of standards referenced EN54. Standards that are in the process of being written are prefixed with the letters pr. Once written and agreed it becomes a harmonised standard, which under the EU Regulation applies in all EU member states and therefore has the status of being a national standard within that country. Annex ZA of each standard deals with the clauses of the standard in respect of their compliance with the mandate of the EU construction products regulation.

All products built to EN54 standards are tested by independent third party organisations, of which there are several, across various member state countries. The testing of products is vigorous and comprehensive as will be seen from the individual standards. Approval whilst being mandatory within the EU also proves reliability and longevity as well as sensitivity which together are some of the most essential components of both life safety and property protection systems.

The aim of the following document is to provide an overview of each of the current harmonised standards, whilst not negating the need to consult, at times, both the full EN54 standard document together with other supporting documents, such as the ISO/IEC 6000 series of publications.

Foreword

These standards replace all previous versions and have the status of being national standards in all EU member states and therefore support the essential requirements of the EU regulations.

All devices should be clearly labelled with the manufacturers name or logo, part number, electrical connection detail and any further information which provides a means to identify the place and

introduction

date of manufacture, batch and software versions. For detachable units both parts should be labelled. All labelling should use symbols or abbreviations which are in common use, otherwise such information should be explained in supporting documentation. The labelling should be permanent and clearly visible at all times. Documentation shall be provided, prior to testing, which provides an aid to both installer, maintainer and user, giving a general description, detail of the device and which will support any compatibility assessment to be undertaken, as detailed in EN54-1, including power requirements, input/output ratings, transmission paths, battery capacities, current and internal resistance levels. Information relative to the connecting cables, environmental protection, and mounting and connection detail together with operating and maintenance instruction shall also be provided.

If on site adjustment of the device's response type is provided, the data shall clearly indicate the classification, means of adjustment or programming instructions.

Configuration data relevant to the compliance with a standard shall be stored in non-volatile memory and access shall be password protected or by use of a special

tool and shall only be possible when the device is taken out of normal service.

EN54- description of Test Schedules

Operational performance, to prove that the specified sound levels can be achieved across the voltage range, and that the maximum sound level does not exceed 120 dB(A) at 1 m. (EN54-3)

Additional testing for voice sounders, to verify that the output level of the broadcast message in relation to that of the alert signal is sufficient. To verify the timing between the alert signal, the silence before and after the message and before the next alert signal, is within the limits set in table C1 of appendix C of EN54-3.

Durability, to show that the sound level does not change significantly after prolonged operation.

Operational performance and functional tests are to show the call point's ability to withstand small forces when applied to the frangible element and to operate correctly and only when an appropriate force is applied, all without damage to the test and reset functions which are also tested.(EN54-1 11)

introduction

Dry heat (operational), to establish the equipment functions correctly at high ambient temperatures for short periods

Dry heat (endurance), to establish the equipment can withstand long-term ageing effects.

Cold (operational), to establish the equipment functions correctly at low ambient temperatures

Damp heat, cyclic (operational), is to prove the immunity of the equipment where high relative humidity exists and where condensation may occur on the device.

Damp heat, cyclic/steady state (endurance), is to establish the equipment's ability to withstand the longer-term effects of high humidity and condensation.

Damp heat, steady state testing demonstrates the ability of the equipment to function at high relative humidity (without condensation), for short periods

Sulphur dioxide (SO₂) corrosion (endurance), to establish the sounder can withstand the corrosive effect of sulphur dioxide as an atmospheric pollutant.

Shock (operational), is to establish the immunity of the equipment to infrequent mechanical shocks.

Impact test is to demonstrate the immunity of the equipment to mechanical impacts.

Vibration, sinusoidal (operational), is to display the equipment's immunity to normal levels of vibration.

Vibration, sinusoidal (endurance), is to display the equipment's ability to withstand the long-term effects of vibration

Electromagnetic compatibility (EMC), immunity tests (operational), tests are carried out in accordance with EN50130-4 and include electrostatic discharge, radiated electromagnetic fields, induced effects from electromagnetic fields, fast transient bursts and slow high energy voltage surges.

Electromagnetic Compatibility (EMC), Immunity tests are designed to demonstrate immunity to electrostatic discharges caused by personnel, who may have become charged, touching the equipment or other adjacent equipment.

Electromagnetic Compatibility (EMC), is to show the manual call points ability to comply with the EMC immunity requirements in its normal service environment. (EN54-11)

introduction

Enclosure protection, to establish that the degree of protection provided by the enclosure of the fire alarm equipment, meets the minimum requirements for its type.

Repeatability, demonstrates a detectors stable sensitivity, during multiple alarms.

Directional dependence, to prove that performance is not dependent upon a specific airflow

Directional dependence, to demonstrate that the detector is sensitive to detecting radiation across its entire field of view (EN54-10)

Fire sensitivity, to prove that the detector has sufficient sensitivity to fire, and to determine a classification based on its detection range (EN54-10)

Reproducibility: to demonstrate that response times are within the specified limits and that the response times do not vary significantly during repeat testing.

Variation in supply parameters: to prove that within the equipment's specified voltage range the performance /response times are reasonably constant.

Air movement, is to demonstrate that the sensitivity of a detector does not sig-

nificantly change in an air flow, and is not prone to false alarms in draughts or in short gusts.

Dazzling, is to demonstrate that the sensitivity of a detector does not significantly change when close to artificial light sources. (Applies only to optical detectors).

Fire sensitivity, is to demonstrate a detectors sensitivity to a broad spectrum of smoke types as required for general application in fire detection systems. (EN54-7)

Test Fires. The detectors shall be subjected to four test fires TF2 to TF5 (as detailed in Annexes G to J). The procedures are described for each test fire, along with the end of test condition and the required profile curve limits. The test fire numbers have been retained from EN 54-9. All detectors shall generate an alarm signal, in each test fire. (EN54-7).

Note: In the UK all EN standards are prefixed with BS, e.g. BS EN54-2

Note: all standards are referenced with a date and suffix to any amendments and corrigenda which have been issued since the original standard was published.

introduction

Foreword

This standard replaces all previous versions and has the status of being a national standard in all EU member states and therefore supports the essential requirements of the EU directive(s).

Introduction

The EN54 standard, part 1 explains the use of each part of the EN54 suite of standards. The standards apply to systems used for the early detection of fires in buildings, including providing warnings both locally and remote and operating other fire precautions, such as water or gaseous suppression systems. Consideration should be given if these standards are used for systems installed in other than building applications, as to their suitability.

Each standard covers the requirements, test and performance criteria, for measuring the reliability of the system component parts which together form the complete system. The tests are designed to prove their performance under varying conditions which they are likely to be subjected to during their lifetime.

Some standards listed below are published as harmonised standards. However some are relatively new and others are still

in the process of preparation and some may not be EN54 standards.

Parts 16, 24 and 32 refer to voice alarm equipment which may form a separate and sub system to the fire alarm and detection system, but which when interconnected will effectively work as a complete system. Part 32 is a guide to installation which, in the UK, would not replace BS5839-8

EN54-22 and 28 are draft standards covering line type heat detectors and resettable types.

Part 23 covers visual alarm devices which may be installed to compliment audible devices in noisy areas or to provide a warning to hearing impaired personnel.

Part 26, covers CO fire detectors, i.e.. detectors which detect the presence of the combustion gas, Carbon Monoxide, from a fire. It is anticipated that all conflicting national standards will be withdrawn by 2019.

Part 27, covers duct smoke detectors. It is anticipated that all conflicting national standards will be withdrawn by 2019.

introduction

Parts 29, 30 and 31 cover multi sensor detection devices which may detect different fire phenomena providing a wider spectrum of detection capability than a standard single technology device. The various detection channels of these devices can be combined in software to provide either more resilience or increased sensitivity dependent upon the risk and environment. Currently ISO 7240- 8 and 15 and CEA 4021 are all published documents covering some types of multi sensors. It is anticipated that all conflicting national standards will be withdrawn by 2019.

Part 13 of the standard assesses the compatibility of components, which although individually approved to the relevant standard, have been assessed when working together as a system. This standard, whilst being the only published standard is not harmonised and is therefore not enforced under the Construction Product Regulation. It does however offer sound practical guidance to building networked systems. Clause 4 of this Standard specifies both input and output functions associated with the fire detection and fire alarm system. Table A.1 (below), gives examples of products that fulfil these functions and references these to the applicable published standards

Annexes to EN54-1

A- Functions, examples and relevant standards, Clause 4 of this European Standard specifies functions and equipment of the fire detection and fire alarm system and associated systems. Table A.1 in Annex A gives examples of products that carry out the specified functions and gives information on relevant published standards applicable to these products and systems.

section two | an introduction to the suite of EN54 standards

introduction

Table A.1 – Examples of products and systems carrying out the functions of FDAS and associated systems and applicable relevant standards

Reference	Functions	Example of product carrying the function	Relevant standards
A	Automatic fire detection function	<p>Fire detectors such as:</p> <p>Smoke detectors (point detectors)</p> <p>Line smoke detectors using optical beam</p> <p>Aspirating smoke detectors</p> <p>Duct smoke detectors</p> <p>Heat detectors (point detectors)</p> <p>Line type heat detectors)</p> <p>Line type heat detectors, non-resettable</p> <p>Flame detectors (point detectors)</p> <p>Carbon monoxide fire detectors (point detectors)</p> <p>Multi-sensor fire detectors:</p> <p>Point detectors using a combination of smoke and heat sensors</p> <p>Point detectors using a combination of carbon monoxide and heat sensors</p> <p>Point detectors using a combination of smoke, carbon monoxide and optionally heat sensors</p> <p>Input device for auxiliary detection functions such as:</p> <p>Sprinkler activated input</p> <p>Input device for connection of secondary detection circuit to a Primary detection circuit</p>	<p>EN54-7</p> <p>EN54-12</p> <p>EN54-20</p> <p>EN54-27</p> <p>EN54-5</p> <p>EN54-22</p> <p>EN54-28</p> <p>EN54-10</p> <p>EN54-26</p> <p>EN54-29</p> <p>EN54-30</p> <p>EN 54-31</p> <p>EN 54-18a</p>

introduction

Table A.1 — Examples of products and systems carrying out the functions of FDAS and associated systems and applicable relevant standards

Reference	Functions	Example of product carrying the function	Relevant standards
B	Control and indication function	Control and indicating equipment (CIE), in conjunction with: Networked control and indicating equipment's Fire brigade panel	EN 54-2 EN 54-13
C	Fire alarm function	Voice alarm loudspeakers Fire alarm devices such as: Fire alarm sounders Visual alarms Tactile alarm devices	EN 54-24 EN 54-3 EN 54-23
D	Manual initiating function	Manual call points	EN 54-11
E	Fire alarm routing function	Fire alarm routing equipment (alarm transmission routing equipment)	EN 54-21
F	Fire alarm receiving function	Fire alarm receiving centre	EN 50518

section two | an introduction to the suite of EN54 standards

introduction

Table A.1 — Examples of products and systems carrying out the functions of FDAS and associated systems and applicable relevant standards

Reference	Functions	Example of product carrying the function	Relevant standards
G	Control function for fire protection system or equipment	Output device to trigger fire protection equipment Output to fire protection equipment	EN 54-18 _a EN 54-2
H	Fire protection system or equipment	Duct mounted fire dampers Electrically controlled hold-open device for fire/smoke doors Smoke and heat control systems Fixed fire fighting systems: gas extinguishing systems Fire fighting systems: sprinkler or water spray systems Other fire protection measures	EN 15650 EN 14637 EN 12101 series EN 12094 series EN 12259 series
J	Fault warning routing function	Fault warning routing equipment	EN54-21
K	Fault warning receiving function	Fault warning receiving centre	EN50518

introduction

Table A.1 — Examples of products and systems carrying out the functions of FDAS and associated systems and applicable relevant standards

Reference	Functions	Example of product carrying the function	Relevant standards
L	Power supply function	Power supply equipment (PSE)	EN54-4
M	Control and indication function for alarm annunciation	Voice alarm control and indicating equipment (VACIE) Control for other fire evacuation measures	EN 54-16
N	Ancillary input or output function	Data communication interface	
O	Ancillary management function	Visualization system Building management system	
↔	Exchange of information between functions	Short-circuit isolators Components using radio links Alarm transmission systems such as: series LAN/WAN PSTN GSM GPRS	EN 54-17 EN 54-25 EN 50136
<p>^a EN 54-18 does not include detailed functional requirements for the input/output devices but requires that their function is sufficiently specified by the manufacturer and that the CE attestation of conformity assesses that they function correctly in accordance with the manufacturer's specification</p>			

Part 2 control and indicating equipment

Introduction

The standard covers both mandatory and optional functionality with regards to the system control and indicator equipment. The “optional functions” allows for specific functions associated with requirements which may not be standard but still allows the products to comply. The options covered in annex B are those already used by some member states and have therefore been included in this standard and may also form part of their local national standard.

Requirements

The control and indicating equipment shall be capable of being in, and also displaying indication appropriate to, Fire, Fault, disablement, and where provided, test. The rules governing alphanumeric displays are also listed. An indication of external power shall be provided. Any other kind of indication may be displayed, however all indications must be clear and unambiguous.

Audible indication, indicating a change of state shall be provided within the control and indicating equipment and shall be capable of being silenced, but not automatically. The audible alarm should resound for each subsequent event.

A reset function shall be provided and be used for both fire and fault, with the current status of the system, including points not reset being displayed within 20 seconds.

Output of the fire alarm condition may be signalled to numerous devices, including audible alarms, visual alarms, transmission equipment and other fire protection systems, with at least one output being mandatory.

Time constraints are detailed in this section, being 10 seconds, if no delays are programmed. Delays and coincidence are recognised as being acceptable in some cases with delay timers being programmable up to a maximum of 10 mins. The rules relating to these functions are detailed within the standard. The equipment may include provision to record the number of fire alarm events.

Fault recognition and indication is covered in respect of the various categories of fault which could occur. These include faults within and external to the control and indication equipment. These are prioritised into three groups, faults in specified functions, power loss and system faults. The implications of each can be quite different. Faults shall be processed and their status indicated within 100 secs.

control and indicating equipment

In the event of a mains power loss, the equipment shall have the ability to recognise if the standby supply is capable of providing at least the mandatory system function, otherwise an audible indication shall be sounded for a period of at least 1 hour.

Disablements may be applied to inputs and outputs, such as zones, audible and visual devices and signal transmission paths. Such disablement should only affect those linked indications and outputs and not be global. Indications of disablements shall be provided both generally and for specific disablements.

Indication of a Test Condition shall be displayed whenever any part of the system is under test. Those parts of the system under test must be clearly displayed and all mandatory indications from those parts of the system not under test will still be provided. Tests must be started and ended manually. Outputs from those zones under test will not be triggered by the test.

The Input/output Interface is an approved method of communicating between the main control and indicator panel and a sub panel capable of performing functions associated with the cause and

effect, such as operating a fire protection system or communicating with the fire brigade. The sub panel is not a part of the main control and indicator panel under this standard; however the minimum functional requirements regarding the interface are clearly detailed. Where the sub panel is a fire brigade panel and because requirements vary from country to country, the specified interface functions negate the need for the panel specification to be harmonised under this standard. Most panels will be approved locally.

Design Requirements for the control and indicator panel are listed in clause 12 of the standard. Not all panel functionality can be tested therefore manufacturers are required to confirm compliance in accordance with the standard by way of documentation. Both electrical and mechanical details are included in the standard as is the integrity of its transmission paths, the accessibility of indicators and controls, the specification for indicator lights, including colours, alphanumeric displays, and audible indications. The panel's software and software processing methods together with the means of storing both programmes and data are also detailed.

control and indicating equipment

The panel will be clearly labelled, including the ref to the standard, the manufacturers logo and model number.

Testing of the main control and indicator panel is carried out in a test environment with a specimen configuration loaded

into the panel. The test objectives are to prove the operation of the equipment and to enable this; a test schedule is drawn up prior to testing. Testing will prove the fire alarm, fault and disabled conditions. Environmental tests are carried out in accordance with table 1, below.

Table 1. Environmental tests

Test	Operational or endurance	Sub-clause number
Cold	Operational	15.4
Damp heat, steady state	Operational	15.5
Impact	Operational	15.6
Vibration, sinusoidal	Operational	15.7
Electromagnetic compatibility (EMC) immunity test	Operational	15.8
Supply voltage variations	Operational	15.13
Damp heat, steady state	Operational	15.14
Vibration, sinusoidal	Operational	15.15

control and indicating equipment

Table B.1 Optional functions

Option	See clause
Indications: Fault signals from points Total loss of power supply Alarm counter	8.3 8.4 7.13
Controls: Dependency on more than one alarm signal Delays to outputs Disablement of each address point Test condition	7.12 7.11 9.5 10
Outputs: Fire alarm device(s) Fire alarm routing equipment Automatic fire protection equipment Fault warning routing equipment Standardized I/O interface	7.8 7.9 7.10 8.9 11

control and indicating equipment

Annexes to EN54-2

Annex A- Explanation of Access Levels, defines these for all mandatory functions detailed within the standard.

Annex B (informative) Optional functions with requirements and alternatives.

As described earlier this standard confirms those mandatory functions necessary to comply together with some optional functions which might also be provided. The optional functions described in this standard which have already been adopted by some countries are listed in table B1 below.

Annex C; refers to the processing of signals, where appropriate, from a fire detector to a point in the process where a decision is made.

Annex D; provides an explanation of the zones and their appropriate indications, together with the limitations regarding device loading.

Annex E; explains the process of delaying outputs when processing signals from both detectors and manual call points.

Annex F; covers the recognition and processes when dealing with faults.

Annex G; explains the requirements for the interfacing of the input/output equipment such as fire brigade panels.

Annex H; refers to the integrity of transmission paths to limit the effects caused by faults.

Annex I is specific to control and indication equipment which requires software.

Annex ZA; deals with the clauses of the standard in respect of their compliance with the mandate of the EU construction products regulation.

part 3 fire alarm devices - sounders

Introduction

This standard covers the requirements for the construction and performance of sounders and their performance under climatic, mechanical and electrical interference conditions. Sounders are classified as indoor (A) and outdoor (B). In fire detection and fire alarm systems, voice sounders are also used for warning the occupants of a building of the outbreak of fire, using a combination of signal and voice message(s). The requirements, test methods and performance criteria specified in this standard for sounders are also applicable to voice sounders. Additional requirements specific to voice sounders are incorporated in Annex C.

Requirements

The sounder may produce different sound levels under different conditions, e.g., when operating on different voltage ranges or with different sound patterns. When appropriate the sound level of each unit may be measured for each sound pattern when tested. Alternatively the sounder will be tested using an output deemed to consume max current and produce the maximum sound output. The sounder shall produce A-weighted sound levels of at least 65 dB in one di-

rection and not exceeding 120 dB in any direction.

(A-weighted sound level sound pressure expressed in dB, characteristics are given in IEC 60651).

Sounders can produce different frequencies and sound patterns and, therefore, this standard does not specify a minimum and maximum for either. These may also vary from country to country; therefore local standards need to be consulted. Access to the device shall be restricted by the use of special screws or tools and it should not be possible to change the manufacturer's settings without use of the same or by breaking a seal.

If on site adjustment of the device settings is provided, then the factory setting, which complies with this standard, should be clearly displayed for each and should only be accessible to change with a password or special tool.

Sounders shall be rated for a minimum of 100 hours which will not affect their ability to cycle on and off as required as part of the compliance testing. This requirement does not apply to the capacity of any integral batteries used as a means of providing local standby power. The capa-

fire alarm devices - sounders

city and charging requirements of such batteries should meet the requirement of the system.. The degree of protection provided by the enclosure of fire alarm sounders shall be in accordance with EN60529, IP21 for type A and IP33 for type B. The attached labelling, will provide, reference to this standard, type A or B.

Voice Sounders are audible devices for generating and broadcasting recorded voice messages. The voice sounder shall meet all of the requirements applicable to audible fire alarm devices. To prevent acoustic interaction between adjacent voice sounders the provision for synchronising the alert signal and message sequence with that of other devices of the same type may be necessary. In this case, the requirements of the test described in appendix C shall be met.

Tests, are carried out to prove the sound levels specified by the manufacturer are achievable within the specified voltage range and do not deviate by more than 6dB for each direction. The maximum sound level must provide an output greater than 65dB (A) in at least one direction, and not exceed 120dB (A) in any direction, at 1 metre. Sound levels are required to be at the specified level for each of the angles specified by the manufacturer, through a semi-circular arc in front of the device).

fire alarm devices - sounders

Table 1 – Schedule of tests

Test	Subclause
Reproducibility	5.2
Operational performance	5.3
Durability	5.4
Dry heat (operational)	5.5
Dry heat (endurance)	5.6
Cold (operational)	5.7
Damp heat, cyclic (operational)	5.8
Damp heat, steady state (endurance)	5.9
Damp heat, cyclic (endurance)	5.10
SO ₂ corrosion (endurance)	5.11
Shock (operational)	5.12
Impact (operational)	5.13
Vibration (operational)	5.14
Vibration (endurance)	5.15

fire alarm devices - sounders

Table 1 – Schedule of tests

Test	Subclause
Electrostatic discharge (operational)	5.16
Radiated electromagnetic fields (operational)	5.16
Conducted disturbances induced by electromagnetic fields (operational)	5.16
Voltage transients, fast transient bursts (operational)	5.16
Voltage transients, slow high energy voltage surge (operational)	5.16
Enclosure protection	5.17

1) Where after one of the test specified in 5.5 to 5.16 the A-weighted sound level of the specimen being tested differs from that measured during the reproducibility test by more than 6 dB, a new specimen shall be used for the next test on the schedule for that specimen. The sound level shall be first measured as specified in 5.2.

2) The EMC tests specified in 5.16 are not required for sounders which do not rely on active electronic components for their operation.

3) The tests on an individual specimen may be carried out in any order except that the reproducibility test (5.2) shall be performed first on all specimens and the tests on specimens 1 and 2 shall be carried out in the order listed (i.e. 5.17 last).

section two | an introduction to the suite of EN54 standards

fire alarm devices - sounders

Annexes to EN54-3

Annex A- Sound level test

Annex B- Comparative sound test

Annex C- Voice Sounders

Annex ZA; deals with the clauses of the standard in respect of their compliance with the mandate of the EU construction products regulation.

part 4 power supply equipment

Introduction

This standard covers the requirements, test procedures and performance of power supplies used with fire alarm and detection systems in buildings, both internal and external to the control and indicating equipment.

General requirements

The requirements for meeting this standard are detailed in clauses 4-8 and testing is as detailed in clause 9 of this standard. The power supply unit will operate from an incoming mains supply and incorporate at least one rechargeable standby battery. The unit will be capable of maintaining a fully charged battery. Each source of power shall be capable of supplying the specified output or for an integral power supply, the equipment into which it is integrated.

The incoming mains supply should be solely for the fire detection and alarm system and its standby batteries. The battery should automatically supply the system in the event of an incoming power failure and revert to standby when the supply is restored. Failure of an integrated power supply incoming mains shall be transparent other than to operate any power war-

ning indicators. Any known interruptions during changeover of power source shall be detailed by the manufacturer. Failure of one power source shall not render the unit inoperative such that no power is delivered to the system.

Functionality

The power supply shall be capable of delivering full power to the system irrespective of the standby battery condition, including when recharging a discharged standby battery. The standby battery charging current can be reduced when the power supply is required to supply maximum current to the system. The standby battery should also be capable of supplying the systems demands when the incoming mains supply is disconnected. The power supply shall be fully monitored, including incoming mains, battery supply, and battery high resistance. The power supply shall signal a fault condition within 30 minutes of the fault occurrence. If the power supply unit is an integral part of the control and indicating equipment such faults shall be signalled in accordance with EN54-2.

The design, electrical and mechanical, shall be in accordance with section 6 of the standard. If the power supply is de-

power supply equipment

signed for use with the control and indicating equipment but external to, then duplicate connections should be made ensuring that a single short circuit cannot result in a loss of power.

The standby battery will be suitably labelled indicating its age and type and if integral to other components of the fire alarm and detection system, shall be of the sealed type. The batteries output voltage should be monitored and outputs turned off if that voltage falls below the specified level.

The battery charger will charge the battery automatically and when discharged to its final voltage be recharged to 80% of its capacity within 48 hours. The charger shall be designed and operate within the battery manufacturers temperature limits. Other than for monitoring purposes the battery shall not discharge through the charger, when a potential difference exists.

If required to operate during the testing the power supply equipment shall be connected to both mains and a suitable battery. The output shall be connected to suitable cable and tested under a full load. Fully functional tests are as detailed in section 9 and carried out in accordance with table 1. However the procedu-

re and requirements do vary between integrating and non-integrating power supply equipment.

section two | an introduction to the suite of EN54 standards

power supply equipment

Table 1-Functional tests

Test	Mains supply voltage	Condition of battery	Loading condition	Duration of test
1	$V_n + 10\%$	Discharged ^b	$I_{max. a}$	4 h
2	$V_n - 15\%$	Discharged ^b	$I_{max. a}$	4 h
3	$V_n - 15\%$	Discharged ^b	$I_{max. b}$	Manufacturer's specification with a minimum of 5 min
4	Disconnected	Discharging ^c	$I_{max. b}$	
5	$V_n - 15\%$	Replaced by short circuit ^d	$I_{max. a}$	
6	$V_n - 15\%$	Replaced by short circuit ^e	$I_{max. a}$	
7	$V_n + 10\%$	Disconnected	$I_{max. b}$	
8	$V_n - 15\%$	Disconnected	$I_{max. b}$	
9	$V_n + 10\%$	Fully charged ^f	I_{min}	

^a V_n is nominal voltage of the public electricity supply or equivalent.

^b A battery of max specified capacity discharged to its final voltage as described in 9.3.1.1. The battery is allowed to charge during the test.

^c In this test the battery may be replaced by a laboratory power supply capable of supplying the required output current. The output voltage of the power supply shall be gradually reduced from the fully charged voltage of the battery to the voltage at which the PSE output(s) switch off as in 5.2.3.

^d Mains shall be applied after having replaced the battery by a short circuit.

^e Replace the battery by a short circuit after the mains is applied.

^f A battery charged to its fully charged voltage

power supply equipment

Environmental tests are carried out in accordance with table 2 below. If the power supply unit is housed within other equipment for which there is a different standard, then testing in accordance with that standard shall apply. (e.g. EN54-2).

However functional tests, required by this standard, to be undertaken after environmental testing, shall also take place. If the power supply is housed separately or in an enclosure for which there is no standard then table 2 shall apply.

Table 2 – Environmental tests

Test	Operational or endurance	Clause number
Cold	Operational	9.5
Damp heat, steady state	Operational	9.6
Impact	Operational	9.7
Vibration, sinusoidal	Operational	9.8
Electromagnetic compatibility (EMC) immunity tests	Operational	9.9
Damp heat, steady state	Endurance	9.14
Vibration, sinusoidal	Endurance	9.15

section two | an introduction to the suite of EN54 standards

power supply equipment

Annexes to EN54-4

Annex A- Laboratory procedure for testing compliance with the requirements of 5.2.1 and 5.4.c

Annex ZA- Deals with the clauses of the standard in respect of their compliance with the mandate of the EU construction products regulation.

part 5 heat detectors - point detectors

Scope

This standard specifies the requirements for point type heat detectors. Typical application temperature is the temperature of the environment into which the detector is placed and which exists for most of the time in a none fire situation as detailed in table 1. Maximum application temperature is that which the detector may be subjected to for short periods of time, in a non-fire situation as detailed in table 1.

Static response temperature is that at which the detector would be in an alarm state if subjected to a vanishingly small rate of rise temperature, typically 0.2K min⁻¹

Classification

Detectors shall conform to one or more of the following classes, as shown in the attached table, column 1, according to the requirements of the detailed tests.

Table 1 Detector Classification temperatures

Detector Class	Typical Application Temperature °C	Maximum Application Temperature °C	Minimum Static Response Temperature °C	Maximum Static Response Temperature °C
A1	25	50	54	65
A2	25	50	54	70
B	40	65	69	85
C	55	80	84	100
D	70	95	99	115
E	85	110	114	130
F	100	125	129	145
G	115	140	144	160

heat detectors - point detectors

Manufacturers may add the suffix S, (Static) or R, (Rate of Rise) to the detector data. Detectors which provide only a static response do not respond below their minimum response temperature irrespective of the rate of rise in temperature. Detectors incorporating a rate of rise characteristic will meet the response requirements shown in table 4, even when installed where temperatures are significantly lower than the typical application temperature.

Individual alarm indication shall be provided for class A1, A2, B, C or D detectors via a red visual indicator which shall be extinguished when the detector is reset. Where conditions other than fire are indicated these shall be clearly distinguishable other than when the detector is in service mode. For detachable detectors the indicator may be in the head or the base and should be visible at a distance of 6 metres directly below the detector in ambient light levels of up to 500 lux.

Classes E, F or G detectors shall contain either an integral red indicator or some other means of indicating its alarm state.

Monitoring of detachable detectors shall be provided by which removal of the

detector from its base without some form of indication is not possible.

The manufacturer's settings should not be accessible to change without the need for a password, special tool or by the breaking or removal of a seal. If on site adjustment of the detectors response type is provided, then the factory setting, which complies with this standard, should be clearly displayed for each detector and should only be accessible to change with a password or special tool or by the removal of the detector from its base.

Any settings which are not compliant with this standard shall only be accessible by the same means and it should be clearly displayed, either on the detector or in data format, the detector does not comply with this standard. The adjustments may be carried out either at the detector or via the control and indicator equipment.

Configuration data relevant to the compliance with a standard shall be stored in non-volatile memory and access shall be password protected or by use of a special tool and shall only be possible when the device is taken out of normal service.

heat detectors - point detectors

Detectors are subjected to the following Test Schedules.

Directional dependence: to prove that performance is not dependent upon a specific airflow

Static response temperature: to confirm the detectors response to a slow rate of rise in temperature. Static type detectors may also be subjected to further testing to ensure they do not respond below their stated response temperature relative to their class.

Response times from typical application temperature: to prove the detectors response, (table 1) to a range of rate of rise air temperatures. The response times should lie between the upper and lower levels shown in table 4, relative to its class.

Variation in supply parameters: to prove that within the detectors specified voltage range the response times are reasonably constant

Reproducibility: to show that response times are within the specified limits and for resettable detectors that the response times do not vary significantly during repeat testing. Response times shall be

as detailed in table 4, between the upper and lower levels.

Cold (operational): to prove the detector operates correctly in low temperature environments. The detectors, (resettable) response when subjected to a rise in temperature of 3 Kmin⁻¹ shall not be less than 7min 13s. At a temperature rise of 20 Kmin⁻¹ the response time shall not be less than 30s for Class A1 and 1min for other classes. For non-resettable detectors the response times shall be those shown in table 4, between the upper and lower times for the relevant class.

Dry heat (endurance): proves the performance of detectors in classes C, D, E, F and G when installed in high ambient temperatures. The tests are at temperatures indicated in table 1. The detectors, (resettable) response when subjected to a rise in temperature of 3 Kmin⁻¹ shall not be less than 7min 13s. At a temperature rise of 20 Kmin⁻¹ the response time shall not be less than 1min. For non-resettable detectors the response times shall be those shown in table 4.

Damp heat, cyclic and steady: These tests prove the detectors ability to exist in humid conditions and where there

heat detectors - point detectors

may be condensation present, for short and long durations. The detectors shall remain fault free and their response (for resettable) when subjected to a rise in temperature of 3 Kmin-1 will not be less than 7min 13s. At a temperature rise of 20 Kmin-1 the response time shall not be less than 30s for Class A1 and 1min for other classes. For non- resettable detectors the response times shall be those shown in table 4

Corrosion (SO₂) will demonstrate the detectors resistance to corrosive atmospheres. The detector should remain fault free and respond, (resettable) to a rise in temperature of 3 Kmin-1 within 7min 13s. At 20 Kmin-1 the response time shall not be less than 30s for Class A1 and 1min for other classes. For non- resettable detectors the response times shall be those shown in table 4,

Shock, Impact and Vibration: these tests are designed to prove the detectors immunity to mechanical shocks, impact and short and long term vibration. The shock test procedure is that described in the IEC document 60068-2-27. long term vibration tests are conducted in accordance with IEC document 60068-2-6. The detector should remain fault free and respond, (resettable) to a rise in tempe-

perature of 3 Kmin-1 within 7min 13s. At 20 Kmin-1 the response time shall not be less than 30s for Class A1 and 1min for other classes. For non- resettable detectors the response times shall be those shown in table 4,

Electromagnetic compatibility (EMC): tests are carried out in accordance with EN50130-4. The detector should respond, (resettable) to a rise in temperature of 3 Kmin-1 within 7min 13s. At 20 Kmin-1 the response time shall not be less than 30s for Class A1 and 1min for other classes. For non- resettable detectors the response times shall be those shown in table 4.

heat detectors - point detectors

Table 4 Response time limits

Rate of rise of air temperature	Class A1 detectors			
	Lower limit of response time		Upper limit of response time	
K min ⁻¹	Min	S	Min	S
1	29	0	40	20
3	7	13	13	40
5	4	9	8	20
10	1	0	4	20
20		30	2	20
30		20	1	40

heat detectors - point detectors

Table 4 Response time limits

Rate of rise of air temperature	Class A2, B, C, D, E, F and G detectors			
	Lower limit of response time		Upper limit of response time	
K min ⁻¹	Min	S	Min	S
1	29	0	46	0
3	7	13	16	0
5	4	9	10	0
10	2	0	5	30
20	1	0	3	13
30		40	2	25

Response times from high ambient temperature: proves the detectors ability to perform correctly in a high temperature environment. The detectors response time should fall between those indicated below in table 5.

heat detectors - point detectors

Table 5 Response time limits for maximum application temperature

Detector class	Lower limit of response time at air temperature rise of			
	3K min-1		20K min-1	
	Min	S	Min	S
A1	1	20		12
All other	1	20		12

Detector class	Upper limit of response time at air temperature rise of			
	3K min-1		20K min-1	
	Min	S	Min	S
A1	13	40	2	20
All other	16	0	3	13

Annexes to EN54-5

Annex A - Heat tunnel for response time and response temperature measurements

Annex B - Information concerning the construction of the heat tunnel

Annex C - Derivation of upper and lower limits of response times

Annex D - Apparatus for impact test

Annex ZA - Clauses of this European Standard addressing essential requirements or other provisions of EU construction products regulation.

part 7 smoke detectors

Scope, the standard specifies the requirements, test methods and performance criteria for point type smoke detectors, both optical and ionisation, including smoke detectors with more than one sensor. Ionisation detectors are not permitted in certain countries therefore local codes should be consulted.

Requirements

Compliance, for the detector to meet the requirements of this clause shall be verified by visual inspection or engineering assessment, tested as described in clause 5 and, for detectors with more than one smoke sensor, shall meet the requirements of the tests detailed in Annex N.

Individual alarm indication shall be provided via a red visual indicator which shall be extinguished when the detector is reset. Where conditions other than fire are indicated these shall be clearly distinguishable other than when the detector is in service mode. For detachable detectors the indicator may

be in the head or the base and should be visible at a distance of 6 metres directly below the detector in ambient light levels of up to 500 lux. Where there is a connection to remote indicators, control relays etc., failures of these connections shall not prevent the correct operation of the detector.

Monitoring of detachable detectors shall be provided by which removal of the detector from its base without some form of indication is not possible.

The manufacturer's settings should not be accessible to change without the need for a password, special tool or by the breaking or removal of a seal.

If on site adjustment of the detectors response type is provided, then the factory setting, which complies with this standard, should be clearly displayed for each detector and should only be accessible to change with a password or special tool or by the removal of the detector from its base.

Any settings which are not compliant

smoke detectors

with this standard shall only be accessible by the same means and it should be clearly displayed, either on the detector or in data format, the detector does not comply with this standard. The adjustments may be carried out either at the detector or via the control and indicator equipment.

The detector shall be designed to restrict the access of insects into its sensitive parts without restricting smoke entry. In order to achieve this it may be necessary to take other precautions against false alarms due to the entry of small insects.

The provision of “drift compensation” to counter the effects of a build-up of dirt in the detector shall not significantly reduce the detector’s sensitivity to slowly developing fires. To verify this, an assessment of the detector’s response to slow increases in smoke density shall be made. The detector shall meet the requirements of clause 4.8 if its response times falls within those specified.

Testing a detectors response with very slow increases in smoke density is impractical and therefore assessment is made of the detectors response by a combination of test and simulations together with analysis of the software. The detectors performance is measured against formulae designed to confirm a response within 100 seconds when the increase in smoke density is greater than one fourth of the detector threshold value multiplied by 1.6. This ensures the detectors response value does not increase by more than a factor of 1.6 before an alarm condition is reached. A detectors response should fall between a maximum sensitivity of 1.5% and a minimum of 6% obscuration per metre when tested.

section two | an introduction to the suite of EN54 standards

smoke detectors

Test schedule

Test	Clause
Repeatability	5.2
Directional dependence	5.3
Reproducibility	5.4
Variation in supply parameters	5.5
Air movement	5.6
Dazzling ¹⁾	5.7
Dry heat (operational)	5.8
Cold (operational)	5.9
Damp heat, steady state (operational)	5.10
Damp heat, steady state (endurance)	5.11
Sulphur dioxide (SO ₂) corrosion (endurance)	5.12
Shock (operational)	5.13
Impact (operational)	5.14

smoke detectors

Test schedule

Test	Clause
Vibration, sinusoidal (operational)	5.15
Vibration, sinusoidal (endurance)	5.16
Electrostatic discharge (operational)	5.17
Radiated electromagnetic fields (operational)	5.17
Conducted disturbances induced by electromagnetic fields (operational)	5.17
Fast transient bursts (operational)	5.17
Slow high energy voltage surge (operational)	5.18
Fire sensitivity	
1) This test only applies to detectors using scattered or transmitted light.	

smoke detectors

Annexes to EN54-7

Annex A - Smoke tunnel for response threshold value measurements

Annex B - Test aerosol for response threshold value measurements

Annex C - Smoke measuring instruments

Annex D - Apparatus for dazzling test

Annex E - Apparatus for impact test

Annex F - Fire test room

Annex G -Smouldering (pyrolysis) wood fire (TF2)

Annex H -Glowing smouldering cotton fire (TF3)

Annex I - Flaming plastics (polyurethane) fire (TF4)

Annex J - Flaming liquid (n-heptane) fire (TF5)

Annex K - Information concerning the construction of the smoke tunnel

Annex L - Information concerning the requirements for the response to slowly developing fires

Annex M - Information concerning the construction of the measuring ionization Chamber

Annex N - Additional requirements and test methods for smoke detectors with more than one smoke sensor

Annex ZA - deals with the clauses of the standard in respect of their compliance with the mandate of the EU construction products regulation.

part 10 flame detectors

Scope This European Standard specifies the requirements, test methods and performance criteria for point-type, resettable flame detectors that operate using radiation from a flame for use in fire detection systems.

Requirements

Compliance is for the detector to be verified by visual inspection or engineering assessment and successfully tested as described in clause 5. Detectors will be classified, when responding to fires within 30 secs as: Class 1, up to 25metres, Class 2 up to 17 metres or Class 3, up to 12 metres. Below 12metres detectors will not be classified.

Individual alarm indication shall be provided via a red visual indicator which shall be extinguished when the detector is reset. Where conditions other than fire are indicated these shall be clearly distinguishable other than when the detector is in service mode. For detachable detectors the indicator may be in the head or the base. Where there is a connection to remote indica-

tors, control relays etc., failures of these connections shall not prevent the correct operation of the detector.

Monitoring of detachable detectors shall be provided by which removal of the detector from its base without some form of indication is not possible.

The manufacturer's settings should not be accessible to change without the need for a password, special tool or by the breaking or removal of a seal and for each setting. For those settings which the manufacturer claims compliance with this standard, each shall have achieved a classification corresponding to that marked on the detector for that setting;

If on site adjustment of the detectors response type is provided, then the factory setting, which complies with this standard, should be clearly displayed for each detector and should only be accessible to change with a password or special tool or by the removal of the detector from its base.

flame detectors

Any settings which are not compliant with this standard shall only be accessible by the same means and it should be clearly displayed, either on the detector or in data format, the detector does not comply with this standard. The adjustments may be carried out either at the detector or via the control and indicator equipment.

Technical data regarding both installation and maintenance should be provided with each detector or in the case of supporting documentation, document references should be provided. If on site adjustment of the detectors response type is provided, the data shall clearly indicate the classification, means of adjustment or programming instructions.

For detectors which are software control controlled then the documentation, design, and storage of programs and data will meet the requirements of 4.9.2, 4.9.3 and 4.9.4.

The Principle of testing is to measure the response point when exposing the

detector to radiation from a suitable flame source and establishing the maximum distance at which the detector will reliably enter the alarm condition within a time of 30 s. The test apparatus shall be as described in annex A, B and C. When testing, the radiation source is modulated in accordance with the manufacturer's specification. Tests are conducted using methane, n-heptane, and methylated spirit.

flame detectors

Table 1 – Test Schedule

Test	Clause
Reproducibility	5.2
Repeatability	5.3
Directional dependence	5.4
Fire sensitivity	5.5
Dazzling (operational)	5.6
Dry heat (operational)	5.7
Cold (operational)	5.8
Damp heat cyclic (operational)	5.9
Damp heat steady state (endurance)	5.10
Sulphur dioxide (SO ₂) corrosion (endurance)	5.11
Shock (operational)	5.12
Impact (operational)	5.13
Vibration, sinusoidal (operational)	5.14
Vibration, sinusoidal (endurance)	5.15

section two | an introduction to the suite of EN54 standards

flame detectors

Table 1 – Test Schedule

Test	Clause
Variation in supply parameters (operational)	5.16
Electrostatic discharge (operational)	5.17
Radiated electromagnetic fields (operational)	5.17
Conducted disturbances induced by electromagnetic fields (operational)	5.17
Fast transient bursts (operational)	5.17
Slow high energy voltage surge (operational)	5.17

Annexes to EN54-10

Annex A - Optical Bench Response test

Annex B - Methane Burner

Annex C - Test Fires

Annex D - Dazzle test

Annex E - Impact test apparatus

Annex ZA - deals with the clauses of the standard in respect of their compliance with the mandate of the EU construction products regulation.

part 1 1 manual call points

Scope

This standard specifies the requirements and methods of test for both indoor and outdoor manual call points and includes the appearance and operation for both types A (single action) and B (dual action). It covers simple devices, those fitted with electronic components (e.g. resistors, diodes) and addressable units. This Standard does not cover manual call points for use as intrinsically safe or for in hazardous conditions, where such applications require further requirements or tests. The Colours of various parts of the call point shall be in accordance with 4.7.2.3

Compliance is for the manual call point which shall be verified by visual inspection or engineering assessment and successfully tested as described in clause 5.

Requirements

Each manual call point should be clearly labelled providing information regarding the relevant standard, type,

and whether indoor or outdoor version. The normal condition of the call point shall be recognizable by the appearance of the operating face as detailed in 4.7. which shall be flat and shall not be broken, deformed or displaced?

Change from the normal to the alarm condition, will be by the following methods

For type A manual call points, breaking and/or displacing the frangible element together with changing the appearance of the operating face.

For type B manual call points: as above plus manually activating the operating element.

It shall be possible to see that the operating element is in the activated position but not possible to activate it without breaking or displacing the frangible element [see 4.3.2 b)] or without the use of a special tool (see 4.6).

A transparent flap may be fitted over the call point to protect against accidental operation of a type A call point.

manual call points

If Individual alarm indication is provided it shall be positioned on the front of the call point, be red and shall be extinguished when the call point is reset. It shall be visible from a distance of 2 m directly in front of the manual call point in an ambient light intensity up to 500 lx. Where conditions other than fire are indicated these shall be clearly distinguishable other than when the call point is in service mode. The call point shall be marked with the appropriate symbols as detailed in paragraph 4.7.3.

The manual call point shall be reset after operation as follows:

- a) for non-resettable frangible elements, by inserting a new element;
- b) for resettable frangible elements, by resetting the frangible element.

Furthermore for type B manual call points, it shall only be possible to return it to its normal condition by means of a special tool.

The manual call point shall incorporate a test facility, which will require a spe-

cial tool to simulate an alarm condition by activating the operating element, allowing the manual call point to be reset without breaking the frangible element. Operating the frangible element shall not cause injury to the operator.

For type B manual call points the actuation force of the operating element shall meet the requirements of EN 894-3:2000.

For manual call points which are software control controlled then the documentation, design, and storage of programs and data will meet the requirements of 4.8.2, 4.8.3 and 4.8.4.

The alarm signal shall respond to the required test, indicated at the supply and monitoring equipment (see 5.1.2) within 10 s after the operating element has been activated.

manual call points

Table 2 – Test Schedule

Test	Clause number
Variation of supply parameters	5.6
Dry heat (operational)	5.7
Dry heat (endurance)	5.8
Cold (operational)	5.9
Damp heat, cyclic (operational)	5.10
Damp heat, cyclic (endurance)	5.11
Damp heat, steady state (endurance)	5.12
SO ₂ corrosion (endurance)	5.13
Shock (operational)	5.14
Impact (operational)	5.15
Vibration (operational)	5.16
Vibration (endurance)	5,17

section two | an introduction to the suite of EN54 standards

manual call points

Table 2 – Test Schedule

Test	Clause number
Electromagnetic compatibility (operational) ^{a)} ; i.e. a) electrostatic discharge b) radiated electromagnetic fields c) conducted disturbances induced by electromagnetic fields d) voltage transient, fast transient bursts e) voltage transient, slow high-energy voltage surge	5.18
Enclosure protection	5.19
^{a)} Test only for manual call points with active electronic components.	

manual call points

Table 2 – Test Schedule

Test	Indoor use	Outdoor use
Variation of supply parameters	x	x
Dry heat (operational)	x	x
Dry heat (endurance)		x
Cold (operational)	x	x
Damp heat, cyclic (operational)	x	x
Damp heat, cyclic (endurance)		x
Damp heat, steady state (endurance)	x	x
SO ₂ corrosion (endurance)	x	x
Shock (operational)	x	x
Impact (operational)	x	x
Vibration (operational)	x	x
Vibration (endurance)	x	x

section two | an introduction to the suite of EN54 standards

manual call points

Table 2 – Test Schedule

Test	Indoor use	Outdoor use
Electromagnetic compatibility (operational) _a ; i.e. a) electrostatic discharge b) radiated electromagnetic fields c) conducted disturbances induced by electromagnetic fields d) voltage transient, fast transient bursts e) voltage transient, slow high-energy voltage surge	x	x
Enclosure protection		x

Annexes to EN54-11

Annex A- Test apparatus

(for operation)

Annex B - Test apparatus

(for non-operation)

Annex C- Test apparatus for

impact test

Annex ZA - deals with the clauses of the standard in respect of their compliance with the mandate of the EU construction products regulation.

part 12 smoke detectors - line type

Scope

This European Standard specifies requirements, test methods and performance criteria for line type smoke detectors utilising the attenuation of an optical beam, for use in fire detection systems. The detector will consist of a transmitter and a receiver and may include reflector(s).

Requirements

Compliance, for the detector to meet the requirements of this clause, shall be verified by visual inspection or engineering assessment and successfully tested as described in clause 5.

Individual alarm indication shall be provided via a red visual indicator which shall be extinguished when the detector is reset.

The manufacturer's settings should not be accessible to change without the need for a password, special tool or by the breaking or removal of a seal.

If on site adjustment of the detectors response type is provided, then the factory setting, which complies with this standard, should be clearly displayed for each detector and should only be accessible to change with a password or special tool or by the removal of the detector from its base.

Any settings which are not compliant with this standard shall only be accessible by the same means and it should be clearly displayed, either on the detector or in data format, the detector does not comply with this standard. The adjustments may be carried out either at the detector or via the control and indicator equipment.

Monitoring of detachable detectors shall be provided by which removal of the detector from its base without some form of indication is not possible.

A fire alarm signal shall have priority over faults resulting from a rapid change in obscuration or by a result of the limit of compensation being reached.

smoke detectors - line type

Configuration data relevant to the compliance with a standard shall be stored in non-volatile memory and access shall be password protected or by use of a special tool and shall only be possible when the device is taken out of normal service.

The detectors shall be tested in accordance with the test schedule in Table 1 and include the following test which are applicable to (linear) beam) type smoke detectors.

Directional dependence, whereby the detector is tested to show that small inaccuracies in alignment do not affect its performance.

Slow changes in attenuation whereby the detector is tested to ensure that it can detect a slowly smouldering fire despite any sensitivity compensation applied to counter the effects of contamination of the optical components.

Optical path length dependence, whereby the detector is tested to show that the response threshold does not

change significantly over the stated minimum and maximum optical path length.

Tests are conducted ensuring its sensitivity to a broad spectrum of fires likely to be encountered in various types of buildings and applications.

smoke detectors - line type

Table 1 – Test Schedule

Test	Clause
Reproducibility	5.2
Repeatability	5.3
Directional dependence	5.4
Variation of supply parameters	5.5
Rapid changes in obscuration	5.6
Slow changes in obscuration	5.7
Optical path length dependence	5.8
Fire sensitivity	5.9
Stray light	5.10
Dry heat (operational)	5.11
Cold (operational)	5.12
Damp heat, steady state (operational)	5.13
Damp heat, steady state (endurance)	5.14
Vibration (endurance)	5.15

section two | an introduction to the suite of EN54 standards

smoke detectors - line type

Table 1 – Test Schedule

Test	Clause
Electrostatic discharge (operational)	5.16
Radiated electromagnetic fields (operational)	5.16
Conducted disturbances induced by electromagnetic fields (operational)	5.16
Fast transient bursts (operational)	5.16
Slow high energy voltage surges (operational)	5.16
Sulphur dioxide SO2 corrosion (endurance)	5.17
Impact (operational)	5.18

Annexes to EN54-12

Annex A - Smoke test for response threshold value measurements

Annex B – Fire test room

Annex C – Smouldering pyrolysis wood fire TF2

Annex D – Glowing Smouldering Cotton TF3

Annex E – Flaming Plastic (polyurethane) fire TF4

Annex F – Flaming liquid (n-heptane) fire TF5

Annex G – Stray light test set up

Annex H - Glowing smouldering cotton fire (TF3)

Annex ZA - deals with the clauses of the standard in respect of their compliance with the mandate of the EU construction products regulation.

part 13 compatibility assessment of system components

Scope

This document specifies the requirements for the compatibility and connectability of system components that comply with the requirements of EN 54 or with their specification in the absence of an EN 54 standard and includes system requirements only when these are necessary for compatibility assessment. It also specifies requirements for the integrity of the fire detection and fire alarm system when connected to other systems.

Requirements

Compliance with this standard requires the system design and compatibility of its components to meet the requirements of this clause. This shall be verified by assessment (5.1) with regard to the documentation (4.7), and shall be successfully tested (if necessary) as described in 5.2 to 5.5. System requirements can also be stated in national application guidelines /codes of practice. Suppliers of components must ensure that they meet the requirements

of this document and the relevant part of EN 54 and also the requirements of the application guidelines of the countries where the components are intended to be used.

Networked systems

A fault in a single fire alarm control panel shall not affect other control units. A single fault on a transmission path connecting control panels shall not adversely affect the functionality of the network. Where more than a single fault results in control panels being disconnected it shall be clearly displayed which panels are affected. All faults shall be indicated. Where there is justification, e.g. a high life risk the standard suggests that at each control panel there be a facility to communicate with the fire brigade, should 2 simultaneous transmission faults occur, disconnecting a panel from the network and the main control panel.

A fire alarm condition shall be indicated on the main control panel within 20 s and a fault within 120s.

compatibility assessment of system components

The means provided for minimizing the effect of a fault on a transmission path shall complete the restoration within 300 s. The main control panel shall at least indicate general conditions as defined in EN 54-2.

At the main control panel it shall be possible to identify the panel from which the signal originated.

At the main panel, it may be possible to operate controls which are found on the individual panels, but only with the same affects. Any software that is used for networking shall conform to EN 54-2:1997, Clause 13.

Compatibility can be achieved if essential components (type 1) operate within the specified limits in the relevant part of EN54, whereas essential components not covered by an EN54 standard shall conform to EN54-1, clause 4 and meet the EMC immunity requirements of EN50130-4. For a non-essential component (type 2), such as a printer, to be connected, then

such a device must in no way jeopardise the operation of the system.

Input and output devices for connection to a fire protection system are considered as type 1.

Assessment methods and tests

A theoretical analysis to assess the compatibility of components when interconnected will take place and the outcome will indicate whether a physical test is required. (Annex C provides an example). EMC testing will be carried out if thought necessary.

Functional test for compatibility

This test is to prove compliance of components in a specified configuration provided by the manufacturer and in accordance with the relevant EN54 part.

section two | an introduction to the suite of EN54 standards

compatibility assessment of system components

Annexes to EN54-13

Annex A - Function of a Fire Detection and Alarm System

Annex B – Classification of component types 1 and 2

Annex C – Example methodology for theoretical assessment

part 16 voice alarm control and indicating equipment

Introduction

This standard covers the requirements for the construction and performance for voice alarm control and indicating equipment for use in fire detection and fire alarm systems where the audible signal is in the form of tone(s) and/or voice message(s). Those parts of the system concerning audibility and intelligibility, are not covered in this standard. Consideration should be given to the requirements of an overall system that may affect the design and which may be specified in another part of EN 54, in national legislation, codes and standards or in contractual documents.

Requirements

A voice alarm system, when forming part of the fire detection and fire alarm system provides an audible fire alarm signal. Such a system will require voice alarm control and indication in order to react to an incoming alarm and subsequently generate and broadcast a message. The two systems may share an integrated form of control or be separate.

This standard being similar in structure to part 2 stipulates those functions that are mandatory, as well as those which are optional. As in part 2 the optional functions may be specific to certain applications

When the systems are truly integrated they may share common indications, manual controls and outputs (see Annex F); however a single fault affecting the control and indicator panel shall not affect the mandatory functions of the voice alarm system. The indications and manual control(s) of the voice alarm condition shall be clearly identifiable.

The system power supply equipment may be common to both systems but must comply with the requirements of EN 54-4.

The voice alarm control and indicator shall be capable of clearly displaying the following, a quiescent condition; voice alarm condition; fault warning condition and a disablement condition .The control shall be capable of displa

voice alarm control and indicating equipment

ying, on different alarm zones at the same time, a voice alarm condition; fault warning condition and a disablement condition.

Where specified, all mandatory indications shall be clearly identified and where alpha numeric displays provide additional information for different functional conditions these may be displayed at the same time. Information should be grouped and separated for each condition. A separate power on indicator shall be provided on each enclosure, where they exist. Where further indication is provided it shall be distinguishable and not override the primary indicators. A system normal display may be provided but must not conflict with the above. The voice alarm control shall be capable of receiving and processing alarm signals and generating the appropriate voice alarm outputs within 3s or on the expiry of any delay period.

Annex E provides additional information concerning the interface between the voice alarm and the fire alarm con-

trollers. The voice alarm control shall provide a fault warning within 100 s of the occurrence of a fault, unless specified differently in this European Standard or in other parts of EN 54. The voice alarm control may have provision for at least one spare power amplifier which should replace the faulty equipment within 10 secs of the fault being detected. The spare should be supervised when not in use.

A common fault warning shall be provided if there is a condition relating to any short circuit or interruption in a voice alarm transmission path, including the microphone and loudspeakers, even where the fault does not affect the operation of loudspeakers; and to any fire alarm devices when used, and the failure of any power amplifier.

The mandatory indications and/or outputs shall not be corrupted by multiple alarm signals when received simultaneously, either automatically or manually. Where the voice and fire alarm systems are separate, failure of the transmission path between the two

voice alarm control and indicating equipment

shall not result in any loss of control or change of state of the voice alarm, without indication being provided.

The audible alarm (message) may be delayed, up to a maximum of 10 minutes but may be over-ridden manually. Delays can be turned on/off manually or automatically, with the applicable level of access and a separate and discreet indicator or display shall be visible when an alarm occurs when the delay is turned on. The display will be cancelled when the alarm message is broadcast. The system can be configured for phased warning broadcasts, which can be switched on and off with the applicable level of access.

Where the voice alarm condition has been triggered from the fire alarm control, the message broadcast may be silenced and reset from the same control panel; incomplete messages will be completed before being silenced. The silence function should be reversible and messages rebroadcast when required. Any parts of the system which

remain in alarm after rest shall be redisplayed within 20 secs.

In addition to the voice alarm outputs the control may have provision for the automatic transmission of fire signals to other devices such as beacons and tactile devices. It shall be possible to deactivate and reactivate these with the appropriate level of access, but not automatically.

The alarm broadcast may be manually activated, zone by zone, or in groups of zones with the appropriate access level. Manual activation will activate all mandatory inputs and outputs. Indication that a voice alarm condition exits in each zone shall be provided and may be via a led and/or LCD display. Fault and disablement conditions can be displayed in similar fashion.

The voice alarm control may be interfaced to external control device(s) such as those required by local regulations; such interfaces shall provide only limited access and the mandatory functions of the voice alarm control

voice alarm control and indicating equipment

shall not be overridden. Any faults in the transmission path between the two shall not prevent the operation of the mandatory functions, and shall display a warning if such a fault occurs.

The external control devices should comply with available local codes, European Standards or national standards.

The voice alarm control may contain emergency microphones which shall have priority over all inputs, including pre-recorded messages. Access will be by an appropriate level. Where a pre-alarm tone precedes the activation of the microphone an adjacent indicator will display when the microphone becomes active.

When the emergency microphone is in use any audible indication that causes any interference shall be automatically muted. Where multiple microphones are provided they shall be configured via appropriate access level and only a single microphone can be in use at any one time. Pre-recorded messages shall be stored in non-volatile memory.

All mandatory Indicators shall be visible at 3 m distance for general indications and the supply of power and at 0,8 m distance for others. If flashing indications are used, both the on and off periods shall be a minimum of 0,25 s, and the flash frequency shall be a minimum of 1 Hz for voice alarm indications and 0,2 Hz for fault indications.

If the same led's are used for the indication of faults and disablements, fault indications shall flash and disablement shall be steady. Mandatory indications on an alphanumeric display shall be legible for at least one hour following the display of a new indication of an alarm and 5 min for fault or disablement conditions, at 0,8 m distance, in ambient light of 5 lux to 500 lux. The colours of the general and specific led's shall be red for alarms, yellow for fault, and disablements and green for power. Where voice alarm automatic message status indicators are provided, it might be advantageous to differentiate between evacuation and alert message with red for emergency messages and yellow for alert messages.

section two | an introduction to the suite of EN54 standards

voice alarm control and indicating equipment

Table 1 — Test schedule on voice alarm control equipment

Test	Subclause number
Output power	16.4
Signal-to-noise ratio	16.5
Frequency response of Voice alarm control without microphone(s)	16.6
Frequency response of Voice alarm control with microphone(s)	16.7
Cold (operational)	16.8
Damp heat, steady state (operational) Operational	16.9
Damp heat, steady state (endurance)	16.10
Impact (operational)	16.11
Vibration, sinusoidal (operational)	16.12
Vibration, sinusoidal (endurance)	16.13
Supply voltage variation (operational)	16.14
Electromagnetic Compatibility (EMC), Immunity tests (operational)	16.15 _a

a) Visible and audible indications of purely transitory nature are allowed during the application

section two | an introduction to the suite of EN54 standards

voice alarm control and indicating equipment

Annex to EN54-16

Annex A - Explanation of Access levels

Annex B – Optional functions

Annex C – Design Requirements for software controlled systems

Annex D – General Information

Annex E – Interface between Fire and Voice Alarm controls

Annex F – Common Indications, controls and outputs in combined systems

Annex ZA - deals with the clauses of the standard in respect of their compliance with the mandate of the EU construction products regulation.

part 17 short circuit isolators

Introduction

The purpose of a short-circuit isolator is to limit the consequences of faults in fire alarm circuits, both loops and spurs. Sections of these circuits are separated by installing short circuit isolators at strategic locations, and where applicable in accordance with the national standard of the country of installation where such a standard exists, or where there is no country standard then to the European standard, CEN/TS54-14, or ISO 7240-14.

In addition the short circuit isolators should be installed in accordance with the system manufacturers design limitations to ensure that circuits are not overloaded such as to create volt drop which is also likely to cause similar problems and jeopardise the correct operation of components.

Scope

This standard specifies the requirements and methods of test for short circuit isolators, for use in fire detection

and fire alarm systems. Compliance shall be verified by visual inspection or engineering assessment and successfully tested as described in clause 5. However, for short circuit isolators which are integrated into other devices already covered by an existing European Standard the environmental conditioning shall be performed in accordance with that EN.

Requirements

If the short-circuit isolator incorporates an integral status indicator then this shall not be red.

Where it provides protection to ancillary devices, failures of these connections shall not prevent the correct operation of the short circuit isolator. If the isolating device is detachable (i.e. it is attached to a mounting base), then a means shall be provided to detect the removal of the device from the base in order to give a fault signal. It shall not be possible to change the manufacturer's settings or provide for on-site adjustment of the short-circuit

short circuit isolators

isolator without the use of a code or special tool. For each setting the short circuit isolator shall comply with the requirements of this European Standard.

The functional testing is to verify operation within the manufacturer's specification and to test each condition claimed to cause it to operate and at the maximum specified current. The isolator should open circuit when detecting a short circuit condition and /or excess current causing a volt drop below a level at which the devices will function correctly.

section two | an introduction to the suite of EN54 standards

short circuit isolators

Table 1 – Test schedule

Test	Clause
Reproducibility	5.2
Variation in supply voltage	5.3
Dry heat (operational)	5.4
Cold (operational)	5.5
Damp heat, cyclic (operational)	5.6
Damp heat, steady state (endurance)	5.7
Sulphur dioxide (SO ₂) corrosion (endurance)	5.8
Shock (operational)	5.9
Impact (operational)	5.10
Vibration, sinusoidal (operational)	5.11
Vibration, sinusoidal (endurance)	5.12
Electrostatic discharge (operational)	5.13
Radiated electromagnetic fields (operational)	5.13

section two | an introduction to the suite of EN54 standards

short circuit isolators

Table 1 – Test schedule

Test	Clause
Conducted disturbances induced by electromagnetic fields	5.13
Fast transient bursts (operational)	5.13
Slow high energy voltage surge (operational)	5.13

Annex to EN54-17

Annex A – Examples of testing procedure

Annex B – Impact Test

Annex ZA – deals with the clauses of the standard in respect of their compliance with the mandate of the EU construction products regulation.

part 18 input/output devices

Scope

This Standard specifies the requirements, test methods and performance criteria for input/output devices connected to a fire detection and fire alarm system, which may transmit and/or receive signals which are, necessary for the operation of the fire detection and fire alarm system and/or fire protection system.

An input/output device may be physically separate or its function may be integrated into another device. Control and indicating equipment and ancillary control and indicating equipment (e.g. repeater panels and fire brigade panels) are not covered by this Standard.

Compliance

In order to comply with this Standard, the input/output devices shall be verified by inspection and engineering assessment and shall be successfully tested as described in Clause 5. If the input/output device is detachable then a means shall be provided to detect the removal of the device from its base in order to give a fault signal.

Introduction

The term input/output devices cover a wide range of different types of devices whose applications are different. These may include, digital inputs, monitored inputs for voltage, together with relay outputs, voltage outputs or solid state drivers to switch external devices.

This Standard does not therefore include detailed functional requirements for the devices themselves but requires that their function is sufficiently specified by the manufacturer and that they function correctly in accordance with that specification.

Devices shall be supplied with sufficient data to ensure their correct installation and operation. This data shall include the parameters necessary to define the input and/or output functions (e.g. output voltage and current ratings, alarm and fault trip levels and logic levels).

For devices which rely on software control, these shall meet the requirements of 4.5.2, 4.5.3 and 4.5.4.

input/output devices

Table 1 – Test schedule for input/output devices

Test	Clause
Performance and variation of supply parameters	5.2
Dry heat (operational)	5.3
Cold (operational)	5.4
Damp heat, cyclic (operational)	5.5
Damp heat, steady state (endurance)	5.6
SO ₂ corrosion (endurance)	5.7
Shock (operational)	5.8
Impact (operational)	5.9
Vibration (operational)	5.10
Vibration (endurance)	5.11
Electromagnetic Compatibility (EMC), immunity tests	5.12

section two | an introduction to the suite of EN54 standards

input/output devices

Annex to EN54-18

Annex ZA - deals with the clauses of the standard in respect of their compliance with the mandate of the EU construction products regulation.

part 20 aspirating smoke detectors

Scope

This Standard specifies the requirements, test methods and performance criteria for aspirating smoke detectors for use in fire detection and fire alarm systems.

Aspirating smoke detectors are used for the protection of more special and specific risks.

There are some aspects of the detectors functionality therefore not covered by this standard.

An aspirating smoke detector is one in which air and aerosols are drawn through a sampling device and carried to one or more smoke sensing elements by an integral fan or pump.

To comply with this standard the detector shall meet the requirements of this clause, which shall be verified by inspection and engineering assessment, and, when successfully tested in accordance with those described in Clause 6.

Requirements

Individual alarm indication shall be provided outside of the detector via a red visual indicator which shall be extinguished when the detector is reset. Where conditions other than fire are indicated these shall be clearly distinguishable other than when the detector is in service mode.

The response of an aspirating smoke detector is dependent upon both the sensitivity settings of the smoke sensing element and the design of the sampling device; e.g. pipework and sampling points. In some detectors the smoke sensing sensitivity can be adjusted in order to suit the application and sampling device.

The manufacturer's settings should not be accessible to change without the need for a password, special tool or by the breaking or removal of a seal. The adjustments may be made at the detector or at the control and indicating equipment.

aspirating smoke detectors

Changing the sensitivity settings can affect the classification of the installed detector. If it is possible to reconfigure the detector such that it no longer complies with the standard, then this shall be clearly marked on the detector or in the associated data. The provision of “drift compensation” to counter the effects of a build-up of dirt in the detector, and /or the provision of algorithms to suit an environment shall not significantly reduce the detector’s sensitivity to slowly developing fires.

The sampling pipes and fittings shall have adequate mechanical strength and temperature resistance in accordance with EN 61386-1 to at least Class 1131. Pipes which are not classified by the manufacturer of the detector shall either be tested, as part of the approval, or be supported by evidence that the requirements of this standard are met.

An airflow fault signal will be generated, within 300secs, when the flow is outside the manufacturer’s operational limits. The airflow shall be monitored

to detect leakage or obstruction of the sampling device or pipework sampling point(s). This time is additional to any delay between signalling the fault and its indication at the control panel and is to allow for spurious short term flow variations which would otherwise cause unwanted fault signals.

The power for the aspirating detector shall be supplied by a separate power supply complying with EN 54-4 which may be within the main control and indicating equipment.

Aspirating Smoke Detector systems are classified based upon the sensitivity setting as shown in the table below. The method used for determining the classification is likely to take into account the sizes and number of sampling points, their position along the sampling device/pipe, the sensitivity of the detector and the sampling device/pipework arrangement and its length.

aspirating smoke detectors

Classification table for aspirating smoke detectors

Class	Description	Example application(s)
A	Aspirating smoke detector providing very high sensitivity	Very early detection: the detection of very dilute smoke for example entering air conditioning ducts to detect the extremely dilute concentrations of smoke that might emanate from equipment in the environmentally controlled area such as a clean room.
B	Aspirating smoke detector providing enhanced sensitivity	Early detection: for example special fire detection within or close to particularly valuable, vulnerable or critical items such as computer or electronic equipment cabinets.
C	Aspirating smoke detector providing normal sensitivity	Standard detection: general fire detection in normal rooms or spaces, giving, for example, at least an equivalent level of detection as a point or beam type smoke detection system.

The detectors shall be tested according to the test schedule in the following table.

section two | an introduction to the suite of EN54 standards

aspirating smoke detectors

Test schedule

Test	Clause
Repeatability	6.2
Reproducibility	6.3
Variation of supply voltage	6.4
Dry heat (operational)	6.5
Cold (operational)	6.6
Damp heat, Steady State (operational)	6.7
Damp heat, Steady State (endurance)	6.8
SO ₂ corrosion (endurance)	6.9
Shock (operational)	6.10
Impact (operational)	6.11
Vibration (operational)	6.12
Vibration (endurance)	6.13
Electromagnetic compatibility, Immunity tests	6.14
Fire sensitivity	6.15

aspirating smoke detectors

Fire test requirements for multi-class detectors

Detector Class	Combination of configurations	Configuration to be used	Test fires to be applied (see Annexes B to H)
A only	Config A	Config A	TF2A, TF3A, TF4, TF5A
B only	Config B	Config B	TF2B, TF3B, TF4, TF5B
B only	Config C	Config C	TF2, TF3, TF4, TF5
B and C	Config B = Config C	Config B/C	TF2B, TF3B, TF4, TF5B
B and C	Config B ≠ Config C	Config B Config C	TF2B, TF3B, TF5B TF2, TF3, TF4, TF5
A, B and C	Config A = Config B = Config C	Config A/B/C	TF2A, TF3A, TF4, TF5A
A, B and C	Config A = Config B ≠ Config C	Config A/B Config C	TF2A, TF3A, TF4, TF5A TF2, TF3, TF4, TF5
A, B and C	Config A ≠ Config B = Config C	Config A Config B/C	TF2A, TF3A, TF5A TF2B, TF3B, TF4, TF5B
A, B and C	Config A ≠ Config B ≠ Config C	Config A Config B Config C	TF2A, TF3A, TF5A TF2B, TF3B, TF5B TF2, TF3, TF4, TF5

"Config A" means the worst case configuration for the Class A testing;
 "Config B" means the worst case configuration for the Class B testing;
 "Config C" means the worst case configuration for the Class C testing;
 "=" means that configurations are the same (e.g. Config A = Config B means that the same configuration is used for the Class A testing as for the Class B testing);
 "≠" means that configurations are different (e.g. Config B ≠ Config C means that a different configuration is used for the Class B testing than for the Class C testing).

section two | an introduction to the suite of EN54 standards

aspirating smoke detectors

Annex to EN54-20

Annex A – Response threshold values

Annex B – Test Fire TF2

Annex C - Test Fire TF2A and B

Annex C - Test Fire TF2A and B

Annex D - Test Fire TF3

Annex E - Test Fire TF3A and B

Annex F - Test Fire TF4

Annex G - Test Fire TF5

Annex H - Test Fire TF5A and B

Annex I – Fire test room

Annex J – Slow developing Fires

Annex K – Air Flow test

Annex ZA - deals with the clauses of the standard in respect of their compliance with the mandate of the EU construction products regulation.

part 2 1 alarm transmission and fault warning routing equipment

Scope

This Standard specifies the requirements, test methods and performance criteria for fire alarm and fault routing transmission equipment for use with fire detection and fire alarm systems. If functions other than those specified in this Standard are provided, they shall not jeopardize the functionality required for compliance. Transmission equipment can be type 1 where a dedicated alarm path exists and type 2 for a digital communicator using the public switched telephone network, both in accordance with EN50136-1-1.

Requirements

The alarm transmission routing equipment shall be capable of receiving fire alarm signals from the Control and indicator panel and faults from the transmission network which together with acknowledgements from the alarm receiving centre will be transmitted to the control and indicator panel. It shall also be capable of transmitting fire alarm signals to the alarm receiving centre.

The fault warning routing equipment shall be capable of receiving fault warning signal from the control and indicator panel and from the transmission network and transmitting faults to both the control and indicator panel and the alarm receiving centre.

Indication of signals shall be provided at the transmission equipment, via led's, or at the control and indicator equipment for both the received acknowledgement signal from the alarm receiving centre as defined in EN 50136-2-1 and at least one common fault warning be used to indicate the following:

- 1) if the acknowledgement signal is not received at the routing equipment within 100 s for type 1 and 240 s for type 2 of the initiation of the transmitted fire alarm.
- 2) a failure within the routing equipment (e.g. power supply failure).
- 3) a failure within the alarm transmission network.

alarm transmission and fault warning routing equipment

4) where the routing equipment and the fire alarm control panel are in separate enclosures and where a fault exists on the interconnection path, a fault signal shall be indicated locally and transmitted to the alarm receiving centre.

The routing equipment enclosure shall be of robust construction, consistent with the recommended installation method and shall be a minimum of IP30 of EN 60529.

All light emitting indicators shall be clearly labelled with the information being legible at 0,8 m distance in an ambient light intensity from 100 lux to 500 lux. If flashing indications are used, the on/off-periods shall be a minimum of 0,25 s and the flash frequency not less than 0,2 Hz for fault indications. The light-emitting indicators shall be yellow for fault and red for the indication of the acknowledgement. All terminals and fuses shall be clearly labelled.

If the processing and transmission of fire and fault signals is achieved in se-

parate equipment then both can operate simultaneously. If the signals are combined in a single piece of equipment then the fire signal shall take priority. A fault in any transmission path between the routing equipment and the transmission network (as defined in EN 50136-1-1) shall not affect the routing equipment or any other transmission path.

The power supply for the transmission equipment shall be in accordance with EN54-4. If the power supply is within a separate enclosure then duplicate paths will be arranged so that failure in one does not isolate the transmission equipment. The change over from the primary to standby power supply shall not affect any indications other than those specifically associated with power supplies. Any provision for disconnecting or adjusting the power supply to the equipment will not be readily accessible, without the required access.

Access shall be provided on the routing equipment, from level 1 (most acces-

alarm transmission and fault warning routing equipment

sible) to level 4 (least accessible). Manual controls and other functions shall be grouped on the appropriate access level, as specified in EN 54-2.

Environmental tests

Test	Clause number
Cold	10.4
Damp heat, steady state, (operational)	10.5
Impact	10.6
Vibration, sinusoidal, (operational)	10.7
Electromagnetic compatibility (EMC) immunity tests	10.8
Supply voltage variations	10.9
Damp heat, steady state, (endurance)	10.10
Vibration, sinusoidal, (endurance)	10.11

section two | an introduction to the suite of EN54 standards

alarm transmission and fault warning routing equipment

Annex to EN54-21

Annex A – Performance requirements for type 1 and 2 systems

Annex B – Verification of performance requirements

Annex C – Design requirements for software

Annex ZA - deals with the clauses of the standard in respect of their compliance with the mandate of the EU construction products regulation.

part 23 fire alarm devices – visual alarm devices

Introduction

This Standard specifies the requirements, test methods and performance criteria for visual alarm devices in a fire detection and alarm system which are intended to signal a warning of a fire.

It applies only to pulsing or flashing visual alarm devices, such as xenon or rotating beacons.

In order to comply devices shall meet the requirements of Clause 4, which shall be verified by visual inspection or engineering assessment and shall be successfully tested as described in Clause 5.

Requirements

The purpose of a visual fire alarm device is to warn persons within, or close to a building of the outbreak of a fire. This Standard allows manufacturers to specify devices in terms of the range at which the required illumination is met. Three categories are defined; for ceiling and wall mounted devices and an open category. The maximum range of the

visual alarm device is tested by measuring its light output in the surrounding hemisphere. As the light output can vary over time a test is made to check that any variation is acceptable. This Standard gives common requirements for the construction as well as for their performance under varying conditions. Devices are classified as Type A, indoor and Type B, outdoor. The degree of protection provided by the enclosure shall be IP21 for Type A and IP33 for type B, in accordance with EN 60529.

The device shall be rated for a minimum of 100 hours which will not affect its ability to cycle on and off as required as part of the compliance testing. This requirement does not apply to the capacity of any integral batteries used as a means of providing local standby power. The capacity and charging requirements of such batteries should meet the requirement of the system.

Access to the device shall be restricted by the use of special screws or tools and it should not be possible to change the manufacturer's settings without

fire alarm devices – visual alarm devices

use of the same or by breaking a seal. If on site adjustment of the device settings is provided, then the factory setting, which complies with this standard, should be clearly displayed for each. Any settings which are not compliant with this standard shall only be accessible by the same means and it should be clearly displayed, either on the device or in data format that the device does not comply with this standard. The adjustments may be carried out either at the device or via the control and indicator equipment.

Visual alarm devices shall meet the requirement for coverage as either a 'C', ceiling mounted, or 'W', wall mounted, or 'O', open class device.

Category C devices shall be further specified as C-x-y where: x is either 3, 6 or 9 and is the maximum ceiling mounting height in metres and y is the diameter, in metres, of the coverage. e.g. C-3-12 would represent a 12 metre diameter coverage when mounted at 3 metres. Category W devices shall be further specified as W-x-y where x is the maxi-

imum wall mounting height in metres, with a minimum value of 2.4 m; and y is the width of a square room, in metres covered by the device. e.g. W-2,4-6 represents a device mounted at a height of 2.4m in a room measuring 6mx6m. For category O devices the coverage volume in which the required illumination is achieved shall be specified.

The visual alarm device shall produce either red or white light of at least 1 candela for 70 % of all measurement points and shall not exceed 500 cd for any measurement points. The flash rate shall be between 0.5 and 2 Hz measured at 10 % of the peak values of consecutive leading edges of the first pulse of each flash. The maximum on time, measured between the leading and trailing edge shall not exceed 0.2 s. The light temporal pattern and frequency of flashing may vary in different countries and therefore reference needs to be made to local regulations. Flashing lights may require synchronization to prevent the possibility of a flash frequency/temporal pattern; that could adversely affect some occu-

section two | an introduction to the suite of EN54 standards

fire alarm devices – visual alarm devices

pants inducing epileptic fits when multiple devices are within a field of view. In such cases, devices shall meet the requirements of the test described in 5.3.7.

Technical data regarding both installation and maintenance should be provided with each device or in supporting documentation.

section two | an introduction to the suite of EN54 standards

fire alarm devices – visual alarm devices

Table 1 – Test schedule

Test _c	Clause
Reproducibility	5.1.7
Duration of operation	5.2.1
Enclosure protection	5.2.4
Coverage volume	5.3.1
Variation of light output	5.3.2
Synchronization (option with requirements)	5.3.7
Dry heat (operational)	5.4.1.1
Dry heat (endurance)	5.4.1.2
Cold (operational)	5.4.1.3
Damp heat, cyclic (operational)	5.4.2.1
Damp heat, steady state (endurance)	5.4.2.2
Damp heat, cyclic (endurance)	5.4.2.3
Shock (operational)	5.4.3.1

fire alarm devices – visual alarm devices

Table 1 – Test schedule

Test _c	Clause	
Impact (operational)	5.4.3.2	
Vibration (operational)	5.4.3.3	
Vibration (endurance)	5.4.3.4	
SO2 corrosion (endurance)	5.4.4	
Electromagnetic compatibility (EMC), immunity (operational): <ul style="list-style-type: none"> · Electrostatic discharge · Radiated electromagnetic fields · Conducted disturbances induced by electromagnetic fields · Voltage transients fast transient bursts · Voltage transients slow high energy voltage surge 	5.4.5 _b	
<p>_b The EMC tests specified in 5.4.5 are not required for devices which do not rely on active electronic components for their operation.</p> <p>_c The tests on an individual specimen may be carried out in any order except that the reproducibility test (5.1.7) shall be performed first on all specimens and the tests on specimen 2 shall be carried out in the order listed, except for the enclosure protection test, 5.2.4, which shall be conducted last.</p>		

section two | an introduction to the suite of EN54 standards

fire alarm devices – visual alarm devices

Annexes to EN54-23

Annex A – Measuring light distribution

Annex B – Comparative light output measurement

Annex C – Light test chamber

Annex D – Flammability test requirements

Annex ZA - deals with the clauses of the standard in respect of their compliance with the mandate of the EU construction products regulation.

part 24 components of voice alarm systems - loudspeakers

Introduction

This Standard specifies the requirements, test methods and performance criteria for voice alarm loudspeakers for use with fire detection and fire alarm systems. For compliance, voice alarm loudspeakers shall be verified by visual inspection or engineering assessment and shall be successfully tested as described in Clause 5.

The purpose of a voice alarm loudspeaker is to provide intelligible warning to person(s) of a fire, whilst at the same time advising appropriate methods of evacuation. Providing such information speeds up a person's response time to an incident, removes uncertainty, allowing evacuation times to be reduced. Voice alarm loudspeakers need to achieve a minimum acoustical performance, as well as constructional and environmental requirements, to be suitable for use in fire detection and fire alarm systems.

Requirements

This standard recognizes that the performance of voice alarm loudspeakers will vary according to the nature of the space into which they are installed. It therefore specifies the minimum requirements and a common method for testing their operational performance against parameters specified by the manufacturer.

As the types of loudspeaker included are electromechanical devices without sensitive electronics, electromagnetic compatibility (EMC) tests are excluded. Loudspeakers are suitable for either indoor, type A or outdoor, type B, applications as specified. Type B loudspeakers can be beneficial in some indoor situations where high temperature and/or humidity are present. For type A the degree of protection required is to IP21 and for type B, IP33 of EN 60529.

Loudspeakers suitable for special applications or hazardous areas are not covered by this standard.

components of voice alarm systems - loudspeakers

The voice alarm loudspeaker shall be rated for a minimum of 100 hours operation at the rated noise power specified by the manufacturer. Access to the device will be limited and require special tools, codes, or be restricted by the use of hidden screws or seals.

Voice alarm loudspeakers shall be clearly marked and in addition to the standard data, detailed in the overview shall contain information relative to the rated noise voltage for transformer-coupled loudspeakers; the rated impedance for direct-coupled loudspeakers; the rated noise power at the highest power setting; and the various power settings (e.g. transformer tapping options for transformer-coupled loudspeakers).

Some loudspeakers are a combination of one or more housings together with a termination box and an interconnecting cable. The housing(s), cable(s) and terminal box should be considered to be 'the loudspeaker' for the purposes of this Standard. Examples include: pendant types and

those with adjustable orientation such as horn or column loudspeakers and loudspeaker arrays.

The maximum sound pressure level is expressed in dB and measured at a distance of 4 metres from the reference point on the reference axis over a period of at least 30s. The loudspeaker shall be deemed to conform to the rated sound pressure test if the sound pressure level is greater or equal to the value specified by the manufacturer.

The loudspeakers shall be constructed using materials capable of withstanding the tests detailed in clause 5.

Plastic materials shall conform to EN60695-11-10 when operating on a voltage $\leq 30V$ RMS or 42.4 V dc with less than 15 watts of power, or, EN 60695-11-20 when operating on a voltage $\geq 30V$ RMS or 42.4 V dc with less than 15 watts of power.

components of voice alarm systems - loudspeakers

Table 1 – Schedule of tests

Test c	Subclause
Reproducibility (frequency response / sensitivity)	5.2
Rated impedance	5.3
Horizontal and vertical coverage angles	5.4
Maximum sound pressure level	5.5
Rated noise power (durability)	5.6
Dry heat (operational)	5.7
Dry heat (endurance)	5.8
Cold (operational)	5.9
Damp heat, cyclic (operational)	5.10
Damp heat, steady state (endurance)	5.11
Damp heat, cyclic (endurance)	5.12
SO ₂ corrosion (endurance)	5.13
Shock (operational)	5.14

section two | an introduction to the suite of EN54 standards

components of voice alarm systems - loudspeakers

Table 1 – Schedule of tests

Test c	Subclause
Impact (operational)	5.15
Vibration, sinusoidal (operational)	5.16
Vibration, sinusoidal (endurance) 5.17 7	5.17
Enclosure protection	5.18

section two | an introduction to the suite of EN54 standards

components of voice alarm systems - loudspeakers

Annexes to EN54-24

Annex A – Acoustical Measurements

Annex B – Rated noise power

Annex C – Physical references

Annex ZA; deals with the clauses of the standard in respect of their compliance with the mandate of the EU construction products regulation.

part 25 components using radio links

Introduction

The purpose of this Standard is to define additional requirements to other parts of EN 54 that allow compliant radio fire detection systems and components to be at least as efficient and stable as approved wired fire detection systems. Systems and components are covered because it is difficult to describe the components separately. Limitations with respect to the use of radio components may be specified in national technical rules or guidelines and consideration should be given to the frequencies, bands and channels used by radio based systems. The requirements in this standard shall apply together with those in other parts of EN54 where the component has the same function as that covered in the other standard, and when not specifically covered in this standard. e.g. A heat detector installed on a wireless system will comply with EN54-5

Scope

This Standard specifies the requirements, test methods and performance criteria for both systems and components used in fire alarms systems which use radio frequency links to communicate. Compliance with this standard requires the components to meet these requirements which shall be verified by visual inspection or engineering assessment, and successfully tested as described in Clause 8.

Where combined wired and radio systems are used the relevant part of EN54 together with this standard will both apply. The requirements for wired systems are superseded or modified by this standard. This document does not cover those issues which relate to national regulations which may vary from country to country, and which may include frequencies, power and limitations of losses on circuits or radio links.

components using radio links

Requirements

The manufacturer shall provide a safeguard to ensure any attenuation, which may be caused by differing influences on site, does not affect the radio link in such a way as to prevent communication between components. The limits will be at least 10dB for frequencies up to 10MHz and as defined in Annex B for frequencies greater than 10MHz. The system shall use a secure transmission protocol which ensures that signals are not lost. Each component will be marked individually as an indication that they belong to the same system and components belonging to different systems should not be compatible.

The system should demonstrate immunity to its own radio influences and others on the spectrum. Those produced as a result of electromagnetic affects are covered by those guidelines in EN50130-4. Influences as a result of a direct attack is not covered or required in the EN54 standards. Where two or similar systems from the same manufacturer are operating within range it

shall be ensured that they do not affect each other. The manufacturer shall also ensure that signal transmission is possible, without causing interference, even if other users are working in the same band. Interference to a single receiver shall not cause alarm or fault messages at the control equipment. If any radio linked component is unable to transmit a message to the CIE within EN 54-2 defined periods it shall be indicated in less than 100 s.

Power supplied to the components shall be via a primary battery or an external power supply unit complying with EN54-4. Components powered by the independent power source shall be contained within the same enclosure. The battery shall have a minimum life of 3 years. The system requirements shall not cause the battery to discharge below 85% by end of life. The remaining 15 % of the rated capacity takes account of self-discharge of the power source.

All components powered from the independent power source shall be

section two | an introduction to the suite of EN54 standards

components using radio links

capable of transmitting a fault signal (low power) before the power source fails whilst still functioning.

Annexes to EN54-25

Annex A – Radio frequency shielded test

Annex B – Immunity to attenuation

Annex C - Autonomous power supply

Annex ZA; deals with the clauses of the standard in respect of their compliance with the mandate of the EU construction products regulation.

part 26 carbon monoxide detectors - point detectors

Scope

The standard specifies the requirements, test methods and performance criteria for point type carbon monoxide fire detectors for use in fire detection and fire alarm systems. This standard applies only to those detectors sensing CO and not those combining other elements, sensing different fire phenomena. The tests are designed for standard detectors and do not cover those which might be construed as special, incorporating non-standard features.

Requirements

Carbon monoxide (CO) is a product of the incomplete combustion of carbon-based materials. CO fire detectors can provide a faster response than other types because CO is dispersed by convection and diffusion. CO fire detectors might also be less prone to unwanted alarms than other fire detection techniques due to the absence of CO in most dusts and vapors.

The objective of this standard is to prove that the sensitivity and reliability fall within acceptable parameters and that such a detector is suitable for use in systems protecting life and/or property. CO detectors may not be suitable for the early detection of certain classes of fires, typically electrical fires and those likely to flame rather than smoulder. It is recommended that a risk assessment is carried out to ensure the suitability of CO detectors as they should not be considered a direct replacement for smoke detectors, either optical or ionisation.

CO sensing techniques may vary but may be affected by other gases and phenomena. The test schedule for such detectors therefore includes an assessment of their ability to ignore substances that may co-exist in the detectors environment.

CO detectors are beneficial in detecting smouldering fires and therefore the test schedule include test fires TF2 and 3, (EN54-7) only. Both tests have added criterion to enhance their suitability for this type of detector.

carbon monoxide detectors - point detectors

Compliance for the detector to meet the requirements of this standard shall be verified by visual inspection or engineering assessment, or tested as described in clause 5.

Individual alarm indication shall be provided via a red visual indicator which shall be extinguished when the detector is reset. Where conditions other than fire are indicated these shall be clearly distinguishable other than when the detector is in service mode. For detachable detectors the indicator may be in the head or the base and should be visible at a distance of 6 metres directly below the detector in ambient light levels of up to 500 lux. Where there is a connection to remote indicators, control relays etc., failures of these connections shall not prevent the correct operation of the detector.

Monitoring of detachable detectors shall be provided by which removal of the detector from its base without some form of indication is not possible. The manufacturer's settings should not be accessible to change without the need for a password, special tool or by

the breaking or removal of a seal. If on site adjustment of the detectors response type is provided, then the factory setting, which complies with this standard, should be clearly displayed for each detector and should only be accessible to change with a password or special tool or by the removal of the detector from its base. Any settings which are not compliant with this standard shall only be accessible by the same means and it should be clearly displayed, either on the detector or in data format, that if these are used the detector does not comply with this standard. The adjustments may be carried out either at the detector or via the control and indicator equipment.

The response of the detector may depend upon the rate of change of CO in the vicinity. Any form of compensation allowing the detector to discriminate between normal CO levels and those indicative of a fire, shall not significantly reduce the detectors ability to detect fire nor make it more susceptible to unwanted alarms.

carbon monoxide detectors - point detectors

The provision of “drift compensation” to counter the effects of ageing of the detector shall not significantly reduce the detector’s sensitivity to slowly developing fires. To verify this, an assessment of the detector’s response to slowly developing fires shall be made as specified in 5.2.3.

The detector will demonstrate its stability after a number of alarm conditions as specified in clause 5.2.5. Multiple detectors shall demonstrate similar degrees of sensitivity, as specified in 5.2.6.

Those detectors whose performance is tied to software shall conform to the requirements of 4.3.5.2, 3 and 4.

section two | an introduction to the suite of EN54 standards

carbon monoxide detectors - point detectors

Table 1 – Test schedule

Test	Clause
Repeatability	5.2.4
Directional dependance	5.2.5
Reproducibility	5.2.6
Air movement	5.2.7
Long term stability	5.3.6
Variations in supply parameters	5.4.1
Dry heat (operational)	5.6.1.1
Dry heat (endurance)	5.6.1.2
Cold (Operational)	5.6.1.3
Damp heat,cyclic (operational)	5.6.2.1
Damp heat, steady state (operational)	5.6.2.2
Damp heat, steady state (endurance)	5.6.2.3
Low humidity, steady state(operational)	5.6.2.4

carbon monoxide detectors - point detectors

Table 1 – Test schedule

Test	Clause
Sulphur dioxide SO ₂ corrosion(endurance)	5.6.3
Shock (operational)	5.6.4.1
Impact (operational)	5.6.4.2
Vibration, sinusoidal(operational)	5.6.4.3
EMC, immunity tests (operational) - Electrostatic discharge - Radiated electromagnetic fields - Conducted disturbances induced by electromagnetic fields - Fast transient bursts - Slow high energy voltage surge	5.6.5.1a
Exposure to high levels of carbon monoxide	5.6.6.1
Exposure to chemical agents at environmental concentrations	5.6.6.2
Fire sensitivity	5.5.1

^{a)} In the interests of test economy , it is permitted to use the same specimen for more than 1 EMC test. In that case intermediate functional test(s) on the specimen(s) used for more than one test can be deleted and the functional test conducted at the end of the sequence of tests. However it should be noted that in the event of a failure, it may not be possible to identify which test exposure caused the failure. (see EN 50130-4:2011,clause 4).

section two | an introduction to the suite of EN54 standards

carbon monoxide detectors - point detectors

Annexe to EN54-26

Annexe A - Gas Test Chamber spec

Annexe B - CO and Smoke measuring instruments

Annexe C - Fire Test room

Annexe D - Establishing exposure level of chemical agents

Annexe E - Smouldering (pyrolysis) wood fire test (TF2)

Annexe F - Glowing smouldering cotton fire test (TF3)

Annexe G - Construction of Gas test chamber

Annexe H - Apparatus for impact test

Annexe ZA - deals with the clauses of the standard in respect

of their compliance with the mandate of the EU Construction product Regulation

part 29 multi sensor fire detectors - point detectors using both smoke and heat detection

Scope

Multi-sensor fire detectors combining both smoke, (optical or ionisation) detection and heat detection technology and in compliance with this document are classed as general purpose fire detectors. Such detectors can detect both a wider range of fire types whilst being less prone to generating unwanted alarms. For multisensor type devices, additional environmental tests are carried out in order to demonstrate increased stability. Special detectors for special applications are not covered by this standard. It should be noted that in certain countries the use of ionisation detectors is banned due to their being a radioactive source present.

Fire tests include TF1, 2, 5 and 8 in order for the detector to demonstrate its response to the wider range of fires. The detection channels do not individually need to satisfy the requirements of the relevant heat and smoke detection standards, in addition to meeting the requirements of this standard.

Requirements

Compliance for the detector to meet the requirements of clause 4 of this standard shall be verified by visual inspection or engineering assessment, or tested as described in clause 5.

Individual alarm indication shall be provided via a red visual indicator which shall be extinguished when the detector is reset. Where conditions other than fire are indicated these shall be clearly distinguishable other than when the detector is in service mode. For detachable detectors the indicator may be in the head or the base and should be visible at a distance of 6 metres directly below the detector in ambient light levels of up to 500 lux.

Where there is a connection to remote indicators, control relays etc., failures of these connections shall not prevent the correct operation of the detector.

Monitoring of detachable detectors shall be provided by which removal of the detector from its base without some form of indication is not possible.

multi sensor fire detectors - point detectors using both smoke and heat detection

The manufacturer's settings should not be accessible to change without the need for a password, special tool or by the breaking or removal of a seal. If on site adjustment of the detectors response type is provided, then the factory setting, which complies with this standard, should be clearly displayed for each detector and should only be accessible to change with a password or special tool or by the removal of the detector from its base. Any settings which are not compliant with this standard shall only be accessible by the same means and it should be clearly displayed, either on the detector or in data format, that if used the detector does not comply with this standard. The adjustments may be carried out either at the detector or via the control and indicator equipment.

The provision of "drift compensation" to counter the effects of contamination of the detector shall not significantly reduce the detector's sensitivity to slowly developing fires. To verify this, an assessment of the detector's response to

slowly developing fires shall be made as specified in 5.2.2.

The detector will demonstrate its stability after a number of alarm conditions as specified in clause 5.2.3. The sensitivity of the detector to both heat and smoke shall not be unduly dependent upon air flow and in this respect will be assessed in accordance with 5.2.4 and 5.

The heat detectors sensitivity in isolation shall not exceed that stated in EN54-5-2000, with amendments, which shall be assessed as detailed in 5.2.6. Detectors used for testing shall demonstrate similar sensitivities, (5.2.7/8) and optical type smoke detectors will not be affected when in close proximity to artificial light as assessed in 5.2.9.

Those detectors whose performance is tied to software shall conform to the requirements of 4.3.6.2, 3 and 4.

multi sensor fire detectors - point detectors using both smoke and heat detection

Table 1 – Test schedule

Test	Clause
Repeatability of smoke response	5.2.3
Directional dependance of smoke response	5.2.4
Directional dependance of heat response	5.2.5
Lower limit of heat sensitivity	5.2.6
Reproducibility of smoke response	5.2.7
Reproducibility of heat response	5.2.8
Air movement	5.2.9
Dazzling	5.4.1
Fire sensitivity	5.5.1
Dry heat (operational)	5.6.1.1
Cold (operational)	5.6.1.2
Damp heat cyclic (operational)	5.6.2.1
Damp heat steady (endurance)	5.6.2.2

multi sensor fire detectors - point detectors using both smoke and heat detection

Table 1 – Test schedule

Test	Clause
Shock (operational)	5.6.3.1
Impact (operational)	5.6.3.2
Vibration , sinusoidal (operational)	5.6.3.3
Vibration , sinusoidal (endurance)	5.6.3.4
Electrostatic discharge (operational)	5.6.4.1a
Radiated magnetic fields (operational)	
Conducted disturbances induced by electromagnetic fields (operational)	
Fast transient bursts (operational)	
Slow high energy voltage surge (operational)	
Sulphur dioxide SO ₂ corrosion (endurance)	5.6.5.1

^{a)} In the interests of test economy , it is permitted to use the same specimen for more than 1 EMC test. In that case intermediate functional test(s) on the specimen(s) used for more than one test can be deleted and the functional test conducted at the end of the sequence of tests. However it should be noted that in the event of a failure, it may not be possible to identify which test exposure caused the failure. (see EN 50130-4:2011, clause 4).

multi sensor fire detectors - point detectors using both smoke and heat detection

Annexe to EN54-29

Annexe A - Smoke tunnel specification

Annexe B - Test Aerosol for smoke detector response

Annexe C - Smoke measuring instruments

Annexe D - Heat tunnel specification

Annexe E - Apparatus for Dazzling test

Annexe F - Apparatus for impact test

Annexe G - Fire test room

Annexe H Open wood fire (TF1)

Annexe I - Smouldering (pyrolysis) wood fire (TF2)

Annexe J - Glowing smouldering cotton fire (TF3)

Annexe K - Open plastic (polyurethane) fire (TF4)

Annexe L - Liquid (heptane) fire (TF5)

Annexe M - Low temperature black smoke (declane) liquid fire (TF8)

Annexe N - Construction of the smoke tunnel

Annexe O - Construction of the heat tunnel

Annexe P - Test procedures and requirements for the response to slow developing fires

Annexe Q - Construction and measurement of ionisation chamber

Annexe ZA - deals with the clauses of the standard in respect of their compliance with the mandate of the EU Construction product Regulation

part 30 multi- sensor fire detectors - point detectors using a combination of carbon monoxide and heat sensors

Scope

Carbon monoxide (CO) is a product of the incomplete combustion of carbon-based materials. CO fire detectors can provide a faster response than other types because CO is dispersed by convection and diffusion. CO fire detectors might also be less prone to unwanted alarms than other fire detection techniques due to the absence of CO in most dusts and vapors.

Multi-sensor fire detectors combining both carbon monoxide and heat detection technologies and in compliance with this document are classed as general purpose fire detectors. Such detectors can detect both a wider range of fire types whilst being less prone to generating unwanted alarms.

Detectors incorporating CO and heat detection technologies will be more responsive to fires producing flame/heat and less CO than that required to activate a CO detector, as the two detection channels combine, effectively increasing the sensitivity of the CO channel.

For multisensor type devices, additional environmental tests are carried out in order to demonstrate increased stability. Special detectors for special applications are not covered by this standard.

Fire tests include TF1, 2, 5 and 8 in order for the detector to demonstrate its response to the wider range of fires. The detection channels do not individually need to satisfy the requirements of the relevant heat and smoke detection standards, in addition to meeting the requirements of this standard.

Requirements

Compliance for the detector to meet the requirements of clause 4 of this standard shall be verified by visual inspection or engineering assessment, or tested as described in clause 5.

multi- sensor fire detectors - point detectors using a combination of carbon monoxide and heat sensors

Individual alarm indication shall be provided via a red visual indicator which shall be extinguished when the detector is reset. Where conditions other than fire are indicated these shall be clearly distinguishable other than when the detector is in service mode. For detachable detectors the indicator may be in the head or the base and should be visible at a distance of 6 metres directly below the detector in ambient light levels of up to 500 lux. Where there is a connection to remote indicators, control relays etc., failures of these connections shall not prevent the correct operation of the detector.

Monitoring of detachable detectors shall be provided by which removal of the detector from its base without some form of indication is not possible. The manufacturer's settings should not be accessible to change without the need for a password, special tool or by the breaking or removal of a seal. If on site adjustment of the detectors response type is provided, then the factory setting, which complies with this standard, should be clearly displayed

for each detector and should only be accessible to change with a password or special tool or by the removal of the detector from its base. Any settings which are not compliant with this standard shall only be accessible by the same means and it should be clearly displayed, either on the detector or in data format, that if used the detector does not comply with this standard. The adjustments may be carried out either at the detector or via the control and indicator equipment.

The provision of "drift compensation" to counter the effects of contamination of the detector shall not significantly reduce the detector's sensitivity to slowly developing fires. To verify this, an assessment of the detector's response to slowly developing fires shall be made as specified in 5.2.3.

The detector will demonstrate its stability after a number of alarm conditions as specified in clause 5.2.4. The sensitivity of the detector to both heat and CO shall not be unduly dependent upon airflow and in this respect will be asses-

section two | an introduction to the suite of EN54 standards

multi- sensor fire detectors - point detectors using a combination of carbon monoxide and heat sensors

sed in accordance with 5.2.5 and 6.

The heat detectors sensitivity in isolation shall not exceed that stated in EN54-5, which shall be assessed as detailed in 5.2.7.

Those detectors whose performance is tied to software shall conform to the requirements of 4.3.6.2, 3 and 4.

multi- sensor fire detectors point detectors using a combination of carbon monoxide and heat sensors

Table 1 – Test schedule

Test	Clause
Repeatability of CO response	5.2.4
Direction dependance of CO response	5.2.5
Direction dependance of heat response	5.2.6
Lower limit of heat response	5.2.7
Reproducibility of CO response	5.2.8
Reproducibility of heat response	5.2.9
Air movement	5.2.10
Long term stability (operational)	5.3.6
Tolerance to supply voltage , variations in supply parameters	5.4
Dry heat (operational)	5.6.1.1
Dry heat (endurance)	5.6.1.2
Cold (operational)	5.6.1.3

section two | an introduction to the suite of EN54 standards

multi- sensor fire detectors point detectors using a combination of carbon monoxide and heat sensors

Table 1 – Test schedule

Test	Clause
Damp heat cyclic (operational)	5.6.2.1
Damp heat steady-state (operational)	5.6.2.2.
Damp heat steady-state (endurance)	5.6.2.3
Low humidity steady state (operational)	5.6.2.4
Shock (operational)	5.6.4.1
Impact (operational)	5.6.4.2
Vibration, sinusoidal (operational)	5.6.4.3
Vibration, sinusoidal (endurance)	5.6.4.4
Electromagnetic Compatibility (EMC) , immunity tests (operational) Radiated electro magnetic fields (operational) Conducted disturbances induced by electromagnetic fields (operational) Fast transient bursts (operational) Slow high energy voltage surge (operational)	5.6.5a

multi- sensor fire detectors point detectors using a combination of carbon monoxide and heat sensors

Table 1 — Test schedule

Test	Clause
Sulphur dioxide SO2 corrosion (endurance)	5.6.3
Exposure to high levels of carbon monoxide	5.6.6.1
Exposure to chemical agents at environmental concentrations	5.6.6.2
Fire sensitivity	5.5.3a

^{a)} In the interests of test economy, it is permitted to use the same specimen for more than one EMC test. In that case, intermediate functional test on the specimens used for more than one test can be deleted, and the functional test conducted at the end of the sequence of tests. However it should be noted that in the event of a failure, it may not be possible to identify which test exposure caused the failure.(see EN 50130-4:2011, clause 4).

section two | an introduction to the suite of EN54 standards

multi- sensor fire detectors point detectors using a combination of carbon monoxide and heat sensors

Annexe to EN54-30

Annexe A - Gas chamber specification

Annexe B - Fire Test Room

Annexe C - CO measuring instrument

Annexe D - concentration of chemical agent for test gases

Annexe E - Heat tunnel specification

Annexe F - Smouldering (pyrolysis) wood fire (TF2)

Annexe G - Glowing smouldering cotton fire (TF3)

Annexe H - Open plastics (polyurethane) fire (TF4)

Annexe I - Liquid (heptane) fire (TF5)

Annexe J - Construction of gas test chamber

Annexe K - Construction of the heat tunnel

Annexe L - Impact test apparatus

Annexe ZA -deals with the clauses of the standard in respect of their compliance with the mandate of the EU Construction product Regulation

part 3 1: multi- sensor fire detectors - point detectors using a combination of smoke, carbon monoxide and heat sensors

Scope

Multi-sensor fire detectors combining smoke, carbon monoxide and heat detection technologies and in compliance with this document are classed as general purpose fire detectors. Such detectors can detect both a wider range of fire types whilst being less prone to generating unwanted alarms.

Detectors are categorised as M/N (without heat sensor) and MT/NT (with heat sensor). These are introduced in order to distinguish between different detector behavior and to identify detectors or settings including the output of an optional heat detector.

For multisensor type devices, additional environmental tests are carried out in order to demonstrate increased stability. Special detectors for special applications are not covered by this standard.

Fire tests include TF1, 2, 5 and 8 in order for the detector to demonstrate its response to the wider range of fires. The detection channels do not indivi-

dually need to satisfy the requirements of the relevant heat and smoke detection standards, in addition to meeting the requirements of this standard.

Requirements

Compliance for the detector to meet the requirements of this standard shall be verified by visual inspection or engineering assessment, or tested as described in clause 5. Category M and N signifies those without a heat sensor output. Category M are designed not to alarm in the presence of a single high channel output whilst those in an N category will. Categories MT and NT signifies detectors which have an output from a heat channel with the former being, as an M and the latter as an N in their response to a single channel high output. The requirements of 4.8.1 and 2 apply to category M detectors with an additional category 4.8.3 also applying to MT detectors. Both category N and NT are exempt from the requirements of 4.8.

multi-sensor fire detectors - point detectors using a combination of smoke, carbon monoxide and heat sensors

Individual alarm indication shall be provided via a red visual indicator which shall be extinguished when the detector is reset. Where conditions other than fire are indicated these shall be clearly distinguishable other than when the detector is in service mode. For detachable detectors the indicator may be in the head or the base and should be visible at a distance of 6 metres directly below the detector in ambient light levels of up to 500 lux. Where there is a connection to remote indicators, control relays etc., failures of these connections shall not prevent the correct operation of the detector.

Monitoring of detachable detectors shall be provided by which removal of the detector from its base without some form of indication is not possible. The manufacturer's settings should not be accessible to change without the need for a password, special tool or by the breaking or removal of a seal. If on site adjustment of the detectors response type is provided, then the factory setting, which complies with this standard, should be clearly displayed

for each detector and should only be accessible to change with a password or special tool or by the removal of the detector from its base. Any settings which are not compliant with this standard shall only be accessible by the same means and it should be clearly displayed, either on the detector or in data format, that if used the detector does not comply with this standard. The adjustments may be carried out either at the detector or via the control and indicator equipment.

The provision of "drift compensation" to counter the effects of contamination of the detector shall not significantly reduce the detector's sensitivity to slowly developing fires. To verify this, an assessment of the detector's response to slowly developing fires shall be made as specified in 5.2.2.

multi- sensor fire detectors - point detectors using a combination of smoke, carbon monoxide and heat sensors

The detector will demonstrate its stability after a number of alarm conditions as specified in clause 5.2.4. and 6. The sensitivity of the detector to both smoke and CO shall not be unduly dependent upon airflow and in this respect will be assessed in accordance with 5.2.5 and 7. For category MT and NT detectors the same conditions shall apply to the heat channel as specified in 5.2.8., detectors will not be affected when in close proximity to artificial light as assessed in 5.2.14.

The heat detectors sensitivity in isolation shall not exceed that stated in EN54-5-2000, with amendments, which shall be assessed as detailed in 5.2.9.

Those detectors whose performance is tied to software shall conform to the requirements of 4.3.6.2, 3 and 4.

multi- sensor fire detectors - point detectors using a combination of smoke, carbon monoxide and heat sensors

Table 1 – Test schedule

Test	Clause
Repeatability of smoke response	5.2.4
Directional dependance of smoke response	5.2.5
Repeatability of CO response	5.2.6
Directional dependance of CO response	5.2.7
Directional dependance of heat response	5.2.8a
Lower limit of heat response	5.2.9a
Reproducibility of smoke response	5.2.10
Reproducibility of CO response	5.2.11
Reproducibility of heat response	5.2.12a
Air movement	5.2.13
Dazzling	5.2.14
Long term stability	5.3.7

multi- sensor fire detectors - point detectors using a combination of smoke, carbon monoxide and heat sensors

Table 1 – Test schedule

Test	Clause
Variations in supply parameters	5.4.1
Fire sensitivity	5.5.1
Dry heat (operational)	5.6.1.1
Dry heat (endurance)	5.6.1.2
Cold (operational)	5.6.1.3
Damp heat cyclic (operational)	5.6.2.1
Damp heat steady state (operational)	5.6.2.2
Damp heat steady state (endurance)	5.6.2.3
Low humidity steady state (operational)	5.6.2.4
Shock (operational)	5.6.3.1
Impact (operational)	5.6.3.2
Vibration , sinusoidal (operational)	5.6.3.3

multi- sensor fire detectors - point detectors using a combination of smoke, carbon monoxide and heat sensors

Table 1 – Test schedule

Test	Clause
Vibration , sinusoidal (endurance)	5.6.3.4
Electrostatic discharge (operational) Radiated magnetic fields (operational) Conducted disturbances induced by electromagnetic fields (operational) Fast transient bursts (operational) Slow high energy voltage surge (operational)	5.6.4.1
Sulphur dioxide SO ₂ corrosion (endurance)	5.6.5.1
Exposure to high levels of carbon monoxide	5.6.5.2
Exposure to chemical agent at environmental concentrations.	5.6.5.3
Sensitivity to smoke	5.7.1
Sensitivity to carbon monoxide	5.7.2
Sensitivity to heat	5.7.3

^{a)} In the interests of test economy , it is permitted to use the same specimen for more than 1 EMC test. In that case intermediate functional test(s) on the specimen(s) used for more than one test can be deleted and the functional test conducted at the end of the sequence of tests. However it should be noted that in the event of a failure, it may not be possible to identify which test exposure caused the failure. (see EN 50130-4:2011, clause 4).

multi- sensor fire detectors point detectors using a combination of carbon monoxide and heat sensors

Annexe to EN54-31

Annexe A - Smoke tunnel for smoke response values

Annexe B - Test Aerosol for smoke detector response

Annexe C - Gas test chamber

Annexe D - Heat tunnel specification

Annexe E - Apparatus for Dazzling test

Annexe F - Measuring instruments for CO

Annexe G - Exposure level of chemical agents

Annexe H - Dazzling test

Annexe I - Impact test equipment

Annexe J - Fire test room

Annexe K Open wood fire (TF1)

Annexe L - Smouldering (pyrolosis) wood fire (TF2)

Annexe M - Glowing smouldering cotton fire (TF3)

Annexe N - Open plastic(polyurethane) fire (TF4)

Annexe O - Liquid (heptane) fire (TF5)

Annexe P - Low temperature black smoke(declane) liquid fire (TF8)

Annexe Q - Construction of the smoke tunnel

Annexe R - Construction of the gas test chamber

Annexe S - Construction of the heat tunnel

Annexe T - Test procedures and requirements for the response to slow developing fires

Annexe U - Construction and measurement of ionisation chamber

Annexe ZA - deals with the clauses of the standard in respect of their compliance with the mandate of the EU Construction product Regulation. (in planning).

electrical apparatus for potentially explosive atmospheres Intrinsic safety 'I'

BS EN 50020

Scope

This European standard was approved by CENELEC whose members are bound to comply. This gives this standard, with conditions, the status of a national standard.

The Standard specifies the construction and testing of intrinsically safe circuits, apparatus and associated apparatus for use in potentially explosive atmospheres. It applies to electrical apparatus in circuits which are safe and incapable of causing an explosion. The standard also applies to apparatus located outside the potentially hazardous area, or which are protected by another type of protection listed in EN 50014, where the intrinsic safety of the circuit may depend upon the apparatus itself.

Where intrinsically safe apparatus is required to be Category 1 G in accordance with EN 50284 it must also comply with the requirements in this standard.

Where it is required to be Category M1 equipment in accordance with EN 50303 it must also comply with the requirements of this standard.

Note: The former EN54 standard ceased to have harmonised status under the ATEX directive and was replaced by EN 60079-0. (Equipment in Explosive atmospheres). EN 50284 Equipment for use in Group II category 1G (general) EN50303 Equipment for use in Group I category M1 (mining)

Requirements

The requirements of this standard apply to both levels of Intrinsically safe apparatus protection "ia" and "ib", unless otherwise stated, and In the determination of the level, failure of components and connections shall be considered in accordance with 7.6.

When the maximum voltage is applied to the intrinsically safe circuits and apparatus of level "ia", it shall not be capable of causing ignition in normal operation when up to two countable and a number of none countable faults,

electrical apparatus for potentially explosive atmospheres Intrinsic safety 'I'

which present the most difficult conditions, are present.

When the maximum voltage is applied to the intrinsically safe circuits and apparatus of level "ib", it shall not be capable of causing ignition in normal operation when up to one countable and a number of none countable faults, which present the most difficult conditions, are present.

(Note: non countable faults are those in non-conforming components of the apparatus known as the associated apparatus; countable faults are those in components which conform to the constructional requirement of this standard, known as intrinsically safe apparatus. The application for ia covers all zones whereas ib devices are only approved for use in zone 1 and 2.

Simple apparatus can be defined as being a passive component such as a switch, or one where sources of stored energy are within defined parameters, for example capacitors, or where components can only generate very low

levels of energy, which is also within the defined parameters, for example photocells. When simple apparatus is located in the hazardous area, it shall be temperature classified.

Where simple apparatus is to be located in a Category 1 G or M1, then the apparatus shall also comply with the requirements of EN 50284 or EN 50303 as applicable.

Temperature classification, (T1-6) defines the maximum surface temperature of any surface exposed to the atmosphere and ensures it remains below the ignition temperature.

Intrinsically safe and associated apparatus require an adequate enclosure so as to secure the method of protection, which for Group II is IP20 in normally benign environments and for Group I is IP 54, in accordance with EN 60529, (degree of protection provided by enclosures).

electrical apparatus for potentially explosive atmospheres

Intrinsic safety 'I'

The maximum current in any insulated cable shall not exceed that specified by the manufacturer.

Terminals for intrinsically safe circuits shall be separated from non-intrinsically safe circuits including where intrinsic safety can be impaired by disconnected external wiring coming into contact with conductors or components. Terminals should be suitably arranged that components will not be damaged when connections are made and where separation is achieved by distance then the clearance between terminals shall ensure any bare conducting parts are at least 50mm apart and unlikely to come into contact, even if dislodged.

When separation is accomplished by locating terminals for intrinsically safe and non-intrinsically safe circuits in separate enclosures by use a partition and a single cover, the partitions separating terminals shall extend to within 1,5 mm of the enclosure walls, or shall provide a minimum distance of 50 mm between the bare

conducting parts of the external conductors. Metal partitions shall be earthed and have sufficient strength and rigidity to prevent any damage during the connection of field wiring. The clearance between the terminals of separate intrinsically safe circuits is given in Table 4 of the standard. In addition, the clearances between the bare conducting parts of connected external conductors shall be at least 6 mm and between any conducting parts of external conductors and earthed metal shall be 3 mm.

Plugs and sockets used for connection of external intrinsically safe circuits shall be separate from and non-interchangeable with those for non-intrinsically safe circuits.

Protection shall be provided within intrinsically safe apparatus to prevent the reversal of the polarity of supplies including within a battery where this could occur. For this purpose, a single diode shall be acceptable.

electrical apparatus for potentially explosive atmospheres Intrinsic safety 'I'

Where a relay coil is connected to an intrinsically safe circuit, the contacts in normal operation shall not exceed their manufacturer's rating and shall not switch more than 5 A. or 250 V or 100 VA. When the values exceed these but do not exceed 10 A or 500 VA, the values in Table 4 for the relevant voltage shall be doubled. For higher values, all circuits shall be connected to the same relay only if they are separated by a suitable earthed metal or insulating barrier. Where a relay has some contacts in intrinsically safe and others in non-intrinsically safe circuits, the contacts shall be separated by an insulating or earthed metal barrier in addition to Table 4. The relay shall be designed such that a broken or damaged contact cannot impair the integrity of the separation.

Where earthing of enclosures and equipment is required to maintain the type of protection (ia or ib), the cross-sectional area of any conductors, connectors and terminals used shall be rated to carry the maximum possible continuous current under the conditions specified

in clause 5. Components shall also conform to clause 7. Where a connector carries a conductor such as an earth connection on which intrinsic safety depends, the connector shall incorporate at least three independent connecting elements for "ia" circuits and two for "ib" circuits and be rated to carry the maximum possible current.

Where a casting compound is used to exclude a potentially explosive atmosphere from components and intrinsically safe circuits, it shall conform to 6.4.4, and where used to reduce the ignition capability of hot components its profile shall reduce the maximum surface temperature of the casting compound to the desired value.

In both normal operation and fault conditions, any remaining components on which the type of protection depends, shall not operate at more than two-thirds of their rating. These maximum rated values shall be the normal commercial ratings specified by the manufacturer of the component.

Connectors shall be designed such that

electrical apparatus for potentially explosive atmospheres

Intrinsic safety 'I'

interchangeability with others in the same apparatus is impossible unless it does not result in an unsafe condition or the connectors are easily identified.

Where an explosion could adversely affect intrinsic safety, the use of cells and batteries, capable of exploding, under certain conditions must be confirmed as being safe for use in intrinsically safe and associated apparatus for both ia and ib applications. They shall be of a type where leakage onto components is not possible and preferably should be sealed. Batteries which are not sealed shall be tested in accordance with 10.9.2

The diodes and resistors within a safety barrier limit the voltage and current applied to an intrinsically safe circuit. These assemblies are used as interfaces between intrinsically safe and non-intrinsically safe circuits, and shall be subjected to the routine test of 11.1. The requirements of Table 4 shall also apply except that lines 5, 6 and 7 do not apply to opto-coupled barriers; e.g. galvanic isolators. In addition to

any connection which may be at earth potential, the diode type barrier shall have a connection to earth through a 4mm(min) insulated wire.

Intrinsically safe and associated apparatus shall be marked in accordance with EN 50014.

For associated apparatus, the symbol EEx ia or EEx ib shall be enclosed in square brackets.

Connection facilities including terminal boxes, plugs and sockets shall be clearly marked and identifiable and where colour coded, it shall be light blue.

The documentation required by 23.2 of EN 50014 shall include the electrical parameters for the apparatus, power sources: output data; power receivers: input data, any special requirements for installation and use; the maximum voltage (ac/dc) which may be applied to non-intrinsically safe circuits or associated apparatus; special conditions relating to the type of protection, con-

electrical apparatus for potentially explosive atmospheres Intrinsic safety 'I'

formance or otherwise with insulation values (6.4.12); the designation of the surfaces of any enclosure where relevant to intrinsic safety and the environment for which the apparatus is suitable.

Appendix to EN50200

Annex A – Assessment of intrinsically safe circuits

Annex B – Spark test equipment

Annex C – Measurement of creepage, clearances and separation distances

Annex D – Encapsulation

Annex E – Certification for torches

fixed firefighting systems - components for gas extinguishing systems

EN 12094-1, Requirements and test methods for electrical automatic control and delay devices

Scope

This Standard specifies the requirements and test methods for electrical automatic control and delay devices (device) for use with automatic fire detection and fire alarm systems and CO₂-, Inert Gas- or Halocarbon Gas-Fire Extinguishing Systems. The standard specifies both compulsory and optional functions. Additional functions associated with fire extinguishing can be provided, but are not covered by this standard.

Requirements

The electric auto control and delay may be an independent unit or an integral part of a control and indicator panel. If the devices are integral to a control panel and use the same indication and controls as that as the fire detection and alarm system then the requirements for this standard and EN54-2

shall both be fulfilled. The power supply requirements shall be in accordance with EN54-4 and there shall be duplicate paths between the two if the power supply is not integral to the automatic control and delay device.

The functionality of the device shall be in accordance with clauses 4, 5, 6 and 9.3 of this standard. Testing is as detailed in section 9.

The device shall be classified for one of the following based upon the intended ambient conditions:

Class A: temperature range of - 5 °C to + 40 °C;

Class B: temperature range of - 20 °C to + 50 °C;

Class C: temperature range of - 5 °C to + 40 °C and corrosive atmosphere class 3C4 of EN 60721-3-3;

Class D: temperature range of - 20 °C to + 50 °C and corrosive atmosphere class 3C4 of EN 60721-3-3.

The device shall receive and process all the necessary functions associated

fixed firefighting systems - components for gas extinguishing systems

with the electrical control of the extinguishing system and indicate signals for each flooding zone, within 3 secs of the input being received. The compulsory functions to be performed by the device shall include receiving inputs from both the fire detection system and a manual station connected directly to the device. On receipts of input signals, a signal to the release mechanism and to a distinctive continuous alarm sounder, which shall only be silenced by an appropriate access level and after confirmation of a discharge occurring, shall occur within 1 further sec unless a delay is incorporated within the programme. The activation of an emergency hold button, will be displayed on the device, both audibly and visually, and if occurring during the pre-discharge warning time will affect a change to the signal from the alarm devices in the protected area. Faults affecting the emergency hold device shall be recognised and indicated within 2secs and prevent the transmission of the extinguishing signal. Any delay time shall be adjustable between 0 and 60 sec.

The device shall be capable of displaying all conditions including device activated, fault and extinguishing system gas released. The released condition can be established upon receipt of a signal indicating a flow of the gas, (both audibly and visually), or upon the triggering of the extinguishing signal output.

The monitoring of components such as a loss of gas will in the event of an abnormal condition indicate a fault, clearly displaying the nature of the condition and within 100s of its occurrence.

If a signal is sent to an external signalling unit, separate indication will be provided to that affect.

National guidelines can require other/different functionality, e.g. a separate indicator per flooding zone or a maximum number of monitored components per indicator.

Where an alphanumeric display is used to provide the required information, additional led's for the "Activated", "Re-

fixed firefighting systems - components for gas extinguishing systems

leased”, “Fault”, “Disabled” and “Blocked” conditions shall be provided.

The display should be capable of indicating all released flooding zones simultaneously. If it has insufficient numbers of fields the zones shall be indicated by separate light emitting indicators.

A field shall consist at least of 16 characters, where it cross refers to other information or 40 characters, where the display provides a full description.

Faults signals shall be displayed for any open, short circuit or earth fault associated with all input and output devices, including monitoring circuits, disablement devices, signal transmission equipment and power supplies, both AC and DC; or if there is a fault affecting the operating program in any software controlled device. In which case not more than one flooding zone shall be affected except where a room and its void are subdivided into two zones.

Optional functions which may be performed by the device can include, delaying the signal to the release mechanism whilst providing a distinct

intermittent pre-discharge warning, which shall not be interrupted, shortened or reset by a signal from the emergency hold button. To provide indication of a flow of agent together with the monitoring and control of valves and other associated components. If an emergency hold button is fitted it shall signal its status to the device together with any other mechanical parts capable of disabling the extinguishing system. The device shall receive and display any changeover from a manual to an automatic status.

If a controlled discharge of extinguishing agent is required this will be performed by the device as will the initiating of any secondary discharges. A secondary discharge will result from a second manual input, after the initial discharge and whilst the sounders in the area are still operating.

Signals to pilot cylinders, spare cylinders, optical devices, doors, ventilation plant, required as part of the cause and effect will be performed by the device. If the information is transmitted to an

fixed firefighting systems - components for gas extinguishing systems

external centre this shall be indicated by a separate light emitting indicator and/or by an alphanumeric display. If a device is intended to control the flooding time, it shall be adjustable from a minimum time specified by the manufacturer up to at least 300 s.

In some European countries there are regulations stipulating that the activated condition can only be established after the receipt of two input signals, from independent circuits, one from the fire detection and alarm system and a further signal from the device. The first input must be both audibly and visually indicated and outputs such as plant shutdown may be triggered. If the same indicator is used for both inputs, the first input shall be indicated with a flashing light, changing to a steady light when the second input is received.

The processing of the input signal shall have the highest priority unless a signal from an emergency hold or abort button is present; a fault exists within its circuit or if the gas discharge is disabled.

If the processing of the input signal has started, the disablement of any gas zone is prohibited.

Following a reset command the activated, released and fault conditions will be reset and the display will provide indication of the current status, including any not normal conditions, within 20 s. Provision shall be made to inhibit the reset, either for a period up to 30 seconds or until an end of discharge signal is received. Disablements shall not be removed by the reset function.

Annexes to EN12094-1

Annex A – Summary of Indications

Annex B – Software controlled device

Annex ZA - deals with the clauses of the standard in respect of their compliance with the mandate of the EU construction products regulation.

fixed firefighting systems - components for gas extinguishing systems

Part 3: Requirements and test methods for manual triggering and stop devices

Scope

This standard specifies the requirements and test methods for manual triggering and stop devices of CO₂-, Inert Gas- or Halocarbon Gas fire extinguishing systems.

Requirements

Electrical triggering devices shall comply, generally, with the requirements of EN 54-11 type B with clear indication of the function marked on the front face with "MANUAL RELEASE - Gas extinguishing system" (or in the national language(s) acceptable in the country of use). The colour of the component shall be yellow. A suitable yellow colour is specified in ISO 3864.

Electrical stop devices shall comply, generally, with EN 54-11 with clear indication of the function marked on the front face with "EMERGENCY STOP

- Gas extinguishing system", (or in the national language(s) acceptable in the country of use²). The colour of the component shall be blue. A suitable blue colour is specified in ISO 3864. Triggering and stop devices, which do not follow the design requirements of EN 54-11, shall have the same electrical function, performance and marking as specified above.

The pressurized parts of components, except seals, shall be made of metal with the working pressure specified by the manufacturer. The device will be marked as suitable for wall and/or machine mounting.

fixed firefighting systems - components for gas
extinguishing systems

**For triggering devices the tests shall be in accordance with EN 54-11
Non-electrical triggering devices - Test samples and order of tests**

Tests	Sub Clause
Compliance	5.2.3
Pressure	5.2.4
Strength	5.2.5
Function	5.2.6
Temperature	5.2.7
Operational reliability	5.2.8
Corrosion	5.2.9
Stress corrosion	5.2.10
Vibration	5.2.11

section two | an introduction to the suite of EN54 standards

fixed firefighting systems - components for gas extinguishing systems

Marking

Each component shall be marked in a permanent and legible manner with the name or logo of the manufacturer/supplier, the model (type / environment category as defined in EN 54-11, the installation detail, relevant data by which, at least, the date or batch and place of manufacture and the version number(s) of any software can be ascertained together with the working pressure for manual triggering devices and associated pipework.

Where the CE marking give the same information as above, the requirements of this clause 6 have been met.

Annex ZA - deals with the clauses of the standard in respect of their compliance with the mandate of the EU construction products regulation.





For more information about
FireClass fire detection technology visit:
www.fireclass.com
or contact us at
FireClasssales@tycoint.com

Issue 1.2 CGFC-02, 2019 EMEA Version
FireClass and any other product names listed above are marks and/
or registered marks. Unauthorized use is strictly prohibited.