

Fire NKF EN Diesel

Installation and operating instructions



EC Declaration of Conformity

We, Grundfos, declare under our sole responsibility that the product Fire NKF EN Diesel, to which this declaration relates, is in conformity with these Council Directives on the approximation of the laws of the EC Member States:

- Machinery Directive (2006/42/EC).
Standards used: EN 12100-1: 2003, EN 12100-2: 2003, EN 809: 1998.
- Low Voltage Directive (2006/95/EC).
Standards used: EN 60204-1: 2006, EN 61439-1: 2009.
- EMC Directive (2004/108/EC).
Standards used: EN 61000-6-2: 2005, EN 61000-6-3: 2007.

Wahlstedt, 1st April 2011

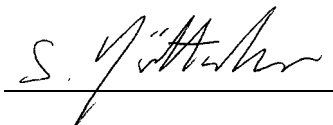

Stephan Götsche
General Manager
GRUNDFOS Pumpenfabrik GmbH
Willy-Pelz-Straße 1-5
23812 Wahlstedt, Germany

Person authorised to compile technical file and
empowered to sign the EC declaration of conformity.

CONTENTS

	Page		Page
1. Safety instructions	4	12. Operation	33
1.1 General	4	12.1 Automatic operation	34
1.2 Symbols used in this document	4	12.2 Manual operation	35
1.3 Personnel qualifications and training	4	12.3 Emergency	36
1.4 Risks of not observing the safety instructions	4	12.4 Test run	36
1.5 Safety-conscious working	5	13. Shutdown	38
1.6 Safety instructions for the operator	5	14. Maintenance	39
1.7 Safety instructions for maintenance, inspection and installation work	5	14.1 Maintenance intervals	39
1.8 Unauthorised modification and manufacture of spare parts	5	14.2 Sprinkler pump system	39
1.9 Improper operating methods	5	14.3 Sprinkler pump	39
2. Applications	5	14.4 Diesel engine	40
3. Delivery, transport, storage	5	14.5 Coupling	43
3.1 Delivery	5	14.6 Controller	43
3.2 Transportation	5	14.7 Batteries	43
3.3 Storage	6	15. Fault finding chart	44
4. Product description	6	16. Service, accessories, spare parts	46
4.1 Sprinkler pump system	6	17. Warranty	46
4.2 Sprinkler pump	8	18. Related documentation	46
4.3 Engine	8	19. Disposal	46
4.4 Controller	8	20. Appendix	47
4.5 Functions	10	20.1 Dimensions and weights	47
4.6 Factory settings	12	20.2 Engine data	48
5. Operating the controller	12		
5.1 Description of the control panel	12		
5.2 Menu structure	13		
5.3 Settings	14		
5.4 Operating and fault indications	16		
6. Product identification	19		
6.1 Nameplates	19		
6.2 Type Key	21		
7. Technical data	23		
7.1 Complete sprinkler pump system	23		
7.2 Sprinkler pump	23		
7.3 Diesel engine	24		
7.4 Controller	24		
7.5 Battery	24		
8. Operating conditions	25		
8.1 Maximum operating pressure	25		
8.2 Minimum inlet pressure	25		
8.3 Maximum permissible inlet pressure	25		
8.4 Minimum flow rate	25		
8.5 Pumped liquid	25		
8.6 Liquid and ambient temperature	25		
8.7 Relative air humidity	25		
8.8 Effect of ambient temperature and altitude on engine output	26		
9. Installation	26		
9.1 Location	26		
9.2 Foundation installation	26		
9.3 Vibration dampening	27		
9.4 Mounting the sprinkler pump system	27		
9.5 Pump/engine alignment	28		
9.6 Piping	29		
9.7 Priming tank and test pipe	29		
9.8 Bypass pipe	29		
9.9 Connecting the cooling system	29		
9.10 Exhaust system	30		
9.11 Separate fuel tank	30		
10. Electrical connection	31		
11. Commissioning	31		
11.1 Preparations before start-up	31		
11.2 Starting up the sprinkler pump system	32		
11.3 Checking the function	33		

1. Safety instructions

1.1 General

These installation and operating instructions contain general information that must be observed during installation and operation. It must therefore be read by the installer and the relevant qualified personnel/operator prior to installation and start-up. It must be available at the installation site of the sprinkler pump system at all times.

It is not only the general safety instructions given in this section that must be observed, but also the special safety instructions given in the other sections.

1.2 Symbols used in this document



Warning

If these safety instructions are not observed, it may result in personal injury.



Warning

If these instructions are not observed, it may lead to electric shock with consequent risk of serious personal injury or death.



Warning

The surface of the product may be so hot that it may cause burns or personal injury.



Warning

The sound pressure level is so high that hearing protection must be used. If this is not observed, deafness may result.

Caution

If these safety instructions are not observed, it may result in malfunction or damage to the equipment.

Note

Notes or instructions that make the job easier and ensure safe operation.

Safety instructions placed directly on the sprinkler pump system:



Warning

*The engine will start automatically!
Wear hearing protection!*



Warning

Do not remove safety devices!



Warning

Before start-up fill the engine with a cooling liquid consisting of a mixture of 50 % coolant and 50 % water.



Warning

In order to prevent damage, connect the cooling circuit before making the electrical connection of the cooling water heater.



Warning

*Do not let the engine run without an air filter.
Personal injury or damage to the engine may occur.*



Warning

This lifting point is only for lifting the engine, not the entire sprinkler pump system.



Lifting points for the entire sprinkler pump system.

The instructions below placed directly on the sprinkler pump system must be observed and must be legible at all times:

- direction of rotation arrow
- labelling of pipe connections
- stickers with safety instructions

1.3 Personnel qualifications and training

Operating, maintenance, inspection and installation personnel must have the relevant qualifications. The area of responsibility, level of authority and the supervision of the personnel must be precisely defined by the operator.

1.4 Risks of not observing the safety instructions

Non-observance of the safety instructions may have dangerous consequences for persons, the environment and the sprinkler pump system. If the safety instructions are not observed, all rights to claims for damages may be lost.

In detail, if safety instructions are not observed, this may cause the following damage for example:

- failure of important functions of the sprinkler pump system
- failure of specified methods for maintenance and servicing
- dangerous consequences to humans from exposure to electrical and mechanical impacts.

1.5 Safety-conscious working

The safety instructions described in these installation and operating instructions, existing national regulations for accident prevention and any internal working, operating and safety regulations of the operator must be observed.

1.6 Safety instructions for the operator

- Guards covering moving parts must not be removed when a sprinkler pump system is in operation.
- Prevent hazards caused by electrical energy (for details on this see e. g. in the provisions of the VDE and the local power supply companies).

1.7 Safety instructions for maintenance, inspection and installation work

The operator is responsible for ensuring that all maintenance, inspection and installation work is carried out by authorised and qualified personnel who have been adequately informed through careful examination of the installation and operating instructions.

Do not work on the sprinkler pump system when it is running. Observe the procedure described in the installation and operating instructions for stopping the system.

All safety and protective equipment must be refitted or activated directly after work is complete.

1.8 Unauthorised modification and manufacture of spare parts

Modification or changes to the sprinkler pump system are only permitted following agreement with the manufacturer. Original spare parts and accessories authorised by the manufacturer are safe to use. Using other parts can annul the liability for any resulting consequences.

1.9 Improper operating methods

The operational safety of the supplied sprinkler pump system is only guaranteed if it is used in accordance with section 2. *Applications* of the installation and operating instructions. The limit values specified in the technical data must never be exceeded.

2. Applications

The Grundfos Fire NKF sprinkler pump systems are designed for fire systems for supplying water to hose reels, fire hydrants and sprinkler systems.

Warning



The sprinkler pump systems must only be used for the applications mentioned. Any other use is considered improper. Grundfos cannot be held responsible for damage caused by improper use. The risk is carried solely by the operator.

In particular, the use of the Fire NKF EN diesel to supply water or boost pressure in daily operation is regarded as not in accordance with the intended use. The sprinkler pump systems are only intended and appropriately equipped for fire-fighting.

The control cabinet must not be misused to supply voltage to other devices either.

3. Delivery, transport, storage

Check the sprinkler pump systems carefully for transport damage and missing parts on delivery, and transport and store them correctly before installation.

Note

3.1 Delivery

The entire sprinkler pump system is delivered from factory in an open wooden box or in a closed box made of wood/plywood designed for transportation with forklift or pallet trucks.

3.2 Transportation

For lifting the entire fire sprinkler pump system, use the lifting eyes specifically marked on the base frame. When lifting, the lifting point should always be above the centre of gravity of the sprinkler pump system. See fig. 1.

Warning

When lifting the entire sprinkler pump system, never use the lifting eyes of the individual components.



Use only suitable lifting equipment in proper condition. See also the weight specifications in annex 20.1 Dimensions and weights.

The sprinkler pump system must only be transported when the cabinet door is closed and locked. Otherwise, there is a risk of jamming.

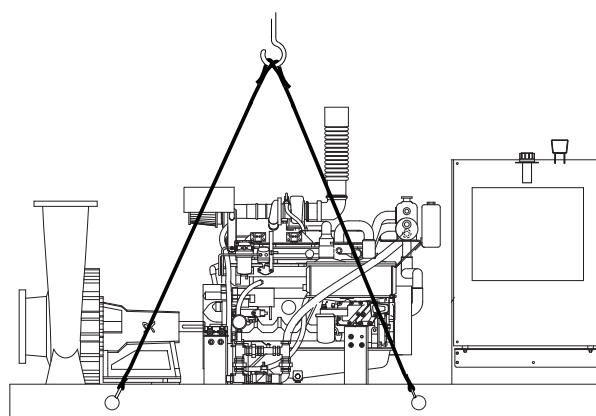

TM03 7770 4906

Fig. 1 How to lift the sprinkler pump system correctly

3.3 Storage

Note

The sprinkler pump system should be stored in a frost-free place in order to avoid corrosion and damage.

3.3.1 Sprinkler pump

Apply a suitable antirust agent on all machined, non-coated surfaces. If the sprinkler pump is to be stored for more than six months before start-up, the inner sprinkler pump components must be treated with a suitable antirust agent.

The antirust agent must meet these requirements:

- It must not attack rubber parts.
- It must be easy to remove.
- It must be applied in accordance with the manufacturer's instructions.

In order to prevent water, dust, etc. from penetrating the sprinkler pump, all openings must be covered appropriately until the pipes are installed. If this is not followed, it will be very expensive to dismantle the sprinkler pump to remove foreign bodies after commissioning.

Turn the pump shaft manually once a month to prevent the mechanical shaft seal from seizing up. To do this, the diesel engine must be isolated from the sprinkler pump.

See service manual, section 6.1 *CENTAFLEX Coupling*.

3.3.2 Engine

The diesel engines may be stored for up to 12 months in a dry room after delivery. We recommend protecting the engines with an air-permeable cover. Check at least once a month whether dirt or water deposits have formed. These must be removed immediately.

If the diesel engine is stored for more than 12 months or is decommissioned for more than 6 months, it must be protected from corrosion and damage as follows:

1. Drain the engine of oil, and replace the oil filter. Fill with MIL-L-21260 protective oil. See service manual, section 8.1.2 or 8.2.2 *Oil change with filter*.
2. Replace the fuel filter. See service manual, section 8.1.4 or 8.2.4 *Replacing the fuel filter*.
3. Separate the engine from the pump. See service manual, section 6.1 *CENTAFLEX Coupling*.
4. Turn on the engine. See section 12.2 *Manual operation*. Let the engine run for 1 to 2 minutes.
5. Drain oil and cooling liquid. See service manual, section 8.1.2 or 8.2.2 *Oil change with filter* and 8.1.3 or 8.2.3 *Changing the cooling liquid*.
6. Drain fuel. To do so, loosen the drain screw in the tank bottom (fig. 36) and collect the diesel fuel in a suitable container. After draining, tighten the drain screw in the tank bottom.
7. Place a warning label on the engine:
Engine without oil. Do not start the engine.

Repeat these steps every six months.

4. Product description

4.1 Sprinkler pump system

The complete sprinkler pump system consists of a sprinkler pump, a diesel engine and the controller. A flexible coupling connects sprinkler pump and diesel engine. All components are adapted to each other and mounted on a common base frame ready for installation. The base frame has holes for fastening lifting equipment and holes for attaching it to the floor.

The sprinkler pump system is delivered ready to use.

The fuel tank can be delivered separately in some options.

The installation and connection of fuel pipes must be carried out on site, see section 9.11 *Separate fuel tank*.

The most important components of the sprinkler pump system are, for example, shown in figs. 2 and 3.

An EN 12845-compliant Fire NKF diesel sprinkler pump system is shown with an NKF 80-250/255 Grundfos standard pump and a John Deere JU4H-NL34 diesel engine.

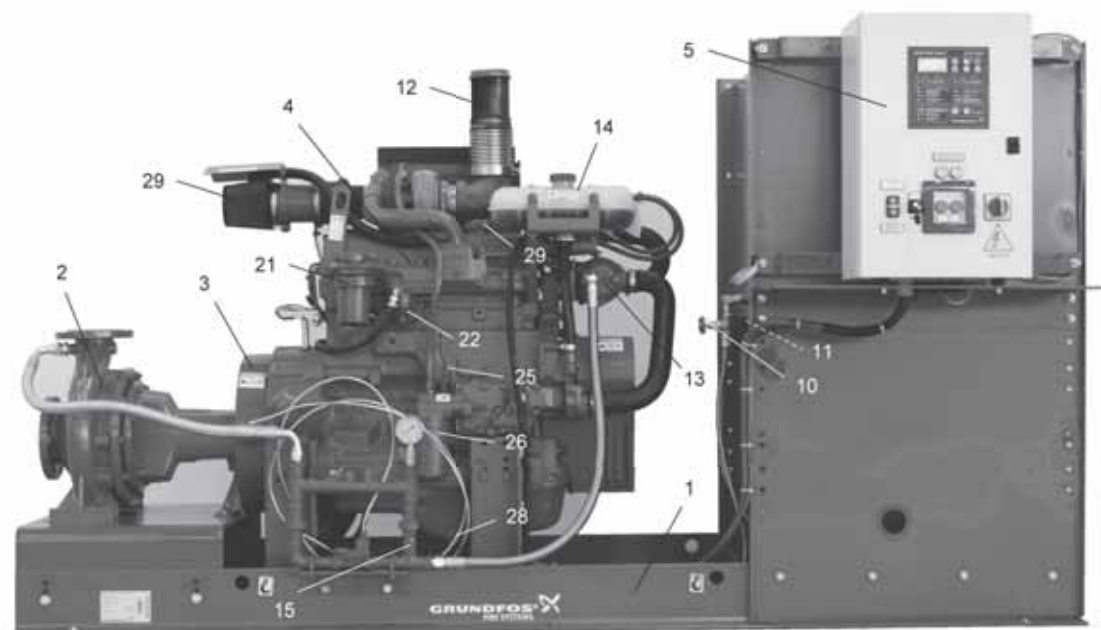

Fig. 2 Example of a Fire NKF EN diesel sprinkler pump system, front view

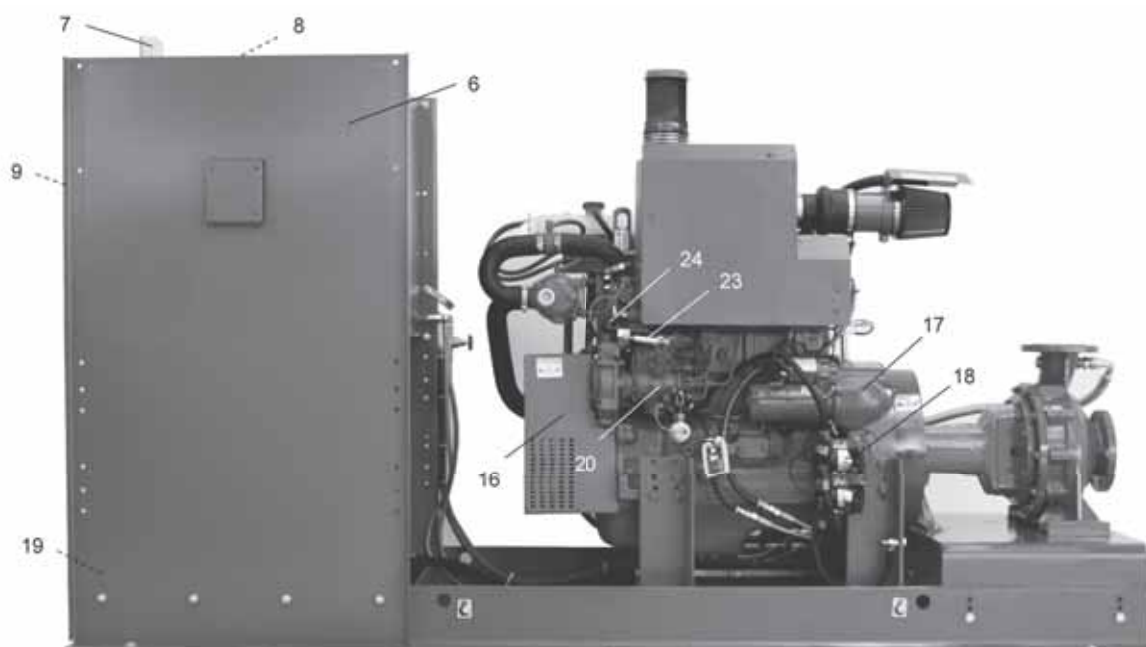

Fig. 3 Example of a Fire NKF EN diesel sprinkler pump system, rear view

Pos.	Component
1	Base frame
2	Pump
3	Coupling with coupling guard
4	Engine, complete
5	Controller
6	Fuel tank
7	Level gauge
8	Tank cap (hidden)
9	Manual filling pump (hidden)
10	Fuel cock
11	Drain screw on fuel tank (hidden)
12	Exhaust port
13	Heat exchanger
14	Equalisation vessel
15	Cooling circuit

Pos.	Component
16	Generator with V-belt and cover
17	Starter
18	Starter relay
19	Starter batteries (hidden)
20	Diesel injection pump
21	Fuel filter
22	Fuel delivery pump
23	Speed setting
24	STOP lever
25	Oil dipstick
26	Oil filter
27	Oil filler neck
28	Oil drain screw
29	Air filter
30	Cooling water heating (optional, not in the diagram)

TMO4 9838 0211

TMO4 9839 0211

4.2 Sprinkler pump

The sprinkler pumps of the sprinkler pump system are non-self-priming, single-stage Grundfos NKF standard pumps with volute casing. The sprinkler pumps have an axial suction port and a radial discharge port with PN 10 or PN 16 EN 1092-2-compliant flanges.

The impeller diameter can be reduced to customise the pump performance to a certain duty point. This means that the actual impeller diameter differs from the standard diameter stated in sales catalogues, data sheets, etc. The actual impeller diameter is stated on the sprinkler pump nameplate.

The NKF sprinkler pump is equipped with a rubber bellows seal, type BAQE, with seal faces of metal-impregnated carbon/silicon carbide. The elastomer parts are of EPDM.

Note *The sprinkler pumps meet the requirements defined in EN 12559-12.*

4.3 Engine

The sprinkler pumps are driven by a stationary 4-stroke diesel engine from John Deere or Lombardini which has been specially adjusted to the sprinkler pump drive requirements of Clarke UK Ltd.

The nominal engine power is adapted to the power requirement of the sprinkler pumps. The adjustment is made via the engine speed and consequently this must not be changed. The table shows the relationship between the diesel engines and the individual sprinkler pumps. Depending on performance, the engines have a turbocharger and, if necessary, also a charge air cooler.

Pump type	Engine type
NKF 32-200	LC2A-NL30
NKF 40-250	LC2A-NL30
	LC3A-NL30
	JU4H-NL14
NKF 50-200	LC2A-NL30
	LC3A-NL30
NKF 50-250	LC2A-NL30
	LC3A-NL30
	JU4H-NL14
NKF 65-160	LC3A-NL30
NKF 65-200	LC2A-NL30
	LC3A-NL30
	JU4H-NL14
NKF 80-200	JU4H-NL14
	JU4H-NL24
NKF 80-250	JU4H-NL14
	JU4H-NL24
	JU4H-NL34
NKF 100-200	JU4H-NL14
	JU4H-NL24
	JU4H-NL34
NKF 125-250	JU4H-NL54
	JU6H-NL34
	JU6H-NL74
	JU6H-NL84

Caution *The injection pump has been set from factory, and the setting must not be changed.*

The engine is cooled via a heat exchanger in the water-cooled John Deere engines. The cooling liquid is led to the heat exchanger via a pipe connected to the discharge port of the sprinkler pump. The discharge from the heat exchanger is via an open outlet according to EN 12845.

The Lombardini engines are air-cooled.

Note *The engines meet the requirements defined in EN 12845.*

4.4 Controller

4.4.1 General description

The sprinkler pump system is operated via a controller especially sized for diesel engines driving fire pumps. The purpose of the PLC controller is to start the sprinkler pump automatically and monitor the diesel engine.

As soon as the sprinklers are activated and water is consumed, the pressure in the discharge pipe is reduced. If the pressure becomes lower than the starting pressure set on the pressure switch, the sprinkler pump starts automatically via the pressure switch.

The sprinkler pump is stopped manually via the controller.

In addition to the pressure switch, always connect an extra pressure switch as in standard EN 12845.

Manual sprinkler pump operation is provided via a manual switch for commissioning, servicing and testing.

Note *The controller meets the requirements defined in EN 12845.*

4.4.2 Design

The controller is in a control cabinet mounted on the base frame. The controller is operated by means of the control panel and the manual switch in the cabinet door. The control cabinet powered from the mains supplies the engine with the power required for starting and operating the engine. The mains voltage is used to charge two extra starter batteries. Each starter battery is charged via its own charger. If the power supply fails, the two extra starter batteries take over the electrical supply of the control cabinet as well.

Control panel and gauges

All control elements and gauges are in the cabinet door. See fig. 4.

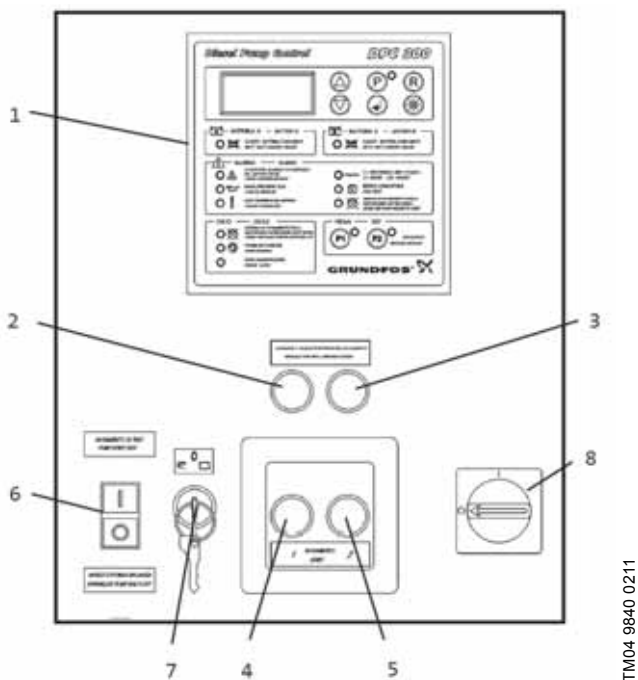

Fig. 4 Control elements in the cabinet door

Pos.	Description
1	PLC controller control panel
2	Test + activation of starting unit A with status display
3	Test + activation of starting unit B with status display
4	Activation of emergency start-up device A if controller fails
5	Activation of emergency start-up device B if controller fails
6	Sprinkler pump ON/OFF switch
7	Lockable selector switch (test - 0 - auto)
8	Main switch

The control elements have the following functions:

PLC controller control panel (pos. 1)

The PLC controller control panel contains the buttons required to parameterise the controller, a text display to display status and fault readings as well as various indicator lights.

The PLC controller control panel (pos. 1) is described in section 5.1 *Description of the control panel*.

Test pressure switch + starting unit activation (pos. 2 + 3)

The two pressure switches with integrated indicator lights act as an emergency start-up device for manual engine activation; if the engine does not start up after 6 automatic start attempts, see also section 12.3 *Emergency*. Each starting unit has its own pressure switch.

Pressure switch for emergency start-up device (pos. 4 + 5)

If the controller completely fails, the engine can still be activated via these two pressure switches arranged behind a glass panel, see also section 12.3 *Emergency*. Each starting unit has its own pressure switch.

ON/OFF switch (pos. 6)

The diesel engine can be started manually via the ON button, see section 12.2 *Manual operation*. The OFF button is used to switch off the diesel engine irrespective of whether start-up was manual or automatic, see section 12.1 *Automatic operation* and 12.2 *Manual operation*. You can only activate the button when the function selector is in the "test" position (pos. 7).

Function selector (pos. 7)

Select the operating mode (manual or automatic mode) by means of the selector switch. The selector switch must be shut off to prevent unauthorised activation.

Main switch (pos. 8)

The voltage supply to the control cabinet is switched on via the main switch.

Main components in control cabinet

The main components housed in the control cabinet are illustrated in fig. 5.

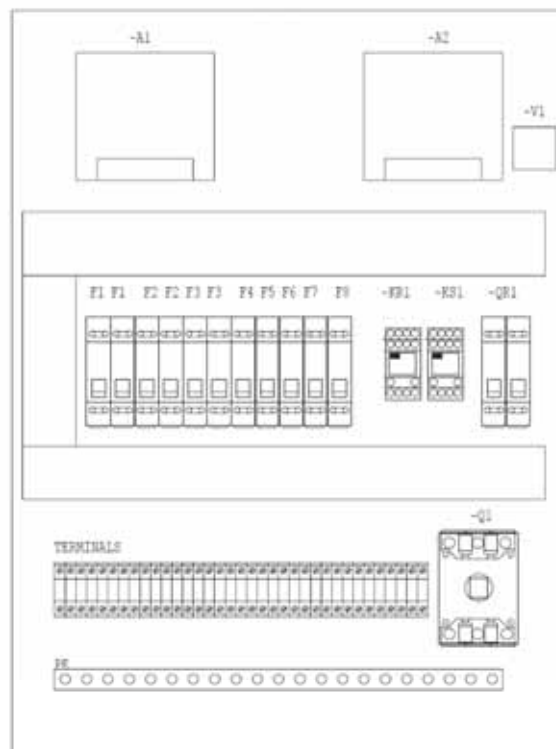

Fig. 5 Interior view of control cabinet

Pos.	Description
A1	Charger A
A2	Charger B
F1	Main fuse
F2	Fuse for charger A
F3	Fuse for charger B
F4	Fuse, battery A
F5	Fuse, battery B
F6	Fuse for the controller
F7	Fuse, emergency activation via battery A
F8	Fuse, emergency activation via battery B
KR1	Control relay, mains voltage available
KS1	Relay for external 12 V control voltage
PE	Protective conductor bar
Q1	Main switch
QR1	Automatic circuit breaker, pre-heating
V1	Diode bridge

TM04 9840 0211

4.4.3 Inputs and outputs

Inputs

The controller has 4 analog inputs and 7 monitored digital inputs.

Analog inputs

The following table shows the analog inputs together with the terminal marking and the assigned range of values.

Designation	Analog input	Terminal	Range of values	Corresponding resistance
AI1	Fuel level	63	0-100 %	350 - 0 Ω
AI2	Engine temperature	65	40-150 °C	1064 - 34 Ω
AI3	Oil pressure	64	0-80 bar	270 - 0 Ω
AI4	Speed sensor	61 + 62	-	-

Electrical data of analog inputs:

- Voltage class: none
- Insulation voltage: 50 V (in relation to earth)
- Insulation test voltage: none
- Input resistance: 1.5 kΩ
- Input resolution: 19.5 mV
- Accuracy at 25 °C: ± 0.4 %
- Resolution: 8 bit
- Integral time: 150 ms
- Reading interval: 40 ms

The analog inputs are not short-circuit proof.

The following data apply to the pulse input to which the speed sensor is attached:

- Maximum frequency: 10 KHz
- Input resistance: 4.85 kΩ
- Input voltage: 15 V
- Input current: 7 mA

Digital inputs

The following table shows the digital inputs together with the terminal marking and the status upon activation.

Designation	Digital input	Terminal	Upon activation
DI1	Pressure switch 1	81 + 82	open
DI2	Pressure switch 2	83 + 84	open
DI3	Level switch Priming tank (to start up the engine)	85 + 86	closed
DI4	Oil pressure switch (low oil pressure)	89 + 90	closed
DI5	Thermostat (high engine temperature)	91 + 92	closed
DI6	Pressure switch (pump delivers)	93 + 94	closed
DI7	Auxiliary input 1 (Aux. 1)	87 + 88	closed

Electrical data of digital inputs:

- Voltage class: none
- Insulation voltage: 50 V (in relation to earth)
- Insulation test voltage: none
- Output voltage: 12 V
- Input current: 8 mA
- Input filter time (software): 150 ms
- Input filter time (hardware): 20 ms.

The digital inputs are not short-circuit proof.

Outputs

The controller has 6 digital outputs executed as potential-free changeover contacts. The signals from the digital outputs can be passed on to a main controller.

Designation	Digital output	Terminal
AR1	Pump is running	30 - 33
AR2	Common fault	34 - 37
AR3	Function selector	38 - 40
AR4	Start Failure!	41 - 43
AR5	Controller fault	44 - 46
AR6	Auxiliary output 1 (Aux. 1)	47 - 49

Note

The output relay Aux. 1 (AR 6) is not wired internally and is consequently not used.

Electrical data of signal relay outputs:

- Voltage class: category 1
- Insulation voltage: 115 V (in relation to earth)
- Insulation test voltage: 1.5 kVAC
- Maximum supply voltage: 115 VAC
- Maximum load: 2 A, 115 V
- Minimum load: 100 mA, 12 VDC
- Maximum load power: 230 VA/24 W

4.5 Functions

The sprinkler pump system is controlled and monitored in accordance with the functions described below.

4.5.1 Operating functions

Automatic operation

Note

Automatic operation is the normal operating mode. For this mode, the selector switch (fig. 4, pos. 3) must be in the "AUTO" position.

If the pressure in the discharge pipe is reduced due to activation of the sprinklers, the diesel engine will be started via the pressure switch. The start-up attempt lasts 5-10 seconds. If the engine does not start up, another start-up attempt will be undertaken after 5-10 seconds. The duration of the start-up attempt and the time interval between two start-up attempts are adjustable. See section 5.3.6 *Start attempt interval* and 5.3.7 *Duration of start attempt*.

A maximum total of 6 start-up attempts are carried out. After each unsuccessful start attempt, a changeover between starter units will take place. After 6 unsuccessful start-up attempts, automatic mode is blocked by the controller and the "DIESEL FIRE PUMP FAILURE TO START" LED will light up in the controller control panel. Automatic standby is restored by pressing the reset button  on the control panel. See also section 12. *Operation*.

If the sprinkler pump system is in automatic mode, only the green "POWER SUPPLY" status LED will light up. The yellow "DIESEL FIRE PUMP STARTER SWITCHED OFF" status LED will not light up. If the sprinkler pump starts due to a request, the red "PUMP RUNNING" status LED will also light up. "AUT" is displayed as the reason for the start-up in accordance with the position of the selector switch, and the output relay AR1 will be activated.

During the start-up, the number of start-up attempts and the currently used starting unit (battery A or B) are also shown in the display.

You can only switch off the sprinkler pump manually by turning the selector switch (fig. 4, pos. 7) to "TEST" position and then pressing the OFF button of the ON/OFF switch (fig. 4, pos. 6).

Automatic mode is described in section 12.1 *Automatic operation*.

Manual operation

During commissioning or for test purposes, the sprinkler pump can be started manually by pressing the ON button of the ON/OFF switch (fig. 2, pos. 6) and thus bypassing the pressure switch in the discharge line, if the selector switch (fig. 2, pos. 7) was turned to "TEST" position beforehand. Keep the ON button pressed until the engine starts up. A start-up attempt should, however, not last longer than 15 seconds. The yellow "DIESEL FIRE PUMP STARTER SWITCHED OFF" status LED and the red "PUMP RUNNING" status LED will light up. "TEST" is displayed as the reason for the start-up in accordance with the position of the selector switch, and the output relays AR1 and AR3 will be activated.

The sprinkler pump is switched off via the OFF button of the ON/OFF switch (fig. 4, pos. 6). To restore automatic mode, the selector switch must be turned back to the "AUTO" position. Manual mode is described in section 12.2 *Manual operation*.

Emergency start-up device

The controller has an emergency start-up device, if starting the sprinkler pump in automatic mode has failed. The indicator lights integrated into the switches provided for starting in emergencies (fig. 4, pos. 2 and 3) will be on if it is possible to start via the emergency start-up device. The indicator lights will light up in the following cases:

- when the controller has been switched on for the first time
- when the engine has been started after an automatic start-up request and subsequently switched off via the OFF button of the ON/OFF switch (fig. 4, pos. 6)
- after six failed start attempts.

Checking the emergency start-up device is described in section 12.4 *Test run*.

If the controller fails (the "DIESEL CONTROLLER FAULT" LED lights up or the display and LEDs are off), the sprinkler pump can be started after smashing the glass and pressing the button behind it (fig. 4, pos. 4 and pos. 5).

Both emergency start-up devices are described in section 12.3 *Emergency*.

Checking the pressure switches

The pressure switch function can be checked by means of buttons P1 and P2 on the control panel. To do this, the selector switch (fig. 4, pos. 7) must be in the "TEST" position. During the checking procedure, the corresponding LED will light up alongside the respective button. The procedure is described in section 12.4 *Test run*.

Indicator light test

The controller enables an indicator light test to be carried out. To test the function of the LED, press the button .

Switching off fuel supply

When the sprinkler pump system is switched off, the controller automatically interrupts the fuel supply. Depending on the design, it is interrupted by switching off the voltage supply to the diesel injection pump or via a valve.

Calibration function

If necessary, the engine speed must be calibrated during commissioning. This will ensure that the correct speed is always shown in the display.

For calibration, see section 5.3.4 *Calibration of speed*.

Cooling water heater

Some sprinkler pump systems are equipped with a cooling water heater for the engine. A 10 A automatic circuit breaker and the required connection terminals (L2 and N2) are provided in the control cabinet to supply power to the cooling water heater. The heater adjusts itself via an external cooling water thermostat.

Operation and fault indications

The operation and fault indications are displayed on the control panel as text and via LEDs. See also section 5.4 *Operating and fault indications*. The most important fault readings can be forwarded to a master controller in the form of single indications or a collective alarm via output relay. The following faults are combined in one collective alarm:

- No mains voltage
- Defective battery/charger
- Oil pressure too low
- Engine temperature too high
- Fuel tank filling level too low
- Cooling water heater fuse has triggered.

The engine is not switched off when there are faults.

4.5.2 Monitoring functions

You will find an overview of the status and fault indications related to the monitoring functions in section 5.4 *Operating and fault indications*.

Monitoring of mains voltage

The voltage supply to the control cabinet is monitored by a relay. If the voltage supply is within the permitted range, the green "POWER SUPPLY" status LED on the control panel will be on. If the mains supply fails for more than 180 seconds, the green "POWER SUPPLY" status LED goes out and the reading "Power Supply!" will be displayed. Output relay AR2 is also deactivated for a collective fault. If the fault no longer exists, the fault indication will be reset automatically.

Monitoring of pump start/speed sensor

Check whether the sprinkler pump is running via the speed sensor. If the speed sensor sends a signal, the "PUMP RUNNING" LED will light up and output relay AR1 will be activated. The engine speed also appears in the display. If the speed sensor does not send a signal, "STOP" will be displayed instead of the speed. If the "STOP" reading does not disappear again after pressing the reset button , the speed sensor is defective.

Monitoring of batteries

Both battery sets (battery A, battery B) are monitored. If, for more than 30 seconds, the battery voltage is less than 9.6 V or more than 16.2 V or no battery is connected, the warning indication "Battery 1 Fault!" or "Battery 2 Fault!" will appear in the display for the battery concerned and the appropriate yellow LED "BATTERY A -> BATT./BATT. CHARGER FAILURE" or "BATTERY B -> BATT./BATT.CHARGER FAILURE" will light up. Output relay AR2 is also deactivated for a collective fault. The fault must be reset manually on the control panel by pressing the reset button .

Monitoring of chargers

Both chargers (for battery A and battery B) are monitored. If a charger does not work properly for more than 10 seconds, the warning "Charger 1 Fault!" or "Charger 2 Fault!" will appear in the display for the charger concerned and the appropriate yellow LED "BATTERY A -> BATT./BATT. CHARGER FAILURE" or "BATTERY B -> BATT./BATT. CHARGER FAILURE" will flash. Output relay AR2 is also deactivated in case of a collective fault. If the fault no longer exists, the fault indication will be reset automatically.

Monitoring of selector position

The sprinkler pump system is only ready for fire-fighting, if the selector is in "AUTO" position. This is why the position of the selector is monitored. If the selector is not in "Auto" position, but in "Test" position or "0", the yellow "DIESEL FIRE PUMP STARTER SWITCHED OFF" LED will light up and the appropriate output relay AR3 will be activated.

Monitoring of controller

The motherboard of the PLC controller is monitored. The yellow "DIESEL CONTROLLER FAULT" LED will light up on the control panel if there is a failure. Output relay AR 5 is activated at the same time. It is then still possible to start the sprinkler pump system by bypassing the PLC controller via the two buttons arranged behind the glass panel (fig. 4, pos. 4 and 5).

Oil pressure monitoring

The oil pressure is monitored via a pressure sensor on the diesel engine and is only active 60 seconds after the engine has been started. When oil pressure is too low, the yellow "LOW OIL PRESSURE" LED will light up on the control panel and the message "Low oil press.!" will appear in the display. Output relay AR2 is also deactivated for a collective fault. The fault must be reset manually by pressing the reset button  on the control panel.

Temperature monitoring

The temperature is monitored via a temperature sensor on the diesel engine and is only active 10 seconds after the engine has been started. When the permitted engine temperature is exceeded, the yellow "ENGINE OVERHEATED" LED will light up and the message "Motor temperat.!" will appear in the display. Output relay AR2 is also deactivated for a collective fault. The fault must be reset manually by pressing the reset button  on the control panel.

Monitoring of fuel tank filling level

If the filling level in the fuel tank falls below 70 % for more than 10 seconds, the yellow "FUEL STOCK" LED will light up and the message "Fuel Reserve!" will appear in the display. Output relay AR2 is also deactivated for a collective fault. If the filling level is above 75 %, the fault signal is reset automatically.

Monitoring of priming tank filling level

To monitor the filling level in the filling container, a level switch, such as a float switch, can be connected to the controller. If the level falls below the set filling level, e. g. as a result of leakages in the system, the engine will be started. A priming tank must e. g. be provided if there is negative inlet pressure or in other cases defined in EN 12845.

Monitoring of optional cooling water heater

The cooling water heater F1 fuse is monitored. After tripping the fuse, the "SC HEATER (OIL/WATER)" LED will light up and the message "Short-c- Heater!" will appear in the display. Output relay AR2 is also deactivated for a collective fault. If the fault no longer exists, the fault message is reset automatically.

Monitoring of external devices

It is possible to monitor an external device, such as a shut-off valve, via the controller. Use the corresponding digital input D17 for this. If the contact is closed, there will be an alarm reading in the display.

4.6 Factory settings

For the parameter values set by the factory in the PLC controller, see section 5.3 *Settings*.

5. Operating the controller

5.1 Description of the control panel

The control panel is used to set parameters, to display the operating status and alarm indications via the display and the LEDs as well as to reset alarms.

The control panel is divided into six areas (see fig. 6):

- Operating buttons with display
- Fault signal indicator, battery A
- Fault signal indicator, battery B
- Fault signal indicators, alarms
- Operating signal indicators
- Pressure switch testing.

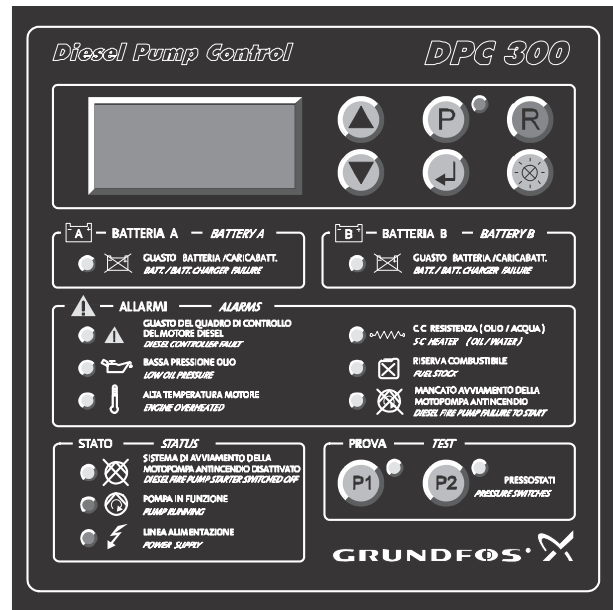

Fig. 6 PLC controller control panel

Display

The display shows the status with operating data and warning messages as well as the individual settings. The setting displays are described in section 5.3 *Settings* and the warning messages displayed in the lowest line of the status screen in section 5.4.2 *Fault indications*. Figure 7 shows the design of the status screen.

1700 rpm	AUT	->	Speed, calibration prompt or battery set and number of start attempts (to the left) and the cause for starting (to the right).
T = 40 °C	Oil = 10b	->	Engine temperature (°C) and oil pressure (bar)
00000H	Fuel = 100 %	->	Operating hours (H) and fuel level (%)
B1 = 24 V	B2 = 24 V	->	Voltage of battery A and B or warning indication

Fig. 7 Design of the status screen









Indicator lights

The meaning of the indicator lights is described in section 5.4 *Operating and fault indications*.

TM04 9842 0211

Operating buttons

The following table shows the function of the individual operating buttons.

Button	Function
 	Setting contrast Navigation between displays Changing parameter values
	Selecting parameterisation mode Exiting parameterisation mode
	Activating entry mode Storing parameter values
	Resetting alarms
	Indicator light test
	Checking the pressure switch function (pressure switch 1)
	Checking the pressure switch function (pressure switch 2)

5.2 Menu structure

The menu structure including the sequence of setting screens is illustrated below. Changing over from the status screen to the setting screens to launch the parameterisation process is described in section 5.3.1 *General procedure*.

Status	Setting
1700 rpm AUT T = 80 °C Oil = 3b 00000H Fuel = 100 % B1 = 12 V B2 = 12 V	Menu' Parameters Language German v
	Menu' Parameters Password 0 v
	Menu' Parameters Cal. Rev. Counter 1700 rpm v
	Menu' Parameters Cal. Motor ON No v
	Menu' Parameters Starting B1&B2 6 starts v
	Menu' Parameters Start Time OFF 7.0 s v
	Menu' Parameters Start Time ON 5.0 s v
	Menu' Parameters Stop Time 10 s

5.3 Settings

The following sub-sections firstly describe the general procedure and subsequently the setting of individual parameters.

5.3.1 General procedure

You should generally proceed as follows to change the parameter values:

1. Press to enter the parameterisation mode. The green LED next to will be on, and instead of the status display the first setting display will be shown.
2. Select setting display of the parameter to be changed using the button or .
3. Press in order to change the selected parameter. The green LED next to the button is flashing.
4. Change the value of the parameter by pressing the button or .
5. Press to store the parameter value. The green LED next to the button will be on.
6. To change further parameters, repeat steps 2 to 5.
7. Activate the changes and simultaneously return to the status display by pressing the button .

5.3.2 Setting of language

```
Menu' Parameters
Language
German
```

Via display "Language" one of these languages can be selected:

- German
- French
- English
- Italian
- Spanish.

Factory setting: German.

5.3.3 Entering of password

```
Menu' Parameters
Password
0
```

You can enter a password in this display. This enables access to other parameters, which must, however, only be changed by Grundfos employees.

5.3.4 Calibration of speed

If the controller is a component of a complete sprinkler pump system, the calibration to display the engine speed is carried out from factory. If the controller is delivered separately, a prompt for speed calibration will appear in the first line of the status display during the start-up:

```
?CAL?
T = 40 °C Oil = 10b
00000H Fuel = 100 %
B1 = 12 V B2 = 12 V
```

Calibration procedure:

1. Measure the operating speed directly at the engine with a suitable measuring device. Set the operating speed of the engine via the control rod on the injection pump to the next full hundred increment (e. g. 1700 rpm). To do this, loosen one of the lock nuts and turn the long nut either counter-clockwise (to increase the speed) or clockwise (to reduce the speed). Tighten the lock nuts after adjusting them.



Fig. 8 Control rod to set the engine speed

2. Press to enter the parameterisation mode. The green LED next to the button will be on.
3. Select the following setting display using the button or .

```
Menu' Parameters
Cal. Rev. Counter
1700 rpm
```

4. Press to change the speed. The green LED next to the button is flashing.
5. Change the speed with the button or (setting range 1000 to 4000 rpm, adjustable in increments of 100).
6. Press to store the parameter value. The green LED next to the button will be on.
7. Activate the changes and simultaneously return to the status screen by pressing the button .

After automatic calibration, the parameter value in the setting screen "Cal. Motor ON" is automatically reset to "No".

```
Menu' Parameters
Cal. Motor ON
No
```

The "?CAL?" symbol will be flashing in the display during the automatic calibration process. The calibration process can take up to 30 seconds. When the calibration process is completed, the current speed appears in place of the flashing symbol.

8. After calibration, the operating speed of the engine must be reset to the original nominal speed using the control rod of the injection pump.

5.3.5 Number of start attempts

Menu' Parameters
Starting B1&B2
6 starts

This display shows the number of start attempts. It is not possible to change the parameter value.

Factory setting: 6.

5.3.6 Start attempt interval



Menu' Parameters
Start Time OFF
7.0 s

In this display, the interval between two start attempts can be set for automatic operation.

Setting range: 5.0 to 10.0 s in increments of 0.1 s

Factory setting: 7.0 s

Note

In order to speed up the setting procedure, by keeping the button  and  pressed, the parameter value can also be changed into 1.0 second increments.

Note

In accordance with the provisions of EN 12845, the settings are only effective if the controller is connected to the mains for longer than 12 hours. Until then the time interval between two start attempts is always 11 seconds.

5.3.7 Duration of start attempt



Menu' Parameters
Start Time ON
5.0 s

In this display, the duration for which the starting relay is activated in order to start the engine can be set for automatic operation. The duration of the start attempt is thus specified.

Setting range: 5.0 to 10.0 s in increments of 0.1 s

Factory setting: 5.0 s

Note

In order to speed up the setting procedure, by keeping the button  and  pressed, the parameter value can also be changed into 1.0 second increments.

Note

In accordance with the provisions of EN 12845, the settings are only effective if the controller is connected to the mains for longer than 12 hours. Until then the duration for a start attempt is always 16 seconds.

5.3.8 Duration of stop attempt



Menu' Parameters
Stop Time
10 s

In this display, the duration for which the stop valve is activated in order to stop the engine when button S2 has been pressed.



Setting range: 5.0 to 25.0 s in increments of 0.1 s

Factory setting: 10 s

Note

In order to speed up the setting procedure, by keeping the button  and  pressed, the parameter value can also be changed into 1.0 second increments.

5.3.9 Change of contrast





The display contrast can be changed by pressing the button  (darker) or  (brighter).

5.4 Operating and fault indications

You will find an overview of the operation and fault alarms, which are also helpful in fault finding, in the following sub-sections.

5.4.1 Operating indications

The status appears as text in the display (see also section 5.1 *Description of the control panel*) and via LEDs. The following table gives an overview of status indications.









Status	LED		Display text in the status screen	Potential-free signalling	
	Status	Text			
The sprinkler pump system is in automatic mode and can start as required via the pressure switch or the level switch in the priming tank. The selector is in the "Auto" position.		off	DIESEL FIRE PUMP STARTER SWITCHED OFF	Motor OFF AUT T = 20 °C Oil = 0b 00000H Fuel = 100 % B1 = 12 V B2 = 12 V	AR3 not activated
The pump is running (automatic start via pressure switch or manual start). Whether the sprinkler pump was started manually or automatically is shown by stating the position of the selector on the right in the top line: AUT = Automatic operation TEST = Manual operation STOP = Switched off.		on	PUMP RUNNING	1700 rpm AUT T = 80 °C Oil = 3b 00000H Fuel = 100 % B1 = 12 V B2 = 12 V	AR1 activated
Mains voltage okay.		on	POWER SUPPLY	Motor OFF AUT T = 20 °C Oil = 0b 00000H Fuel = 100 % B1 = 12 V B2 = 12 V	
Calibration prompt (at start-up).	-	-	-	?CAL? T = 20 °C Oil = 0b 00000H Fuel = 100 % B1 = 12 V B2 = 12 V	
Engine start during automatic operation. Indication of battery set (B1), the number of start attempts (3) and the start trigger (AUT). (Between starts, the message "Engine OFF" is shown in the top line.)	-	-	-	Star. B1 = 3 AUT T = 20 °C Oil = 0b 00000H Fuel = 100 % B1 = 12 V B2 = 12 V	
Engine start during manual operation. (After starting up the diesel engine, the speed appears top left.)	-	-	-	Motor OFF TEST T = 20 °C Oil = 0b 00000H Fuel = 100 % B1 = 12 V B2 = 12 V	
Checking the function of pressure switch 1 is running.		on	PRESSURE SWITCHES	Motor OFF TEST T = 40 °C Oil = 3b 00000H Fuel = 100 % B1 = 12 V B2 = 12 V	
Checking the function of pressure switch 2 is running.		on	PRESSURE SWITCHES	Motor OFF TEST T = 40 °C Oil = 3b 00000H Fuel = 100 % B1 = 12 V B2 = 12 V	

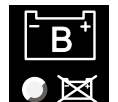
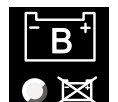

5.4.2 Fault indications

Fault indications are shown as warning message in the bottom line of the display and partly by means of LEDs in the control panel of the controller. Some warning messages are stored and must be reset manually by pressing the button  even if the fault no longer exists. Other warning messages are removed automatically when the fault is no longer present and require no resetting.

First the message "**** Alarm ****" is shown in the bottom line. Then the display with the warning message. After a certain interval (a few seconds), the message "**** Alarm ****" is shown again, followed by the next warning message.

For warning messages that apply to both pump ready for operation and to pump in operation, the table below shows the display of a pump ready for operation.

Fault	LED/indicator light		Display text (status screen)	Potential-free signalling	Reset									
	Status	Text												
Phase failure, no voltage supply.		off	POWER SUPPLY	<table border="1"> <tr> <td>Motor OFF</td> <td>AUT</td> </tr> <tr> <td>T = 20 °C</td> <td>Oil = 0b</td> </tr> <tr> <td>00000H</td> <td>Fuel = 100 %</td> </tr> <tr> <td colspan="2">Power Supply!</td> </tr> </table>	Motor OFF	AUT	T = 20 °C	Oil = 0b	00000H	Fuel = 100 %	Power Supply!			automatic
Motor OFF	AUT													
T = 20 °C	Oil = 0b													
00000H	Fuel = 100 %													
Power Supply!														
The sprinkler pump system is not in automatic mode. The selector is in "0" or "Test" position.		on		<table border="1"> <tr> <td>Motor OFF</td> <td>STOP</td> </tr> <tr> <td>T = 20 °C</td> <td>Oil = 0b</td> </tr> <tr> <td>00000H</td> <td>Fuel = 100 %</td> </tr> <tr> <td colspan="2">Function selector STOP!</td> </tr> </table>	Motor OFF	STOP	T = 20 °C	Oil = 0b	00000H	Fuel = 100 %	Function selector STOP!		AR3 activated	
Motor OFF	STOP													
T = 20 °C	Oil = 0b													
00000H	Fuel = 100 %													
Function selector STOP!														
Battery A: Battery voltage < 9.6 V Battery voltage > 16.2 V No battery connected		on	BATTERY A BATT./BATT. CHARGER FAILURE	<table border="1"> <tr> <td>Motor OFF</td> <td>AUT</td> </tr> <tr> <td>T = 20 °C</td> <td>Oil = 0b</td> </tr> <tr> <td>00000H</td> <td>Fuel = 100 %</td> </tr> <tr> <td colspan="2">Battery 1 Fault!</td> </tr> </table>	Motor OFF	AUT	T = 20 °C	Oil = 0b	00000H	Fuel = 100 %	Battery 1 Fault!		AR2 not activated	manual
Motor OFF	AUT													
T = 20 °C	Oil = 0b													
00000H	Fuel = 100 %													
Battery 1 Fault!														
Charger A: Low or no charging voltage.		flashing	BATTERY A BATT./BATT. CHARGER FAILURE	<table border="1"> <tr> <td>Motor OFF</td> <td>AUT</td> </tr> <tr> <td>T = 20 °C</td> <td>Oil = 0b</td> </tr> <tr> <td>00000H</td> <td>Fuel = 100 %</td> </tr> <tr> <td colspan="2">Charger 1 Fault!</td> </tr> </table>	Motor OFF	AUT	T = 20 °C	Oil = 0b	00000H	Fuel = 100 %	Charger 1 Fault!		AR2 not activated	automatic
Motor OFF	AUT													
T = 20 °C	Oil = 0b													
00000H	Fuel = 100 %													
Charger 1 Fault!														
Battery B: Battery voltage < 9.6 V Battery voltage > 16.2 V No battery connected		on	BATTERY B BATT./BATT. CHARGER FAILURE	<table border="1"> <tr> <td>Motor OFF</td> <td>AUT</td> </tr> <tr> <td>T = 20 °C</td> <td>Oil = 0b</td> </tr> <tr> <td>00000H</td> <td>Fuel = 100 %</td> </tr> <tr> <td colspan="2">Battery 2 Fault!</td> </tr> </table>	Motor OFF	AUT	T = 20 °C	Oil = 0b	00000H	Fuel = 100 %	Battery 2 Fault!		AR2 not activated	manual
Motor OFF	AUT													
T = 20 °C	Oil = 0b													
00000H	Fuel = 100 %													
Battery 2 Fault!														
Charger B: Low or no charging voltage.		flashing	BATTERY B BATT./BATT. CHARGER FAILURE	<table border="1"> <tr> <td>Motor OFF</td> <td>AUT</td> </tr> <tr> <td>T = 20 °C</td> <td>Oil = 0b</td> </tr> <tr> <td>00000H</td> <td>Fuel = 100 %</td> </tr> <tr> <td colspan="2">Charger 2 Fault!</td> </tr> </table>	Motor OFF	AUT	T = 20 °C	Oil = 0b	00000H	Fuel = 100 %	Charger 2 Fault!		AR2 not activated	automatic
Motor OFF	AUT													
T = 20 °C	Oil = 0b													
00000H	Fuel = 100 %													
Charger 2 Fault!														
Controller failure.		on	DIESEL CONTROLLER FAULT	-	AR5 not activated									
Oil pressure too low (only when engine is running).		on	LOW OIL PRESSURE	<table border="1"> <tr> <td>1700 rpm</td> <td>AUT</td> </tr> <tr> <td>T = 80 °C</td> <td>Oil = 1b</td> </tr> <tr> <td>00000H</td> <td>Fuel = 100 %</td> </tr> <tr> <td colspan="2">Low Oil Press. !</td> </tr> </table>	1700 rpm	AUT	T = 80 °C	Oil = 1b	00000H	Fuel = 100 %	Low Oil Press. !		AR2 not activated	manual
1700 rpm	AUT													
T = 80 °C	Oil = 1b													
00000H	Fuel = 100 %													
Low Oil Press. !														
Cooling water temperature too high (only when engine is running).		on	ENGINE OVERHEATED	<table border="1"> <tr> <td>1700 rpm</td> <td>AUT</td> </tr> <tr> <td>T = 100 °C</td> <td>Oil = 3b</td> </tr> <tr> <td>00000H</td> <td>Fuel = 100 %</td> </tr> <tr> <td colspan="2">Motor Temperat.!</td> </tr> </table>	1700 rpm	AUT	T = 100 °C	Oil = 3b	00000H	Fuel = 100 %	Motor Temperat.!		AR2 not activated	manual
1700 rpm	AUT													
T = 100 °C	Oil = 3b													
00000H	Fuel = 100 %													
Motor Temperat.!														

Fault	LED/indicator light		Display text (status screen)	Potential-free signalling	Reset	
	Status	Text				
Cooling water heater defective.		on	SC HEATER (OIL/WATER)	Motor OFF AUT T = 20 °C Oil = 0b 00000H Fuel = 100 % Short-c- Heater	AR2 not activated	automatic
Low filling level in the fuel tank (filling level < 70 %).		on	FUEL STOCK	Motor OFF AUT T = 20 °C Oil = 0b 00000H Fuel = 20 % Fuel Reserve!	AR2 not activated	automatic
Six failed start attempts in automatic mode.		on	DIESEL FIRE PUMP FAILURE TO START	Motor OFF AUT T = 20 °C Oil = 0b 00000H Fuel = 100 % Start Failure!!	AR4 activated	manual
Speed sensor fault (when engine is running).	-	-	-	STOP AUT T = 80 °C Oil = 3b 00000H Fuel = 100 % Re. Counter Sen.!		manual
External device fault.	-	-	-	Motor OFF AUT T = 20 °C Oil = 0b 00000H Fuel = 100 % Auxiliary Fault		manual

6. Product identification

6.1 Nameplates

All important data of the sprinkler pump system is on the sprinkler pump system nameplate (fig. 9), the nameplate of the engine (fig. 10), the nameplate of the sprinkler pump (fig. 11) and the nameplate of the controller (fig. 12).

Sprinkler pump system nameplate

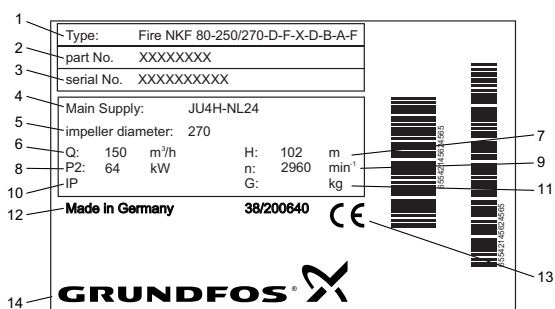

Fig. 9 Fire NKF sprinkler pump system nameplate

Pos.	Description
1	Type designation
2	Product number
3	Serial number
4	Engine type for pump drive
5	Impeller diameter
6	Flow rate Q in m³/h
7	Head H in m
8	Engine power P2 in kW
9	Rated speed n in rpm
10	Protection class
11	Weight
12	Country of origin
13	CE mark
14	Manufacturer

The nameplate of the complete sprinkler pump system is attached to the base frame.

Engine nameplate

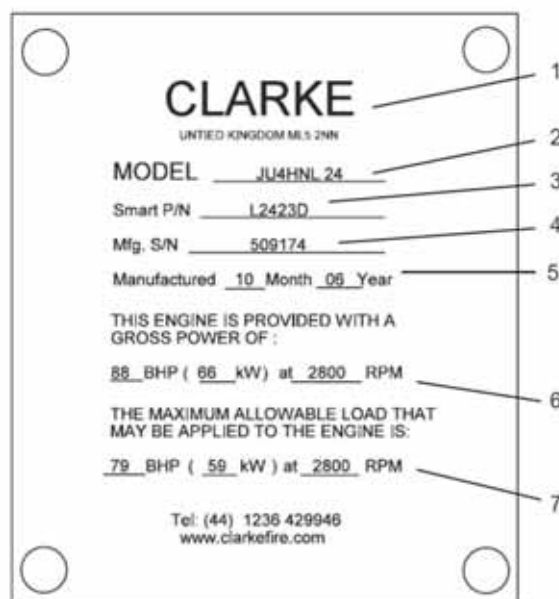
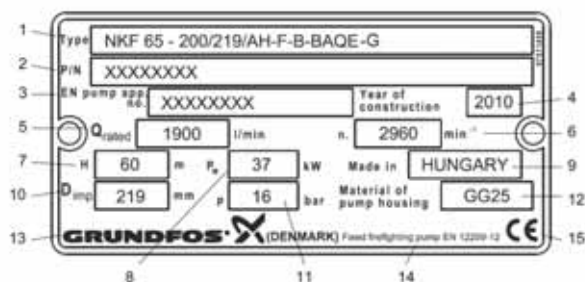

Fig. 10 Nameplate of engine

Pos.	Description
1	Manufacturer
2	Type designation
3	Product number
4	Serial number
5	Date of manufacture
6	Max. permitted power and speed
7	Rated power and speed

The nameplate of the diesel engine is attached to the housing of the flywheel.

Sprinkler pump nameplate



TM04 9846 0211

Fig. 11 Nameplate of a sprinkler pump

Pos.	Description
1	Type designation
2	Product number
3	EN approval number
4	Production year
5	Rated flow rate Q in l/min
6	Rated speed n in rpm
7	Head H in m
8	Rated engine power in kW
9	Country of origin
10	Impeller diameter (mm)
11	Max. permitted operating pressure (bar)
12	Pump housing material
13	Manufacturer
14	Sprinkler pump in accordance with EN 12259-12
15	CE mark

The nameplate of the sprinkler pump is attached to the bearing bracket of the pump.

Controller nameplate

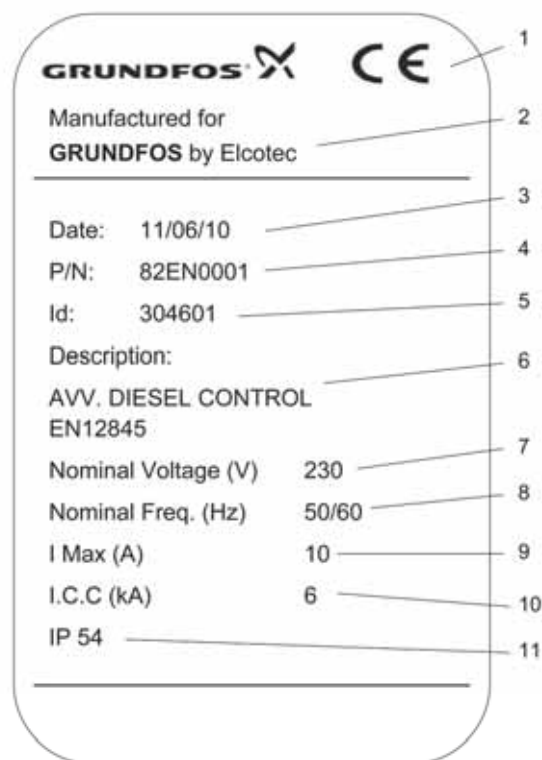

TM04 9847 0211

Fig. 12 Nameplate of the controller

Pos.	Description
1	CE mark
2	Manufacturer
3	Production date
4	Product number
5	Serial number
6	Type designation
7	Nominal voltage
8	Nominal frequency
9	Max. current
10	Rated short circuit current
11	Protection class

The nameplate of the controller is attached externally on the right side and internally on the cabinet door.

6.2 Type Key

The sprinkler pump system can be clearly identified via the type designation stated on the nameplate of the sprinkler pump system (fig. 9, pos. 1). The type key underlying the type designation is described below. The type keys of the diesel engine and the sprinkler pump required to obtain spare parts are also described.

Type key of the sprinkler pump system

Example:	Fire	NK	F	80	-250	/270	D	G	X	D	B	A	F
Fire: Sprinkler pump system													
Pump type													
F: Pump approved for fire-fighting													
Nominal diameter of discharge port [mm]													
Pump housing size [mm]													
Actual impeller diameter [mm]													
Driver D: Diesel engine E: Electric motor, 50 Hz													
Approvals of the sprinkler pump F: VdS G: EN standard													
Approvals of the sprinkler pump system X: No specific approval													
Pipe connections D: DIN flange													
Contoller with control panel B: for mounting on base frame W: for wall mounting X: without controller													
Shaft seal A: BAQE													
Coupling A: Standard coupling B: Spacer coupling F: Centaflex coupling													

The example shows an EN 12845-compliant Fire NKF 80-250 sprinkler pump system, with the following components:

- 270 mm impeller
- BAQE mechanical shaft seal
- Diesel engine drive
- Pump with DIN flanges
- Controller mounted on base frame
- Flexible coupling.

Type key of the engine**Example:** J U 4 H -NL 24**Engine type**

J: John Deere basic engine adapted by CLARKE UK LTD
 L: Lombardini engine

Engine series

C: Basic series of Lombardini engines
 U: Basic series of John Deere engines
 4-cylinder engine = 4.5 litres
 6-cylinder engine = 6.8 litres

Number of cylinders

2: 2 cylinders
 3: 3 cylinders
 4: 4 cylinders
 6: 6 cylinders

Cooling

A: Air cooling
 H: Heat exchanger

Approvals of engine

NL: not listed

Code for rated power

The example shows a non-listed John Deere basic line engine with a 4.5-litre engine displacement. Cooling takes place via a heat exchanger.

Type key for the sprinkler pump**Example** NKF 65-200 /219 AH -F -B -BAQE -G**Type range**

NKF = standard NK pump for sprinkler pump systems

Nominal diameter of pump discharge port

65 mm

Nominal impeller diameter

200 mm

Actual diameter of the impeller

219 mm

Code for pump version

AH: NKF sprinkler pump with free shaft end
 A2: Basic NKF version with spacer coupling

Code for pipe connection

F: DIN flange

Code for materials

B: Bronze impeller EN-GJL-250

Codes for shaft seal and elastomer pump components**Pump approval**

G: EN

The example shows an EN 12259-12-compliant NKF 65-200 sprinkler pump, with the following components:

- 219 mm bronze impeller
- BAQE mechanical shaft seal
- DIN flange
- Cast iron housing
- Standard coupling.

The mechanical shaft seal used is fully described via its type code, see the following table.

Position	Code	Description
1	B	Rubber bellows seal
Position	Code	Sliding surface material
2 and 3	A	Metal-impregnated carbon
	Q	Silicon carbide
Position	Code	Elastomer component material
4	E	EPDM

7. Technical data

7.1 Complete sprinkler pump system

Dimensions: see section 20.1 *Dimensions and weights*

Weight: see nameplate

Sound pressure level

Designation	Engine type	Sound pressure level
Fire NKF 32-200	LC2A-NL30	97.2 dB(A)
	LC3A-NL30	
Fire NKF 40-250	LC2A-NL30	97.2 dB(A)
	JU4H-NL14	
Fire NKF 50-200	LC2A-NL30	97.2 dB(A)
	LC3A-NL30	
Fire NKF 50-250	LC2A-NL30	97.2 dB(A)
	LC3A-NL30	
	JU4H-NL14	
Fire NKF 65-160	LC3A-NL30	97.2 dB(A)
Fire NKF 65-200	LC2A-NL30	
	JU4H-NL14	
Fire NKF 80-200	JU4H-NL14	97.2 dB(A)
	JU4H-NL24	97.2 dB(A)
Fire NKF 80-250	JU4H-NL14	97.2 dB(A)
	JU4H-NL24	97.2 dB(A)
	JU4H-NL34	98.1 dB(A)
Fire NKF 100-200	JU4H-NL14	97.2 dB(A)
	JU4H-NL24	97.2 dB(A)
	JU4H-NL34	98.1 dB(A)
Fire NKF 125-250	JU4H-NL54	98.1 dB(A)
	JU6H-NL34	98.7 dB(A)
	JU6H-NL74	98.8 dB(A)
	JU6H-NL84	98.8 dB(A)

The sound pressure level was measured without a silencer 1 metre away from the sprinkler pump system.

Note

The silencer supplied is designed for the requirements of the industrial market. If you have higher noise level requirements, you have the option of ordering and installing another silencer.

Warning



The sound pressure level when the engine is running is >70 dB(A). Hearing protection must therefore definitely be worn when working on or near the engine.

7.2 Sprinkler pump

Dimensions: see section 20.1 *Dimensions and weights*

Weight: see section 20.1 *Dimensions and weights*

Flow rate: see nameplate

Total head: see nameplate

Pressure stage: PN 16

Permitted flange forces and flange torques

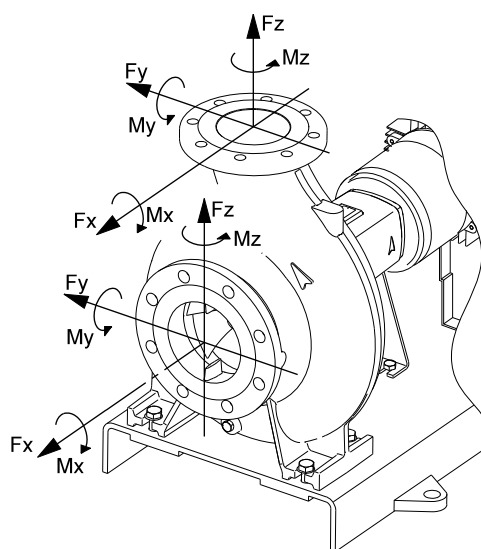

TM04 5621 3609

Fig. 13 Definition of flange forces and torques

Grey cast iron	Diameter DN	Forces [N]			
		Fy	Fz	Fx	ΣF*
Horizontal pump z-axis discharge port	32	315	298	368	578
	40	385	350	438	683
	50	525	473	578	910
	65	648	595	735	1155
	80	788	718	875	1383
Horizontal pump x-axis suction port	100	1050	945	1173	1838
	125	1243	1120	1383	2170
	50	578	525	473	910
	65	735	648	595	1155
	80	875	788	718	1383
	100	1173	1050	945	1838
	125	1383	1243	1120	2170
	150	1750	1575	1418	2748

Grey cast iron	Diameter DN	Torques [Nm]			
		My	Mz	Mx	ΣM*
Horizontal pump z-axis discharge port	32	263	298	385	560
	40	315	368	455	665
	50	350	403	490	718
	65	385	420	525	770
	80	403	455	560	823
Horizontal pump x-axis suction port	100	438	508	613	910
	125	525	665	785	1068
	50	350	403	490	718
	65	385	420	525	770
	80	403	455	560	823
	100	438	508	613	910
	125	525	665	785	1068
	150	613	718	875	1278

* ΣF and ΣM are the vector sums of the forces and torques.

If not all loads reach the maximum permissible value, one of these values may exceed the normal limit. For further information, please contact Grundfos.

7.3 Diesel engine

Design:	4-stroke diesel engine
Performance:	see 20.2 <i>Engine data</i>
Speed:	see 20.2 <i>Engine data</i>
Weight:	see 20.1 <i>Dimensions and weights</i>
Diameter of exhaust pipe:	see 20.1 <i>Dimensions and weights</i>
Discharge heat exchanger:	1" or 1¼" depending on the version
Quantity of oil:	see 20.2 <i>Engine data</i>
Type of oil:	API classification CF4 Viskosität: 15 W-40



Warning

In the running-in period, use "John Deere Break-in" oil (TY22041) for refilling.

Oil pressure:	see 20.2 <i>Engine data</i>
Amount of cooling liquid:	see 20.2 <i>Engine data</i>
Cooling liquid:	Mixture of 50 % coolant (ethylene/glycol according to ASTM D4985) and 50 % water.



Warning

Never use conventional coolant for vehicle engines. They can damage the engine due to their high silicate content!

Coolant temperature:	71 to 93 °C
Fuel quantity:	see 20.2 <i>Engine data</i>

Note

The size of the fuel tank allows the pump unit to operate for six hours without interruption.

Fuel type:	Diesel in accordance with ASTM D-975 No. 2-D Diesel in accordance with BS 2869, class A2
------------	---



Warning

Do not use bio diesel, particularly due to its inadequate storage and corrosion properties.

Permissible exhaust counter-pressure:	LC2A: 0.05 bar LC3A: 0.05 bar JU4H: 0.075 bar JU6H: 0.075 bar
---------------------------------------	--

7.4 Controller

Control cabinet:	Sheet steel, grey
Enclosure class:	IP 54
Dimensions (W x H x D):	400 x 600 x 250 [mm]
Weight:	appr. 50 kg
Supply voltage:	1 x 230 V, 50 Hz, N + PE
Max. power consumption:	100 W without cooling water heater 1100 W mit Kühlwasserheizung
Max. current consumption:	10 A
Connecting terminals:	L1, N = 2.5 - 6 mm ²
EMC noise emission:	according to EN 61000-6-3
EMC noise immunity:	according to EN 61000-6-2
Overvoltage category:	III
Rated surge voltage:	6 kV
Rated short circuit current:	6 kA
Degree of contamination:	2
Ambient temperature:	4-40 °C
Country of origin:	Italy

7.5 Battery

Type:	see table
Number:	1 per starter set
Voltage:	12 V
Capacity:	see table
Dimensions (L x W x H):	see table
Weight:	appr. 38 kg

Engine type	Battery type	Capacity [Ah]	Dimensions [mm]		
			L	B	H
LC2A	CLT 55-12	55	228	137	207
LC3A	CLT 55-12	55	228	137	207
JU4H	CLT 55-12	55	228	137	207
JU6H	CLT 70-12	70	350	167	179

8. Operating conditions



Warning

The operating conditions stated in the following sub-sections must be observed. Operation outside the given range is not safe.

8.1 Maximum operating pressure

The NKF sprinkler pumps are designed for a maximum operating pressure of 16 bar.

8.2 Minimum inlet pressure

The minimum inlet pressure "H" in m, required during operation to avoid cavitation in the sprinkler pump, can be calculated by means of the following equation:

$$H = p_b \times 10.2 - NPSH - H_f - H_v - H_s$$

p_b	Barometric pressure in bar. (The barometric pressure can be set to 1 bar.) In closed systems, p _b is equal to the system pressure in bar.
NPSH	NPSH value in m (to be read from the NPSH curve at the maximum flow rate point). The NPSH value can be taken from the characteristics in the appropriate data booklet (publication number 97641687).
H_f	Friction loss in the suction line in m.
H_v	Steam pressure in m, with t _m = liquid temperature (fig. 14).
H_s	Safety margin = minimum 0.5 m.

If the value determined for H is positive, the sprinkler pump can be operated at a maximum suction lift of "H" metres.

If the value determined for H is negative, a minimum inlet pressure of "H" metres is required.

The value calculated for H must be at the suction port of the sprinkler pump.

Relation between steam pressure scale and liquid temperature t_m

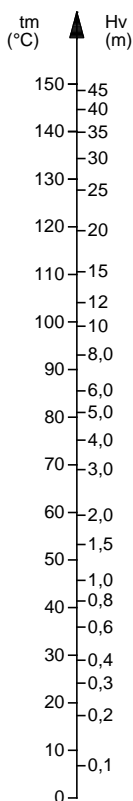

Fig. 14 Steam pressure scale

8.3 Maximum permissible inlet pressure

The sum of actual inlet pressure plus sprinkler pump pressure against a closed valve must always be lower than the maximum permissible operating pressure, see section 8.1 *Maximum operating pressure*. The closed valve pressure for the sprinkler pump concerned can be taken from the appropriate data booklet (publication number 97641687).

8.4 Minimum flow rate



Warning

The sprinkler pump is not allowed to run against a closed valve as this may cause an unacceptable temperature increase or the formation of steam. This may cause damage to the sprinkler pump.

Install a bypass pipe to ensure a minimum flow rate equal to 10 % of the flow rate at maximum efficiency. The minimum flow rate helps to dissipate any excessive heat and thus protect the sprinkler pump from overheating.

8.5 Pumped liquid

The sprinkler pump is suitable for pumping clean and non-aggressive fire extinguishing water, not containing additives.

8.6 Liquid and ambient temperature

Liquid temperature

Max. permitted liquid temperature: 40 °C

The maximum permitted liquid temperature is decided by the coolant temperature required to cool the diesel engine.

The sprinkler pump itself is designed for liquid temperatures up to 120 °C.

Minimum permissible ambient temperature

- +4 °C, if the engine includes preheating
- +10 °C, if the engine does not include preheating

Maximum permissible ambient temperature

The maximum ambient temperature at the air filter inlet of the diesel engine is 40 °C. A maximum permissible ambient temperature of 40 °C also applies to the controller.

8.7 Relative air humidity

The relative air humidity must not be too high to prevent condensation of moisture in the air. This can lead to damage of the controller or the engine. If humidity is a problem, install a space heater with a hydrostat.

TM00 3037 0798

8.8 Effect of ambient temperature and altitude on engine output

If the ambient temperature exceeds +25 °C (fig. 15) or if the engine is installed more than 100 m above sea level (fig. 16), the engine must not be operated at full capacity. In these cases, it may be necessary to use a larger engine.

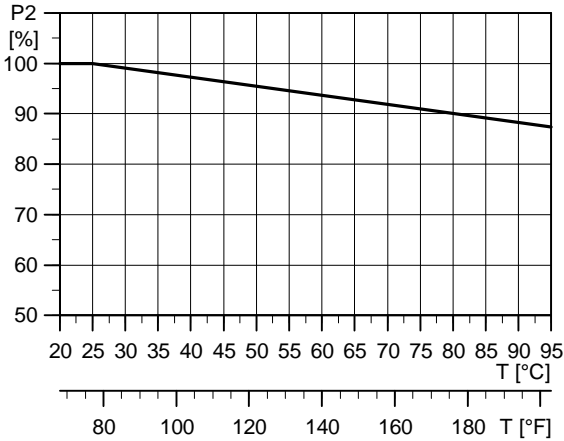

Fig. 15 Relation between engine output P2 and ambient temperature

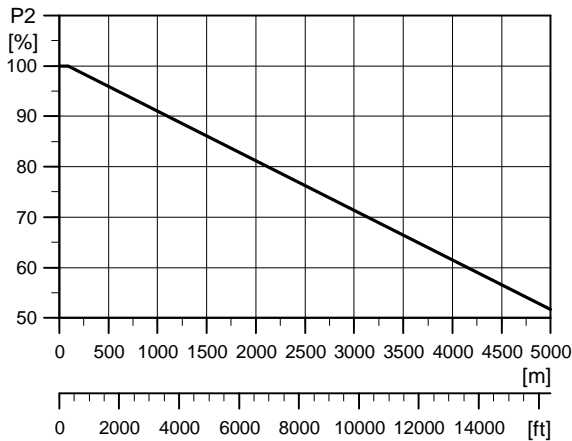

Fig. 16 Relation between engine output P2 and altitude

9. Installation

Installation of the sprinkler pump system must be carried out in accordance with the following instructions. If these instructions are not followed, malfunctions can result which can cause damage to the sprinkler pump system.

Caution

9.1 Location

Place the sprinkler pump system in a dry, frost-free and well-ventilated location. The sprinkler pump system must not be exposed to direct solar radiation. This primarily applies to the control cabinet.

Warning

Danger of suffocation!

An adequate supply of air for engine combustion must be ensured, and an adequate removal of heat and exhaust gases.

Non-compliance or impairment of the ventilation or exhaust gas system may result in danger of suffocation.

Warning

Lubricants, fuels or other highly volatile or combustible materials must not be stored near the diesel engine. These materials must be stored in a suitable, separate room.

Allow sufficient clearance around sprinkler pump and engine to enable inspection, repair and assembly work.

9.2 Foundation installation

The foundation must be made in accordance with the following instructions.

Caution

Non-compliance may result in malfunctions and damage to the pump components.

Installing the sprinkler pump system on a concrete foundation which is heavy enough to provide permanent and rigid support for the entire pump is recommended. The foundation must be capable of absorbing any vibration, normal strain or shock.

As a rule of thumb, the weight of the concrete foundation should be 1.5 times the weight of the sprinkler pump system. The concrete foundation must have an absolutely level and even surface. In the foundation, install appropriate anchorage dowels to fasten the sprinkler pump system.

Figure 17 shows how to install the foundation of the sprinkler pump system. When setting up the foundation, make sure that the foundation is 200 mm larger in length and width than the dimensions of the base frame.

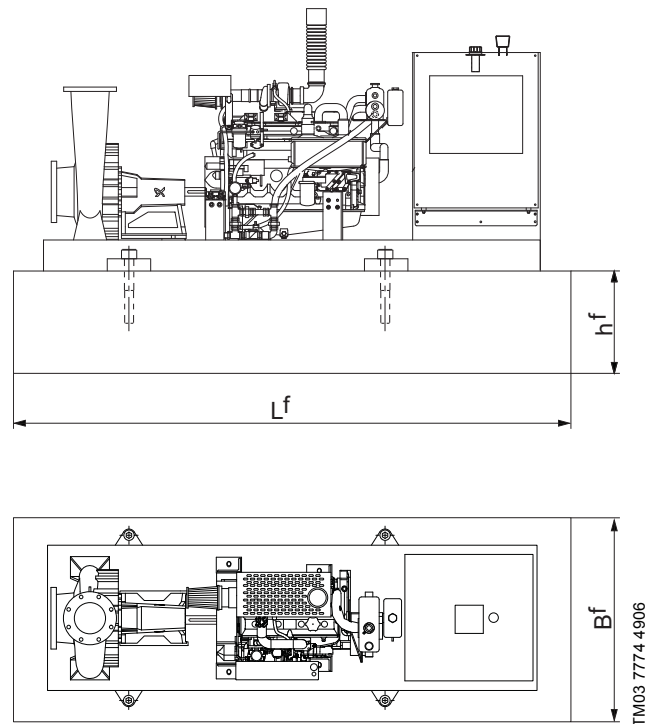

Fig. 17 Foundation dimensions

The minimum height of the foundation (h_f) can be calculated as follows, if the mass of the foundation is assumed to be 1.5 times the total mass of the sprinkler pump system:

$$h_f = \frac{m_{\text{system}} \times 1.5}{L_f \times B_f \times \rho_{\text{concrete}}}$$

The density (ρ) of the foundation is usually taken as 2,200 kg/m³. In installations where noiseless operation is particularly important, we recommend that you use a foundation with a mass of up to five times that of the sprinkler pump system. The minimum height of the foundation (h_f) can then be calculated:

$$h_f = \frac{m_{\text{system}} \times 5}{L_f \times B_f \times \rho_{\text{concrete}}}$$

9.3 Vibration dampening

To prevent vibrations from being transmitted to the building and pipework, we recommend that you fit expansion joints and vibration dampers. See fig. 18.

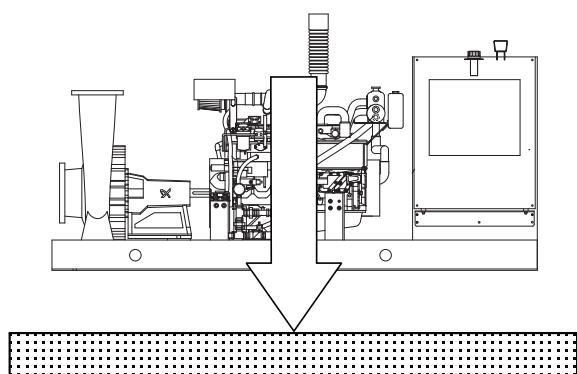

TM03 7772 4906

Fig. 18 Vibration dampening

Vibration dampers

To prevent vibrations from being transmitted to the building, we recommend that you isolate the base frame of the sprinkler pump system from buildings by means of vibration dampers.

To select the correct vibration damper, the following details are required:

- forces transferred through the damper
- the engine speed
- the desired dampening in % (recommended value: 70 %).

The selection of vibration damper differs from installation to installation. A wrong damper may, in certain cases, increase the vibration level. Vibration dampers should therefore be sized by the supplier.

If the sprinkler pump system is installed on a foundation with vibration dampers, fit expansion joints on both sides of the pump. This prevents the pump from "hanging" from the flanges.

Expansion joints

Expansion joints provide the following functions:

- Absorption of thermal expansion and contraction of pipework caused by variations in liquid temperature.
- Reduction of mechanical influences in connection with pressure surges in the pipework.
- Isolation of structure-borne noise in the pipework (only rubber bellows expansion joints).

Expansion joints must not be installed to compensate for inaccuracies in the pipework system such as misalignment or the flanges not being parallel.

Caution

Fit the expansion joints both on the suction and the discharge sides. The distance to the sprinkler pump should be at least 1-1½ x the nominal width DN. This prevents turbulence in the joints and ensures optimum suction conditions and minimum pressure drop on the discharge side of the sprinkler pump.

At high water velocities (> 5 m/s), we recommend that you fit larger expansion joints matching the pipework.

9.4 Mounting the sprinkler pump system

Warning

When lifting the entire sprinkler pump system, never use the lifting eyes of the individual components.



Use only suitable lifting equipment in proper condition. See also the weight specifications in section 20.1 Dimensions and weights.

The sprinkler pump system must only be transported when the cabinet door is closed and locked. Otherwise, there is a risk of jamming.

Warning

The permissible floor loading must not be exceeded. The weight of the sprinkler pump system is stated in the appendix and on the nameplate.



Place the sprinkler pump system on the foundation or an even floor and anchor it with adequately sized bolts. The entire base frame must be supported. See fig. 19 and fig. 20. In addition, we recommend fitting vibration dampers under the sprinkler pump system. See Section 9.3 *Vibration dampening*.

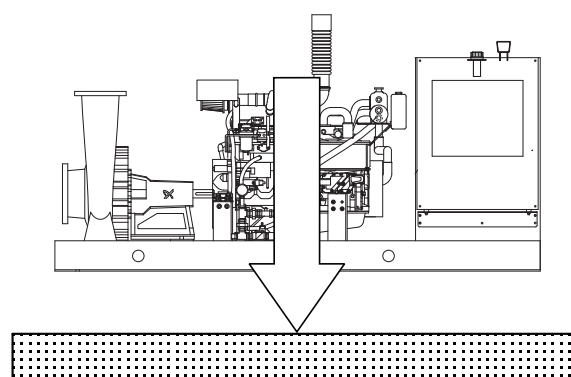

TM03 7772 4906

Fig. 19 Correct installation of the sprinkler pump system

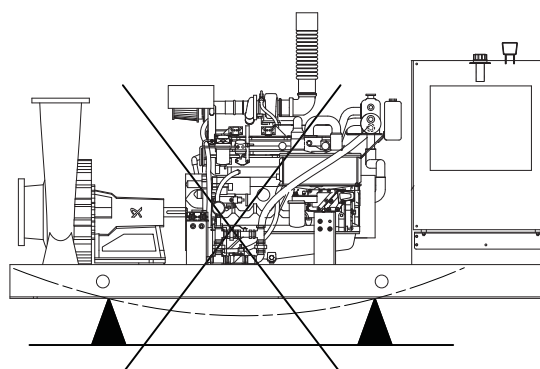

TM03 7773 4906

Fig. 20 Incorrect installation of the sprinkler pump system

9.5 Pump/engine alignment

A flexible coupling connects engine and sprinkler pump. See fig. 21.

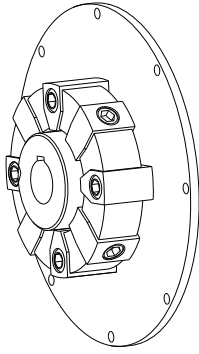

Fig. 21 Flexible coupling between pump and engine

The coupling is bolted axially on the engine fly-wheel. The pump shaft is pushed on axially and bolted radially with four bolts. See fig. 22.

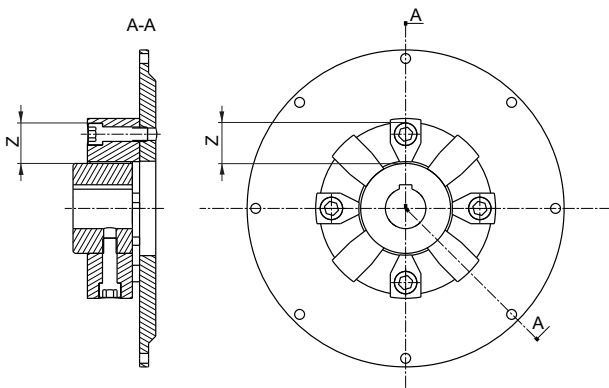

Fig. 22 Connection and alignment of pump/engine

When a complete sprinkler pump system is delivered pre-assembled from the factory, the coupling has been accurately aligned by means of shims inserted under the pump and engine, as required.

During transport and installation, the pump/engine alignment may have been affected. Therefore the alignment must always be checked when the sprinkler pump system has been installed.

The alignment must be made before connecting the pipes because otherwise moving the sprinkler pump is not possible and it is difficult to move the diesel engine.

Note

Check the final alignment when the sprinkler pump has obtained its operating temperature under normal operating conditions.

A careful alignment is important for a long service life of the coupling. This is particularly important with increased engine speed. Follow the installation instructions of the coupling manufacturer.

Caution

9.5.1 Checking the alignment

Note

You will find detailed, illustrated instructions on checking the alignment in section 6.1 Centaflex Coupling in the service manual.



Warning

Before removing the coupling guard, disconnect the battery cable.

The coupling guard may have very sharp edges. You must therefore wear protective gloves when dismantling the coupling guard!

1. Disconnect the negative pole of the starter battery.
2. Remove the coupling guard.
3. Measure the distance "Z" at the rubber element of all axial bolts. See fig. 22. The distance must be 50 mm. If the alignment is correct, proceed with step 4; otherwise align pump and engine. See section 9.5.2 *Aligning pump and engine*.
4. Refit the coupling guard.
5. Reconnect the negative pole of the starter battery.

9.5.2 Aligning pump and engine

Note

You will find detailed, illustrated instructions on aligning the pump and engine in section 6.1 Centaflex Coupling in the service manual.

Re-use the axial and radial bolts max. three times. After that, use new locking bolts.

Caution

The axial and radial bolts must never be fastened with threadlocker, as this can damage the rubber compound.

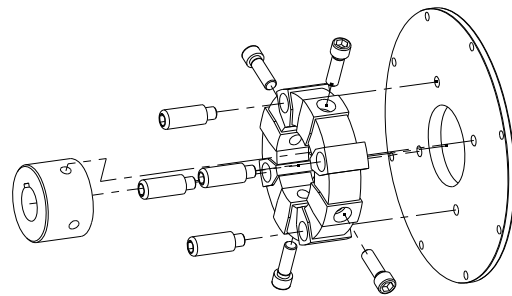

Fig. 23 Axial and radial fixation of the shaft sleeve

1. Unscrew the axial and radial bolts from the coupling and push the shaft sleeve on the shaft in the direction of the sprinkler pump.
2. Loosen the screws of the pump foot.
3. Align the pump foot using shims or foil plates.
4. Retighten the screws of the pump foot.
5. Push the shaft sleeve on the shaft in the direction of the engine and reinsert and tighten axial and radial bolts. Always insert the axial bolts first.
6. Check the alignment again, see section 9.5.1 *Checking the alignment*.

9.6 Piping

The pipework must not stress the pump housing or transfer any forces to the pump housing.

Caution *Non-compliance may damage the sprinkler pump. For permitted flange forces and torques, see section 7.2 Sprinkler pump.*

The suction hose to be installed on site must have two ports for connecting the bypass pipe (see section 9.8 Bypass pipe) and the additional pipe for the cooling loop (see section 9.9 Connecting the cooling system).

Note

The discharge line to be installed on site must have a port for venting and priming on the sprinkler pump (see section 11.1 Preparations before start-up).

Note

The pipes must be installed as straight as possible and be of an adequate size. Take the pump inlet pressure into consideration. Install the pipes so that air locks are avoided. This applies especially to the suction side of the sprinkler pump. See fig. 24.

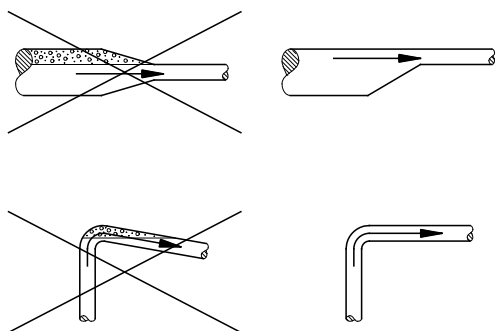

Fig. 24 Installation of pipes

Secure the pipes close to the sprinkler pump on the suction and discharge side with pipe brackets attached to the building (wall, ceiling, floor). See fig. 25.

The pipes should lie true against the pump flanges without being stressed. Otherwise, the sprinkler pump may be damaged.

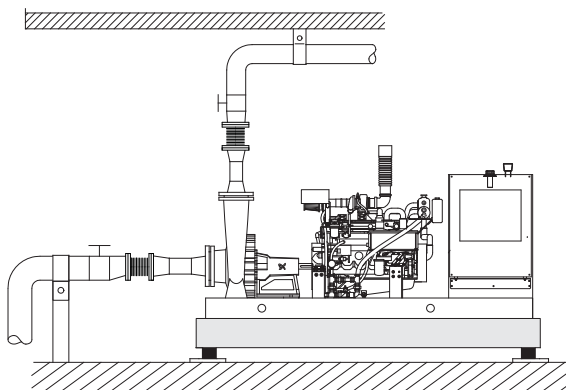

Fig. 25 Fixing points of the pipes

Isolating valves must be installed on site on suction and discharge sides of the sprinkler pump.

The suction hose must be connected on the horizontal pump port and the discharge line on the vertical pump port.

9.7 Priming tank and test pipe

If the sprinkler pump system is supplied from a storage tank, a pump priming tank must be installed on site on the suction side, in accordance with the local regulations, see EN 12845.

A test pipe branching off from the discharge pipe and leading to the storage tank must be installed on site. Both the discharge pipe and the test pipe must be fitted with isolating valves.

If the sprinkler pump system is fed directly from the public water supply, the test pipe must have an EN 12845-compliant free outlet.

9.8 Bypass pipe

A bypass pipe must be installed from the suction side of the sprinkler pump to the test pipe to guarantee that the sprinkler pump is not running against a closed valve, see 8.4 *Minimum flow rate*. There must be an appropriate port in the suction pipe for the bypass pipe.

9.9 Connecting the cooling system

Water-cooled John Deere engines are cooled by a flow of water taken from a branch pipe. The pipe is connected to the heat exchanger via a cooling circuit.

The cooling circuit consists of the pipe system, a shut-off cock (A), a diaphragm valve (B) and a pressure gauge (C). See fig. 26.

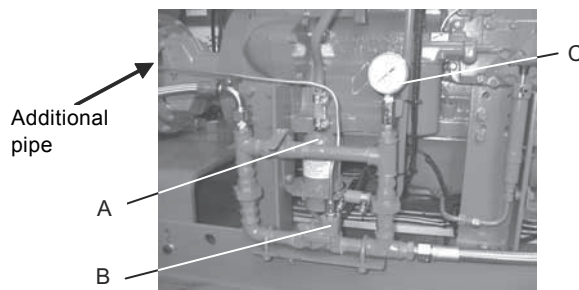

Fig. 26 Cooling circuit

Fit a hose on the discharge side of the heat exchanger (fig. 27). According to EN 12845 the other end of the hose must be a visible free outlet. The nominal hose diameter must not be smaller than the outlet on the heat exchanger (whether it is a 1" or 1¼" version).



Fig. 27 Outlet on the heat exchanger

TM04 0113 5007

TM00 2263 3393

TM03 7775 4906

TM04 9848 0211

In addition to the suction pipe of the sprinkler pump, an additional pipe must be installed on site. The suction pipe must therefore have a corresponding connection port (1/2"). The plug to be used for connecting the additional pipe is supplied with the pump system. It is attached to the fuel pipe upon delivery, see fig. 28. The additional pipe prevents water from escaping out of the storage tank through the sprinkler pump and the heat exchanger when the filling level in the storage tank is above the open discharge of the heat exchanger. The pressure on the suction side will ensure that the diaphragm valve closes (fig. 26, pos. B).

The shut-off cock (fig. 26, pos. A) is closed during normal operation. It should only be opened if the diaphragm valve is faulty and remains in closed position. A diaphragm valve blocked in closed position is indicated by a lack of pressure on the pressure gauge (fig. 26, pos. C).



Fig. 28 Plug for additional pipe

9.10 Exhaust system

Warning

Exhaust gases are to be directed safely to the open air through the exhaust system. Exhaust fumes must not escape indoors. Danger of suffocation!



Operating without an installed exhaust system is not safe!

Hot exhaust pipes must be protected to prevent accidental touch. Danger of burns!

Install exhaust pipes as straight and with as few bends as possible. Install the supplied silencer horizontally and at a sufficient distance to the engine.

Note

If you have higher noise level requirements, you have the option of ordering and installing another silencer.

The exhaust system is to be arranged so that no condensation water can enter the engine. The exhaust system must be attached to the building. The exhaust pipe to be installed must be connected to the flexible exhaust port on the engine, see fig. 29. The exhaust port is covered for transportation by a plastic plug which must be removed before fitting the exhaust pipe. The flexible connection on the engine must not be used to compensate for misaligned pipework. The minimum diameter of the exhaust pipes must not be smaller than the exhaust port on the engine see section 20.1 *Dimensions and weights*.

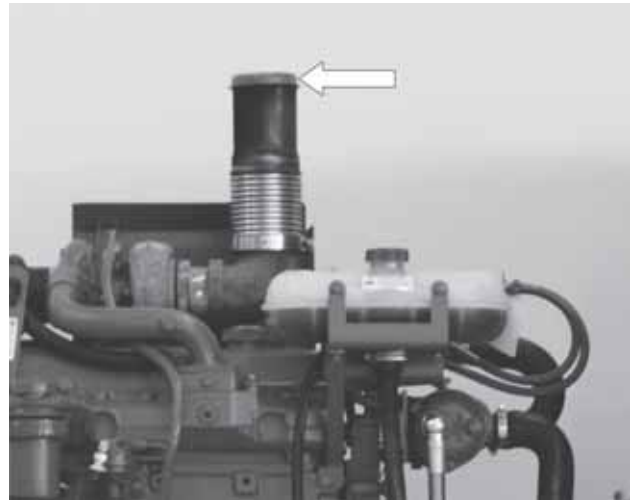

Fig. 29 Exhaust port on the engine

9.11 Separate fuel tank

Note

The provisions of EN 12845 must be observed when sizing and installing a separate fuel tank.

The fuel tank can also be arranged separately in some designs. In these cases, the fuel tank must be installed in a dry and well-ventilated location and as close as possible to the sprinkler pump system. Furthermore, the fuel tank must be fastened to the floor using the mounting holes provided. Connect the fuel pipes corresponding to fig. 30 to the flow pipe (pos. A, coming from the manual fuel supply pump) and the return pipe (pos. B, coming from the injection pump).

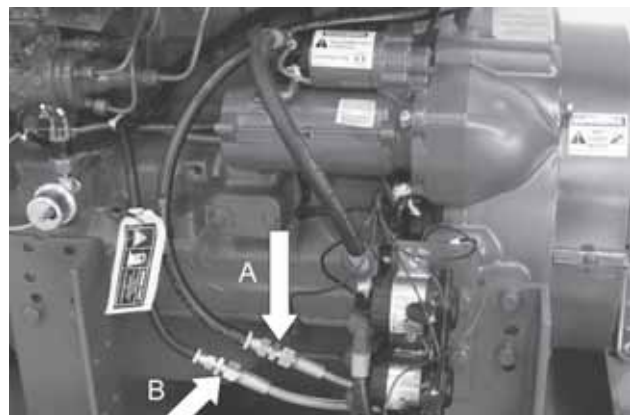

Fig. 30 Connecting the fuel pipes

10. Electrical connection



Warning

The electrical connection should only be carried out by qualified personnel in accordance with local specifications and regulations.



Warning

Before starting, check that the voltage specified on the nameplate of the control cabinet corresponds to the available mains voltage.

The electrical connection must be made in accordance with the wiring diagram enclosed in the control cabinet.

Procedure

- The connection to the mains supply must be fitted with a fuse of the correct size, in accordance with the local regulations, and connected to the main switch in the control cabinet. PE (protection earth) must be connected using the PE terminal block.
- Pressure switch 1 must be connected in the control cabinet to terminals 81 and 82 and pressure switch 2 to terminals 83 and 84.
- The battery cables must be connected to the two batteries. Each positive pole is identified in red and must be connected first. Figure 31 shows the designation of the batteries.
- If the operating and fault alarms are to be transmitted to a master controller, terminals 30 to 49 must be used for this, see also section 4.4.3 *Inputs and outputs*.

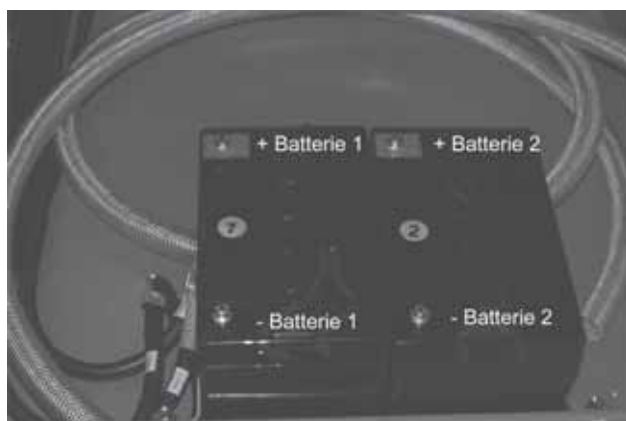

TM04 9852 0211

Fig. 31 Connecting the battery

Connecting additional sensors

- If there is a level switch for measuring the filling level in the priming tank, this must be connected to terminals 85 and 86.
- If an external appliance is to be monitored via the controller, the signal cables must be connected to terminals 87 and 88.
- If the fuel tank is supplied separately, the filling level indicator must be connected to terminal 63.

11. Commissioning



Warning

Start-up may only be carried out by authorised and qualified personnel.



Warning

The control cabinet of the controller must remain closed during start-up. Danger of electric shock!

11.1 Preparations before start-up

Caution

To prevent damage to the engine, it is essential to check the levels of oil and cooling liquid in the engine prior to start-up.

1. Check that all screw connections are fitted securely.
2. Check that all pipes are installed correctly.
3. Check that all electrical connections inside and outside the controller are correctly connected and fitted securely.
4. Check that all fuses in the control cabinet are switched on.
5. Check the alignment of the coupling, see section 9.5.1 *Checking the alignment*.
6. Check the V-belt tension, see section 14.4.10 *Check V-belt*.
7. Check that all safety devices are installed.
8. Check the oil level, see section 14.4.1 *Check oil level*. If the oil level is too low, refill with oil, see section 14.4.2 *Filling the oil*.
9. Check the coolant level, see section 14.4.3 *Check cooling system*. If the coolant level is too low, refill with cooling liquid, see section 14.4.4 *Re-fill cooling liquid*.
10. Fill the fuel tank with diesel fuel, see section 14.4.6 *Filling the fuel*.
11. Set pressure values on the pressure switches, see pressure switch operating manual. The "system pressure - 0.5 bar" can be used as a reference value for settings.
12. Fill the sprinkler pump and suction line with water. To do this unscrew the filling and venting plugs in the discharge line and open the isolating valve on the suction side. Then fill water via the filling opening in the discharge line until the water discharges from the filling opening again. Then screw the plug in again.
13. Make sure that any storage tank and pump priming tank are filled with enough water.

11.2 Starting up the sprinkler pump system



Warning
Use suitable hearing protection while the sprinkler pump system is running.



Warning
Before starting up the sprinkler pump system, fuel tanks should not be in the installation room any more!







Warning
Fuel vapours are flammable. The engine must not be started as long as there are fuel vapours in the room.



Warning
Exhaust gases are to be directed safely to the open air through the exhaust system. Exhaust fumes must not escape indoors. Danger of suffocation!
Operating without an installed exhaust system is not safe!
Hot exhaust pipes must be protected to prevent accidental touch. Danger of burns!

Procedure

Step	Figure
1. Turn the main switch to "ON" position.	
2. Turn the selector switch to "Test" position by means of the button.	
3. Open the fuel cock on the fuel tank.	

Step	Figure
4. Actuate the manual fuel supply pump.	
5. Open the isolating valve on the suction side of the sprinkler pump. Close the isolating valve on the discharge side of the sprinkler pump. Open the isolating valve of the test pipe.	
6. Start the diesel engine manually by actuating the ON button. Keep pressing the ON button until the engine starts up, however not longer than 15 seconds per start attempt.	

Note: If the engine does not start, check the error messages and instructions on the display. Perhaps the fuel system should be vented, see section 14.4.7 *Venting the fuel system*. For further causes, see section 15. *Fault finding chart*.

7. Slowly open the isolating valve on the discharge side of the sprinkler pump. To vent, loosen the vent plug in the discharge line. As soon as liquid escapes, retighten the air vent screw to 25 Nm (1/2") or 30 Nm (3/8"). When the pump reaches operating pressure, open the isolating valve sufficiently to reach the duty point.	
8. Compare the oil pressure, the temperature and the speed on the display with the nominal values, see section 7.3 <i>Diesel engine</i> .	

Step**Figure**

9. Stop the diesel engine manually by pressing the OFF button.

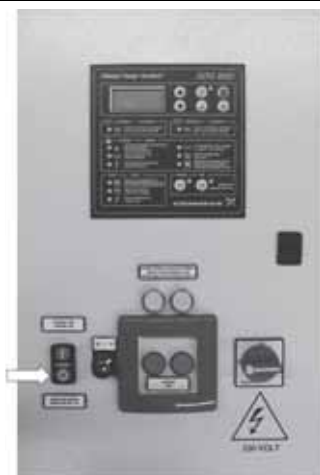

10. Turn the selector switch to "Auto" position by means of the button.



11. Close the isolating valve of the test pipe.

The sprinkler pump system is now operational and in automatic mode.

11.3 Checking the function

In connection with the start-up, a final test run must be carried out according to EN 12845. To do this, activate the automatic start-up command by lowering the pressure in the discharge pipe with a closed fuel cock. The lowering of the pressure is carried out by opening the isolating valve to the test line.

Every starting cycle consists of a 5-10-second starting phase followed by a 5-10-second pause. After six failed start attempts, a start failure alarm "DIESEL PUMP FAILURE TO START" must be activated.

When the fuel cock has been opened and the fault indication has been removed by pressing the button , the sprinkler pump should start properly.

12. Operation



Warning

During and immediately after operation, the surfaces, components and working materials of the diesel engine can be very hot.



Warning

Use suitable hearing protection while the sprinkler pump system is running.

Warning

Exhaust gases are to be directed safely to the open air through the exhaust system. Exhaust fumes must not escape indoors. Danger of suffocation!



Operating without an installed exhaust system is not safe!

Hot exhaust pipes must be protected to prevent accidental touch. Danger of burns!



Warning

Fuel vapours are flammable. The engine must not be started so long as there are fuel vapours in the room.

The most important operating parameters and alarm messages appear in the display and are indicated via LEDs in the control panel of the PLC controller, see section 5.4 *Operating and fault indications*. If the outputs of the sprinkler pump system are connected to a building management system, the operation can be monitored remotely.

To remove any faults arising see section 15. *Fault finding chart*.

Alarm messages which are not automatically reset must be reset by pressing the reset button in the control panel of the PLC controller, see fig. 32.



Fig. 32 Manual resetting of alarms

The four possible modes are described in the following sub-sections:

- Automatic operation (normal operation)
- Manual operation (for commissioning and after servicing and repair work)
- Emergency operation (if automatic operation disrupted)
- Test run.

12.1 Automatic operation

Once the sprinkler pump system has been installed and started up according to the instructions, no further operation is necessary. The sprinkler pump system works automatically and switches itself on as soon as water is taken from the sprinkler system and the pressure switch therefore detects a pressure drop.

In automatic operation, the function selector (fig. 4, pos. 7) must be in "AUTO" position. The yellow "DIESEL FIRE PUMP STARTER SWITCHED OFF" status LED in the PLC control panel does not light up.

Note

System in automatic operation

The sprinkler pump system is in automatic operation when the main switch is in "On" position and the function selector in "Auto" position.



Stopping the system

The sprinkler pump system is normally stopped by turning the function selector to "Test" position (1st step) and then pressing the OFF button (2nd step).



Emergency shut-down

Emergency shut-down is possible by turning the main switch to "OFF" position. To recommission the system, the main switch must be turned to "ON" position again.

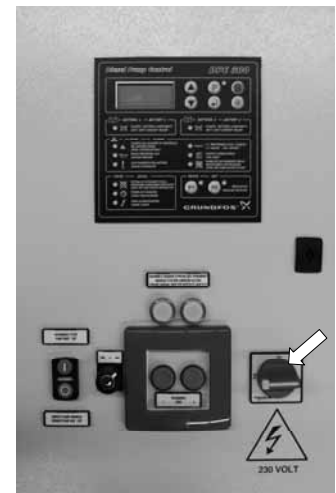

Alternatively, close the fuel cock on the tank for emergency shut-down.



Emergency shut-down is also possible by pulling the STOP-lever on the injection pump.



Note

If started up due to a false alarm, the sprinkler pump should not operate for more than 48 hours. If the pump has been running for more than 48 hours after a false alarm, always dismantle the sprinkler pump and inspect it for visible signs of wear or damage. If necessary, replace any defective components. For this, see section 7. Service work to the sprinkler pump, in the service manual.

Note





The sprinkler pump system is not shut down when disruptions occur.

12.2 Manual operation

The sprinkler pump system can also be manually started and shut down for a functional test, for commissioning or after service work.

Note *The sprinkler pump is assumed to have already been vented and commissioned.*



Start-up procedure

Step	Figure
1. Turn the main switch to "ON" position if this has not happened yet.	
2. Turn the selector switch to "Test" position.	
3. Open the fuel cock on the fuel tank, if this has not happened yet.	
4. Activate the manual fuel supply pump.	
5. Open the isolating valve of the test pipe.	

Step	Figure
6. Start the diesel engine manually by pressing the ON button. Keep pressing the ON button until the engine starts up, however not longer than 15 seconds per start attempt.	

Note: If the engine does not start, check the fault readings and instructions on the display. For further causes, see 15. *Fault finding chart.*

Stopping procedure

Step	Figure
1. Stop the diesel engine manually by pressing the OFF button.	
2. Turn the selector switch to "Auto" position.	
3. Close the isolating valve of the test pipe.	

Note *After stopping, the sprinkler pump system is in automatic mode again.*

12.3 Emergency

If the engine of the sprinkler pump system does not start up in automatic operation after six start attempts, the automatic operation is blocked and the yellow "DIESEL PUMP FAILURE TO START" LED will light up in the control panel. The text "Start Failure" will appear as a warning indication in the display. Also, the integrated indicator lights will light up in the push buttons (fig. 4, pos. 2 and 3). Then, it is possible to start the sprinkler pump system manually via the push buttons, see fig. 33. Keep pressing the push buttons until the engine starts up, however, not longer than 15 seconds. Carry out the start attempts alternately using the left and right push button. The shutdown is carried out as described in section 12.2 *Manual operation* (Stop procedure).

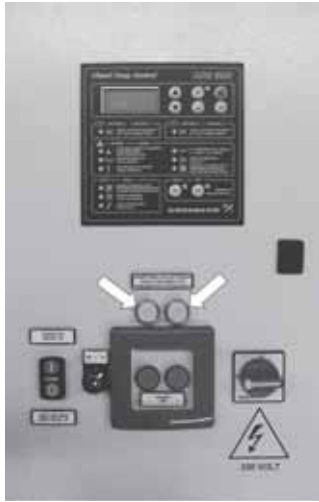

Fig. 33 Manual start via push buttons after false start

If the sprinkler pump system cannot be started via the two push buttons with integrated indicator lights or if the controller is defective and, for example, the yellow "DIESEL CONTROLLER FAULT" LED in the control panel, the last possibility is starting the engine of the sprinkler pump system via the two emergency start-up buttons arranged behind a glass panel, see fig. 34. To do this, smash the glass panel. Keep pressing the push buttons until the engine starts up, however, not longer than 15 seconds. Carry out the start attempts alternately using the left and right push button. The shutdown is also carried out here as described in section 12.2 *Manual operation* (Stop procedure).



Fig. 34 Emergency shutdown when controller fails

12.4 Test run

The function of the pressure switch and emergency start device must be tested during a test run.

Note

When describing the test run, it is assumed that the sprinkler pump system was previously in automatic operation.

Checking the pressure switch function

Step	Figure
1. Turn the selector switch to "Test" position.	
2. Open the isolating valve of the test pipe.	
3. Start the sprinkler pump system by pressing the button P1.	
4. Stop the sprinkler pump system again by pressing the OFF button.	

Step **Figure**

5. Start the sprinkler pump system by pressing the button P2.



6. Switch off the pump again, as described in section 12.2 Manual operation.

Checking the emergency start-up device

Step **Figure**

1. Close the fuel cock on the fuel tank and open the isolating valve of the test pipe. This provokes a false start.

2. The indicator lights integrated in the push buttons will light up. Open the fuel cock again and start the sprinkler pump system by pressing one of the emergency start buttons.



3. Stop the sprinkler pump system again by pressing the OFF button. Then, the integrated indicator light in the push button must go out.

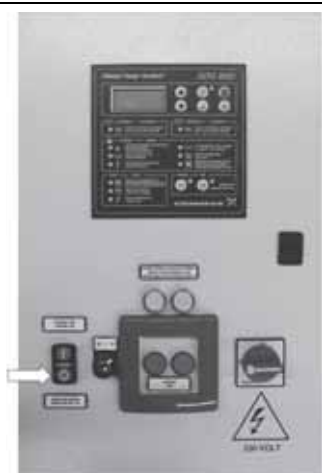

Step **Figure**

4. Start the sprinkler pump system by pressing the second emergency start button.



5. Stop the sprinkler pump system again by pressing the OFF button. Then, the integrated indicator light in the second push button must also go out.



6. Turn the selector switch to "Auto" position.



7. Close the isolating valve of the test pipe.



Note *After stopping, the sprinkler pump system is in automatic mode again.*

13. Shutdown

It is assumed that the sprinkler pump is not running at the moment of shutdown. Otherwise, the sprinkler pump system should be shut down as described in section 12.2 Manual operation.

Note

Proceed as follows to shut down the sprinkler pump system:

Step	Figure
1. Close the isolating valve on the discharge side.	
2. Close the isolating valve on the suction side.	
3. Turn off the fuel cock on the fuel tank.	
4. Turn the selector switch to "0" position.	
5. Turn the main switch to "Off" position.	
6. Firstly, disconnect the positive pole and then the negative pole of the batteries.	

The sprinkler pump must be drained when shut down for long periods. For this purpose, drain plug E must be unscrewed, see fig. 35. Firstly screw in the plug when recommissioning and tighten to 25 Nm (1/2") or 30 Nm (3/8").

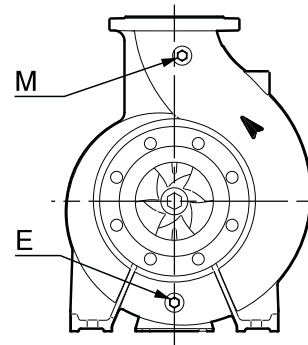

Fig. 35 Position of drain plug E

The fuel must also be drained from the fuel tank. For this purpose, the drain plug on the fuel tank must be removed (see fig. 36.) Collect the fuel in a suitable vessel.



Fig. 36 Drain plug on the fuel tank

The sprinkler pump and the engine must be protected against corrosion as described in section 3.3 Storage. In addition, give a couple of squirts of silicone oil on the pump shaft when the coupling is dismantled.

To re-start the sprinkler pump system, refill the engine oil and cooling liquid, see section 14.4.2 Filling the oil and 14.4.4 Re-fill cooling liquid. Then continue as described in section 11. Commissioning.

TM03 3935 1206

TM04 9875 0211

14. Maintenance

Note

The operator is responsible for ensuring that all maintenance, inspection and installation work is performed by qualified personnel. A regular maintenance plan will help avoid expensive repairs and contribute to trouble-free, reliable operation.

Warning

Before starting work on the sprinkler pump system, make sure that the sprinkler pump system has been switched off and cannot be accidentally switched on. To do this, turn the main switch to "OFF" position and lock it using a padlock. The negative pole on the battery should also be removed.

Maintenance work must only be performed by authorised qualified personnel.



Warning

Do not place any tools on the batteries. Risk of short circuit!



14.1 Maintenance intervals

Sprinkler pump system

Action type	Weekly	Every 6 months	Annually	Every 2 years	Section
Check that all screws are fitted securely.	x				-
Check safety devices	x				-
Check fuel level	x				14.4.5
Check fuel system	x				14.4.5
Check exhaust system	x				14.4.8
Check electrical connections			x		-
Check pump/engine alignment			x		9.5
Carry out test run (30 minutes)	x				12.4

Diesel engine

Action type	Weekly	Every 6 months	Annually	Every 2 years	Section
Check cooling system	x				14.4.3
Change cooling liquid			x		8.2.3 *)
Check oil level	x				14.4.1
Oil change with filter			x		8.2.2 *)
Change fuel filter			x		8.2.4 *)
Check V-belt		x			14.4.10
Replacement of V-belts			x		8.2.5 *)
Check air filter	x				14.4.9
Replace air filter			x		14.4.9
Replace batteries			x		14.7

*) section in the service manual for JU4H and JU6H

Controller

Action type	Weekly	Every 6 months	Annually	Every 2 years	Section
Indicator light test	x				14.6
Check cables and connections			x		14.6

14.2 Sprinkler pump system

The check of the complete sprinkler pump system comprises the following points:

- Check that all screws fit securely and are not corroded. Tighten up loose screws.
- Check all safety devices, such as coupling guard, V-belt cover.
- Read the fuel level on the level gauge. If the fuel tank is not completely full, refill with fuel, see section 14.4.6 *Filling the fuel*.
- Check the fuel system, see section 14.4.5 *Check fuel system*.
- Check that all electrical connections are fitted securely and are undamaged. Replace defective cables and re-tighten loose connections.
- Check the alignment of the pump and engine, see section 9.5 *Pump/engine alignment*.
- Carry out a test run, see also section 12.4 *Test run*.

14.3 Sprinkler pump

Maintenance-free, permanently lubricated bearings are installed in the sprinkler pump.

Mechanical shaft seals are also maintenance-free and almost leak-free. In case of considerable and increasing seepage, check the mechanical shaft seal immediately. If the seal faces are damaged, replace the entire shaft seal. See section 7. *Service work to the sprinkler pump*, in the service manual.

14.4 Diesel engine



Warning

During and immediately after operation, the surfaces, components and working materials of the diesel engine can be very hot.

14.4.1 Check oil level

To read the oil level, pull out the oil dipstick (fig. 37).

LC2A und LC3A

JU4H and JU6H

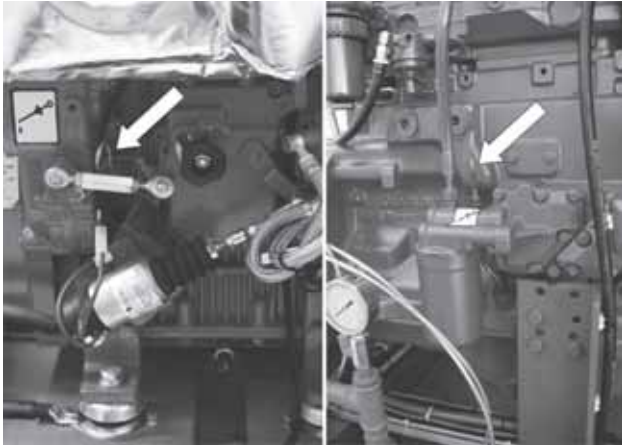

TM04 9876 0211

Fig. 37 Position of the oil dipstick

Oil level measurements are to be taken when the engine is cold. The oil level must be between the minimum and maximum mark on the oil dipstick. See fig. 38.

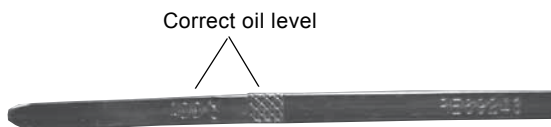

TM04 0117 5007

Fig. 38 Reading the oil level

14.4.2 Filling the oil

Do not top up oil higher than the maximum mark. Over-filling can cause damage to the engine.

Caution

Only use prescribed oil for refilling, see section 7.3 Diesel engine.

Procedure

Unscrew the oil filler cap and fill oil up to the corresponding mark on the oil dipstick. How to read the oil level is described in section 14.4.1 Check oil level.



TM04 9882 0211

Fig. 39 Oil filler cap

14.4.3 Check cooling system

Note

This section only applies to water-cooled John Deere engines.



Warning

Do not remove cap of equalisation tank when the engine is warm. The tank is under pressure! Danger of burns from escaping liquid!

The check of the cooling system comprises the following points:

1. Examine all the pipes of the cooling system for leaks. Replace defective pipes.
2. Check the level of cooling liquid in the equalisation tank. When the engine is cold, the filling level must be between the mark "MIN COLD" and "MAX COLD", see fig. 40. If the filling level of the cooling liquid is too low, re-fill with cooling liquid, see section 14.4.4 Re-fill cooling liquid.
3. Check if the pressure gauge of the cooling circuit displays a pressure value when the engine is running, see fig. 26, pos. C.

14.4.4 Re-fill cooling liquid

Note

This section only applies to water-cooled John Deere engines.



Warning

Do not remove cap of equalisation tank when the engine is warm. The tank is under pressure! Danger of burns from escaping liquid!



Warning

The pressure in the equalisation tank must not exceed 1 bar.

Caution

Only use prescribed cooling liquid. See section 7.3 Diesel engine.

Note

Over time, the coolant in the cooling liquid loses its effectiveness. The cooling liquid should therefore be changed every 2 years.

If there is too little cooling liquid in the equalisation vessel, proceed as follows:

1. Unscrew the cap (fig. 40) of the equalisation vessel.
2. Top up the cooling liquid up to the mark "MAX COLD", when the engine is cold.
3. Replace the cap of the equalisation vessel.



TM04 9883 0211

Fig. 40 Equalisation vessel

14.4.5 Check fuel system

Note

Collect water-containing and excessive fuel in a suitable vessel and dispose of it properly in accordance with local regulations.

The check of the fuel system comprises the following points:

1. Examine all the pipes of the fuel system for leaks. Replace defective fuel pipes. To fasten the fuel pipes, use Norma type torque brackets.
2. Read fuel level on the level gauge (fig. 42, pos. 2). To prevent damage by condensation and to maintain the system ready for operation, the fuel tank must always be full.
3. Drain condensate from the fuel tank. To do this, remove the drain plug (fig. 36) on the fuel tank and collect the water-containing fuel in a suitable container. As soon as only pure fuel without water discharges, retighten the drain plug.
4. Drain condensate from the fuel filter. To do so, loosen the knurled screw at the bottom of the fuel filter (see fig. 41) and collect the water in a suitable vessel. As soon as only pure fuel without water discharges, retighten the knurled screw.



Fig. 41 Knurled screw on the fuel filter

14.4.6 Filling the fuel

Warning

Fuel vapours are flammable. Therefore, never top up fuel when the engine is running or even when the engine is warm.



Do not inhale fuel vapours when filling the fuel tank.

Ensure good ventilation of the room during the refuelling so that the fuel vapours are dissipated quickly.

The engine must not be started as long as there are fuel vapours in the room.

Caution

Only use prescribed diesel fuel. See section 7.3 Diesel engine.

The fuel tank can be filled either from the top using a canister, or on the side using the manual filling pump (fig. 42, pos. 3). For filling quantities, see section 20.2 Engine data.

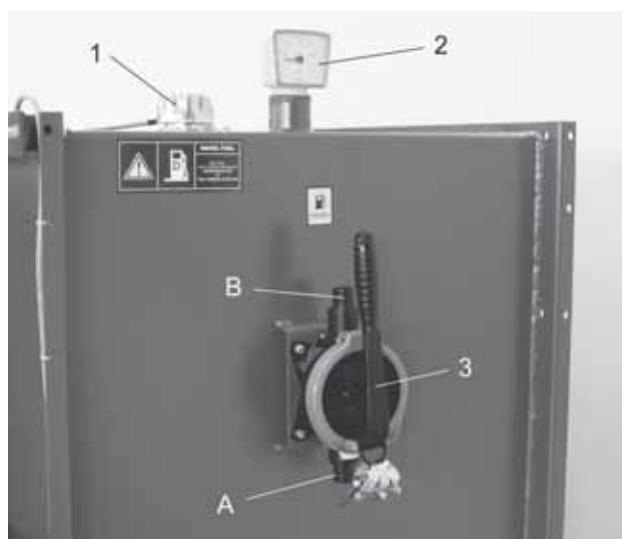

Fig. 42 Fuel tank

Filling using canister

1. Unscrew the tank cap (fig. 42, pos. 1).
2. Fill fuel using the canister up to the maximum filling level. The filling level can be read on the level gauge (fig. 42, pos. 2).
3. When the tank is full, screw the tank cap back on.

Filling using hand pump

1. Connect the hose from the diesel tank to the lower connection port (fig. 42, pos. A) of the hand pump.
2. Connect a second hose to the upper connection port (fig. 42, pos. B) of the hand pump.
3. Unscrew the tank cap (fig. 42, pos. 1).
4. Put the second hose from the upper connection port of the hand pump into the tank opening.
5. Operate the hand pump to fill the tank with fuel up to the maximum filling level. The filling level can be read on the level gauge during the filling process (fig. 42, pos. 2).
6. When the tank is full, take the hose out of the fuel tank and screw the tank cap back on.
7. Disconnect both hoses from the hand pump.

14.4.7 Venting the fuel system



Warning

Fuel escaping under pressure can penetrate the skin and cause serious injuries. The pressure must therefore always be released before the fuel pipes are disconnected. Only re-pressurize once all the pipes have been tightened securely.

Note

Collect excessive fuel in a suitable vessel and dispose of it properly in accordance with local regulations.

Note

The fuel cock on the fuel tank must be open.

The fuel system must be vented before commissioning and after replacing the fuel filter or fuel pipes. To do this, it is normally sufficient to activate the fuel supply pump, see section 11.2 *Starting up the sprinkler pump system*, step 4.

If this is not sufficient, proceed as follows:

1. Loosen the ventilation port (fig. 43, pos. A) on the filter holder and turn two turns by hand or a screw-driver.
2. Operate the lever of the fuel supply pump (fig. 43, pos. B) until the diesel fuel escaping through the ventilation port does not contain air bubbles. Collect the fuel in a suitable container and dispose of it properly.
3. Carefully tighten the ventilation port. Keep operating the lever of the fuel supply pump until no resistance is felt.
4. Start the engine manually, see section 12.2 *Manual operation*, and then check the fuel system for leaks. After checking, switch off the engine again.



Fig. 43 Venting the fuel system on the fuel filter

TM04 9886 0211

If the engine does not start, the fuel system may also need to be vented at the diesel injection pump. The procedure is as follows:

1. Loosen the connector (fig. 44) at the fuel backflow pipe.
2. Operate the lever of the fuel supply pump until the diesel fuel escaping through the connector does not contain air bubbles. Collect the fuel in a suitable container and dispose of it properly.
3. Re-tighten the connector to 16 Nm.
4. Start the engine manually, see section 12.2 *Manual operation*, and then check the fuel system for leaks. After checking, switch off the engine again.



Fig. 44 Vent the fuel system on the diesel injection pump

TM04 9887 0211

14.4.8 Check exhaust system



Warning

Mortal danger!

A damaged exhaust gas system may result in suffocation.

Check the entire exhaust pipe system for leaks whilst the engine is running. Tighten loose pipe connections and replace defective pipes immediately.

14.4.9 Check air filter

Examine the air filter for dirt particles. Replace dirty air filters.

To remove the air filter, loosen clamp (A) and pull off filter element (B), see fig. 45. To assemble it, do the same in reverse order.



Fig. 45 Air filter

TM04 9888 0211





14.4.10 Check V-belt

Note This section only applies to John Deere engines.

Note Replacing the V-belt is described in section 8.2.5 Replacing the V-belt, in the service manual.

Check the V-belt and belt pulleys for wear. In addition, check the V-belt tension.

Procedure

Step	Figure
1. Remove the screws from the protective cover and take it off.	
2. Check the tension of the V-belt. To do this, press the V-belt with your thumb at the place indicated by the arrow. The elasticity at the arrow must be between 1 and 1.5 cm. In addition, check the V-belt and the belt pulley for signs of wear.	
3. If V-belt tension is wrong, loosen the two adjusting nuts on the generator. Otherwise, continue with step 5.	
4. Push the generator outwards using a suitable tool until the correct tension is reached. Tighten the two adjusting nuts one by one.	
5. Reinstall the protective cover.	

14.5 Coupling

The Centaflex coupling is maintenance-free. However, check the alignment between the sprinkler pump and the engine once a year, see section 9.5 Pump/engine alignment.

14.6 Controller



Warning

Before opening the control cabinet, switch off the voltage supply via the main switch. Otherwise, there is a risk of death due to electric shock!

The following maintenance work must be carried out regularly:

- Check all cables and connections
- Indicator light test.

Check once a year that all screw connections of the terminals and all earth connections are tight. Any loose connections must be tightened. Check the cables for visible damage and replace, if necessary.

To test the function of the indicator lights, press the button "Indicator light test", see fig. 46. If an indicator light fails, please contact Grundfos.



Fig. 46 Indicator light test

14.7 Batteries

Both starter batteries are maintenance-free.

If the starter batteries have to be replaced, firstly remove the negative pole and then the positive pole. The positive pole is marked red. Connect the cables in reverse order, i.e. firstly the positive pole and then the negative pole. Figure 31 shows how to connect the battery.

TM04 9893 0211

15. Fault finding chart



Warning

Before any servicing of the sprinkler pump system, make sure that the sprinkler pump system cannot accidentally start.

Fault	Cause	Remedy
1. Sprinkler pump delivers no or too little water.	a) Air in suction pipe.	Fill priming tank with water and vent sprinkler pump. Make sure the suction pipe has been installed according to section 9.6 <i>Piping</i> .
	b) Sprinkler pump draws in air due to defective gaskets.	Check the pipeline gaskets and pump housing gaskets, and replace if necessary.
	c) Counter-pressure too high.	Check the sprinkler system for impurities and blockages.
	d) Inlet pressure too low.	Make sure that the storage tank is filled with enough water and that the conditions in section 8.2 <i>Minimum inlet pressure</i> are complied with.
	e) Suction pipe or impeller blocked.	Clean suction pipe and sprinkler pump.
2. Sprinkler pump makes strange noises and/or runs unevenly.	a) Inlet pressure too low (cavitation).	Make sure that the storage tank is filled with enough water and that the conditions in section 8.2 <i>Minimum inlet pressure</i> are complied with.
	b) Air in suction pipe.	Fill priming tank with water. Vent sprinkler pump. Make sure the suction pipe has been installed according to section 9.6 <i>Piping</i> .
	c) Impeller out of balance.	Clean the impeller and remove foreign particles.
	d) Inner parts worn.	Replace defective parts. See section 7. <i>Service work to the sprinkler pump</i> , in the service manual.
	e) Pump stressed by the pipework.	Mount the pump so that it is not stressed. Support the pipes. See section 9.6 <i>Piping</i> .
	f) Defective bearings.	Replace bearings. See section 7. <i>Service work to the sprinkler pump</i> , in the service manual.
	g) Defective coupling.	Replace coupling. See service manual, section 6.1 <i>Centaflex Coupling</i> .
	h) Foreign bodies in the sprinkler pump.	Clean the sprinkler pump and remove foreign bodies.
3. Leakage in pump housing.	a) Pump stressed by the pipework.	Mount the pump so that it is not stressed. Support the pipes. See section 9.6 <i>Piping</i> .
	b) Pump housing gaskets or flange gaskets defective.	Replace defective gaskets. See section 7. <i>Service work to the sprinkler pump</i> , in the service manual.
4. Leakage in the shaft seal.	a) Mechanical shaft seal dirty or seized up.	Check and clean the mechanical shaft seal.
	b) Mechanical shaft seal defective.	Replace the mechanical shaft seal. See section 7. <i>Service work to the sprinkler pump</i> , in the service manual.
	c) Shaft surface or shaft sleeve defective.	Replace the shaft or the shaft sleeve. See section 7. <i>Service work to the sprinkler pump</i> , in the service manual.
5. Too high sprinkler pump temperature.	a) Air in sprinkler pump.	Fill priming tank with water and vent sprinkler pump.
	b) Inlet pressure too low.	Make sure that the storage tank is filled with enough water and that the conditions in section 8.2 <i>Minimum inlet pressure</i> are complied with.
	c) Bearings lubricated with too little, too much or unsuitable lubricant.	Replenish, reduce or replace the lubricant.
	d) Sprinkler pump bearing seat stressed by wrongly installed pipework.	Mount the pump so that it is not stressed. Support the pipes. Check the alignment of the pump, and correct, if necessary. See section 9.5 <i>Pump/engine alignment</i> .
	e) Axial pressure too high.	Check the relief holes of the impeller and the lock rings on the suction side.

Fault	Cause	Remedy
6. Engine does not start.	a) Fuel cock closed.	Open fuel cock on the fuel tank.
	b) No diesel in the tank.	Fill tank with diesel. Vent fuel system. See section 14.4.6 <i>Filling the fuel</i> and 14.4.7 <i>Venting the fuel system</i> .
	c) Fuel filter blocked.	Change fuel filter. See service manual, section 8.1.4 or 8.2.4 <i>Replacing the fuel filter</i> .
	d) Air in fuel system.	Vent fuel system. See section 14.4.7 <i>Venting the fuel system</i> .
	e) Water in the fuel or incorrect fuel.	Drain fuel from the fuel tank. Fill with new fuel. Vent fuel system. See sections 14.4.6 <i>Filling the fuel</i> , 14.4.5 <i>Check fuel system</i> and 14.4.7 <i>Venting the fuel system</i> .
	f) Starter relay defective.	Replace starter relay.
	g) Insufficient power supply.	Check power supply to the control cabinet, batteries and cables on the sprinkler pump system.
	h) Sprinkler pump blocked.	Remove sprinkler pump and repair if necessary. See section 7. <i>Service work to the sprinkler pump, in the service manual</i> .
	i) Exhaust pipes blocked.	Remove foreign bodies from exhaust pipes.
7. Oil pressure is too high or too low when engine is running.	a) Oil filter blocked.	Replace oil filter. See service manual, section 8.1.2 or 8.2.2 <i>Oil change with filter</i> .
	b) Water or fuel in the oil.	Change oil. See service manual, section 8.1.2 or 8.2.2 <i>Oil change with filter</i> .
	c) Oil level too low/too high.	Refill with oil or drain off oil. See section 14.4.2 <i>Filling the oil</i> . See service manual, section 8.1.2 or 8.2.2 <i>Oil change with filter</i> .
	d) Oil pump worn.	Replace oil pump. Please contact Grundfos Service regarding this.
8. Engine temperature too high.	a) Insufficient cooling liquid.	Refill cooling liquid. See section 14.4.4 <i>Re-fill cooling liquid</i> .
	a) Diaphragm valve blocked or defective.	Clean or replace diaphragm valve. As an emergency measure, open shut-off fittings to the bypass pipe.
	a) Heat exchanger defective.	Replace heat exchanger. Please contact Grundfos regarding this.
9. Engine does not reach rated speed.	a) Incorrect speed setting.	Please contact Grundfos.
	a) Fuel filter partially blocked.	Change fuel filter. See service manual, section 8.1.4 or 8.2.4 <i>Replacing the fuel filter</i> .
	a) Air in fuel system.	Vent fuel system. See section 14.4.7 <i>Venting the fuel system</i> .
	a) Traces of water in the fuel.	Drain condensate from the fuel filter. See section 14.4.5 <i>Check fuel system</i> .
	a) Turbocharger or intercooler defective (not all models).	Replace turbocharger or intercooler. Please contact Grundfos Service regarding this.
10. Battery voltage too low.	a) Cell short-circuit in starter battery.	Replace starter batteries. See section 14.7 <i>Batteries</i> .
	a) Wiring of the battery charging circuit damaged or insufficient terminal contact.	Check wiring and replace if necessary. Check terminal connections and tighten, if necessary.
	a) Insufficient power supply to the control cabinet.	Check power supply.
	a) V-belt tension too low.	Check V-belt tension and correct if necessary. See section 14.4.10 <i>Check V-belt</i>
	a) Battery charging unit defective.	Replace battery charging unit. Please contact Grundfos Service regarding this.
11. Strong exhaust gas colouring.	a) Dirty air filter.	Replace air filter. See section 14.4.9 <i>Check air filter</i> .

16. Service, accessories, spare parts

Note

Please note explicitly that spare parts and accessories not supplied by Grundfos are not inspected or approved by Grundfos either.

The installation and/or use of such products may negatively alter and thus impair the specified properties of the sprinkler pump system.

The use of non-original spare parts and accessories renders any liability on behalf of Grundfos for resulting damage null and void.

Any malfunctions which cannot be repaired should only be corrected by Grundfos or authorised service partners.

If there is a malfunction, please provide a full description of the malfunction so that the service technician can prepare and provide the appropriate spare parts.

The technical data for the system can be obtained from the nameplates, see section 6.1 *Nameplates*.

17. Warranty

The warranty is according to our general terms of delivery.

Liability for any damage which is a result of errors during installation, electrical connection or incorrect use is excluded.

Liability for consequential damage is excluded. The start of the warranty period is to be verified.

18. Related documentation

These operating instructions are to be used in conjunction with the following documentation:

- Wiring diagram for controller
- Pressure transmitter operating instructions
- Service manual for the sprinkler pump systems
- Data booklet (publication number 97641687).

19. Disposal

This product or parts of it must be disposed of in an environmentally sound way:

1. Use the public or private waste collection service.
2. If this is not possible, contact the nearest Grundfos company or service workshop.

20. Appendix

20.1 Dimensions and weights

Designation	Engine type	Sprinkler pump system		Sprinkler pump			Engine	
		Dimensions *) L x W x H [mm]	Weight *) [kg]	Suction port	Discharge port	Weight [kg]	Exhaust gas port [mm]	Weight [kg]
Fire NKF 32-200/176 Fire NKF 32-200/190 Fire NKF 32-200/206 Fire NKF 32-200/219	LC2A-NL30	2050 x 700 x 1500	933	DN 50	DN 32	47		104
Fire NKF 40-250/210 Fire NKF 40-250/230 Fire NKF 40-250/238 Fire NKF 40-250/250 Fire NKF 40-250/260	LC2A-NL30 LC2A-NL30 LC2A-NL30 LC3A-NL30 JU4H-NL14	2050 x 700 x 1500 2050 x 700 x 1500 2050 x 700 x 1500 2050 x 700 x 1500 2600 x 1156 x 1600	933 933 933 987 1222		DN 65 DN 40	64		104 104 104 104 413
Fire NKF 50-200/170 Fire NKF 50-200/194 Fire NKF 50-200/207 Fire NKF 50-200/219	LC2A-NL30 LC2A-NL30 LC2A-NL30 LC3A-NL30		933 933 933 987	DN 65	DN 50	56		104 104 104 104
Fire NKF 50-250/205 Fire NKF 50-250/220 Fire NKF 50-250/249 Fire NKF 50-250/263	LC2A-NL30 LC3A-NL30 JU4H-NL14 JU4H-NL14	2050 x 700 x 1500 2050 x 700 x 1500 2600 x 1156 x 1600 2600 x 1156 x 1600	999 999 1267 1267	DN 65	DN 50	67	76 76	413 413
Fire NKF 65-160/152 Fire NKF 65-160/161 Fire NKF 65-160/173	LC3A-NL30	2050 x 700 x 1500	987	DN 80	DN 65	46		
Fire NKF 65-200/170 Fire NKF 65-200/185 Fire NKF 65-200/195 Fire NKF 65-200/214 Fire NKF 65-200/219	LC2A-NL30 LC2A-NL30 LC3A-NL30 JU4H-NL14 JU4H-NL14	2050 x 700 x 1500 2050 x 700 x 1500 2050 x 700 x 1500 2600 x 1156 x 1600 2600 x 1156 x 1600	933 933 987 1255 1255	DN 80	DN 65	55	76 76	413 413
Fire NKF 80-200/188 Fire NKF 80-200/202 Fire NKF 80-200/213 Fire NKF 80-200/222	JU4H-NL14 JU4H-NL14 JU4H-NL14 JU4H-NL24		1333	DN 100	DN 80	73	76	413
Fire NKF 80-250/216 Fire NKF 80-250/233 Fire NKF 80-250/255 Fire NKF 80-250/270	JU4H-NL14 JU4H-NL24 JU4H-NL34 JU4H-NL34		1360	DN 100	DN 80	93	76 76 102 102	413 413 424 424
Fire NKF 100-200/209 Fire NKF 100-200/215 Fire NKF 100-200/219	JU4H-NL14 JU4H-NL24 JU4H-NL34		1350	DN 125	DN 100	83	76 76 102	413 413 424
Fire NKF 125-250/237 Fire NKF 125-250/245 Fire NKF 125-250/255 Fire NKF 125-250/269	JU4H-NL54 JU6H-NL34 JU6H-NL74 JU6H-NL84	2600 x 1158 x 1600 2800 x 1158 x 1630 2800 x 1158 x 1630 2800 x 1158 x 1630	1350 1486 1486 1486	DN 150	DN 125	133	102 127 127 127	424 750 766 766

*) Details apply to compact systems with fuel tank installed on the base frame.

20.2 Engine data

Designation	Engine type	Engine output [kW]	Speed [rpm]	Air requirements [m ³ /min]	Exhaust volume [m ³ /min]	Quantity of oil [l]	Oil pressure [bar]	Quantity of cooling liquid [l]	Fuel tank volume [l]	
Fire NKF 32-200/176	LC2A-NL30	19	2960	1.1	2.8	1.8	2.8 - 3.4	-		
Fire NKF 32-200/190								-		
Fire NKF 32-200/206								-		
Fire NKF 32-200/219								-		
Fire NKF 40-250/210	LC2A-NL30	19	2960	1.1	2.8	1.8	2.8 - 3.4	-		
Fire NKF 40-250/230	LC2A-NL30	19	2960	1.1	2.8	1.8	2.8 - 3.4	-		
Fire NKF 40-250/238	LC2A-NL30	19	2960	1.1	2.8	1.8	2.8 - 3.4	-		
Fire NKF 40-250/250	LC3A-NL30	26	2960					-		
Fire NKF 40-250/260	JU4H-NL14	48	2600	5.3	15	8.5	2.5 - 3.4	14.2	300	
Fire NKF 50-200/170	LC2A-NL30	19	2960	1.1	2.8	1.8	2.8 - 3.4			
Fire NKF 50-200/194	LC2A-NL30	19		1.1	2.8	1.8	2.8 - 3.4	-		
Fire NKF 50-200/207	LC2A-NL30	19		1.1	2.8	1.8	2.8 - 3.4	-		
Fire NKF 50-200/219	LC3A-NL30	26								
Fire NKF 50-250/205	LC2A-NL30	19	2960	1.1	2.8	1.8	2.8 - 3.4	-		
Fire NKF 50-250/220	LC3A-NL30	26						-		
Fire NKF 50-250/249	JU4H-NL14	48		5.3	15	8.5	2.5 - 3.4	14.2	300	
Fire NKF 50-250/263	JU4H-NL14	48		5.3	15	8.5	2.5 - 3.4	14.2	300	
Fire NKF 65-160/152	LC3A-NL30	26	2960					-		
Fire NKF 65-160/161									-	
Fire NKF 65-160/173										-
Fire NKF 65-200/170	LC2A-NL30	19	2960	1.1	2.8	1.8	2.8 - 3.4	-		
Fire NKF 65-200/185	LC2A-NL30	19	2960	1.1	2.8	1.8	2.8 - 3.4	-		
Fire NKF 65-200/195	LC3A-NL30	26	2960					-		
Fire NKF 65-200/214	JU4H-NL14	48	2600	5.3	15	8.5	2.5 - 3.4	14.2	300	
Fire NKF 65-200/219	JU4H-NL14	48	2600	5.3	15	8.5	2.5 - 3.4	14.2	300	
Fire NKF 80-200/188	JU4H-NL14	48	2600	5.3	15					
Fire NKF 80-200/202	JU4H-NL14	48	2600	5.3	15	8.5	2.5 - 3.4	14.2	300	
Fire NKF 80-200/213	JU4H-NL14	48	2600	5.3	15					
Fire NKF 80-200/222	JU4H-NL24	64	2800	5.7	16					
Fire NKF 80-250/216	JU4H-NL14	48	2600	5.3	15					
Fire NKF 80-250/233	JU4H-NL24	64	2800	5.7	16	8.5	2.5 - 3.4	14.2	300	
Fire NKF 80-250/255	JU4H-NL34	96	2960	10.0	26					
Fire NKF 80-250/270	JU4H-NL34	96	2960	10.0	26					
Fire NKF 100-200/209	JU4H-NL14	48	2600	5.3	15					
Fire NKF 100-200/215	JU4H-NL24	64	2800	5.7	16	8.5	2.5 - 3.4	14.2	300	
Fire NKF 100-200/219	JU4H-NL34	96	2960	10.0	26					
Fire NKF 125-250/237	JU4H-NL54	119	2960	11.7	33.8					
Fire NKF 125-250/245	JU6H-NL34	141	2960	17.1	45.7					
Fire NKF 125-250/255	JU6H-NL74	184	2960	20.3	55.3	8.5	2.5 - 3.4	14.2	300	
Fire NKF 125-250/269	JU6H-NL84	225	3000	20.3	55.3					

*) Details apply to compact systems with fuel tank installed on the base frame.

Argentina

Bombas GRUNDFOS de Argentina S.A.
Ruta Panamericana km. 37.500 Lote 34A
1619 - Garin
Pcia. de Buenos Aires
Phone: +54-3327 414 444
Telefax: +54-3327 411 111

Australia

GRUNDFOS Pumps Pty. Ltd.
P.O. Box 2040
Regency Park
South Australia 5942
Phone: +61-8-8461-4611
Telefax: +61-8-8340 0155

Austria

GRUNDFOS Pumpen Vertrieb Ges.m.b.H.
Grundfosstraße 2
A-5082 Grödig/Salzburg
Tel.: +43-6246-883-0
Telefax: +43-6246-883-30

Belgium

N.V. GRUNDFOS Bellux S.A.
Boomssesteenweg 81-83
B-2630 Aartselaar
Tél.: +32-3-870 7300
Télécopie: +32-3-870 7301

Belorussia

Представительство ГРУНДФОС в
Минске
220123, Минск,
ул. В. Хоружей, 22, оф. 1105
Тел.: +(37517) 233 97 65,
Факс: +(37517) 233 97 69
E-mail: grundfos_minsk@mail.ru

Bosnia/Herzegovina

GRUNDFOS Sarajevo
Trg Heroja 16,
BiH-71000 Sarajevo
Phone: +387 33 713 290
Telefax: +387 33 659 079
e-mail: grundfos@bih.net.ba

Brazil

BOMBAS GRUNDFOS DO BRASIL
Av. Humberto de Alencar Castelo Branco,
630
CEP 09850 - 300
São Bernardo do Campo - SP
Phone: +55-11 4393 5533
Telefax: +55-11 4343 5015

Bulgaria

Grundfos Bulgaria EOOD
Slatina District
Iztochna Tangenta street no. 100
BG - 1592 Sofia
Tel. +359 2 49 22 200
Fax. +359 2 49 22 201
email: bulgaria@grundfos.bg

Canada

GRUNDFOS Canada Inc.
2941 Brighton Road
Oakville, Ontario
L6H 6C9
Phone: +1-905 829 9533
Telefax: +1-905 829 9512

China

GRUNDFOS Pumps (Shanghai) Co. Ltd.
50/F Maxdo Center No. 8 Xingyi Rd.
Hongqiao development Zone
Shanghai 200336
PRC
Phone: +86-021-612 252 22
Telefax: +86-021-612 253 33

Croatia

GRUNDFOS CROATIA d.o.o.
Cebini 37, Buzin
HR-10010 Zagreb
Phone: +385 1 6595 400
Telefax: +385 1 6595 499
www.grundfos.hr

Czech Republic

GRUNDFOS s.r.o.
Čajkovského 21
779 00 Olomouc
Phone: +420-585-716 111
Telefax: +420-585-716 299

Denmark

GRUNDFOS DK A/S
Martin Bachs Vej 3
DK-8850 Bjerringbro
Tlf.: +45-87 50 50 50
Telefax: +45-87 50 51 51
E-mail: info_GDK@grundfos.com
www.grundfos.com/DK

Estonia

GRUNDFOS Pumps Eesti OÜ
Peterburi tee 92G
11415 Tallinn
Tel: + 372 606 1690
Fax: + 372 606 1691

Finland

OY GRUNDFOS Pumput AB
Mestarintie 11
FIN-01730 Vantaa
Phone: +358-3066 5650
Telefax: +358-3066 56550

France

Pompes GRUNDFOS Distribution S.A.
Parc d'Activités de Chesnes
57, rue de Malacombe
F-38290 St. Quentin Fallavier (Lyon)
Tél.: +33-4 74 82 15 15
Télécopie: +33-4 74 94 10 51

Germany

GRUNDFOS GMBH
Schlüterstr. 33
40699 Erkrath
Tel.: +49-(0) 211 929 69-0
Telefax: +49-(0) 211 929 69-3799
e-mail: infoservice@grundfos.de
Service in Deutschland:
e-mail: kundendienst@grundfos.de

Greece

GRUNDFOS Hellas A.E.B.E.
20th km. Athinon-Markopoulou Av.
P.O. Box 71
GR-19002 Peania
Phone: +0030-210-66 83 400
Telefax: +0030-210-66 46 273

Hong Kong

GRUNDFOS Pumps (Hong Kong) Ltd.
Unit 1, Ground floor
Siu Wai Industrial Centre
29-33 Wing Hong Street &
68 King Lam Street, Cheung Sha Wan
Kowloon
Phone: +852-27861706 / 27861741
Telefax: +852-27858664

Hungary

GRUNDFOS Hungária Kft.
Park u. 8
H-2045 Törökbálint,
Phone: +36-23 511 110
Telefax: +36-23 511 111

India

GRUNDFOS Pumps India Private Limited
118 Old Mahabalipuram Road
Thoraiakkam
Chennai 600 096
Phone: +91-44 2496 6800

Indonesia

PT GRUNDFOS Pompa
Jl. Rawa Sumur III, Blok III / CC-1
Kawasan Industri, Pulogadung
Jakarta 13930
Phone: +62-21-460 6909
Telefax: +62-21-460 6910 / 460 6901

Ireland

GRUNDFOS (Ireland) Ltd.
Unit A, Merrywell Business Park
Ballymount Road Lower
Dublin 12
Phone: +353-1-4089 800
Telefax: +353-1-4089 830

Italy

GRUNDFOS Pompe Italia S.r.l.
Via Gran Sasso 4
I-20060 Truccazzano (Milano)
Tel.: +39-02-95838112
Telefax: +39-02-95309290 / 95838461

Japan

GRUNDFOS Pumps K.K.
Gotanda Metalion Bldg., 5F,
5-21-15, Higashi-gotanda
Shiagawa-ku, Tokyo
141-0022 Japan
Phone: +81 35 448 1391
Telefax: +81 35 448 9619

Korea

GRUNDFOS Pumps Korea Ltd.
6th Floor, Aju Building 679-5
Yeoksam-dong, Kangnam-ku, 135-916
Seoul, Korea
Phone: +82-2-5317 600
Telefax: +82-2-5633 725

Latvia

SIA GRUNDFOS Pumps Latvia
Deglava biznesa centrs
Augusta Deglava ielā 60, LV-1035, Rīga,
Tālr.: + 371 714 9640, 7 149 641
Fakss: + 371 914 9646

Lithuania

GRUNDFOS Pumps UAB
Smolensko g. 6
LT-03201 Vilnius
Tel: + 370 52 395 430
Fax: + 370 52 395 431

Malaysia

GRUNDFOS Pumps Sdn. Bhd.
7 Jalan Peguam U1/25
Glenmarie Industrial Park
40150 Shah Alam
Selangor
Phone: +60-3-5569 2922
Telefax: +60-3-5569 2866

México

Bombas GRUNDFOS de México S.A. de
C.V.
Boulevard TLC No. 15
Parque Industrial Stiva Aeropuerto
Apodaca, N.L. 66600
Phone: +52-81-8144 4000
Telefax: +52-81-8144 4010

Netherlands

GRUNDFOS Netherlands
Veluwezoom 35
1326 AE Almere
Postbus 22015
1302 CA ALMERE
Tel.: +31-88-478 6336
Telefax: +31-88-478 6332
E-mail: info_gnl@grundfos.com

New Zealand

GRUNDFOS Pumps NZ Ltd.
17 Beatrice Tinsley Crescent
North Harbour Industrial Estate
Albany, Auckland
Phone: +64-9-415 3240
Telefax: +64-9-415 3250

Norway

GRUNDFOS Pumper A/S
Strømsveien 344
Postboks 235, Leirdal
N-1011 Oslo
Tlf.: +47-22 90 47 00
Telefax: +47-22 32 21 50

Poland

GRUNDFOS Pompy Sp. z o.o.
ul. Klonowa 23
Baranowo k. Poznania
PL-62-081 Przeźmierowo
Tel: (+48-61) 650 13 00
Fax: (+48-61) 650 13 50

Portugal

Bombas GRUNDFOS Portugal, S.A.
Rua Calvet de Magalhães, 241
Apartado 1079
P-2770-153 Paço de Arcos
Tel.: +351-21-440 76 00
Telefax: +351-21-440 76 90

România

GRUNDFOS Pompe România SRL
Bd. Biruintei, nr 103
Pantelimon county Ilfov
Phone: +40 21 200 4100
Telefax: +40 21 200 4101
E-mail: romania@grundfos.ro

Russia

ООО Грундфос
Россия, 109544 Москва, ул. Школьная
39
Тел. (+7) 495 737 30 00, 564 88 00
Факс (+7) 495 737 75 36, 564 88 11
E-mail grundfos.moscow@grundfos.com

Serbia

GRUNDFOS Predstavništvo Beograd
Dr. Milutina Ivkovića 2a/29
YU-11000 Beograd
Phone: +381 11 26 47 877 / 11 26 47 496
Telefax: +381 11 26 48 340

Singapore

GRUNDFOS (Singapore) Pte. Ltd.
24 Tuas West Road
Jurong Town
Singapore 638381
Phone: +65-6865 1222
Telefax: +65-6861 8402

Slovenia

GRUNDFOS d.o.o.
Štandrova 8b, SI-1231 Ljubljana-Črnuče
Phone: +386 1 568 0610
Telefax: +386 1 568 0619
E-mail: slovenia@grundfos.si

South Africa

Corner Mountjoy and George Allen Roads
Wilbart Ext. 2
Bedfordview 2008
Phone: (+27) 11 579 4800
Fax: (+27) 11 455 6066
E-mail: lsmart@grundfos.com

Spain

Bombas GRUNDFOS España S.A.
Camino de la Fuentequilla, s/n
E-28110 Algete (Madrid)
Tel.: +34-91-848 8800
Telefax: +34-91-628 0465

Sweden

GRUNDFOS AB
Box 333 (Lunnagårdsgatan 6)
431 24 Mölndal
Tel.: +46(0)771-32 23 00
Telefax: +46(0)31-331 94 60

Switzerland

GRUNDFOS Pumpen AG
Bruggacherstrasse 10
CH-8117 Fällanden/ZH
Tel.: +41-1-806 8111
Telefax: +41-1-806 8115

Taiwan

GRUNDFOS Pumps (Taiwan) Ltd.
7 Floor, 219 Min-Chuan Road
Taichung, Taiwan, R.O.C.
Phone: +886-4-2305 0868
Telefax: +886-4-2305 0878

Thailand

GRUNDFOS (Thailand) Ltd.
92 Chaloe Phrakiat Rama 9 Road,
Dokmai, Pravej, Bangkok 10250
Phone: +66-2-725 8999
Telefax: +66-2-725 8998

Turkey

GRUNDFOS POMPA San. ve Tic. Ltd. Sti.
Gebze Organize Sanayi Bölgesi
Ihsan dede Caddesi,
2. yol 200. Sokak No. 204
41490 Gebze/ Kocaeli
Phone: +90 - 262-679 7979
Telefax: +90 - 262-679 7905
E-mail: satis@grundfos.com

Ukraine

ТОВ ГРУНДФОС УКРАЇНА
01010 Київ, Вул. Московська 86,
Тел.: (+38 044) 390 40 50
Факс: (+38 044) 390 40 59
E-mail: ukraine@grundfos.com

United Arab Emirates

GRUNDFOS Gulf Distribution
P.O. Box 16768
Jebel Ali Free Zone
Dubai
Phone: +971-4- 8815 166
Telefax: +971-4-8815 136

United Kingdom

GRUNDFOS Pumps Ltd.
Grovebury Road
Leighton Buzzard/Beds. LU7 8TL
Phone: +44-1525-850000
Telefax: +44-1525-850011

U.S.A.

GRUNDFOS Pumps Corporation
17100 West 118th Terrace
Olathe, Kansas 66061
Phone: +1-913-227-3400
Telefax: +1-913-227-3500

Uzbekistan

Представительство ГРУНДФОС в
Ташкенте
700000 Ташкент ул.Усмана Носира 1-й
тулик 5
Телефон: (3712) 55-68-15
Факс: (3712) 53-36-35

97915704 0411

GB

ECM: 1073934

The name Grundfos, the Grundfos logo, and the payoff Be-Think-Innovate are registered trademarks owned by Grundfos Management A/S or Grundfos A/S, Denmark. All rights reserved worldwide.