



BUREAU OF FIRE PROTECTION

Agham Road, Barangay Bagong Pag-asa,
Diliman, Quezon City



FIRE SAFETY ENFORCEMENT MANUAL

2012 Edition

FIRE SAFETY ENFORCEMENT MANUAL

2012 Edition

FIRE SAFETY ENFORCEMENT DIVISION

Directorate for Fire Safety and Prevention

Bureau of Fire Protection

Barangay Bagong Pag-asa, Agham Road, Diliman,

Quezon City

www.bfpresponse.gov.ph

fsedbfpnhq@yahoo.com

Sources

RA 9514 otherwise known as the Fire Code of the Philippines of 2008

NFPA 10 2007 Edition

BFP Citizen's Charter

Essentials of Fire Fighting 4th Edition

ACKNOWLEDGEMENT

CSUPT DANILO R BARADI

SR SUPT IGMEDIO U BONDOC JR.

ENGR. MARIANO V JOSEPH JR.

INSP GEORGIAN DM PASCUA

INSP MARITES B UBAS

INSP RYAN C BOLITO

SFO2 MARLO SERITO

FO2 ARLENE DN MECINAS

FO2 DEXTER CERILLA

FO2 GIDEON GANDOLPOS

FO1 MARCIAL ALBARIDO JR

FO1 LORDJIM LUZA

FO1 NEYGEE ANGILOG

FO1 JENNYLYN LIM

FO1 MARICEL PINCA

FO1 JAYSON ELVIÑA

ENGR. BAYANI MENDOZA

FIRE SAFETY ENFORCEMENT MANUAL

2012 Edition

... in pursuit for service excellence!

GDM

GOLDEN RULES FOR FIRE SAFETY INSPECTORS

1. I shall wear my complete GOA, uniform every time I conduct inspection.
2. I shall introduce myself and present my inspection order to the building owner/occupant / administrator prior to the conduct of inspection.
3. I shall present myself in polite, courteous and professional manner at all times.
4. I shall only require the prescribed number of fire extinguisher and firefighting equipment to be placed in the building inspected.
5. I shall only inspect building/establishment indicated in the Inspection Order.
6. I shall act promptly on every request of the building administrators as far as fire safety is concern.
7. I shall strictly observe the proper guidelines in the conduct of fire safety inspection.
8. I shall furnish a copy of After Inspection Report to the building owner/administrator.
9. I shall ensure the taxes, fees and fines are properly assessed.
10. I shall always put in mind the safety of the occupants by providing fire safety assistance, i.e. distribution of fire safety materials or conducting lectures, while conducting inspection.



- a. Fire Code of the Philippines of 2008
- b. Amended Fire Code of the Philippines of 2008
- c. Comprehensive Fire Code of the Philippines of 2008
- d. Repealed Fire Code of the Philippines of 2008

ANSWER KEY								
1. a	2. b	3. b	4.d	5.d	6. b	7. b	8.d	9. b
10. c	11. a	12. a	13. c	14. b	15. c	16. a	17. a	18. a
19. b	20. c	21. c	22. c	23. c	24. d	25. a		

F
I
R
E
S
A
F
E
T
Y

M
A
N
U
A
L

PREFACE

The enactment of RA 9514 or the Fire Code of the Philippines of 2008 is a milestone in the history of the Bureau of Fire Protection. It has been a long dream of the BFP and it finally came into being. It serves as an effective tool of the BFP in achieving its mission and the realizing its vision.

The enforcement of the new Fire Code requires a comprehensive and thorough knowledge on the code in order to effectively and efficiently execute it. With the various memoranda, and guidelines crafted, our fire safety enforcers and other BFP personnel who are in the frontline services will be properly guided so as to observe the standard procedures in the implementation and enforcement of RA 9514. In the same manner, with the reports and data submitted by the field offices, it would be easy to monitor the implementation of the new Fire Code.

This new fire safety enforcement manual is anchored on the Fire Code of the Philippines of 2008 and its Implementing Rules and Regulations. It basically composes of the various issuances and circulars issued by the Chief, BFP and the SILG as far as the implementation and enforcement of the new Fire Code are concern. This manual will serve as the basic tool for our fire safety enforcers in the performance of their duties and responsibilities. The compilations attached are the significant documents that would address certain issues and concerns regarding the implementation of the code.

OFFICER IN CHARGE

I highly commend the officer and personnel of the Directorate for Fire Safety and Prevention for coming up with the Fire Safety Enforcement Manual. Indeed, this publication would help not only our fire safety officers but also the general public who may need clarification relative to the implementation of Republic Act 9514 or the new Fire Code of the Philippines of 2008.

Your laudable endeavor resonates your commitment and dedication in providing efficient and effective public service to our clientele. I encourage you to generate more innovative ideas to further enhance the Bureau's fire safety campaign.

Keep up the good work!

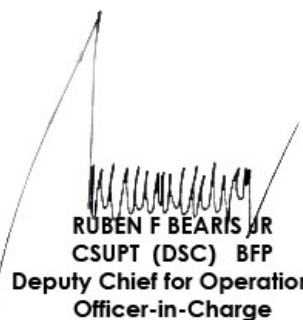

RUBEN F BEARIS JR
CSUPT (DSC) BFP
**Deputy Chief for Operations/
 Officer-in-Charge**

- a. No, the Fire Code does not provide any exemption from payment of fire code fees and taxes. Section 4 of RA 9514 provides that the provision of the fire code apply to all persons, private and public buildings constructed and erected before its effectivity.
- b. No, only public schools and local government units are exempted from paying fire drill fee.
- c. Yes, government agencies are exempted from paying fire drill fee as prescribed under Section 12.0.0.4 of the IRR of fire code of the Philippines.
- d. Yes, the Department of Agriculture has autonomy and therefore may not comply with other requirements of the law.

24. After the lapse of the prescribed period to comply provided for under the notice to correct violations. FO3 Dimalus Otan and FO3 Laging T Ama conducted a re-inspection on the apartment of Mr Matih Gasulo located at Diliman, Quezon City. Based on their submitted re-inspection report, no compliance was made by Mr Matih Gasulo. What should the City Fire Marshal do?

- a. Put up a sign in front of the building or structure that the building is a fire hazard, impose the corresponding administrative fines, and issue abatement order.
- b. Recommend the building for cancellation of its' business permit at the Business Licensing Office
- c. Furnish the BFP higher office of the re-inspection report submitted by the fire safety inspectors for their appropriate action.
- d. Request the building owner to execute affidavit of undertaking specifically thereof among others the period of completion of work.

25. RA 9514 is an act establishing a comprehensive fire code of the Philippines repealing Presidential Decree No. 1185 . The said act is also known as_____.

requested for an exemption for the installation of sprinkler system for the four storey residential building they started to construct in October 29, 2009 or before the effectivity of the Implementing Rules and Regulations of RA 9514. The plans and specifications of the building were approved based on the provisions of PD 1185 or the old fire code of the Philippines where sprinkler system for four storey residential building is not a mandatory requirement. Can the BFP grant the request exemption of Ma. Cecilia Ramos?

a. Yes, under Memorandum Circular Number 2011-06, all residential occupancies erected or constructed before the effectivity of RA 9514, including those buildings whose plans and specifications were approved based on the requirements of PD 1185 and are compliant with the fire safety requirements of PD 1185 are exempted from installing sprinkler system.

b. Yes, under Section 14.0.0.4 para. B of the IRR of RA 9514, the chief, BFP is given authority to exempt buildings erected before the effectivity of the IRR of RA 9514 which when forced to comply will compromise the structural integrity/stability of the building.

c. No, because the BFP has not yet issued FSIC for occupancy, besides there is still time to comply with the requirements of the new fire code of the Philippines. MC 2011-06 provides two years grace period for these existing establishments to fully comply with the fire safety requirements and measures under RA 9514 and its IRR.

d. No, RA 9514 and its IRR do not provide any authority for the Chief BFP to grant exemption. Further, Section 2 of RA 9514 provides that, the provisions of the Fire Code shall apply to all persons and all private and public buildings, facilities or structures erected or constructed before and after its effectivity.

23. The Department of Agriculture requested Quezon City Fire District to conduct fire drill in their office in Agham. The fire code fee assessor required them to pay 200 pesos for the fire drill. However, DA refuse to pay the 200 pesos fire drill fee citing that they are government agency and therefore exempted from paying such. Is the contention of DA proper?

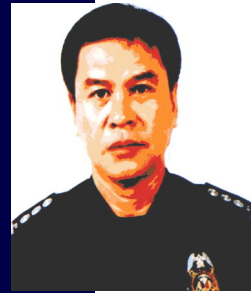

DIRECTOR FOR FIRE SAFETY AND PREVENTION

M E S S A G E

The long wait is over. The realization of our dream of becoming world-class and modern fire protection agency is just within our finger tips. We have now R.A. 9514, otherwise known as the Fire Code of Philippines 2008 that certainly guarantees bright future not only for us but also to the community, as it opens the gate of hope, the avenue of opportunity, and the boulevard of change.

However, no matter how we think that everything is perfect and everything is in its proper place, it is still difficult to attain the optimum. There will always be errors and shortcomings, but of course, a room to correct our mistakes and an option to strengthen our weaknesses.

It is for this reasons, that I would like to laud the people behind the conceptualization of this Fire Safety Enforcement Manual. This is again another unparalleled accomplishment. Through this, BFP personnel in the field will be guided accordingly and became a catalyst of a better Fire Bureau.

Congratulations for having a job well done!!!

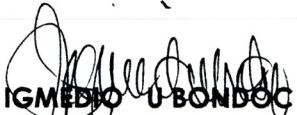
IGMADIO U-BONDOC JR, MPA
SSUPIT (DSC) BFP



**CHIEF, FIRE SAFETY
ENFORCEMENT DIVISION**

The promulgation of the Fire Code of the Philippines of 2008 has been a milestone of the BFP in its service to the community. The RA 9514 serves as our weapon in achieving our mandates.

The Office of the Fire Safety Enforcement Division in its enormous desire to effectively implement and enforce the Fire Code came up with this Fire Safety Manual which would serve as an additional tool for every BFP personnel in the field to efficiently and effectively perform their duties and functions.

It is with great pride and honour that I wish to congratulate my staff for their collaborative efforts and dedication that contributed much to make this project a success. This work and deed is worthy of praise and emulation.

Mabuhay!!!

ENGR. MARIANO V JOSEPH JR
Chief, Fire Safety Enforcement Division
BFP- National Headquarters

or structure that the building is fire hazard
 d. Recommend for cancellation of permit at the Department of Health

18. For purposes of determining required exits, the occupant load of business purposes shall be no less than one (1) person per _____ square meters of gross floor area.

- a. 9.3
- b. 9.2
- c. 9.1
- d. 9.4

19. According to the Implementing Rules and Regulations of the RA 9514, storage of fireworks and other pyrotechnics shall be in accordance with RA _____.

- a. 7182
- b. 7183
- c. 7138
- d. 7128

20. What are the instances where approved supervised sprinkler system becomes mandatory for residential occupancy?

- a. All residential occupancy regardless of height, occupant load and number of accommodation shall be protected by approved supervised sprinkler system.
- b. All residential buildings with three (3) storeys in height shall be provided with approved supervised sprinkler system.
- c. All residential building with four storeys or more in height shall be provided with approved supervised sprinkler system.
- d. none of the above.

21. When should the BFP impose administrative fines for buildings with violation?

- a. When during fire safety inspection, a violation is found/ noted.
- b. Upon issuance of notice to comply
- c. When after lapse of notice to comply and re-inspection shows no compliance was effected by the owner
- d. There is no administrative fine being imposed by the BFP

22. Ms. Ma. Cecilia A. Ramos, Proprietress of J-Par Construction

- (appearance of breathing)
- c. Smoke-stained windows
 - d. All of the above
6. It refers to the portion of a roadway or public way that should be kept open and unobstructed at all times for the expedient conduct of fire fighting operations.
- a. Fire Escape
 - b. Fire Lane
 - c. Fire Exit
 - d. Fire Protective Assembly
7. Which of the phrases about Assembly Occupancies is most appropriate?
- a. Assembly Occupancies include stores, markets, and other rooms buildings, or structures for the display and/or sale of merchandise.
 - b. Assembly Occupancies include, but not limited to, all buildings or portions of buildings used for gathering together of fifty (50) or more persons for such purposes as deliberation, worship, entertainment, eating, drinking, amusement, awaiting transportation, or similar uses.
 - c. Assembly Occupancies include all buildings or structures utilized primarily for sheltering of goods, merchandise, products, vehicles, or animals.
 - d. Assembly Occupancies refer to two or more classes of occupancies occurring/ located/situated/ existing in the same building and/or structures so intermingled that separate safeguards are impracticable.
8. Which type of occupancy a Gasoline Station belongs?
- a. Storage Occupancy
 - b. Industrial Occupancy
 - c. Miscellaneous Occupancy
 - d. Mercantile Occupancy
9. It refers to an act that would remove or neutralize a fire hazard.
- a. Fire Safety Inspection
 - b. Abatement
 - c. Issuance of Notice to Comply
 - d. Stoppage or Closure
10. It refers to alarm initiating device designed to actuate when visible or invisible products of combustion are present in the

TITLE	PAGE
Letter Reply to Ma. Consorcia L Tamayo Board Member, UPH-Jonelta System Perpetual Help Hospital of Manila	64
Requesting for 60-day extension to comply with the proposed alternative/remedial fire safety measures in lieu of automatic sprinkler system	
Letter Reply to Mr. Nepomuceno	66
Clarification on the basis for computing fire safety inspection fee.	
Letter reply to Atty Chito M. Cruz General Manager National Housing Authority	69
Seeking opinion/comment relative to the: (a) fire safety requirement under the fire code and, (b) on the Elevator Requirement, relative to the recommendation of DPWH on the optimum level of medium-rise buildings for the Informal Settler Families (ISFs) in Metro Manila.	
Department of Justice Secretary Opinion	72
Department of Justice's opinion on whether economic and socialized housing projects under Batas Pambansa (B.P. Blg. 220 are covered by Republic Act 9514 (the "Fire Code"), or whether they are exempt from the Automatic Fire Suppression System requirement, and Whether or not the height standard set for AFSS requirement is that of a four-storey (4-storey) or more building, or a fifteen-meter (15-meter) bar.	
CONVEYANCE CLEARANCE FORM	83
RELEVANT REGULATIONS ON FIRE EXTINGUISHER	86
- FIRE CODE PROVISIONS ON PORTABLE AND WHEELED FIRE EXTINGUISHERS	88
- SELECTION OF FIRE EXTINGUISHER	88
- DISTRIBUTION OF FIRE EXTINGUISHER	88

TITLE	PAGE
RELEVANT REGULATIONS ON FIRE EXTINGUISHER	
- ARRANGEMENT IN A BUILDING	91
MEANS OF EGRESS	95
- COMPONENT OF MEANS OF EGRESS	96
- CAPACITY OF MEANS OF EGRESS	97
- ARRANGEMENT OF MEANS OF EGRESS	100
- TRAVEL DISTANCE	101
- HEADROOM	102
- DOORS	103
- RAMPS	105
- FIRE ESCAPE STAIRS	106
- LADDER	107
FEATURES OF FIRE PROTECTION	108
TAKE A QUIZ	128
GOLDEN RULES FOR FIRE SAFETY INSPECTORS	137
AKNOWLEDGEMENT	138

FIRE SAFETY ENFORCEMENT EXAMINATION

Instruction: Choose the best answer of the following questions.

1. What are the four elements of fire tetrahedron?
 - a. Oxygen, fuel, heat and self-sustained chemical chain reaction
 - b. Air, fuel, heat and self-sustained chemical chain reaction
 - c. Air, fuel, gas and self-sustained chemical chain reaction
 - d. Oxygen, wood, heat and self-sustained chemical chain reaction
 - e. Oxygen, fuel, gas and self-sustained chemical chain reaction

2. It is the transfer of heat by the movement of heated fluids or gases, usually in upward direction?

a. Radiation	b. Convection
c. Conduction	d. Friction

3. Which of the following phrases about the classification of fire is true?
 - a. The primary mechanism of extinguishment when dealing with Class B fires is cooling to reduce the temperature of fuel to slow or stop the release of pyrolysis products.
 - b. Household appliances, computers, transformers, electric motors and overhead transmission lines are typical sources of Class C fires
 - c. No single agent effectively controls fire in all combustible liquids
 - d. Either b or c

4. It is the systematic removal of heated air, smoke, and fire gases from a burning building and replacing them with cooler air.

a. Overhauling	b. Rescue and Extrication
c. Fire Fighting	d. Ventilation

5. Which of the following phrases is a sign of a potential back-draft?
 - a. Pressurized smoke coming from small cracks
 - b. Smoke puffing at intervals from the building



Republic of the Philippines
DEPARTMENT OF THE INTERIOR AND LOCAL GOVERNMENT
BUREAU OF FIRE PROTECTION



Agham Road, Barangay Bagong Pag-Asa, Diliman, Quezon City
Tel. Number (02) 426-4399

MEMORAN DUM CIRCULAR

January 4, 2011

NUMBER : 2011-06

TO : ALL REGIONAL DIRECTORS AND PROVINCIAL, CITY AND MUNICIPAL FIRE MARSHALS

Re : SUPPLEMENTAL GUIDELINES FOR THE EFFECTIVE TRANSI-TORY COMPLIANCE FROM THE OLD FIRE CODE (PD1185) TO THE NEW FIRE CODE OF 2008 (RA9514) AMENDING SEC. 14.0.0.7 OF THE IMPLEMENTING RULES AND REGULATIONS OF RA 9514.

The passage of Republic Act No. 9514, otherwise known as the Fire Code of the Philippines of 2008, on 19 December 2008 was an enormous landmark for the Bureau of Fire Protection (BFP) considering that the old fire code, Presidential Decree Number 1185 had long been passed 26 August 1977, or thirty-one years ago.

RA 9514 ushers more of stringent provisions in pursuance of the State policy and this Department's mandate to further strengthen public safety and ensure the effective implementation of different measures on fire protection and prevention, detection and suppression. As a consequence, those existing private and public establishments, buildings, structures and facilities, occupancies and their premises or portion thereof ("occupancies" for brevity) deemed compliant under the old fire code are now non-compliant since the enactment of RA 9514 in 2008.

To address this peculiar situation and to allow reasonable period for these existing establishments to fully comply with the fire safety requirements and measures under RA 9514 and Its Implementing Rules and Regulations (IRR), Section 14.0.0.7 of IRR is hereby amended to read as follows:

TAKE A QUIZ
(Test your I.Q on Fire Safety)

“ Section 14.0.0.7

These implementing rules and regulations shall take effect 30 days after publication of the last installment in a newspaper of general circulation.

Transitory Clause. The owner, administrator or occupant of buildings or structures existing at the time of the effectivity of the RA 9514 and its IRR is given two (2) years to comply with the provisions of the requirements for Installation of Automatic Fire Suppression System (sprinkler system), provided, however, that the building or structures, must be compliant to the provisions on fire safety system and requirements of PD 1185 during the period of compliance”

ROLANDO M BANDILLA JR, CESO IV
 Director Chief, BFP

Approved by:

JESSE M. ROBREDO
 Secretary
 Republic of the Philippines
 DEPARTMENT OF THE INTERIOR
 AND LOCAL GOVERNMENT
 IN REPLYING, PLS CITE:
 SILG10-005371

Extinguishing Requirements

- All buildings shall be protected throughout by an approve, supervised sprinkler system except in buildings where all guest sleeping rooms or guest suites have a door opening directly outside at the street or grade level or exterior exit access in buildings up to and including three (3) storeys in height.

E. Mercantile

Definition

It include stores, markets, and other rooms, buildings, or structures for the display and/or sale of merchandise.

Examples

- Malls
- Supermarkets
- Department Stores
- Shopping Centers
- Flea Markets
- restaurants of less than 50 persons capacity;
- public/private dry and wet markets;
- water refilling stations;
- water refilling stations;
- hardwares/construction supplies;
- showrooms; and
- auction rooms

Occupant Load

TYPE OF OCCUPANCY	OCCUPANT LOAD FACTOR (square meters per person)
6. Mercantile	18.6

3. All corridors serving as access to exits at least a one (1) hour fire-resistance rating.

4. There is not more than 6.10 m of travel distance to reach an exit from entrance door of any living unit.

Exit Details

- Corridors with a required capacity of more than 50 persons shall be of sufficient width to accommodate the required occupant load but shall have a width of not less than 112 cm.
- Corridors with a required capacity of not more than 50 persons shall not be less than 91 cm.

Travel Distance

- Within any individual living unit to nearest exit = 15.50 m
- Entrance door to any apartment to an exit = 31 m if not sprinklered, 46 m if sprinklered

Discharge from Exits

- Discharge from exits shall be the same as required for hotels

Segregation of Dwellings

- Dwelling units in row apartments shall be separated from each other by partition walls having a fire resistance rating of four (4) hours. Such walls shall be constructed solidly and continuously from the ground to level one (1) meter above the ridge line of the roof.

Protection of Vertical Openings

Same as for hotels

Alarm System

- 4 or more storey in height or more than 12 units shall have automatic fire alarm and detection system
- 3 storeys or less shall be protected with manual fire alarm system, dwelling units shall be installed with single station or multi-station smoke detectors



Republic of the Philippines
DEPARTMENT OF THE INTERIOR AND LOCAL GOVERNMENT
Francisco Gold Condominium II
Edsa Cor. Mapagmahal St., Diliman
Quezon City

OFFICE OF THE SECRETARY

January 4, 2011

MEMORANDUM CIRCULAR

NUMBER: **2011-05**

TO : ALL REGIONAL DIRECTORS, PROVINCIAL, DISTRICT, CITY AND MUNICIPAL FIRE MARSHALS

SUBJECT : INTENSIFYING FIRE SAFETY ENFORCEMENT IN THE BUREAU OF FIRE PROTECTION AND INSTITUTIONALIZING STANDARD PROCESSES IN THE CONDUCT OF INSPECTION AND DEFINING ACCOUNTABILITIES OF CONCERNED BFP PERSONNEL IN THE INSPECTION AND ISSUANCE OF FIRE SAFETY INSPECTION CERTIFICATE

Ensuring public safety is a policy of the state and a mandate of this Department to which we adhere to the highest degree.

With report reaching this Department of violations relative to the issuance of Fire Safety Inspection Certificate (FSIC), you are hereby ordered to strictly enforce RA 9514 and its implementing rules and regulations on the matter of fire safety inspection and issuance of the FSIC and other clearances.

Henceforth, the following guidelines must be observed in the course of the fire safety inspection by the respective Fire Marshals of establishments, buildings, structures and facilities and occupancies ("occupancies" for brevity) within their territorial juris-

diction:

1. Fire safety inspection must be conducted promptly, ensuring that the fire safety requirements under Rule 10 of the Implementing Rules and Regulations (IRR) of RA 9514 are strictly complied with. No FSIC shall be issued without the full compliance to the provisions of Section 7 of RA 9514.
2. A routine fire safety inspection of all occupancies within their area of responsibility shall be conducted by the respective City/Municipal Fire Marshal or his authorized representative and shall ensure that all inspection shall have been completed before the end of the year. The City/Municipal Fire Marshal shall ensure that an inspection is actually conducted as he is the primary official responsible, therefore in the event of any failure or lapses to conduct the same. Thereafter, an accomplishment report shall be made by the City/Municipal Fire Marshal to his immediate superior and indicating thereat those who are compliant and those who have violations. No FSIC shall be issued if no inspection has been made.
3. In addition to "Notice to Comply/Notice to Correct Violations" to the erring occupancies, the City/Municipal Fire Marshal shall then issue written report notifying the Local Chief Executive wherein all the local names of non-compliant establishments are listed, and expressly stating therein a recommendation not to issue any of the following permits, or revoke existing ones, when applicable—Business or Mayor's Permit, Permit to Operate, Occupancy Permit, PHILHEALTH Accreditation for Hospitals, DOH License to Operate, and other licenses being issued by the local government unit (LGU). The written notice to the LGU must be submitted within the seven (7) calendar days following the last month of the quarter when inspection is conducted.
4. For all occupancies, specially residential, storage, health care and public assembly occupancy, the Provincial/District Fire Marshal shall conduct a bi-annual audit by making actual verification and examination

Subdivision of Building Spaces

No Sprinkler

Separation of rooms shall be at least 1 hour fire resistance rating

With Sprinkler

Separation shall be at least ½ hour

Apartment Buildings (Section 10.2.12.4)

Exit Details

- Every living unit shall have access to at least two (2) separate exits.

Exception 1: Any living unit, which has an exit directly to the street or yard at ground level or by way of an outside stairway that serve a maximum of two units or an enclosed stairway with fire-resistance rating of one (1) hour or more serving that apartment only and not communicating with any floor below the floor of exit discharge or other area not a part of the apartment served, may have a single exit.

Exception 2: Apartment buildings of not more than three storeys in height with not more than six (6) living units per floor, with a smokeproof enclosure or an outside stairway as the exit, immediately accessible to all apartments served thereby, may have a single exit.

Exception 3: Any building not more than three (3) storeys in height with no floor below the floor of exit discharge or, in case there is such a floor, with the street floor construction of at least one-hour fire resistance, may have a single exit, under the following conditions:

1. The stairway is completely enclosed with a partition having a fire resistance rating of at least one (1) hour with self-closing fire doors protecting all openings between the stairway enclosed and the building.
2. The stairway does not serve any floor below the floor of exit discharge,

Fire Detection and Alarm Systems

- a. An automatic fire detection and alarm system shall be provided for any hotel or dormitory having accommodations for fifteen (15) or more guests. For less than 15 guests, a manual fire alarm system shall be installed.
- b. Every sounding device shall be of such character and so located as to arouse all occupants of the building or section thereof endangered by fire.
- c. An alarm-sending station and manual fire alarm box shall be provided at the hotel desk or other convenient central control point under continuous supervision of responsible employees.
- d. Suitable facilities shall be provided for immediate notification of the BFP.
- e. Positive fire alarm sequence may be permitted.
- f. Hotels and dormitories including its guest rooms and guests suites shall be required to be equipped with both audible and visible notification appliance.
- g. In hotels and dormitories not equipped with automatic fire detection and alarm system, guest rooms, living area and sleeping rooms within a guest suite shall be installed with single-station smoke detectors.

Protection of Vertical Openings

- Any required exit stair which is so located that it is necessary to pass through the lobby or other open space to reach the outside of the building shall be continuously enclosed down to the lobby level.
- No floor below the floor of exit discharge, used only for storage, heating requirements, or other than hotel occupancy open to guest or the public, shall have unprotected openings to floors used for hotel purposes.

Extinguishing Requirements

- All buildings shall be protected throughout by an approve, supervised sprinkler system except in buildings where all guest sleeping rooms or guest suites have a door opening directly outside at the street or grade level or exterior exit access in buildings up to and including three (3) storeys in height.

that the fire safety inspection reports submitted by the City/Municipal Fire Marshals are in accordance with the provisions of RA 9514 and its IRR. Any finding derived from the audit shall be indicated in the written bi-annual report submitted to the Regional Director. The same period of inspection and report mentioned in the preceding paragraphs applies in the conduct of audit and actual verification. The Provincial/District Fire Marshal shall be primarily accountable for failure to conduct the requisite audit subject of this provision.

5. All bi-annual reports furnish to the Regional Director shall be submitted to the Chief, BFP who is under obligation to make the same report to the Secretary of this Department.
6. The foregoing guidelines are mandatory in nature and any violation committed by the responsible officials mentioned herein shall be meted with penalties set forth in Section 11 (2) and sub-articles of RA 9514.
7. This Memorandum Circular shall take effect immediately.

For strict compliance.

JESSE M. ROBREDO
Secretary





REPUBLIC OF THE PHILIPPINES
DEPARTMENT OF THE INTERIOR AND LOCAL GOVERNMENT

Francisco Gold Condominium II
EDSA Cor. Mapagmahal St., Diliman
Quezon City

MEMORANDUM CIRCULAR

NUMBER: 2010-017

**SUBJECT: GUIDELINES IN THE APPROVAL OF ALTERNATIVE
AND/OR REMEDIAL FIRE SAFETY MEASURES**

I. GENERAL

Pursuant to Section 10 (c) and 54 of Republic Act (RA) 6975 and Section 5 of Republic Act (RA) 9514 otherwise known as The Fire Code of the Philippine of 2008, and in compliance with Section 14.0.0.3 of its Implementing Rules and Regulations (IRR), these guidelines are hereby prescribed to promote public safety relative to application and approval/acceptance of Alternative and/or Remedial Fire Safety Measures for existing public or private buildings, facilities or structures and their premises or portion thereof.

II. SCOPE

These Implementing Guidelines shall apply to all existing private or public buildings, facilities or structures and their premises or portion thereof erected or constructed before the effectivity of RA 9514 and its IRR, where compliance with the fire safety requirements as specified in the IRR of RA 9514 will compromise the structural stability/integrity of the said buildings, facilities or structures which necessitates Alternative and/or Remedial Fire Safety Measures.

These also apply to existing public and private buildings, facilities, structures and their premises or portion thereof granted

Travel Distance

- From the door of any room to nearest exit = 30 meters
- Within guest suite or room to corridor door = 23 m if no AFSS, 38 with AFSS

Discharge from Exits

- At least half of the required number of units of exit from upper floors, exclusive of horizontal exits, shall load directly to the street or through a yard, court, or passageway with protected openings and separated from all parts of the interior of the buildings.
- A maximum of fifty percent (50%) of the exits may discharge through areas on the floor of exit discharge provided:
 1. Such exits discharge to a free and unobstructed way to the exterior of the building, which way is readily visible and identifiable from the point of discharge from the exit.
 2. The floor of discharge into which the exit discharge is provided with AFSS and any other portion of the level of discharge with access to the discharge area is provided with AFSS or separated from it in accordance with the requirements for the enclosure of exit.
 3. The entire area on the floor of discharge is separated from areas below by construction having a minimum fire-resistance rating of two (2) hours.

Protection of Guest Rooms

- a. In any new hotel building every corridor shall be separated from guest rooms by partitions having at least a one (1) hour fire resistance rating.
- b. Each guest room shall be provided with a door having a fire protection rating at least twenty (20) minutes.
- c. Openings in corridor partitions other than door openings shall be prohibited.
- d. Doors that open directly onto exit access corridors shall be self-closing and self-latching.

- D. **Lodging or Rooming Houses** – includes building in which separate sleeping rooms are rented providing sleeping accommodations for a total of fifteen (15) or less persons, on either a transient or permanent basis; with or without meals, but without separate cooking facilities for individual occupants.
- E. **Single-and-Two Family Dwellings** – includes detached dwellings in which each living unit is occupied by members of a single family.

Occupant Load (Section 10.2.12.2 para A)

TYPE OF OCCUPANCY	OCCUPANT LOAD FACTOR (square meters per person)
5. Residential	18.6

Requirements (Section 10.2.12.2)

- No residential occupancy shall have its means of egress pass through any nonresidential occupancy in the same building,

Except:

In buildings with approved, supervised sprinkler system provided that the means of egress shall not pass through a high hazard content and the means of egress shall be separated by a construction of not less than 1 hour.

Hotels and Dormitories (Section 10.2.12.3)

Exits details

- Corridors, other than those in within individual guest rooms or individual guest suites, shall be of sufficient width to accommodate the required occupant load and shall not be less than 112 cm.

with Certificate of Exemption to install Automatic Fire Sprinkler System (AFSS) by the Chief, Bureau of Fire Protection (BFP) and/or the Director General of the Philippine Constabulary/Integrated National Police (PC/INP) under Presidential Decree No. 1185.

III. OBJECTIVE

- A. To prescribe guidelines in the application and approval of Alternative and/or Remedial Fire Safety Measures.
- B. To rationalize the selection or identification of appropriate Alternative and/or Remedial Fire Safety Measures in lieu of the fire safety requirements for installation of AFSS to existing public or private buildings, structure or facilities and their premises or portion thereof.
- C. To establish the procedure to be followed by the line units of the BFP prior to the final action of the Chief, BFP.

IV DEFINITION OF TERMS

1. **Republic Act 9514** – The Fire Code of the Philippines of 2008 amending Presidential Decree 1185.
2. **Automatic Fire Suppression System**- an integrated system of underground or overhead piping connected to a source of extinguishing agent or medium, designed in accordance with fire protection engineering standards to include, but not limited to Automatic Fire Sprinkler System which when actuated by its automatic detecting device suppresses fire within the area protected even without human intervention.
3. **Approved Supervised Sprinkler System (ASSS)** - an integrated network of hydraulically designed piping system installed in a building, structure or facility with outlets arranged in a systematic pattern. It automatically discharges water when activated by heat or combustion products of fire.
4. **Alternative and/or Remedial Fire Safety Measures**- set of fire safety rules, regulations, and standards specifically applied to existing public or private buildings, structures or facilities and their premises or portion thereof constructed or erected prior to the implemen-

tation of RA 9514, which has no existing ASSS required under the said law.

5. Fire Safety Technical Committee- a group created to evaluate and recommend appropriate action relative to application for Alternative and/ or Remedial Fire Safety Measures.

V. AUTHORITY TO GRANT APPROVAL/ACCEPTANCE

Pursuant to Section 4.0.0.4 of the IRR of RA 9514, only the Chief, BFP may approve the Alternative and/or Remedial Fire Safety Measures in lieu of the fire safety requirements in the installation of AFSS to existing public or private buildings, facilities or structures and their premises or portion thereof constructed or erected prior to the implementation of RA 9514, provided that any aggrieved party may appeal to the Secretary, DILG.

VI. PROCEDURES

A. Requirements of the Application

All applications for Alternative and/or Remedial Fire Safety Measures in lieu of the fire safety requirements pursuant to section 14.0.0.4 of the IRR of R.A 9514 shall be supported by the following documents:

1. Letter request stating the reason/s for applying Alternative and/or Remedial Measures in lieu of the fire safety requirements in the installation of ASSS.
2. As-built plans certified by Architect or Civil Engineer showing among others, the fire exits, floor and/or location of the fire hose, standpipes, valves, fire alarm bells, call points, switch boxes, fire extinguishers, smoke and heat detectors, emergency lights and source of power and water, and other fire safety requirements.
3. Certified true copies of the building and/or renovation, and Occupancy Permits (OP) issued by the Building Official.
4. Certified true copies of Fire Safety Correction Sheet/ Checklist/Clearance and Fire Safety Inspection Certifi-

accommodations.

Examples

1. Hotels
2. Motels
3. Apartelles
4. Pension Houses
5. Inns
6. Apartments
7. Condominiums
8. Dormitories
9. Lodging or rooming houses
10. one- and two-family dwellings

Classification (Section 10.2.12.1)

- A. **Hotels** – includes buildings or groups of building under the same management in which there are more than fifteen (15) sleeping accommodations for hire, primarily used by transients who are lodged with or without meals, whether designated as a hotel, inn, motel, or by any other name. So called appartelle, condotel or pension houses shall be classified as hotels, because they are potentially subject to transient occupancy like that of hotels.
- B. **Dormitories** – includes buildings where group sleeping accommodation are provided for persons, not members of the same family group in one room or in series of closely associated room under joint occupancy and single management, as in college dormitories, convents, fraternity houses, military barracks, and the like.
- C. **Apartment Buildings** – includes buildings containing three (3) or more living units independent cooking and bathroom facilities, whether designated as condominium, row house, apartment house, tenement, garden apartment, or by any other name.

any wall.

- Shall be interconnected to the alarm system.

Extinguishment (Section 10.2.10.3 para F)

- Approved, supervised sprinkler system shall be provided throughout all hospitals, nursing homes, and residential-custodial care facilities.
- Shall be electrically interconnected with the fire alarm system.
- Control valve shall be electrically monitored so that at least a local alarm will sound when the valve is closed.

Hazardous Areas (Section 10.2.10.3 para G)

- Any hazardous area shall be segregated and protected in accordance with Section 10.2.6.8 of this IRR. Hazardous areas include, but are not limited to the following:

1. Boiler and heater rooms

2. Laundries

3. Kitchens

4. Handicraft shops

5. Repair shops

6. Employee locker rooms

7. Soiled linen rooms

8. Paint shops

9. Rooms or spaces, including shops, used for the

storage of combustible supplies and equipment in quantities deemed hazardous by the Chief, BFP or his duly authorized representative.

10. Trash collection rooms

11. Gift shops

D. Residential

Definition

- Are those occupancies in which sleeping accommodations are provided for normal residential purposes and include all buildings designed to provide sleeping

cate (FSIC) (if any) from the Office of the City/Municipal Fire Marshal (OC/MFM).

5. Certified true copy of the latest Fire Safety Inspection Report (FSIR) or Notice to Comply and/or Notice to Correct Violation (NTC/ NTCV).
6. Certification from Structural Engineer, preferably a member of the Associations of Structural Engineers of the Philippines (ASEP), declaring that the said buildings, facilities or structures cannot support additional load for the installation of ASSS.
7. Proposed Alternative and/or Remedial Fire Safety Measures, including designs and specifications, to be installed and/or constructed in lieu of the fire safety requirements, duly certified by Qualified Technical Personnel/ Fire Safety Engineer/ FALAR Practitioners and approved by the owner/authorized representative.
8. Copy of Fire Safety and Prevention Program (Fire Brigade Organization) including evaluation plan certified by the Chief, Fire Brigade/Chief Safety Officer of the buildings, facilities or structures concerned and approved by the owner/authorized representative.
9. Current Certificate of Fire Drill issued by OC/MFM.
10. Affidavit of Undertaking absolving the BFP from any criminal/administrative liability in case of fire and fire related deaths and injuries.

Note: Photocopied documents shall be certified true copy by the authorized official of the issuing office.

B. Processing and Approval of Application

1. All applications for Alternative and/or Remedial Fire Safety Measures together with the required documents shall be submitted to the OC/MFM concerned for pre-evaluation and endorsement to the BFP Regional Director thru the District/Provincial Fire Marshals

D/PFM).

2. The Office of the Regional Director concerned shall evaluate the application and recommend appropriate action (re approval/disapproval) before endorsing the same to the Chief, BFP (ATTN: Chairperson, Fire Safety Technical Committee (FSTC)).
3. The Chairperson of the FSTC or his authorized representative shall conduct physical inspection of the existing public or private buildings, facilities or structure and their premises or portion thereof being applied for and evaluate the proposed Alternative and/or Remedial Fire Safety Measures presented.
4. The inspection and evaluation reports, together with the application and supporting documents, shall be carefully evaluated and deliberated by the FSTC and thereafter recommend the approval/disapproval of the application by the Chief, BFP.
5. Approved proposed Alternative and/or Remedial Fire Safety Measure shall be properly issued with corresponding Bureau Order enumerating among others the name of the building, facility or structure, location/address, owner/administrator, the Alternative and/or Remedial Fire Safety Measures to be installed/constructed in lieu of the fire safety requirement and the condition of its approval (i.e. grace period to install/construct the alternative and/or remedial fire safety measure, observance of fire safety requirements, etc). Disapproved proposal shall be referred back to the Regional Director concerned for subsequent information to the owner/representative.

C. Issuance of Certificate of Exemption

1. Upon completion of the installation and/or construction of the Alternative and/or Remedial Fire Safety Measures, the owner/representative shall formally request the OC/MFM concerned for an inspection of the completed fire safety measures.

exceeding 0.46 m² in steel frames shall be provided in all doors in

TYPE OF OCCUPANCY	OCCUPANT LOAD FACTOR (square meters per person)
Health Care a. sleeping departments b. inpatient treatment departments	 11.1 22.3

smoke partitions.

- Stops are required on the head and sides of door frames in smoke partitions and center mullions are prohibited.

Protection of Vertical Opening

- Any stairway, ramp, elevator shaft, light and ventilation shaft, chute and other openings between storeys shall be enclosed with noncombustible materials.
- A door in a stairway enclosure shall be self-closing, shall normally be kept in closed position.

Alarm Systems (Section 10.2.10.3 para F)

- Every building shall have an electrically supervised automatic fire alarm system capable of being manually operated.
- Fire alarm system shall be installed with provisions for future connection to the nearest BFP station.

Detection System (Section 10.2.10.3 para F)

- automatic heat and/or smoke detection system shall be installed in all corridors of hospitals, nursing homes, and residential-custodial care facilities.
- in no case shall smoke detectors be spaced further apart than 9 m on centers or more than 4.60 m from

- Exit access doors from hospital sleeping rooms, diagnostic and treatment rooms or areas such as X-ray, surgery and physical therapy, all doors between these spaces and the required exits, and all exit doors serving these spaces shall be at least 112 cm. Doors to residential-custodial sleeping rooms and door to nursing sleeping rooms and all exit doors serving these spaces shall be at least 91 cm wide.

Each of the following systems shall be so arranged as to initiate the self-closing action throughout the entire health care facility.

- a. The required alarm system;
- b. The required automatic fire detection system; and
- c. An approved automatic fire suppression system.

Protection (Section 10.2.10.3)

Subdivision of Building Spaces

- Smoke partitions shall be provided, regardless of building construction type, as follows:

- a. To divide into at least two (2) compartments every storey used by inpatients for sleeping or treatment and any storey having an occupant load of fifty (50) or more persons.
- b. maximum area of each smoke compartment to no more than 2,100 m², of which both length and width shall be no more than 46 m.

- Smoke partitions shall be provided on storeys which are usable but unoccupied.

- Any smoke partition shall be constructed in accordance with Section 10.2.6.9 of the IRR and shall have a fire resistance rating of at least one (1) hour.

- Corridor openings in smoke partitions shall be protected by a pair of swinging doors, door to swing in a direction opposite from the other. The minimum width of each door for hospitals and nursing homes shall 112 cm, while that for residential-custodial care institutions shall be 81 cm.

- Vision panels of approved transparent wired glass not

2. An inspection will be conducted by the OC/MFM concerned and endorse its findings to the Office of the Regional Director concerned, thru the D/PFM.
3. The Office of the Regional Director concerned shall evaluate findings and recommend appropriate action (re: approval/disapproval) to the C, BFP (ATTN: Chairperson, FSTC).
4. The Chairperson of the FSTC or his authorized representative shall conduct physical inspection of the existing public or private buildings, facilities or structures and their premises or portion thereof to evaluate compliance with the approved Alternative and/or Remedial Fire Safety Measures.
5. The inspection and evaluation reports shall be deliberated upon by the FSTC. The result of the deliberation will be the basis of the recommendation for the approval/disapproval of the Chief, BFP.
6. Upon approval, a corresponding certificate in the form of Bureau Order shall be issued by the Chief, BFP enumerating among others, the name of building, facility or structure; address/location; owner/administrator; the Alternative and/or Remedial Fire Safety Measures installed/constructed in lieu of fire safety requirement; and the condition of approval/acceptance. Disapproved application shall be referred back to the Office of the Regional Director concerned for subsequent information to the concerned owner/representative.
7. After compliance of the required Alternative and/or Remedial Fire Safety Measures and the corresponding certificate of approval by the Chief, BFP, FSIC may now be issued by the concerned OC/MFM.

VII. ALTERNATIVE AND/OR REMEDIAL FIRE SAFETY MEASURES

A. Fire Safety Construction

1. All interior partitions must be made of fire resistive materials including parts or components, extending from

slab to slab.

2. Rooms, vertical and horizontal openings or parts thereof must be totally enclosed.
3. All pipes chase must be constructed with fire collar or fitted with sealant.
4. All exposed steel structure components must be covered/coated with fire resistive materials to protect its structural stability during conflagration.
5. All firewalls must be extended 20% more from the established standard requirement.
6. All other fire safety construction components must be constructed in accordance with established standard requirement for any type of occupancy.

B. Occupancy Load

1. Actual occupant load and egress capacity for all kinds of occupancies must not exceed the established occupant load standard for any type of occupancy.

C. Fire Protection

1. Installation of any or all the following pre-engineered suppression systems:
 - a. Ceiling Type Fire Suppression System using other extinguishing agents with automatic heat and smoke detection.
 - b. Liquefied Gaseous Fire Suppression System in high hazard areas within the building premises or structure.
2. Installation/Provision of portable fire protection (fire extinguisher) for the different types of hazard in any type of occupancy shall be increased by 20% from the standard requirements.
3. Provision/Installation of dry and wet standpipe. Wet

Defend-in-place strategy

- Proper design, construction and compartmentation
- Provision for detection, alarm and extinguishment;
- Fire prevention and the planning, training and drilling in programs for the isolation of fire and transfer of occupants to areas of refuge or evacuation of building.

ER, OR, ICU, DR (Section 10.2.10.1 para C)

- ER, OR, ICU, DR and other similar facilities shall not be located at the 2nd Floor or basement. For existing it shall be provided with ramps.

Occupant Load (Section 10.2.10.1 para E)

Exit Details (Section 10.2.10.2)

Travel Distance

- any room door and an exit = 30 meters
- any point in a room and an exit = 46 meters
- any point in a room or suite and an exit access door of the room or suite = 15 meters
- Aisles, corridors and ramps shall not be less than 244 cm. Suite or rooms of more than 93 m² shall have at least two exit doors remote from each other.

Doors

Locks shall not be permitted on patient sleeping room doors.

Exception No. 1: Key-locking devices that restrict access to the room from the corridor and that are operable only by staff from the corridor side shall be permitted. Such devices shall not restrict egress from the room.

Exception No. 2: Door-locking arrangements shall be permitted in health care occupancies, or portions of health care occupancies, where the clinical needs of the patients require specialized security measures for their safety, provided that keys are carried by staff at all times.

Exit Details (Section 10.2.10.2)

- If protected with AFSS the operation of the system shall automatically actuate electrical school's fire alarm system.

Automatic Fire Suppression System

Every portion of educational buildings below the floor of exit discharge shall be protected with complete automatic sprinkler protection .

Hazardous Areas

Separated from other parts of the building with construction having not less than a 1 hour fire resistance rating and all openings shall be protected with self-closing fire doors or shall be provided with AFSS .

Cooking Equipment

Cooking equipment shall be protected by automatic kitchen hood fire suppression.

Special Provision for Pre-Schools (Section 10.2.9.8)

Rooms used for pre-schoolers, first grade and second grade pupils shall not be located above or below the floor of exit discharge.

C. Health Care

Definition

Used for purposes of medical or other treatment or care of persons where such occupants are mostly incapable of self preservation because of age, physical or mental disability, or because of security measures not under the occupants' control.

- Hospitals
- Nursing Homes
- Birth Centers
- Residential custodial care centers such as nurseries, homes for the aged and the like.

Fundamental Requirements (Section 10.2.10.1 para B)

standpipe must be operational with fire keys and not through gravity or overhead tanks.

4. Installation of automatic alarm and signaling system according to established standards.

D. Means of Egress (Exit Details)

1. Provision/Construction of a minimum of two (2) secondary fire exits, remote from each other, with travel distance of 20% less from the standard requirements.
2. Installation/Provision of all the following in the secondary exits, to wit:
 - a. Fire resistive door with panic hardware.
 - b. Self-closing fire door with minimum width of 20% more from standard requirement.
 - c. Battery-operated emergency light in all of the stair landings.
 - d. Termination of all exits to public egress, continuous and unobstructed at all times.
3. All fire exits must be mechanically pressurized.
4. Installation of illuminated exit signs in conspicuous place leading to emergency exits.

E. Fire Safety and Prevention Programs

1. Creation of fire brigade organization with Certificate of Competency (COC) of members issued by the BFP.
2. Compulsory attendance for all members of the fire brigade in all fire safety seminars conducted in the building, facility or structure.
3. Conduct of fire evacuation drill quarterly with corresponding certification issued by the OC/MFM concerned.

4. Compulsory attendance of all occupants to at least two (2) fire safety seminars in the building annually.
5. Compulsory briefing/orientation of all new tenants and/or occupants on fire safety program of the building within one (1) month upon regular employment in any office/business within the building, facility or structure.

VIII. GRACE PERIOD

The owner/administrator/occupant shall complete the construction/renovation of the building, facility or structure including the installation and final testing of fire protection and warning systems and other requirements in the approved application within six (6) months from the date of approval of the proposed Alternative and/or Remedial Fire Safety Measure, provided, that a duly notarized Affidavit of Undertaking shall be executed by the owner or his authorized representative stating compliance with the conditions set, notwithstanding appropriate measures undertaken to ensure reasonable fire safety during compliance.

IX. REPEALING CLAUSE

All directives, issuances, memoranda inconsistent with this Memorandum Circular are hereby repealed or amended accordingly.

Certificates of Exemption on the installation of Automatic Fire Suppression System (sprinkler system) issued prior to this Memorandum Circular, except those eligible Certificates of Exemption with corresponding BFP Order or PC/INP Order, signed and issued by the Chief, BFP or Director General, PC/INP, respectively, are hereby nullified. However, all eligible Certificates of Exemption issued earlier are subject to review/ renewal within sixty (60) days upon effectivity of this Memorandum Circular.

Any interior stairways and other vertical openings in educational buildings shall be enclosed and protected except :

- When it serves only one adjacent floor other than a basement,
- It is not connected to other stairway serving other floor
- It is not connected with corridors or stairways serving other floors.

Protection (Section 10.2.9.5)

Interior Corridors

- constructed of not less than ½ hour fire resistance rating and all openings therein protected accordingly
- room doors may be 44 mm solid bonded core wood doors or the equivalent.

Except:

When all classrooms served by such corridors have at least one door directly to the outside or to an exterior

TYPE OF OCCUPANCY	OCCUPANT LOAD FACTOR (square meters per person)
Educational a.net classroom area b.net area of shops, laboratories and similar vocational rooms	 1.9 4.6

balcony.

Fire Alarm System

- Approved fire alarm facilities capable of being manually operated shall be provided in every educational building.

Exit Details (Section 10.2.9.2)

Minimum Number of Exits

- Room or space with OL of 50 or more persons shall have at least two doorways

Access to Exit

- Minimum corridor width = 1.83 m

Exit Arrangement

- Dead – end corridor shall not extend more than 6 m
- Classrooms located at the basement shall have access to at least 1 exit that leads directly to the exterior without entering the floor above

Additional Exit Details

- Educational buildings used by persons with physical or mental handicaps shall have additional features as may be required by the Chief, BFP or his duly authorized representatives.

Windows for Rescue and Ventilation (Section 10.2.9.4)

1. It can readily be opened from the inside without the use of tools.
2. It provides a clear opening with a minimum dimension of 560 mm in width and 800 mm in height.
3. The bottom of window opening is not more than eighty two (82)centimeters above the floor;
4. Where storm windows, screens, or anti-burglar devices are used, these shall be provided with quick opening mechanism so that they may be readily opened from the inside for emergency egress and shall be so arranged that when opened they will not drop to the ground.

Protection (Section 10.2.9.5)

Vertical Openings

X. EFFECTIVITY

This Memorandum Circular shall take effect immediately.

ROLANDO M. BANDILLA JR, CESO IV
DIRECTOR BFP
Chief, BFP

BY AUTHORITY OF THE SECRETARY, DILG:

ATTY. MARIUS P. CORPUS

Undersecretary for Public Safety



Republic of the Philippines
DEPARTMENT OF THE INTERIOR AND LOCAL GOVERNMENT
Francisco Gold Condominium
EDSA Cor. Mapagmahal St., Diliman Quezon City

MEMORANDUM CIRCULAR NUMBER: 2012-06

FOR : LOCAL CHIEF EXECUTIVES, CITY TREASURERS AND OTHER CONCERNED LOCAL GOVERNMENT OFFICIALS AND WITHIN THE NATIONAL CAPITAL REGION

SUBJECT : COLLECTION OF FIRE CODE REVENUES

DATE : 09 JANUARY 2011

In view of the necessity of maximizing the resources of the Bureau of Fire Protection (hereinafter referred to as "BFP", for brevity) in accordance with Republic Act No. 9514 and its Implementing Rules and Regulations, all government officials within the National Capital Region (hereinafter referred to as "NCR", for brevity) are hereby directed to recognize the authority of the BFP in the assessment and collection of the Fire Code Revenues, particularly the FIRE SAFETY INSPECTION FEE.

The authority of the BFP in the assessment and collection of the Fire Code Revenues is clearly granted in Section 13 and Section 13-A of Republic Act No 9514, otherwise known as the "Fire Code of the Philippines of 2008", to wit:

" Section 13. Collection of Taxes, Fees and Fines— All taxes, fees and fines provided in this Code shall be collected by the BFP: Provided, that twenty percent (20%) of all such collections shall be set aside and retained for use by the city of municipal government concerned, which shall appropriate the same exclusively for the use of the operation and maintenance of its local fire station, including the construction and repair of fire station: Provided, further, that the remaining eighty percent (80%) shall be remitted to the National Treasury under a trust fund assigned for the modernization of the BFP.

Building Service Equipment (Section 10.2.8.9)

- Cooking equipment shall be protected by automatic kitchen hood fire suppression

Plan of Exit Ways (Section 10.2.8.10)

- A plan showing the capacity and location of the exit ways and aisles shall be submitted for approval by the C/MFM and approved copy of such plans shall be kept prominently on display in the premises.

Overcrowding (Section 10.2.8.11)

- The C/MFM upon finding any overcrowding condition or obstructions in aisles, passageways or other means of egress; or upon finding any condition which constitutes a serious menace to life, shall cause the performance, presentation or entertainment to be stopped until the condition or obstruction is corrected.

B. Educational Occupancies

Definition (Division 3, Chapter 2, Rule 10)

- All buildings or portions thereof used for the gathering of group of six (6) or more persons for purposes of instruction.

Examples

- School
- Universities
- Colleges
- Academies
- Nursery schools
- Kindergartens
- Child care facilities

Occupant Load (Section 10.2.9.1 para B)

- For nurseries for sleeping quarters = 3.3 sq. meters per person
- For areas with fixed seats = no. of fixed seats

c. in case of assembly occupancy located below the level of exit discharge, throughout all storeys intervening between that storey and the level of exit discharge.

TYPE OF OCCUPANCY	OCCUPANT LOAD FACTOR (square meters per person)
Assembly	
a. concentrated use without fixed seats	0.65
b. less concentrated use	1.4
c. standing room or waiting space	0.28

Exemption (Section 10.2.8.8 para E no. 3)

- Single multipurpose room of less than 1115 m² that are not used for exhibition or display and are not part of mixed occupancy;
- Assembly occupancy with all sides open; and
- Places of worship at the level of exit discharge with sufficient means of egress.

No. of seats	Clear width per seat served (in mm)	
	Stairs	Passageways, Ramps, and Doorways
Unlimited	7.6 AB	5.6C

Section 13-A. Assessment of Fire Code Taxes, Fees and Fines.– **The assessment of fire code taxes, fees and fines is vested upon the BFP.** The BFP shall subject, subject to the approval of the DILG, prescribe the procedural rules for such purpose.”



The Fire Safety Inspection Fee is among the Fire Code Revenues, which the BFP is authorized to collect as prerequisite to the grants of permits and/or licenses by local government. Section 12.0.0.2 (A)(6) of the Implementing Rules and Regulations of Republic Act No. 9514 states, to wit:

“6. Fire Safety Inspection Fee. Fee charged for the conduct of Fire Safety Inspection equivalent to **ten per centum (10%) of all fees charged by the building official, or by the Local Government or by other government agencies concerned in the granting of pertinent permits or licenses**”

Based on the foregoing, all concerned government officials within their respective territorial jurisdictions in the NCR are hereby directed to abide by the pertinent provisions of Republic Act No. 9514 and its Implementing Rules and Regulations on the authority of the BFP to assess and collect the necessary Fire Safety Inspection Fees, required to be paid by the applicants prior to the issuance of their Business Permits. All collections made prior to the effectivity of this circular are hereby ordered to be turned over to the possession and custody of the City Fire Marshall concerned for proper remittance to the National Treasury under the trust fund assigned to the BFP.

The City Fire Marshalls within the NCR are hereby directed to coordinate with the concerned local government officials of their respective jurisdictions as regards the efficient and expeditious procedure for the collection of the subject fees.

Please be guided accordingly.

JESSE M. ROBREDO
 Secretary
 Republic of the Philippines
 DEPARTMENT OF THE INTERIOR
 AND LOCAL GOVERNMENT
 IN REPLYING, PLS CITE:
 SILG10-005371



Republic of the Philippines
DEPARTMENT OF THE INTERIOR AND LOCAL GOVERNMENT
BUREAU OF FIRE PROTECTION



Agham Road, Barangay Bagong Pag-Asa, Diliman, Quezon City
Tel. Number (02) 426-4399

May 18, 2011

MEMORANDUM CIRCULAR

NO: 2011-73

TO : ALL REGIONAL DIRECTORS AND PROVINCIAL,
CITY AND MUNICIPAL FIRE MARSHALS

SUBJECT : IMPLEMENTING DETAILS OF SECTION 14.0.0.7 OF
THE IRR OF RA 9514

DATE : 06 MAY 2011

I. BACKGROUND

The Implementing Rules and Regulations of RA 9514 otherwise known as the Fire Code of the Philippines, Section 14.0.07 as amended provides:

These Implementing Rules and Regulations shall take effect 30 days after publication of the last installment in a newspaper of general circulation.

Transitory Clause. The owner, administrator or occupant of buildings or structures existing at the time of the effectivity of RA 9514 and its IRR is given two (2) years to comply with the provisions on the requirements for installation of the Automatic Fire Suppression System (sprinkler system), provided, however, that the buildings or structures must be compliant to the provisions on fire safety system and requirements of PD1185 during the period of compliance.

Pursuant to the policy of the State to strengthen public safety and promoting economic development through the prevention and suppression of all kinds of destructive fires, RA 9514 is now more stringent in implementing fire safety measures and requirements. One of these requirements is the installation of automatic fire facilities such as the Automatic Fire Suppression System (AFSS) which has proven to be of great help in ensuring fire safety, preventing loss of life and of mitigating damage of property caused by fire. However, with its implementation,

Example 2: CAPACITY FACTORS FOR THEATER TYPE SEATING

An auditorium has 5000 seats. It is not smoke protected. One stair is 1780 mm wide; riser height is 190 mm; handrails are positioned at each side; there is no handrail along the center of the aisle. One ramp is 1120 mm wide and rises with a slope of 1 in 9 to the rear exit door.

Exit Details

(Section 10.2.8.2)

Location of Exits

Main exit – ½ of the total occupant load

Other exits – 2/3 of the total occupant load

Minimum Corridor Width

112 cm (serving 50 or more persons)

Protection (Section 10.2.8.8)

1. Fire Detection and Alarm System

- * All assembly occupancies – manual fire alarm system
- * More than 300 persons – through automatic detection system

2. Extinguishing Requirement

- The following assembly occupancies shall be protected through by an approved, supervised sprinkler system:
 - a. bars with live entertainment;
 - b. dance halls;
 - c. discotheques; and
 - d. assembly occupancies.
- Buildings containing assembly occupancies with occupant load of more than 300 shall protected by an approved, supervised sprinkler system:
 - a. throughout the storey containing the assembly occupancy ;
 - b. throughout all storeys below the storey containing the assembly occupancy;

- 24. conference rooms; and
- 25. mortuary chapels or funeral homes

- Restaurants and drinking establishments with an occupant load of less than 50 persons shall be classified as mercantile occupancies.
- Occupancy of any room or space for assembly purposes by less than fifty (50) persons in a building of other occupancy and incidental to such other occupancy shall be classified as part of the other occupancy and subject to the provisions applicable thereto.

Occupant Load

- Area having fixed seats – no. of fixed seats installed.
- Posting of occupant load in a conspicuous place near the main entrance/exit of the room.
- Waiting space shall not encroach upon the required clear width of exits

Exit Details

CAPACITY FACTORS FOR THEATER TYPE SEATING

* If riser exceed 178 mm:

$$A = 1 + (\text{riser height} - 178/125)$$

* If stair has no handrail within 760 mm"

$$B = 1.25$$

* If ramp is steeper than 1: 10 in slope used

upwards:

$$C = 1.10$$

Example 1: CAPACITY FACTORS FOR THEATER TYPE SEATING

An auditorium has 5000 seats. It is not smoke protected. One stair is 1780 mm wide; riser height is 178 mm; handrails are positioned at each side; an additional handrail runs along the center of the aisle. One ramp is 1120 mm wide and rises with a slope of 1 in 12 to the rear exit door.

many buildings were affected and find it difficult to comply instantaneously, hence, the amendment of Section 14.0.0.7 of the IRR of 9514 and these implementing details, giving two (2) years moratorium to affected buildings and structures.

II. SCOPE

These implementing guidelines shall apply to all buildings or structures existing at the time of the effectivity of the IRR of RA 9514 on November 18, 2009 and were compliant to the provisions of PD 1185.

These also apply to all buildings or structures that were not required AFSS installation by PD 1185 and its IRR but are now required to install AFSS due to the changes introduced by RA 9514 and its IRR.

Further, these also apply to new buildings applying for FSIC for occupancy whose Fire Safety Correction Sheets were approved prior to the effectivity of the IRR or RA 9514 on November 18, 2009. These buildings were not required to install sprinkler systems upon approval of its Fire Safety Correction Sheets, however by virtue of the provisions of RA 9514, they are required to install sprinkler system upon application of FSIC for occupancy.

III. POLICIES AND PROCEDURES

1. The two (2) year moratorium/ period of compliance shall commence on February 14, 2011.

2. Upon application of a building/structure owner or administrator for Fire Safety Inspection Certificate (FSIC), the MFM/CFM or its authorized representative, shall evaluate the documentary requirements and conduct inspection on buildings/structure to determine compliance with Presidential Decree 1185. After evaluation and inspection, the following have to be observed:

a. Should the building/structure fall within the scope embodied in Item II of this circular, then the two (2) years moratorium is applicable. The owner or administrator thereof will be required to execute an Affidavit of Undertaking, stating that they will comply with the provisions of RA 9514 on the requirements for installation of AFSS within the two-year moratorium period. After complying with the other requirements of the Fire Code, an FSIC will then be issued in accordance with the provisions of RA 9514 and its IRR.

b. Should the building/structure not fall within the scope enumerated in item II, the two-year moratorium is not applicable.

3. If the building/structure is not covered by this circular granting two-year moratorium, the owner or administrators thereof shall apply for an Alternative/Remedial Measures under Memorandum Circular No. 2010-17. The issuance of the Fire Safety Inspection Certificate (FSIC) shall be dependent on the compliance of the approved alternative/remedial measures.

IV. REPEALING CLAUSE

All directives, issuances, memoranda inconsistent with this Memorandum Circular are hereby repealed or amended accordingly

V. EFFECTIVITY

This Memorandum Circular shall take effect immediately.

ROLANDO M. BANDILLA JR., CESO IV
DIRECTOR BFP
Chief, BFP

Approved by:

JESSE M. ROBREDO
Secretary



FIRE PROTECTION FEATURES FOR DIFFERENT TYPE OF OCCUPANCIES

A. PLACES OF ASSEMBLY

Definition

Buildings or portions of buildings used for gathering together of fifty (50) or more persons for such purposes as deliberation, worship, entertainment, eating, drinking, amusement, awaiting transportation or similar uses.

Examples

1. theaters;
2. assembly halls;
3. auditorium;
4. exhibition halls;
5. museum;
6. restaurants;
7. drinking establishments;
8. places of worship;
9. classrooms of 50 persons and over capacity;
10. libraries;
11. internet shops of over 50 persons capacity;
12. dance halls;
13. club rooms;
14. skating rinks;
15. gymnasiums
16. cockpit arenas;
17. bowling facilities;
18. pool rooms;
19. armories;
20. passenger stations and terminals of air, surface, underground, and marine public transportation facilities;
21. Recreational facilities;
22. piers;
23. court-rooms;

FEATURES OF FIRE PROTECTION



Republic of the Philippines
DEPARTMENT OF THE INTERIOR AND LOCAL GOVERNMENT
BUREAU OF FIRE PROTECTION



Agham Road, Barangay Bagong Pag-Asa, Diliman, Quezon City
Tel. Number (02) 426-4399

FEB. 14, 2012
Date

MEMORANDUM CIRCULAR
NUMBER: SOP-2012-001

**SUBJECT : STANDARD OPERATING PROCEDURE (SOP)
IN THE PREPARATION AND ISSUANCE OF
INSPECTION ORDER, AFTER INSPECTION
REPORT AND LEVEL OF AUTHORITY OF CITY/
MUNICIPAL FIRE STATION, PROVINCIAL/
DISTRICT OFFICES AND REGIONAL
HEADQUARTERS IN THE CONDUCT OF FIRE
SAFETY INSPECTION**

I. Applicability

This SOP shall apply to the conduct of fire safety inspections and remedial measures to be taken by the Fire Safety Inspectors, Plan Evaluators, Chief of concerned fire safety unit/section/branch in the municipality/city, district/province, region and national levels. It governs the jurisdictional/relationships between and among the BFP organizational units and the Fire Code of the Philippines of 2008 and its Implementing Rules and Regulations (IRR). This also applies to all officers and personnel of the BFP whose duties and responsibilities pertain to the enforcement of the Code.

II. POLICIES AND PROCEDURES

A. Inspection Order (IO)

1. Issuance of IO. All fire safety inspection conducted by any BFP office and personnel duly authorized to perform inspection shall be covered by an Inspection Order (IO) issued for the specific purpose and place to be inspected. The IO should not contain any all-embracing purpose such as "valid for inspections

of any building, business, commercial or industrial establishments within area of jurisdiction”.

2. Format of IO. The IO shall be in the FORM shown in Annex “A” hereof, and no inspection shall be conducted using any other form of IO not conforming thereto.

The IO shall contain the names of Fire Safety Inspector (FSI) or Inspectors who shall conduct the inspections, and no inspection shall be performed by any personnel whose name is not indicated therein and any other unauthorized personnel be allowed to participate in the inspection.

3. Purpose of IO. Inspection Order shall be issued for the following purposes:

a. To conduct inspection during construction, renovation, modification or alteration on the basis of issued Fire Safety Clearance to determine whether the plans, and specifications are being followed and safety precautions are being observed;

b. To conduct Fire Safety Inspection required under RA 9514, known as Fire Code of the Philippines of 2008 and its Implementing Rules and Regulations prior to the issuance of Fire Safety Inspection Certificate;

c. To conduct business and routine inspection required under Section 9.0.2.4 of the IRR of RA 9514;

d. To conduct Fire Safety Inspection prior the issuance of Fire Safety Clearance required under Division 5 of Section 9.0.4.2 of the IRR of RA 9514;

e. To conduct inspection prior to the issuance of Installation Clearance required under Section 10.2.7.6 of the IRR of RA 9514;

f. To conduct re-inspection required under Section 13.0.0.4 of the IRR of RA 9514; and

g. Other inspection that may be issued by the duly authorized representative of the Chief, BFP for the purpose of the enforcement of RA 9514 and its IRR.

Ladders

- No ladder shall be used as a fire escape except in single and two family dwellings and residential apartments of not more than three (3) storey provided that the height shall not exceed nine meters (9m).
- For purposes of this subsection, mezzanine floors shall be counted as ordinary floor.

Illumination and Markings of Means of Egress

- Emergency lighting facilities shall be arranged to maintain the specified degree of illumination in the event of failure of the normal lighting for a period of at least one and one half (1½) hours.
- All emergency lighting systems installed in accordance with this section shall be properly maintained.

Protection of Vertical Openings

- Openings between storeys shall be enclosed or protected to prevent the spread of fire or smoke, except openings of building protected by automatic fire suppression system

Exemption:

- Building with low or ordinary hazard occupancy protected with approved, supervised sprinkler automatic fire suppressions system up to three (3) communicating floor levels.
 - a. The arrangement is permitted by the applicable occupancy section of this Chapter.
 - b. The lowest or next to the lowest level is a street floor;
 - c. The entire area, including all communicating floor levels, is sufficiently open and unobstructed so that it may be assumed that a fire or other dangerous condition in any part will be immediately obvious to the occupants of all communicating levels and areas;

TABLE 7. Fire Escape Stairs

PARTICULARS	DIMENSIONS
Minimum widths	60 cm clear between rails
Minimum horizontal dimension any landing of platform	60 cm
Maximum rise	23 cm
Minimum tread, exclusive of nosing	23 cm
Tread construction	Solid, 13 mm diameter perforation permitted
Winders (spiral)	None
Risers	None
Maximum height between landings	3.66 m
Headroom, minimum	2.00 m
Access to escape	Door or case-ment windows 61 cm by 1.98 m or double hung windows 76.20 cm by 91.44 cm clear
Level of access opening	Not over 30.50 cm above floor; steps if higher
Discharge to ground	Swinging stair section permitted
Capacity number of persons	45 per unit* access by door; 20 if access by climbing over window rail

4. Administrative Control on Issuance of IO. Every IO shall be chronologically numbered and recorded in an official log book. Computer based recording of IO is likewise encouraged. Entries in the log book shall contain the IO Number; the name(s) of the FSI's who will conduct the inspection; the exact address of building/establishment subject of inspection; the purpose of inspection - whether for supervisory inspection of building under construction, or final inspection of newly constructed/modified/renovated building, or initial inspection of business, commercial or industrial establishments, or verification or investigation of complain, etc; the date of issuance and actually received by the FSI's; and date it was served or cancelled, as the case maybe.

5. Service of IO and Limitation of its Issuance

a. Service of IO shall mean the conduct of actual inspection and submission of necessary report to the Chief, Fire Safety Enforcement Section (C,FSES) of the respective Province/District/City/Municipal fire station for his evaluation. In case the FSI was not allowed by the owner/occupant/administrator or his duly authorized representative to conduct inspection, the FSI shall write **"Addressee Refuses to Receive the IO and Allow Inspection"** in the remarks portion of the IO, and shall immediately return the same to the **ISSUING** office.

b. The inspector whose IO was not accepted and not allowed to conduct inspection shall be required to prepare a letter signed by the head of office (Municipal/City Fire Marshal, Provincial/District Fire Marshal or Regional Director) authorizing the inspection, notifying addressee that ten (10) days upon receipt of letter, actual inspection of subject place shall be conducted under a new IO, copy of which shall be attached to the letter. The letter together with the IO shall be sent thru registered mail and **SHALL BE CONSIDERED SERVED** upon receipt of the registered mail.

c. Actual inspection shall be conducted during the actual operation of the business establishment or any structure, facilities, and hazardous operation.

d. Issued IO shall be immediately conducted within two (2) days from its issuance. Concerned fire safety inspector shall

prepare and submit the necessary report within twenty-four (24) hours after the conduct of actual inspection. Where the period falls during non-working days, the report shall be submitted immediately on the following working day.

e. Any IO which was not served within five (5) days upon its issuance shall be accordingly cancelled and the cancellation shall be likewise recorded in the logbook.

f. Issuance of IO shall be limited only to five (5) IOs for every individual or team of fire safety inspectors in a day. However, no IO shall be issued to individual or team of fire safety inspectors who still have two (2) pending IO to be served.

g. IO shall not be issued to FSI who is actually absent from work.

6. Wearing of Proper Attire and BFP ID. All BFP personnel issued with IO shall wear their proper uniform with BFP ID during the conduct of actual inspection:

- GOA for Uniformed BFP Personnel
- Barong for Non-uniformed BFP Personnel.

B. AFTER INSPECTION REPORT (AIR)

1. Inspection during Construction. The frequency and result of fire safety inspection conducted to monitor compliance of building under construction with the approved plans shall be recorded in the Construction Logbook Sheet kept in the site by whoever is responsible for the construction. Whenever the result shows any violation or non-compliance with the approved plans, the City/Municipal Fire Marshal shall issue a written notice informing the person (responsible for the construction) of the violation noted. A copy of the notice shall also be sent to the Building Official.

2. Inspection after Construction. The procedure in the preparation and issuance of AIR after construction shall be in accordance to Section 9.0.2.3 of the IRR of RA 9514 or the Fire Code of the Philippines of 2008.

3. Periodic Inspections of Occupancy.

Smoke proof enclosures may be by any of the following means:

- Natural ventilation
- Mechanical Ventilation
- Stairway Pressurization

Ramps

TABLE 6. DIMENSIONAL CRITERIA FOR NEW RAMPS

Feature	Dimensional Criteria	
	mm	in
Minimum width clear of all obstructions, except projections not more than 4½ in. (114 mm) at or below handrail height on each side	1120	44
Maximum slope	1 in 12	
Maximum cross slope	1 in 48	
Maximum rise for a single ramp run	760	30

TABLE 4. DIMENSIONAL CRITERIA FOR EXISTING STAIRS

Feature	Dimensional Criteria	
	mm	in
Minimum width clear of all obstructions, except projections not more than 114 mm (4½ in) at or below handrail height on each side	915	36
Maximum height of risers	205	8
Minimum tread depth	230	9
Minimum headroom	2000	80
Maximum height between landings	3660	144

TABLE 5 NEW STAIR WIDTH

Total Cumulative Occupant Load Assigned to the Stair	Width	
	mm	in
<2000 persons	1120	44
≥2000 persons	1420	56

a. The result of actual inspection conducted under issued IO shall be duly recorded in the prescribed and standard form for AIR which shall be accomplished by the FSI upon conclusion of his inspection and prior leaving the premises of the place inspected.

b. The AIR shall be accomplished in three (3) copies, one for BFP, 2nd for the Building Official or Business Licensing Office, as the case maybe, and 3rd for the owner/administrator)

c. In case the AIR is refused to be signed, the FSI should write the phrase "REFUSED TO SIGN" over the portion of the AIR where the name and signature of the receiving party is indicated.

d. In case the AIR is not accepted, the FSI may leave the copy to the guard or any occupant of the place found therein with sufficient discernment or understanding, or may send it by registered mail, in cases where personal service cannot be made upon the addressee, or upon his representative or any other occupant of the place inspected.

C. Fire Safety Inspection

1. Authority of Fire Safety Inspectors. As provided under the Code, fire safety inspection shall be done by the Fire Safety Inspectors, and in places where there are no such inspectors, the Fire Marshal shall, in addition to his duties and functions, act as safety inspectors.

2. Jurisdiction of Inspection by City/Municipal Fire Stations. The City/Municipal Fire Stations shall conduct fire safety inspection thru duly designated FSI of its Fire Safety Enforcement Branch/Unit. The inspection shall be limited to the following:

a. Inspection of buildings, structures or facilities during construction, renovation or modification to determine whether the approved plans are followed and safety measures are observed in the working areas.

b. Inspection of the buildings, structures or facilities after completion of construction, renovation or modification and prior to the issuance of Occupancy Permit by the

Building Official to determine compliance with approved plans and with the working condition of the installed fire protective and/or warning system, IF ANY.

c. Inspection on all industrial, commercial or business establishment in connection with their application for permits and/or licenses with the local governments or other government agencies, and during their on-going operations.

d. Inspection on storage, handling and/or use of explosives or of combustible, flammable, toxic and other hazardous materials.

e. Inspection conducted periodically on all existing buildings, structures or facilities, including all industrial, commercial or business operations, to determine the presence of any fire hazards; the type of occupancy; the prohibited acts being committed or tolerated therein; and to check or test the required fire protective and/or warning system.

3. Jurisdiction of District/Provincial Offices. The district/provincial offices shall also conduct fire safety inspections within the areas under their jurisdiction thru duly DESIGNATED FSI of its Fire Safety Enforcement Section. Inspection shall be limited to the following:

a. Re-inspection or verification inspection of the building, structure or facility initially inspected by the city/municipal FSI when the result of which indicate no compliance with the requirements and/or where there is deficiency in its compliance, as indicated in the AIR submitted to the District/Provincial Offices

b. Inspection of buildings, structures or facilities and industrial, commercial or business establishment's subject of any complaints, where the act or omission being complained of pertains to the inspections conducted by the city/municipal FSI's.

4. Jurisdiction of BFP Regional Headquarters. The Regional Headquarters may constitute a composite team or "Task Force", which may be composed of personnel from their Operations Divi-

Doors

* min width - 71 cm clear width

* max width - 122 cm

* provision for re-entry mechanism for four (4) or more storeys in height (every 4 storey)

NO RE - ENTRY

PROCEED TO _____ FLOOR

AND _____ FLOOR

Stairs

TABLE 3. DIMENSIONAL CRITERIA FOR NEW STAIRS

Feature	Dimensional Criteria	
	mm	in
Minimum Width	See Table for New Stair Width	
Maximum height of risers	180	7
Minimum height of risers	100	4
Minimum tread depth	280	11
Minimum headroom	2000	80
Maximum height between landings	3660	144

☛ The travel distance is measured as follows:

1. Starting at the most remote point subject to occupancy
2. On the floor or other walking surface
3. Along the centerline of the natural path of travel
4. Around corners and obstruction with a clearance of 0.3 m (1 ft)
5. Over open exit access ramps and open exit access stairs in the plane of tread nosing
6. Ending where the exit begins

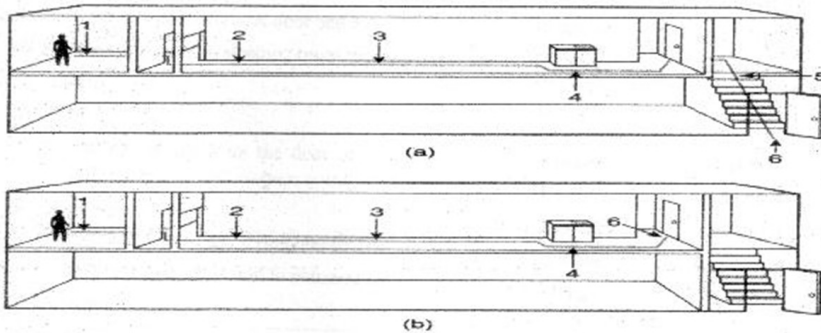

Illustration 2. Travel Distance

Headroom

- Minimum headroom shall not be less than 2 meters.

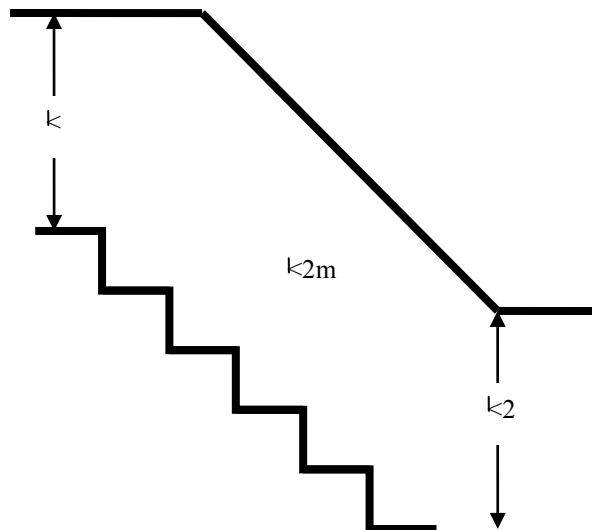

Illustration 3. Headroom

sion, Fire Safety Enforcement Section and Fire Safety Inspectors from district/provincial offices and city/municipal fire stations, inspection shall be limited to the following cases;

a. Processing of requests for alternative and/or remedial fire safety measures endorsed by the District/Provincial Offices prior endorsement to BFP-National Headquarters;

b. Re-inspection of actual conditions in buildings, structures or facilities, industrial, commercial or business establishments on controversies appealed/elevated by the owner/administrator to Region.

c. Re-inspection/verification of the fire safety inspection of buildings, structures, or facilities inspected by the FSI's of district/provincial offices but did not comply with the fire safety requirements or when there is deficiency with the compliance;

d. In cases of an aftermath of natural or man-made disaster where fire safety and life safety situations in buildings, structures or facilities are adversely affected; and

e. To cover areas where there is a failure in the enforcement of the Fire Code.

5. Jurisdiction of BFP National Headquarters. The BFP National Headquarters thru the Directorate for Fire Safety and Prevention **MAY** conduct inspection on all buildings, structures and facilities and in any industrial, commercial or business establishments in any city, municipality, province or region, limited to the following cases:

a. Evaluation of basis of recommendations for the summary abatement of fire hazards involving alteration, renovation or modification of buildings, structures or facilities, or its closure or demolition declared as public nuisance;

b. Re-inspection/verification of the fire safety inspection of buildings, structures, or facilities inspected by the composite team or task force of the Regional Offices.

c. Random Validation of the administrative action taken

in the field offices to determine if the procedure has been properly observed

III. EFFECTIVITY

This SOP shall take effect immediately upon approval.



SAMUEL R PEREZ, CEO VI
CSUPT (DSC) BFP
Officer-in-Charge/
Deputy Chief for Administration

Illustration 1. Arrangement of Means Egress

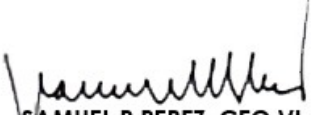
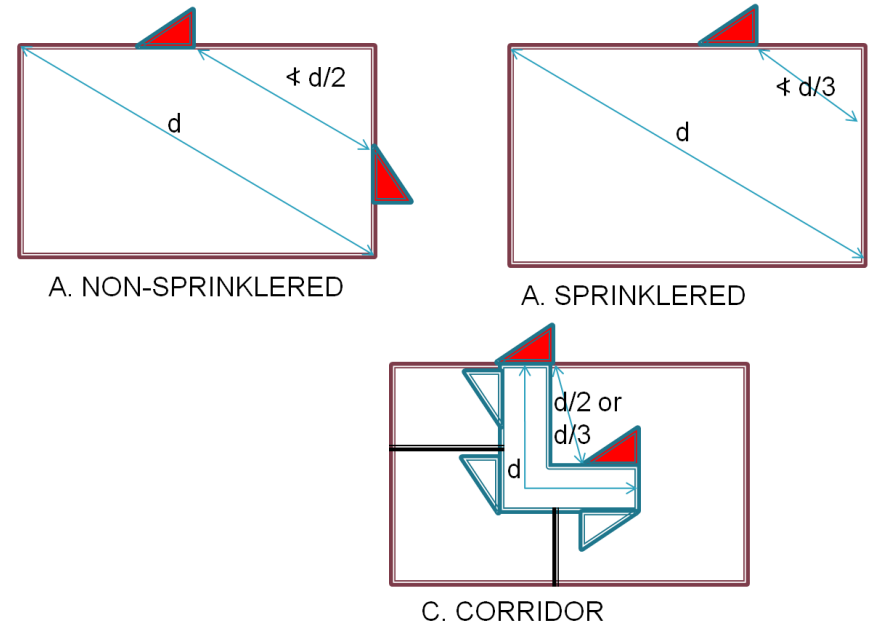

Travel Distance

- 46 m – no sprinkler
- 61 m – with sprinkler
 - * unless modified by individual occupancies
 - * along the walking surface
 - * starting from the most remote point
 - * giving 30 cm clearance from the corner
 - * ending at the center of the doorway or other point at which the exit begins

Division 8 through 17 of the IRR of RA 9514.

- B. When the occupant load for any storey or portion thereof is more than **five hundred (500)** but not more than **one thousand (1000)**, the means of egress shall **not be less than three (3)**; in excess thereof, the means of egress shall not be less than four (4).

Arrangement of Means of Egress

- provide access for each occupant to not less than two exits by separate ways of travel.
- provide exit access without passing through any intervening rooms.
- Interlocking or scissor stairs shall be considered only as a single exit for new buildings.
- Shall be remote from each other as possible, determined as follows

A. No Sprinkler:

One-half (1/2) of the length of the maximum overall diagonal dimension of the building or area to be served, measured in a straight line between the nearest edge of the exit doors or exit access doors.

B. With sprinkler

The minimum separation distance between two exits or exit access doors shall not be less than one-third (1/3) the length of the maximum overall diagonal dimension of the building or area to be served.

C. Where exit enclosures are provided and are interconnected by not less than 1-hour fire resistance-rated corridor, exit separation shall be measured along the line of travel within the corridor.



Republic of the Philippines
Department of the Interior and Local Government
BUREAU OF FIRE PROTECTION
NATIONAL HEADQUARTERS
Agham Road, Brgy. Bagong Pag-asa, Quezon City



MEMORANDUM

TO : All Regional Directors

SUBJECT : CLARIFICATION RE. SELECTION OF FIRE EXTINGUISHER FOR ENCLOSED/ AIRCONDITIONED OFFICES

DATE : May 7, 2012

This pertains to the issue raised by GAY A TIDALGO, Officer-in-Charge, Department of Trade and Industry, Agusan Del Norte regarding the alleged requirement on the usage of HCFC 123 chemical for fire extinguisher instead of monoammonium phosphate (MAP) for enclosed/ air-conditioned offices.

Let it be clarified that the Fire Code of the Philippines does not provide specific type of fire extinguisher to be installed in enclosed/ air-conditioner offices. As general requirement, fire extinguisher shall be determined by the character of the fires anticipated, the construction and occupancy of the individual property, the hazard to be protected, ambient-temperature conditions, and other factors. Fire extinguisher shall be selected depending on the classes of hazards to be protected. If a building or room poses Class A, B,C & D hazards, such building shall be provided with fire extinguishers capable of suppressing the same fire potentials as might be present. MAP and other dry chemical fire extinguishers are for use on Class A-B-C fires and/or Class B-C fires. Hence, they may be allowed in an enclosed/ air-conditioned office as long as they are capable of suppressing the fire hazards therein. Provided that for the protection of delicate electronic equipment (which may be found in computer rooms/shops), the following provisions of the Fire Code shall apply:

Section 10.2.6.7.F.3.C of the Implementing Rules Regula-

tions (IRR) of RA 9514

“3. Application for Specific Hazards
XXX

C. Fire Extinguishers for the protection of delicate electronic equipment shall be selected from either a carbon dioxide type or a halogenated agent type.”

However, due to their ozone depleting potential, halogenated extinguishing agent are included in the DENR Administrative Order No. 2008-04, List of Controlled Substances of the Montreal Protocol. Corollary hereof, clean agent extinguishers are used as their replacement. These clean agents include hydrochlorofluorocarbon (HCCF), hydrofluorocarbon (HFC), perfluorocarbon (PFC), or fluoriodiocarbon (FIC). HCFC 123 though may still be used to substitute halon-containing fire extinguishers, suppressors and fire fighting paraphernalia until its phase out in 2040.

Henceforth, all Regional Directors are directed to ensure that the provisions in the selection, application and distribution of fire extinguisher as stipulated in Section 10.2.6.7 of the Implementing Rules and Regulations of the Fire Code of the Philippines are observed by their respective City/Municipal Fire Marshals.

For strict compliance.

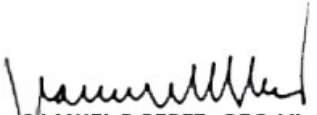

SAMUEL R PEREZ, CEO VI
CSUPT (DSC) BFP
Officer-in-Charge/
Deputy Chief for Administration

TYPE OF OCCUPANCY	OCCUPANT LOAD FACTOR (square meters per person)
4. Detention and Correctional	11.1
5. Residential	18.6
6. Mercantile a. Street floor b. Upper floors	 2.8 5.6
7. Business	9.3
8. Industrial	9.3
9. Storage	Maximum probable population

Minimum Width

It shall not be less than **nine hundred fifteen millimeters (915 mm)** except when specifically provided under Division 8 to Division 17 of the Implementing Rules and Regulations of RA 9514.

Number of Means of Egress

A. The number of means of egress from any balcony, mezzanine, storey, or portion thereof shall not be less than two (2), except when specifically permitted in

the floor area by the occupant load factor assigned to that use.

$$= \frac{\text{Gross Floor Area}}{\text{Occupant Load Factor}}$$

Table 2. Occupant Load Factor

TYPE OF OCCUPANCY	OCCUPANT LOAD FACTOR (square meters per person)
1. Assembly	
a. concentrated use without fixed seats	0.65
b. less concentrated use	1.4
c. standing room or waiting space	0.28
2. Educational	
a.net classroom area	1.9
b.net area of shops, laboratories and similar vocational rooms	4.6
3. Health Care	
a. sleeping departments	11.1
b. inpatient treatment departments	22.3



Republic of the Philippines
 Department of the Interior and Local Government
BUREAU OF FIRE PROTECTION
NATIONAL HEADQUARTERS
 Agham Road, Brgy. Bagong Pag-asa, Quezon City



MEMORANDUM

TO : All Regional Directors, Provincial, District, City/Municipal Fire Marshals and All Concerned

SUBJECT : Proper Interpretation of Section 10.5.3.5 para. F of the IRR of RA 9514 otherwise known as the Fire Code of the Philippines of 2008 re: Fire Extinguisher prohibited for manufacture or sale containing Ozone Depleting Substances (ODS)

DATE : 05 October 2011

Section 10.5.3.5 para. F of the IRR of RA 9514, otherwise known as the Fire Code of 2008, provides that the fire extinguishers containing Ozone Depleting Substances (ODS) are prohibited for manufacture or sale. Plain reading of the said section implies that all fire extinguisher, as long as it contains ODS, can no longer be used in any occupancy as basis for compliance the required fire protection appliance under the Fire Code.

Thus, some fire safety inspectors in the field offices, no longer recommend the use of fire extinguishers containing ODS, and allegedly advised some of our clients to replace those who have existing fire extinguishers found to have ODS.

As a consequence thereof, there are manufacturers, dealers or suppliers that lodge a clarification and complaint before the SILG and this office, concerning the effect of the aforesaid provision of the IRR of RA 9514, which totally prohibit the manufacture and use of fire extinguishers containing ODS. One of the fire extinguishers they cited is HCFC 123, where some of our BFP personnel in the field offices informed their clients that it is already prohibited under the Fire Code.

On the other hand, prior to the effectivity of RA 9514, the Department of the Environment and Natural Resources (DENR) issued a DENR Administrative Order No. 2004-08 concerning the regulation of the importation, exportation, use, manufacture, distribution, processing, storage, possession and sale, as well as the ban on importation and phasing-out schedule and controls of ODS, which reads in part:

“Section 4. BAN ON IMPORTATION OF ODS

The ban on importation, except for essential uses, in any amount, of the following substances whether alone or in mixtures as previously enunciated in the Notice to the Public dated December 1998 is hereby affirmed:

a. Annex A Group I

- CFC 11 and CFC 12 banned for importation for manufacturing products and equipment since 01 January 1998.
- CFC 113 since 01 January 1996
- CFC 114 and CFC 115, except as component in R-502, since 01 January 1998.

b. Annex A Group II since 01 January 1999

c. Annex B Group I since 01 January 1999

d. Annex B Group II since 01 January 1996

e. Annex B Group III since 01 January 1996

Section 5. PHASE-OUT SCHEDULE AND CONTROLS OF IMPORTATION OF ODS

5.1 The Department through the Bureau will allow importation of Annex A, Group I & II, Annex B Group I, II & III for:

a. Essential uses as defined by the Montreal Protocol, as amended; and

b. For the servicing requirements of existing equipment.

5.2 Consistent with Section 4 and Section 5.1 hereof, an import quota allocation system shall be implemented by the Department through the Bureau. For this purpose, individual annual import quota per substance under Annex A, Group I specifically CFC-11,

Protective Enclosures

- * three storeys or less – one (1) hour
- * four or more storeys – two (2) hours
- * any opening shall be protected by an approved self-closing fire resistive door
- * no exit enclosure shall be used for other purposes

Table 1. Capacity of Means of Egress

Area	Stairways (width per person)		Level Components and Ramps (width per person)	
	mm	in	mm	in
Board and Care	10	0.4	5	0.2
Health Care, Sprinklered	7.6	0.3	5	0.2
Health Care, Non-Sprinklered	15	0.6	13	0.5
High Hazards	18	0.7	10	0.4
All Others	7.6	0.3	5	0.2

Occupant Load

Shall be the maximum number of persons that may be in space at any time, as determined by the City/Municipal Fire Marshal but shall not be less than the number computed by diving

MEANS OF EGRESS

Means of Egress - A continuous and unobstructed way of travel from any point in a building or structure to a public way consisting of three separate and distinct parts: (1) the exit access, (2) the exit, and (3) the exit discharge.

1. **Exit Access.** That portion of a means of egress that leads to an exit.

2. **Exit.** That portion of a means of egress that is separated from all other spaces of a building or structure by construction or equipment as required to provide a protected way of travel to the exit discharge.

3. **Exit Discharge.** That portion of a means of egress between the termination of an exit and a public way

COMPONENTS OF MEANS OF EGRESS:

- Doors
- Stairs and outside stairs
- Horizontal exits
- Ramps
- Exit passageway
- Escalators
- Fire Escape Stairs, Ladders and slide escapes
- Illumination of means of egress
- Exit markings

CFC-12 and CFC-115 in R-502 shall be determined by the Department through the Bureau.

5.3 In case of mixtures or blends containing any of the substances under Annex A, Group I specifically CFC-12 and CFC-12 and CFC-115, the calculation of import quota shall be based on the percent content by weight of these substances.

5.4 The annual import quota is non-cumulative, thus, any remainder of the quota Allocation for a particular substance is deemed consumed at the end of the calendar year. The total annual imports shall be within the phase-out schedule below:

For Annex A, Group 1 (specifically CFC-11, CFC-12 and CFC-115 in R502):

a. Starting 01 January 1999, imports shall not exceed the recorded average of the annual importation for the period 1995-1997 by ODP weight;

b. Starting 01 January 2005, imports shall have been reduced by fifty percent (50%) based on the recorded average of the annual importation for the period 1995 1997 by ODP weight.

c. Starting 01 January 2007, imports shall have been reduced by eighty five percent (85%) based on the recorded average of the annual importation for the period 1995-1997 by ODP weight.

d. Starting 01 January 2010, all importation will be prohibited.

For Annex C:

a. Starting 01 January 2016, imports shall not exceed the recorded annual importation for year 2015 by ODP weight.

b. Starting 01 January 2040, importation shall have been absolutely prohibited.

5.5 Beginning 01 January 2005, all importation for CFC-11 will be

absolutely prohibited.

- 5.6 Beginning 01 January 2010, all kinds of importation of substances, except Essential use (alone or in mixture) under Annex A, Group I as provided under Section 5.2 will be prohibited.
- 5.7 The Department, through the Bureau, may accelerate the phase out schedules for Servicing as may be deemed necessary through the issuance of an appropriate policy instrument.

... xxx." (Underscores supplied)

(DENR Administrative Order No. 2008-04 and pertinent annexes of List of Controlled Substances of the Montreal Protocol is hereto attached as an integral part hereof.)

Well settled in statutory construction that amendment by implication is neither presumed nor favored. On the contrary, every statute should be harmonized with other laws on the same subject, in the absence of a clear inconsistency between them. [People v. Olarte, 108 Phil. 756, (1960)]

In view thereof, since the DENR is the appropriate government agency which regulates the importation, exportation, use, manufacture, distribution, processing, storage, possession and sale of ODS, and in order to harmonize and reconcile the provisions of the IRR of RA9514 with other laws and regulations, **the provision of Section 10.5.3.5 para. F of the IRR of RA 9514, which prohibits the manufacture or use of fire extinguishers containing ODS, shall be read and interpreted in accordance with the phasing out schedule and controls of importation of ODS set forth in the DENR Administrative Order No. 2004-08.**

Wherefore, concerned BFP personnel in the field offices are advised to strictly observe the phasing-out schedule set forth in DENR Administrative Order No. 2004-08, and shall refrain from advising our clients or from not allowing the use of fire extinguishers containing substances listed under Annex C (including HCFC 123), since the start of absolute ban for importation of these substances is scheduled on January 01, 2040, unless otherwise the DENR accelerated the phasing-out schedule.

MEANS OF EGRESS

Distribution of Fire Extinguishers

- Portable fire extinguishers are most effectively utilized when they are readily available in sufficient number and with adequate extinguishing capacity for use by persons familiar with their operation.
- In fire emergencies where fire extinguishers are relied upon, someone usually has to travel from the fire in order to obtain the device, and then return to the fire before beginning extinguishing operations. This takes time, with the number of seconds or minutes governed mainly by the travel distance involved in securing the fire extinguisher and placing it in operation.
- Sometimes fire extinguishers are purposely kept nearby (as in welding operations); however, since a fire outbreak usually cannot be prejudged as to location, fire extinguishers are more often strategically positioned throughout areas.
- Travel distance is not merely a simple circle radius matter, but is the actual distance the user of the fire extinguisher will need to walk. Consequently, travel distance will be affected by partitions, location of doorways, aisles, piles of stored materials, machinery, and so forth.

For your information and widest dissemination.



SAMUEL R PEREZ, CEO VI
CSUPT (DSC) BFP
Officer-in-Charge/
Deputy Chief for Administration



Republic of the Philippines
 Department of the Interior and Local Government
BUREAU OF FIRE PROTECTION
NATIONAL HEADQUARTERS
 Agham Road, Brgy. Bagong Pag-asa, Quezon City



MEMORANDUM

TO : CSUPT NIMFA D CUARTEL
Regional Director, R- 4A

SUBJECT : Request for Exemption from Payment of Fire Code Construction Tax

DATE : 05 October 2011

This pertains to your letter dated 27 September 2011 requesting a definitive direction on the request of the National Housing Authority (NHA) in view or in relation to the recent issuance as contained in a Memorandum signed by Chief, BFP dated 07 June 2011, re: Assessment and Collection of Fire Code Tax/Fee on All Government Sponsored Projects, and that of Section 12.0.0.2 Fire Code Revenues and Section 12.0.0.04 Schedule of Fees and Fines more particularly para C and para D.

Likewise, per your letter, Linear Construction Corporation, which was subcontracted by the NHA for the construction of one (1) - unit 3 storey (15 classrooms) school building In Sta. Rosa, Laguna, categorized as socialized housing project by the National Housing Authority, is asking exemption from payment of Fire Code Construction Tax by invoking Section 19 of RA 7279.

Scrutiny of Section 19 of RA 7279, the exemption specifically refers only to the NHA per se, which is exempted from the payment of all fees and charges of any kind, whether local or national, such as Income and real taxes. However, in so far as private sector is concerned, participating in socialized housing, the applicable provision is Section 20 of RA 7279, which partly provides:

"(d) Exemption from the payment of the following:

Example 1.

$$\frac{10,000 \text{ sq. m.}}{200 \text{ sq. m}} = 50 \text{ 2-A extinguisher for low hazard}$$

$$\frac{10,000 \text{ sq. m}}{100 \text{ sq. m}} = 100 \text{ 3-A extinguisher for moderate hazard}$$

$$\frac{10,000 \text{ sq. m}}{75 \text{ sq. m}} = 134 \text{ 4-A extinguisher for high hazard}$$

6. Fire extinguishers could be mounted on exterior walls or, as shown in Figure 2, on building columns or interior walls, and conform to both distribution and travel distance rules.

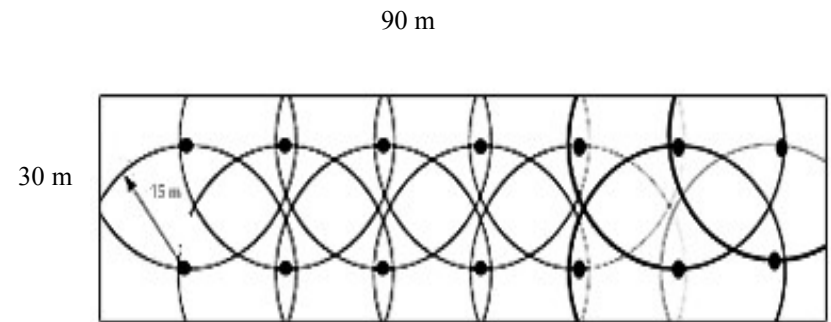

FIGURE 2. Configuration Representing 14 Fire Extinguishers Mounted on Building Columns or Interior Walls, in Which Requirements for Both Travel Distance and Fire Extinguisher Distribution are Met.

to the nearest fire extinguisher shall not exceed 15 m for ordinary hazard. It is necessary to select fire extinguishers that fulfill both the distribution and travel distance requirements for a particular occupancy classification.

3. If a building floor area were unobstructed and circular in shape with a radius of 15 m. it would be possible to place one fire extinguisher at the center without exceeding the 15 m travel distance. In that case, an area of 353.25 sq. m. However, as Table 1 requires for a maximum area of 200 square meter per fire extinguisher of 2A rating for low or ordinary hazard, the building should be equipped with at least two (2) 2A rating fire extinguisher.

4. This placement, along outside walls, would not be acceptable because the travel distance rule is clearly violated. In Figure 1, relocation or additional fire extinguishers, or both, are needed. The shaded areas indicate "voids" that are farther than 15 meters to the nearest extinguisher. The dots represent extinguishers.

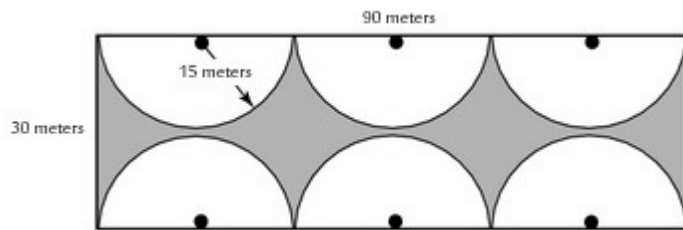

FIGURE 1. A Diagrammatic Representation of Extinguishers Located Along the Outside Walls of a 90 m × 30 m .

5. Example 1 is for fire extinguishers having ratings that correspond to protection areas of 10,000 square meters with the minimum ratings permitted by Table 1 with corresponding minimum protection areas. As the number of lower-rated extinguishers increases, meeting the travel distance requirement generally becomes less of a problem.

- (1) Project-related income taxes;
- (2) Capital gains tax on raw lands used for the project;
- (3) Value-added tax for the project contractor concerned;
- (4) Transfer tax for both raw and completed projects; and
- (5) Donor's tax for lands certified by the local government units to have been donated for socialized housing purpose."

Since the afore-quoted provision specifically mentions only those five classes of taxes, the same cannot be expanded to include fire code taxes.

Well settled in the principle governing tax is exemption is that, "Exemption from taxation are highly disfavored in law, and he who claims an exemption must be able to justify his claim by the clearest grant of organic or statute law. An exemption from the common burden cannot be permitted to exist upon vague implications (Asiatic Petroleum CO. [P.I.], Ltd. V. Llanes, 49 Phil. 466 cited in Collector of Internal Revenue V. Manila Jockey Club, Inc., 98 Phil 670; Davao Light & Power Co., Inc, v. Commissioner of Customs, et al., L-28739 &L-28902, March 29, 1972)."

To reiterate, the fourth paragraph of Memorandum dated 07 June 2011, re: Assessment and Collection of Fire Code Tax/Fee on All Government Sponsored Projects signed by the Chief, states that, "...the BFP cannot grant request for exemption / waiver in assessing and collecting Fire Code Fees for government sponsored projects, as it is not expressly provided for under RA 9514, thus, it is beyond the authority of the BFP to grant the same."

Be informed further, that recently, the Chief, BFP, in his letter reply dated 14 September 2011 to FELICISIMO F. LAZARTE, JR., Group Manager, Northern & Central Luzon Mngt. Office, denied the latter's request from payment of fees charged for the issuance of certificates, permits and licenses, in the absence of clear, categorical and express provision of the Fire Code which authorizes the Chief, BFP to grant the same.

In view thereof, in resolving the issue, please be guided by the above discussions and the two issuances by the Chief, BFP, dated 07 June 2011 and letter reply dated 14 September 2011.

For information and guidance.

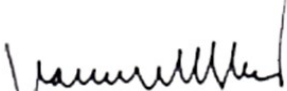

SAMUEL R PEREZ, CEO VI
CSUPT (DSC) BFP
Officer-in-Charge/
Deputy Chief for Administration

Referring to Table 1, there should be One (1) 4-A rating fire extinguisher for every 200 sq.m. Although, it would appear that 1 fire extinguisher will suffice. However, it should also comply with travel distance of 15 m. Therefore, to fulfill the area and travel distance requirements, two (2), 2-A rating for ordinary combustible materials should be provided.

Arrangement in a Building.

The actual placement of fire extinguishers can best be accomplished through a physical survey of the area to be protected. In general, selected locations should have the following characteristics:

- (1) Provide uniform distribution
- (2) Provide easy accessibility
- (3) Be relatively free from blocking by storage and equipment, or both
- (4) Be near normal paths of travel
- (5) Be near entrance and exit doors
- (6) Be free from the potential of physical damage
- (7) Be readily visible
- (8) Be installed on a floor-by-floor basis

Class A Fire Extinguisher Distribution

1. Table 1 is a guideline for determining the minimum number and rating of fire extinguishers for Class A fire protection needs in accordance with the occupancy hazard. In certain instances, through a fire protection analysis of specific areas, process hazards, or building configurations, fire extinguishers with higher ratings can be required. This does not mean, however, that the recommended maximum travel distances can be exceeded.

2. Where the floor area of a building is less than 200 sq. meter, at least one fire extinguisher of the minimum size recommended should be provided. The first step in calculating Class A fire extinguisher needs is to determine the proper class of occupancy (light, ordinary, or extra hazard). Depending on the rating of the fire extinguisher (1-A to 40-A), the maximum area that it will protect can be determined. The requirements in Table 1 also specify that the travel distance (actual walking distance) from any point

Table 1. FIRE EXTINGUISHER FOR DIFFERENT TYPES OF CLASS A HAZARDS

	LOW HAZARD	MODERATE HAZARD	HIGH HAZARD
MIN. EXTINGUISHER RATING	2-A	3-A*	4-A*
MAXIMUM TRAVEL DISTANCE TO EXTINGUISHER (m)	15	12	10
MAXIMUM AREA PER EXTINGUISHER (m ²)	200	100	75

1. Table 1 is a guideline for determining the minimum number and rating of fire extinguishers for Class A fire protection needs in accordance with the occupancy hazard. In certain instances, through a fire protection analysis of specific areas, process hazards, or building configurations, fire extinguishers with higher ratings can be required. This does not mean, however, that the recommended maximum travel distances can be exceeded.

2. Where the floor area of a building is less than 200 square meter, at least one fire extinguisher of the minimum size recommended should be provided.

Example 1: Compute the number of fire extinguishers of an office having a dimension of 5 meters by 40 meters.

Referring to (Classification of Hazard), office is classified as low hazard.

$$\text{Area} = 40\text{m} \times 5\text{m} = 200 \text{ sq. m.}$$

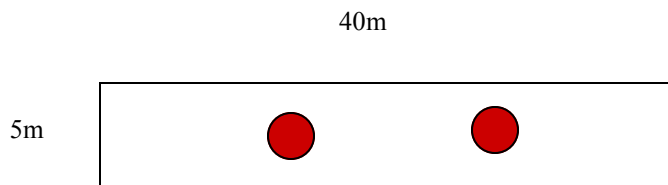

Republic of the Philippines
 Department of the Interior and Local Government
BUREAU OF FIRE PROTECTION
NATIONAL HEADQUARTERS
 Agham Road, Brgy. Bagong Pag-asa, Quezon City



MEMORANDUM

TO : ALL REGIONAL DIRECTORS

SUBJECT : ISSUANCE OF CONVEYANCE CLEARANCE

DATE : 16 September 2012

The Bureau of Fire Protection (BFP) has been receiving issues and concerns pertaining to clients who are engaged in handling and transporting of petroleum products from one place to another. Purportedly, clients who already acquired Conveyance Clearance from a certain BFP local station were required to pay for another set of Conveyance Clearance Fees by the station that has jurisdiction on the area of destination of intended delivery.

During the Management Committee (MANCOM) Meeting held last July 4, 2012, the body agreed that Conveyance Clearance issued by Fire Marshals having operational jurisdiction thereat be considered valid and effective nationwide, in the absence of any violation specified by existing laws and policies.

In view hereof, you are directed to advise all City/ Municipal Fire Marshals, within your respective areas of responsibility, to acknowledge and accept Conveyance Clearances issued to clients by a local BFP station, where said clearance was originally applied. They are not, however, barred from conducting verification and inspection on the actual condition of the flammable, combustible and hazardous materials being transported, in accordance to the packaging and other safety standard requirements set forth by the Fire Code of the Philippines (RA 9514) and other pertinent laws on fire safety. Should violations be found, the City/Municipal Fire Marshal must notify the Issuing Officer of such and recommend for the outright cancellation or revocation of the subject clearance. Failure to comply with this

directive shall be dealt with accordingly.

For guidance and strict compliance.

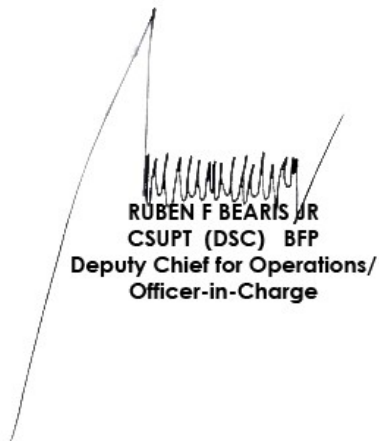

RUBEN F BEARIS JR
CSUPT (DSC) BFP
**Deputy Chief for Operations/
Officer-in-Charge**

Fire extinguishers shall be selected for the Classes of hazards to be protected..

A. Class A Hazards

- Water Type
- Multipurpose dry chemical
- Wet chemical type

B. Class B hazards

- Aqueous Film-forming foam (AFFF)
- Film-forming fluoroprotein foam (FFFP)
- Carbon dioxide
- Dry Chemical type

C. Fire extinguishers for protection of Class C hazard shall be selected from types that are specifically listed for use on Class C hazards.

D. Fire extinguishers and extinguishing agents for the protection of Class D Hazards shall be of types approved for use on the specific combustible-metal hazard.

fire extinguishers suitable for such Class A, B,C,D, fire potentials as might be present.

- D. Fire extinguishers provided for building protection can be considered also for the protection of occupancies having a Class A fire potential.
- E. Buildings having an occupancy hazard subject to Class B or Class C fires, or both, shall have a standard complement of Class A fire extinguishers of building protection, plus additional Class B or Class A fire extinguishers, or both.
- F. Rooms or areas shall be classified generally as light (low) hazard, ordinary (moderate) hazard, or extra (high) hazard. Limited areas of greater or lesser hazard shall be protected as required.
- G. On each floor level, the area protected and the travel distances shall be based on fire extinguisher installed.

- parking garages
- workshops or support service areas of low hazard occupancies
- warehouses containing Class I or Class II commodities as defined by NFPA 231, Standard for General Storage.

3. High Hazard. Extra hazard occupancies are locations where the total amount of Class A combustibles and Class B Flammables present, in storage, production use, finished product, or combination thereof, is over and above those expected in occupancies classed as ordinary (moderate)hazard. These include the following:

- woodworking
- vehicle repair
- aircraft and boat servicing
- cooking areas
- showrooms
- convention center displays
- storage and manufacturing processes

GENERAL REQUIREMENTS

SELECTION OF FIRE EXTINGUISHER

Selection of fire extinguisher for a given situation shall be determined by the following, to wit:

1. Character of fires anticipated
2. Construction and occupancy of the individual property
3. Hazard to be protected
4. Ambient-temperature conditions

DISTRIBUTION OF FIRE EXTINGUISHERS

1. General Requirements

- A. Fire extinguishers shall be provided for the protection of both the building structure and the occupancy
- B. Required building protection shall be provided by fire extinguishers suitable for Class A fires.
- C. Occupancy hazard protection shall be provided by



Republic of the Philippines
 Department of the Interior and Local Government
BUREAU OF FIRE PROTECTION
NATIONAL HEADQUARTERS
 Agham Road, Brgy. Bagong Pag-asa, Quezon City



MEMORANDUM

TO : ALL REGIONAL DIRECTORS

SUBJECT : INTESIFIED FIRE SAFETY INSPECTION OF ALL BUSINESS ESTABLISHMENT SELLING/RETAILING PETROLEUM PRODUCTS/FLAMMABLE LIQUIDS USING "PORTABLE CONTAINER"

DATE : October 15, 2012

One of the issues and concerns raised during the 1st Semester Command Conference held on September, 2012 is the absence of clear cut policy of the Bureau of Fire Protection (BFP) in dealing with business establishments involved in the retailing of petroleum products.

Be informed that under Section 7 of RA 9514, the Chief, BFP or his duly authorized representatives is mandated to ensure that safety measures are observed in the manufacture, storage, handling and /use of hazardous materials involving flammable and combustible liquids or gases of any classification through conduct of inspection.

Relative thereto, you are hereby ordered to strictly enforce RA 9514 and its Implementing Rules and Regulations (IRR) on the matter of fire safety inspection and issuance of the Fire Safety Inspection Certificate (FSIC) and other clearances to all establishments involved in the retailing of Petroleum Products.

Henceforth, the following guidelines must be observed in the course of fire safety inspection by the respective fire marshals of establishments selling or retailing petroleum products/ flammable liquids within their areas of jurisdiction:

1. Selling and retailing of petroleum products using “portable container” is not prohibited under the fire code of the Philippines provided that Section 10.3.4.2.1, IRR of RA 9514 specifically on storage and handling is observed.

“Flammable and combustible liquid shall be stored on approved containers or tanks properly labeled with physical properties of its content, flammability or combustibility and precautionary measures.”

2. For mercantile and industrial occupancies where rooms or areas are accessible to the public, storage shall be limited to quantities needed for display and normal merchandising purposes which shall not exceed eighty one liters (81liters) per square meter of gross floor area
3. No FSIC shall be issued to establishment involved in the retailing of petroleum products without full compliance to the provisions of RA 9514 and Its IRR especially to the provision on storage and handling of flammable and combustible materials.
4. In case a violation is found during the conduct of inspection, the City/Municipal Fire Marshal shall immediately issue Notice to Comply/Notice Correct Violation to erring establishment or cause the non-issuance or cancellation/revocation of Business Permit when applicable.
5. The Municipal/City Fire Marshal shall immediately issue order to pay fine to owner/administrator of establishment which fails to provide safety measures on flammable and combustible liquids in accordance to para. B.1-D of Section 12.0.0.4 of the IRR of RA 9514.
6. The Municipal/City Marshal may also seek assistance from the Philippine National Police to confiscate petroleum products/ hazardous materials stored in an inappropriate/ not approved container of a recalcitrant establishment. Confiscated petroleum products/

FIRE CODE PROVISIONS ON PORTABLE AND WHEELED FIRE EXTINGUISHERS

- The City/Municipal Fire Marshal having jurisdiction shall designate the type and number of fire extinguishers to be installed and maintained in all buildings, structures, facilities, but not be less than the minimum requirements.
- All buildings, structures and facilities shall be installed with portable fire extinguishers that are designed, installed and maintained in accordance with Section 10.2.6.7 of the Implementing Rules and Regulations of RA 9514. Fire extinguishers shall be installed even if the property is equipped with automatic sprinklers, stand-pipe and hose, or other fixed protection equipment.

CLASSIFICATION OF HAZARDS

1. **Low Hazard.** Light hazard occupancies are locations where the total amount of Class A combustible materials, including furnishings, decorations, and contents is of minor quantity. This classification anticipates that majority of content items are either noncombustible or so arranged that a fire is not likely to spread rapidly. This includes the following:
 - Offices
 - classrooms
 - churches
 - assembly halls
 - guest room areas of hotels/motels
2. **Moderate Hazard.** Ordinary hazard occupancies are locations where the total amount of Class A combustibles and Class B flammables are present in greater amount than expected under light (low) hazard occupancies. These include the following:
 - dining areas
 - mercantile shops and allied storage
 - light manufacturing
 - research operations
 - auto showrooms

RELEVANT REGULATIONS ON FIRE EXTINGUISHER

hazardous materials shall only be returned to owners of the establishment until fire safety requirements are complied.



RUBEN F BEARIS JR
CSUPT (DSC) BFP
**Deputy Chief for Operations/
Officer-in-Charge**



MEMORANDUM

TO : ALL REGIONAL DIRECTORS

**SUBJECT : ISSUANCE CERTIFICATE OF COMPETENCY (COC)
 TO MEMBERS OF COMPANY FIRE BRIGADE AS
 REQUIREMENT FOR ISSUANCE OF FIRE SAFETY
 INSPECTION CERTIFICATE (FSIC)**

DATE : October 15, 2012

This pertains to the issue on the issuance of Certificate of Competency (COC) for members of fire brigade as additional requirement for the grant of Fire Safety Inspection Certificate (FSIC) to business establishment where organization of fire brigade is required. The said issue was raised during the 1st Semester Command Conference on September, 2012.

Be reminded that under Section 6.0.2.1, Rule 6 of the Implementing Rules and Regulations (IRR) of RA 9514 states that,

“Section 6.0.2.1 Requirements

A. All business establishments employing at least fifty (50) persons shall, in addition for the requirements set forth under Section 7 of RA 9514 for the grant of Fire Safety Inspection Certificate (FSIC), establish an organization of fire brigade to deal with fire and other related emergencies...”

Further, the IRR of RA 9514 defines fire brigade as group of firefighters, primarily performing fire suppression activities in areas such as, but not limited to, community/barangay, company, and

- within a building approved for such use.
 - b. At other approved locations not less than fifteen meter (15 m) from any building except those approved for the storage or servicing of such vehicles.
 - c. When, in case of breakdown or other emergency, the operator must leave the emergency.
- C. Tank vehicles shall not be parked or garaged in any building other than those specifically approved for such use by the concerned agency.

D. FIRE PROTECTION AND OTHER SAFETY MEASURES

1. Tank vehicles used for the transportation of any flammable or combustible liquids, regardless of the quantity being transported whether loaded or empty shall be conspicuously and legibly marked. Such marking shall display the following:
 - Vehicle manufacturer
 - Manufacturer's serial number
 - Date Manufacture
 - Original Test date
 - Certificate date
 - Design pressure
 - Head material
 - Shell material
 - Weld material
 - Lining material
 - Nominal tank capacity by compartment
 - Maximum product load
 - Loading limits
 - Unloading limits
2. These markings shall not be modified, obstructed, made inaccessible or unreadable by paints or any fixtures.
3. Installation of any plate onto the tank with these markings shall not compromise the safety of the tank
4. The size of signage shall measure at least two hundred seventy three millimeters (273mm) on both sides and have thirteen millimeters (13mm) inner solid line border. The text indicating the hazard and the hazard class should be at least forty-one millimeters (41mm)
5. Smoking is prohibited while driving, making deliveries, filling or making repairs to tank vehicles.
6. While loading or unloading, extreme care shall be taken to keep away fire and to prevent persons in the vicinity from smoking, lighting matches, or carrying any flame or lighted cigar, pipe or cigarette.
7. Each tank vehicle shall have at least one (1) unit of twenty pounds (20 lb) or two (2) units of ten pounds (10lbs) B-C-rating portable fire extinguisher.
8. Fire extinguishers shall be kept and maintained in good operating conditions at all times. They shall be visibly located in an accessible place on each tank vehicle and shall be protected from damage and impact.
9. Trailer/tank vehicle operators, contractors, drivers, handlers and crews shall have undergone proper qualification by a concerned agency. Crews shall include repair and maintenance personnel.

E. OTHER CONDITIONS

1. This permit must always be conveyed while the tank is in operation and should be SURRENDERED or RENEWED upon expiration.
2. Violation of any of the above conditions when the tank truck is loaded shall IPSCO FACTO immediately cause this Permit to become NULL and VOID and shall hold its operator or owner of the cargo truck liable to the penalties provided for by the RA 9514 or the Fire Code of the Philippines _____.

CONDITIONS:

A. OPERATION OF TANK VEHICLES

1. Cargo vehicle shall be at all times in good state of serviceability, devoid of accumulation of grease, oil or other flammable and from leaks.
2. Driver shall be thoroughly trained in the operation of tank vehicles and proper procedures for loading and unloading
3. Dome covers shall be closed and latched while the tank vehicle is in transit.
4. Repair of tank vehicles shall be made with caution. No repair shall be made when there is presence of hazard due to combustible vapors nor any loaded tank vehicle be repaired in a closed garage.
5. Cargo tank shall not be repaired using any method employing a flame, arc, or other sources of ignition, unless the tank is maintained vapor-free or otherwise made safe in an approved manner.

B. LOADING AND UNLOADING TANK VEHICLES

1. Flammable or combustible liquid shall not be transferred to or from any tank vehicles, unless the parking brake is securely set and all other reasonable precautions have been taken to prevent motion of the vehicle.
2. The driver, operator, or attendant of any cargo vehicle shall not leave the vehicle while it is being filled or discharged. Delivery hose, when attached to a tank vehicle, shall be considered to be part of the tank vehicle.
3. Engine of tank vehicles shall be shut down during the making or breaking hose connections. If loading or unloading is done without the use of a power pump, the tank vehicle motor shall be shut down throughout the operations.
4. Cargo tank or a compartment used for the transportation of any flammable or combustible liquid shall not be loaded liquid full. No tank vehicle compartments shall be loaded to a volume in excess of 99% of its capacity.
5. The driver, operator or attendant of any tank vehicle shall before making delivery to any tank, determine the unfilled capacity of such tank by a suitable gauging device. To prevent overfilling, he shall not deliver in excess of that amount.
6. During loading, hatch covers shall be secured on all compartments except in the receiving compartments.
7. The cargo vehicle shall be bonded to the fill pipe when loading. The bond-wire connection shall be made prior to opening the dome covers. It shall be maintained in place during the entire filling operation and the dome covers shall be securely closed before bond wire is disconnected from the tank vehicle. Tank vehicle and vehicle chassis shall be electrically bonded. Provisions shall be made in the truck structure for the bondage of vehicle to the fill pipe during vehicle loading operations. Hose shall be duplex metal lined or equivalent with approved shut-off nozzle and an adequate bonding cable securely closed before the bond wire is disconnected from the cargo truck.

C. PARKING AND GARAGING

1. No person shall leave a tank vehicle unattended on any street, highway, avenue or alley
2. No person shall park a tank vehicle at any one point for longer than one (1) hour except:
 - a. Off a street, highway, avenue or alley inside a bulk plant and seven and a half meters (7.5m) from the property line or

other government and non-government establishments.

To qualify as a member of fire brigade, individuals must be available to respond to fire alarms and attend required training programs, for this purpose and in accordance to Section 6.0.3.1 of the IRR of RA 9514, the Bureau of Fire Protection (BFP) issued Memorandum Circular Number 2009-017 re. Guidelines on the Issuance of Certificate of Competency (COC) for Fire Volunteers, Members of Fire Brigades, Fire Safety Practitioners and Organization dealing with Fire Safety. The COC shall be synonymous with the license to practice fire safety, thus no person shall be allowed to render fire safety or fire fighting services unless the requirements on certificate of competency are complied with.

The said provision of the law applies to all business establishments employing at least fifty (50) persons. Business establishments shall refer to all occupancies, government or private offices and buildings. Hence, all business establishments are mandatorily required to comply with this provision, among other fire safety requirements of the fire code, before they can be granted with Fire Safety Inspection Certificate (FSIC).

Relative thereto, all Regional Directors are hereby directed to ensure that said provisions of the law including the requirements of MC 2009-017, are properly observed within their areas of responsibility.

For strict compliance.

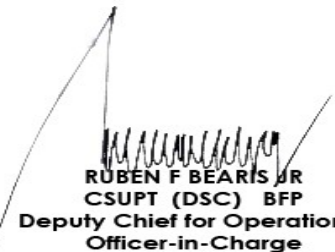

RUBEN F BEARIS JR
CSUPT (DSC) BFP
Deputy Chief for Operations/
Officer-in-Charge



Republic of the Philippines
 Department of the Interior and Local Government
BUREAU OF FIRE PROTECTION
NATIONAL HEADQUARTERS
 Agham Road, Brgy. Bagong Pag-asa, Quezon City



Republic of the Philippines
 DEPARTMENT OF THE INTERIOR AND LOCAL GOVERNMENT City or
 BUREAU OF FIRE PROTECTION Municipal
 NATIONAL HEADQUARTERS

**FIRE SAFETY CLEARANCE FOR
 CONVEYANCE OF HAZARDOUS MATERIALS AND
 CHEMICALS IN CARGO VEHICLES**

MEMORANDUM

TO : ALL REGIONAL DIRECTORS

SUBJECT : MONITORING OF FIRE CODE SALES TAX

DATE : October 15, 2012

This pertains to the issue raised during the 1st Semester Command Conference on September, 2012 regarding the absence of clear policy/directives in monitoring of fire code sales tax particularly of Ace Hardware and other similar business establishments selling fire fighting appliances. Fire Code Sales Tax refers to two percent (2%) of gross sales of companies, persons or agents selling firefighting equipment, appliances or devices, including hazard detection and warning system.

Be informed that the said issue has already been clarified in a Memorandum signed by then Chief, BFP, DIR. ROLANDO M BANDILLA, CESO IV, dated January 26, 2011. Hence, the under-signed reiterates the key points of the said Memorandum:

1. The assessment and collection of fire code sales tax is vested with the City/Municipal Fire Marshal over entities or companies selling firefighting equipment, appliances or devices including hazard detecting and warning system within his area of jurisdiction. An entity is within his jurisdiction if it is registered with its office as an entity conducting business, **the PRINCIPAL PLACE OF BUSINESS.**
2. The Fire Code Sales Tax should be based on the "gross sales" of companies, persons or agents selling fire-fighting equipment, appliances or devices, including hazard detection and warning systems. The term "**gross sales**" should include all **sales made by the company on a yearly basis.** This is to be determined

DATE

Control No. _____

This **CLEARANCE** is issued for the transportation / conveyance of Flammable Liquids by Cargo Tank to any point of delivery.

ISSUED TO _____
 ADDRESS _____
 TYPE OF VEHICLE _____ PLATE NUMBER _____
 MOTOR NUMBER _____ CHASSIS NUMBER _____
 NAME OF DRIVER: _____ LICENSE NUMBER _____
 If with trailer, TRAILER NUMBER _____
 QUANTITY & DESCRIPTION _____
 Destination shall be from Terminal to _____

This clearance is granted subject to substantial compliance with Section 10.3.1.2, Division 2, Chapter 3, Rule 10 of the Implementing Rules and Regulations of Republic Act 9514, otherwise known as Fire Code of the Philippines of 2008 for the storage of hazardous materials and chemicals and conditions stated at the back hereof

This **CLEARANCE** expires on _____

Recommending Approval:

Approved by:

 Chief, Fire Safety Enforcement Section

 City Fire Marshal

Fee: P _____
 O.R. No. _____
 Date issued _____
 Issued on _____

NOTE:

1. NOT VALID WITHOUT DRY SEAL, WITH ALTERATIONS AND WITH ERASURES. THIS CERTIFICATE IS NON-TRANSFERABLE.
2. Violation of aforementioned laws shall IP SO FACTO immediately cause this Permit to become NULL AND VOID

"economic and socialized housing units" with the modifier "adequate." Fire calamity chooses no color, no age, no economic or social standing, this is the very wisdom behind the cross-cutting and horizontal application of the Fire Code. Hence, the policy behind B.P. Big. 220 itself makes it abhorrent to sacrifice "adequacy", which includes compliance with the minimum mandatory requirements for fire protection as deemed wise and necessarily by the BFP, in the interest of lowering construction costs.

When PHINMA agreed to the economic and socialized housing contract approved under B.P. Big. 220, it agreed not only to build or construct economic and socialized housing for the underprivileged but to build and construct adequate ones that are fit and safe for human occupancy. In other words, PHINMA also agreed to take on the equally significant social and moral responsibility inherent to the said project under B.P. Big. 220.

It does not escape our notice the laudable effort of PHINMA to propose alternative remedies in lieu of the required AFSS. However, as aptly pointed out by BFP, the exemption sought cannot be granted, for to do so is tantamount to undermining the policy of the stated in ensuring public safety.

In sum, while PHINMA projects were approved under B.P. Big. 220, a law, which has been in effect since 1982, PHINMA cannot hide behind the cloak of the 15-meter bar in order to exempt itself from the all-too-important AFSS requirement. R.A. No. 9514, which came into effect in 2008, - prevails insofar as fire safety requirements are concerned. The "4-storey or more" standard, therefore, prevails.

Please be guided accordingly.

Very truly yours,

LEILA M. DE LIMA
Secretary

by the City/Municipal Fire Marshal having jurisdiction based on their gross receipts.

3. The company involved in selling of fire fighting appliance should settle payment of the said tax for them to be issued with Fire Safety Inspection Certificate (FSIC).
4. Further, for "branches or local offices" such as in the case of ACE Hardware, the manager/administrator, in addition to other fire code requirements, shall show a proof that fire code sales tax has already been settled by their main or principal office before they can be grant of FSIC.

For guidance, information and widest dissemination.

RUBEN F BEARIS JR
CSUPT (DSC) BFP
**Deputy Chief for Operations/
Officer-in-Charge**



Republic of the Philippines
 Department of the Interior and Local Government
BUREAU OF FIRE PROTECTION
NATIONAL HEADQUARTERS



Agham Road, Brgy. Bagong Pag-asa, Quezon City

MEMORANDUM

TO : ALL REGIONAL DIRECTORS

SUBJECT :GUIDELINES IN THE PROCESSING OF FIRE SAFETY INSPECTION CERTIFICATE (FSIC) DURING RENEWAL OF BUSINESS PERMITS SPECIFICALLY IN AREAS WHERE ONE-STOP-SHOP IS BEING IMPLEMENTED

DATE :24 September 2012

I. BACKGROUND

Pursuant to Rule 9 Division 4 Section 9.0.4.1 Implementing Rules and Regulation (IRR) of Republic Act 9514 otherwise known as the Fire Code of the Philippines of 2008, which categorically states that "Upon compliance of the fire safety requirements under Rule 10 of this IRR, a Fire Safety Inspection Certificate (FSIC) shall be issued by the BFP as a pre-requisite for the issuance of Business or Mayor's Permit, Occupancy Permit, PHILHEALTH Accreditation for Hospitals, DOH License to Operate and other licenses issued by other government agencies."

In line with the tenets of the Fire Code, the BFP Local Offices/Fire Stations then designates the task to the Fire Safety Inspector's (FSI's) of conducting inspection of a building or structure within their area of responsibility each time the owner, administrator or occupant shall renew his/her business permit or permit to operate as a requirement for the issuance of FSIC which in the same way is a pre-requisite in granting business permits as stipulated in Section 4.0.0.3 A (4 and 5) of the IRR of RA 9514.

Applying the provisions indicated under the Fire Code,

"CHAPTER 2. FIRE SAFETY IN BUILDINGS. STRUCTURES AND FACILITIES

"DIVISION 1. SCOPE

"A. This Chapter deals with life safety from fire and like emergencies in buildings, structures and facilities. It covers construction, protection and occupancy features to minimize danger to life from fire, smoke, vapor and fumes before buildings are vacated. It also discusses procedures and guidelines in fire drills required for all types of occupancies to prevent panic in times of emergencies. It specifies the number, size, and arrangement of means of egress sufficient to permit prompt and safe escape of occupants from buildings, or structures or facilities in case of fire or other conditions dangerous to life and property." (Emphasis supplied)

In addition to the foregoing, no less than the State Principles and State Policies mentioned in Sections 5 and 9, Article II of the Constitution, mandates the primacy of certain considerations, to wit:

"The maintenance of peace and order, the protection of life, liberty, and property, and promotion of the general welfare are essential for the enjoyment by all the people of the blessings of democracy.

XXX XXX XXX

"The State shall promote a just and dynamic social order that will ensure the prosperity and independence of the nation and free the people from poverty through policies that provide adequate social services, promote full employment, a rising standard of living, and an improved quality of life for all." (Emphasis supplied)

On the other hand, while R.A. No. 9514 was meant to address, among other things, the worsening fire casualty statistics in the country, B.P. Big. 220 was crafted due to the subsisting and omnipresent chronic problem of poverty, thus, the policy of said law, to wit:

"SECTION 1. It is hereby declared a policy of the Government to promote and encourage the development of economic and socialized housing projects, primarily by the private sector, in order to make available adequate economic and socialized housing units for average and low-income earners in urban and rural areas." (Emphasis supplied)

It is not for nothing that B.P. Big. 220 itself qualifies the phrase

The 15-meter criterion may have been the prevailing generally accepted standard at the time the B.P. Big. 220 IRR was revised in 2001, which was when the old Fire Code was still in effect.

However, with the passage of R.A. No. 9514 and its IRR, which prescribed standards that "shall [not] be construed to prohibit a better type of design, building construction, more exits, or otherwise safer conditions than the requirements specified in [Chapter 2, Rule 10 thereof]" (i.e., minimum standards) there is no other possible conclusion other than that the agency recognized by the law as having the required expertise on fire safety measures (i.e., the BFP) has read what are to be considered as "within the generally accepted levels of safety"; hence, the 4-storey or more/more than 12 units criterion to supplant the old 15-meter benchmark.

Finally, this conclusion is also supported by the principle in statutory construction summed up in the Latin maxim "ratio legis est anima" (the reason for the law is its very soul), which dictates that, in construing provisions of statutes, the policies of the law should prevail.

We need not reiterate the obvious significance of the Fire Code and its IRR. The State's policy of ensuring public safety and promotion of economic development through the prevention and suppression of all kinds of destructive fire (Section 2 quoted above) is a non-negotiable fact. On the other hand, the *raison d'être* for the various safety requirements detailed in the IRR, including the mandatory requirement of automatic fire detection and alarm system for certain types of buildings, may be gleaned from certain provisions under Rule 10 of the

IRR, thus:

"RULE 10. FIRE SAFETY MEASURES

'CHAPTER 1. COVERAGE

"This Rule covers the Fire Safety Measure for Buildings, Structures and Facilities, Hazardous Materials and Wastes, Hazardous Operations and Processes and Miscellaneous Hazardous Premises and/or conditions, that by its very nature or relation to life, property and environment poses threat or danger.

the phase of securing a FSIC covers a minimum period of five (5) days processing commencing from application until the issuance of the FSIC. However, with the emergence of several Business Permit Licensing Offices (BPLO) of local government agencies/units which are all offering a one-stop-shop system in the renewal of permits and licenses for the convenience of the applicants, it is appropriate for the BFP to adjust to the demands of this times and work on delivering improved service to the public by coming up with a proposal of implementing a one stop shop scheme for expediency and feasibility. With this modification, BFP becomes more responsive and effective in its commitment of providing better services by employing specific guideline such as a "One Stop Shop Policy" in the issuance of Fire Safety Inspection Certificate (FSIC).

II. PURPOSE

A. To hasten the issuance of FSIC for the benefit of the applicants in the renewal of their permits and/or licenses.

B. To improve the quality of service provided to the applicants by implementing a policy for the expeditious administration of applications.

C. To give ample time for applicants in correcting any violations previously identified by Fire Safety Inspectors as to avoid delay in the processing of their applications

D. To manage and reduce the work load of all BFP Local Offices/Fire Stations by giving prompt service to applicants.

III. PROCEDURE

1. All City/Municipal Fire Marshall having jurisdiction shall observe periodic fire safety inspection of any building, structure and establishment two (2) or three (3) months in advance before the scheduled renewal of any permits or licenses by the BPLO in pursuant to Section 7 of RA 9514.

2. All Fire Safety Inspection Certificates (FSIC) for business or permit to operate shall have a validity of 365 days or one (1) year from the date of issuance unless

revoked/cancelled for justifiable cause in accordance to Rule 13 of the Implementing Rules and Regulations (IRR) of RA 9514;

3. Only buildings, structures and establishments found to have no violation during the periodic inspection and with valid FSIC shall be recommended for issuance of business or permit to operate provided that pertinent fire code fees are collected;

4. Proof of payment of the following fire code revenues, whenever applicable, shall be presented in addition to the other documentary requirements prior to the granting of business permit, to wit:

- a. Fire safety inspection fee
- b. Fire code construction tax
- c. Fire code realty tax
- d. Fire code premium tax
- e. Fire code sales tax
- f. Fire code proceed tax
- g. Storage clearance fee
- h. Conveyance clearance fee
- i. Other fees

5. All buildings, structures and establishments found to have violated any provisions of the fire code shall only be recommended for issuance of business permit upon correction of the violations noted in the periodic inspection;

6. All City/Municipal Fire Marshals shall ensure that all buildings, structures and establishments with issued business permit during the one stop shop are inspected within three (3) days upon receipt of payment of pertinent fire code fees; and

7. All Regional Directors are responsible for the dissemination, information and implementation of this guideline to give better services to the owner, administrator or occupant of buildings, structures and establishments who shall renew his/her permits and/or licenses.

schedule of fees/fire service charges and administrative penalties therefore as provided in the pertinent provisions of the Fire Code.

Hence, between the earlier law, B.P. Big. 220, and the IRR issued by the Housing and Land Use Regulatory Board (HLURB) on the one hand; and the later and more specific special law relating to fire prevention and suppression, and the IRR issued by the Bureau of Fire Protection on the other, we have no reservations in stating that the latter law and the IRR issued by the latter agency, which was mandated by said law to administer and enforce its provisions, supersedes conflicting provisions found in the earlier law.

This conclusion is further reinforced by the fact that the IRR of B.P. Blg. 220 relied upon by PHINMA cites, in its preambular portion, Presidential Decree (P.D.) No. 1185 or the old Fire Code as one of the bases for its issuance, thus:

"Pursuant to Section 3 of BP 220, the Housing and Land Use Regulatory Board is authorized to establish and promulgate two levels of standards and technical requirements for the development of economic and socialized housing projects/units in urban and rural areas from those provided in PD 957, PD 1216, PD 1096, and PD 1185, hence the following rules are hereby promulgated." [Emphasis supplied]

Such law, P.D. No. 1185, was expressly repealed by Section 15 of R.A. No. 9514, which also expressly states that "all... rules and regulations insofar as they are inconsistent with [said] Act, are hereby repealed or amended as the case may be." Hence, the certain provisions of the IRR for B.P. Big. 220, which were issued on the basis of, among others, P.D. No. 1185, and which are inconsistent with those set forth in R.A. No. 9514, are deemed repealed or amended.

Further support for the conclusion that the fifteen (15)-meter criterion has been superseded is found in Section 4 of the IRR of B.P. Big. 220 itself, which states that one of the basis for minimum design standards set forth therein are the "generally accepted levels of safety", and lists, first and foremost among the parameters used in formulating such design standards, the consideration for the **"protection and safety of life, limb, property and general public welfare "**

units, automatic fire detection and alarm systems are required.

The requirement, to emphasize, is mandatory based on the language used in the above-quoted provisions in the IRR, which uses the words "shall" and "mandatory" in prescribing such requirement. The only exceptions appear to be, as follows:

- (1) buildings provided with approved, supervised sprinkler protection in accordance with Section 10.2.6.5 of the IRR;
- (2) buildings that are equipped with "better type of design, building construction, more exits, or otherwise safer conditions than the requirements specified in" Chapter 2, Rule 10 of the IRR; and
- (3) in case of existing buildings only, which when forced to comply will compromise the structural stability/integrity, the Chief, BFP may accept adequate alternative and/or remedial fire safety measures in lieu of the fire safety requirements of this IRR upon application by the owner/occupant/building administrator of the building or structure.

In so holding, we note, first and foremost, the primacy of R.A. No. 9514, otherwise known as the Revised Fire Code of the Philippines of 2008, insofar as prescribing minimum fire safety standards and requirements is concerned, pursuant no less to the policy of the State, as stated in Section 2 thereof, to wit:

"SECTION 2. It is the policy of the State to ensure public safety, promote economic development through the prevention and suppression of all kinds, of destructive fires, and promote the professionalization of the fire service as a profession. Towards this end, the State shall enforce all laws, rules and regulations to ensure adherence to standard fire prevention and safety measures, and promote accountability in the fire protection and prevention service." [Emphasis supplied]

Such primacy of the Fire Code translates into a concomitant primary of the authority of the Chief of the BFP, with the approval of the Secretary of the Interior and Local Government (SILG), to issue rules and regulations and prescribe standards,

IV. EFFECTIVITY

All Memorandum Circular inconsistent herewith are hereby amended accordingly.

This guideline shall take effect immediately upon approval.



RUBEN F BEARIS JR
CSUPT (DSC) BFP
**Deputy Chief for Operations/
Officer-in-Charge**

A letter reply to Ma. Consorcia L Tamayo requesting for 60-day extension to comply with the proposed alternative/remedial fire safety measures in lieu of automatic sprinkler system

April 16, 2012

Ma. Consorcia L Tamayo

Board Member, UPH-Jonelta System
Perpetual Help Hospital of Manila
1504 Laon-laon cor. Gelinosa St., Sampaloc, Manila

Dear Madame;

This pertains to your request for a 60-day extension to comply with your proposed action plan in lieu of automatic sprinkler system to be installed in your building (University of Perpetual Hospital) located at 1504 Laon-laon cor. Gelinosa St., Sampaloc, Manila which has standing Closure Order issued by CSUPT SANTIAGO E LAGUNA on October 13, 2011 for failure to comply among others the installation of automatic sprinkler system. You further claim as certified by your Professional Structural Engineer that your building is not structurally capable of having an automatic sprinkler system because it might compromise the building structure, hence, you proposed for alternative plan of corrections.

Please be informed that the procedure in the granting of alternative and/or remedial fire safety measures shall be coursed through the City/Municipal Fire Marshal for pre-evaluation and endorsement to the BFP higher offices. Only the Chief, BFP may approve the alternative and/or remedial fire safety measures in lieu of the fire safety requirements in the installation of automatic fire suppression system provided further that any aggrieved party may appeal to the Secretary, DILG. An alternative fire safety plan shall first be approved by the BFP before the requesting party can start installing or constructing its alternative and/or remedial fire safety measures.

Hence, we regret to inform you that your request for 60 days extension cannot be granted for failure to observe the BFP's established procedure relative to this case. Moreover, we request you to coordinate with the local BFP station within your area in your

On your second query as to which standard is applicable to the subject projects of PHINMA, whether it is the "four (4) storeys or more in height" or "more than twelve (12) apartment units" criterion set forth in the Fire Code or the "15-meter or more" in height benchmark under B.P. Big. 220, we bring your attention to the following legalities.

PHINMA cites as basis for their request for exemption the provision in the IRR of B.P. Big. 220 which requires the installation of an automatic fire alarm and suppression system for buildings that are 15 meters or more in height. It claimed that since its projects are covered by B.P. Big. 220, this is the benchmark that would determine whether the mandatory AFSS requirement is applicable to such projects. Hence, although its Medium Rise Buildings (MRB) consists of five (5) storeys with a total of 29 units, the same is still exempt from the mandatory AFSS requirement because the total height of the building is only 12.7s meters owing to the lower floor-to-floor height of only 2.55 meters.

On the other hand, this conflicts the above-quoted provisions of the Fire Code and its IRR, which, as already stated, is mandatorily applicable to "all persons and all private and public buildings, facilities or structures erected or constructed before and after its effectivity," and which provides that the applicable criterion, insofar as the requirement for automatic fire detection and alarm system is concerned, is the number of storeys (i.e., 4 or more) or the number of total units [i.e., more than 12] in the building.

In resolving such conflict, the Department is of the opinion that the provisions in B.P. Big. 220 (which was enacted in 1982) and in its Revised IRR (which came into effect in 2001) insofar as they are in conflict with specific provisions and requirements in R.A. No. 9514 (which passed into law in 2008), and its IRR (which came into effect in 2009), have been repealed by the latter law and IRR.

In other words, we are of the opinion that the effective and applicable criterion in determining whether or not an automatic fire detection and alarm system is required for the projects of PHINMA is either the "four (4) storeys or more" or "more than twelve (12) apartment units" criterion in the IRR of R.A. No. 9514. Hence, since its Medium Rise Buildings consist of 5 storeys and 29

through central station accredited by the BFP shall be mandatory to the following types of occupancy:

"a. xxx

"b. XXX .

"c. All educational institutions, hotels and apartment buildings (condominium) of at least four (4) storey in height; xxx

xxx xxx xxx

"SECTION 10.2.12.4 APARTMENT BUILDINGS

"A. General Requirements — xxx

"B. Exit Details — xxx

"C. Protection —

xxx xxx xxx

4. Alarm Systems — xxx

"a. Every apartment building of four (4) storeys or more in height, or more than twelve (12) apartment units shall have an automatic fire detection and alarm system in accordance with Section 10.2.6.4 of this IRR, except buildings provided with approved, supervised sprinkler protection in accordance with Section 10.2.6.5 of this IRR.

"b. Apartment buildings of not more than three (3) storeys in height shall be provided with manual fire alarm system, provided that dwelling units shall be installed with single - station or multi station smoke detectors." (Emphasis supplied).

The provisions of the Fire Code and of the IRR defining their respective scope cannot be more explicit, they shall apply to all persons and all private and public buildings, facilities or structures erected or constructed before and after their respective dates of effectivity.

case is Manila Fire District for evaluation of your proposed alternative fire safety plan. However, we lay stress that pending the approval of your request for alternative and/or remedial fire safety measures, the closure order previously issued by the Regional Director is still executory.

Hoping that this merit your feat to a safe and compliant operation.

Sincerely yours,

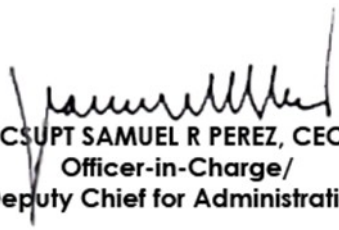

F/CSUPT SAMUEL R PEREZ, CEO VI
Officer-in-Charge/
Deputy Chief for Administration

A letter reply to Mr. Nepomuceno regarding his requests clarification on the basis for computing fire safety inspection fee.

April 16, 2012

MR. PEDRITO M NEPOMUCENO
4F R.G. Castelo Building
219 Apo St., Barangka Ilaya
1550 Mandaluyong

Dear Mr. Nepomuceno:

Greetings of peace and happiness!

We have received your letter dated February 17, 2012 addressed to SEC. JESSE ROBREDO, DILG which was referred to this office by Att. Domnina Rances, Head, Executive Assistant, DILG regarding the following issued, to wit:

1. What exactly is the basis for computing fire safety inspection fee? And, why the following items, such as Sanitary Inspection Fee, Environment Inspection Fee, Garbage Collection Fee and Fire Inspection Fee (Local Ordinance) are included in the assessment of fire safety inspection fee?
2. What is the justification for the inclusion of the above items in the assessment of fire safety inspection fee? What is there to be inspected by the BFP?
3. Does the local ordinance imposing similar fire inspection fee have legal basis?

First Issue and Second Issue, since they are related:

The pertinent provision of the Fire Code of the Philippines of 2008 regarding the basis of fire safety inspection fee is provided under Section 12.0.0.2 of the IRR of the Code which reads, "A. The classification of Fire Code revenues and rates are prescribed in the following schedule: xxx... 6. Fire Safety Inspection Fee. Fee charged for the conduct of Fire Safety Inspection equivalent to ten per centum (10%) of all fees charged by the building official, or by the Local Government or by other government agencies concerned in the granting of pertinent permits or licenses. Xxx..." (Underscores ours)

- mable liquids and gases, toxic and other hazardous materials and operations, and their wastes;
 - "E. Fire safety planning, design, construction, repair, maintenance, rehabilitation and demolition;
 - "F. Fire protective and warning equipment or systems;
 - "G. All land transportation vehicles and equipment, ships or vessels docked at piers or wharves or anchored in seaports; and
 - "H. Petroleum industry installations.
- XXX XXX XXX

"RULE 10. FIRE SAFETY MEASURES

XXX XXX XXX

"CHAPTER 2. FIRE SAFETY IN BUILDINGS. STRUCTURES AND FACILITIES

XXX XXX XXX

"DIVISION 6. FEATURES OF FIRE PROTECTION

XXX XXX XXX

"SECTION 10.2.6.4 FIRE DETECTION, ALARM, AND COMMUNICATION SYSTEMS

"A. General — xxx

"B. Signal Initiation —

"1 . As provided in Divisions 8 through 17 of this Chapter, activation of the complete fire alarm system shall be initiated by, but not be limited to, any or all of the following means of initiation;

"a. Manual initiation.

"b. Automatic detection.

"c. Extinguishing system operation.

"C. Smoke Alarms — xxx

"D. Occupant Notification — xxx

"E. Emergency Forces Notification —

"1.xxx

"2. xxx

"3. Automatic fire department notification

Pertinent provisions of R.A. No. 9514 read, as follows:

"Section 4. Applicability of the Code. — The provisions of the Fire Code shall apply to all persons and all private and public buildings, facilities or structures erected or constructed before and after its effectivity.

XXX XXX XXX

"Section 7. Inspections, Safety Measures, Fire Safety, Constructions, and Protective and/or Warning Systems. — As may be defined and provided in the Rules and Regulations, owners, administrators or occupants of buildings, structures and their premises or facilities and other responsible persons shall be required to comply with the following, as may be appropriate:

XXX XXX XXX

"d. Provision on Fire Safety Construction, Protective and Warning System. — Owners, occupants, or administrator of buildings, structures and their premises or facilities, except such other building or structures as may be exempted in the rules and regulations to be promulgated under Section 5 hereof, shall incorporate and provide therein fire safety construction, protective and warning system, and shall develop and implement fire safety programs, to wit: xxx" [Emphasis supplied]

On the other hand, relevant portions of the IRR are as follows:

"RULE 2. COVERAGE "

"This IRR shall cover the following:

- "A. All persons;
- "B. All private or public buildings, facilities or structures and their premises erected or constructed before and after the effectivity hereof;
- "C. Design and installation of mechanical, electronics and electrical systems relative to fire protection;
- "D. Manufacturing, storage, • handling and/or use, and transportation of explosives and/or combustible, flam-

The foregoing provision should be interpreted in the light of the authority of the BFP to issue a Fire Safety Inspection Certificate (FSIC) as prerequisite to the grant of permit or license provided under Section 9.0.4.1 of the Code, which reads:

"Upon compliance of the fire safety requirements under Rule 10 of this IRR, a Fire Safety Inspection Certificate (FSIC) shall be issued by the BFP as a pre-requisite for the issuance of Business or Mayor's Permit, Permit to Operate, Occupancy Permit, PHILHEALTH Accreditation for Hospitals, DOH License to Operate and other permits or licenses being issued by other government agencies"

As can be gleaned above, there are different kind of FSIC being issued by the BFP DEPENDING ON THE NATURE AND PURPOSE OF THE fsic BEING APPLIED FOR. That is why Section 12.0.0.2 of the IRR of the Code uses the conjunctive word "or" as basis in computing the pertinent fire inspection fee. Thus, in answering the first issue regarding the exact basis of fire inspection fee; it varies depending on the FSIC being applied for, which could be summarized as follows:

If the FSIC being applied is for Business or Mayor's Permit, the fee should be based on 10% of all fees charged by the Local Government (i.e. Mayor's Permit Fee, sanitary Inspection Fee, Environmental Inspection Fee, garbage Collection Fee, Fire Inspection Fee (local ordinance), and other fees being collected by local government in granting said permit);

If it is for Occupancy Permit, the fee should be based on 10% of all fees charged by the Building Official (i.e. Building Inspection Fee, Electrical Inspection Fee, Mechanical Inspection fee, Plumbing Inspection Fee) and

If it is for the purpose of obtaining permit or license from other concerned government agency, it should be base on 10% of all fees charged by such government agency in the granting of pertinent permits or licenses.

Likewise, section 12.0.0.2 of the IRR of the Code uses the word "10% of all fees." It is basic in statutory construction that where the law does not distinguish, we should not also distinguish. Thus, for purposes of obtaining mayor's or Business Permit, the basic in computing the fire inspection should be based on all fees being charged by the local Government including all regulatory fees through its local ordinance (which may also include Building Inspection Fee, Electrical Inspection fee, Mechanical Inspection fee and Plumbing Inspection Fee, other than those charged by the building official on granting Building or Occupancy Permit) in granting Mayor's or Business Permit. However, if those fees such as Build-

ing Inspection Fee, Electrical Inspection Fee, Mechanical Inspection Fee and Plumbing Inspection Fee are not being charged by the local government in granting said permit, then they should be excluded.

Hence, in answering the second issue and as pointed out earlier; the inclusion of Sanitary Inspection Fee, Environmental Inspection Fee, Garbage Collection Fee, and Fire Inspection Fee in the assessment of Fire Inspection is justified by the use of the word "10% of all fee." To reiterate and emphasize, the determining factor as to the basis of the computation or fire inspection fee on the kind of FSIC being applied for.

Third Issue:

Please be informed that in so far as the third issue is concerned, regarding the legality of the local ordinance imposing fire inspection fee, it is already beyond the purview of our mandate to pass upon the issue.

We hope to enlighten you on this matter. Should you have other concern, please do not hesitate to communicate further with us.

Very truly yours,



DANILO R BARADI
CSUPT (DSC) BFP

Director for Fire Safety and Prevention

requirement under the Fire Code.

In support of its request for exemption, PHINIVIA submitted the following justification:

"The building technology we adopted is a box system/load bearing structure without columns and beams. The system will have a lower floor to floor height of only 2.55 meters and a 5 storey building will have a total building height of 12.75 meters. Hence, under B.P. Big. 220 standards, AFSS is not required. However, the Fire Code of 2008 requires AFSS for buildings with height of more than 15 meters and more than 4 storey.

"We therefore would like to request that the Fire Code of 2008 will allow variance and exemption for projects approved under B.P. Big. 220 standards particularly on AFSS requirement. That AFSS will not be required for buildings with height of not more than 15 meters and 5 storey or lower. It will only require AFSS for buildings of more than 5 storey and more than 15 meters in height." (Emphasis supplied)

The Bureau of Fire Protection (BFP), on the other hand, which already had opportunity to rule on the matter, denied the exemption sought by PHINMA, hence, your request for this Department's opinion.

With respect to the first issue you raised, the Department is of the opinion that the subject project of PHINMA is covered by the provisions of R.A. No. 9514 (Fire Code) and, thus, is not exempted from compliance with the Automatic Fire Suppression System (AFSS) requirement under the Fire Code

The answer lies in the express provisions of R.A. No. 9514 itself, particularly Section 4 on "Applicability of the Code" and Section 7 on "Inspections, Safety Measures, Fire Safety, Constructions, and Protective and/or Warning Systems," as well as of its Implementing Rules and Regulation (IRR), which was issued pursuant to Section 14 in relation to Section 5 of the law.

Department of Justice's opinion on whether economic and socialized housing projects under Batas Pambansa (B.P. Blg. 220 are covered by Republic Act 9514 (the "Fire Code"), or whether they are exempt from the Automatic Fire Suppression System requirement, and Whether or not the height standard set for AFSS requirement is that of a four-storey (4-storey) or more building, or a fifteen-meter (15-meter) bar.

Republika ng Pilipinas
KAGAWARAN NG KATARUNGAN
Department of Justice
Manila

LML-L-O4FI2- 462

4 June 2012

Secretary JESSE M. ROBREDO

Department of Interior and Local Government
EDSA cor. Mapagmahal St.,
Diliman, Quezon City

Dear Secretary Robredo:

This refers to your query on the following:

(1) Whether economic and socialized housing projects approved under Batas Pambansa (B.P.) Blg. 220 are covered by Republic Act (R.A) No. 9514 (the "Fire Code"), or whether they are exempt from the Automatic Fire _ Suppression System (AFSS) requirement under the latter law; and

2) Whether or not the height standard set for AFSS requirement is that of a four-storey (4-storey) or more building, or a fifteen-meter (15-meter) bar.

A review of your request and its attachments show that PHINMA Properties, Inc., (PHINMA), whose economic and socialized housing projects were approved under B.P. Blg. 220, is seeking exemption from your Office from compliance with the AFSS

Letter reply to Atty Chito M. Cruz seeking opinion/comment relative to the: (a) fire safety requirement under the fire code and, (b) on the Elevator Requirement, relative to the recommendation of DPWH on the optimum level of medium-rise buildings for the Informal Settler Families (ISFs) in Metro Manila.

11 July 2012

Atty. Chito M Cruz
General Manager
National Housing Authority

Dear Atty. Cruz:

Greetings!

This pertains to your letter dated 06 June 2012 addressed to Hon. Jesse M Robredo, Secretary, DILG which was referred to the Bureau of Fire Protection (BFP) on 18 June 2012, seeking an opinion/comment relative to the: (a) fire safety requirement under the fire code and, (b) on the Elevator Requirement, relative to the recommendation of DPWH on the optimum level of medium-rise buildings for the Informal Settler Families (ISFs) in Metro Manila.

Fire Safety requirement under the Fire Code:

The issue on fire safety requirement of the Fire Code was also raised by PHINMA, where it requested the BFP for the approval of their alternative measures in lieu of sprinkler system and invoked BP220, but the same was denied by the BFP. Hence, it was brought to the Department of Justice for its legal opinion, to resolve the following issues:

1. Whether economic and socialized housing projects approved under Batas Pambansa (B.P.) Blg. 220 are covered by RA 9514 (Fire Code of 2008), or whether they are exempt from the Automatic Fire Suppression System (AFSS) requirement under the law; and
2. Whether or not the height standard set for AFSS re-

quirement is that of a four-storey (a-storey) or more building, or a fifteen-meter (15-meter) bar.

On 04 June 2012, Hon. Leila M. De Lima, Secretary, DOJ, issued her legal opinion, LML-L-04F12-462. On the first issue, she opined that, "... the Department is of the Opinion that the subject project of PHINMA is covered by the provision of R.A. 9514 (Fire Code) and, thus, is not exempted from compliance with the Automatic Fire Suppression System (AFSS) requirement under the Fire Code." Likewise, as the second issue the Honorable Secretary concludes that, "... xxx... In sum, while PHINMA projects were approved under B.P. Big. 220, a law, which has been in effect since 1982, PHINMA cannot hide behind the cloak of the 15meter bar in order to exempt itself from the all-too-important AFSS requirement. R.A. No. 9514, which came into effect in 2008, prevails in so far as fire safety requirements are concerned. The "4-storey or more" standard therefore, prevails."

Hence, as explained above, in so far as the fire safety requirements are concerned, the provisions of the Fire Code of 2008 prevails over BP 220. Thus, the requirements for automatic fire detection and alarm system under Section 10.2.12.4 for 4-storey building are required, regardless of whether it is less than 15 meters in height.

(b) Elevator requirement:

With regard to the issue on the elevator requirement, the pertinent provision regarding the elevator is provided under para. A, Section 10.2.7.5 of the IRR of RA 9514, which reads:

"A. Elevator installations shall be in accordance with the PSME Code.

B. All new elevators shall conform to the firefighters' emergency operations requirements of ASME A17.1 Safety Code for Elevators and Escalators except buildings of less than 5-storeys in height.

C. Elevators shall be subject to periodic inspections and tests by building management, without prejudice to the power or authority of the BFP to conduct inspections. All elevators equipped with firefighters' emergency operation in accordance

with paragraph (2) hereof shall be subject to a monthly operation with a written record of the findings made and kept by the building management. Such record shall be included in the submission of FALAR 3."

Plain reading of the above quoted provision reveals, that the same merely states that elevator installation shall be in accordance with the PSME Code. But nothing in the Fire Code that expressly and mandatorily requires any five (5) -storey or more building to be provided with elevator. Thus, we submit that, insofar as the IRR of BP 220, as you have quoted in your letter, expressly states that "Provision of elevators shall be required for buildings 6 storeys and beyond," the same should be the controlling law.

Hence, we disagree with the footnote to the table of cost comparison from the DPWH indicating that, "... the stricter provision of R.A. 9514 requiring elevator for a 5-storey building, shall prevail;" since, as pointed out above, nothing in the RA 9514 and its IRR which made it a mandatory requirement for 5-storey or more buildings to install an elevator.

We hope to have clarified and enlightened you on said issue.

Sincerely yours.

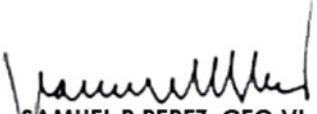

SAMUEL R PEREZ, CEO VI
CSUPT (DSC) BFP
Officer-in-Charge/
Deputy Chief for Administration