

First Edition, last update January 18, 2006

Lessons In Electric Circuits, Volume VI – Experiments

By Tony R. Kuphaldt

First Edition, last update January 18, 2006

©2002-2009, Tony R. Kuphaldt

This book is published under the terms and conditions of the Design Science License. These terms and conditions allow for free copying, distribution, and/or modification of this document by the general public. The full Design Science License text is included in the last chapter.

As an open and collaboratively developed text, this book is distributed in the hope that it will be useful, but **WITHOUT ANY WARRANTY**; without even the implied warranty of **MERCHANTABILITY** or **FITNESS FOR A PARTICULAR PURPOSE**. See the Design Science License for more details.

Available in its entirety as part of the Open Book Project collection at:

www.ibiblio.org/obp/electricCircuits

PRINTING HISTORY

- **First Edition:** Printed in April 2002. Source files written in *SubML* format. SubML is a simple markup language designed to easily convert to other markups like \LaTeX , HTML, or DocBook using nothing but search-and-replace substitutions.

Contents

1	INTRODUCTION	1
1.1	Electronics as science	1
1.2	Setting up a home lab	3
1.3	Contributors	12
2	BASIC CONCEPTS AND TEST EQUIPMENT	15
2.1	Voltmeter usage	15
2.2	Ohmmeter usage	21
2.3	A very simple circuit	28
2.4	Ammeter usage	35
2.5	Ohm's Law	42
2.6	Nonlinear resistance	45
2.7	Power dissipation	48
2.8	Circuit with a switch	53
2.9	Electromagnetism	55
2.10	Electromagnetic induction	57
3	DC CIRCUITS	59
3.1	Introduction	59
3.2	Series batteries	60
3.3	Parallel batteries	63
3.4	Voltage divider	67
3.5	Current divider	78
3.6	Potentiometer as a voltage divider	87
3.7	Potentiometer as a rheostat	93
3.8	Precision potentiometer	99
3.9	Rheostat range limiting	102
3.10	Thermoelectricity	109
3.11	Make your own multimeter	112
3.12	Sensitive voltage detector	117
3.13	Potentiometric voltmeter	122
3.14	4-wire resistance measurement	127
3.15	A very simple computer	131
3.16	Potato battery	136

3.17	Capacitor charging and discharging	138
3.18	Rate-of-change indicator	142
4	AC CIRCUITS	145
4.1	Introduction	145
4.2	Transformer – power supply	147
4.3	Build a transformer	151
4.4	Variable inductor	153
4.5	Sensitive audio detector	155
4.6	Sensing AC magnetic fields	160
4.7	Sensing AC electric fields	162
4.8	Automotive alternator	164
4.9	Induction motor	170
4.10	Phase shift	174
4.11	Sound cancellation	177
4.12	Musical keyboard as a signal generator	180
4.13	PC Oscilloscope	183
4.14	Waveform analysis	186
4.15	Inductor-capacitor "tank" circuit	188
4.16	Signal coupling	191
5	DISCRETE SEMICONDUCTOR CIRCUITS	199
5.1	Introduction	200
5.2	Commutating diode	201
5.3	Half-wave rectifier	203
5.4	Full-wave center-tap rectifier	211
5.5	Full-wave bridge rectifier	216
5.6	Rectifier/filter circuit	219
5.7	Voltage regulator	225
5.8	Transistor as a switch	228
5.9	Static electricity sensor	233
5.10	Pulsed-light sensor	236
5.11	Voltage follower	239
5.12	Common-emitter amplifier	244
5.13	Multi-stage amplifier	249
5.14	Current mirror	253
5.15	JFET current regulator	259
5.16	Differential amplifier	264
5.17	Simple op-amp	267
5.18	Audio oscillator	272
5.19	Vacuum tube audio amplifier	275
	Bibliography	286

6 ANALOG INTEGRATED CIRCUITS	287
6.1 Introduction	287
6.2 Voltage comparator	289
6.3 Precision voltage follower	292
6.4 Noninverting amplifier	296
6.5 High-impedance voltmeter	299
6.6 Integrator	303
6.7 555 audio oscillator	309
6.8 555 ramp generator	312
6.9 PWM power controller	315
6.10 Class B audio amplifier	319
7 DIGITAL INTEGRATED CIRCUITS	329
7.1 Introduction	329
7.2 Basic gate function	331
7.3 NOR gate S-R latch	335
7.4 NAND gate S-R enabled latch	339
7.5 NAND gate S-R flip-flop	341
7.6 555 Schmitt Trigger	345
7.7 LED sequencer	348
7.8 Simple combination lock	357
7.9 3-bit binary counter	360
7.10 7-segment display	362
A-1 ABOUT THIS BOOK	365
A-2 CONTRIBUTOR LIST	369
A-3 DESIGN SCIENCE LICENSE	373
INDEX	376

Chapter 1

INTRODUCTION

Contents

1.1 Electronics as science	1
1.2 Setting up a home lab	3
1.2.1 Work area	3
1.2.2 Tools	3
1.2.3 Supplies	10
1.3 Contributors	12

1.1 Electronics as science

Electronics is a science, and a very accessible science at that. With other areas of scientific study, expensive equipment is generally required to perform any non-trivial experiments. Not so with electronics. Many advanced concepts may be explored using parts and equipment totaling under a few hundred US dollars. This is good, because hands-on experimentation is vital to gaining scientific knowledge about any subject.

When I started writing *Lessons In Electric Circuits*, my intent was to create a textbook suitable for introductory college use. However, being mostly self-taught in electronics myself, I knew the value of a good textbook to hobbyists and experimenters not enrolled in any formal electronics course. Many people selflessly volunteered their time and expertise in helping me learn electronics when I was younger, and my intent is to honor their service and love by giving back to the world what they gave to me.

In order for someone to teach themselves a science such as electronics, they must engage in hands-on experimentation. Knowledge gleaned from books alone has limited use, especially in scientific endeavors. If my contribution to society is to be complete, I must include a guide to experimentation along with the text(s) on theory, so that the individual learning on their own has a resource to guide their experimental adventures.

A formal laboratory course for college electronics study requires an enormous amount of work to prepare, and usually must be based around specific parts and equipment so that the

experiments will be sufficiently detailed, with results sufficiently precise to allow for rigorous comparison between experimental and theoretical data. A process of assessment, articulated through a qualified instructor, is also vital to guarantee that a certain level of learning has taken place. Peer review (comparison of experimental results with the work of others) is another important component of college-level laboratory study, and helps to improve the quality of learning. Since I cannot meet these criteria through the medium of a book, it is impractical for me to present a complete laboratory course here. In the interest of keeping this experiment guide reasonably low-cost for people to follow, and practical for deployment over the internet, I am forced to design the experiments at a lower level than what would be expected for a college lab course.

The experiments in this volume begin at a level appropriate for someone with no electronics knowledge, and progress to higher levels. They stress qualitative knowledge over quantitative knowledge, although they could serve as templates for more rigorous coursework. If there is any portion of *Lessons In Electric Circuits* that will remain "incomplete," it is this one: I fully intend to continue adding experiments *ad infinitum* so as to provide the experimenter or hobbyist with a wealth of ideas to explore the science of electronics. This volume of the book series is also the easiest to contribute to, for those who would like to help me in providing free information to people learning electronics. It doesn't take a tremendous effort to describe an experiment or two, and I will gladly include it if you email it to me, giving you full credit for the work. Refer to Appendix 2 for details on contributing to this book.

When performing these experiments, feel free to explore by trying different circuit construction and measurement techniques. If something isn't working as the text describes it should, don't give up! It's probably due to a simple problem in construction (loose wire, wrong component value) or test equipment setup. It can be frustrating working through these problems on your own, but the knowledge gained by "troubleshooting" a circuit yourself is at least as important as the knowledge gained by a properly functioning experiment. This is one of the most important reasons why experimentation is so vital to your scientific education: the real problems you will invariably encounter in experimentation challenge you to develop practical problem-solving skills.

In many of these experiments, I offer part numbers for Radio Shack brand components. This is not an endorsement of Radio Shack, but simply a convenient reference to an electronic supply company well-known in North America. Often times, components of better quality and lower price may be obtained through mail-order companies and other, lesser-known supply houses. I strongly recommend that experimenters obtain some of the more expensive components such as transformers (see the AC chapter) by salvaging them from discarded electrical appliances, both for economic and ecological reasons.

All experiments shown in this book are designed with safety in mind. It is nearly impossible to shock or otherwise hurt yourself by battery-powered experiments or other circuits of low voltage. However, hazards *do* exist building anything with your own two hands. Where there is a greater-than-normal level of danger in an experiment, I take efforts to direct the reader's attention toward it. However, it is unfortunately necessary in this litigious society to disclaim any and all liability for the outcome of any experiment presented here. Neither myself nor any contributors bear responsibility for injuries resulting from the construction or use of any of these projects, from the mis-handling of electricity by the experimenter, or from any other unsafe practices leading to injury. **Perform these experiments at your own risk!**

1.2 Setting up a home lab

In order to build the circuits described in this volume, you will need a small work area, as well as a few tools and critical supplies. This section describes the setup of a home electronics laboratory.

1.2.1 Work area

A work area should consist of a large workbench, desk, or table (preferably wooden) for performing circuit assembly, with household electrical power (120 volts AC) readily accessible to power soldering equipment, power supplies, and any test equipment. Inexpensive desks intended for computer use function very well for this purpose. Avoid a metal-surface desk, as the electrical conductivity of a metal surface creates both a shock hazard and the very distinct possibility of unintentional "short circuits" developing from circuit components touching the metal tabletop. Vinyl and plastic bench surfaces are to be avoided for their ability to generate and store large static-electric charges, which may damage sensitive electronic components. Also, these materials melt easily when exposed to hot soldering irons and molten solder droplets.

If you cannot obtain a wooden-surface workbench, you may turn any form of table or desk into one by laying a piece of plywood on top. If you are reasonably skilled with woodworking tools, you may construct your own desk using plywood and 2x4 boards.

The work area should be well-lit and comfortable. I have a small radio set up on my own workbench for listening to music or news as I experiment. My own workbench has a "power strip" receptacle and switch assembly mounted to the underside, into which I plug all 120 volt devices. It is convenient to have a single switch for shutting off *all* power in case of an accidental short-circuit!

1.2.2 Tools

A few tools are required for basic electronics work. Most of these tools are inexpensive and easy to obtain. If you desire to keep the cost as low as possible, you might want to search for them at thrift stores and pawn shops before buying them new. As you can tell from the photographs, some of my own tools are rather old but function well nonetheless.

First and foremost in your tool collection is a multimeter. This is an electrical instrument designed to measure voltage, current, resistance, and often other variables as well. Multimeters are manufactured in both *digital* and *analog* form. A digital multimeter is preferred for precision work, but analog meters are also useful for gaining an intuitive understanding of instrument sensitivity and range.

My own digital multimeter is a Fluke model 27, purchased in 1987:

Digital multimeter



Most analog multimeters sold today are quite inexpensive, and not necessarily precision test instruments. I recommend having both digital and analog meter types in your tool collection, spending as little money as possible on the analog multimeter and investing in a good-quality digital multimeter (I highly recommend the Fluke brand).

=====

A test instrument I have found indispensable in my home work is a *sensitive voltage detector*, or *sensitive audio detector*, described in nearly identical experiments in two chapters of this book volume. It is nothing more than a sensitized set of audio headphones, equipped with an attenuator (volume control) and limiting diodes to limit sound intensity from strong signals. Its purpose is to audibly indicate the presence of low-intensity voltage signals, DC or AC. In the absence of an oscilloscope, this is a most valuable tool, because it allows you to *listen* to an electronic signal, and thereby determine something of its nature. Few tools engender an intuitive comprehension of frequency and amplitude as this! I cite its use in many of the experiments shown in this volume, so I strongly encourage that you build your own. Second only to a multimeter, it is the most useful piece of test equipment in the collection of the budget electronics experimenter.

Sensitive voltage/audio detector



As you can see, I built my detector using scrap parts (household electrical switch/receptacle box for the enclosure, section of brown lamp cord for the test leads). Even some of the internal components were salvaged from scrap (the step-down transformer and headphone jack were

taken from an old radio, purchased in non-working condition from a thrift store). The entire thing, including the headphones purchased second-hand, cost no more than \$15 to build. Of course, one could take much greater care in choosing construction materials (metal box, shielded test probe cable), but it probably wouldn't improve its performance significantly.

The single most influential component with regard to detector sensitivity is the headphone assembly: generally speaking, the greater the "dB" rating of the headphones, the better they will function for this purpose. Since the headphones need not be modified for use in the detector circuit, and they can be unplugged from it, you might justify the purchase of more expensive, high-quality headphones by using them as part of a home entertainment (audio/video) system.

=====

Also essential is a *solderless breadboard*, sometimes called a *prototyping board*, or *proto-board*. This device allows you to quickly join electronic components to one another without having to solder component terminals and wires together.

Solderless breadboard

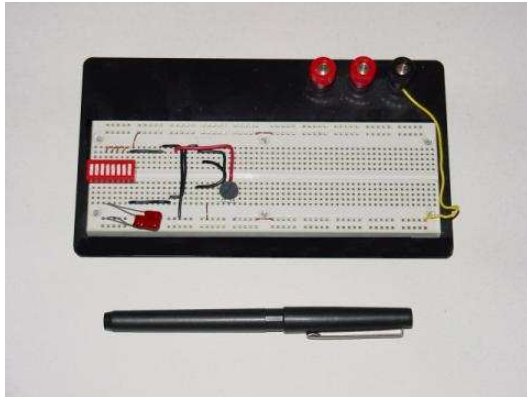

=====

When working with wire, you need a tool to "strip" the plastic insulation off the ends so that bare copper metal is exposed. This tool is called a *wire stripper*, and it is a special form of plier with several knife-edged holes in the jaw area sized just right for cutting through the plastic insulation and not the copper, for a multitude of wire sizes, or *gauges*. Shown here are two different sizes of wire stripping pliers:

Wire stripping pliers



=====

In order to make quick, temporary connections between some electronic components, you need *jumper wires* with small "alligator-jaw" clips at each end. These may be purchased complete, or assembled from clips and wires.

Jumper wires (as sold by Radio Shack)

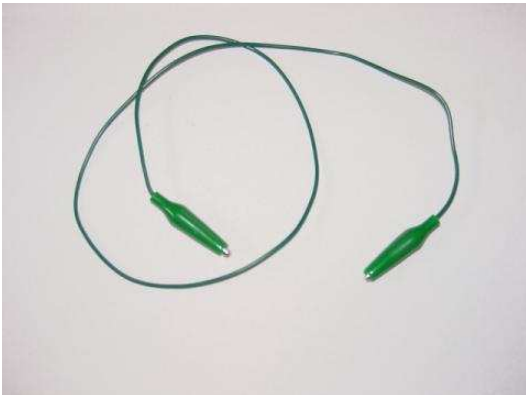

Jumper wires (home-made)



The home-made jumper wires with large, uninsulated (bare metal) alligator clips are okay

to use so long as care is taken to avoid any unintentional contact between the bare clips and any other wires or components. For use in crowded breadboard circuits, jumper wires with insulated (rubber-covered) clips like the jumper shown from Radio Shack are much preferred.

=====

Needle-nose pliers are designed to grasp small objects, and are especially useful for pushing wires into stubborn breadboard holes.

Needle-nose pliers



=====

No tool set would be complete without screwdrivers, and I recommend a complementary pair (3/16 inch slotted and #2 Phillips) as the starting point for your collection. You may later find it useful to invest in a set of *jeweler's screwdrivers* for work with very small screws and screw-head adjustments.

Screwdrivers

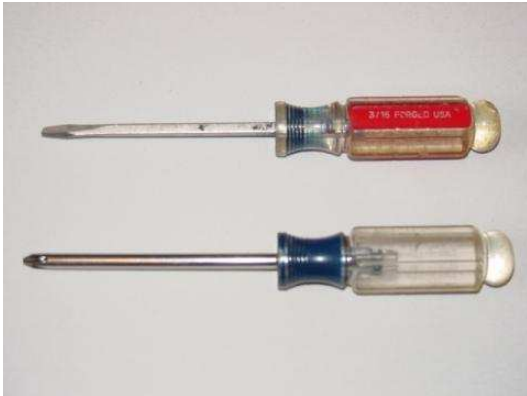

=====

For projects involving printed-circuit board assembly or repair, a small soldering iron and a spool of "rosin-core" solder are essential tools. I recommend a 25 watt soldering iron, no larger for printed circuit board work, and the thinnest solder you can find. *Do not use "acid-core" solder!* Acid-core solder is intended for the soldering of copper tubes (plumbing), where a small amount of acid helps to clean the copper of surface impurities and provide a stronger bond. If used for electrical work, the residual acid will cause wires to corrode. Also, you should avoid

solder containing the metal *lead*, opting instead for silver-alloy solder. If you do not already wear glasses, a pair of safety glasses is highly recommended while soldering, to prevent bits of molten solder from accidentally landing in your eye should a wire release from the joint during the soldering process and fling bits of solder toward you.

Soldering iron and solder ("rosin core")



=====
Projects requiring the joining of large wires by soldering will necessitate a more powerful heat source than a 25 watt soldering iron. A soldering *gun* is a practical option.

Soldering gun



=====
Knives, like screwdrivers, are essential tools for all kinds of work. For safety's sake, I recommend a "utility" knife with retracting blade. These knives are also advantageous to have for their ability to accept replacement blades.

Utility knife



=====

Pliers other than the needle-nose type are useful for the assembly and disassembly of electronic device chassis. Two types I recommend are *slip-joint* and *adjustable-joint* ("Channel-lock").

Slip-joint pliers



Adjustable-joint pliers



=====

Drilling may be required for the assembly of large projects. Although power drills work well, I have found that a simple hand-crank drill does a remarkable job drilling through plastic, wood, and most metals. It is certainly safer and quieter than a power drill, and costs quite a bit less.

Hand drill



As the wear on my drill indicates, it is an often-used tool around my home!

=====

Some experiments will require a source of audio-frequency voltage signals. Normally, this type of signal is generated in an electronics laboratory by a device called a *signal generator* or *function generator*. While building such a device is not impossible (nor difficult!), it often requires the use of an oscilloscope to fine-tune, and oscilloscopes are usually outside the budgetary range of the home experimenter. A relatively inexpensive alternative to a commercial signal generator is an *electronic keyboard* of the musical type. You need not be a musician to operate one for the purposes of generating an audio signal (just press any key on the board!), and they may be obtained quite readily at second-hand stores for substantially less than new price. The electronic signal generated by the keyboard is conducted to your circuit via a headphone cable plugged into the "headphones" jack. More details regarding the use of a "Musical Keyboard as a Signal Generator" may be found in the experiment of that name in chapter 4 (AC).

1.2.3 Supplies

Wire used in solderless breadboards must be 22-gauge, solid copper. Spools of this wire are available from electronic supply stores and some hardware stores, in different insulation colors. Insulation color has no bearing on the wire's performance, but different colors are sometimes useful for "color-coding" wire functions in a complex circuit.

Spool of 22-gauge, solid copper wire



Note how the last 1/4 inch or so of the copper wire protruding from the spool has been "stripped" of its plastic insulation.

=====

An alternative to solderless breadboard circuit construction is *wire-wrap*, where 30-gauge (very thin!) solid copper wire is tightly wrapped around the terminals of components inserted through the holes of a fiberglass board. No soldering is required, and the connections made are at least as durable as soldered connections, perhaps more. Wire-wrapping requires a spool of this very thin wire, and a special wrapping tool, the simplest kind resembling a small screwdriver.

Wire-wrap wire and wrapping tool

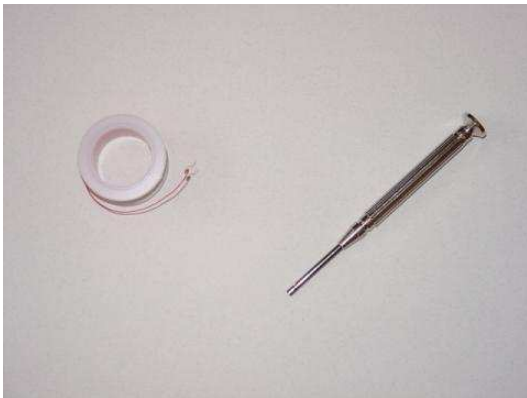

=====

Large wire (14 gauge and bigger) may be needed for building circuits that carry significant levels of current. Though electrical wire of practically any gauge may be purchased on spools, I have found a very inexpensive source of stranded (flexible), copper wire, available at any hardware store: cheap extension cords. Typically comprised of three wires colored white, black, and green, extension cords are often sold at prices less than the retail cost of the constituent wire alone. This is especially true if the cord is purchased on sale! Also, an extension cord provides you with a pair of 120 volt connectors: male (plug) and female (receptacle) that may be used for projects powered by 120 volts.

Extension cord, in package



To extract the wires, carefully cut the outer layer of plastic insulation away using a utility knife. With practice, you may find you can peel away the outer insulation by making a short cut in it at one end of the cable, then grasping the wires with one hand and the insulation with the other and pulling them apart. This is, of course, much preferable to slicing the entire length of the insulation with a knife, both for safety's sake and for the sake of avoiding cuts in the individual wires' insulation.

=====

During the course of building many circuits, you will accumulate a large number of small components. One technique for keeping these components organized is to keep them in a plastic "organizer" box like the type used for fishing tackle.

Component box



In this view of one of my component boxes, you can see plenty of 1/8 watt resistors, transistors, diodes, and even a few 8-pin integrated circuits ("chips"). Labels for each compartment were made with a permanent ink marker.

1.3 Contributors

Contributors to this chapter are listed in chronological order of their contributions, from most recent to first. See Appendix 2 (Contributor List) for dates and contact information.

Michael Warner (April 9, 2002): Suggestions for a section describing home laboratory setup.

Chapter 2

BASIC CONCEPTS AND TEST EQUIPMENT

Contents

2.1 Voltmeter usage	15
2.2 Ohmmeter usage	21
2.3 A very simple circuit	28
2.4 Ammeter usage	35
2.5 Ohm's Law	42
2.6 Nonlinear resistance	45
2.7 Power dissipation	48
2.8 Circuit with a switch	53
2.9 Electromagnetism	55
2.10 Electromagnetic induction	57

2.1 Voltmeter usage

PARTS AND MATERIALS

- Multimeter, digital or analog
- Assorted batteries
- One light-emitting diode (Radio Shack catalog # 276-026 or equivalent)
- Small "hobby" motor, permanent-magnet type (Radio Shack catalog # 273-223 or equivalent)

- Two jumper wires with "alligator clip" ends (Radio Shack catalog # 278-1156, 278-1157, or equivalent)

A *multimeter* is an electrical instrument capable of measuring voltage, current, and resistance. *Digital* multimeters have numerical displays, like digital clocks, for indicating the quantity of voltage, current, or resistance. *Analog* multimeters indicate these quantities by means of a moving pointer over a printed scale.

Analog multimeters tend to be less expensive than digital multimeters, and more beneficial as learning tools for the first-time student of electricity. I strongly recommend purchasing an analog multimeter before purchasing a digital multimeter, but to eventually have both in your tool kit for these experiments.

CROSS-REFERENCES

Lessons In Electric Circuits, Volume 1, chapter 1: "Basic Concepts of Electricity"

Lessons In Electric Circuits, Volume 1, chapter 8: "DC Metering Circuits"

LEARNING OBJECTIVES

- How to measure voltage
- Characteristics of voltage: existing *between two points*
- Selection of proper meter range

ILLUSTRATION

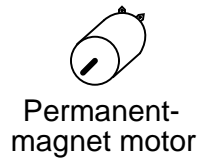
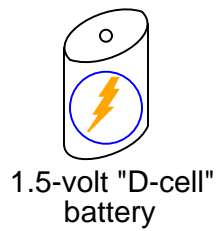
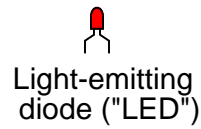
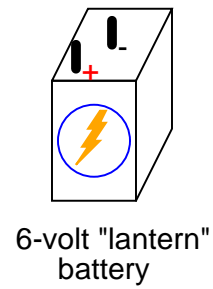
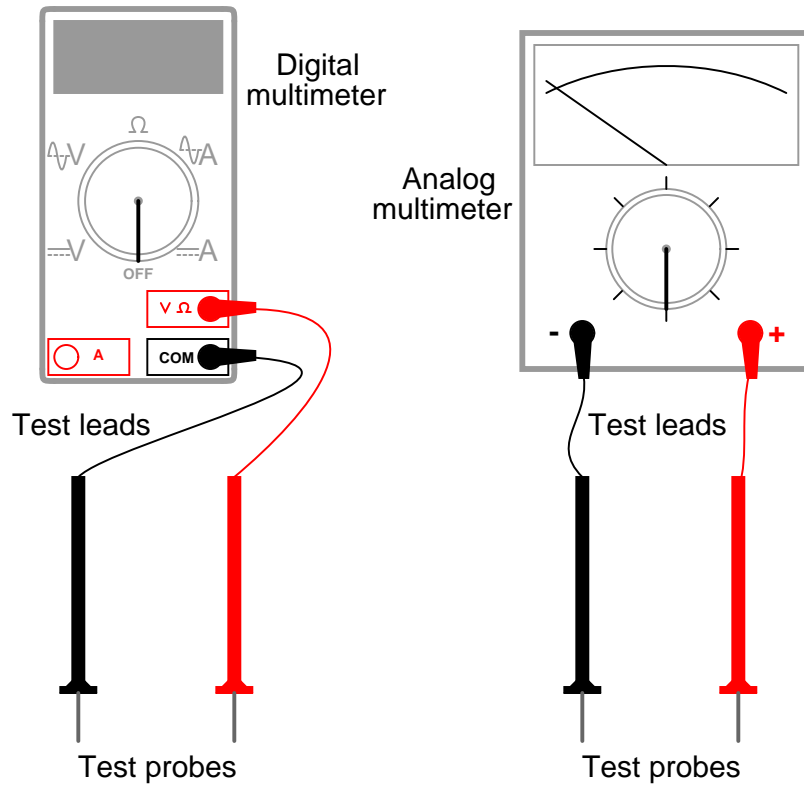

INSTRUCTIONS

In all the experiments in this book, you will be using some sort of test equipment to measure aspects of electricity you cannot directly see, feel, hear, taste, or smell. Electricity – at least in small, safe quantities – is insensible by our human bodies. Your most fundamental “eyes” in the world of electricity and electronics will be a device called a *multimeter*. Multimeters indicate the presence of, and measure the quantity of, electrical properties such as *voltage*, *current*, and *resistance*. In this experiment, you will familiarize yourself with the measurement of voltage.

Voltage is the measure of electrical “push” ready to motivate electrons to move through a conductor. In scientific terms, it is the specific energy per unit charge, mathematically defined as joules per coulomb. It is analogous to *pressure* in a fluid system: the force that moves fluid through a pipe, and is measured in the unit of the Volt (V).

Your multimeter should come with some basic instructions. Read them well! If your multimeter is digital, it will require a small battery to operate. If it is analog, it does not need a battery to measure voltage.

Some digital multimeters are *autoranging*. An autoranging meter has only a few selector switch (dial) positions. Manual-ranging meters have several different selector positions for each basic quantity: several for voltage, several for current, and several for resistance. Autoranging is usually found on only the more expensive digital meters, and is to manual ranging as an automatic transmission is to a manual transmission in a car. An autoranging meter “shifts gears” automatically to find the best measurement range to display the particular quantity being measured.

Set your multimeter’s selector switch to the highest-value “DC volt” position available. Autoranging multimeters may only have a single position for DC voltage, in which case you need to set the switch to that one position. Touch the red test probe to the positive (+) side of a battery, and the black test probe to the negative (-) side of the same battery. The meter should now provide you with some sort of indication. Reverse the test probe connections to the battery if the meter’s indication is negative (on an analog meter, a negative value is indicated by the pointer deflecting left instead of right).

If your meter is a manual-range type, and the selector switch has been set to a high-range position, the indication will be small. Move the selector switch to the next lower DC voltage range setting and reconnect to the battery. The indication should be stronger now, as indicated by a greater deflection of the analog meter pointer (*needle*), or more active digits on the digital meter display. For the best results, move the selector switch to the lowest-range setting that does not “over-range” the meter. An over-ranged analog meter is said to be “pegged,” as the needle will be forced all the way to the right-hand side of the scale, past the full-range scale value. An over-ranged digital meter sometimes displays the letters “OL”, or a series of dashed lines. This indication is manufacturer-specific.

What happens if you only touch one meter test probe to one end of a battery? How does the meter have to connect to the battery in order to provide an indication? What does this tell us about voltmeter use and the nature of voltage? Is there such a thing as voltage “at” a single point?

Be sure to measure more than one size of battery, and learn how to select the best voltage range on the multimeter to give you maximum indication without over-ranging.

Now switch your multimeter to the lowest DC voltage range available, and touch the meter’s test probes to the terminals (wire leads) of the light-emitting diode (LED). An LED is designed to produce light when powered by a small amount of electricity, but LEDs also happen to *generate* DC voltage when exposed to light, somewhat like a solar cell. Point the LED toward

a bright source of light with your multimeter connected to it, and note the meter's indication:

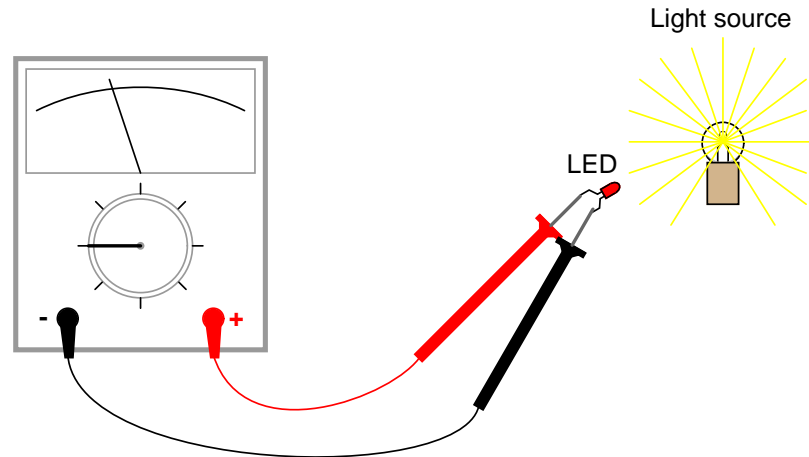

Batteries develop electrical voltage through chemical reactions. When a battery "dies," it has exhausted its original store of chemical "fuel." The LED, however, does not rely on an internal "fuel" to generate voltage; rather, it *converts* optical energy into electrical energy. So long as there is light to illuminate the LED, it will produce voltage.

Another source of voltage through energy conversion is a *generator*. The small electric motor specified in the "Parts and Materials" list functions as an electrical generator if its shaft is turned by a mechanical force. Connect your voltmeter (your multimeter, set to the "volt" function) to the motor's terminals just as you connected it to the LED's terminals, and spin the shaft with your fingers. The meter should indicate voltage by means of needle deflection (analog) or numerical readout (digital).

If you find it difficult to maintain both meter test probes in connection with the motor's terminals while simultaneously spinning the shaft with your fingers, you may use *alligator clip* "jumper" wires like this:

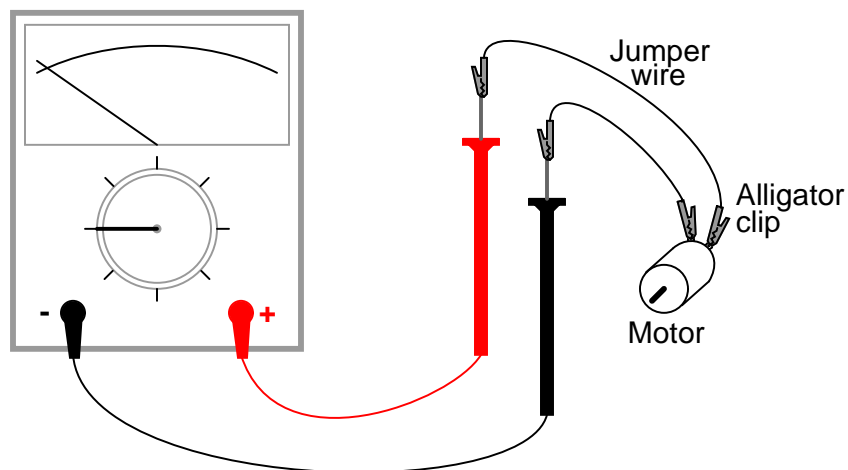

Determine the relationship between voltage and generator shaft speed? Reverse the generator's direction of rotation and note the change in meter indication. When you reverse shaft rotation, you change the *polarity* of the voltage created by the generator. The voltmeter indicates polarity by *direction* of needle direction (analog) or *sign* of numerical indication (digital). When the red test lead is positive (+) and the black test lead negative (-), the meter will register voltage in the normal direction. If the applied voltage is of the reverse polarity (negative on red and positive on black), the meter will indicate "backwards."

2.2 Ohmmeter usage

PARTS AND MATERIALS

- Multimeter, digital or analog
- Assorted resistors (Radio Shack catalog # 271-312 is a 500-piece assortment)
- Rectifying diode (1N4001 or equivalent; Radio Shack catalog # 276-1101)
- Cadmium Sulphide photocell (Radio Shack catalog # 276-1657)
- Breadboard (Radio Shack catalog # 276-174 or equivalent)
- Jumper wires
- Paper
- Pencil
- Glass of water
- Table salt

This experiment describes how to measure the electrical resistance of several objects. You need not possess *all* items listed above in order to effectively learn about resistance. Conversely, you need not limit your experiments to these items. However, be sure to **never** measure the resistance of any electrically "live" object or circuit. In other words, do not attempt to measure the resistance of a battery or any other source of substantial voltage using a multimeter set to the resistance ("ohms") function. Failing to heed this warning will likely result in meter damage and even personal injury.

CROSS-REFERENCES

Lessons In Electric Circuits, Volume 1, chapter 1: "Basic Concepts of Electricity"
Lessons In Electric Circuits, Volume 1, chapter 8: "DC Metering Circuits"

LEARNING OBJECTIVES

- Determination and comprehension of "electrical continuity"
- Determination and comprehension of "electrically common points"
- How to measure resistance
- Characteristics of resistance: existing *between two points*
- Selection of proper meter range
- Relative conductivity of various components and materials

ILLUSTRATION

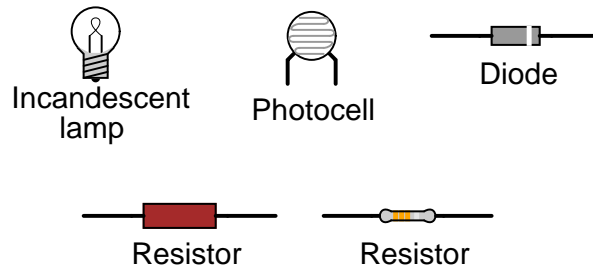

INSTRUCTIONS

Resistance is the measure of electrical "friction" as electrons move through a conductor. It is measured in the unit of the "Ohm," that unit symbolized by the capital Greek letter omega (Ω).

Set your multimeter to the highest resistance range available. The resistance function is usually denoted by the unit symbol for resistance: the Greek letter omega (Ω), or sometimes by the word "ohms." Touch the two test probes of your meter together. When you do, the meter should register 0 ohms of resistance. If you are using an analog meter, you will notice the needle deflect full-scale when the probes are touched together, and return to its resting position when the probes are pulled apart. The resistance scale on an analog multimeter is reverse-printed from the other scales: zero resistance is indicated at the far right-hand side of the scale, and infinite resistance is indicated at the far left-hand side. There should also be a small adjustment knob or "wheel" on the analog multimeter to calibrate it for "zero" ohms of resistance. Touch the test probes together and move this adjustment until the needle exactly points to zero at the right-hand end of the scale.

Although your multimeter is capable of providing quantitative values of measured resistance, it is also useful for *qualitative tests of continuity*: whether or not there is a continuous electrical connection from one point to another. You can, for instance, test the continuity of a piece of wire by connecting the meter probes to opposite ends of the wire and checking to see the the needle moves full-scale. What would we say about a piece of wire if the ohmmeter needle didn't move at all when the probes were connected to opposite ends?

Digital multimeters set to the "resistance" mode indicate non-continuity by displaying some non-numerical indication on the display. Some models say "OL" (Open-Loop), while others display dashed lines.

Use your meter to determine continuity between the holes on a *breadboard*: a device used for temporary construction of circuits, where component terminals are inserted into holes on a plastic grid, metal spring clips underneath each hole connecting certain holes to others. Use small pieces of 22-gauge solid copper wire, inserted into the holes of the breadboard, to connect the meter to these spring clips so that you can test for continuity:

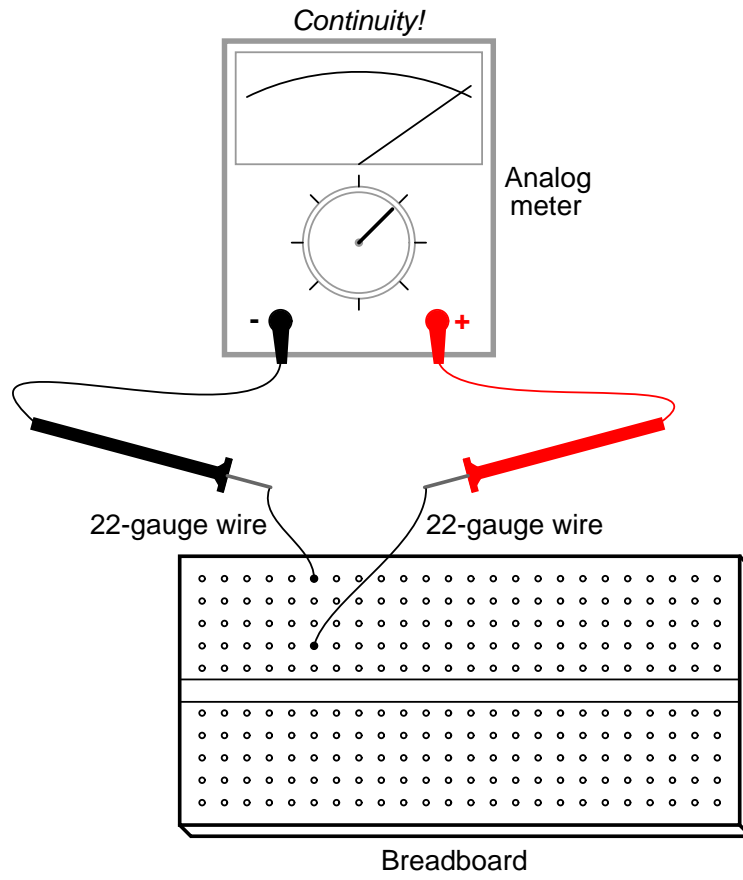

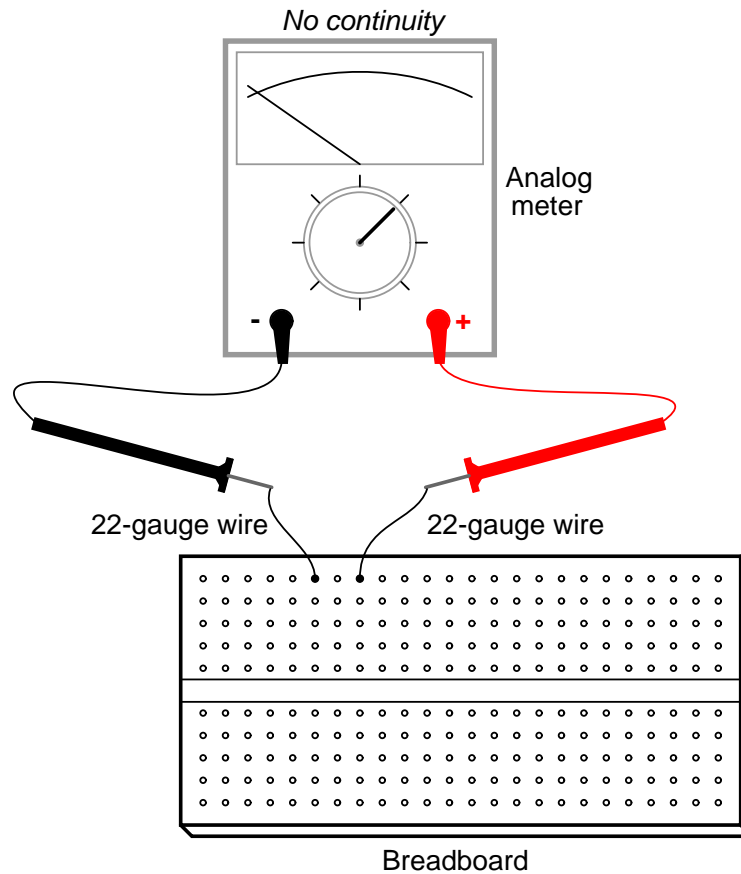

An important concept in electricity, closely related to electrical continuity, is that of points being *electrically common* to each other. Electrically common points are points of contact on a device or in a circuit that have negligible (extremely small) resistance between them. We could say, then, that points within a breadboard column (vertical in the illustrations) are *electrically common* to each other, because there is electrical *continuity* between them. Conversely, breadboard points within a row (horizontal in the illustrations) are not electrically common, because there is no continuity between them. *Continuity* describes what is between points of contact, while *commonality* describes how the points themselves relate to each other.

Like continuity, commonality is a qualitative assessment, based on a relative comparison of resistance between other points in a circuit. It is an important concept to grasp, because there are certain facts regarding voltage in relation to electrically common points that are valuable in circuit analysis and troubleshooting, the first one being that there will never be substantial voltage dropped between points that are electrically common to each other.

Select a 10,000 ohm (10 k Ω) resistor from your parts assortment. This resistance value is indicated by a series of color bands: Brown, Black, Orange, and then another color representing the precision of the resistor, Gold (+/- 5%) or Silver (+/- 10%). Some resistors have no color for precision, which marks them as +/- 20%. Other resistors use five color bands to denote their value and precision, in which case the colors for a 10 k Ω resistor will be Brown, Black, Black,

Red, and a fifth color for precision.

Connect the meter's test probes across the resistor as such, and note its indication on the resistance scale:

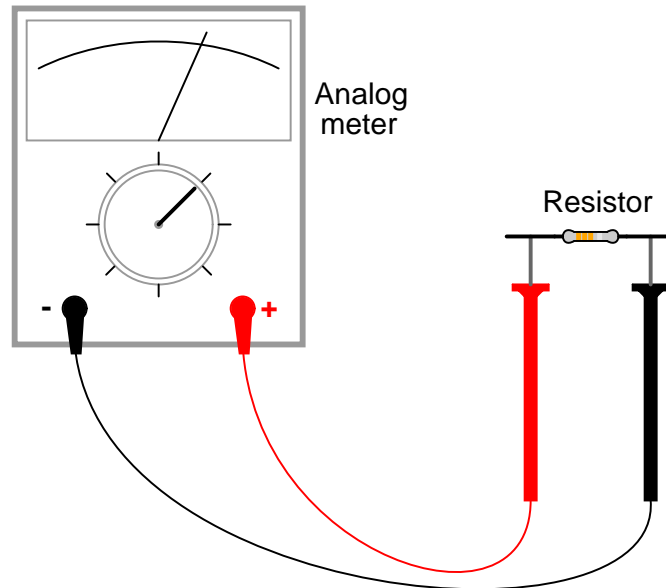

If the needle points very close to zero, you need to select a lower resistance range on the meter, just as you needed to select an appropriate voltage range when reading the voltage of a battery.

If you are using a digital multimeter, you should see a numerical figure close to 10 shown on the display, with a small "k" symbol on the right-hand side denoting the metric prefix for "kilo" (thousand). Some digital meters are manually-ranged, and require appropriate range selection just as the analog meter. If yours is like this, experiment with different range switch positions and see which one gives you the best indication.

Try reversing the test probe connections on the resistor. Does this change the meter's indication at all? What does this tell us about the resistance of a resistor? What happens when you only touch one probe to the resistor? What does this tell us about the nature of resistance, and how it is measured? How does this compare with voltage measurement, and what happened when we tried to measure battery voltage by touching only one probe to the battery?

When you touch the meter probes to the resistor terminals, try not to touch both probe tips to your fingers. If you do, you will be measuring the parallel combination of the resistor and your own body, which will tend to make the meter indication lower than it should be! When measuring a 10 k Ω resistor, this error will be minimal, but it may be more severe when measuring other values of resistor.

You may safely measure the resistance of your own body by holding one probe tip with the fingers of one hand, and the other probe tip with the fingers of the other hand. **Note:** be very careful with the probes, as they are often sharpened to a needle-point. Hold the probe tips along their length, not at the very points! You may need to adjust the meter range again after measuring the 10 k Ω resistor, as your body resistance tends to be greater than 10,000

ohms hand-to-hand. Try wetting your fingers with water and re-measuring resistance with the meter. What impact does this have on the indication? Try wetting your fingers with *salt* water prepared using the glass of water and table salt, and re-measuring resistance. What impact does this have on your body's resistance as measured by the meter?

Resistance is the measure of friction to electron flow through an object. The less resistance there is between two points, the harder it is for electrons to move (flow) between those two points. Given that electric shock is caused by a large flow of electrons through a person's body, and increased body resistance acts as a safeguard by making it more difficult for electrons to flow through us, what can we ascertain about electrical safety from the resistance readings obtained with wet fingers? Does water increase or decrease shock hazard to people?

Measure the resistance of a rectifying diode with an analog meter. Try reversing the test probe connections to the diode and re-measure resistance. What strikes you as being remarkable about the diode, especially in contrast to the resistor?

Take a piece of paper and draw a very heavy black mark on it with a pencil (not a pen!). Measure resistance on the black strip with your meter, placing the probe tips at each end of the mark like this:

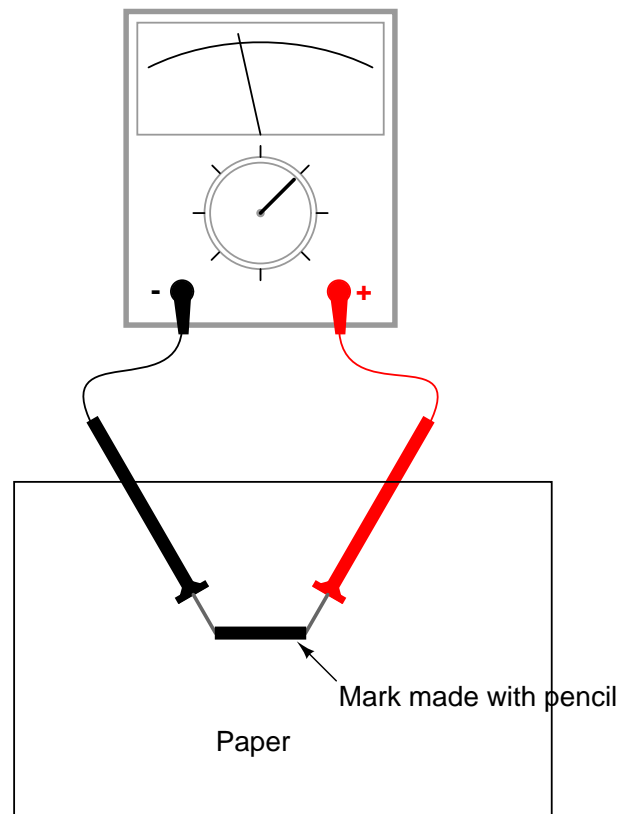

Move the probe tips closer together on the black mark and note the change in resistance value. Does it increase or decrease with decreased probe spacing? If the results are inconsistent, you need to redraw the mark with more and heavier pencil strokes, so that it is consistent

in its density. What does this teach you about resistance versus length of a conductive material?

Connect your meter to the terminals of a cadmium-sulphide (CdS) photocell and measure the change in resistance created by differences in light exposure. Just as with the light-emitting diode (LED) of the voltmeter experiment, you may want to use alligator-clip jumper wires to make connection with the component, leaving your hands free to hold the photocell to a light source and/or change meter ranges:

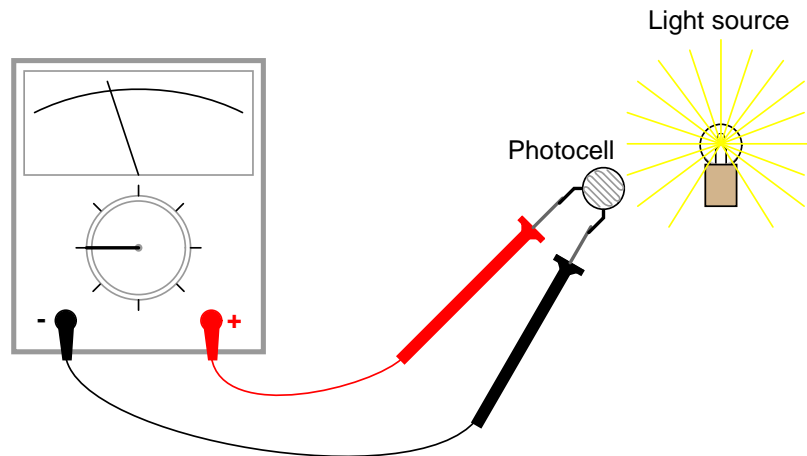

Experiment with measuring the resistance of several different types of materials, just be sure not to try measure anything that produces substantial voltage, like a battery. Suggestions for materials to measure are: fabric, plastic, wood, metal, clean water, dirty water, salt water, glass, diamond (on a diamond ring or other piece of jewelry), paper, rubber, and oil.

2.3 A very simple circuit

PARTS AND MATERIALS

- 6-volt battery
- 6-volt incandescent lamp
- Jumper wires
- Breadboard
- Terminal strip

From this experiment on, a multimeter is assumed to be necessary and will not be included in the required list of parts and materials. In all subsequent illustrations, a digital multimeter will be shown instead of an analog meter unless there is some particular reason to use an analog meter. You are encouraged to use *both* types of meters to gain familiarity with the operation of each in these experiments.

CROSS-REFERENCES

Lessons In Electric Circuits, Volume 1, chapter 1: "Basic Concepts of Electricity"

LEARNING OBJECTIVES

- Essential configuration needed to make a circuit
- Normal voltage drops in an operating circuit
- Importance of continuity to a circuit
- Working definitions of "open" and "short" circuits
- Breadboard usage
- Terminal strip usage

SCHEMATIC DIAGRAM

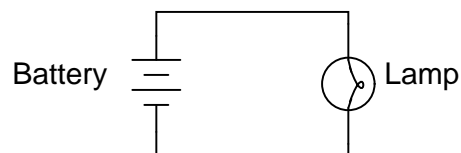

ILLUSTRATION

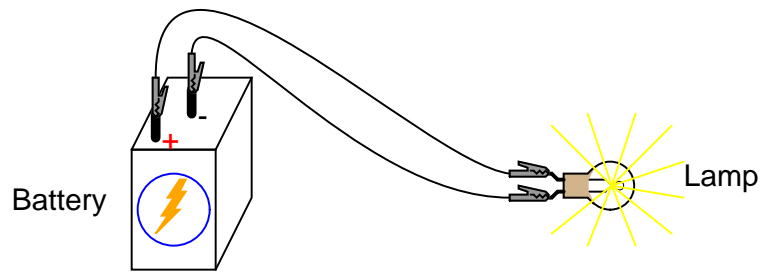

INSTRUCTIONS

This is the simplest complete circuit in this collection of experiments: a battery and an incandescent lamp. Connect the lamp to the battery as shown in the illustration, and the lamp should light, assuming the battery and lamp are both in good condition and they are matched to one another in terms of voltage.

If there is a "break" (discontinuity) anywhere in the circuit, the lamp will fail to light. It does *not* matter where such a break occurs! Many students assume that because electrons leave the negative (-) side of the battery and continue through the circuit to the positive (+) side, that the wire connecting the negative terminal of the battery to the lamp is more important to circuit operation than the other wire providing a return path for electrons back to the battery. This is not true!

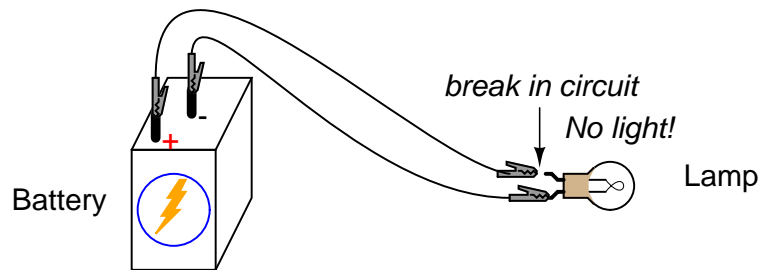
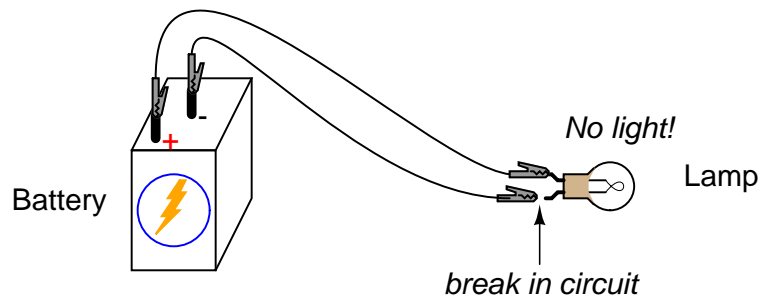

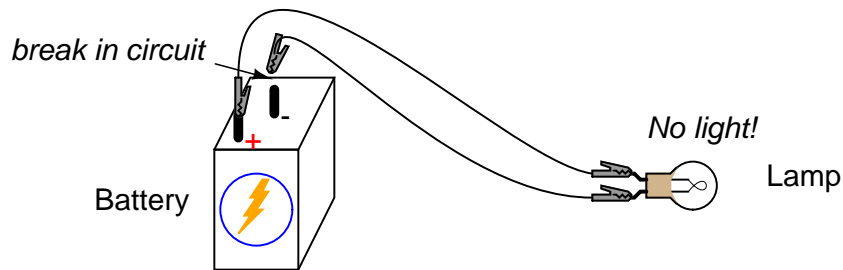
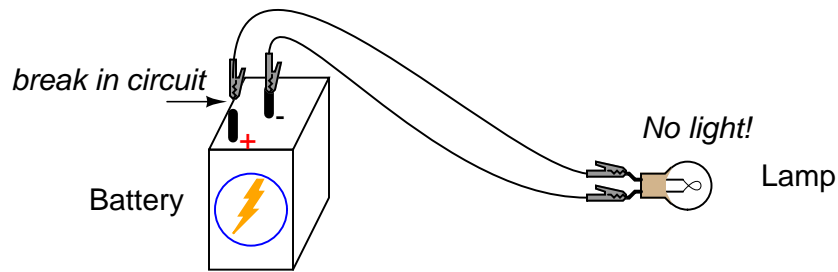

Using your multimeter set to the appropriate "DC volt" range, measure voltage across the battery, across the lamp, and across each jumper wire. Familiarize yourself with the normal voltages in a functioning circuit.

Now, "break" the circuit at one point and re-measure voltage between the same sets of points, additionally measuring voltage across the break like this:

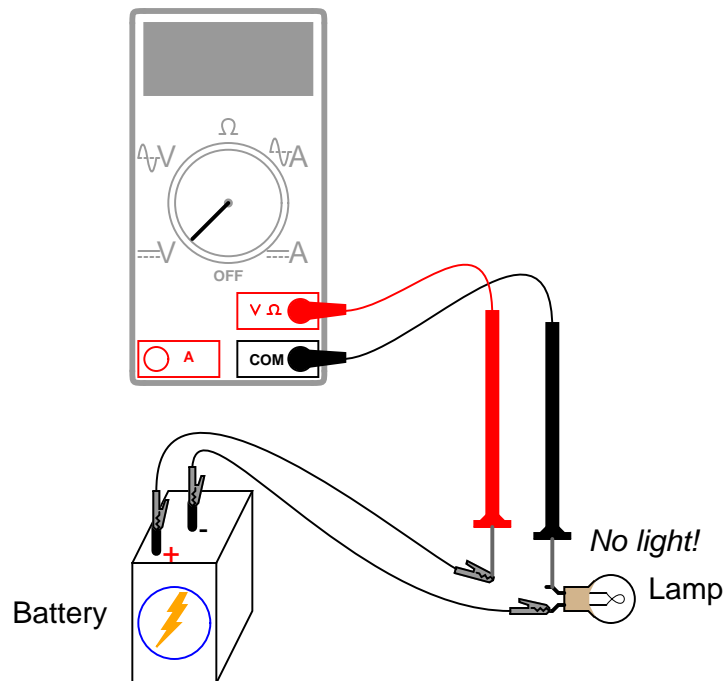

What voltages measure the same as before? What voltages are different since introducing the break? How much voltage is manifest, or *dropped* across the break? What is the *polarity* of the voltage drop across the break, as indicated by the meter?

Re-connect the jumper wire to the lamp, and break the circuit in another place. Measure all voltage "drops" again, familiarizing yourself with the voltages of an "open" circuit.

Construct the same circuit on a breadboard, taking care to place the lamp and wires into the breadboard in such a way that continuity will be maintained. The example shown here is only that: an example, not the *only* way to build a circuit on a breadboard:

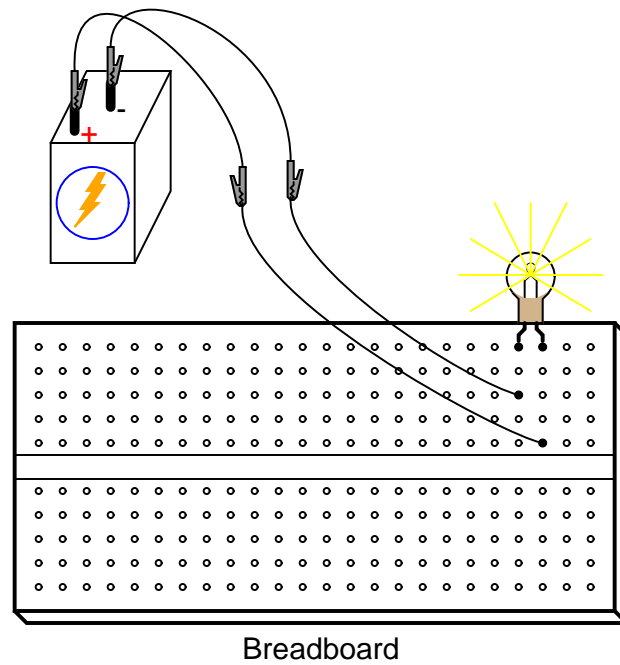

Experiment with different configurations on the breadboard, plugging the lamp into different holes. If you encounter a situation where the lamp refuses to light up and the connecting wires are getting warm, you probably have a situation known as a *short circuit*, where a lower-resistance path than the lamp bypasses current around the lamp, preventing enough voltage from being dropped across the lamp to light it up. Here is an example of a short circuit made on a breadboard:

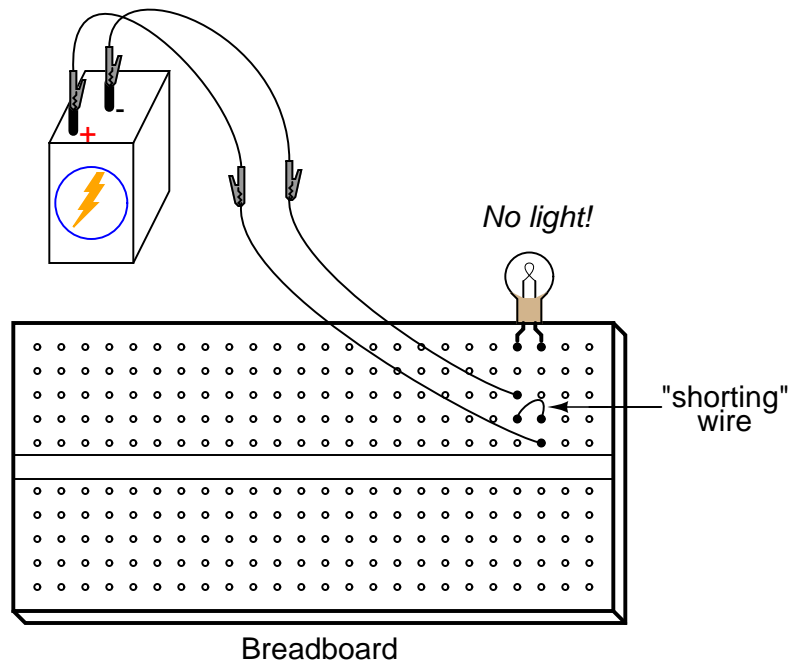

Here is an example of an *accidental* short circuit of the type typically made by students unfamiliar with breadboard usage:

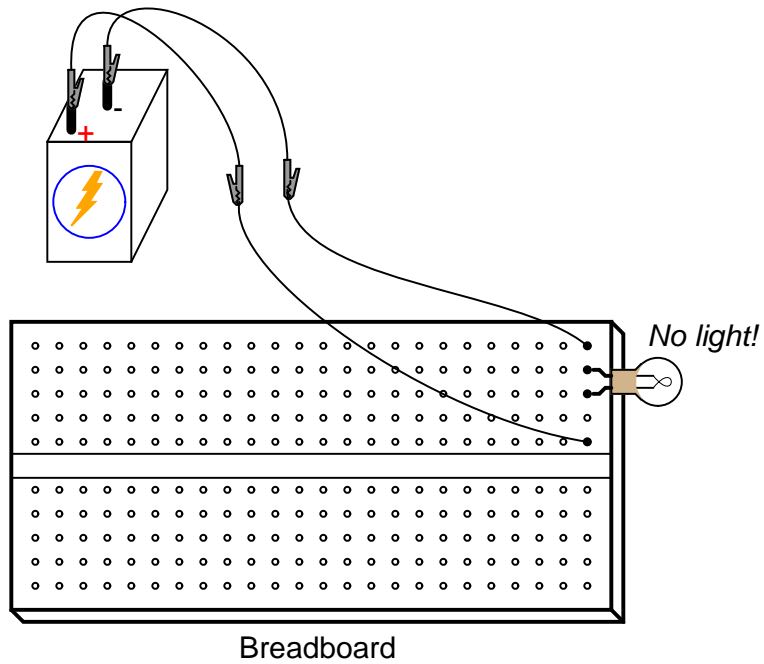

Here there is no "shorting" wire present on the breadboard, yet there *is* a short circuit, and the lamp refuses to light. Based on your understanding of breadboard hole connections, can you determine where the "short" is in this circuit?

Short circuits are generally to be avoided, as they result in very high rates of electron flow, causing wires to heat up and battery power sources to deplete. If the power source is substantial enough, a short circuit may cause heat of explosive proportions to manifest, causing equipment damage and hazard to nearby personnel. This is what happens when a tree limb "shorts" across wires on a power line: the limb – being composed of wet wood – acts as a low-resistance path to electric current, resulting in heat and sparks.

You may also build the battery/lamp circuit on a terminal strip: a length of insulating material with metal bars and screws to attach wires and component terminals to. Here is an example of how this circuit might be constructed on a terminal strip:

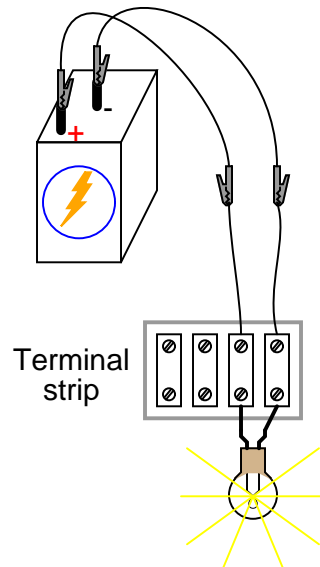

2.4 Ammeter usage

PARTS AND MATERIALS

- 6-volt battery
- 6-volt incandescent lamp

Basic circuit construction components such as breadboard, terminal strip, and jumper wires are also assumed to be available from now on, leaving only components and materials unique to the project listed under "Parts and Materials."

CROSS-REFERENCES

Lessons In Electric Circuits, Volume 1, chapter 1: "Basic Concepts of Electricity"

Lessons In Electric Circuits, Volume 1, chapter 8: "DC Metering Circuits"

LEARNING OBJECTIVES

- How to measure current with a multimeter
- How to check a multimeter's internal fuse
- Selection of proper meter range

SCHEMATIC DIAGRAM

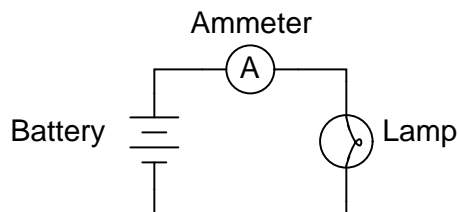

ILLUSTRATION

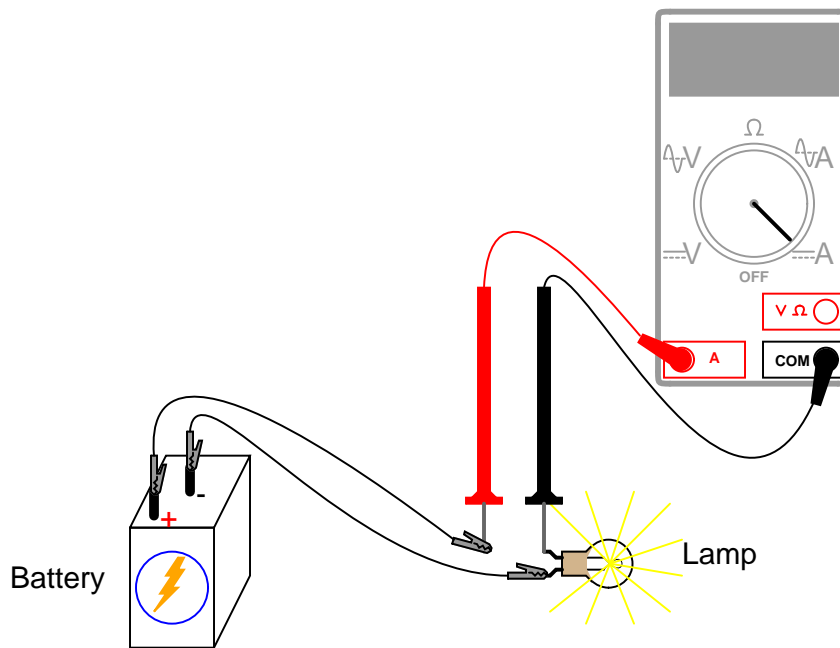

INSTRUCTIONS

Current is the measure of the rate of electron "flow" in a circuit. It is measured in the unit of the Ampere, simply called "Amp," (A).

The most common way to measure current in a circuit is to break the circuit open and insert an "ammeter" in *series* (in-line) with the circuit so that all electrons flowing through the circuit also have to go through the meter. Because measuring current in this manner requires the meter be made part of the circuit, it is a more difficult type of measurement to make than either voltage or resistance.

Some digital meters, like the unit shown in the illustration, have a separate jack to insert the red test lead plug when measuring current. Other meters, like most inexpensive analog meters, use the same jacks for measuring voltage, resistance, and current. Consult your owner's manual on the particular model of meter you own for details on measuring current.

When an ammeter is placed in series with a circuit, it ideally drops no voltage as current goes through it. In other words, it acts very much like a piece of wire, with very little resistance from one test probe to the other. Consequently, an ammeter will act as a short circuit if placed in parallel (across the terminals of) a substantial source of voltage. If this is done, a surge in current will result, potentially damaging the meter:

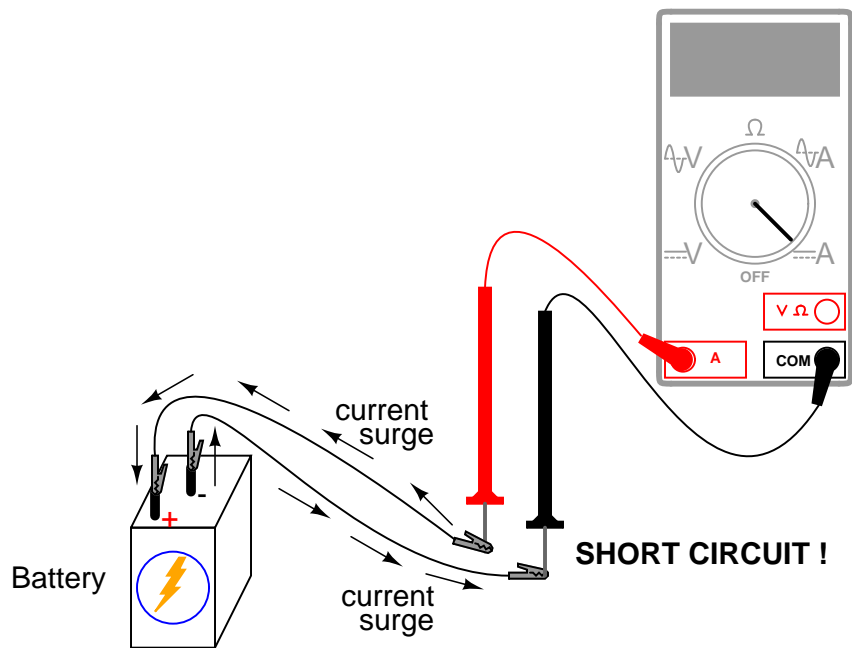

Ammeters are generally protected from excessive current by means of a small *fuse* located inside the meter housing. If the ammeter is accidentally connected across a substantial voltage source, the resultant surge in current will "blow" the fuse and render the meter incapable of measuring current until the fuse is replaced. **Be very careful to avoid this scenario!**

You may test the condition of a multimeter's fuse by switching it to the resistance mode and measuring continuity through the test leads (and through the fuse). On a meter where the same test lead jacks are used for both resistance and current measurement, simply leave the test lead plugs where they are and touch the two probes together. On a meter where different jacks are used, this is how you insert the test lead plugs to check the fuse:

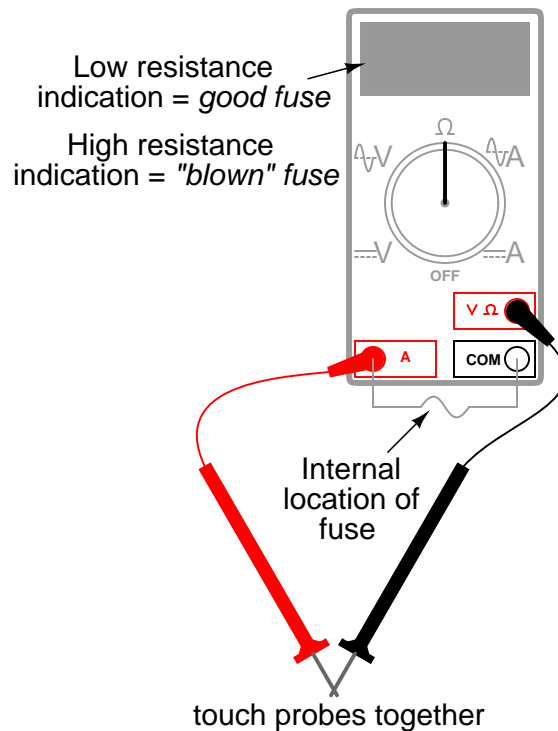

Build the one-battery, one-lamp circuit using jumper wires to connect the battery to the lamp, and verify that the lamp lights up before connecting the meter in series with it. Then, break the circuit open at any point and connect the meter's test probes to the two points of the break to measure current. As usual, if your meter is manually-ranged, begin by selecting the highest range for current, then move the selector switch to lower range positions until the strongest indication is obtained on the meter display without over-ranging it. If the meter indication is "backwards," (left motion on analog needle, or negative reading on a digital display), then reverse the test probe connections and try again. When the ammeter indicates a normal reading (not "backwards"), electrons are entering the black test lead and exiting the red. This is how you determine direction of current using a meter.

For a 6-volt battery and a small lamp, the circuit current will be in the range of *thousandths* of an amp, or *milliamps*. Digital meters often show a small letter "m" in the right-hand side of the display to indicate this metric prefix.

Try breaking the circuit at some other point and inserting the meter there instead. What do you notice about the amount of current measured? Why do you think this is?

Re-construct the circuit on a breadboard like this:

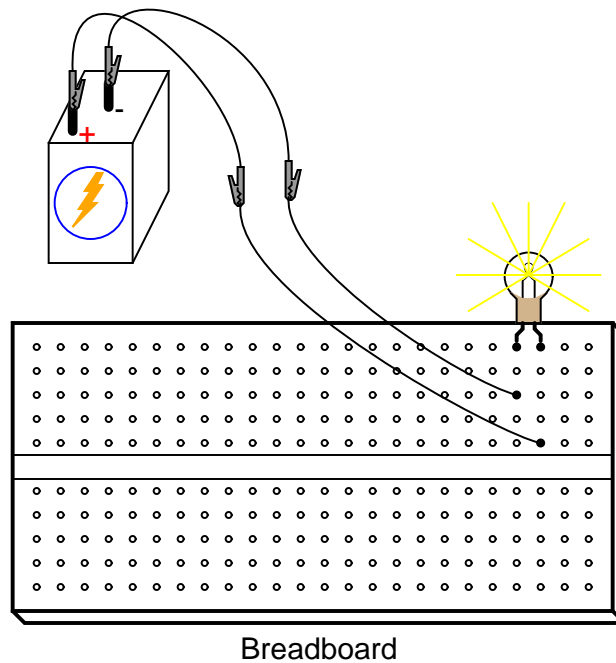

Students often get confused when connecting an ammeter to a breadboard circuit. How can the meter be connected so as to intercept all the circuit's current and not create a short circuit? One easy method that guarantees success is this:

- Identify what wire or component terminal you wish to measure current through.
- Pull that wire or terminal out of the breadboard hole. Leave it hanging in mid-air.
- Insert a spare piece of wire into the hole you just pulled the other wire or terminal out of. Leave the other end of this wire hanging in mid-air.
- Connect the ammeter between the two unconnected wire ends (the two that were hanging in mid-air). You are now *assured* of measuring current through the wire or terminal initially identified.

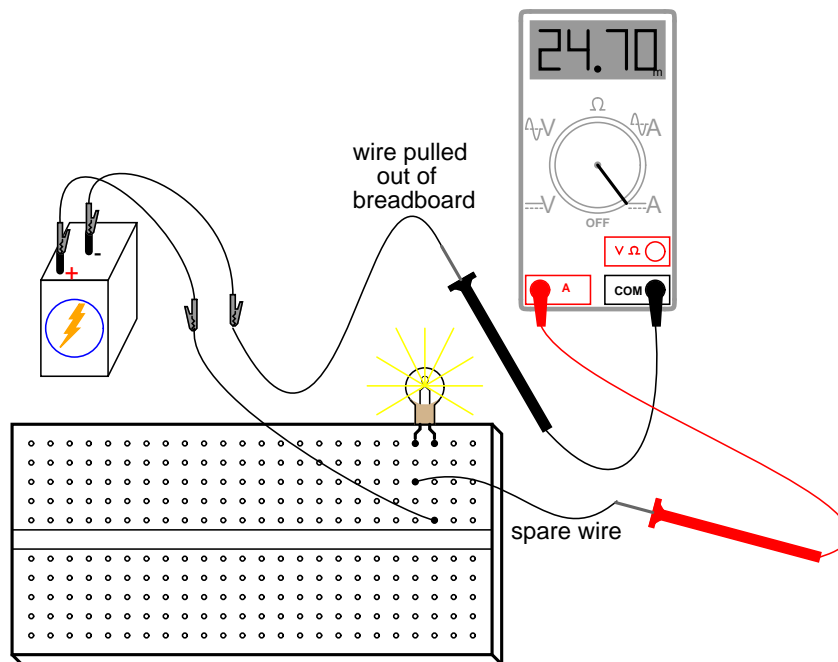

Again, measure current through different wires in this circuit, following the same connection procedure outlined above. What do you notice about these current measurements? The results in the breadboard circuit should be the same as the results in the free-form (no breadboard) circuit.

Building the same circuit on a terminal strip should also yield similar results:

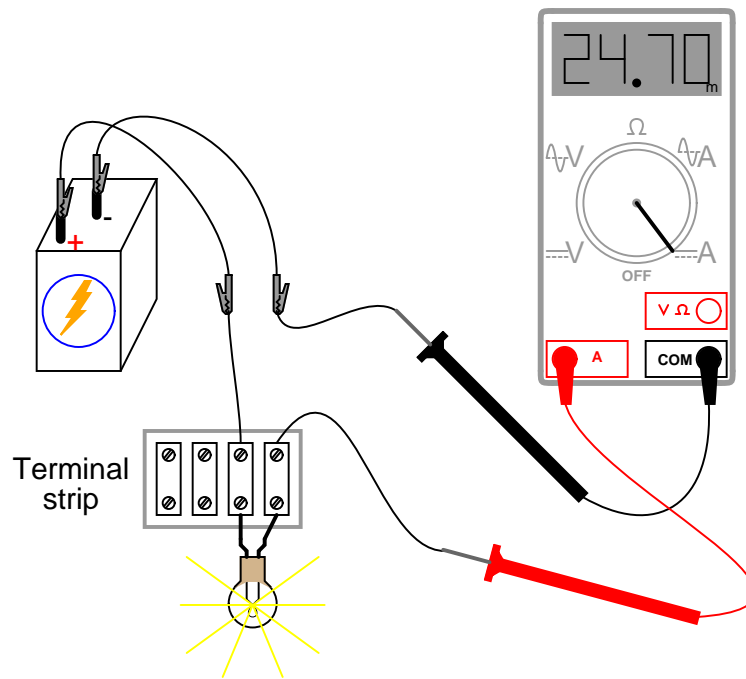

The current figure of 24.70 milliamps (24.70 mA) shown in the illustrations is an arbitrary quantity, reasonable for a small incandescent lamp. If the current for your circuit is a different value, that is okay, so long as the lamp is functioning when the meter is connected. If the lamp refuses to light when the meter is connected to the circuit, and the meter registers a much greater reading, you probably have a short-circuit condition through the meter. If your lamp refuses to light when the meter is connected in the circuit, and the meter registers zero current, you've probably blown the fuse inside the meter. Check the condition of your meter's fuse as described previously in this section and replace the fuse if necessary.

2.5 Ohm's Law

PARTS AND MATERIALS

- Calculator (or pencil and paper for doing arithmetic)
- 6-volt battery
- Assortment of resistors between 1 K Ω and 100 k Ω in value

I'm purposely restricting the resistance values between 1 k Ω and 100 k Ω for the sake of obtaining accurate voltage and current readings with your meter. With very low resistance values, the internal resistance of the ammeter has a significant impact on measurement accuracy. Very high resistance values can cause problems for voltage measurement, the internal resistance of the voltmeter substantially changing circuit resistance when it is connected in parallel with a high-value resistor.

At the recommended resistance values, there will still be a small amount of measurement error due to the "impact" of the meter, but not enough to cause serious disagreement with calculated values.

CROSS-REFERENCES

Lessons In Electric Circuits, Volume 1, chapter 2: "Ohm's Law"

LEARNING OBJECTIVES

- Voltmeter use
- Ammeter use
- Ohmmeter use
- Use of Ohm's Law

SCHEMATIC DIAGRAM

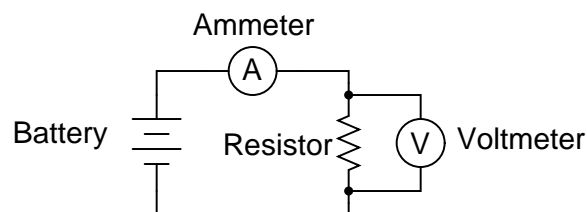

ILLUSTRATION

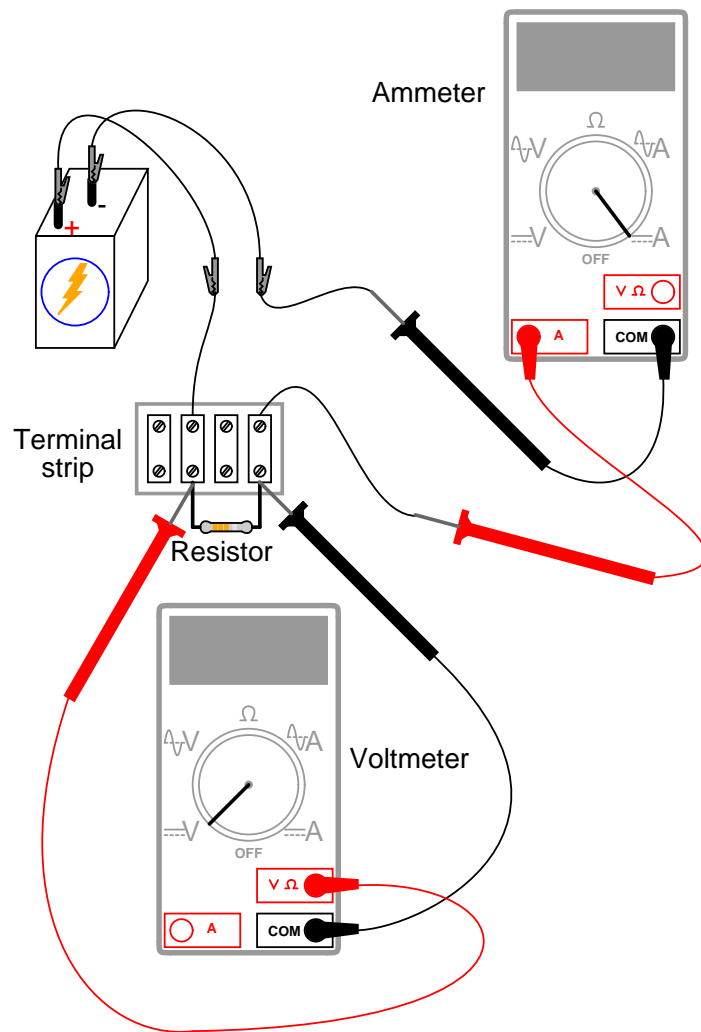

INSTRUCTIONS

Select a resistor from the assortment, and measure its resistance with your multimeter set to the appropriate resistance range. Be sure not to hold the resistor terminals when measuring resistance, or else your hand-to-hand body resistance will influence the measurement! Record this resistance value for future use.

Build a one-battery, one-resistor circuit. A terminal strip is shown in the illustration, but any form of circuit construction is okay. Set your multimeter to the appropriate voltage range and measure voltage across the resistor as it is being powered by the battery. Record this voltage value along with the resistance value previously measured.

Set your multimeter to the highest current range available. Break the circuit and connect the ammeter within that break, so it becomes a part of the circuit, in series with the battery and resistor. Select the best current range: whichever one gives the strongest meter indication

without over-ranging the meter. If your multimeter is autoranging, of course, you need not bother with setting ranges. Record this current value along with the resistance and voltage values previously recorded.

Taking the measured figures for voltage and resistance, use the Ohm's Law equation to calculate circuit current. Compare this calculated figure with the measured figure for circuit current:

Ohm's Law
(solving for current)

$$I = \frac{E}{R}$$

Where,

E = Voltage in volts

I = Current in amps

R = Resistance in ohms

Taking the measured figures for voltage and current, use the Ohm's Law equation to calculate circuit resistance. Compare this calculated figure with the measured figure for circuit resistance:

Ohm's Law
(solving for resistance)

$$R = \frac{E}{I}$$

Finally, taking the measured figures for resistance and current, use the Ohm's Law equation to calculate circuit voltage. Compare this calculated figure with the measured figure for circuit voltage:

Ohm's Law
(solving for voltage)

$$E = IR$$

There should be close agreement between all measured and all calculated figures. Any differences in respective quantities of voltage, current, or resistance are most likely due to meter inaccuracies. These differences should be rather small, no more than several percent. Some meters, of course, are more accurate than others!

Substitute different resistors in the circuit and re-take all resistance, voltage, and current measurements. Re-calculate these figures and check for agreement with the experimental data (measured quantities). Also note the simple mathematical relationship between changes in resistor value and changes in circuit current. Voltage should remain approximately the same for any resistor size inserted into the circuit, because it is the nature of a battery to maintain voltage at a constant level.

2.6 Nonlinear resistance

PARTS AND MATERIALS

- Calculator (or pencil and paper for doing arithmetic)
- 6-volt battery
- Low-voltage incandescent lamp (Radio Shack catalog # 272-1130 or equivalent)

CROSS-REFERENCES

Lessons In Electric Circuits, Volume 1, chapter 2: "Ohm's Law"

LEARNING OBJECTIVES

- Voltmeter use
- Ammeter use
- Ohmmeter use
- Use of Ohm's Law
- Realization that some resistances are unstable!
- Scientific method

SCHEMATIC DIAGRAM

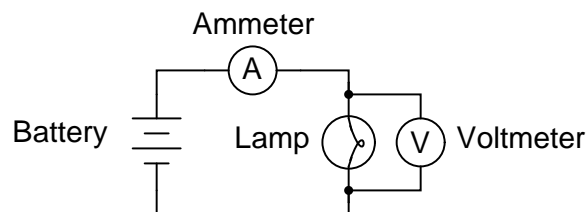

ILLUSTRATION

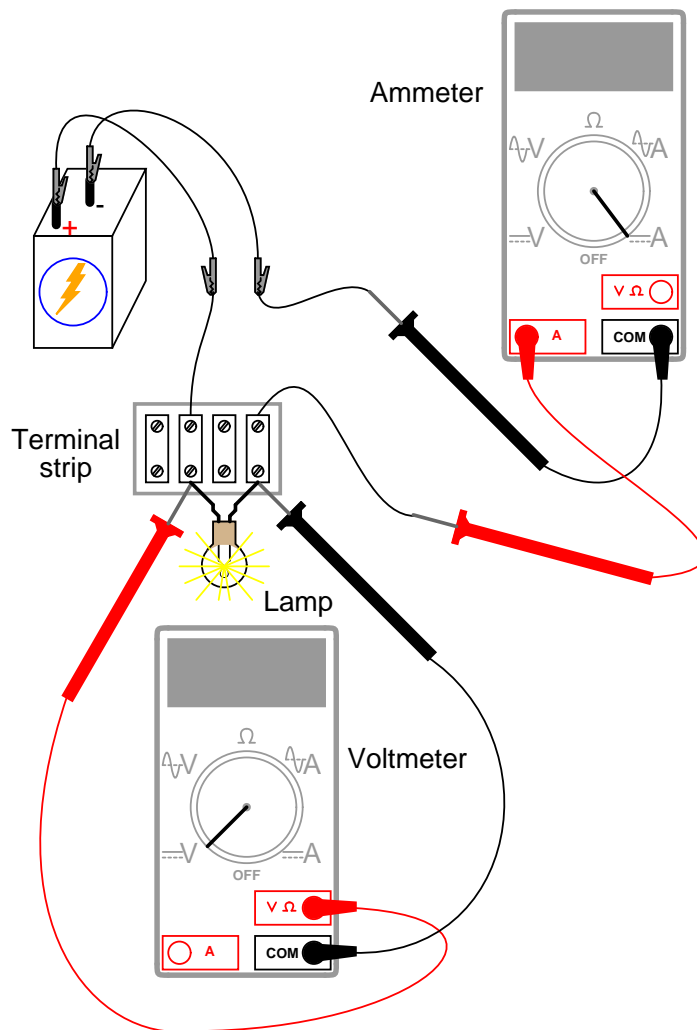

INSTRUCTIONS

Measure the resistance of the lamp with your multimeter. This resistance figure is due to the thin metal "filament" inside the lamp. It has substantially more resistance than a jumper wire, but less than any of the resistors from the last experiment. Record this resistance value for future use.

Build a one-battery, one-lamp circuit. Set your multimeter to the appropriate voltage range and measure voltage across the lamp as it is energized (lit). Record this voltage value along with the resistance value previously measured.

Set your multimeter to the highest current range available. Break the circuit and connect the ammeter within that break, so it becomes a part of the circuit, in series with the battery and lamp. Select the best current range: whichever one gives the strongest meter indication without over-ranging the meter. If your multimeter is autoranging, of course, you need not

both with setting ranges. Record this current value along with the resistance and voltage values previously recorded.

Taking the measured figures for voltage and resistance, use the Ohm's Law equation to calculate circuit current. Compare this calculated figure with the measured figure for circuit current:

Ohm's Law
(solving for current)

$$I = \frac{E}{R}$$

Where,

E = Voltage in volts

I = Current in amps

R = Resistance in ohms

What you should find is a marked difference between measured current and calculated current: the calculated figure is *much* greater. Why is this?

To make things more interesting, try measuring the lamp's resistance again, this time using a different model of meter. You will need to disconnect the lamp from the battery circuit in order to obtain a resistance reading, because voltages outside of the meter interfere with resistance measurement. This is a general rule that should be remembered: measure resistance only on an *unpowered* component!

Using a different ohmmeter, the lamp will probably register as a different value of resistance. Usually, analog meters give higher lamp resistance readings than digital meters.

This behavior is very different from that of the resistors in the last experiment. Why? What factor(s) might influence the resistance of the lamp filament, and how might those factors be different between conditions of lit and unlit, or between resistance measurements taken with different types of meters?

This problem is a good test case for the application of scientific method. Once you've thought of a possible reason for the lamp's resistance changing between lit and unlit conditions, try to duplicate that cause by some other means. For example, if you think the lamp resistance might change as it is exposed to light (its own light, when lit), and that this accounts for the difference between the measured and calculated circuit currents, try exposing the lamp to an external source of light while measuring its resistance. If you measure substantial resistance change as a result of light exposure, then your hypothesis has some evidential support. If not, then your hypothesis has been falsified, and another cause must be responsible for the change in circuit current.

2.7 Power dissipation

PARTS AND MATERIALS

- Calculator (or pencil and paper for doing arithmetic)
- 6 volt battery
- Two 1/4 watt resistors: 10 Ω and 330 Ω .
- Small thermometer

The resistor values need not be exact, but within five percent of the figures specified (+/- 0.5 Ω for the 10 Ω resistor; +/- 16.5 Ω for the 330 Ω resistor). Color codes for 5% tolerance 10 Ω and 330 Ω resistors are as follows: Brown, Black, Black, Gold (10, +/- 5%), and Orange, Orange, Brown, Gold (330, +/- 5%).

Do not use any battery size other than 6 volts for this experiment.

The thermometer should be as small as possible, to facilitate rapid detection of heat produced by the resistor. I recommend a medical thermometer, the type used to take body temperature.

CROSS-REFERENCES

Lessons In Electric Circuits, Volume 1, chapter 2: "Ohm's Law"

LEARNING OBJECTIVES

- Voltmeter use
- Ammeter use
- Ohmmeter use
- Use of Joule's Law
- Importance of component power ratings
- Significance of electrically common points

SCHEMATIC DIAGRAM

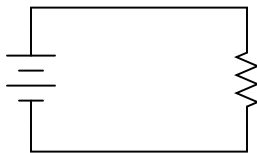

ILLUSTRATION

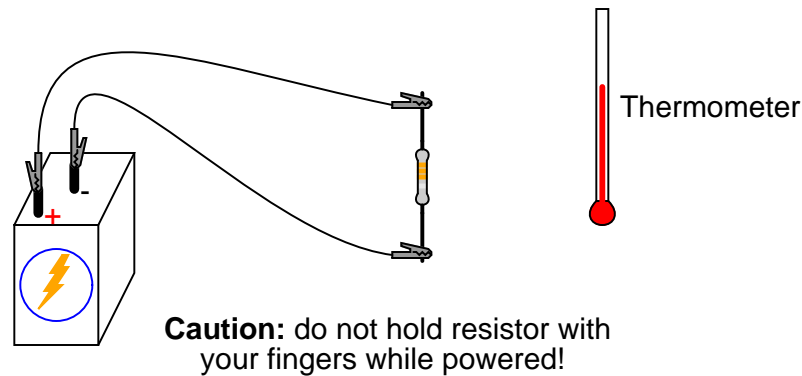

INSTRUCTIONS

Measure each resistor's resistance with your ohmmeter, noting the exact values on a piece of paper for later reference.

Connect the $330\ \Omega$ resistor to the 6 volt battery using a pair of jumper wires as shown in the illustration. Connect the jumper wires to the resistor terminals *before* connecting the other ends to the battery. This will ensure your fingers are not touching the resistor when battery power is applied.

You might be wondering why I advise no bodily contact with the powered resistor. This is because it will become hot when powered by the battery. You will use the thermometer to measure the temperature of each resistor when powered.

With the $330\ \Omega$ resistor connected to the battery, measure voltage with a voltmeter. In measuring voltage, there is more than one way to obtain a proper reading. Voltage may be measured directly across the battery, or directly across the resistor. Battery voltage is the same as resistor voltage in this circuit, since those two components share the same set of electrically common points: one side of the resistor is directly connected to one side of the battery, and the other side of the resistor is directly connected to the other side of the battery.

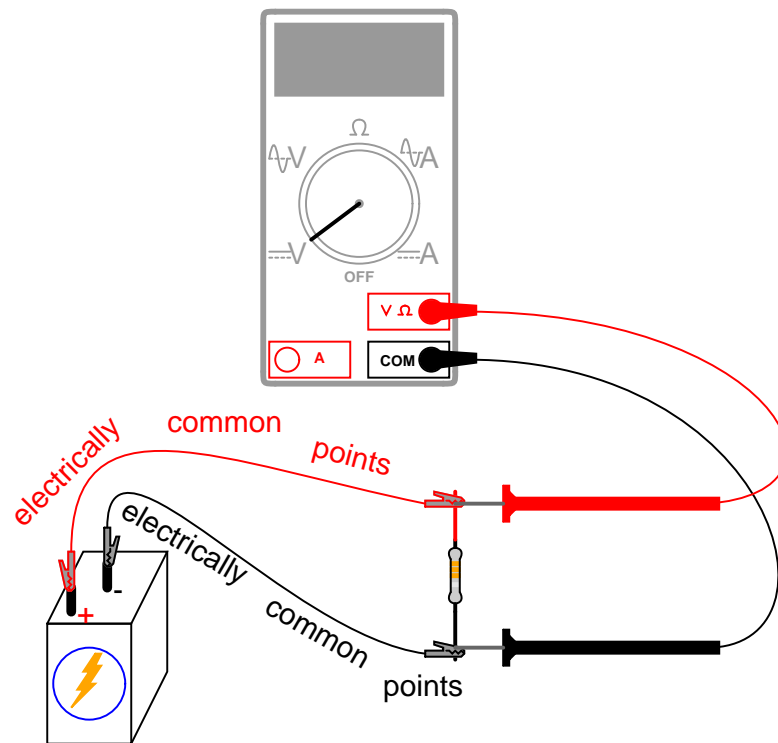

All points of contact along the upper wire in the illustration (colored red) are electrically common to each other. All points of contact along the lower wire (colored black) are likewise electrically common to each other. Voltage measured between any point on the upper wire and any point on the lower wire should be the same. Voltage measured *between any two common points*, however, should be zero.

Using an ammeter, measure current through the circuit. Again, there is no one "correct" way to measure current, so long as the ammeter is placed *within the flow-path* of electrons through the resistor and not across a source of voltage. To do this, make a break in the circuit, and place the ammeter *within* that break: connect the two test probes to the two wire or terminal ends left open from the break. One viable option is shown in the following illustration:

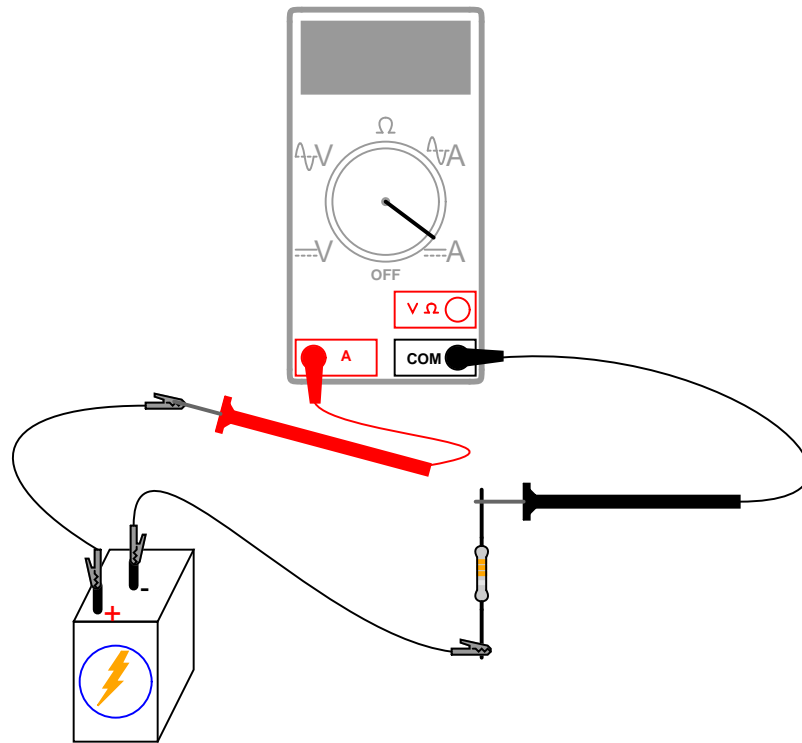

Now that you've measured and recorded resistor resistance, circuit voltage, and circuit current, you are ready to calculate *power* dissipation. Whereas voltage is the measure of electrical "push" motivating electrons to move through a circuit, and current is the measure of electron flow rate, power is the measure of *work-rate*: how fast work is being done in the circuit. It takes a certain amount of work to push electrons through a resistance, and power is a description of how *rapidly* that work is taking place. In mathematical equations, power is symbolized by the letter "P" and measured in the unit of the Watt (W).

Power may be calculated by any one of three equations – collectively referred to as Joule's Law – given any two out of three quantities of voltage, current, and resistance:

Joule's Law
(solving for power)

$$P = IE$$

$$P = I^2R$$

$$P = \frac{E^2}{R}$$

Try calculating power in this circuit, using the three measured values of voltage, current, and resistance. Any way you calculate it, the power dissipation figure should be roughly the same. Assuming a battery with 6.000 volts and a resistor of exactly 330 Ω , the power dissi-

pation will be 0.1090909 watts, or 109.0909 milli-watts (mW), to use a metric prefix. Since the resistor has a power rating of 1/4 watt (0.25 watts, or 250 mW), it is more than capable of sustaining this level of power dissipation. Because the actual power level is almost half the rated power, the resistor should become noticeably warm but it should not *overheat*. Touch the thermometer end to the middle of the resistor and see how warm it gets.

The power rating of any electrical component does not tell us how much power it *will* dissipate, but simply how much power it *may* dissipate without sustaining damage. If the actual amount of dissipated power exceeds a component's power rating, that component will increase temperature to the point of damage.

To illustrate, disconnect the 330 Ω resistor and replace it with the 10 Ω resistor. Again, avoid touching the resistor once the circuit is complete, as it will heat up rapidly. The safest way to do this is to disconnect one jumper wire from a battery terminal, then disconnect the 330 Ω resistor from the two alligator clips, then connect the 10 Ω resistor between the two clips, and finally reconnect the jumper wire back to the battery terminal.

Caution: keep the 10 Ω resistor away from any flammable materials when it is powered by the battery!

You may not have enough time to take voltage and current measurements before the resistor begins to smoke. At the first sign of distress, disconnect one of the jumper wires from a battery terminal to interrupt circuit current, and give the resistor a few moments to cool down. With power still disconnected, measure the resistor's resistance with an ohmmeter and note any substantial deviation from its original value. If the resistor still measures within +/- 5% of its advertised value (between 9.5 and 10.5 Ω), re-connect the jumper wire and let it smoke a bit more.

What trend do you notice with the resistor's value as it is damaged more and more by overpowering? It is typical of resistors to fail with a greater-than-normal resistance when overheated. This is often a self-protective mode of failure, as an increased resistance results in less current and (generally) less power dissipation, cooling it down again. However, the resistor's normal resistance value will not return if sufficiently damaged.

Performing some Joule's Law calculations for resistor power again, we find that a 10 Ω resistor connected to a 6 volt battery dissipates about 3.6 watts of power, about 14.4 *times* its rated power dissipation. Little wonder it smokes so quickly after connection to the battery!

2.8 Circuit with a switch

PARTS AND MATERIALS

- 6-volt battery
- Low-voltage incandescent lamp (Radio Shack catalog # 272-1130 or equivalent)
- Long lengths of wire, 22-gauge or larger
- Household light switch (these are readily available at any hardware store)

Household light switches are a bargain for students of basic electricity. They are readily available, very inexpensive, and almost impossible to damage with battery power. Do not get "dimmer" switches, just the simple on-off "toggle" variety used for ordinary household wall-mounted light controls.

CROSS-REFERENCES

Lessons In Electric Circuits, Volume 1, chapter 1: "Basic Concepts of Electricity"

LEARNING OBJECTIVES

- Switch behavior
- Using an ohmmeter to check switch action

SCHEMATIC DIAGRAM

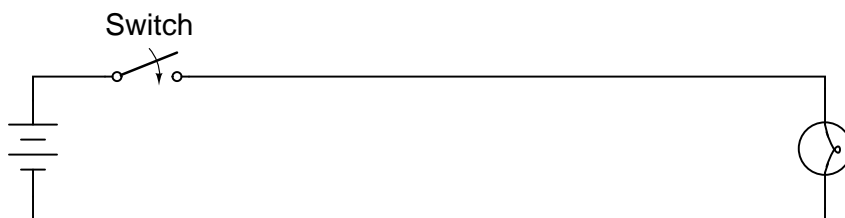

ILLUSTRATION

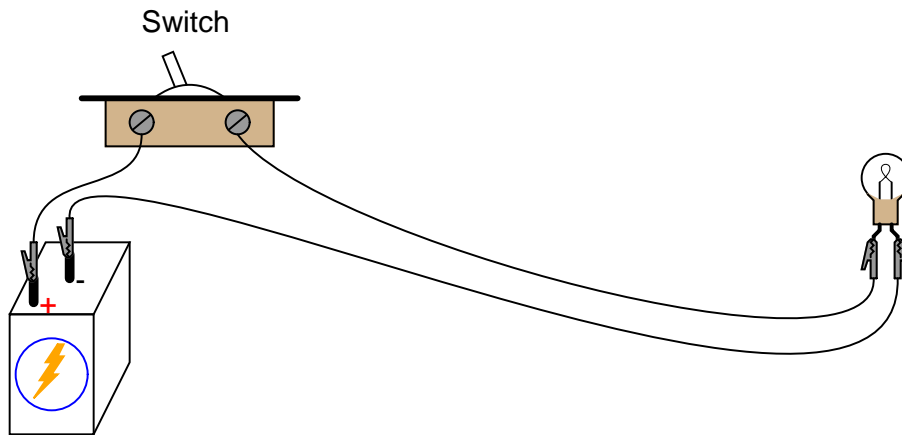

INSTRUCTIONS

Build a one-battery, one-switch, one-lamp circuit as shown in the schematic diagram and in the illustration. This circuit is most impressive when the wires are *long*, as it shows how the switch is able to control circuit current no matter how physically large the circuit may be.

Measure voltage across the battery, across the switch (measure from one screw terminal to another with the voltmeter), and across the lamp with the switch in both positions. When the switch is turned off, it is said to be *open*, and the lamp will go out just the same as if a wire were pulled loose from a terminal. As before, any break in the circuit *at any location* causes the lamp to immediately de-energize (darken).

2.9 Electromagnetism

PARTS AND MATERIALS

- 6-volt battery
- Magnetic compass
- Small permanent magnet
- Spool of 28-gauge magnet wire
- Large bolt, nail, or steel rod
- Electrical tape

Magnet wire is a term for thin-gauge copper wire with enamel insulation instead of rubber or plastic insulation. Its small size and very thin insulation allow for many "turns" to be wound in a compact coil. You will need enough magnet wire to wrap hundreds of turns around the bolt, nail, or other rod-shaped steel form.

Be sure to select a bolt, nail, or rod that is *magnetic*. Stainless steel, for example, is non-magnetic and will not function for the purpose of an electromagnet coil! The ideal material for this experiment is *soft iron*, but any commonly available steel will suffice.

CROSS-REFERENCES

Lessons In Electric Circuits, Volume 1, chapter 14: "Magnetism and Electromagnetism"

LEARNING OBJECTIVES

- Application of the left-hand rule
- Electromagnet construction

SCHEMATIC DIAGRAM

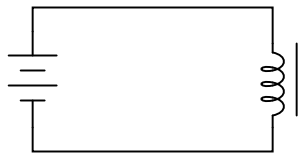

ILLUSTRATION

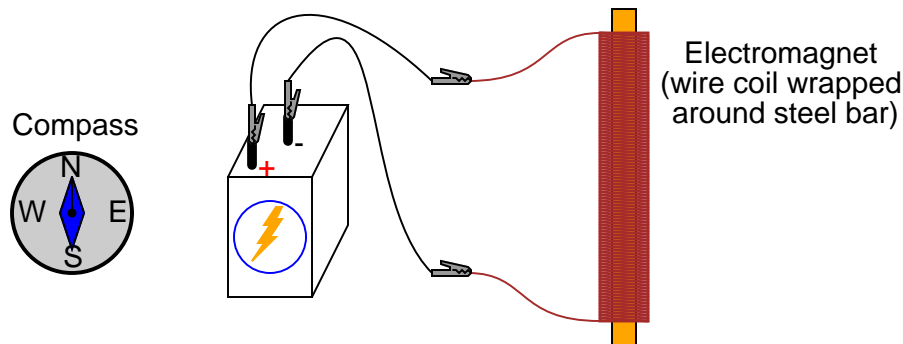

INSTRUCTIONS

Wrap a single layer of electrical tape around the steel bar (or bolt, or nail) to protect the wire from abrasion. Proceed to wrap several hundred turns of wire around the steel bar, making the coil as even as possible. It is okay to overlap wire, and it is okay to wrap in the same style that a fishing reel wraps line around the spool. The only rule you *must* follow is that all turns must be wrapped around the bar in the same direction (no reversing from clockwise to counter-clockwise!). I find that a drill press works as a great tool for coil winding: clamp the rod in the drill's chuck as if it were a drill bit, then turn the drill motor on at a slow speed and let it do the wrapping! This allows you to feed wire onto the rod in a very steady, even manner.

After you've wrapped several hundred turns of wire around the rod, wrap a layer or two of electrical tape over the wire coil to secure the wire in place. Scrape the enamel insulation off the ends of the coil wires for connection to jumper leads, then connect the coil to a battery.

When electric current goes through the coil, it will produce a strong magnetic field: one "pole" at each end of the rod. This phenomenon is known as *electromagnetism*. The magnetic compass is used to identify the "North" and "South" poles of the electromagnet.

With the electromagnet energized (connected to the battery), place a permanent magnet near one pole and note whether there is an attractive or repulsive force. Reverse the orientation of the permanent magnet and note the difference in force.

Electromagnetism has many applications, including relays, electric motors, solenoids, doorbells, buzzers, computer printer mechanisms, and magnetic media "write" heads (tape recorders, disk drives).

You might notice a significant spark whenever the battery is disconnected from the electromagnet coil: much greater than the spark produced if the battery is simply short-circuited. This spark is the result of a high-voltage surge created whenever current is suddenly interrupted through the coil. The effect is known as *inductive "kickback"* and is capable of delivering a small but harmless electric shock! To avoid receiving this shock, do not place your body across the break in the circuit when de-energizing! Use one hand at a time when un-powering the coil and you'll be perfectly safe. This phenomenon will be explored in greater detail in the next chapter (DC Circuits).

2.10 Electromagnetic induction

PARTS AND MATERIALS

- Electromagnet from previous experiment
- Permanent magnet

See previous experiment for instructions on electromagnet construction.

CROSS-REFERENCES

Lessons In Electric Circuits, Volume 1, chapter 14: "Magnetism and Electromagnetism"

LEARNING OBJECTIVES

- Relationship between magnetic field strength and induced voltage

SCHEMATIC DIAGRAM

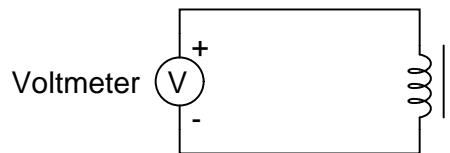

ILLUSTRATION

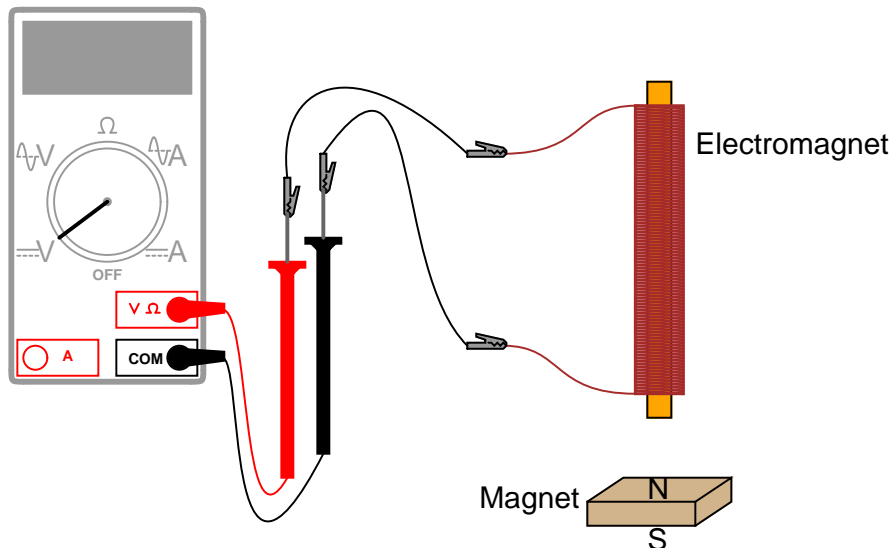

INSTRUCTIONS

Electromagnetic induction is the complementary phenomenon to electromagnetism. Instead of producing a magnetic field from electricity, we produce electricity from a magnetic field. There is one important difference, though: whereas electromagnetism produces a steady magnetic field from a steady electric current, electromagnetic induction requires *motion* between the magnet and the coil to produce a voltage.

Connect the multimeter to the coil, and set it to the most sensitive DC voltage range available. Move the magnet *slowly* to and from one end of the electromagnet, noting the polarity and magnitude of the induced voltage. Experiment with moving the magnet, and discover for yourself what factor(s) determine the amount of voltage induced. Try the other end of the coil and compare results. Try the other end of the permanent magnet and compare.

If using an analog multimeter, be sure to use long jumper wires and locate the meter far away from the coil, as the magnetic field from the permanent magnet may affect the meter's operation and produce false readings. Digital meters are unaffected by magnetic fields.

Chapter 3

DC CIRCUITS

Contents

3.1 Introduction	59
3.2 Series batteries	60
3.3 Parallel batteries	63
3.4 Voltage divider	67
3.5 Current divider	78
3.6 Potentiometer as a voltage divider	87
3.7 Potentiometer as a rheostat	93
3.8 Precision potentiometer	99
3.9 Rheostat range limiting	102
3.10 Thermoelectricity	109
3.11 Make your own multimeter	112
3.12 Sensitive voltage detector	117
3.13 Potentiometric voltmeter	122
3.14 4-wire resistance measurement	127
3.15 A very simple computer	131
3.16 Potato battery	136
3.17 Capacitor charging and discharging	138
3.18 Rate-of-change indicator	142

3.1 Introduction

”DC” stands for **D**irect **C**urrent, which can refer to either voltage or current in a constant polarity or direction, respectively. These experiments are designed to introduce you to several important concepts of electricity related to DC circuits.

3.2 Series batteries

PARTS AND MATERIALS

- Two 6-volt batteries
- One 9-volt battery

Actually, any size batteries will suffice for this experiment, but it is recommended to have at least two different voltages available to make it more interesting.

CROSS-REFERENCES

Lessons In Electric Circuits, Volume 1, chapter 5: "Series and Parallel Circuits"

Lessons In Electric Circuits, Volume 1, chapter 11: "Batteries and Power Systems"

LEARNING OBJECTIVES

- How to connect batteries to obtain different voltage levels

SCHEMATIC DIAGRAM

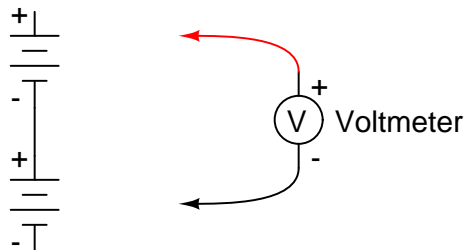

ILLUSTRATION

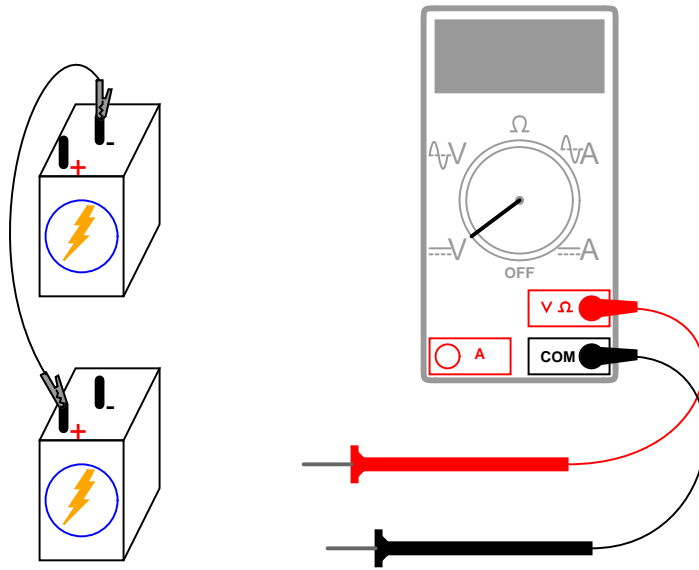

INSTRUCTIONS

Connecting components in *series* means to connect them in-line with each other, so that there is but a single path for electrons to flow through them all. If you connect batteries so that the positive of one connects to the negative of the other, you will find that their respective voltages add. Measure the voltage across each battery individually as they are connected, then measure the total voltage across them both, like this:

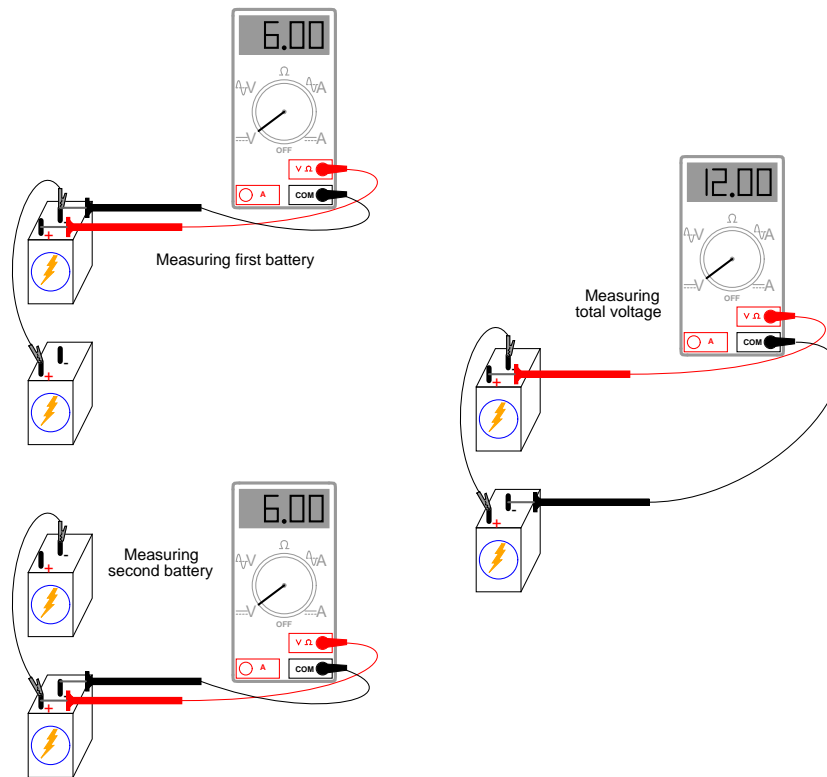

Try connecting batteries of different sizes in series with each other, for instance a 6-volt battery with a 9-volt battery. What is the total voltage in this case? Try reversing the terminal connections of just one of these batteries, so that they are opposing each other like this:

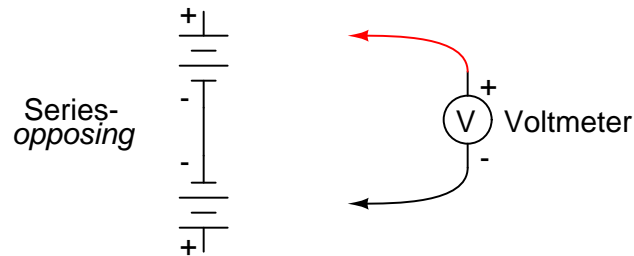

How does the total voltage compare in this situation to the previous one with both batteries "aiding?" Note the polarity of the total voltage as indicated by the voltmeter indication and test probe orientation. Remember, if the meter's digital indication is a positive number, the red probe is positive (+) and the black probe negative (-); if the indication is a negative number, the polarity is "backward" (red=negative, black=positive). Analog meters simply will not read properly if reverse-connected, because the needle tries to move the wrong direction (left instead of right). Can you predict what the overall voltage polarity will be, knowing the polarities of the individual batteries and their respective strengths?

3.3 Parallel batteries

PARTS AND MATERIALS

- Four 6-volt batteries
- 12-volt light bulb, 25 or 50 watt
- Lamp socket

High-wattage 12-volt lamps may be purchased from recreational vehicle (RV) and boating supply stores. Common sizes are 25 watt and 50 watt. This lamp will be used as a "heavy" load for your batteries (*heavy load* = one that draws substantial current).

A regular household (120 volt) lamp socket will work just fine for these low-voltage "RV" lamps.

CROSS-REFERENCES

Lessons In Electric Circuits, Volume 1, chapter 5: "Series and Parallel Circuits"

Lessons In Electric Circuits, Volume 1, chapter 11: "Batteries and Power Systems"

LEARNING OBJECTIVES

- Voltage source regulation
- Boosting current capacity through parallel connections

SCHEMATIC DIAGRAM

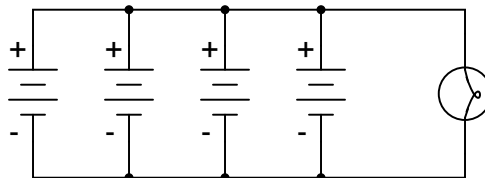

ILLUSTRATION

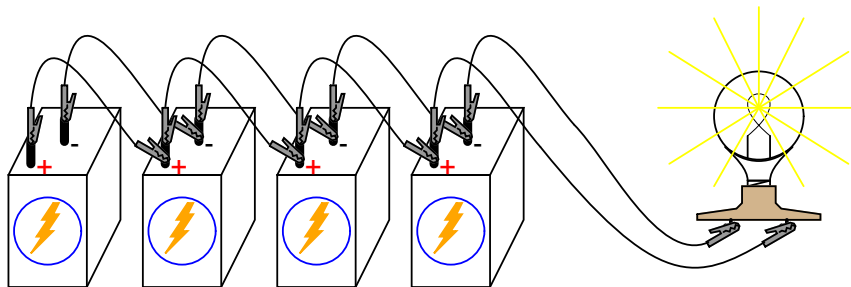

INSTRUCTIONS

Begin this experiment by connecting one 6-volt battery to the lamp. The lamp, designed to operate on 12 volts, should glow dimly when powered by the 6-volt battery. Use your voltmeter to read voltage across the lamp like this:

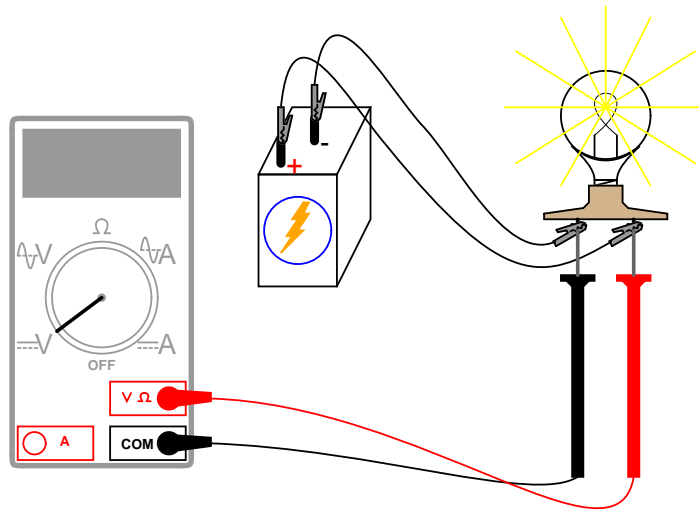

The voltmeter should register a voltage lower than the usual voltage of the battery. If you use your voltmeter to read the voltage directly at the battery terminals, you will measure a low voltage there as well. Why is this? The large current drawn by the high-power lamp causes the voltage at the battery terminals to "sag" or "droop," due to voltage dropped across resistance internal to the battery.

We may overcome this problem by connecting batteries in *parallel* with each other, so that each battery only has to supply a fraction of the total current demanded by the lamp. Parallel connections involve making all the positive (+) battery terminals electrically common to each other by connection through jumper wires, and all negative (-) terminals common to each other as well. Add one battery at a time in parallel, noting the lamp voltage with the addition of each new, parallel-connected battery:

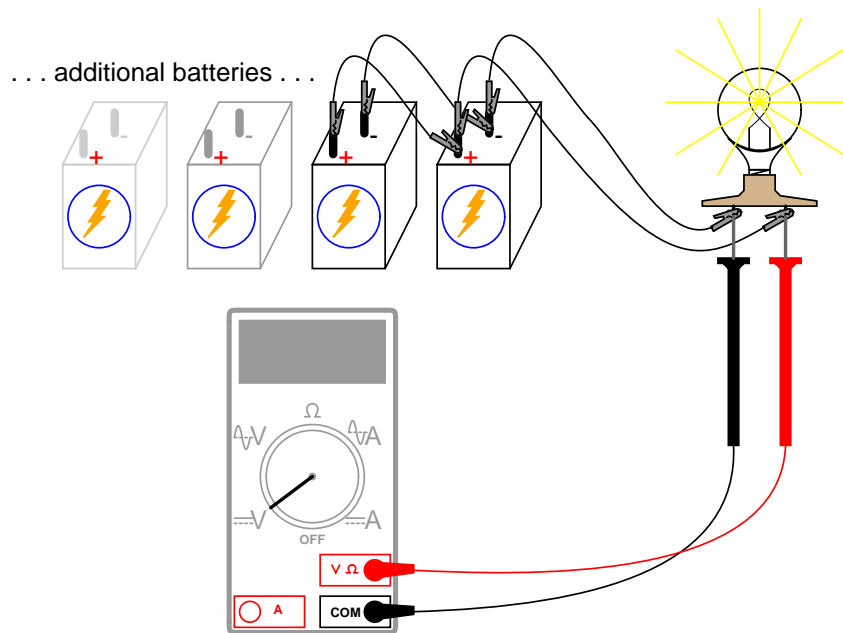

There should also be a noticeable difference in light intensity as the voltage "sag" is improved.

Try measuring the current of one battery and comparing it to the total current (light bulb current). Shown here is the easiest way to measure single-battery current:

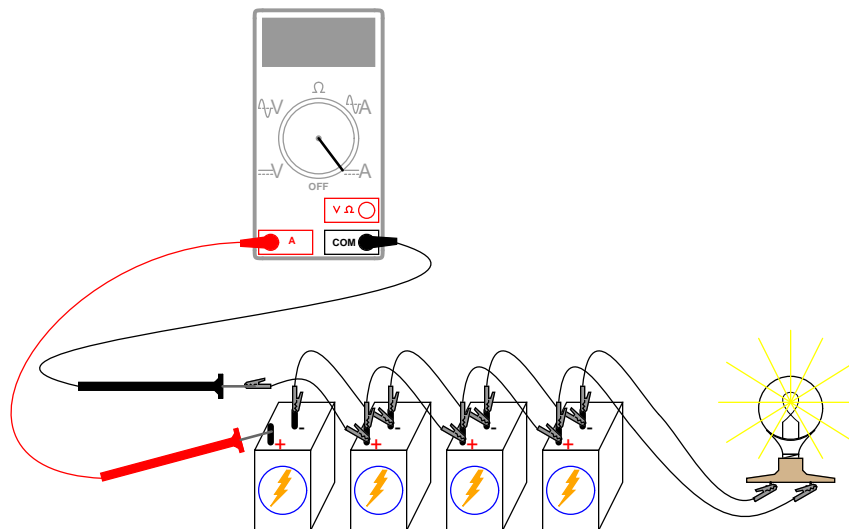

By breaking the circuit for just one battery, and inserting our ammeter within that break, we intercept the current of that one battery and are therefore able to measure it. Measuring total current involves a similar procedure: make a break somewhere in the path that total current must take, then insert the ammeter within than break:

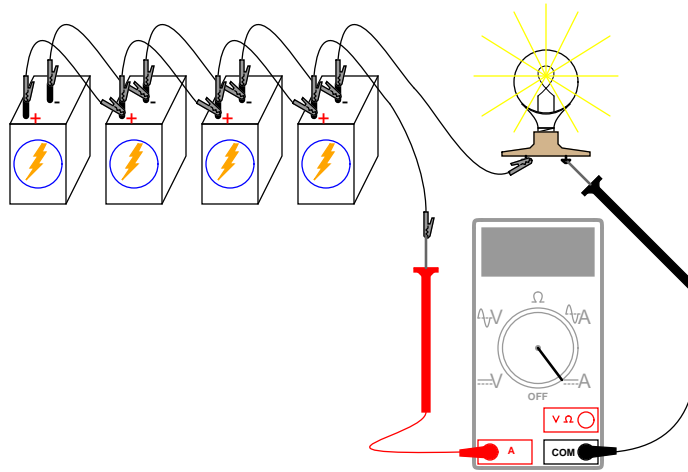

Note the difference in current between the single-battery and total measurements.

To obtain maximum brightness from the light bulb, a *series-parallel* connection is required. Two 6-volt batteries connected series-aiding will provide 12 volts. Connecting two of these series-connected battery pairs in parallel improves their current-sourcing ability for minimum voltage sag:

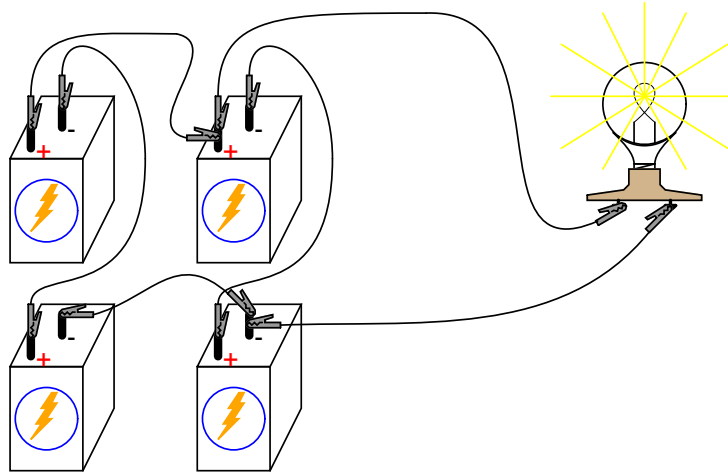

3.4 Voltage divider

PARTS AND MATERIALS

- Calculator (or pencil and paper for doing arithmetic)
- 6-volt battery
- Assortment of resistors between 1 K Ω and 100 k Ω in value

I'm purposely restricting the resistance values between 1 k Ω and 100 k Ω for the sake of obtaining accurate voltage and current readings with your meter. With very low resistance values, the internal resistance of the ammeter has a significant impact on measurement accuracy. Very high resistance values may cause problems for voltage measurement, the internal resistance of the voltmeter substantially changing circuit resistance when it is connected in parallel with a high-value resistor.

CROSS-REFERENCES

Lessons In Electric Circuits, Volume 1, chapter 6: "Divider Circuits and Kirchhoff's Laws"

LEARNING OBJECTIVES

- Voltmeter use
- Ammeter use
- Ohmmeter use
- Use of Ohm's Law
- Use of Kirchhoff's Voltage Law ("KVL")
- Voltage divider design

SCHEMATIC DIAGRAM

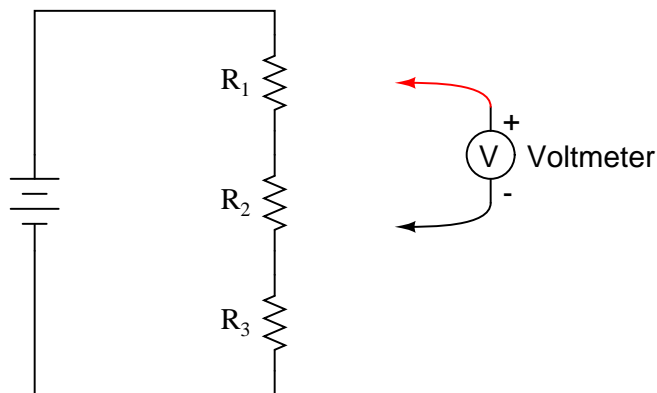

ILLUSTRATION

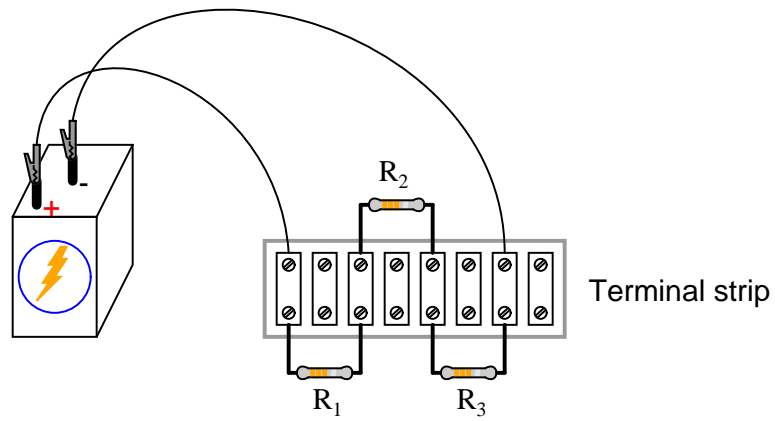
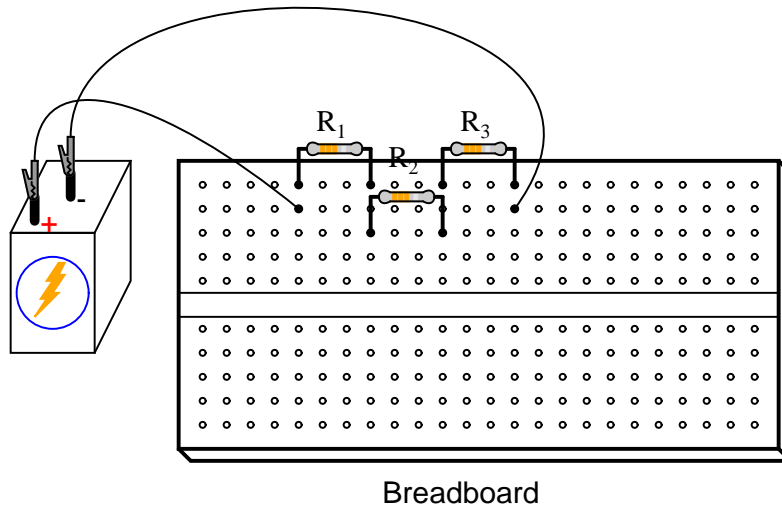

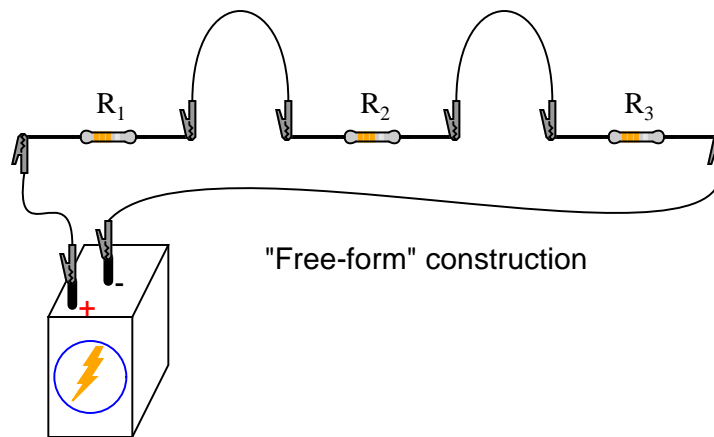

INSTRUCTIONS

Shown here are three different methods of circuit construction: on a breadboard, on a terminal strip, and "free-form." Try building the same circuit each way to familiarize yourself with the different construction techniques and their respective merits. The "free-form" method – where all components are connected together with "alligator-" style jumper wires – is the least professional, but appropriate for a simple experiment such as this. Breadboard construction is versatile and allows for high component density (many parts in a small space), but is quite temporary. Terminal strips offer a much more permanent form of construction at the cost of low component density.

Select three resistors from your resistor assortment and measure the resistance of each one with an ohmmeter. Note these resistance values with pen and paper, for reference in your circuit calculations.

Connect the three resistors in series, and to the 6-volt battery, as shown in the illustrations. Measure battery voltage with a voltmeter after the resistors have been connected to it, noting this voltage figure on paper as well. It is advisable to measure battery voltage while its powering the resistor circuit because this voltage may differ slightly from a no-load condition. We saw this effect exaggerated in the "parallel battery" experiment while powering a high-wattage lamp: battery voltage tends to "sag" or "droop" under load. Although this three-resistor circuit should not present a heavy enough load (not enough current drawn) to cause significant voltage "sag," measuring battery voltage under load is a good scientific practice because it provides more realistic data.

Use Ohm's Law ($I=E/R$) to calculate circuit current, then verify this calculated value by measuring current with an ammeter like this ("terminal strip" version of the circuit shown as an arbitrary choice in construction method):

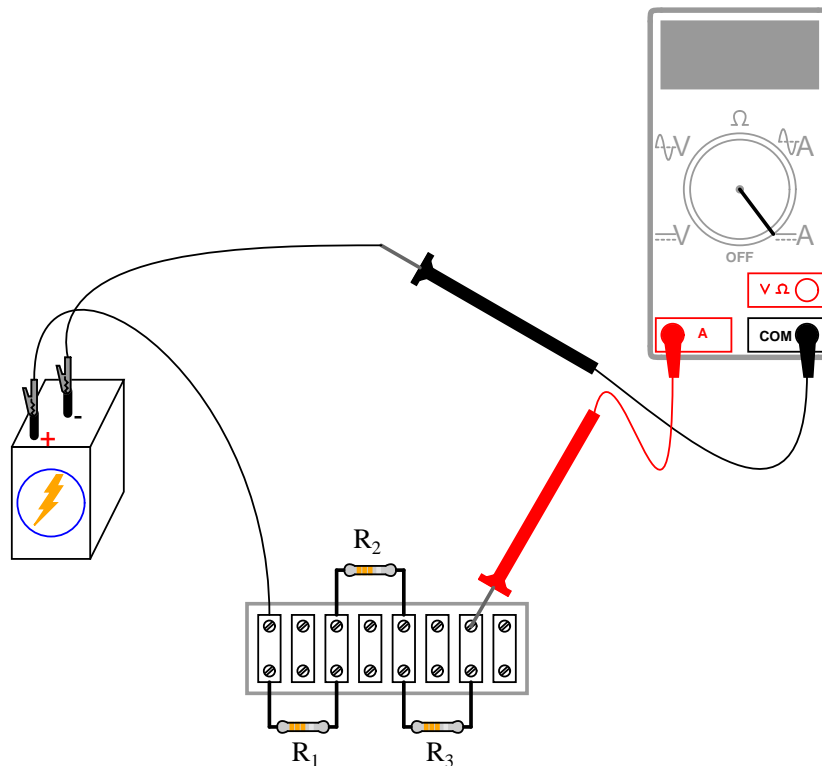

If your resistor values are indeed between $1\text{ k}\Omega$ and $100\text{ k}\Omega$, and the battery voltage approximately 6 volts, the current should be a very small value, in the milliamp (mA) or microamp (μA) range. When you measure current with a digital meter, the meter may show the appropriate metric prefix symbol (m or μ) in some corner of the display. These metric prefix telltales are easy to overlook when reading the display of a digital meter, so pay close attention!

The measured value of current should agree closely with your Ohm's Law calculation. Now, take that calculated value for current and multiply it by the respective resistances of each resistor to predict their voltage drops ($E=IR$). Switch your multimeter to the "voltage" mode and measure the voltage dropped across each resistor, verifying the accuracy of your predictions. Again, there should be close agreement between the calculated and measured voltage figures.

Each resistor voltage drop will be some fraction or percentage of the total voltage, hence the name *voltage divider* given to this circuit. This fractional value is determined by the resistance of the particular resistor and the total resistance. If a resistor drops 50% of the total battery voltage in a voltage divider circuit, that proportion of 50% will remain the same as long as the resistor values are not altered. So, if the total voltage is 6 volts, the voltage across that resistor will be 50% of 6, or 3 volts. If the total voltage is 20 volts, that resistor will drop 10 volts, or 50% of 20 volts.

The next part of this experiment is a validation of Kirchhoff's Voltage Law. For this, you need to identify each unique point in the circuit with a number. Points that are electrically common (directly connected to each other with insignificant resistance between) must bear the same number. An example using the numbers 0 through 3 is shown here in both illustrative

and schematic form. In the illustration, I show how points in the circuit may be labeled with small pieces of tape, numbers written on the tape:

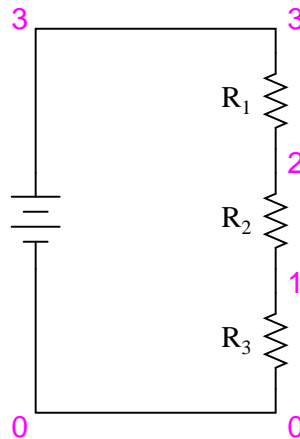
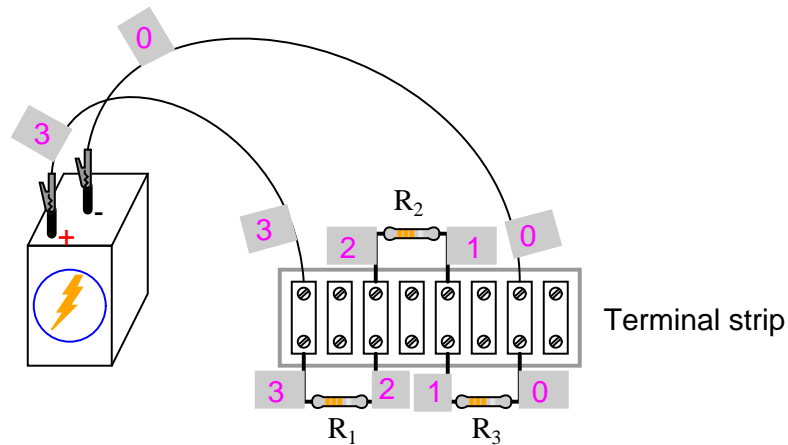

Using a *digital* voltmeter (this is important!), measure voltage drops around the loop formed by the points 0-1-2-3-0. Write on paper each of these voltages, along with its respective sign as indicated by the meter. In other words, if the voltmeter registers a negative voltage such as -1.325 volts, you should write that figure as a negative number. Do *not* reverse the meter probe connections with the circuit to make the number read "correctly." Mathematical sign is very significant in this phase of the experiment! Here is a sequence of illustrations showing how to "step around" the circuit loop, starting and ending at point 0:

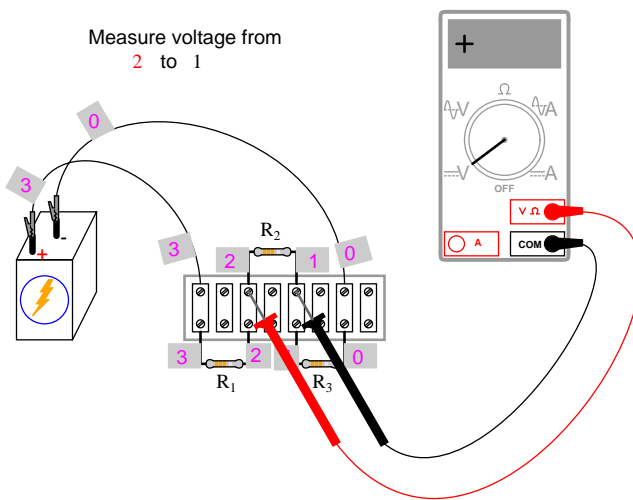
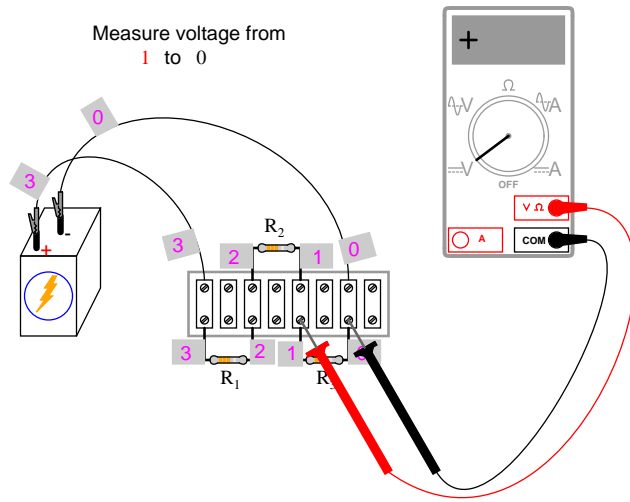

3.4. VOLTAGE DIVIDER

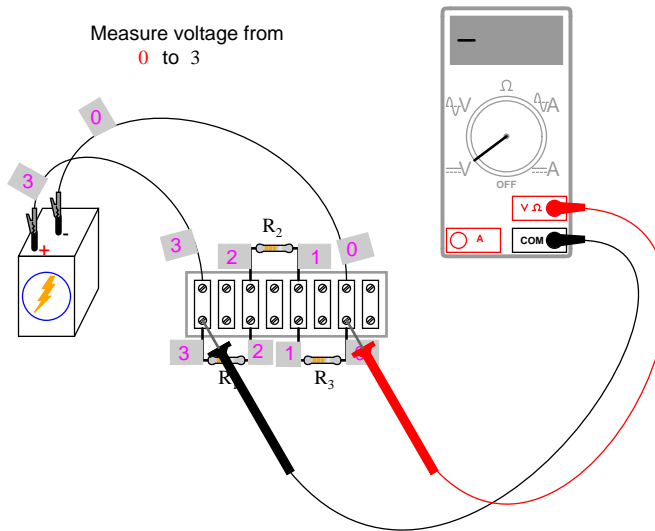
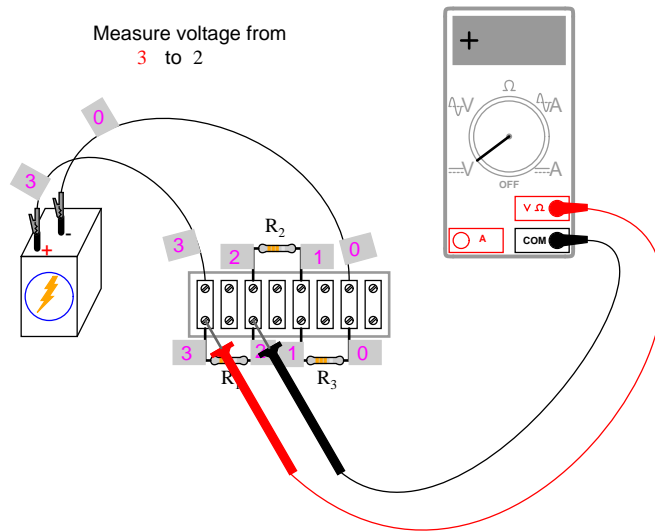

Using the voltmeter to "step" around the circuit in this manner yields three positive voltage figures and one negative:

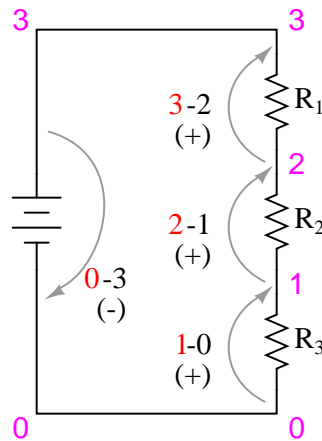

These figures, algebraically added ("algebraically" = respecting the signs of the numbers), should equal zero. This is the fundamental principle of Kirchhoff's Voltage Law: that the algebraic sum of all voltage drops in a "loop" add to zero.

It is important to realize that the "loop" stepped around does not have to be the same path that current takes in the circuit, or even a legitimate current path at all. The loop in which we tally voltage drops can be *any collection of points*, so long as it begins and ends with the same point. For example, we may measure and add the voltages in the loop 1-2-3-1, and they will form a sum of zero as well:

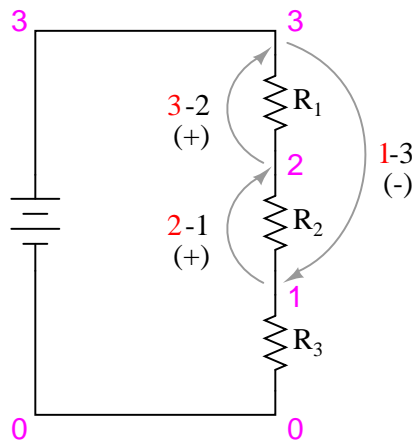

3.4. VOLTAGE DIVIDER

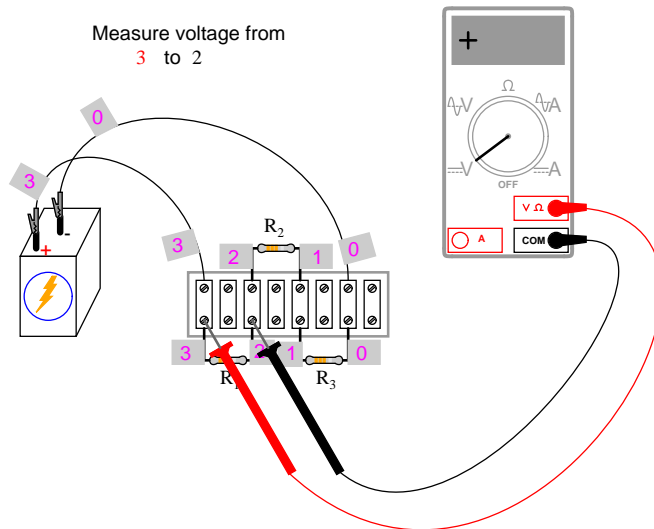
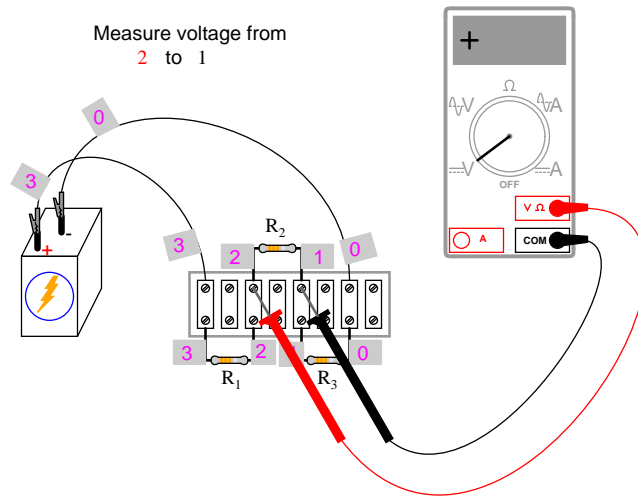

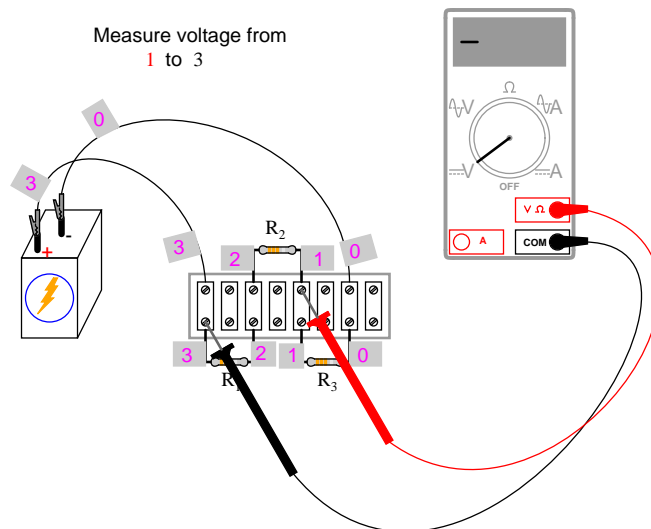

Try stepping between any set of points, in any order, around your circuit and see for yourself that the algebraic sum always equals zero. This Law holds true no matter what the configuration of the circuit: series, parallel, series-parallel, or even an irreducible network.

Kirchhoff's Voltage Law is a powerful concept, allowing us to predict the magnitude and polarity of voltages in a circuit by developing mathematical equations for analysis based on the truth of all voltages in a loop adding up to zero. This experiment is intended to give empirical evidence for and a deep understanding of Kirchhoff's Voltage Law as a general principle.

COMPUTER SIMULATION

Netlist (make a text file containing the following text, verbatim):

```
Voltage divider
v1 3 0
r1 3 2 5k
r2 2 1 3k
r3 1 0 2k
.dc v1 6 6 1
* Voltages around 0-1-2-3-0 loop algebraically add to zero:
.print dc v(1,0) v(2,1) v(3,2) v(0,3)
* Voltages around 1-2-3-1 loop algebraically add to zero:
.print dc v(2,1) v(3,2) v(1,3)
.end
```

This computer simulation is based on the point numbers shown in the previous diagrams for illustrating Kirchhoff's Voltage Law (points 0 through 3). Resistor values were chosen to provide 50%, 30%, and 20% proportions of total voltage across R_1 , R_2 , and R_3 , respectively. Feel free to modify the voltage source value (in the ".dc" line, shown here as 6 volts), and/or the resistor values.

When run, SPICE will print a line of text containing four voltage figures, then another line of text containing three voltage figures, along with lots of other text lines describing the

3.4. *VOLTAGE DIVIDER*

77

analysis process. Add the voltage figures in each line to see that the sum is zero.

3.5 Current divider

PARTS AND MATERIALS

- Calculator (or pencil and paper for doing arithmetic)
- 6-volt battery
- Assortment of resistors between 1 K Ω and 100 k Ω in value

CROSS-REFERENCES

Lessons In Electric Circuits, Volume 1, chapter 6: "Divider Circuits and Kirchhoff's Laws"

LEARNING OBJECTIVES

- Voltmeter use
- Ammeter use
- Ohmmeter use
- Use of Ohm's Law
- Use of Kirchhoff's Current Law (KCL)
- Current divider design

SCHEMATIC DIAGRAM

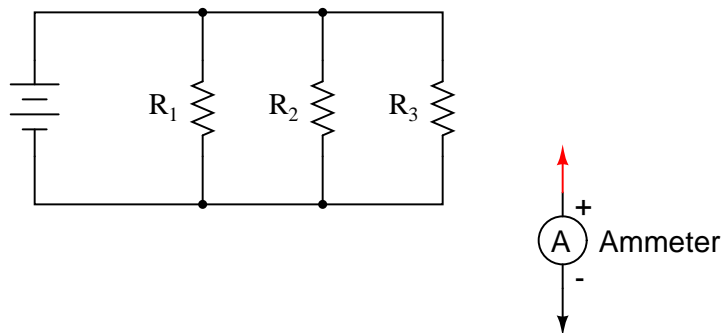

ILLUSTRATION

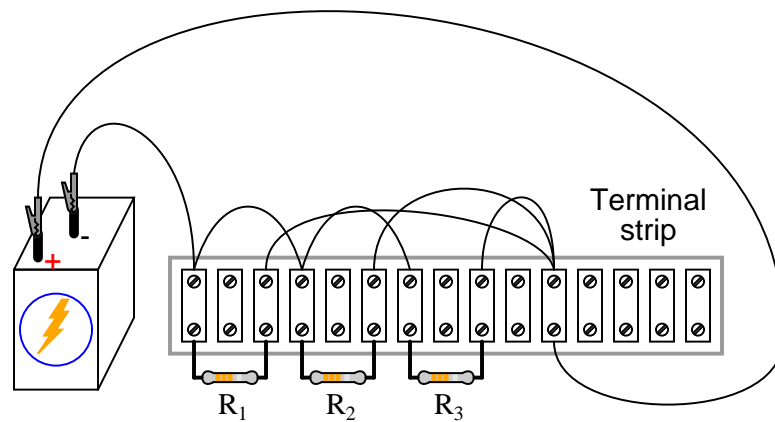
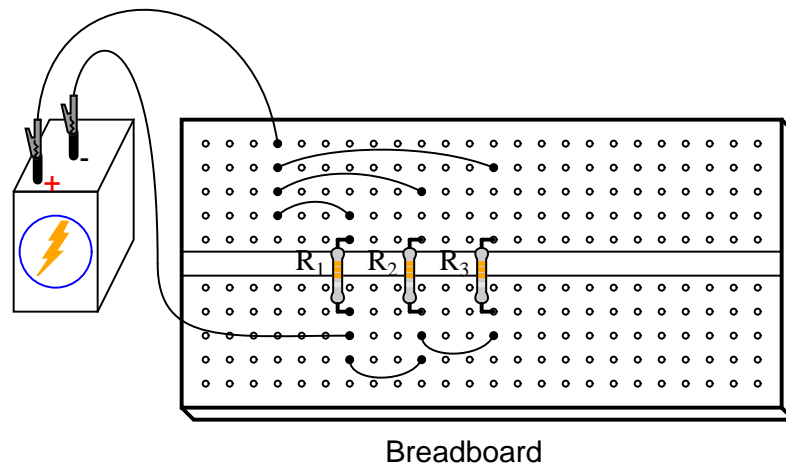

Normally, it is considered improper to secure more than two wires under a single terminal strip screw. In this illustration, I show three wires joining at the top screw of the rightmost lug used on this strip. This is done for the ease of proving a concept (of current *summing* at a circuit node), and does not represent professional assembly technique.

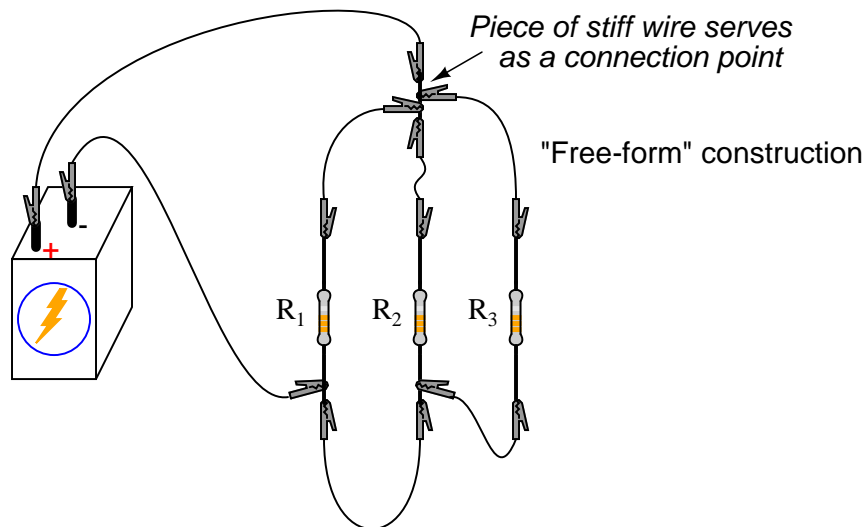

The non-professional nature of the "free-form" construction method merits no further comment.

INSTRUCTIONS

Once again, I show different methods of constructing the same circuit: breadboard, terminal strip, and "free-form." Experiment with all these construction formats and become familiar with their respective advantages and disadvantages.

Select three resistors from your resistor assortment and measure the resistance of each one with an ohmmeter. Note these resistance values with pen and paper, for reference in your circuit calculations.

Connect the three resistors in parallel to and each other, and with the 6-volt battery, as shown in the illustrations. Measure battery voltage with a voltmeter after the resistors have been connected to it, noting this voltage figure on paper as well. It is advisable to measure battery voltage while its powering the resistor circuit because this voltage may differ slightly from a no-load condition.

Measure voltage across each of the three resistors. What do you notice? In a series circuit, *current* is equal through all components at any given time. In a parallel circuit, *voltage* is the common variable between all components.

Use Ohm's Law ($I=E/R$) to calculate current through each resistor, then verify this calculated value by measuring current with a digital ammeter. Place the red probe of the ammeter at the point where the positive (+) ends of the resistors connect to each other and lift one resistor wire at a time, connecting the meter's black probe to the lifted wire. In this manner, measure each resistor current, noting both the magnitude of the current and the polarity. In these illustrations, I show an ammeter used to measure the current through R_1 :

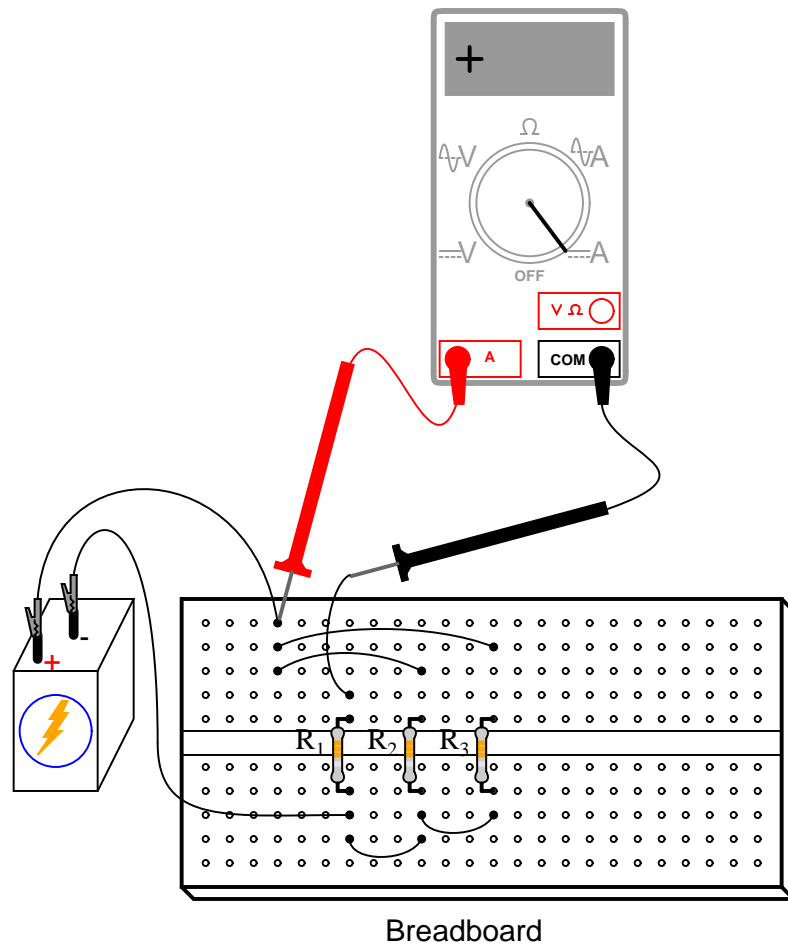

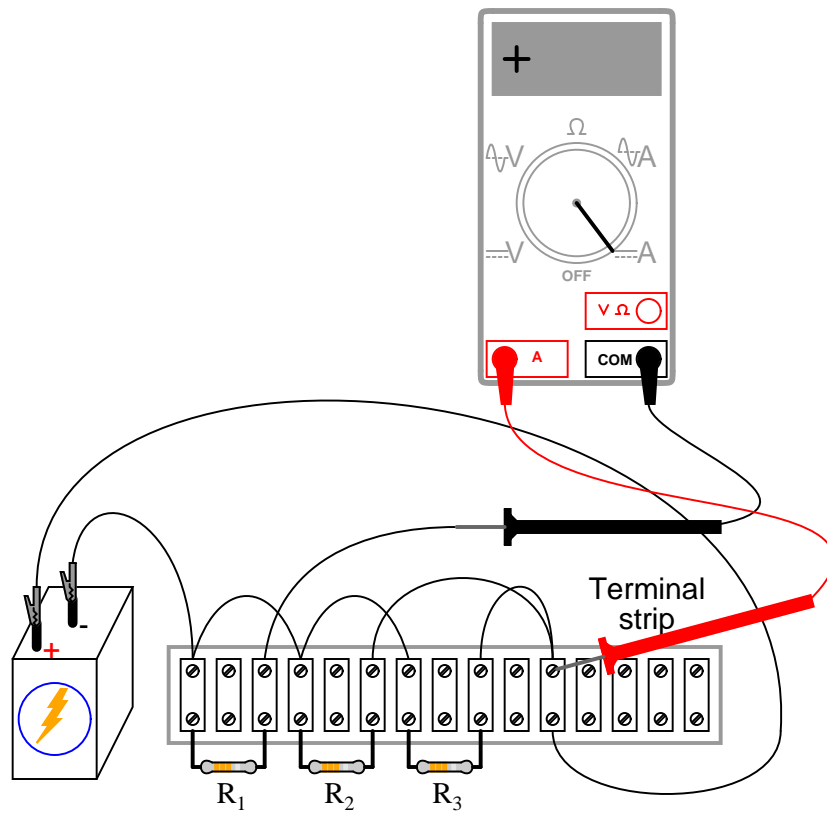

Measure current for each of the three resistors, comparing with the current figures calculated previously. With the digital ammeter connected as shown, all three indications should be positive, not negative.

Now, measure total circuit current, keeping the ammeter's red probe on the same point of the circuit, but disconnecting the wire leading to the positive (+) side of the battery and touching the black probe to it:

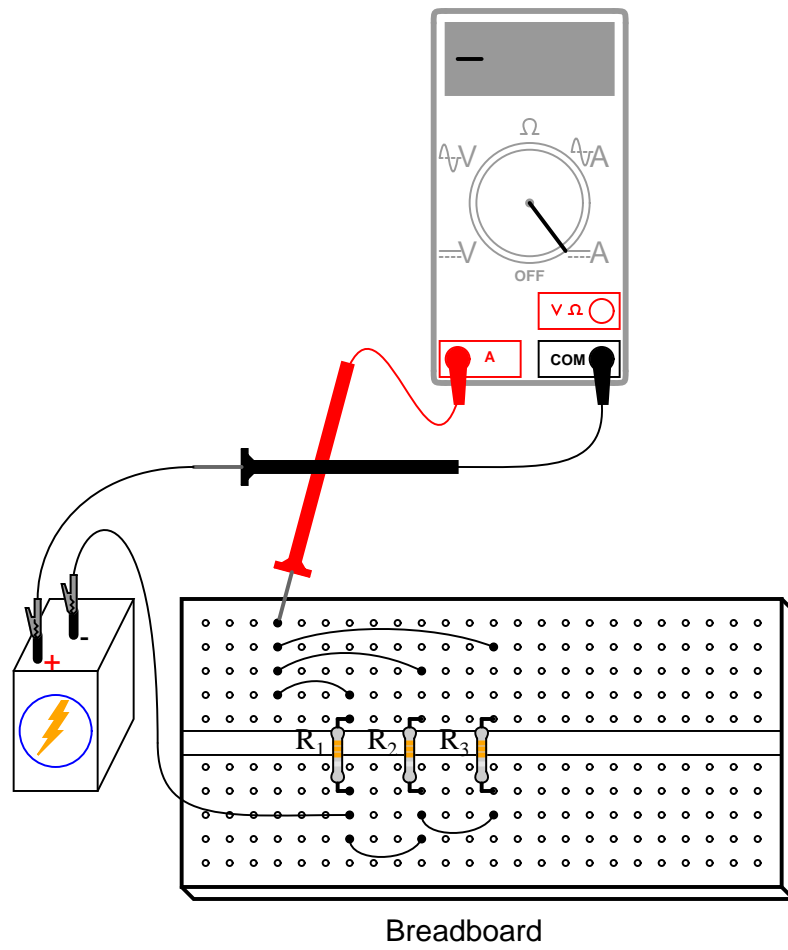

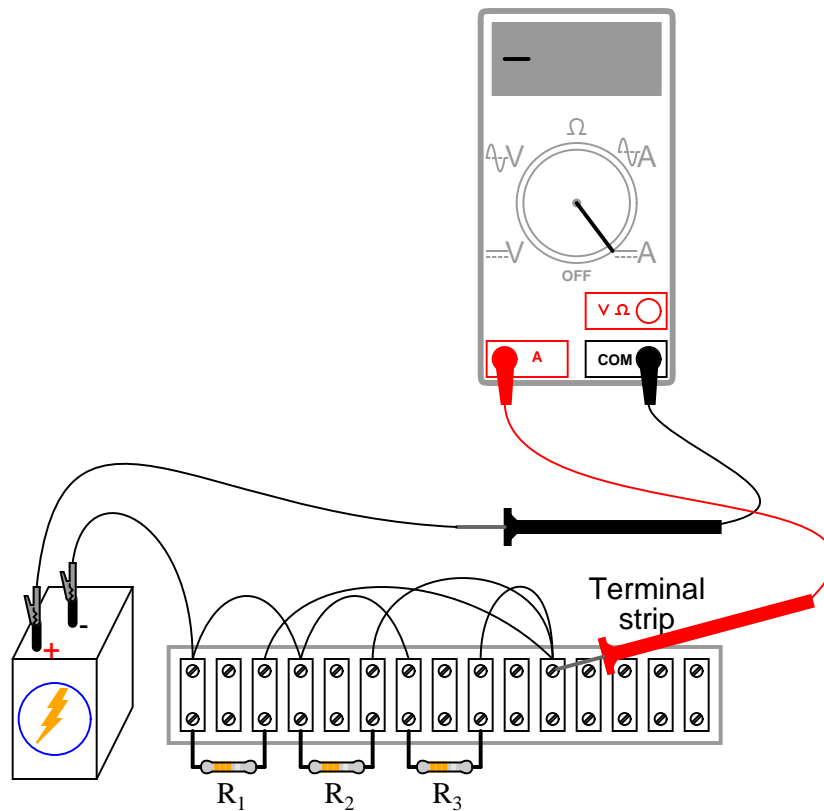

Note both the magnitude and the sign of the current as indicated by the ammeter. Add this figure (algebraically) to the three resistor currents. What do you notice about the result that is similar to the Kirchhoff's Voltage Law experiment? Kirchhoff's Current Law is to currents "summing" at a point (node) in a circuit, just as Kirchhoff's Voltage Law is to voltages adding in a series loop: in both cases, the algebraic sum is equal to zero.

This Law is also very useful in the mathematical analysis of circuits. Along with Kirchhoff's Voltage Law, it allows us to generate equations describing several variables in a circuit, which may then be solved using a variety of mathematical techniques.

Now consider the four current measurements as all positive numbers: the first three representing the current through each resistor, and the fourth representing total circuit current as a positive sum of the three "branch" currents. Each resistor (branch) current is a fraction, or percentage, of the total current. This is why a parallel resistor circuit is often called a *current divider*.

Disconnect the battery from the rest of the circuit, and measure resistance across the parallel resistors. You may read total resistance across *any* of the individual resistors' terminals and obtain the same indication: it will be a value less than any of the individual resistor values. This is often surprising to new students of electricity, that you read the exact same (total) resistance figure when connecting an ohmmeter across *any one* of a set of parallel-connected resistors. It makes sense, though, if you consider the points in a parallel circuit in terms of electrical commonality. All parallel components are connected between two sets of electrically

common points. Since the meter cannot distinguish between points common to each other by way of direct connection, to read resistance across one resistor is to read the resistance of them all. The same is true for voltage, which is why battery voltage could be read across any one of the resistors as easily as it could be read across the battery terminals directly.

If you divide the battery voltage (previously measured) by this total resistance figure, you should obtain a figure for total current ($I=E/R$) closely matching the measured figure.

The ratio of resistor current to total current is the same as the ratio of total resistance to individual resistance. For example, if a 10 k Ω resistor is part of a current divider circuit with a total resistance of 1 k Ω , that resistor will conduct 1/10 of the total current, whatever value that current total happens to be.

COMPUTER SIMULATION

Schematic with SPICE node numbers:

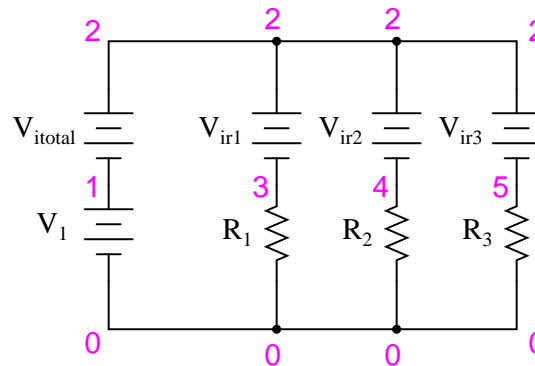

Ammeters in SPICE simulations are actually zero-voltage sources inserted in the paths of electron flow. You will notice the voltage sources V_{ir1} , V_{ir2} , and V_{ir3} are set to 0 volts in the netlist. When electrons enter the negative side of one of these "dummy" batteries and out the positive, the battery's current indication will be a positive number. In other words, these 0-volt sources are to be regarded as ammeters with the red probe on the long-line side of the battery symbol and the black probe on the short-line side.

Netlist (make a text file containing the following text, verbatim):

```
Current divider
v1 1 0
r1 3 0 2k
r2 4 0 3k
r3 5 0 5k
vitotal 2 1 dc 0
vir1 2 3 dc 0
vir2 2 4 dc 0
vir3 2 5 dc 0
.dc v1 6 6 1
.print dc i(vitotal) i(vir1) i(vir2) i(vir3)
.end
```

When run, SPICE will print a line of text containing four current figures, the first current representing the total as a negative quantity, and the other three representing currents for resistors R_1 , R_2 , and R_3 . When algebraically added, the one negative figure and the three positive figures will form a sum of zero, as described by Kirchhoff's Current Law.

3.6 Potentiometer as a voltage divider

PARTS AND MATERIALS

- Two 6-volt batteries
- Carbon pencil "lead" for a mechanical-style pencil
- Potentiometer, single turn, 5 k Ω to 50 k Ω , linear taper (Radio Shack catalog # 271-1714 through 271-1716)
- Potentiometer, multi turn, 1 k Ω to 20 k Ω , (Radio Shack catalog # 271-342, 271-343, 900-8583, or 900-8587 through 900-8590)

Potentiometers are variable voltage dividers with a shaft or slide control for setting the division ratio. They are manufactured in panel-mount as well as breadboard (printed-circuit board) mount versions. Any style of potentiometer will suffice for this experiment.

If you salvage a potentiometer from an old radio or other audio device, you will likely be getting what is called an *audio taper* potentiometer. These potentiometers exhibit a logarithmic relationship between division ratio and shaft position. By contrast, a *linear* potentiometer exhibits a direct correlation between shaft position and voltage division ratio. I highly recommend a linear potentiometer for this experiment, and for most experiments in general.

CROSS-REFERENCES

Lessons In Electric Circuits, Volume 1, chapter 6: "Divider Circuits and Kirchoff's Laws"

LEARNING OBJECTIVES

- Voltmeter use
- Ohmmeter use
- Voltage divider design and function
- How voltages add in series

SCHEMATIC DIAGRAM

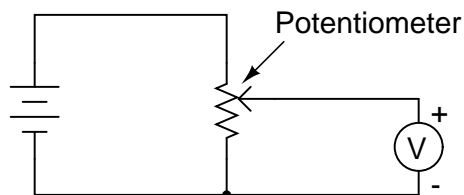

ILLUSTRATION

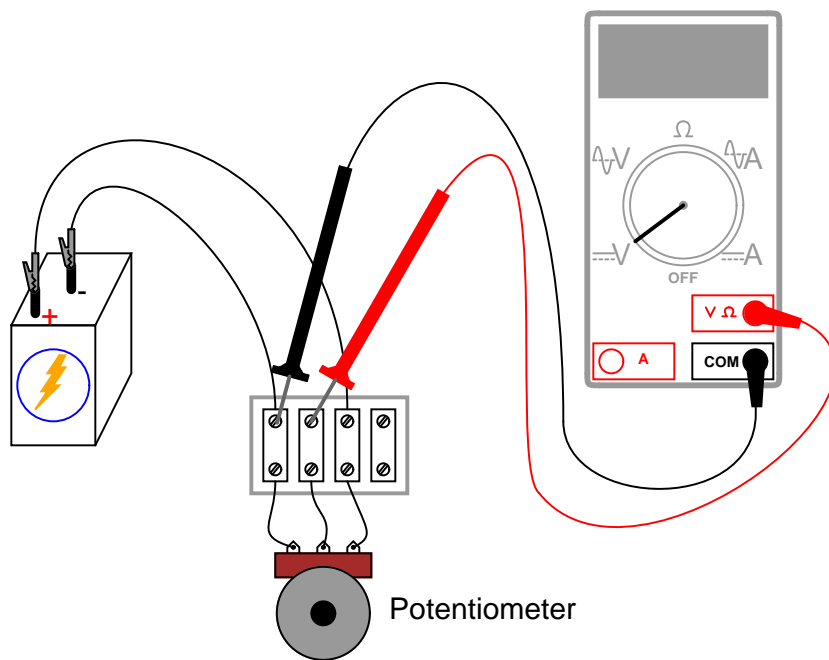
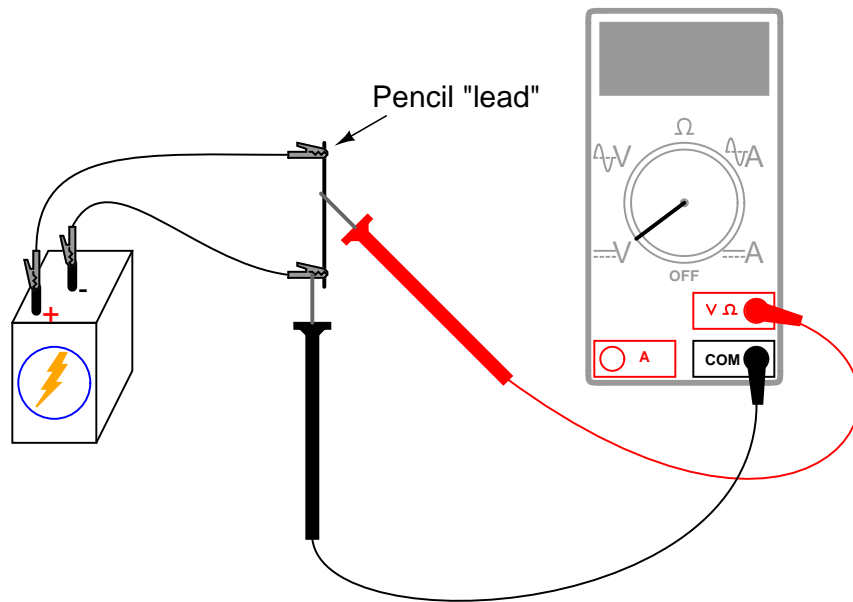

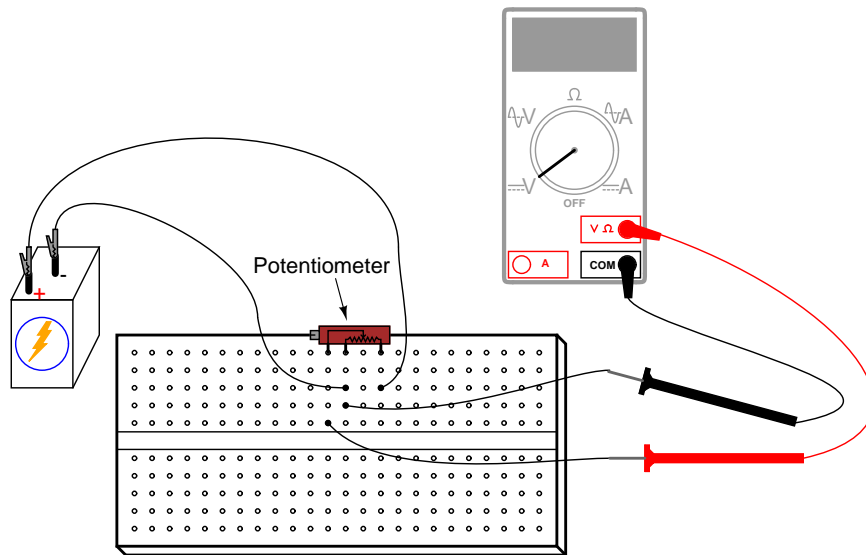

INSTRUCTIONS

Begin this experiment with the pencil "lead" circuit. Pencils use a rod made of a graphite-clay mixture, not lead (the metal), to make black marks on paper. Graphite, being a mediocre electrical conductor, acts as a resistor connected across the battery by the two alligator-clip jumper wires. Connect the voltmeter as shown and touch the red test probe to the graphite rod. Move the red probe along the length of the rod and notice the voltmeter's indication change. What probe position gives the greatest voltage indication?

Essentially, the rod acts as a *pair* of resistors, the ratio between the two resistances established by the position of the red test probe along the rod's length:

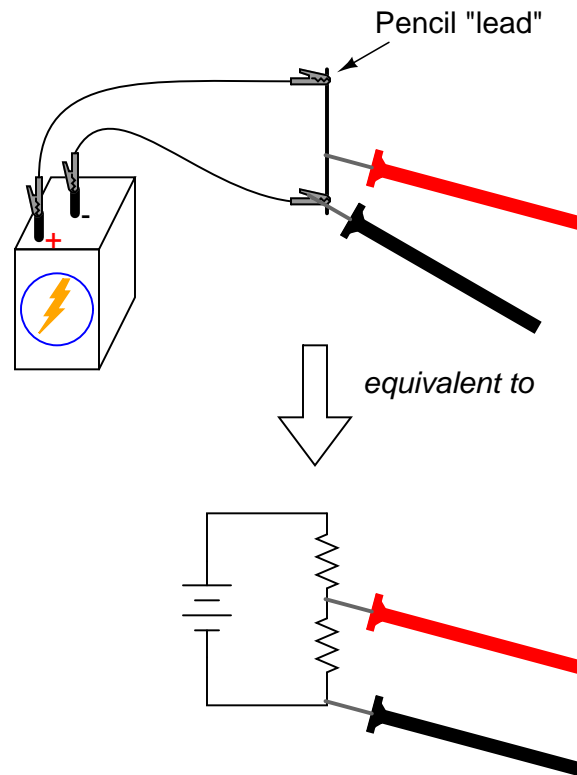

Now, change the voltmeter connection to the circuit so as to measure voltage across the "upper resistor" of the pencil lead, like this:

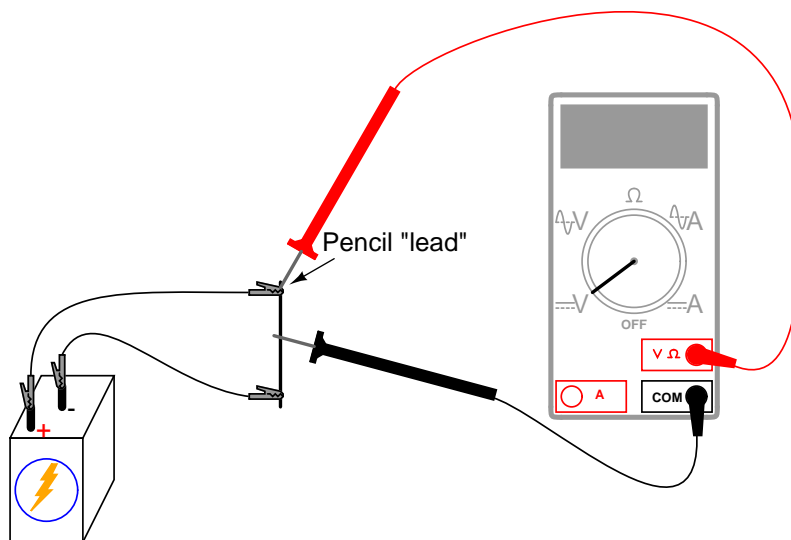

Move the black test probe position along the length of the rod, noting the voltmeter indication. Which position gives the greatest voltage drop for the meter to measure? Does this differ from the previous arrangement? Why?

Manufactured potentiometers enclose a resistive strip inside a metal or plastic housing, and provide some kind of mechanism for moving a "wiper" across the length of that resistive strip. Here is an illustration of a rotary potentiometer's construction:

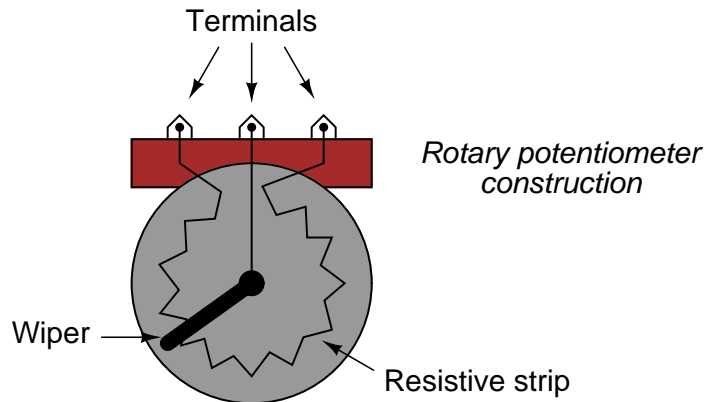

Some rotary potentiometers have a spiral resistive strip, and a wiper that moves axially as it rotates, so as to require multiple turns of the shaft to drive the wiper from one end of the potentiometer's range to the other. Multi-turn potentiometers are used in applications where precise setting is important.

Linear potentiometers also contain a resistive strip, the only difference being the wiper's direction of travel. Some linear potentiometers use a slide mechanism to move the wiper, while others a screw, to facilitate multiple-turn operation:

Linear potentiometer construction

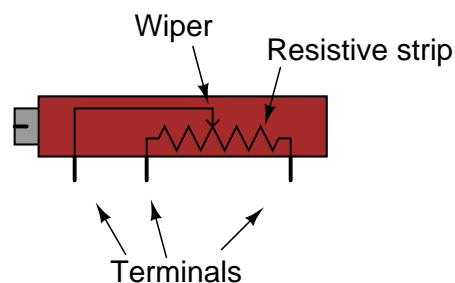

It should be noted that not all linear potentiometers have the same pin assignments. On some, the middle pin is the wiper.

Set up a circuit using a manufactured potentiometer, not the "home-made" one made from a pencil lead. You may use any form of construction that is convenient.

Measure battery voltage while powering the potentiometer, and make note of this voltage figure on paper. Measure voltage between the wiper and the potentiometer end connected to the negative (-) side of the battery. Adjust the potentiometer mechanism until the voltmeter

registers exactly $1/3$ of total voltage. For a 6-volt battery, this will be approximately 2 volts.

Now, connect two batteries in a series-aiding configuration, to provide approximately 12 volts across the potentiometer. Measure the total battery voltage, and then measure the voltage between the same two points on the potentiometer (wiper and negative side). Divide the potentiometer's measured output voltage by the measured total voltage. The quotient should be $1/3$, the same voltage division ratio as was set previously:

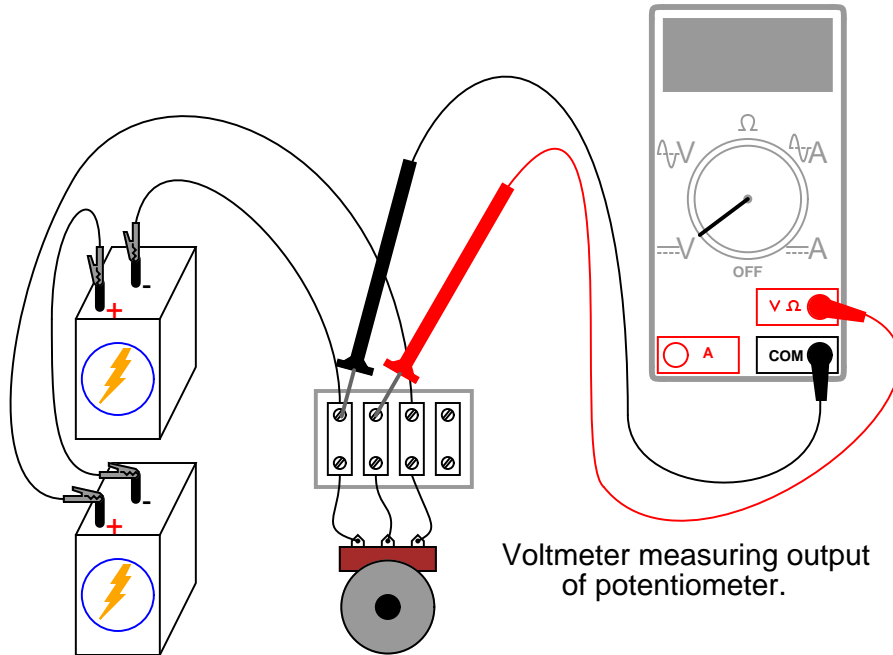

3.7 Potentiometer as a rheostat

PARTS AND MATERIALS

- 6 volt battery
- Potentiometer, single turn, 5 k Ω , linear taper (Radio Shack catalog # 271-1714)
- Small "hobby" motor, permanent-magnet type (Radio Shack catalog # 273-223 or equivalent)

For this experiment, you will need a relatively low-value potentiometer, certainly not more than 5 k Ω .

CROSS-REFERENCES

Lessons In Electric Circuits, Volume 1, chapter 2: "Ohm's Law"

LEARNING OBJECTIVES

- Rheostat use
- Wiring a potentiometer as a rheostat
- Simple motor speed control
- Use of voltmeter over ammeter to verify a continuous circuit

SCHEMATIC DIAGRAM

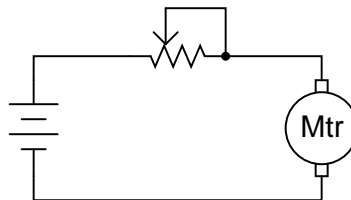

ILLUSTRATION

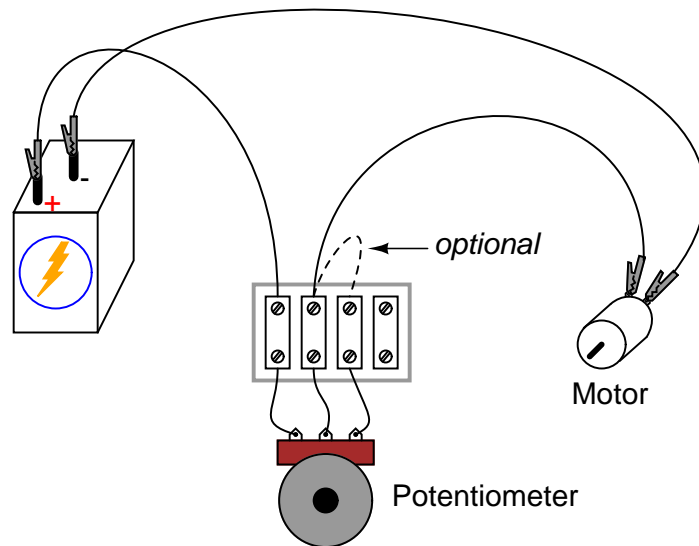

INSTRUCTIONS

Potentiometers find their most sophisticated application as voltage dividers, where shaft position determines a specific voltage division ratio. However, there are applications where we don't necessarily need a variable voltage divider, but merely a variable resistor: a two-terminal device. Technically, a variable resistor is known as a *rheostat*, but potentiometers can be made to function as rheostats quite easily.

In its simplest configuration, a potentiometer may be used as a rheostat by simply using the wiper terminal and one of the other terminals, the third terminal left unconnected and unused:

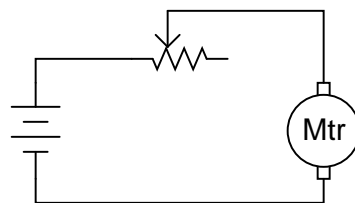

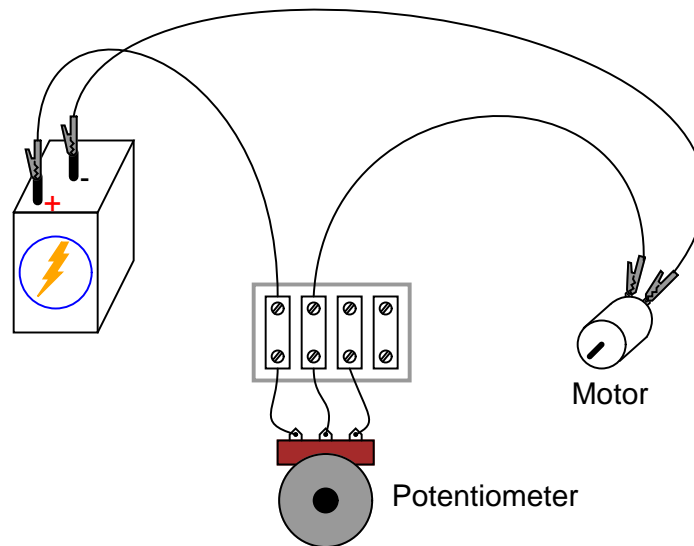

Moving the potentiometer control in the direction that brings the wiper closest to the other used terminal results in a lower resistance. The direction of motion required to increase or decrease resistance may be changed by using a different set of terminals:

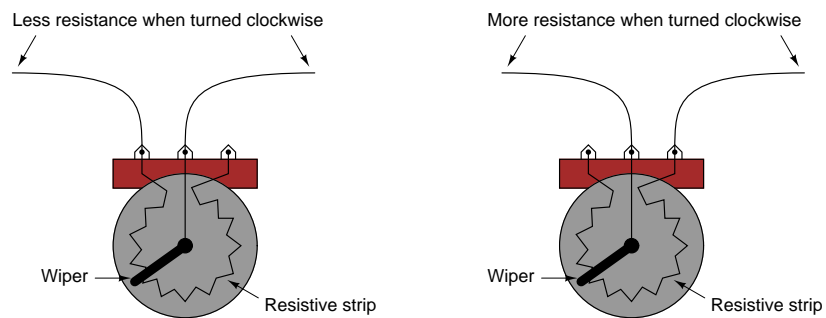

Be careful, though, that you don't use the two outer terminals, as this will result in *no change in resistance* as the potentiometer shaft is turned. In other words, it will no longer function as a *variable* resistance:

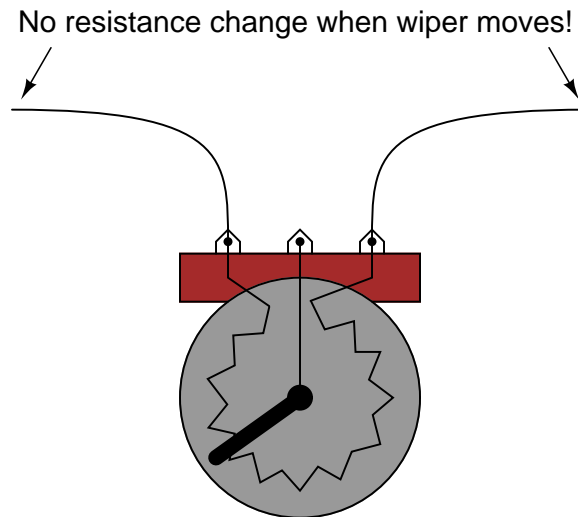

Build the circuit as shown in the schematic and illustration, using just two terminals on the potentiometer, and see how motor speed may be controlled by adjusting shaft position. Experiment with different terminal connections on the potentiometer, noting the changes in motor speed control. If your potentiometer has a high resistance (as measured between the two outer terminals), the motor might not move at all until the wiper is brought very close to the connected outer terminal.

As you can see, motor speed may be made variable using a series-connected rheostat to change total circuit resistance and limit total current. This simple method of motor speed control, however, is inefficient, as it results in substantial amounts of power being dissipated (wasted) by the rheostat. A much more efficient means of motor control relies on fast "pulsing" of power to the motor, using a high-speed switching device such as a *transistor*. A similar method of power control is used in household light "dimmer" switches. Unfortunately, these techniques are much too sophisticated to explore at this point in the experiments.

When a potentiometer is used as a rheostat, the "unused" terminal is often connected to the wiper terminal, like this:

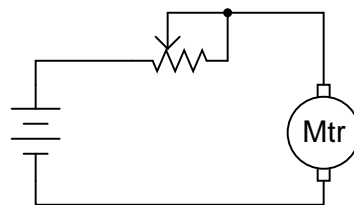

At first, this seems rather pointless, as it has no impact on resistance control. You may verify this fact for yourself by inserting another wire in your circuit and comparing motor behavior before and after the change:

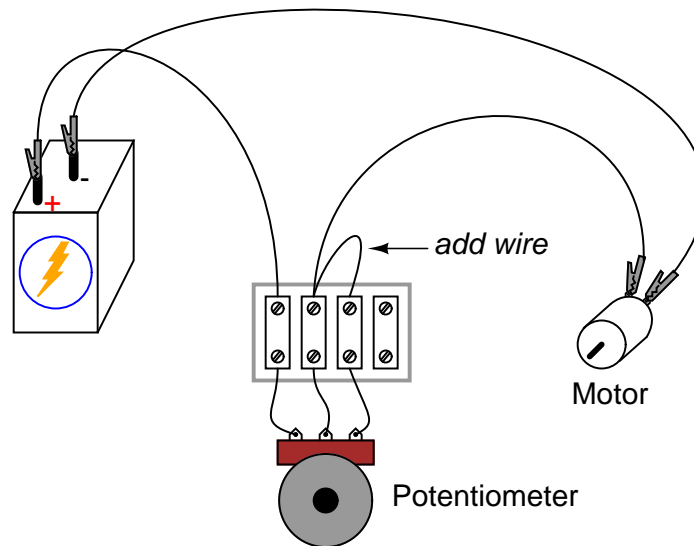

If the potentiometer is in good working order, this additional wire makes no difference whatsoever. However, if the wiper ever loses contact with the resistive strip inside the potentiometer, this connection ensures the circuit does not completely open: that there will still be a resistive path for current through the motor. In some applications, this may be an important. Old potentiometers tend to suffer from intermittent losses of contact between the wiper and the resistive strip, and if a circuit cannot tolerate the complete loss of continuity (infinite resistance) created by this condition, that "extra" wire provides a measure of protection by maintaining circuit continuity.

You may simulate such a wiper contact "failure" by disconnecting the potentiometer's middle terminal from the terminal strip, measuring voltage across the motor to ensure there is still power getting to it, however small:

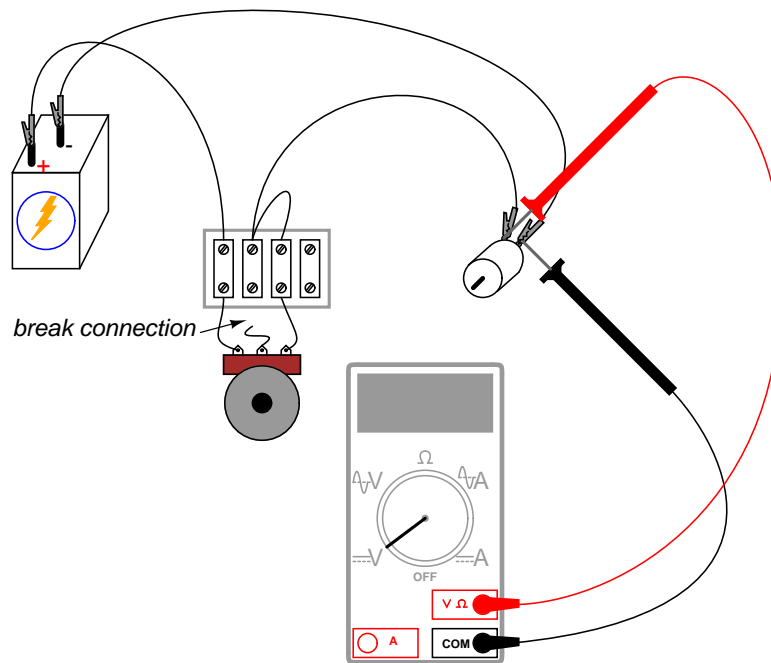

It would have been valid to measure circuit current instead of motor voltage to verify a completed circuit, but this is a safer method because it does not involve breaking the circuit to insert an ammeter in series. Whenever an ammeter is used, there is risk of causing a short circuit by connecting it across a substantial voltage source, possibly resulting in instrument damage or personal injury. Voltmeters lack this inherent safety risk, and so whenever a voltage measurement may be made instead of a current measurement to verify the same thing, it is the wiser choice.

3.8 Precision potentiometer

PARTS AND MATERIALS

- Two single-turn, linear-taper potentiometers, 5 k Ω each (Radio Shack catalog # 271-1714)
- One single-turn, linear-taper potentiometer, 50 k Ω (Radio Shack catalog # 271-1716)
- Plastic or metal mounting box
- Three "banana" jack style binding posts, or other terminal hardware, for connection to potentiometer circuit (Radio Shack catalog # 274-662 or equivalent)

This is a project useful to those who want a precision potentiometer without spending a lot of money. Ordinarily, multi-turn potentiometers are used to obtain precise voltage division ratios, but a cheaper alternative exists using multiple, single-turn (sometimes called "3/4-turn") potentiometers connected together in a compound divider network.

Because this is a useful project, I recommend building it in permanent form using some form of project enclosure. Suppliers such as Radio Shack offer nice project boxes, but boxes purchased at a general hardware store are much less expensive, if a bit ugly. The ultimate in low cost for a new box are the plastic boxes sold as light switch and receptacle boxes for household electrical wiring.

"Banana" jacks allow for the temporary connection of test leads and jumper wires equipped with matching "banana" plug ends. Most multimeter test leads have this style of plug for insertion into the meter jacks. Banana plugs are so named because of their oblong appearance formed by spring steel strips, which maintain firm contact with the jack walls when inserted. Some banana jacks are called *binding posts* because they also allow plain wires to be firmly attached. Binding posts have screw-on sleeves that fit over a metal post. The sleeve is used as a nut to secure a wire wrapped around the post, or inserted through a perpendicular hole drilled through the post. A brief inspection of any binding post will clarify this verbal description.

CROSS-REFERENCES

Lessons In Electric Circuits, Volume 1, chapter 6: "Divider Circuits and Kirchhoff's Laws"

LEARNING OBJECTIVES

- Soldering practice
- Potentiometer function and operation

SCHEMATIC DIAGRAM

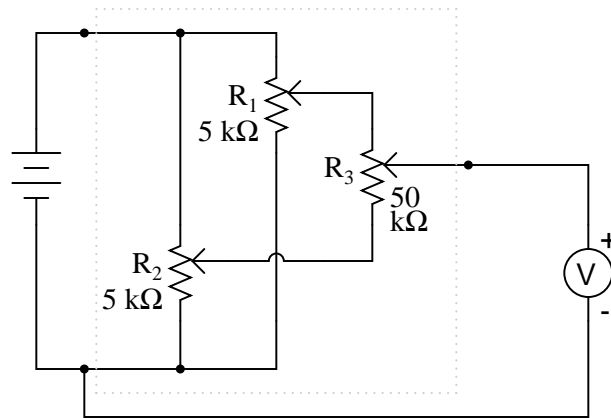
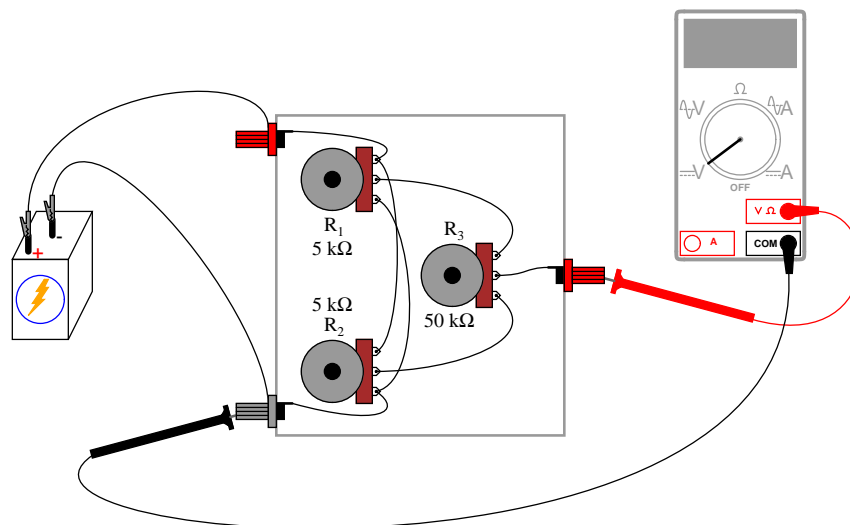
**ILLUSTRATION****INSTRUCTIONS**

It is essential that the connecting wires be *soldered* to the potentiometer terminals, not twisted or taped. Since potentiometer action is dependent on resistance, the resistance of all wiring connections must be carefully controlled to a bare minimum. Soldering ensures a condition of low resistance between joined conductors, and also provides very good mechanical strength for the connections.

When the circuit is assembled, connect a 6-volt battery to the outer two binding posts. Connect a voltmeter between the "wiper" post and the battery's negative (-) terminal. This voltmeter will measure the "output" of the circuit.

The circuit works on the principle of compressed range: the voltage output range of this circuit available by adjusting potentiometer R_3 is restricted between the limits set by potentiometers R_1 and R_2 . In other words, if R_1 and R_2 were set to output 5 volts and 3 volts,

respectively, from a 6-volt battery, the range of output voltages obtainable by adjusting R_3 would be restricted from 3 to 5 volts for the full rotation of that potentiometer. If only a single potentiometer were used instead of this three-potentiometer circuit, full rotation would produce an output voltage from 0 volts to full battery voltage. The "range compression" afforded by this circuit allows for more precise voltage adjustment than would be normally obtainable using a single potentiometer.

Operating this potentiometer network is more complex than using a single potentiometer. To begin, turn the R_3 potentiometer fully clockwise, so that its wiper is in the full "up" position as referenced to the schematic diagram (electrically "closest" to R_1 's wiper terminal). Adjust potentiometer R_1 until the upper voltage limit is reached, as indicated by the voltmeter.

Turn the R_3 potentiometer fully counter-clockwise, so that its wiper is in the full "down" position as referenced to the schematic diagram (electrically "closest" to R_2 's wiper terminal). Adjust potentiometer R_2 until the lower voltage limit is reached, as indicated by the voltmeter.

When either the R_1 or the R_2 potentiometer is adjusted, it interferes with the prior setting of the other. In other words, if R_1 is initially adjusted to provide an upper voltage limit of 5.000 volts from a 6 volt battery, and then R_2 is adjusted to provide some lower limit voltage different from what it was before, R_1 will no longer be set to 5.000 volts.

To obtain precise upper and lower voltage limits, turn R_3 fully clockwise to read and adjust the voltage of R_1 , then turn R_3 fully counter-clockwise to read and adjust the voltage of R_2 , repeating as necessary.

Technically, this phenomenon of one adjustment affecting the other is known as *interaction*, and it is usually undesirable due to the extra effort required to set and re-set the adjustments. The reason that R_1 and R_2 were specified as 10 times less resistance than R_3 is to minimize this effect. If all three potentiometers were of equal resistance value, the interaction between R_1 and R_2 would be more severe, though manageable with patience. Bear in mind that the upper and lower voltage limits need not be set precisely in order for this circuit to achieve its goal of increased precision. So long as R_3 's adjustment range is compressed to some lesser value than full battery voltage, we will enjoy greater precision than a single potentiometer could provide.

Once the upper and lower voltage limits have been set, potentiometer R_3 may be adjusted to produce an output voltage anywhere between those limits.

3.9 Rheostat range limiting

PARTS AND MATERIALS

- Several $10\text{ k}\Omega$ resistors
- One $10\text{ k}\Omega$ potentiometer, linear taper (Radio Shack catalog # 271-1715)

CROSS-REFERENCES

Lessons In Electric Circuits, Volume 1, chapter 5: "Series and Parallel Circuits"

Lessons In Electric Circuits, Volume 1, chapter 7: "Series-Parallel Combination Circuits"

Lessons In Electric Circuits, Volume 1, chapter 8: "DC Metering Circuits"

LEARNING OBJECTIVES

- Series-parallel resistances
- Calibration theory and practice

SCHEMATIC DIAGRAM

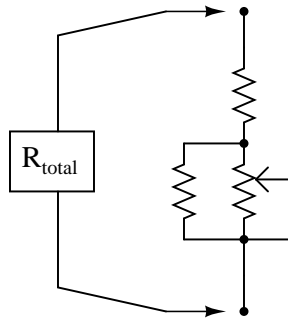

ILLUSTRATION

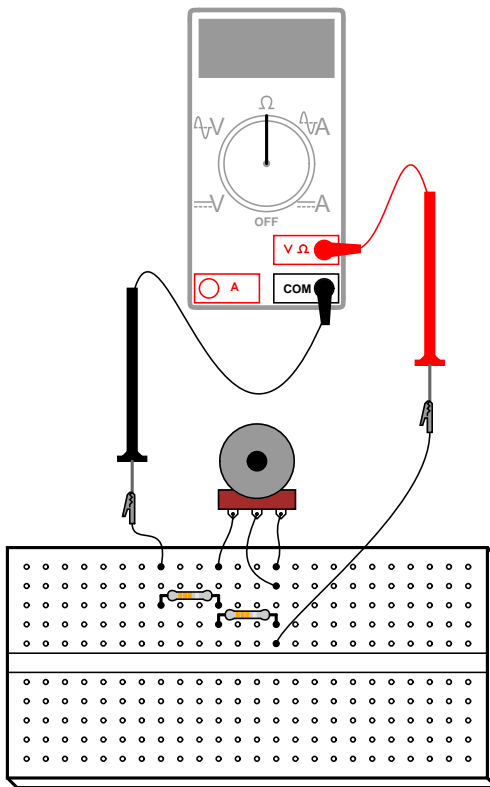

INSTRUCTIONS

This experiment explores the different resistance ranges obtainable from combining fixed-value resistors with a potentiometer connected as a rheostat. To begin, connect a 10 k Ω potentiometer as a rheostat with no other resistors connected. Adjusting the potentiometer through its full range of travel should result in a resistance that varies smoothly from 0 Ω to 10,000 Ω :

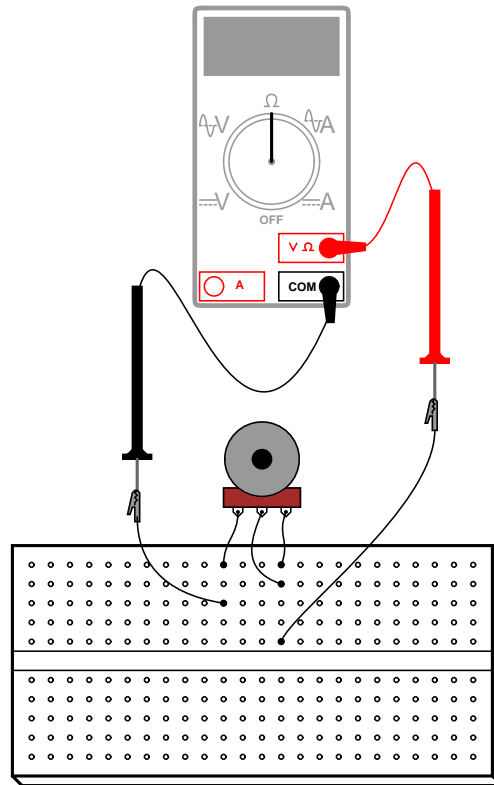

Suppose we wanted to elevate the lower end of this resistance range so that we had an adjustable range from $10 \text{ k}\Omega$ to $20 \text{ k}\Omega$ with a full sweep of the potentiometer's adjustment. This could be easily accomplished by adding a $10 \text{ k}\Omega$ resistor in *series* with the potentiometer. Add one to the circuit as shown and re-measure total resistance while adjusting the potentiometer:

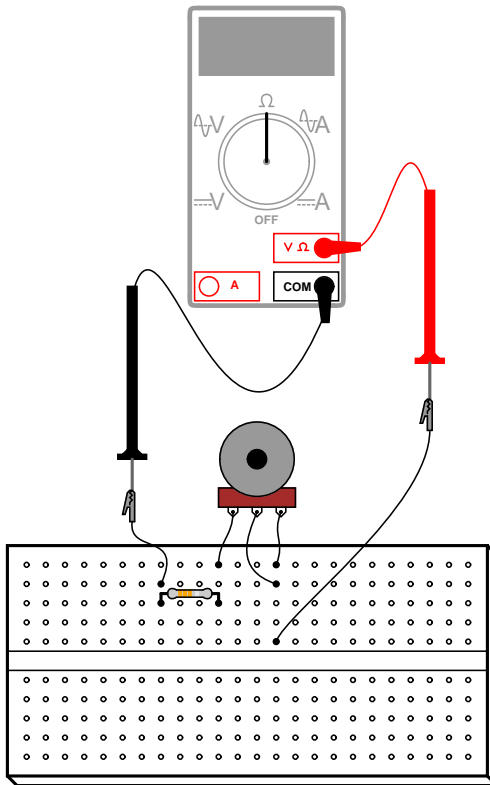

A shift in the low end of an adjustment range is called a *zero calibration*, in metrological terms. With the addition of a series $10\text{ k}\Omega$ resistor, the "zero point" was shifted upward by $10,000\ \Omega$. The difference between high and low ends of a range – called the *span* of the circuit – has not changed, though: a range of $10\text{ k}\Omega$ to $20\text{ k}\Omega$ has the same $10,000\ \Omega$ span as a range of $0\ \Omega$ to $10\text{ k}\Omega$. If we wish to shift the span of this rheostat circuit as well, we must change the range of the potentiometer itself. We could replace the potentiometer with one of another value, or we could simulate a lower-value potentiometer by placing a resistor in *parallel* with it, diminishing its maximum obtainable resistance. This will decrease the span of the circuit from $10\text{ k}\Omega$ to something less.

Add a $10\text{ k}\Omega$ resistor in parallel with the potentiometer, to reduce the span to one-half of its former value: from $10\text{ k}\Omega$ to $5\text{ k}\Omega$. Now the calibrated resistance range of this circuit will be $10\text{ k}\Omega$ to $15\text{ k}\Omega$:

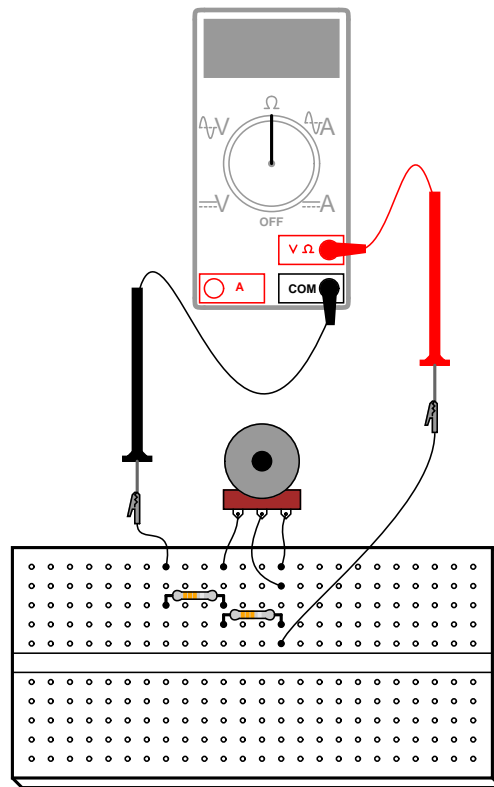

There is nothing we can do to *increase* the span of this rheostat circuit, short of replacing the potentiometer with another of greater total resistance. Adding resistors in parallel can only decrease the span. However, there is no such restriction with calibrating the zero point of this circuit, as it began at $0\ \Omega$ and may be made as great as we wish by adding resistance in series.

A multitude of resistance ranges may be obtained using only $10\ \text{k}\Omega$ fixed-value resistors, if we are creative with series-parallel combinations of them. For instance, we can create a range of $7.5\ \text{k}\Omega$ to $10\ \text{k}\Omega$ by building the following circuit:

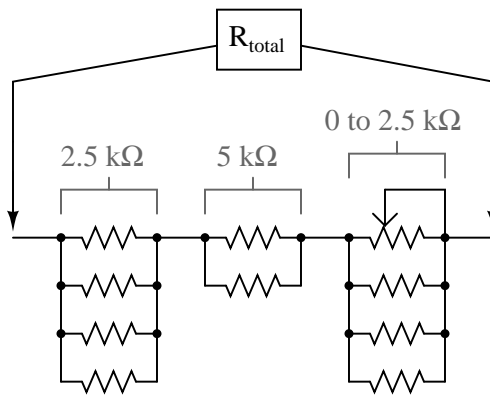

All resistors = $10\text{ k}\Omega$

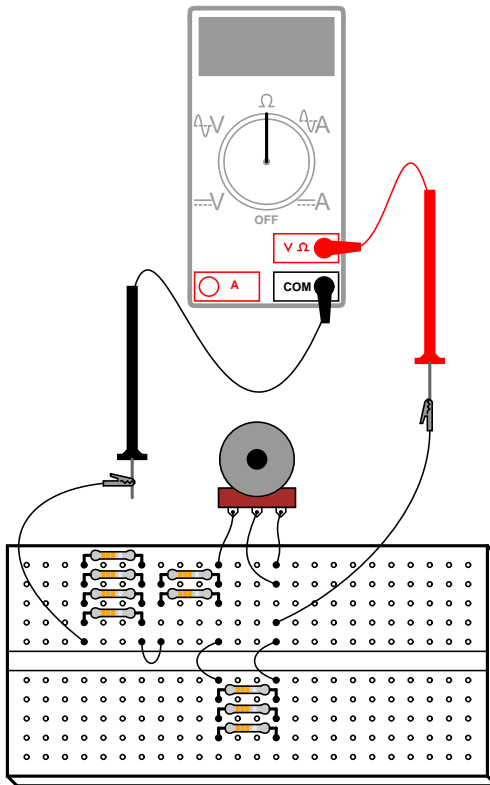

Creating a custom resistance range from fixed-value resistors and a potentiometer is a very useful technique for producing precise resistances required for certain circuits, especially meter circuits. In many electrical instruments – multimeters especially – resistance is the determining factor for the instrument's range of measurement. If an instrument's internal resistance values are not precise, neither will its indications be. Finding a fixed-value resistor

of just the right resistance for placement in an instrument circuit design is unlikely, so custom resistance "networks" may need to be built to provide the desired resistance. Having a potentiometer as part of the resistor network provides a means of correction if the network's resistance should "drift" from its original value. Designing the network for minimum span ensures that the potentiometer's effect will be small, so that precise adjustment is possible and so that accidental movement of its mechanism will not result in severe calibration errors.

Experiment with different resistor "networks" and note the effects on total resistance range.

3.10 Thermoelectricity

PARTS AND MATERIALS

- Length of bare (uninsulated) copper wire
- Length of bare (uninsulated) iron wire
- Candle
- Ice cubes

Iron wire may be obtained from a hardware store. If some cannot be found, aluminum wire also works.

CROSS-REFERENCES

Lessons In Electric Circuits, Volume 1, chapter 9: "Electrical Instrumentation Signals"

LEARNING OBJECTIVES

- Thermocouple function and purpose

SCHEMATIC DIAGRAM



ILLUSTRATION

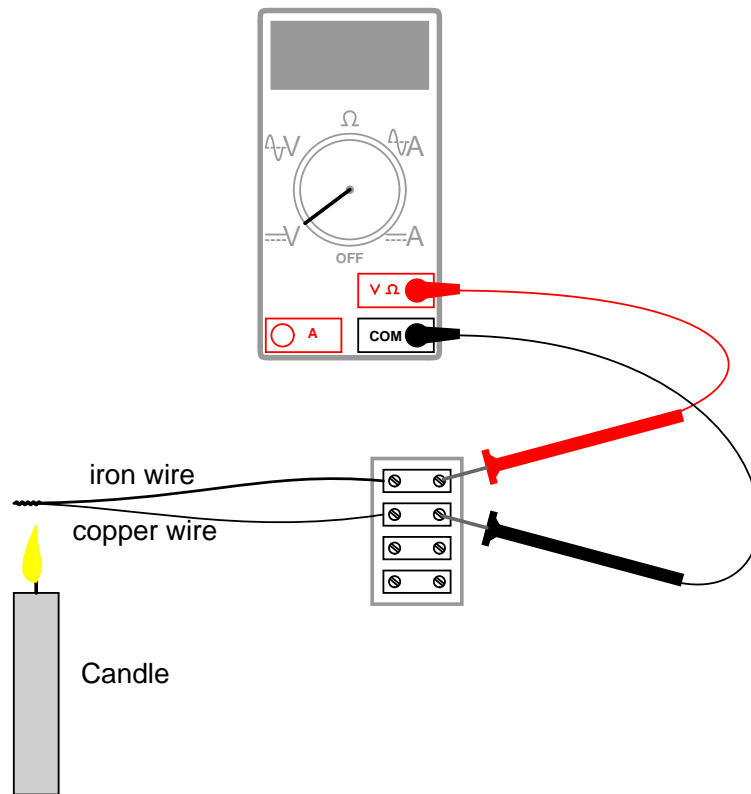

INSTRUCTIONS

Twist one end of the iron wire together with one end of the copper wire. Connect the free ends of these wires to respective terminals on a terminal strip. Set your voltmeter to its most sensitive range and connect it to the terminals where the wires attach. The meter should indicate nearly zero voltage.

What you have just constructed is a *thermocouple*: a device which generates a small voltage proportional to the temperature difference between the tip and the meter connection points. When the tip is at a temperature equal to the terminal strip, there will be no voltage produced, and thus no indication seen on the voltmeter.

Light a candle and insert the twisted-wire tip into the flame. You should notice an indication on your voltmeter. Remove the thermocouple tip from the flame and let cool until the voltmeter indication is nearly zero again. Now, touch the thermocouple tip to an ice cube and note the voltage indicated by the meter. Is it a greater or lesser magnitude than the indication obtained with the flame? How does the polarity of this voltage compare with that generated by the flame?

After touching the thermocouple tip to the ice cube, warm it by holding it between your fingers. It may take a short while to reach body temperature, so be patient while observing the voltmeter's indication.

A thermocouple is an application of the *Seebeck effect*: the production of a small voltage proportional to a temperature gradient along the length of a wire. This voltage is dependent upon the magnitude of the temperature difference and the type of wire. Directly measuring the Seebeck voltage produced along a length of continuous wire from a temperature gradient is quite difficult, and so will not be attempted in this experiment.

Thermocouples, being made of two dissimilar metals joined at one end, produce a voltage proportional to the temperature of the junction. The temperature gradient along both wires resulting from a constant temperature at the junction produces different Seebeck voltages along those wires' lengths, because the wires are made of different metals. The resultant voltage between the two free wire ends is the *difference* between the two Seebeck voltages:

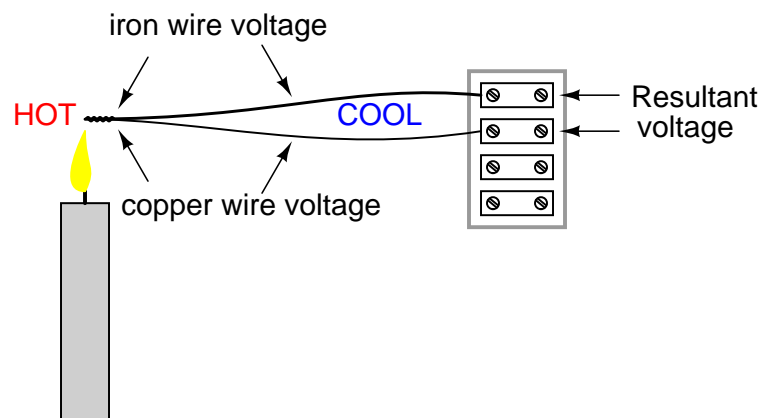

Thermocouples are widely used as temperature-sensing devices because the mathematical relationship between temperature difference and resultant voltage is both repeatable and fairly linear. By measuring voltage, it is possible to infer temperature. Different ranges of temperature measurement are possible by selecting different metal pairs to be joined together.

3.11 Make your own multimeter

PARTS AND MATERIALS

- Sensitive meter movement (Radio Shack catalog # 22-410)
- Selector switch, single-pole, multi-throw, break-before-make (Radio Shack catalog # 275-1386 is a 2-pole, 6-position unit that works well)
- Multi-turn potentiometers, PCB mount (Radio Shack catalog # 271-342 and 271-343 are 15-turn, 1 k Ω and 10 k Ω "trimmer" units, respectively)
- Assorted resistors, preferably high-precision metal film or wire-wound types (Radio Shack catalog # 271-309 is an assortment of metal-film resistors, +/- 1% tolerance)
- Plastic or metal mounting box
- Three "banana" jack style binding posts, or other terminal hardware, for connection to potentiometer circuit (Radio Shack catalog # 274-662 or equivalent)

The most important and expensive component in a meter is the *movement*: the actual needle-and-scale mechanism whose task it is to translate an electrical current into mechanical displacement where it may be visually interpreted. The ideal meter movement is physically large (for ease of viewing) and as sensitive as possible (requires minimal current to produce full-scale deflection of the needle). High-quality meter movements are expensive, but Radio Shack carries some of acceptable quality that are reasonably priced. The model recommended in the parts list is sold as a voltmeter with a 0-15 volt range, but is actually a milliammeter with a range ("multiplier") resistor included separately.

It may be cheaper to purchase an inexpensive analog meter and disassemble it for the meter movement alone. Although the thought of destroying a working multimeter in order to have parts to make your own may sound counter-productive, the goal here is *learning*, not meter function.

I cannot specify resistor values for this experiment, as these depend on the particular meter movement and measurement ranges chosen. Be sure to use high-precision fixed-value resistors rather than carbon-composition resistors. Even if you happen to find carbon-composition resistors of just the right value(s), those values will change or "drift" over time due to aging and temperature fluctuations. Of course, if you don't care about the long-term stability of this meter but are building it just for the learning experience, resistor precision matters little.

CROSS-REFERENCES

Lessons In Electric Circuits, Volume 1, chapter 8: "DC Metering Circuits"

LEARNING OBJECTIVES

- Voltmeter design and use
- Ammeter design and use
- Rheostat range limiting

- Calibration theory and practice
- Soldering practice

SCHEMATIC DIAGRAM

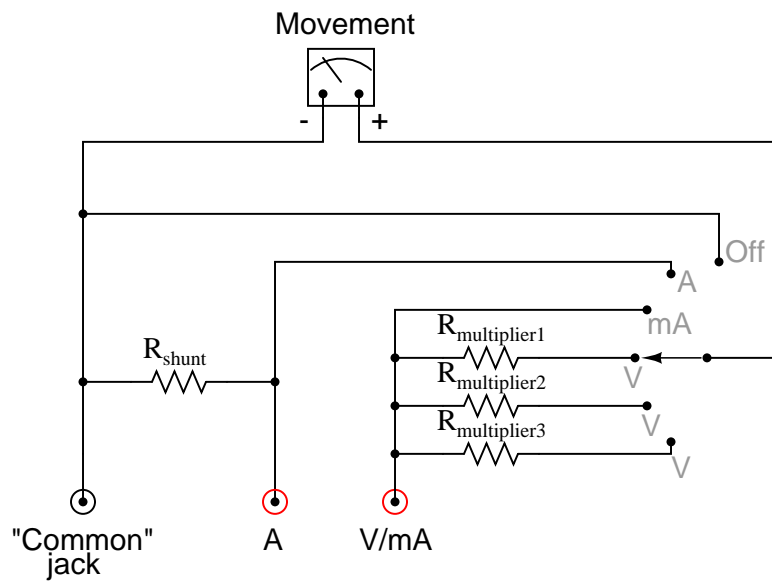

" $R_{multiplier}$ " resistors are actually rheostat networks

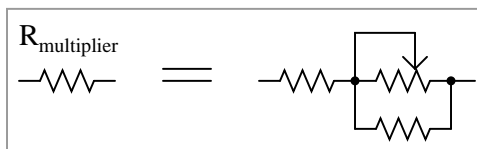

ILLUSTRATION

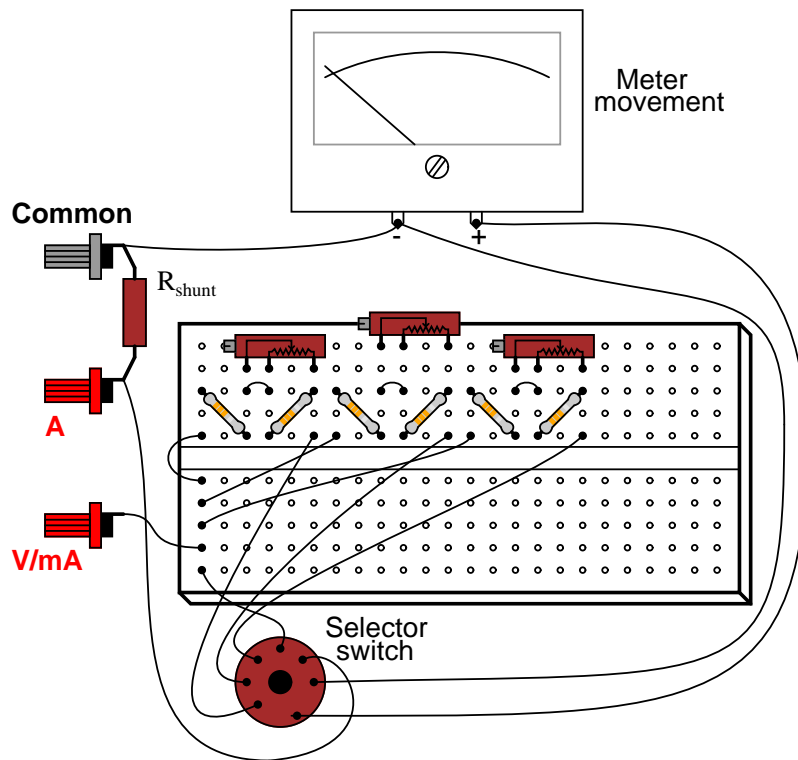

INSTRUCTIONS

First, you need to determine the characteristics of your meter movement. Most important is to know the *full scale deflection* in milliamps or microamps. To determine this, connect the meter movement, a potentiometer, battery, and digital ammeter in series. Adjust the potentiometer until the meter movement is deflected exactly to full-scale. Read the ammeter's display to find the full-scale current value:

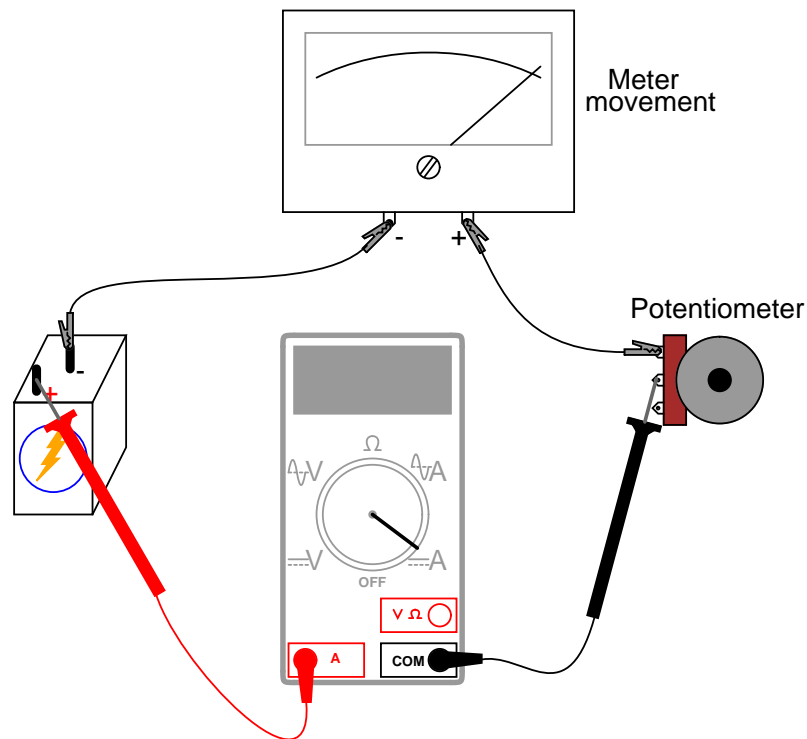

Be very careful not to apply too much current to the meter movement, as movements are very sensitive devices and easily damaged by overcurrent. Most meter movements have full-scale deflection current ratings of 1 mA or less, so choose a potentiometer value high enough to limit current appropriately, and begin testing with the potentiometer turned to maximum resistance. The lower the full-scale current rating of a movement, the more sensitive it is.

After determining the full-scale current rating of your meter movement, you must accurately measure its internal resistance. To do this, disconnect all components from the previous testing circuit and connect your digital ohmmeter across the meter movement terminals. Record this resistance figure along with the full-scale current figure obtained in the last procedure.

Perhaps the most challenging portion of this project is determining the proper range resistance values and implementing those values in the form of rheostat networks. The calculations are outlined in chapter 8 of volume 1 ("Metering Circuits"), but an example is given here. Suppose your meter movement had a full-scale rating of 1 mA and an internal resistance of 400 Ω . If we wanted to determine the necessary range resistance (" $R_{multiplier}$ ") to give this movement a range of 0 to 15 volts, we would have to divide 15 volts (total applied voltage) by 1 mA (full-scale current) to obtain the total probe-to-probe resistance of the voltmeter ($R=E/I$). For this example, that total resistance is 15 k Ω . From this total resistance figure, we subtract the movement's internal resistance, leaving 14.6 k Ω for the range resistor value. A simple rheostat network to produce 14.6 k Ω (adjustable) would be a 10 k Ω potentiometer in parallel with a 10 k Ω fixed resistor, all in series with another 10 k Ω fixed resistor:

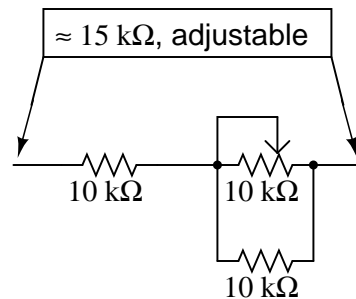

One position of the selector switch directly connects the meter movement between the black **Common** binding post and the red **V/mA** binding post. In this position, the meter is a sensitive ammeter with a range equal to the full-scale current rating of the meter movement. The far clockwise position of the switch disconnects the positive (+) terminal of the movement from either red binding post and shorts it directly to the negative (-) terminal. This protects the meter from electrical damage by isolating it from the red test probe, and it "dampens" the needle mechanism to further guard against mechanical shock.

The shunt resistor (R_{shunt}) necessary for a high-current ammeter function needs to be a low-resistance unit with a high power dissipation. You will definitely *not* be using any 1/4 watt resistors for this, unless you form a resistance network with several smaller resistors in parallel combination. If you plan on having an ammeter range in excess of 1 amp, I recommend using a thick piece of wire or even a skinny piece of sheet metal as the "resistor," suitably filed or notched to provide just the right amount of resistance.

To calibrate a home-made shunt resistor, you will need to connect the your multimeter assembly to a calibrated source of high current, or a high-current source in series with a digital ammeter for reference. Use a small metal file to shave off shunt wire thickness or to notch the sheet metal strip in small, careful amounts. The resistance of your shunt will increase with every stroke of the file, causing the meter movement to deflect more strongly. Remember that you can always approach the exact value in slower and slower steps (file strokes), but you cannot go "backward" and *decrease* the shunt resistance!

Build the multimeter circuit on a breadboard first while determining proper range resistance values, and perform all calibration adjustments there. For final construction, solder the components on to a printed-circuit board. Radio Shack sells printed circuit boards that have the same layout as a breadboard, for convenience (catalog # 276-170). Feel free to alter the component layout from what is shown.

I strongly recommend that you mount the circuit board and all components in a sturdy box, so that the meter is durably finished. Despite the limitations of this multimeter (no resistance function, inability to measure alternating current, and lower precision than most purchased analog multimeters), it is an excellent project to assist learning fundamental instrument principles and circuit function. A far more accurate and versatile multimeter may be constructed using many of the same parts if an amplifier circuit is added to it, so save the parts and pieces for a later experiment!

3.12 Sensitive voltage detector

PARTS AND MATERIALS

- High-quality "closed-cup" audio headphones
- Headphone jack: female receptacle for headphone plug (Radio Shack catalog # 274-312)
- Small step-down power transformer (Radio Shack catalog # 273-1365 or equivalent, using the 6-volt secondary winding tap)
- Two 1N4001 rectifying diodes (Radio Shack catalog # 276-1101)
- 1 k Ω resistor
- 100 k Ω potentiometer (Radio Shack catalog # 271-092)
- Two "banana" jack style binding posts, or other terminal hardware, for connection to potentiometer circuit (Radio Shack catalog # 274-662 or equivalent)
- Plastic or metal mounting box

Regarding the headphones, the higher the "sensitivity" rating in decibels (dB), the better, but listening is believing: if you're serious about building a detector with maximum sensitivity for small electrical signals, you should try a few different headphone models at a high-quality audio store and "listen" for which ones produce an audible sound for the *lowest* volume setting on a radio or CD player. Beware, as you could spend hundreds of dollars on a pair of headphones to get the absolute best sensitivity! Take heart, though: I've used an *old* pair of Radio Shack "Realistic" brand headphones with perfectly adequate results, so you don't need to buy the best.

A *transformer* is a device normally used with alternating current ("AC") circuits, used to convert high-voltage AC power into low-voltage AC power, and for many other purposes. It is not important that you understand its intended function in this experiment, other than it makes the headphones become more sensitive to low-current electrical signals.

Normally, the transformer used in this type of application (audio speaker impedance matching) is called an "audio transformer," with its primary and secondary windings represented by impedance values (1000 Ω : 8 Ω) instead of voltages. An audio transformer will work, but I've found small step-down power transformers of 120/6 volt ratio to be perfectly adequate for the task, cheaper (especially when taken from an old thrift-store alarm clock radio), and far more rugged.

The tolerance (precision) rating for the 1 k Ω resistor is irrelevant. The 100 k Ω potentiometer is a recommended option for incorporation into this project, as it gives the user control over the loudness for any given signal. Even though an *audio-taper* potentiometer would be appropriate for this application, it is not necessary. A *linear-taper* potentiometer works quite well.

CROSS-REFERENCES

Lessons In Electric Circuits, Volume 1, chapter 8: "DC Metering Circuits"

Lessons In Electric Circuits, Volume 1, chapter 10: "DC Network Analysis" (in regard to the Maximum Power Transfer Theorem)

Lessons In Electric Circuits, Volume 2, chapter 9: "Transformers"

Lessons In Electric Circuits, Volume 2, chapter 12: "AC Metering Circuits"

LEARNING OBJECTIVES

- Soldering practice
- Detection of extremely small electrical signals
- Using a potentiometer as a voltage divider/signal attenuator
- Using diodes to "clip" voltage at some maximum level

SCHEMATIC DIAGRAM

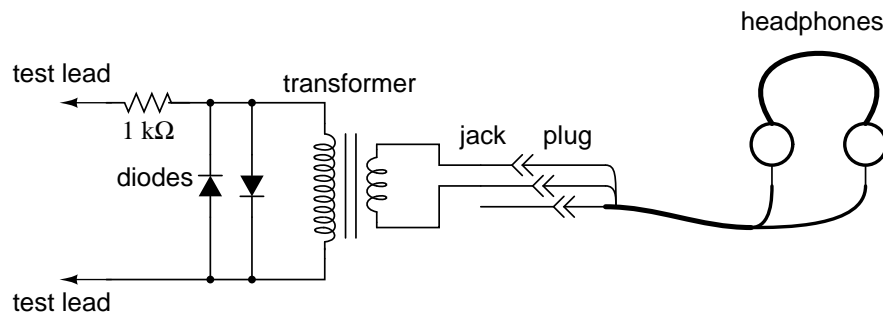

ILLUSTRATION

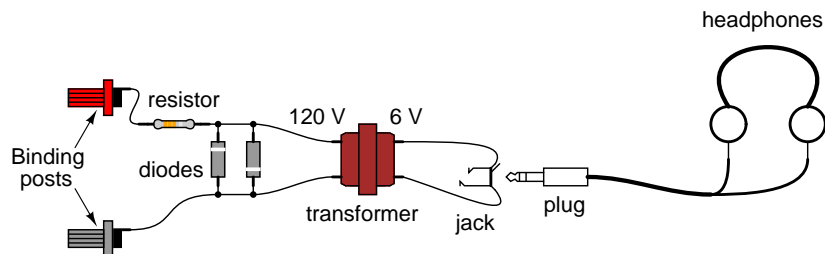

INSTRUCTIONS

The headphones, most likely being stereo units (separate left and right speakers) will have a three-contact plug. You will be connecting to only two of those three contact points. If you only have a "mono" headphone set with a two-contact plug, just connect to those two contact points. You may either connect the two stereo speakers in series or in parallel. I've found the series connection to work best, that is, to produce the most sound from a small signal:

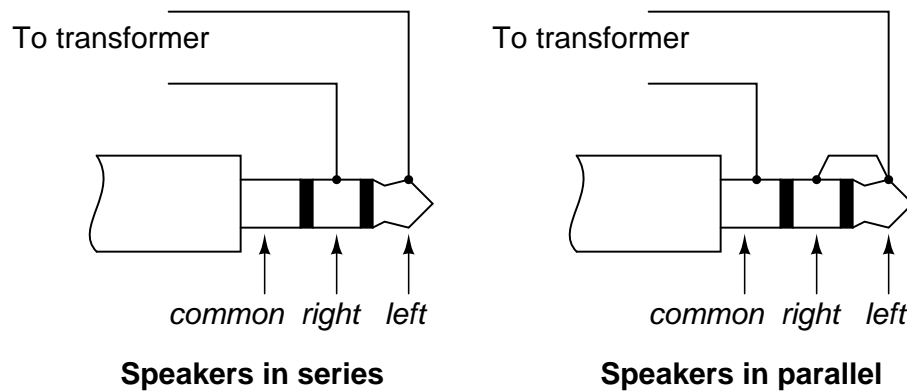

Solder all wire connections well. This detector system is extremely sensitive, and any loose wire connections in the circuit will add unwanted noise to the sounds produced by the measured voltage signal. The two diodes (arrow-like component symbols) connected in parallel with the transformer's primary winding, along with the series-connected $1\text{ k}\Omega$ resistor, work together to prevent any more than about 0.7 volts from being dropped across the primary coil of the transformer. This does one thing and one thing only: limit the amount of sound the headphones can produce. The system will work without the diodes and resistor in place, but there will be no limit to sound volume in the circuit, and the resulting sound caused by accidentally connecting the test leads across a substantial voltage source (like a battery) can be deafening!

Binding posts provide points of connection for a pair of test probes with banana-style plugs, once the detector components are mounted inside a box. You may use ordinary multimeter probes, or make your own probes with alligator clips at the ends for secure connection to a circuit.

Detectors are intended to be used for balancing bridge measurement circuits, potentiometric (null-balance) voltmeter circuits, and detect extremely low-amplitude AC ("alternating current") signals in the audio frequency range. It is a valuable piece of test equipment, especially for the low-budget experimenter without an oscilloscope. It is also valuable in that it allows you to use a different bodily sense in interpreting the behavior of a circuit.

For connection across any non-trivial source of voltage (1 volt and greater), the detector's extremely high sensitivity should be attenuated. This may be accomplished by connecting a voltage divider to the "front" of the circuit:

SCHEMATIC DIAGRAM

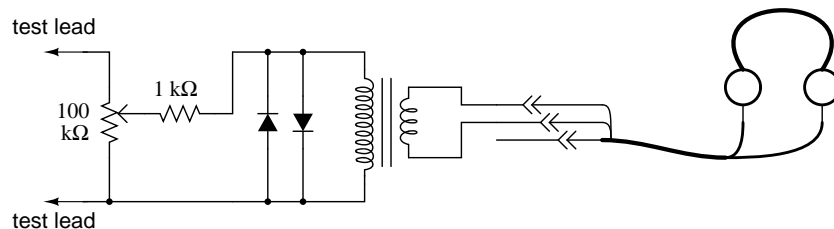

ILLUSTRATION

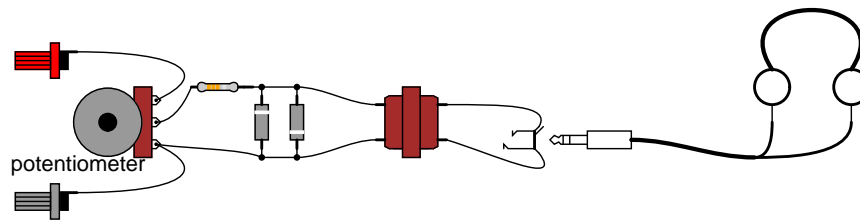

Adjust the 100 k Ω voltage divider potentiometer to about mid-range when initially sensing a voltage signal of unknown magnitude. If the sound is too loud, turn the potentiometer down and try again. If too soft, turn it up and try again. The detector produces a "click" sound whenever the test leads make or break contact with the voltage source under test. With my cheap headphones, I've been able to detect currents of less than 1/10 of a microamp ($\approx 0.1 \mu\text{A}$).

A good demonstration of the detector's sensitivity is to touch both test leads to the end of your tongue, with the sensitivity adjustment set to maximum. The voltage produced by metal-to-electrolyte contact (called *galvanic voltage*) is very small, but enough to produce soft "clicking" sounds every time the leads make and break contact on the wet skin of your tongue.

Try unplugged the headphone plug from the jack (receptacle) and similarly touching it to the end of your tongue. You should still hear soft clicking sounds, but they will be much smaller in amplitude. Headphone speakers are "low impedance" devices: they require low voltage and "high" current to deliver substantial sound power. Impedance is a measure of opposition to any and all forms of electric current, including alternating current (AC). Resistance, by comparison, is a strictly measure of opposition to *direct* current (DC). Like resistance, impedance is measured in the unit of the Ohm (Ω), but it is symbolized in equations by the capital letter "Z" rather than the capital letter "R". We use the term "impedance" to describe the headphone's opposition to current because it is primarily AC signals that headphones are normally subjected to, not DC.

Most small signal sources have high internal impedances, some much higher than the nominal 8Ω of the headphone speakers. This is a technical way of saying that they are incapable of supplying substantial amounts of current. As the Maximum Power Transfer Theorem predicts, maximum sound power will be delivered by the headphone speakers when their impedance is "matched" to the impedance of the voltage source. The transformer does this. The transformer also helps aid the detection of small DC signals by producing inductive "kickback" every time the test lead circuit is broken, thus "amplifying" the signal by magnetically storing up electrical energy and suddenly releasing it to the headphone speakers.

I recommend building this detector in a permanent fashion (mounting all components inside of a box, and providing nice test lead wires) so it may be easily used in the future. Constructed as such, it might look something like this:

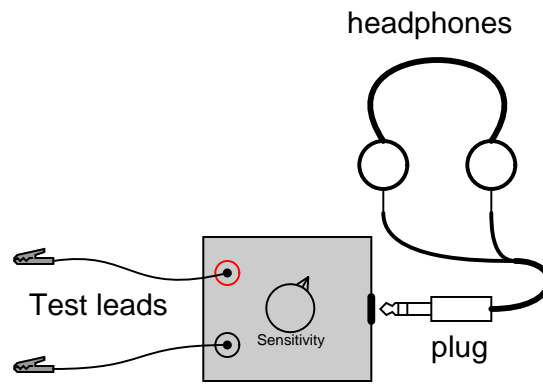

3.13 Potentiometric voltmeter

PARTS AND MATERIALS

- Two 6 volt batteries
- One potentiometer, single turn, 10 k Ω , linear taper (Radio Shack catalog # 271-1715)
- Two high-value resistors (at least 1 M Ω each)
- Sensitive voltage detector (from previous experiment)
- Analog voltmeter (from previous experiment)

The potentiometer value is not critical: anything from 1 k Ω to 100 k Ω is acceptable. If you have built the "precision potentiometer" described earlier in this chapter, it is recommended that you use it in this experiment.

Likewise, the actual values of the resistors are not critical. In this particular experiment, the greater the value, the better the results. They need not be precisely equal value, either.

If you have not yet built the sensitive voltage detector, it is recommended that you build one before proceeding with this experiment! It is a very useful, yet simple, piece of test equipment that you should not be without. You can use a digital multimeter set to the "DC millivolt" (DC mV) range in lieu of a voltage detector, but the headphone-based voltage detector is more appropriate because it demonstrates how you can make precise voltage measurements *without* using expensive or advanced meter equipment. I recommend using your home-made multimeter for the same reason, although any voltmeter will suffice for this experiment.

CROSS-REFERENCES

Lessons In Electric Circuits, Volume 1, chapter 8: "DC Metering Circuits"

LEARNING OBJECTIVES

- Voltmeter loading: its causes and its solution
- Using a potentiometer as a source of variable voltage
- Potentiometric method of voltage measurement

SCHEMATIC DIAGRAM

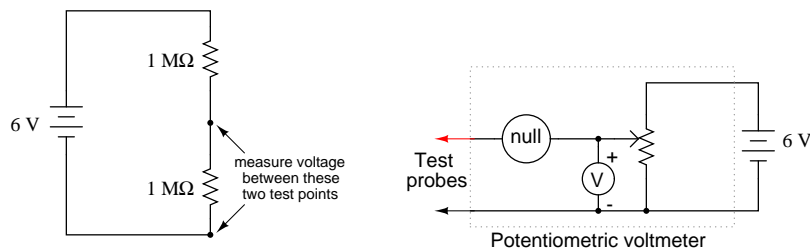

ILLUSTRATION

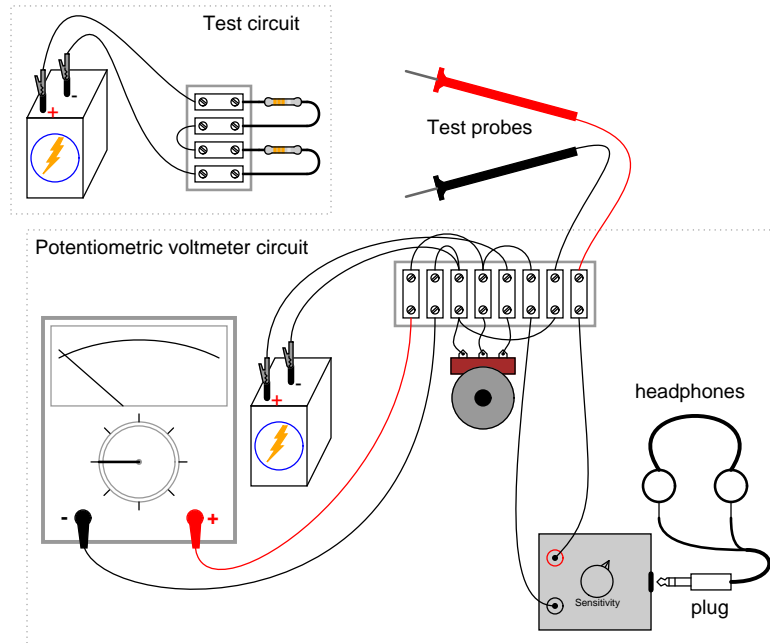

INSTRUCTIONS

Build the two-resistor voltage divider circuit shown on the left of the schematic diagram and of the illustration. If the two high-value resistors are of equal value, the battery's voltage should be split in half, with approximately 3 volts dropped across each resistor.

Measure the battery voltage directly with a voltmeter, then measure each resistor's voltage drop. Do you notice anything unusual about the voltmeter's readings? Normally, series voltage drops add to equal the total applied voltage, but in this case you will notice a serious discrepancy. Is Kirchhoff's Voltage Law untrue? Is this an exception to one of the most fundamental laws of electric circuits? No! What is happening is this: when you connect a voltmeter across either resistor, the voltmeter itself *alters* the circuit so that the voltage is not the same as with no meter connected.

I like to use the analogy of an air pressure gauge used to check the pressure of a pneumatic tire. When a gauge is connected to the tire's fill valve, it releases some air out of the tire. This affects the pressure in the tire, and so the gauge reads a slightly lower pressure than what was in the tire before the gauge was connected. In other words, the act of measuring tire pressure *alters* the tire's pressure. Hopefully, though, there is so little air released from the tire during the act of measurement that the reduction in pressure is negligible. Voltmeters similarly impact the voltage they measure, by bypassing some current around the component whose voltage drop is being measured. This affects the voltage drop, but the effect is so slight that you usually don't notice it.

In this circuit, though, the effect is very pronounced. Why is this? Try replacing the two high-value resistors with two of 100 k Ω value each and repeat the experiment. Replace those resistors with two 10 K Ω units and repeat. What do you notice about the voltage readings with

lower-value resistors? What does this tell you about voltmeter "impact" on a circuit in relation to that circuit's resistance? Replace any low-value resistors with the original, high-value ($\geq 1\text{ M}\Omega$) resistors before proceeding.

Try measuring voltage across the two high-value resistors – one at a time – with a digital voltmeter instead of an analog voltmeter. What do you notice about the digital meter's readings versus the analog meter's? Digital voltmeters typically have greater internal (probe-to-probe) resistance, meaning they draw less current than a comparable analog voltmeter when measuring the same voltage source. An ideal voltmeter would draw zero current from the circuit under test, and thus suffer no voltage "impact" problems.

If you happen to have two voltmeters, try this: connect one voltmeter across one resistor, and the other voltmeter across the other resistor. The voltage readings you get will add up to the total voltage this time, no matter what the resistor values are, even though they're different from the readings obtained from a single meter used twice. Unfortunately, though, it is unlikely that the voltage readings obtained this way are equal to the true voltage drops with no meters connected, and so it is not a practical solution to the problem.

Is there any way to make a "perfect" voltmeter: one that has infinite resistance and draws no current from the circuit under test? Modern laboratory voltmeters approach this goal by using semiconductor "amplifier" circuits, but this method is too technologically advanced for the student or hobbyist to duplicate. A much simpler and much older technique is called the *potentiometric* or *null-balance* method. This involves using an adjustable voltage source to "balance" the measured voltage. When the two voltages are equal, as indicated by a very sensitive *null detector*, the adjustable voltage source is measured with an ordinary voltmeter. Because the two voltage sources are equal to each other, measuring the adjustable source is the same as measuring across the test circuit, except that there is no "impact" error because the adjustable source provides any current needed by the voltmeter. Consequently, the circuit under test remains unaffected, allowing measurement of its true voltage drop.

Examine the following schematic to see how the potentiometric voltmeter method is implemented:

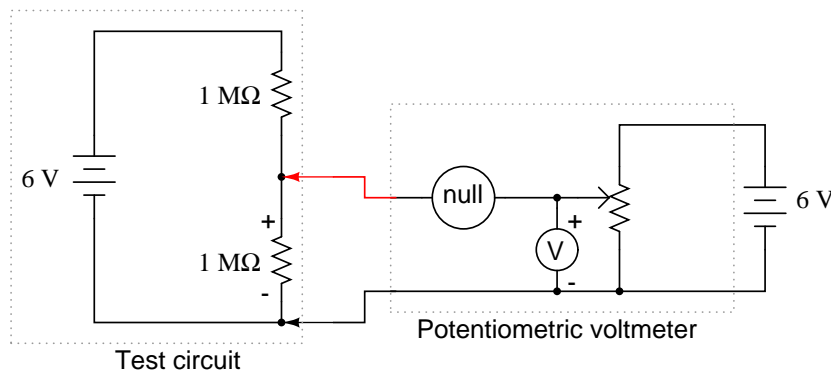

The circle symbol with the word "null" written inside represents the null detector. This can be any arbitrarily sensitive meter movement or voltage indicator. Its sole purpose in this circuit is to indicate when there is *zero* voltage: when the adjustable voltage source (potentiometer) is precisely equal to the voltage drop in the circuit under test. The more sensitive this null detector is, the more precisely the adjustable source may be adjusted to equal the voltage

under test, and the more precisely that test voltage may be measured.

Build this circuit as shown in the illustration and test its operation measuring the voltage drop across one of the high-value resistors in the test circuit. It may be easier to use a regular multimeter as a null detector at first, until you become familiar with the process of adjusting the potentiometer for a "null" indication, then reading the voltmeter connected across the potentiometer.

If you are using the headphone-based voltage detector as your null meter, you will need to intermittently make and break contact with the circuit under test and listen for "clicking" sounds. Do this by firmly securing one of the test probes to the test circuit and momentarily touching the other test probe to the other point in the test circuit again and again, listening for sounds in the headphones indicating a difference of voltage between the test circuit and the potentiometer. Adjust the potentiometer until no clicking sounds can be heard from the headphones. This indicates a "null" or "balanced" condition, and you may read the voltmeter indication to see how much voltage is dropped across the test circuit resistor. Unfortunately, the headphone-based null detector provides no indication of whether the potentiometer voltage is *greater than*, or *less than* the test circuit voltage, so you will have to listen for *decreasing* "click" intensity while turning the potentiometer to determine if you need to adjust the voltage higher or lower.

You may find that a single-turn ("3/4 turn") potentiometer is too coarse of an adjustment device to accurately "null" the measurement circuit. A multi-turn potentiometer may be used instead of the single-turn unit for greater adjustment precision, or the "precision potentiometer" circuit described in an earlier experiment may be used.

Prior to the advent of amplified voltmeter technology, the potentiometric method was the *only* method for making highly accurate voltage measurements. Even now, electrical standards laboratories make use of this technique along with the latest meter technology to minimize meter "impact" errors and maximize measurement accuracy. Although the potentiometric method requires more skill to use than simply connecting a modern digital voltmeter across a component, and is considered obsolete for all but the most precise measurement applications, it is still a valuable learning process for the new student of electronics, and a useful technique for the hobbyist who may lack expensive instrumentation in their home laboratory.

COMPUTER SIMULATION

Schematic with SPICE node numbers:

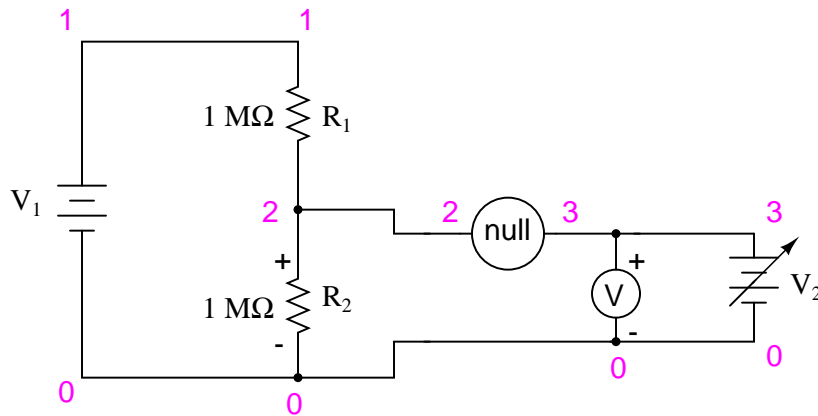

Netlist (make a text file containing the following text, verbatim):

```
Potentiometric voltmeter
v1 1 0 dc 6
v2 3 0
r1 1 2 1meg
r2 2 0 1meg
rnull 2 3 10k
rmeter 3 0 50k
.dc v2 0 6 0.5
.print dc v(2,0) v(2,3) v(3,0)
.end
```

This SPICE simulation shows the actual voltage across R_2 of the test circuit, the null detector's voltage, and the voltage across the adjustable voltage source, as that source is adjusted from 0 volts to 6 volts in 0.5 volt steps. In the output of this simulation, you will notice that the voltage across R_2 is impacted significantly when the measurement circuit is unbalanced, returning to its true voltage only when there is practically zero voltage across the null detector. At that point, of course, the adjustable voltage source is at a value of 3.000 volts: precisely equal to the (unaffected) test circuit voltage drop.

What is the lesson to be learned from this simulation? That a potentiometric voltmeter avoids impacting the test circuit *only* when it is in a condition of perfect balance ("null") with the test circuit!

3.14 4-wire resistance measurement

PARTS AND MATERIALS

- 6-volt battery
- Electromagnet made from experiment in previous chapter, or a large spool of wire

It would be ideal in this experiment to have two meters: one voltmeter and one ammeter. For experimenters on a budget, this may not be possible. Whatever ammeter is used should be capable measuring at least a few amps of current. A 6-volt "lantern" battery essentially short-circuited by a long piece of wire may produce currents of this magnitude, and your ammeter needs to be capable of measuring it without blowing a fuse or sustaining other damage. Make sure the highest current range on the meter is at least 5 amps!

CROSS-REFERENCES

Lessons In Electric Circuits, Volume 1, chapter 8: "DC Metering Circuits"

LEARNING OBJECTIVES

- Operating principle of Kelvin (4-wire) resistance measurement
- How to measure low resistances with common test equipment

SCHEMATIC DIAGRAM

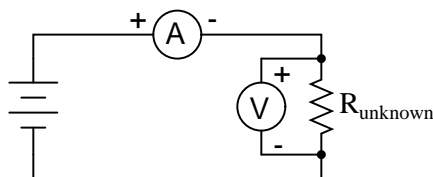

ILLUSTRATION

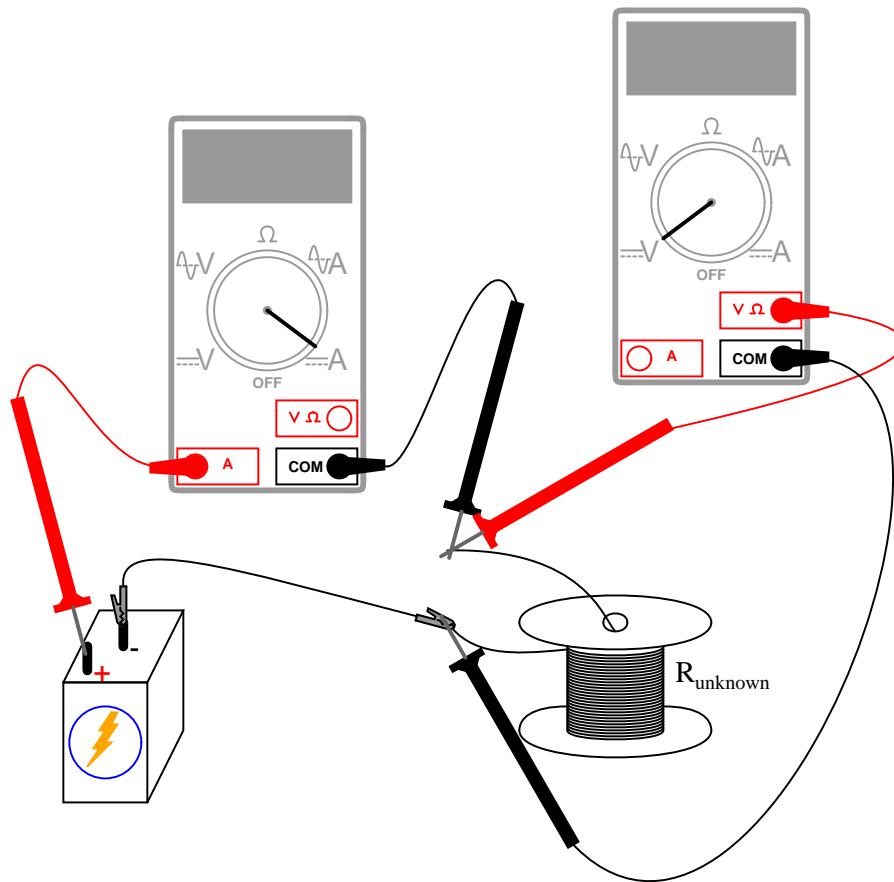

INSTRUCTIONS

Although this experiment is best performed with two meters, and indeed is shown as such in the schematic diagram and illustration, one multimeter is sufficient.

Most ohmmeters operate on the principle of applying a small voltage across an unknown resistance ($R_{unknown}$) and inferring resistance from the amount of current drawn by it. Except in special cases such as the *megger*, both the voltage and current quantities employed by the meter are quite small.

This presents a problem for measurement of low resistances, as a low resistance specimen may be of much smaller resistance value than the meter circuitry itself. Imagine trying to measure the diameter of a cotton thread with a yardstick, or measuring the weight of a coin with a scale built for weighing freight trucks, and you will appreciate the problem at hand.

One of the many sources of error in measuring small resistances with an ordinary ohmmeter is the resistance of the ohmmeter's own test leads. Being part of the measurement circuit, the test leads may contain more resistance than the resistance of the test specimen, incurring significant measurement error by their presence:

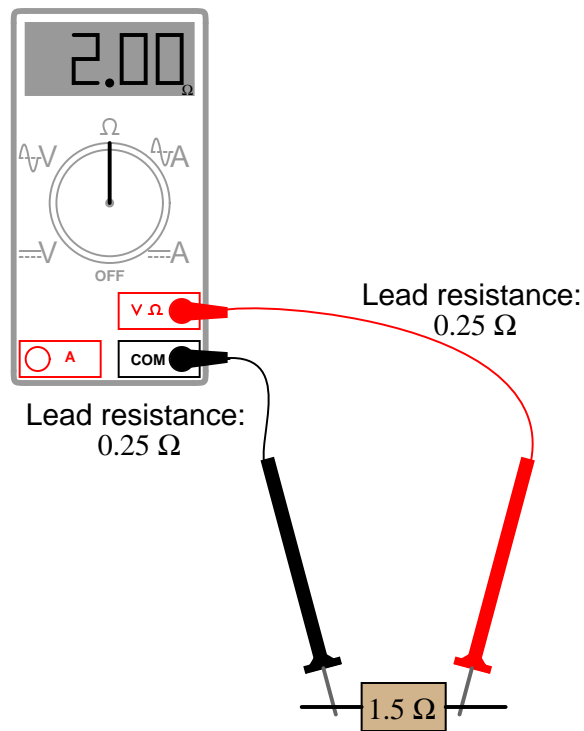

One solution is called the *Kelvin*, or *4-wire*, resistance measurement method. It involves the use of an ammeter and voltmeter, determining specimen resistance by Ohm's Law calculation. A current is passed through the unknown resistance and measured. The voltage dropped across the resistance is measured by the voltmeter, and resistance calculated using Ohm's Law ($R=E/I$). Very small resistances may be measured easily by using large current, providing a more easily measured voltage drop from which to infer resistance than if a small current were used.

Because only the voltage dropped by the unknown resistance is factored into the calculation – not the voltage dropped across the ammeter's test leads or any other connecting wires carrying the main current – errors otherwise caused by these stray resistances are completely eliminated.

First, select a suitably low resistance specimen to use in this experiment. I suggest the electromagnet coil specified in the last chapter, or a spool of wire where both ends may be accessed. Connect a 6-volt battery to this specimen, with an ammeter connected in series. **WARNING:** the ammeter used should be capable of measuring at least 5 amps of current, so that it will not be damaged by the (possibly) high current generated in this near-short circuit condition. If you have a second meter, use it to measure voltage across the specimen's connection points, as shown in the illustration, and record both meters' indications.

If you have only one meter, use it to measure current first, recording its indication as quickly as possible, then immediately opening (breaking) the circuit. Switch the meter to its voltage mode, connect it across the specimen's connection points, and re-connect the battery, quickly noting the voltage indication. You don't want to leave the battery connected to the specimen

for any longer than necessary for obtaining meter measurements, as it will begin to rapidly discharge due to the high circuit current, thus compromising measurement accuracy when the meter is re-configured and the circuit closed once more for the next measurement. When two meters are used, this is not as significant an issue, because the current and voltage indications may be recorded *simultaneously*.

Take the voltage measurement and divide it by the current measurement. The quotient will be equal to the specimen's resistance in ohms.

3.15 A very simple computer

PARTS AND MATERIALS

- Three batteries, each one with a different voltage
- Three equal-value resistors, between $10\text{ k}\Omega$ and $47\text{ k}\Omega$ each

When selecting resistors, measure each one with an ohmmeter and choose three that are the closest in value to each other. Precision is very important for this experiment!

CROSS-REFERENCES

Lessons In Electric Circuits, Volume 1, chapter 10: "DC Network Analysis"

LEARNING OBJECTIVES

- How a resistor network can function as a voltage signal averager
- Application of Millman's Theorem

SCHEMATIC DIAGRAM

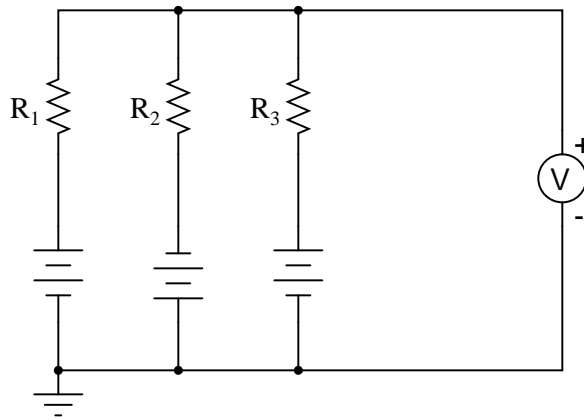

ILLUSTRATION

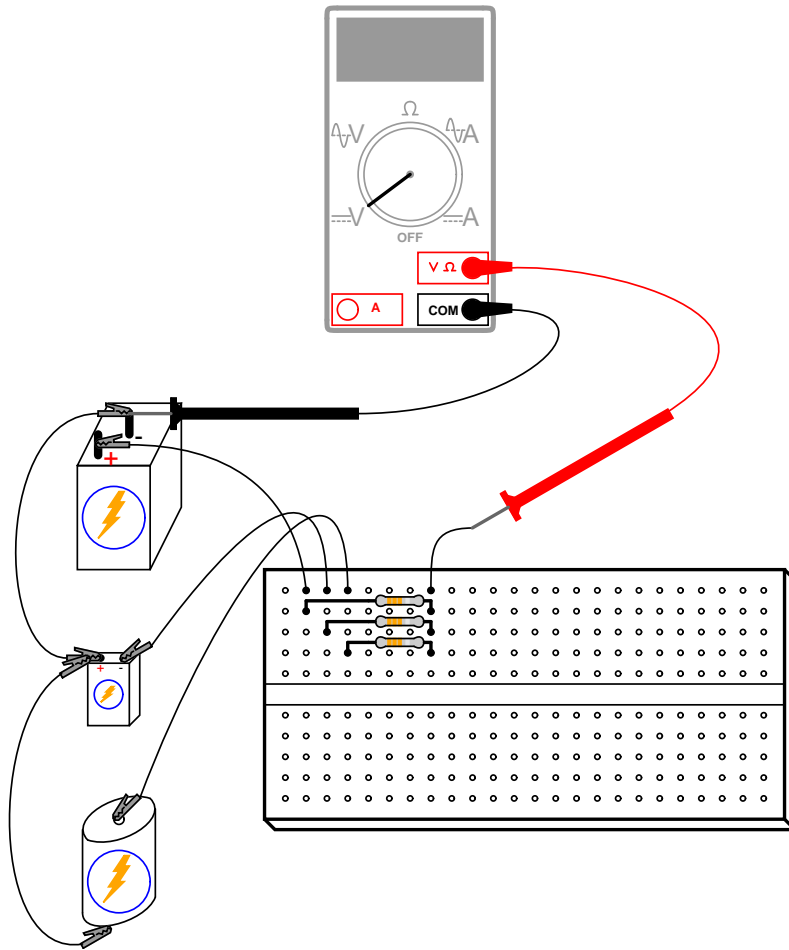

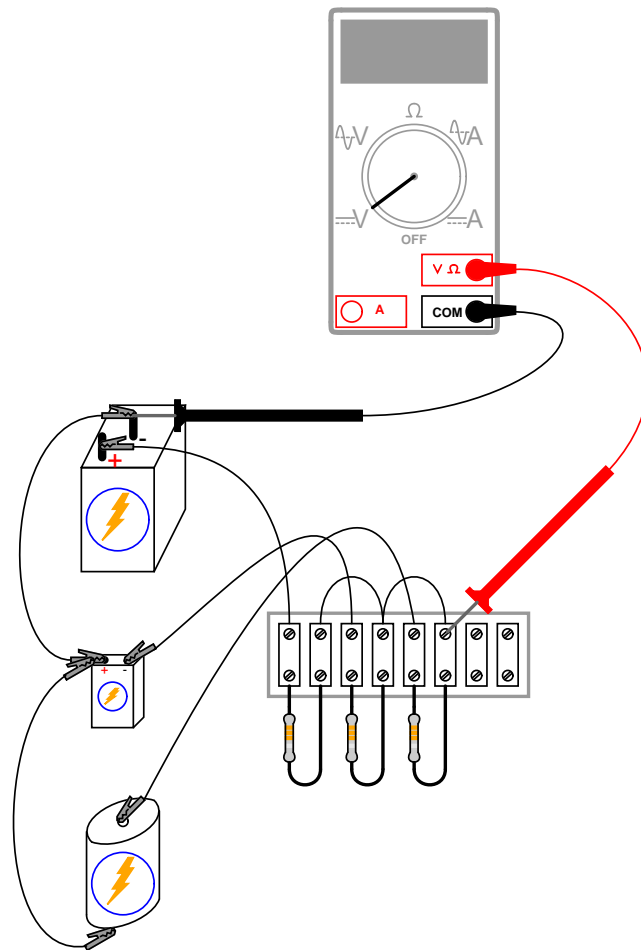

INSTRUCTIONS

This deceptively crude circuit performs the function of mathematically *averaging* three voltage signals together, and so fulfills a specialized computational role. In other words, it is a computer that can only do one mathematical operation: averaging three quantities together.

Build this circuit as shown and measure all battery voltages with a voltmeter. Write these voltage figures on paper and average them together ($E_1 + E_2 + E_3$, divided by three). When you measure each battery voltage, keep the black test probe connected to the "ground" point (the side of the battery directly joined to the other batteries by jumper wires), and touch the red probe to the other battery terminal. Polarity is important here! You will notice one battery in the schematic diagram connected "backward" to the other two, negative side "up." This battery's voltage should read as a negative quantity when measured by a properly connected digital meter, the other batteries measuring positive.

When the voltmeter is connected to the circuit at the point shown in the schematic and illustrations, it should register the algebraic average of the three batteries' voltages. If the

resistor values are chosen to match each other very closely, the "output" voltage of this circuit should match the calculated average very closely as well.

If one battery is disconnected, the output voltage will equal the average voltage of the remaining batteries. If the jumper wires formerly connecting the removed battery to the averager circuit are connected to each other, the circuit will average the two remaining voltages together with 0 volts, producing a smaller output signal:

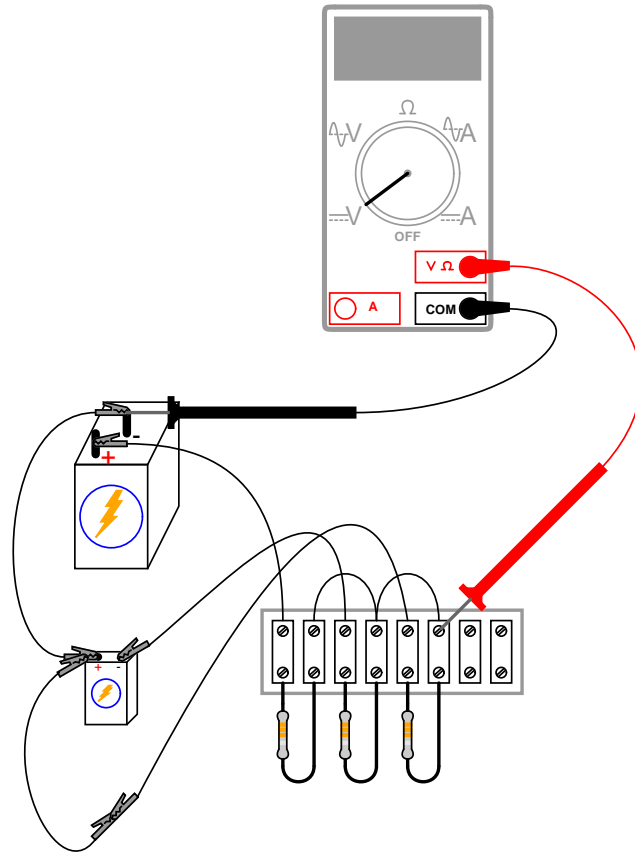

The sheer simplicity of this circuit deters most people from calling it a "computer," but it undeniably performs the mathematical function of averaging. Not only does it perform this function, but it performs it much faster than any modern digital computer can! Digital computers, such as personal computers (PCs) and pushbutton calculators, perform mathematical operations in a series of discrete steps. Analog computers perform calculations in continuous fashion, exploiting Ohm's and Kirchhoff's Laws for an arithmetic purpose, the "answer" computed as fast as voltage propagates through the circuit (ideally, at the speed of light!).

With the addition of circuits called *amplifiers*, voltage signals in analog computer networks may be boosted and re-used in other networks to perform a wide variety of mathematical functions. Such analog computers excel at performing the calculus operations of numerical differentiation and integration, and as such may be used to simulate the behavior of complex mechanical, electrical, and even chemical systems. At one time, analog computers were the

ultimate tool for engineering research, but since then have been largely supplanted by digital computer technology. Digital computers enjoy the advantage of performing mathematical operations with much better precision than analog computers, albeit at much slower theoretical speeds.

COMPUTER SIMULATION

Schematic with SPICE node numbers:

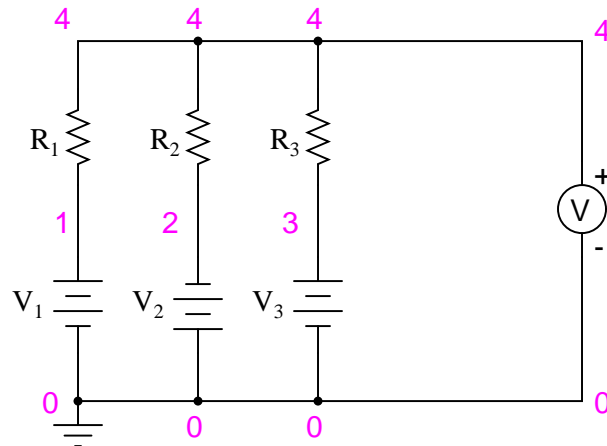

Netlist (make a text file containing the following text, verbatim):

```
Voltage averager
v1 1 0
v2 0 2 dc 9
v3 3 0 dc 1.5
r1 1 4 10k
r2 2 4 10k
r3 3 4 10k
.dc v1 6 6 1
.print dc v(4,0)
.end
```

With this SPICE netlist, we can force a digital computer to simulate and analog computer, which averages three numbers together. Obviously, we aren't doing this for the practical task of averaging numbers, but rather to learn more about circuits and more about computer simulation of circuits!

3.16 Potato battery

PARTS AND MATERIALS

- One large potato
- One lemon (optional)
- Strip of zinc, or galvanized metal
- Piece of thick copper wire

The basic experiment is based on the use of a potato, but many fruits and vegetables work as potential batteries!

For the zinc electrode, a large galvanized nail works well. Nails with a thick, rough zinc texture are preferable to galvanized nails that are smooth.

CROSS-REFERENCES

Lessons In Electric Circuits, Volume 1, chapter 11: "Batteries and Power Systems"

LEARNING OBJECTIVES

- The importance of chemical activity in battery operation
- How electrode surface area affects battery operation

ILLUSTRATION

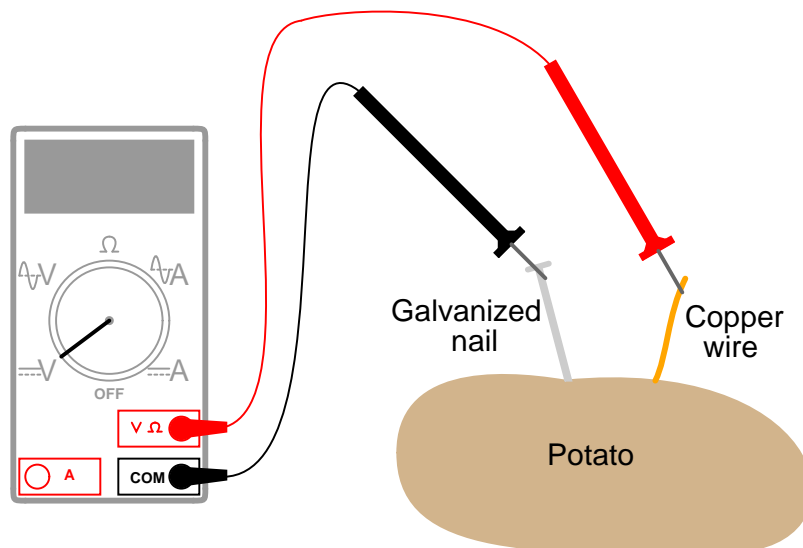

INSTRUCTIONS

Push both the nail and the wire deep into the potato. Measure voltage output by the potato battery with a voltmeter. Now, wasn't that easy?

Seriously, though, experiment with different metals, electrode depths, and electrode spacings to obtain the greatest voltage possible from the potato. Try other vegetables or fruits and compare voltage output with the same electrode metals.

It can be difficult to power a load with a single "potato" battery, so don't expect to light up an incandescent lamp or power a hobby motor or do anything like that. Even if the voltage output is adequate, a potato battery has a fairly high internal resistance which causes its voltage to "sag" badly under even a light load. With multiple potato batteries connected in series, parallel, or series-parallel arrangement, though, it is possible to obtain enough voltage and current capacity to power a small load.

3.17 Capacitor charging and discharging

PARTS AND MATERIALS

- 6 volt battery
- Two large electrolytic capacitors, 1000 μF minimum (Radio Shack catalog # 272-1019, 272-1032, or equivalent)
- Two 1 k Ω resistors
- One toggle switch, SPST ("Single-Pole, Single-Throw")

Large-value capacitors are required for this experiment to produce time constants slow enough to track with a voltmeter and stopwatch. Be warned that most large capacitors are of the "electrolytic" type, and they are *polarity sensitive*! One terminal of each capacitor should be marked with a definite polarity sign. Usually capacitors of the size specified have a negative (-) marking or series of negative markings pointing toward the negative terminal. Very large capacitors are often polarity-labeled by a positive (+) marking next to one terminal. Failure to heed proper polarity will almost surely result in capacitor failure, even with a source voltage as low as 6 volts. When electrolytic capacitors fail, they typically **explode**, spewing caustic chemicals and emitting foul odors. Please, try to avoid this!

I recommend a household light switch for the "SPST toggle switch" specified in the parts list.

CROSS-REFERENCES

Lessons In Electric Circuits, Volume 1, chapter 13: "Capacitors"

Lessons In Electric Circuits, Volume 1, chapter 16: "RC and L/R Time Constants"

LEARNING OBJECTIVES

- Capacitor charging action
- Capacitor discharging action
- Time constant calculation
- Series and parallel capacitance

SCHEMATIC DIAGRAM

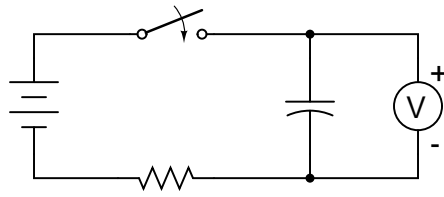

Charging circuit

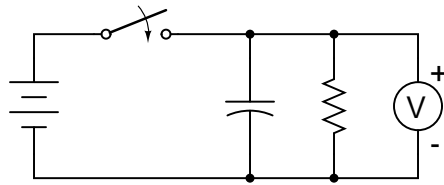

Discharging circuit

ILLUSTRATION

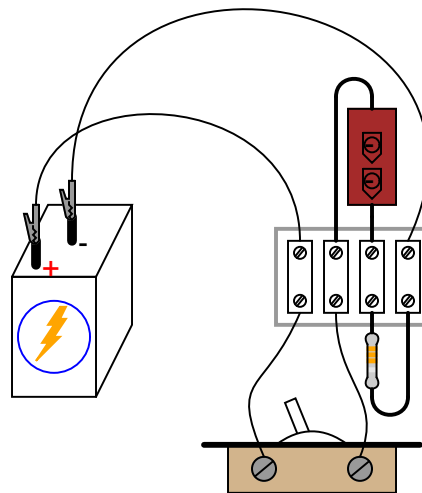

Charging circuit

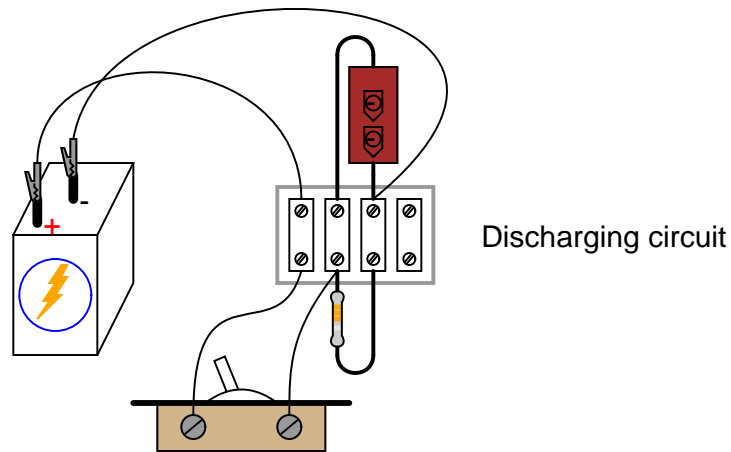

INSTRUCTIONS

Build the "charging" circuit and measure voltage across the capacitor when the switch is closed. Notice how it increases slowly over time, rather than suddenly as would be the case with a resistor. You can "reset" the capacitor back to a voltage of zero by shorting across its terminals with a piece of wire.

The "time constant" (τ) of a resistor capacitor circuit is calculated by taking the circuit resistance and multiplying it by the circuit capacitance. For a $1\text{ k}\Omega$ resistor and a $1000\ \mu\text{F}$ capacitor, the time constant should be 1 second. This is the amount of time it takes for the capacitor voltage to increase approximately 63.2% from its present value to its final value: the voltage of the battery.

It is educational to plot the voltage of a charging capacitor over time on a sheet of graph paper, to see how the inverse exponential curve develops. In order to plot the action of this circuit, though, we must find a way of slowing it down. A one-second time constant doesn't provide much time to take voltmeter readings!

We can increase this circuit's time constant two different ways: changing the total circuit resistance, and/or changing the total circuit capacitance. Given a pair of identical resistors and a pair of identical capacitors, experiment with various series and parallel combinations to obtain the slowest charging action. You should already know by now how multiple resistors need to be connected to form a greater total resistance, but what about capacitors? This circuit will demonstrate to you how capacitance changes with series and parallel capacitor connections. Just be sure that you insert the capacitor(s) in the proper direction: with the ends labeled negative (-) electrically "closest" to the battery's negative terminal!

The discharging circuit provides the same kind of changing capacitor voltage, except this time the voltage jumps to full battery voltage when the switch closes and slowly falls when the switch is opened. Experiment once again with different combinations of resistors and capacitors, making sure as always that the capacitor's polarity is correct.

COMPUTER SIMULATION

Schematic with SPICE node numbers:

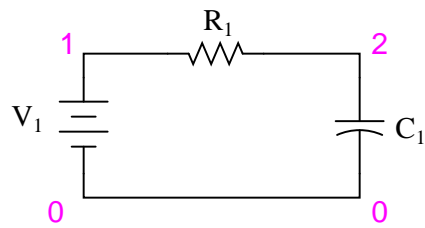

Netlist (make a text file containing the following text, verbatim):

```
Capacitor charging circuit
v1 1 0 dc 6
r1 1 2 1k
c1 2 0 1000u ic=0
.tran 0.1 5 uic
.plot tran v(2,0)
.end
```

3.18 Rate-of-change indicator

PARTS AND MATERIALS

- Two 6 volt batteries
- Capacitor, $0.1 \mu\text{F}$ (Radio Shack catalog # 272-135)
- $1 \text{ M}\Omega$ resistor
- Potentiometer, single turn, $5 \text{ k}\Omega$, linear taper (Radio Shack catalog # 271-1714)

The potentiometer value is not especially critical, although lower-resistance units will, in theory, work better for this experiment than high-resistance units. I've used a $10 \text{ k}\Omega$ potentiometer for this circuit with excellent results.

CROSS-REFERENCES

Lessons In Electric Circuits, Volume 1, chapter 13: "Capacitors"

LEARNING OBJECTIVES

- How to build a differentiator circuit
- Obtain an empirical understanding of the *derivative* calculus function

SCHEMATIC DIAGRAM

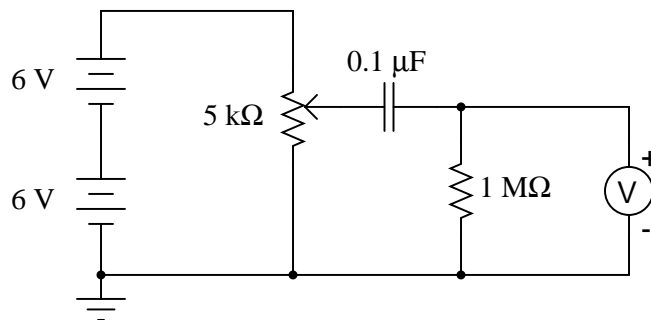

ILLUSTRATION

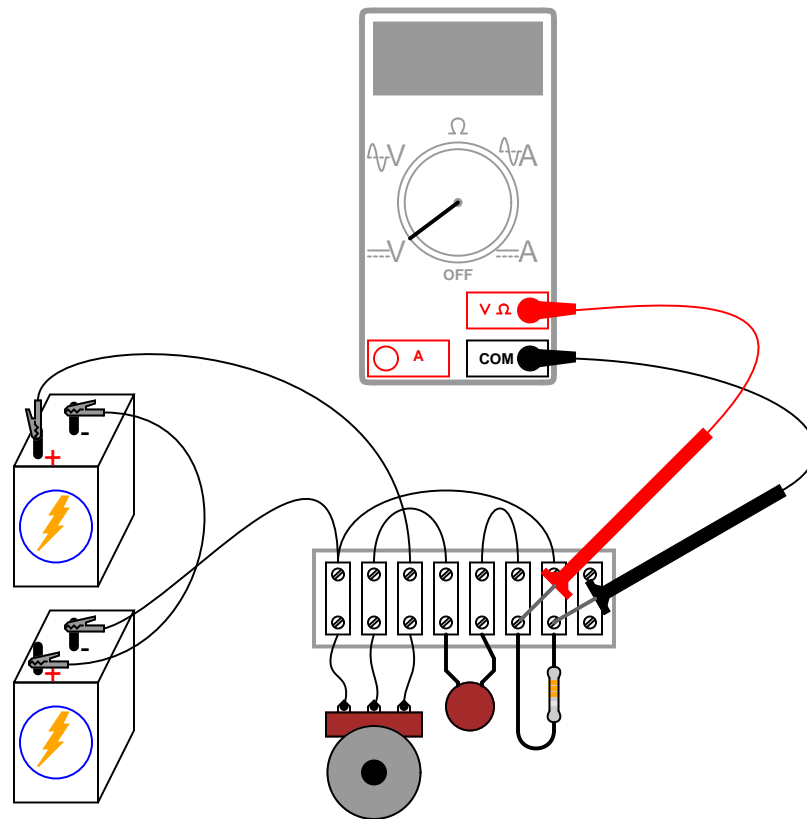

INSTRUCTIONS

Measure voltage between the potentiometer's wiper terminal and the "ground" point shown in the schematic diagram (the negative terminal of the lower 6-volt battery). This is the input voltage for the circuit, and you can see how it smoothly varies between zero and 12 volts as the potentiometer control is turned full-range. Since the potentiometer is used here as a voltage divider, this behavior should be unsurprising to you.

Now, measure voltage across the $1\text{ M}\Omega$ resistor while moving the potentiometer control. A digital voltmeter is highly recommended, and I advise setting it to a very sensitive (millivolt) range to obtain the strongest indications. What does the voltmeter indicate while the potentiometer is *not* being moved? Turn the potentiometer slowly clockwise and note the voltmeter's indication. Turn the potentiometer slowly counter-clockwise and note the voltmeter's indication. What difference do you see between the two different directions of potentiometer control motion?

Try moving the potentiometer in such a way that the voltmeter gives a steady, small indication. What kind of potentiometer motion provides the *stadiest* voltage across the $1\text{ M}\Omega$ resistor?

In calculus, a function representing the rate of change of one variable as compared to another is called the *derivative*. This simple circuit illustrates the concept of the derivative by producing an output voltage proportional to the input voltage's *rate of change over time*. Be-

cause this circuit performs the calculus function of differentiation with respect to time (outputting the time-derivative of an incoming signal), it is called a *differentiator* circuit.

Like the *averager* circuit shown earlier in this chapter, the differentiator circuit is a kind of analog computer. Differentiation is a far more complex mathematical function than averaging, especially when implemented in a digital computer, so this circuit is an excellent demonstration of the elegance of analog circuitry in performing mathematical computations.

More accurate differentiator circuits may be built by combining resistor-capacitor networks with electronic *amplifier* circuits. For more detail on computational circuitry, go to the "Analog Integrated Circuits" chapter in this Experiments volume.

Chapter 4

AC CIRCUITS

Contents

4.1 Introduction	145
4.2 Transformer – power supply	147
4.3 Build a transformer	151
4.4 Variable inductor	153
4.5 Sensitive audio detector	155
4.6 Sensing AC magnetic fields	160
4.7 Sensing AC electric fields	162
4.8 Automotive alternator	164
4.9 Induction motor	170
4.10 Phase shift	174
4.11 Sound cancellation	177
4.12 Musical keyboard as a signal generator	180
4.13 PC Oscilloscope	183
4.14 Waveform analysis	186
4.15 Inductor-capacitor "tank" circuit	188
4.16 Signal coupling	191

4.1 Introduction

"AC" stands for **Alternating Current**, which can refer to either voltage or current that alternates in polarity or direction, respectively. These experiments are designed to introduce you to several important concepts specific to AC.

A convenient source of AC voltage is household wall-socket power, which presents significant shock hazard. In order to minimize this hazard while taking advantage of the convenience of this source of AC, a small *power supply* will be the first project, consisting of a *transformer*

that steps the hazardous voltage (110 to 120 volts AC, RMS) down to 12 volts or less. The title of "power supply" is somewhat misleading. This device does not really act as a source or *supply* of power, but rather as a power *converter*, to reduce the hazardous voltage of wall-socket power to a much safer level.

4.2 Transformer – power supply

PARTS AND MATERIALS

- Power transformer, 120VAC step-down to 12VAC, with center-tapped secondary winding (Radio Shack catalog # 273-1365, 273-1352, or 273-1511).
- Terminal strip with at least three terminals.
- Household wall-socket power plug and cord.
- Line cord switch.
- Box (optional).
- Fuse and fuse holder (optional).

Power transformers may be obtained from old radios, which can usually be obtained from a thrift store for a few dollars (or less!). The radio would also provide the power cord and plug necessary for this project. Line cord switches may be obtained from a hardware store. If you want to be absolutely sure what kind of transformer you're getting, though, you should purchase one from an electronics supply store.

If you decide to equip your power supply with a fuse, be sure to get a *slow-acting*, or *slow-blow* fuse. Transformers may draw high "surge" currents when initially connected to an AC source, and these transient currents will blow a fast-acting fuse. Determine the proper current rating of the fuse by dividing the transformer's "VA" rating by 120 volts: in other words, calculate the full allowable primary winding current and size the fuse accordingly.

CROSS-REFERENCES

Lessons In Electric Circuits, Volume 2, chapter 1: "Basic AC Theory"

Lessons In Electric Circuits, Volume 2, chapter 9: "Transformers"

LEARNING OBJECTIVES

- Transformer voltage step-down behavior.
- Purpose of tapped windings.
- Safe wiring techniques for power cords.

SCHEMATIC DIAGRAM

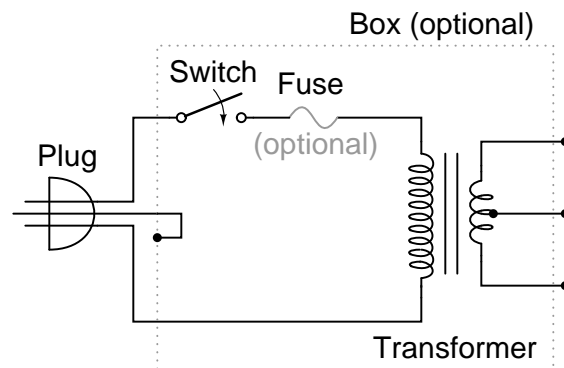

ILLUSTRATION

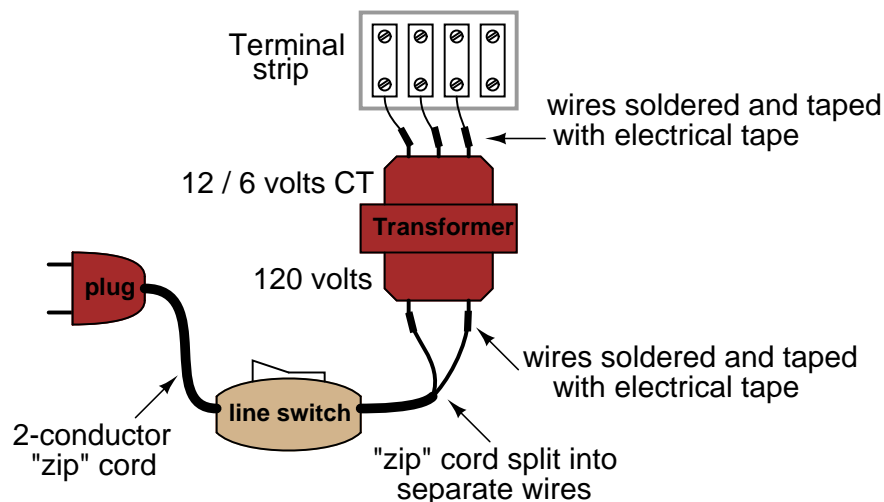

INSTRUCTIONS

Warning! *This project involves the use of dangerous voltages.* You must make sure all high-voltage (120 volt household power) conductors are safely insulated from accidental contact. No bare wires should be seen anywhere on the "primary" side of the transformer circuit. Be sure to *solder* all wire connections so that they're secure, and use real electrical tape (not duct tape, scotch tape, packing tape, or any other kind!) to insulate your soldered connections.

If you wish to enclose the transformer inside of a box, you may use an electrical "junction" box, obtained from a hardware store or electrical supply house. If the enclosure used is metal rather than plastic, a three-prong plug should be used, with the "ground" prong (the longest one on the plug) connected directly to the metal case for maximum safety.

Before plugging the plug into a wall socket, do a *safety check* with an ohmmeter. With the line switch in the "on" position, measure resistance between either plug prong and the transformer case. There should be infinite (maximum) resistance. If the meter registers continuity (some resistance value less than infinity), then you have a "short" between one of the power conductors and the case, which is dangerous!

Next, check the transformer windings themselves for continuity. With the line switch in the "on" position, there should be a small amount of resistance between the two plug prongs. When the switch is turned "off," the resistance indication should increase to infinity (open circuit – no continuity). Measure resistance between pairs of wires on the secondary side. These secondary windings should register much lower resistances than the primary. Why is this?

Plug the cord into a wall socket and turn the switch on. You should be able to measure AC voltage at the secondary side of the transformer, between pairs of terminals. Between two of these terminals, you should measure about 12 volts. Between either of these two terminals and the third terminal, you should measure half that. This third wire is the "center-tap" wire of the secondary winding.

It would be advisable to keep this project assembled for use in powering other experiments shown in this book. From here on, I will designate this "low-voltage AC power supply" using this illustration:

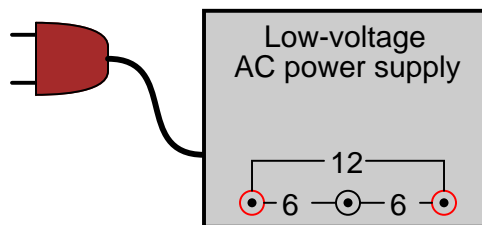

COMPUTER SIMULATION

Schematic with SPICE node numbers:

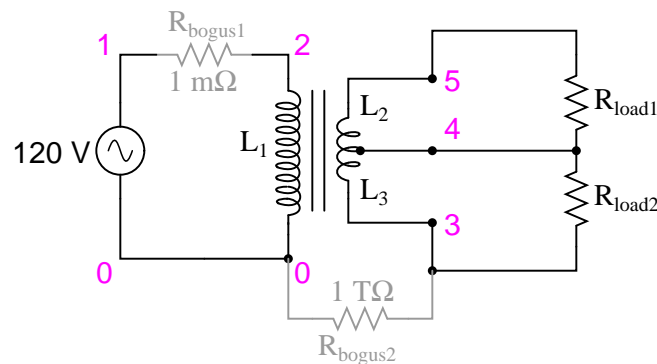

Netlist (make a text file containing the following text, verbatim):

```
transformer with center-tap secondary
v1 1 0 ac 120 sin
rbogus1 1 2 1e-3
l1 2 0 10
l2 5 4 0.025
l3 4 3 0.025
k1 l1 l2 0.999
k2 l2 l3 0.999
```

```
k3 11 13 0.999
rbogus2 3 0 1e12
rload1 5 4 1k
rload2 4 3 1k
* Sets up AC analysis at 60 Hz:
.ac lin 1 60 60
* Prints primary voltage between nodes 2 and 0:
.print ac v(2,0)
* Prints (top) secondary voltage between nodes 5 and 4:
.print ac v(5,4)
* Prints (bottom) secondary voltage between nodes 4 and 3:
.print ac v(4,3)
* Prints (total) secondary voltage between nodes 5 and 3:
.print ac v(5,3)
.end
```

4.3 Build a transformer

PARTS AND MATERIALS

- Steel flatbar, 4 pieces
- Miscellaneous bolts, nuts, washers
- 28 gauge "magnet" wire
- Low-voltage AC power supply

"Magnet wire" is small-gauge wire insulated with a thin enamel coating. It is intended to be used to make electromagnets, because many "turns" of wire may be wrapped in a relatively small-diameter coil. Any gauge of wire will work, but 28 gauge is recommended so as to make a coil with as many turns as possible in a small diameter.

CROSS-REFERENCES

Lessons In Electric Circuits, Volume 2, chapter 9: "Transformers"

LEARNING OBJECTIVES

- Effects of electromagnetism.
- Effects of electromagnetic induction.
- Effects of magnetic coupling on voltage regulation.
- Effects of winding turns on "step" ratio.

SCHEMATIC DIAGRAM

Transformer



ILLUSTRATION

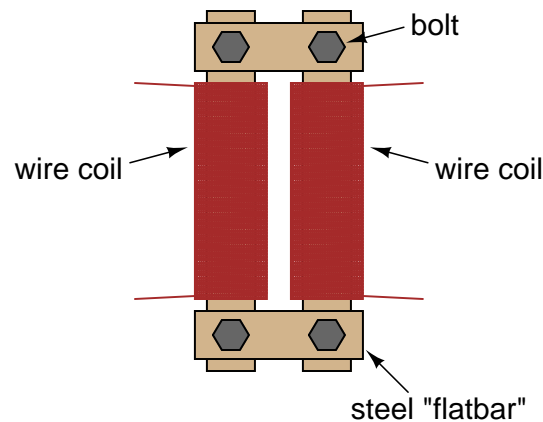

INSTRUCTIONS

Wrap two, equal-length bars of steel with a thin layer of electrically-insulating tape. Wrap several hundred turns of magnet wire around these two bars. You may make these windings with an equal or unequal number of turns, depending on whether or not you want the transformer to be able to "step" voltage up or down. I recommend equal turns to begin with, then experiment later with coils of unequal turn count.

Join those bars together in a rectangle with two other, shorter, bars of steel. Use bolts to secure the bars together (it is recommended that you drill bolt holes through the bars *before* you wrap wire around them).

Check for shorted windings (ohmmeter reading between wire ends and steel bar) after you're finished wrapping the windings. There should be no continuity (infinite resistance) between the winding and the steel bar. Check for continuity between winding ends to ensure that the wire isn't broken open somewhere within the coil. If either resistance measurements indicate a problem, the winding must be re-made.

Power your transformer with the low-voltage output of the "power supply" described at the beginning of this chapter. **Do not** power your transformer directly from wall-socket voltage (120 volts), as your home-made windings really aren't rated for any significant voltage!

Measure the output voltage (secondary winding) of your transformer with an AC voltmeter. Connect a load of some kind (light bulbs are good!) to the secondary winding and re-measure voltage. Note the degree of voltage "sag" at the secondary winding as load current is increased.

Loosen or remove the connecting bolts from one of the short bar pieces, thus increasing the *reluctance* (analogous to *resistance*) of the magnetic "circuit" coupling the two windings together. Note the effect on output voltage and voltage "sag" under load.

If you've made your transformer with unequal-turn windings. try it in step-up versus step-down mode, powering different AC loads.

4.4 Variable inductor

PARTS AND MATERIALS

- Paper tube, from a toilet-paper roll
- Bar of iron or steel, large enough to almost fill diameter of paper tube
- 28 gauge "magnet" wire
- Low-voltage AC power supply
- Incandescent lamp, rated for power supply voltage

CROSS-REFERENCES

Lessons In Electric Circuits, Volume 1, chapter 14: "Magnetism and Electromagnetism"

Lessons In Electric Circuits, Volume 1, chapter 15: "Inductors"

Lessons In Electric Circuits, Volume 2, chapter 3: "Reactance and Impedance – Inductive"

LEARNING OBJECTIVES

- Effects of magnetic permeability on inductance.
- How inductive reactance can control current in an AC circuit.

SCHEMATIC DIAGRAM

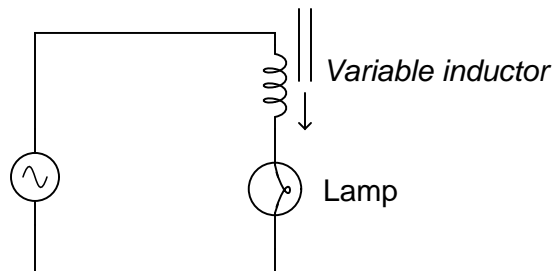

ILLUSTRATION

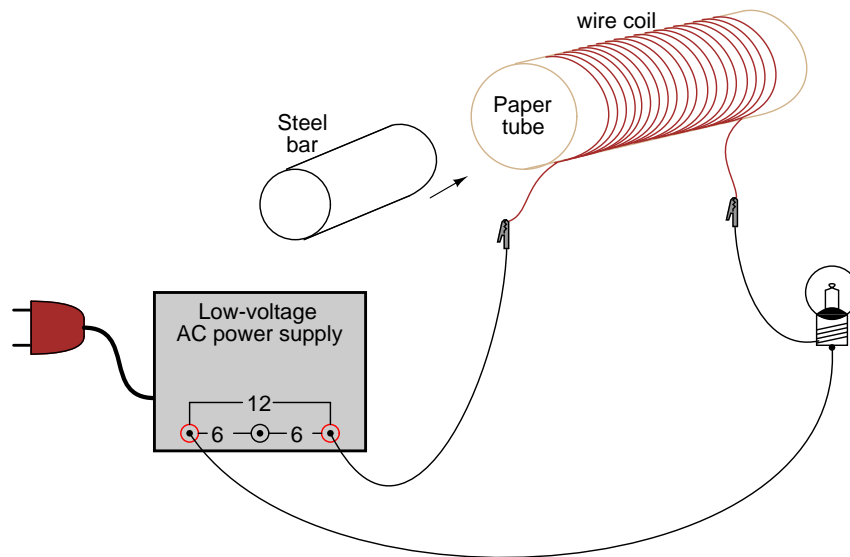

INSTRUCTIONS

Wrap hundreds of turns of magnet wire around the paper tube. Connect this home-made inductor in series with an AC power supply and lamp to form a circuit. When the tube is empty, the lamp should glow brightly. When the steel bar is inserted in the tube, the lamp dims from increased inductance (L) and consequently increased inductive reactance (X_L).

Try using bars of different materials, such as copper and stainless steel, if available. Not all metals have the same effect, due to differences in magnetic *permeability*.

4.5 Sensitive audio detector

PARTS AND MATERIALS

- High-quality "closed-cup" audio headphones
- Headphone jack: female receptacle for headphone plug (Radio Shack catalog # 274-312)
- Small step-down power transformer (Radio Shack catalog # 273-1365 or equivalent, using the 6-volt secondary winding tap)
- Two 1N4001 rectifying diodes (Radio Shack catalog # 276-1101)
- 1 k Ω resistor
- 100 k Ω potentiometer (Radio Shack catalog # 271-092)
- Two "banana" jack style binding posts, or other terminal hardware, for connection to potentiometer circuit (Radio Shack catalog # 274-662 or equivalent)
- Plastic or metal mounting box

Regarding the headphones, the higher the "sensitivity" rating in decibels (dB), the better, but listening is believing: if you're serious about building a detector with maximum sensitivity for small electrical signals, you should try a few different headphone models at a high-quality audio store and "listen" for which ones produce an audible sound for the *lowest* volume setting on a radio or CD player. Beware, as you could spend hundreds of dollars on a pair of headphones to get the absolute best sensitivity! Take heart, though: I've used an *old* pair of Radio Shack "Realistic" brand headphones with perfectly adequate results, so you don't need to buy the best.

Normally, the transformer used in this type of application (audio speaker impedance matching) is called an "audio transformer," with its primary and secondary windings represented by impedance values (1000 Ω : 8 Ω) instead of voltages. An audio transformer will work, but I've found small step-down power transformers of 120/6 volt ratio to be perfectly adequate for the task, cheaper (especially when taken from an old thrift-store alarm clock radio), and far more rugged.

The tolerance (precision) rating for the 1 k Ω resistor is irrelevant. The 100 k Ω potentiometer is a recommended option for incorporation into this project, as it gives the user control over the loudness for any given signal. Even though an *audio-taper* potentiometer would be appropriate for this application, it is not necessary. A *linear-taper* potentiometer works quite well.

CROSS-REFERENCES

Lessons In Electric Circuits, Volume 1, chapter 8: "DC Metering Circuits"

Lessons In Electric Circuits, Volume 2, chapter 9: "Transformers"

Lessons In Electric Circuits, Volume 2, chapter 12: "AC Metering Circuits"

LEARNING OBJECTIVES

- Soldering practice
- Use of a transformer for impedance matching
- Detection of extremely small electrical signals
- Using diodes to "clip" voltage at some maximum level

SCHEMATIC DIAGRAM

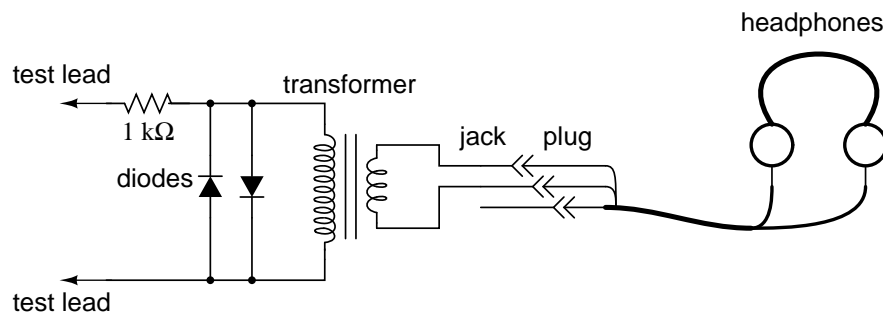

ILLUSTRATION

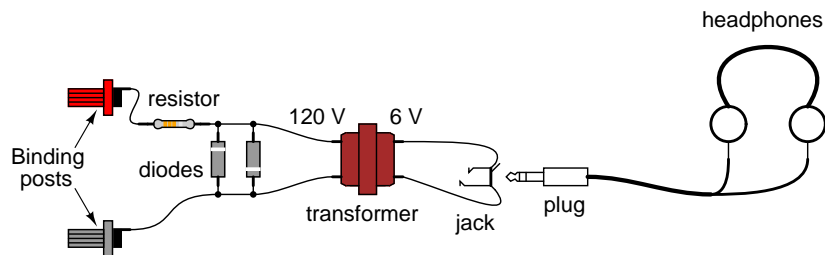

INSTRUCTIONS

This experiment is identical in construction to the "Sensitive Voltage Detector" described in the DC experiments chapter. If you've already built this detector, you may skip this experiment.

The headphones, most likely being stereo units (separate left and right speakers) will have a three-contact plug. You will be connecting to only two of those three contact points. If you only have a "mono" headphone set with a two-contact plug, just connect to those two contact points. You may either connect the two stereo speakers in series or in parallel. I've found the series connection to work best, that is, to produce the most sound from a small signal:

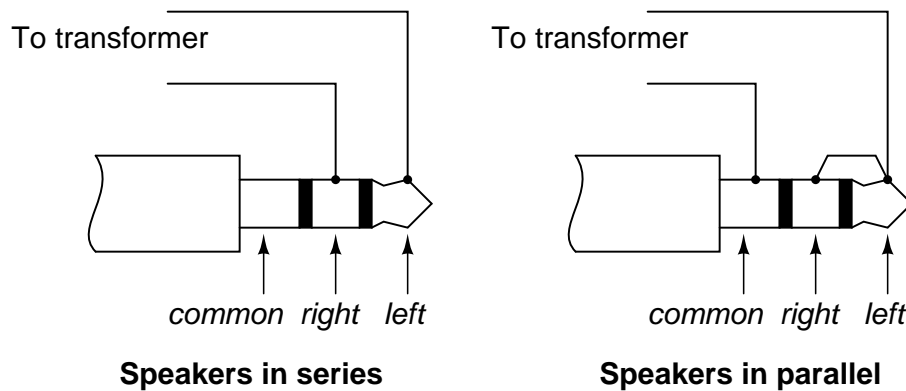

Solder all wire connections well. This detector system is extremely sensitive, and any loose wire connections in the circuit will add unwanted noise to the sounds produced by the measured voltage signal. The two diodes connected in parallel with the transformer's primary winding, along with the series-connected $1\text{ k}\Omega$ resistor, work together to "clip" the input voltage to a maximum of about 0.7 volts. This does one thing and one thing only: limit the amount of sound the headphones can produce. The system will work without the diodes and resistor in place, but there will be no limit to sound volume in the circuit, and the resulting sound caused by accidentally connecting the test leads across a substantial voltage source (like a battery) can be deafening!

Binding posts provide points of connection for a pair of test probes with banana-style plugs, once the detector components are mounted inside a box. You may use ordinary multimeter probes, or make your own probes with alligator clips at the ends for secure connection to a circuit.

Detectors are intended to be used for balancing bridge measurement circuits, potentiometric (null-balance) voltmeter circuits, and detect extremely low-amplitude AC ("alternating current") signals in the audio frequency range. It is a valuable piece of test equipment, especially for the low-budget experimenter without an oscilloscope. It is also valuable in that it allows you to use a different bodily sense in interpreting the behavior of a circuit.

For connection across any non-trivial source of voltage (1 volt and greater), the detector's extremely high sensitivity should be attenuated. This may be accomplished by connecting a voltage divider to the "front" of the circuit:

SCHEMATIC DIAGRAM

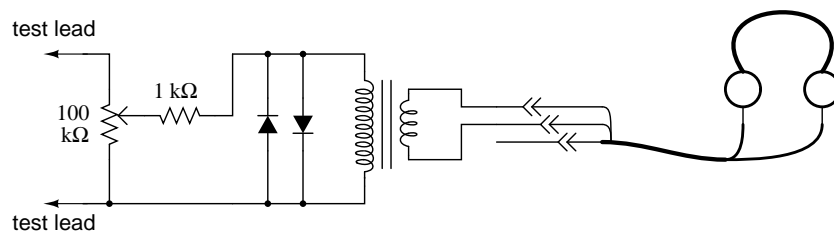

ILLUSTRATION

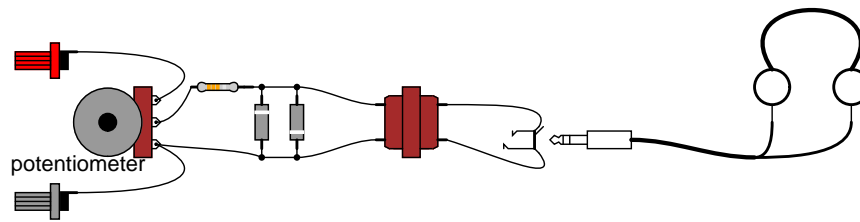

Adjust the 100 k Ω voltage divider potentiometer to about mid-range when initially sensing a voltage signal of unknown magnitude. If the sound is too loud, turn the potentiometer down and try again. If too soft, turn it up and try again. This detector even senses DC and radio-frequency signals (frequencies below and above the audio range, respectively), a “click” being heard whenever the test leads make or break contact with the source under test. With my cheap headphones, I’ve been able to detect currents of less than 1/10 of a microamp ($< 0.1 \mu\text{A}$) DC, and similarly low-magnitude RF signals up to 2 MHz.

A good demonstration of the detector’s sensitivity is to touch both test leads to the end of your tongue, with the sensitivity adjustment set to maximum. The voltage produced by metal-to-electrolyte contact (called *galvanic voltage*) is very small, but enough to produce soft “clicking” sounds every time the leads make and break contact on the wet skin of your tongue.

Try unplugging the headphone plug from the jack (receptacle) and similarly touching it to the end of your tongue. You should still hear soft clicking sounds, but they will be much smaller in amplitude. Headphone speakers are “low impedance” devices: they require low voltage and “high” current to deliver substantial sound power. Impedance is a measure of opposition to any and all forms of electric current, including alternating current (AC). Resistance, by comparison, is a strictly measure of opposition to *direct* current (DC). Like resistance, impedance is measured in the unit of the Ohm (Ω), but it is symbolized in equations by the capital letter “Z” rather than the capital letter “R”. We use the term “impedance” to describe the headphone’s opposition to current because it is primarily AC signals that headphones are normally subjected to, not DC.

Most small signal sources have high internal impedances, some much higher than the nominal 8 Ω of the headphone speakers. This is a technical way of saying that they are incapable of supplying substantial amounts of current. As the Maximum Power Transfer Theorem predicts, maximum sound power will be delivered by the headphone speakers when their impedance is “matched” to the impedance of the voltage source. The transformer does this. The transformer also helps aid the detection of small DC signals by producing inductive “kickback” every time the test lead circuit is broken, thus “amplifying” the signal by magnetically storing up electrical energy and suddenly releasing it to the headphone speakers.

As with the low-voltage AC power supply experiment, I recommend building this detector in a permanent fashion (mounting all components inside of a box, and providing nice test lead wires) so it can be easily used in the future. Constructed as such, it might look something like this:

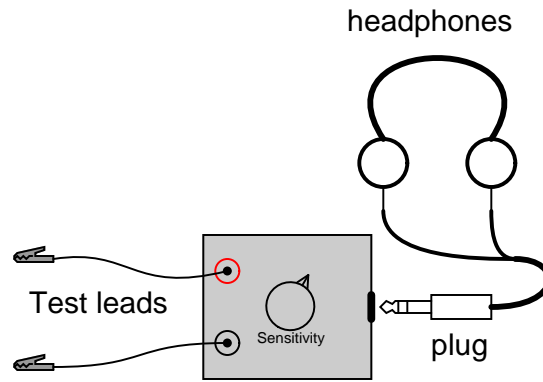

4.6 Sensing AC magnetic fields

PARTS AND MATERIALS

- Audio detector with headphones
- Electromagnet coil from relay or solenoid

What is needed for an electromagnet coil is a coil with *many* turns of wire, so as to produce the most voltage possible from induction with stray magnetic fields. The coil taken from an old relay or solenoid works well for this purpose.

CROSS-REFERENCES

Lessons In Electric Circuits, Volume 2, chapter 7: "Mixed-Frequency AC Signals"

LEARNING OBJECTIVES

- Effects of electromagnetic induction.
- Electromagnetic shielding techniques.

SCHEMATIC DIAGRAM

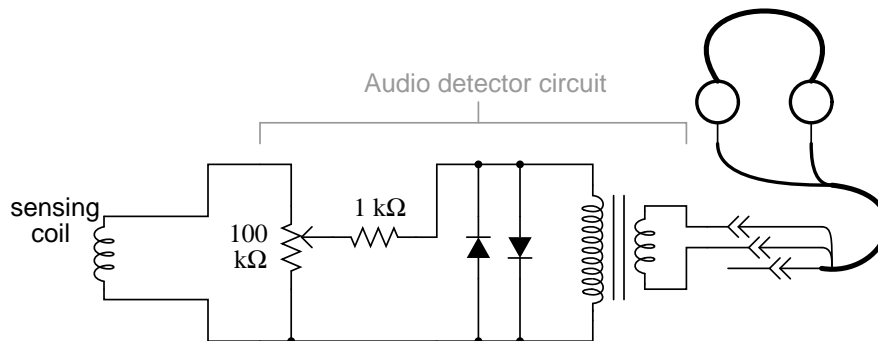

ILLUSTRATION

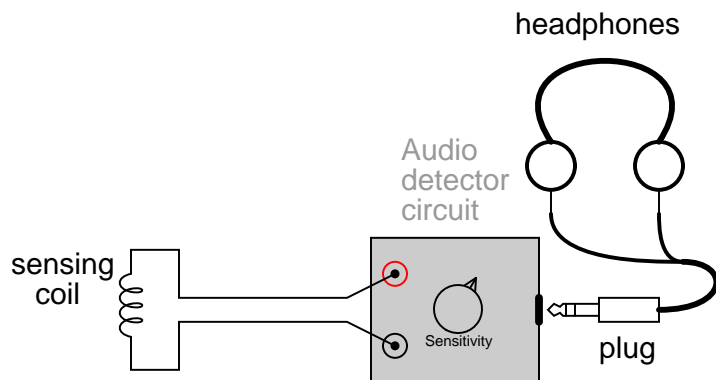

INSTRUCTIONS

Using the audio detector circuit explained earlier to detect AC voltage in the audio frequencies, a coil of wire may serve as sensor of AC magnetic fields. The voltages produced by the coil will be quite small, so it is advisable to adjust the detector's sensitivity control to "maximum."

There are many sources of AC magnetic fields to be found in the average home. Try, for instance, holding the coil close to a television screen or circuit-breaker box. The coil's orientation is every bit as important as its proximity to the source, as you will soon discover on your own! If you want to listen to more interesting tones, try holding the coil close to the motherboard of an operating computer (be careful not to "short" any connections together on the computer's circuit board with any exposed metal parts on the sensing coil!), or to its hard drive while a read/write operation is taking place.

One *very* strong source of AC magnetic fields is the home-made transformer project described earlier. Try experimenting with various degrees of "coupling" between the coils (the steel bars tightly fastened together, versus loosely fastened, versus dismantled). Another source is the variable inductor and lamp circuit described in another section of this chapter.

Note that physical contact with a magnetic field source is unnecessary: magnetic fields extend through space quite easily. You may also want to try "shielding" the coil from a strong source using various materials. Try aluminum foil, paper, sheet steel, plastic, or whatever other materials you can think of. What materials work best? Why? What angles (orientations) of coil position minimize magnetic coupling (result in a minimum of detected signal)? What does this tell us regarding inductor positioning if inter-circuit interference from other inductors is a bad thing?

Whether or not stray magnetic fields like these pose any health hazard to the human body is a hotly debated subject. One thing is clear: in today's modern society, low-level magnetic fields of all frequencies are easy to find!

4.7 Sensing AC electric fields

PARTS AND MATERIALS

- Audio detector with headphones

CROSS-REFERENCES

Lessons In Electric Circuits, Volume 2, chapter 7: "Mixed-Frequency AC Signals"

LEARNING OBJECTIVES

- Effects of electrostatic (capacitive) coupling.
- Electrostatic shielding techniques.

SCHEMATIC DIAGRAM

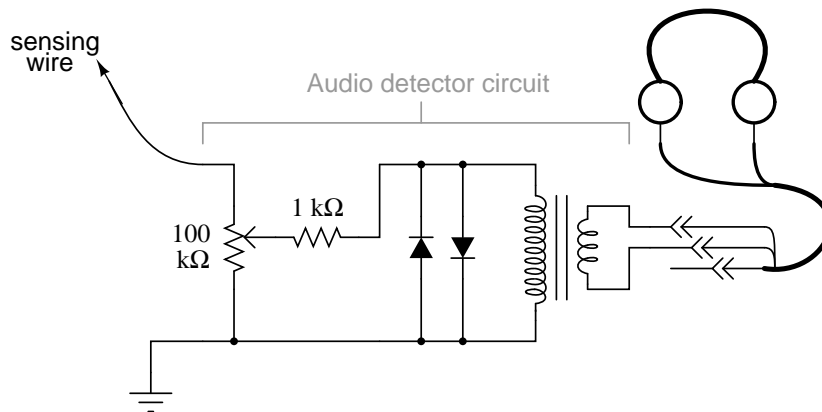

ILLUSTRATION

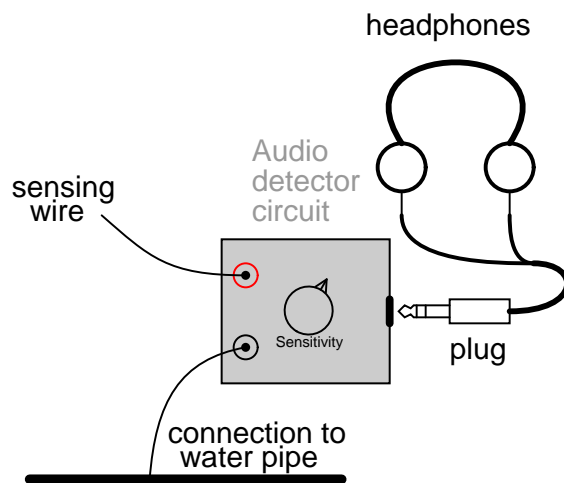

INSTRUCTIONS

"Ground" one lead of the detector to a metal object in contact with the earth (dirt). Most any water pipe or faucet in a house will suffice. Take the other lead and hold it close to an electrical appliance or lamp fixture. **Do not try to make contact with the appliance or with any conductors within!** Any AC electric fields produced by the appliance will be heard in the headphones as a buzzing tone.

Try holding the wire in different positions next to a good, strong source of electric fields. Try using a piece of aluminum foil clipped to the wire's end to maximize capacitance (and therefore its ability to intercept an electric field). Try using different types of material to "shield" the wire from an electric field source. What material(s) work best? How does this compare with the AC *magnetic* field experiment?

As with magnetic fields, there is controversy whether or not stray electric fields like these pose any health hazard to the human body.

4.8 Automotive alternator

PARTS AND MATERIALS

- Automotive alternator (one required, but two recommended)

Old alternators may be obtained for low prices at automobile wrecking yards. Many yards have alternators already removed from the automobile, for your convenience. I do *not* recommend paying full price for a new alternator, as used units cost far less money and function just as well for the purposes of this experiment.

I highly recommend using a Delco-Remy brand of alternator. This is the type used on General Motors (GMC, Chevrolet, Cadillac, Buick, Oldsmobile) vehicles. One particular model has been produced by Delco-Remy since the early 1960's with little design change. It is a *very* common unit to locate in a wrecking yard, and very easy to work with.

If you obtain two alternators, you may use one as a generator and the other as a motor. The steps needed to prepare an alternator as a three-phase generator and as a three-phase motor are the same.

CROSS-REFERENCES

Lessons In Electric Circuits, Volume 1, chapter 14: "Magnetism and Electromagnetism"

Lessons In Electric Circuits, Volume 2, chapter 10: "Polyphase AC Circuits"

LEARNING OBJECTIVES

- Effects of electromagnetism
- Effects of electromagnetic induction
- Construction of real electromagnetic machines
- Construction and application of three-phase windings

SCHEMATIC DIAGRAM

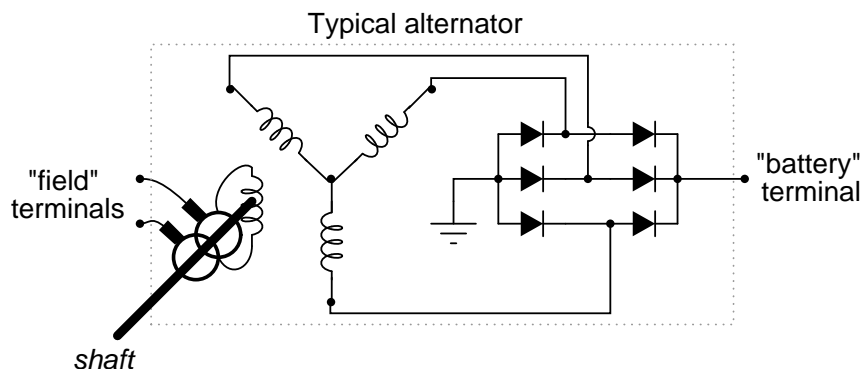

An automotive alternator is a three-phase generator with a built-in rectifier circuit consisting of six diodes. As the sheave (most people call it a "pulley") is rotated by a belt connected

to the automobile engine's crankshaft, a magnet is spun past a stationary set of three-phase windings (called the *stator*), usually connected in a Y configuration. The spinning magnet is actually an electromagnet, not a permanent magnet. Alternators are designed this way so that the magnetic field strength can be controlled, in order that output voltage may be controlled independently of rotor speed. This rotor magnet coil (called the *field coil*, or simply *field*) is energized by battery power, so that it takes a small amount of electrical power input to the alternator to get it to generate a lot of output power.

Electrical power is conducted to the rotating field coil through a pair of copper "slip rings" mounted concentrically on the shaft, contacted by stationary carbon "brushes." The brushes are held in firm contact with the slip rings by spring pressure.

Many modern alternators are equipped with built-in "regulator" circuits that automatically switch battery power on and off to the rotor coil to regulate output voltage. This circuit, if present in the alternator you choose for the experiment, is unnecessary and will only impede your study if left in place. Feel free to "surgically remove" it, just make sure you leave access to the brush terminals so that you can power the field coil with the alternator fully assembled.

ILLUSTRATION

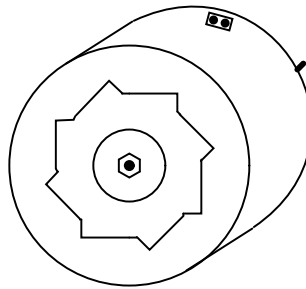

INSTRUCTIONS

First, consult an automotive repair manual on the specific details of your alternator. The documentation provided in the book you're reading now is as general as possible to accommodate different brands of alternators. You may need more specific information, and a service manual is the best place to obtain it.

For this experiment, you'll be connecting wires to the coils inside the alternator and extending them outside the alternator case, for easy connection to test equipment and circuits. Unfortunately, the connection terminals provided by the manufacturer won't suit our needs here, so you need to make your own connections.

Disassemble the unit and locate terminals for connecting to the two carbon brushes. Solder a pair of wires to these terminals (at least 20 gauge in size) and extend these wires through vent holes in the alternator case, making sure they won't get snagged on the spinning rotor when the alternator is re-assembled and used.

Locate the three-phase line connections coming from the stator windings and connect wires to them as well, extending these wires outside the alternator case through some vent holes. Use the largest gauge wire that is convenient to work with for these wires, as they may be carrying substantial current. As with the field wires, route them in such a way that the rotor will turn freely with the alternator reassembled. The stator winding line terminals are easy

to locate: the three of them connect to three terminals on the diode assembly, usually with "ring-lug" terminals soldered to the ends of the wires.

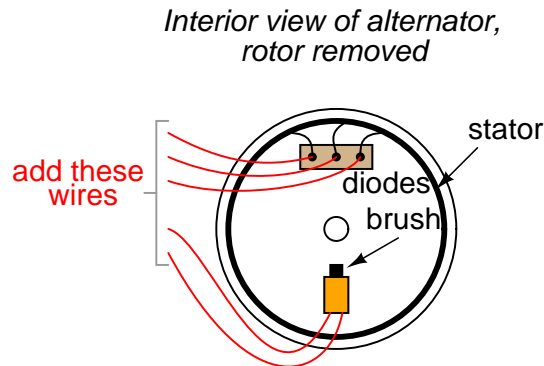

I recommend that you solder ring-lug terminals to your wires, and attach them underneath the terminal nuts along with the stator wire ends, so that each diode block terminal is securing two ring lugs.

Re-assemble the alternator, taking care to secure the carbon brushes in a retracted position so that the rotor doesn't damage them upon re-insertion. On Delco-Remy alternators, a small hole is provided on the back case half, and also at the front of the brush holder assembly, through which a paper clip or thin-gauge wire may be inserted to hold the brushes back against their spring pressure. Consult the service manual for more details on alternator assembly.

When the alternator has been assembled, try spinning the shaft and listen for any sounds indicative of colliding parts or snagged wires. If there is any such trouble, take it apart again and correct whatever is wrong.

If and when it spins freely as it should, connect the two "field" wires to a 6-volt battery. Connect an voltmeter to any two of the three-phase line connections:

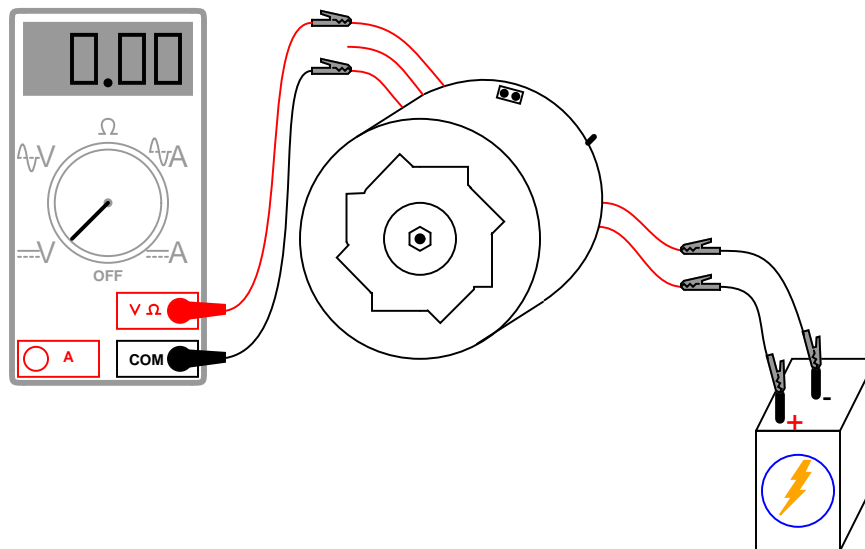

With the multimeter set to the "DC volts" function, *slowly* rotate the alternator shaft. The voltmeter reading should alternate between positive and negative as the shaft is turned: a demonstration of very slow alternating voltage (AC voltage) being generated. If this test is successful, switch the multimeter to the "AC volts" setting and try again. Try spinning the shaft slow and fast, comparing voltmeter readings between the two conditions.

Short-circuit any two of the three-phase line wires and try spinning the alternator. What you should notice is that the alternator shaft becomes more difficult to spin. The heavy electrical load you've created via the short circuit causes a heavy mechanical load on the alternator, as mechanical energy is converted into electrical energy.

Now, try connecting 12 volts DC to the field wires. Repeat the DC voltmeter, AC voltmeter, and short-circuit tests described above. What difference(s) do you notice?

Find some sort of polarity-insensitive 6 or 12 volts loads, such as small incandescent lamps, and connect them to the three-phase line wires. Wrap a thin rope or heavy string around the groove of the sheave ("pulley") and spin the alternator rapidly, and the loads should function.

If you have a second alternator, modify it as you modified the first one, connecting five of your own wires to the field brushes and stator line terminals, respectively. You can then use it as a three-phase motor, powered by the first alternator.

Connect each of the three-phase line wires of the first alternator to the respective wires of the second alternator. Connect the field wires of one alternator to a 6 volt battery. This alternator will be the generator. Wrap rope around the sheave in preparation to spin it. Take the two field wires of the second alternator and short them together. This alternator will be the motor:

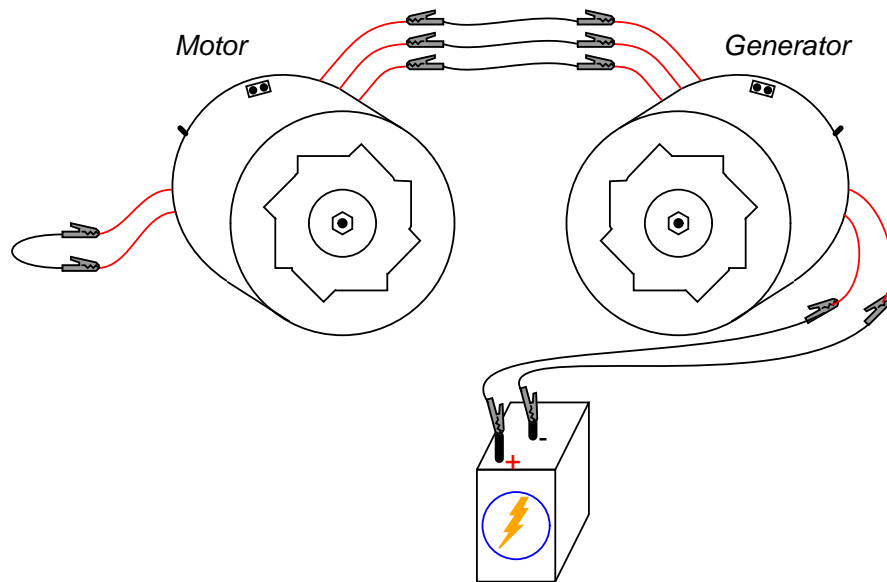

Spin the generator shaft while watching the motor shaft's rotation. Try reversing any *two* of the three-phase line connections between the two units and spin the generator again. What is different this time?

Connect the field wires of the motor unit to the a 6 volt battery (you may parallel-connect this field with the field of the generator unit, across the same battery terminals, if the battery

is strong enough to deliver the several amps of current both coils will draw together). This will magnetize the rotor of the motor. Try spinning the generator again and note any differences in operation.

In the first motor setup, where the field wires were simple shorted together, the motor was functioning as an *induction motor*. In the second setup, where the motor's rotor was magnetized, it functioned as a *synchronous motor*.

If you are feeling particularly ambitious and are skilled in metal fabrication techniques, you may make your own high-power generator platform by connecting the modified alternator to a bicycle. I've built an arrangement that looks like this:

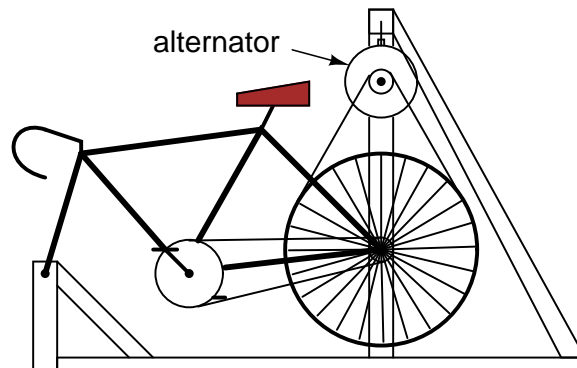

The rear wheel drives the generator sheave with a *long v-belt*. This belt also supports the rear of the bicycle, maintaining a constant tension when a rider is pedaling the bicycle. The generator hangs from a steel support structure (I used welded 2-inch square tubing, but a frame could be made out of lumber). Not only is this machine practical, but it is reliable enough to be used as an exercise machine, and it is inexpensive to make:



You can see a bank of three 12-volt "RV" light bulbs behind the bicycle unit (in the lower-left corner of the photograph), which I use for a load when riding the bicycle as an exercise machine. A set of three switches is mounted at the front of the bicycle, where I can turn loads on and off while riding.

By rectifying the three-phase AC power produced, it is possible to have the alternator power its own field coil with DC voltage, eliminating the need for a battery. However, some indepen-

dent source of DC voltage will still be necessary for start-up, as the field coil must be energized *before* any AC power can be produced.

4.9 Induction motor

PARTS AND MATERIALS

- **AC power source: 120VAC**
- Capacitor, 3.3 μF (or 2.2 μF) 120VAC or 350VDC, non-polarized
- 15 to 25 watt incandescent lamp or 820 Ω 25 watt resistors
- #32 AWG magnet wire
- wooden board approx. 5 in. square.
- AC line cord with plug
- 1.75 inch dia. cardboard tubing (toilet paper roll)
- lamp socket
- **AC power source: 220VAC**
- Capacitor, 1.5 μF 240VAC or 680VDC, non-polarized
- 25 to 40 watt incandescent lamp or 820 Ω 25 watt resistors
- #32 AWG magnet wire
- wooden board approx. 15 cm. square.
- AC line cord with plug
- 4.5 to 5 cm. dia. cardboard tubing.
- lamp socket

CROSS-REFERENCES

Lessons In Electric Circuits, Volume 2, chapter 13: "AC motors", "Single Phase induction motors", "Permanent split-capacitor motor".

LEARNING OBJECTIVES

- To build an AC permanent split-capacitor induction motor.
- To illustrate the simplicity of the AC induction motor.

SCHEMATIC DIAGRAM

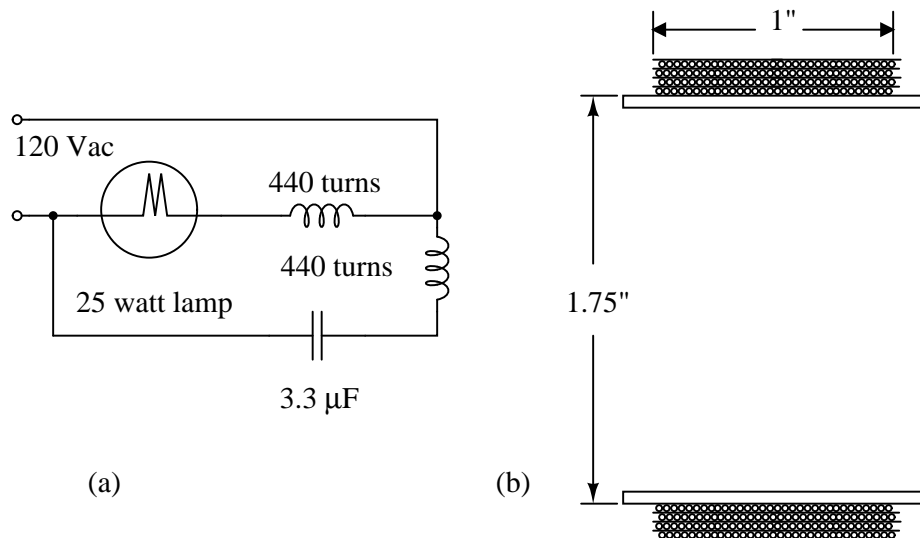
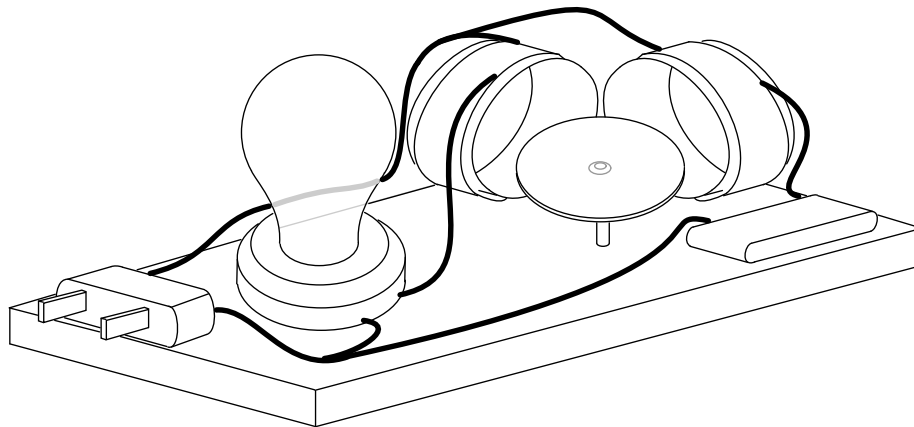
**ILLUSTRATION****INSTRUCTIONS**

There are two parts lists to choose from depending upon the availability of 120VAC or 220VAC. Choose the one for your location. This set of instructions is for the 120VAC version.

This is a simplified version of a "permanent capacitor split-phase induction motor". By simplified, we mean the coils only requires a few hundred turns instead of a few thousand. This is easier to wind. Though, the larger few thousand turns model is impressive. There are two stator coils as shown in the illustration above. Approximately 440 turns of #32 AWG (American wire gauge) enameled magnet wire are wound over a one inch length of a slightly longer section of 1.75 inch diameter toilet paper tube. To avoid counting the turns, close-wind four layers of magnet wire over a one inch width of the tube. See (b) above. Leave a few inches of magnet wire for the leads. Tape the beginning lead near the end of the tube so that the windings will cover and anchor the tape. Do not cut the final width of the cardboard tube until

the winding is finished. Close wind a single layer. Tape or cement the first layer to prevent unwinding before proceeding to the second layer. Though it is possible to wind additional layers directly over existing layers, consider applying tape or paper between the layers as shown in schematic (b). After four layers are wound, glue the windings in place.

If close winding four layers of magnet wire is too difficult, scramble wind 440 turns of the magnet wire over the end of the cardboard tube. However, the close-wound style coil mounts more easily to the baseboard. Keep the windings within a one inch length.

Cut the finished winding from the end of the cardboard tube with a razor knife allowing the form to extend a little beyond the winding. Strip the enamel from an inch off the ends of the pair of lead wires with sandpaper. Splice the bare ends to heavier gauge insulated hook-up wire. Solder the splice. Insulate with tape or heat-shrink tubing. Secure the splice to the coil body. Then proceed with a second identical coil.

Refer to both the schematic diagram and the illustration for assembly. Note that the coils are mounted at right angles. They may be cemented to an insulating baseboard like wood. The 25 watt lamp is wired in series with one coil. This limits the current flowing through the coil. The lamp is a substitute for an $820\ \Omega$ power resistor. The capacitor is wired in series with the other coil. It also limits the current through the coil. In addition, it provides a leading phase shift of the current with respect to voltage. The schematic and illustration show no power switch or fuse. Add these if desired.

The rotor must be made of a ferromagnetic material like a steel can lid or bottle cap. The illustration below shows how to make the rotor. Select a circular rotor either smaller than the coil forms or a little larger. Use geometry to locate and mark the center. The center needs to be dimpled. Select an eighth inch diameter (a few mm) nail (a) and file or grind the point round as shown at (b). Place the rotor atop a piece of soft wood (c) and hammer the rounded point into the center (d). Practice on a piece of similar scrap metal. Take care not to pierce the rotor. A dished rotor (f) or a lid (g) balance better than the flat rotor (e). The pivot point (e) may be a straight pin driven through a movable wooden pedestal, or through the main board. The tip of a ball-point pen also works. If the rotor does not balance atop the pivot, remove metal from the heavy side.

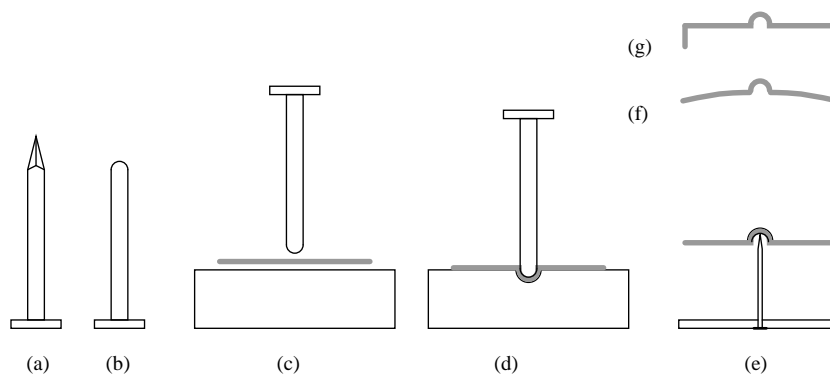

Double check the wiring. Check that any bare wire has been insulated. The circuit may be powered-up without the rotor. The lamp should light. Both coils will warm within a few minutes. Excessive heating means that a lower wattage (higher resistance) lamp and a lower value capacitor should be substituted in series with the respective coils.

Place the rotor atop the pivot and move it between both coils. It should spin. The closer it is, the faster it should spin. Both coils should be warm, indicating power. Try different size and style rotors. Try a small rotor on the opposite side of the coils compared to the illustration.

For lack of #32 AWG magnet wire try 440 turns of slightly a larger diameter (lesser AWG number) wire. This will require more than 4 layers for the required turns. A night-light fixture might be less expensive than the full-size lamp socket illustrated. Though night-light bulbs are too low a wattage at 3 or 7 watts, 15 watt bulbs fit the socket.

4.10 Phase shift

PARTS AND MATERIALS

- Low-voltage AC power supply
- Two capacitors, $0.1 \mu\text{F}$ each, non-polarized (Radio Shack catalog # 272-135)
- Two $27 \text{ k}\Omega$ resistors

I recommend ceramic disk capacitors, because they are insensitive to polarity (non-polarized), inexpensive, and durable. Avoid capacitors with any kind of polarity marking, as these will be destroyed when powered by AC!

CROSS-REFERENCES

Lessons In Electric Circuits, Volume 2, chapter 1: "Basic AC Theory"

Lessons In Electric Circuits, Volume 2, chapter 4: "Reactance and Impedance – Capacitive"

LEARNING OBJECTIVES

- How out-of-phase AC voltages do not add algebraically, but according to vector (phasor) arithmetic

SCHEMATIC DIAGRAM

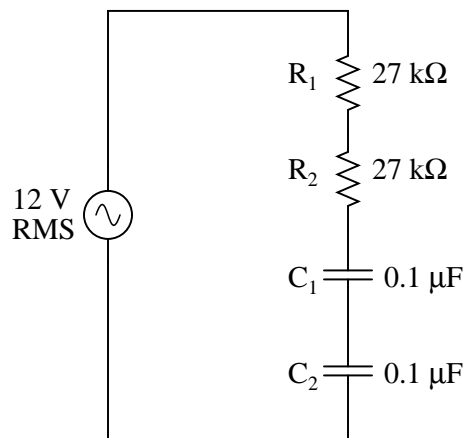

ILLUSTRATION

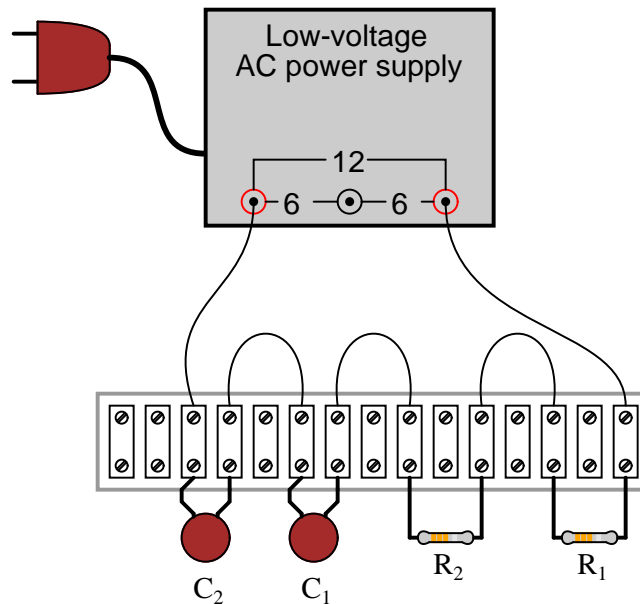

INSTRUCTIONS

Build the circuit and measure voltage drops across each component with an AC voltmeter. Measure total (supply) voltage with the same voltmeter. You will discover that the voltage drops do *not* add up to equal the total voltage. This is due to phase shifts in the circuit: voltage dropped across the capacitors is out-of-phase with voltage dropped across the resistors, and thus the voltage drop figures do not add up as one might expect. Taking phase angle into consideration, they *do* add up to equal the total, but a voltmeter doesn't provide phase angle measurements, only amplitude.

Try measuring voltage dropped across both resistors at once. This voltage drop *will* equal the sum of the voltage drops measured across each resistor separately. This tells you that both the resistors' voltage drop waveforms are in-phase with each other, since they add simply and directly.

Measure voltage dropped across both capacitors at once. This voltage drop, like the drop measured across the two resistors, *will* equal the sum of the voltage drops measured across each capacitor separately. Likewise, this tells you that both the capacitors' voltage drop waveforms are in-phase with each other.

Given that the power supply frequency is 60 Hz (household power frequency in the United States), calculate impedances for all components and determine all voltage drops using Ohm's Law ($E=IZ$; $I=E/Z$; $Z=E/I$). The polar magnitudes of the results should closely agree with your voltmeter readings.

COMPUTER SIMULATION

Schematic with SPICE node numbers:

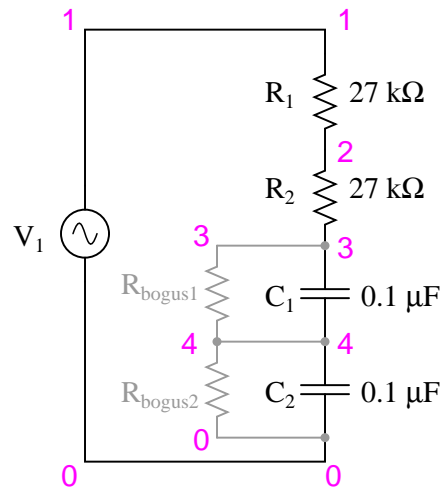

The two large-value resistors R_{bogus1} and R_{bogus1} are connected across the capacitors to provide a DC path to ground in order that SPICE will work. This is a "fix" for one of SPICE's quirks, to avoid it from seeing the capacitors as open circuits in its analysis. These two resistors are entirely unnecessary in the real circuit.

Netlist (make a text file containing the following text, verbatim):

```
phase shift
v1 1 0 ac 12 sin
r1 1 2 27k
r2 2 3 27k
c1 3 4 0.1u
c2 4 0 0.1u
rbogus1 3 4 1e9
rbogus2 4 0 1e9
.ac lin 1 60 60
* Voltage across each component:
.print ac v(1,2) v(2,3) v(3,4) v(4,0)
* Voltage across pairs of similar components
.print ac v(1,3) v(3,0)
.end
```

4.11 Sound cancellation

PARTS AND MATERIALS

- Low-voltage AC power supply
- Two audio speakers
- Two $220\ \Omega$ resistors

Large, low-frequency ("woofer") speakers are most appropriate for this experiment. For optimum results, the speakers should be identical and mounted in enclosures.

CROSS-REFERENCES

Lessons In Electric Circuits, Volume 2, chapter 1: "Basic AC Theory"

LEARNING OBJECTIVES

- How phase shift can cause waves to either reinforce or interfere with each other
- The importance of speaker "phasing" in stereo systems

SCHEMATIC DIAGRAM

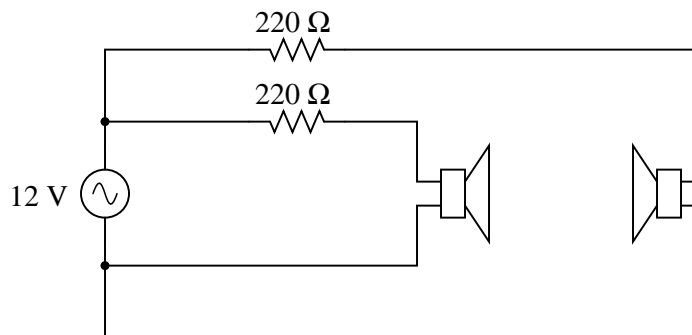

ILLUSTRATION

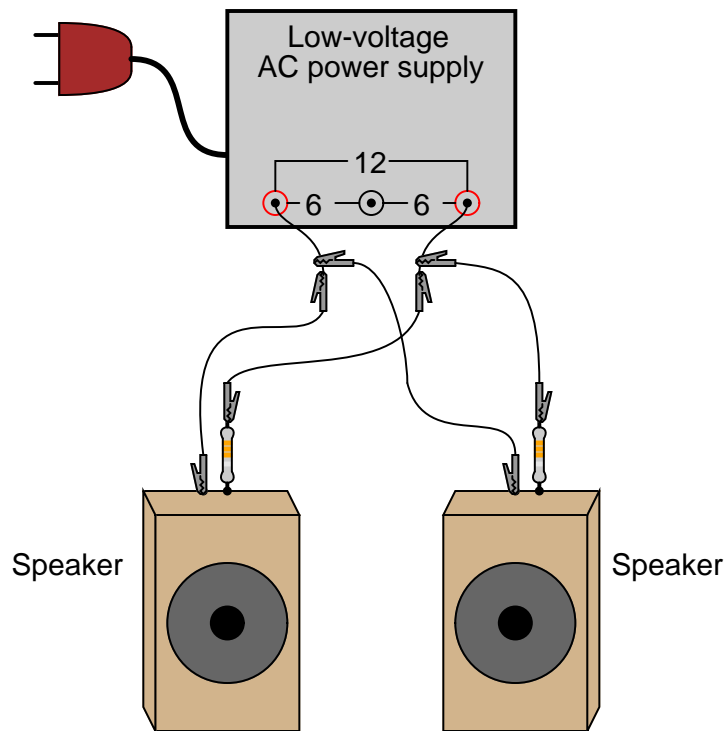

INSTRUCTIONS

Connect each speaker to the low-voltage AC power supply through a $220\ \Omega$ resistor. The resistor limits the amount of power delivered to each speaker by the power supply. A low-pitched, 60-Hertz tone should be heard from the speakers. If the tone sounds too loud, use higher-value resistors.

With both speakers connected and producing sound, position them so that they are only a foot or two away, facing toward each other. Listen to the volume of the 60-Hertz tone. Now, reverse the connections (the "polarity") of just *one* of the speakers and note the volume again. Try switching the polarity of one speaker back and forth from original to reversed, comparing volume levels each way. What do you notice?

By reversing wire connections to one speaker, you are reversing the *phase* of that speaker's sound wave in reference to the other speaker. In one mode, the sound waves will reinforce one another for a strong volume. In the other mode, the sound waves will destructively interfere, resulting in diminished volume. This phenomenon is common to *all* wave events: sound waves, electrical signals (voltage "waves"), waves in water, and even light waves!

Multiple speakers in a stereo sound system must be properly "phased" so that their respective sound waves don't cancel each other, leaving less total sound level for the listener(s) to hear. So, even in an AC system where there really is no such thing as constant "polarity," the sequence of wire connections may make a significant difference in system performance.

This principle of volume reduction by destructive interference may be exploited for noise cancellation. Such systems sample the waveform of the ambient noise, then produce an iden-

tical sound signal 180° out of phase with the noise. When the two sound signals meet, they cancel each other out, ideally eliminating all the noise. As one might guess, this is much easier accomplished with noise sources of steady frequency and amplitude. Cancellation of random, broad-spectrum noise is very difficult, as some sort of signal-processing circuit must sample the noise and generate precisely the right amount of cancellation sound at just the right time in order to be effective.

4.12 Musical keyboard as a signal generator

PARTS AND MATERIALS

- Electronic "keyboard" (musical)
- "Mono" (not stereo) headphone-type plug
- Impedance matching transformer (1k Ω to 8 Ω ratio; Radio Shack catalog # 273-1380)
- 10 k Ω resistor

In this experiment, you'll learn how to use an electronic musical keyboard as a source of variable-frequency AC voltage signals. You need not purchase an expensive keyboard for this – but one with at least a few dozen "voice" selections (piano, flute, harp, etc.) would be good. The "mono" plug will be plugged into the headphone jack of the musical keyboard, so get a plug that's the correct size for the keyboard.

The "impedance matching transformer" is a small-size transformer easily obtained from an electronics supply store. One may be scavenged from a small, junk radio: it connects between the speaker and the circuit board (amplifier), so is easily identifiable by location. The primary winding is rated in ohms of impedance (1000 Ω), and is usually center-tapped. The secondary winding is 8 Ω and not center-tapped. These impedance figures are not the same as DC resistance, so don't expect to read 1000 Ω and 8 Ω with your ohmmeter – however, the 1000 Ω winding will read *more* resistance than the 8 Ω winding, because it has more turns.

If such a transformer cannot be obtained for the experiment, a regular 120V/6V step-down power transformer works fairly well, too.

CROSS-REFERENCES

Lessons In Electric Circuits, Volume 2, chapter 1: "Basic AC Theory"

Lessons In Electric Circuits, Volume 2, chapter 7: "Mixed-Frequency AC Signals"

LEARNING OBJECTIVES

- Difference between amplitude and frequency
- Measuring AC voltage, current with a meter
- Transformer operation, step-up

SCHEMATIC DIAGRAM

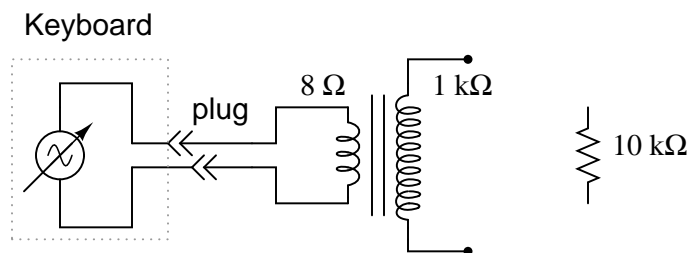

ILLUSTRATION

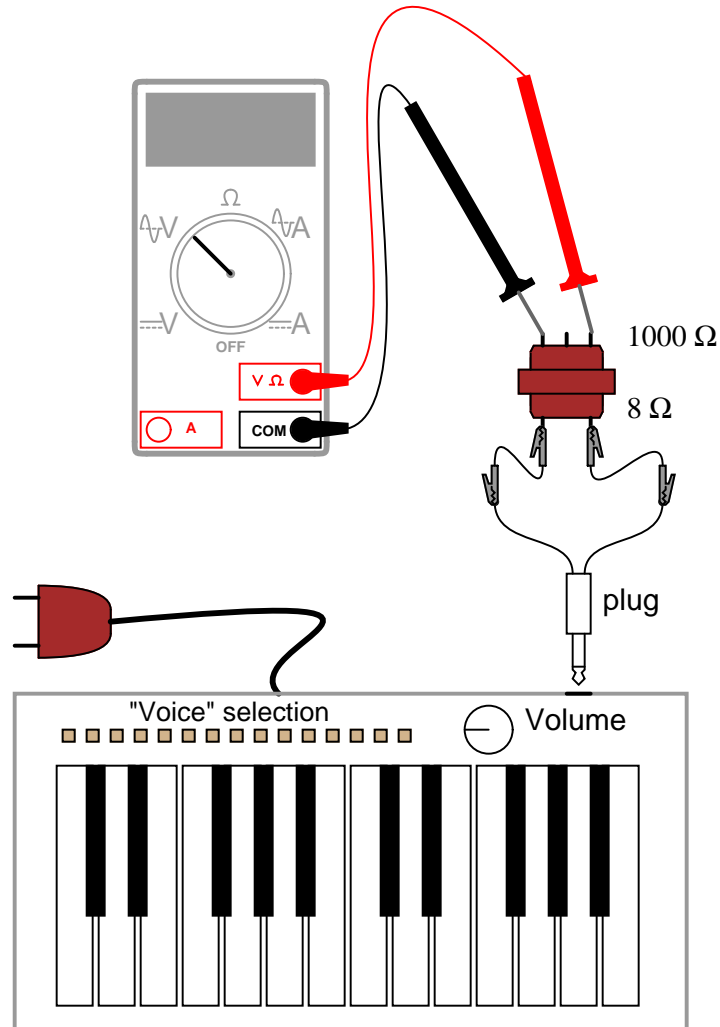

INSTRUCTIONS

Normally, a student of electronics in a school would have access to a device called a *signal generator*, or *function generator*, used to make variable-frequency voltage waveforms to power AC circuits. An inexpensive electronic keyboard is a cheaper alternative to a regular signal generator, and provides features that most signal generators cannot match, such as producing *mixed-frequency* waves.

To "tap in" to the AC voltage produced by the keyboard, you'll need to insert a plug into the headPHONE jack (sometimes just labeled "phone" on the keyboard) complete with two wires for connection to circuits of your own design. When you insert the plug into the jack, the normal speaker built in to the keyboard will be disconnected (assuming the keyboard is equipped with one), and the signal that used to power that speaker will be available at the plug wires. In

this particular experiment, I recommend using the keyboard to power the $8\ \Omega$ side of an audio "output" transformer to step up voltage to a higher level. If using a power transformer instead of an audio output transformer, connect the keyboard to the low-voltage winding so that it operates as a step-up device. Keyboards produce very low voltage signals, so there is no shock hazard in this experiment.

Using an inexpensive Yamaha keyboard, I have found that the "panflute" voice setting produces the truest sine-wave waveform. This waveform, or something close to it (flute, for example), is recommended to start experimenting with since it is relatively free of harmonics (many waveforms mixed together, of integer-multiple frequency). Being composed of just one frequency, it is a less complex waveform for your multimeter to measure. Make sure the keyboard is set to a mode where the note will be sustained as any key is held down – otherwise, the amplitude (voltage) of the waveform will be constantly changing (high when the key is first pressed, then decaying rapidly to zero).

Using an AC voltmeter, read the voltage direct from the headphone plug. Then, read the voltage as stepped up by the transformer, noting the step ratio. If your multimeter has a "frequency" function, use it to measure the frequency of the waveform produced by the keyboard. Try different notes on the keyboard and record their frequencies. Do you notice a pattern in frequency as you activate different notes, especially keys that are similar to each other (notice the 12-key black-and-white pattern repeated on the keyboard from left to right)? If you don't mind making marks on your keyboard, write the frequencies in Hertz in black ink on the white keys, near the tops where fingers are less likely to rub the numbers off.

Ideally, there should be no change in signal amplitude (voltage) as different frequencies (notes on the keyboard) are tried. If you adjust the volume up and down, you should discover that changes in amplitude should have little or no impact on frequency measurement. Amplitude and frequency are two completely independent aspects of an AC signal.

Try connecting the keyboard output to a $10\ \text{k}\Omega$ load resistance (through the headphone plug), and measure AC current with your multimeter. If your multimeter has a frequency function, you can measure the frequency of this current as well. It should be the same as for the voltage for any given note (keyboard key).

4.13 PC Oscilloscope

PARTS AND MATERIALS

- IBM-compatible personal computer with sound card, running Windows 3.1 or better
- Winscope software, downloaded free from internet
- Electronic "keyboard" (musical)
- "Mono" (not stereo) headphone-type plug for keyboard
- "Mono" (not stereo) headphone-type plug for computer sound card microphone input
- 10 k Ω potentiometer

The Winscope program I've used was written by Dr. Constantin Zeldovich, for free personal and academic use. It plots waveforms on the computer screen in response to AC voltage signals interpreted by the sound card microphone input. A similar program, called *Oscope*, is made for the Linux operating system. If you don't have access to either software, you may use the "sound recorder" utility that comes stock with most versions of Microsoft Windows to display crude waveshapes.

CROSS-REFERENCES

Lessons In Electric Circuits, Volume 2, chapter 7: "Mixed-Frequency AC Signals"

Lessons In Electric Circuits, Volume 2, chapter 12: "AC Metering Circuits"

LEARNING OBJECTIVES

- Computer use
- Basic oscilloscope function

SCHEMATIC DIAGRAM

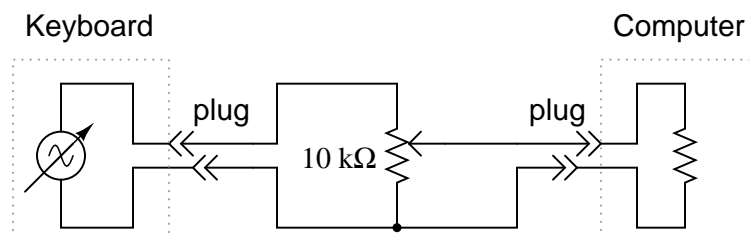

ILLUSTRATION

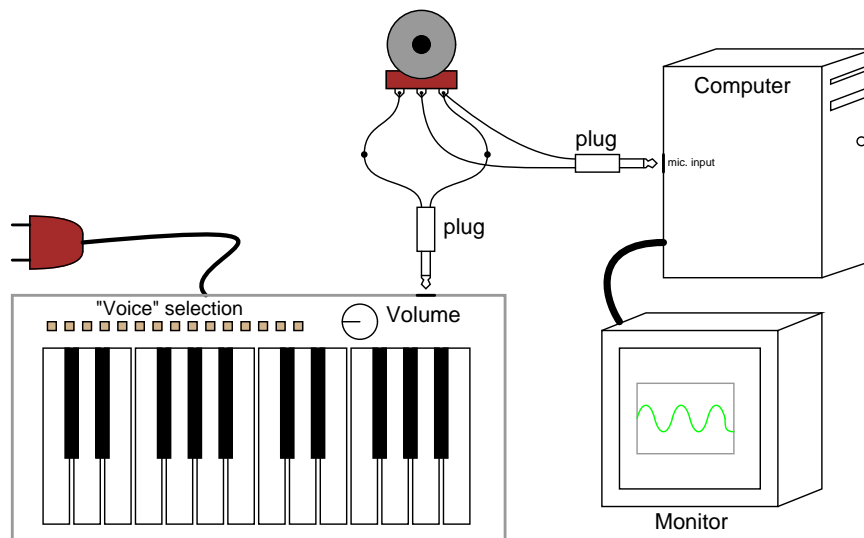

INSTRUCTIONS

The oscilloscope is an indispensable test instrument for the electronics student and professional. No serious electronics lab should be without one (or two!). Unfortunately, commercial oscilloscopes tend to be expensive, and it is almost impossible to design and build your own without another oscilloscope to troubleshoot it! However, the sound card of a personal computer is capable of "digitizing" low-voltage AC signals from a range of a few hundred Hertz to several thousand Hertz with respectable resolution, and free software is available for displaying these signals in oscilloscope form on the computer screen. Since most people either have a personal computer or can obtain one for less cost than an oscilloscope, this becomes a viable alternative for the experimenter on a budget.

One word of caution: **you can cause significant hardware damage to your computer if signals of excessive voltage are connected to the sound card's microphone input!** The AC voltages produced by a musical keyboard are too low to cause damage to your computer through the sound card, but other voltage sources might be hazardous to your computer's health. Use this "oscilloscope" at your own risk!

Using the keyboard and plug arrangement described in the previous experiment, connect the keyboard output to the outer terminals of a 10 k Ω potentiometer. Solder two wires to the connection points on the sound card microphone input plug, so that you have a set of "test leads" for the "oscilloscope." Connect these test leads to the potentiometer: between the middle terminal (the wiper) and either of the outer terminals.

Start the Winscope program and click on the "arrow" icon in the upper-left corner (it looks like the "play" arrow seen on tape player and CD player control buttons). If you press a key on the musical keyboard, you should see some kind of waveform displayed on the screen. Choose the "panflute" or some other flute-like voice on the musical keyboard for the best sine-wave shape. If the computer displays a waveform that looks kind of like a square wave, you need to adjust the potentiometer for a lower-amplitude signal. Almost any waveshape will be "clipped" to look like a square wave if it exceeds the amplitude limit of the sound card.

Test different instrument "voices" on the musical keyboard and note the different waveshapes. Note how complex some of the waveshapes are, compared to the panflute voice. Experiment with the different controls in the Winscope window, noting how they change the appearance of the waveform.

As a test instrument, this "oscilloscope" is quite poor. It has almost no capability to make precision measurements of voltage, although its frequency precision is surprisingly good. It is *very* limited in the ranges of voltage and frequency it can display, relegating it to the analysis of low- and mid-range audio tones. I have had very little success getting the "oscilloscope" to display good square waves, presumably because of its limited frequency response. Also, the coupling capacitor found in sound card microphone input circuits prevents it from measuring DC voltage: it is as though the "AC coupling" feature of a normal oscilloscope were stuck "on."

Despite these shortcomings, it is useful as a demonstration tool, and for initial explorations into waveform analysis for the beginning student of electronics. For those who are interested, there are several professional-quality oscilloscope adapter devices manufactured for personal computers whose performance is far beyond that of a sound card, and they are typically sold at less cost than a complete stand-alone oscilloscope (around \$400, year 2002). Radio Shack sells one made by Velleman, catalog # 910-3914. Having a computer serve as the display medium brings many advantages, not the least of which is the ability to easily store waveform pictures as digital files.

4.14 Waveform analysis

PARTS AND MATERIALS

- IBM-compatible personal computer with sound card, running Windows 3.1 or better
- Winscope software, downloaded free from internet
- Electronic "keyboard" (musical)
- "Mono" (not stereo) headphone-type plug for keyboard
- "Mono" (not stereo) headphone-type plug for computer sound card microphone input, with wires for connecting to voltage sources
- 10 k Ω potentiometer

Parts and equipment for this experiment are identical to those required for the "PC oscilloscope" experiment.

CROSS-REFERENCES

Lessons In Electric Circuits, Volume 2, chapter 7: "Mixed-Frequency AC Signals"

LEARNING OBJECTIVES

- Understand the difference between time-domain and frequency-domain plots
- Develop a qualitative sense of Fourier analysis

SCHEMATIC DIAGRAM

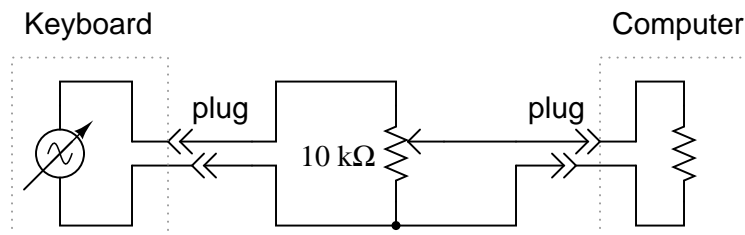

ILLUSTRATION

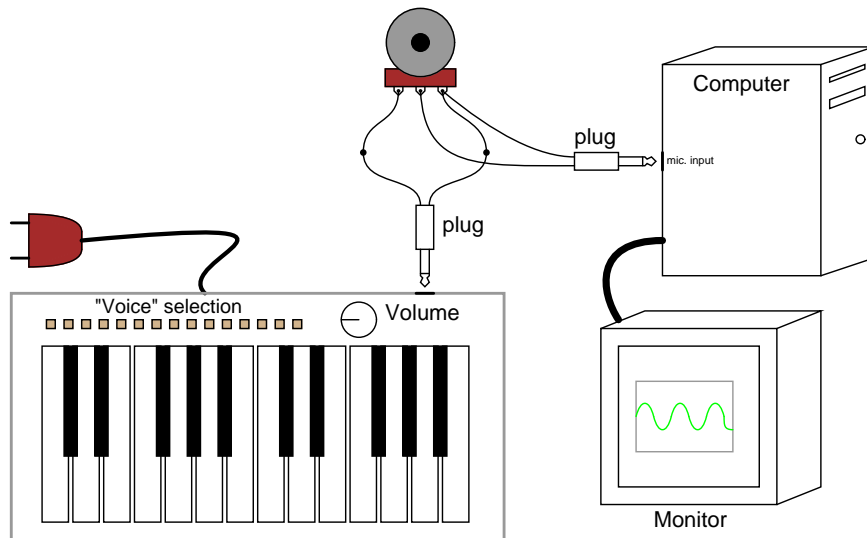

INSTRUCTIONS

The Winscope program comes with another feature other than the typical "time-domain" oscilloscope display: "frequency-domain" display, which plots amplitude (vertical) over frequency (horizontal). An oscilloscope's "time-domain" display plots amplitude (vertical) over time (horizontal), which is fine for displaying waveshape. However, when it is desirable to see the harmonic constituency of a complex wave, a frequency-domain plot is the best tool.

If using Winscope, click on the "rainbow" icon to switch to frequency-domain mode. Generate a sine-wave signal using the musical keyboard (panflute or flute voice), and you should see a single "spike" on the display, corresponding to the amplitude of the single-frequency signal. Moving the mouse cursor beneath the peak should result in the frequency being displayed numerically at the bottom of the screen.

If two notes are activated on the musical keyboard, the plot should show two distinct peaks, each one corresponding to a particular note (frequency). Basic chords (three notes) produce three spikes on the frequency-domain plot, and so on. Contrast this with normal oscilloscope (time-domain) plot by clicking once again on the "rainbow" icon. A musical chord displayed in time-domain format is a very complex waveform, but is quite simple to resolve into constituent notes (frequencies) on a frequency-domain display.

Experiment with different instrument "voices" on the musical keyboard, correlating the time-domain plot with the frequency-domain plot. Waveforms that are symmetrical above and below their centerlines contain only odd-numbered harmonics (odd-integer multiples of the base, or *fundamental* frequency), while nonsymmetrical waveforms contain even-numbered harmonics as well. Use the cursor to locate the specific frequency of each peak on the plot, and a calculator to determine whether each peak is even- or odd-numbered.

4.15 Inductor-capacitor "tank" circuit

PARTS AND MATERIALS

- Oscilloscope
- Assortment of non-polarized capacitors (0.1 μF to 10 μF)
- Step-down power transformer (120V / 6 V)
- 10 k Ω resistors
- Six-volt battery

The power transformer is used simply as an inductor, with only one winding connected. The unused winding should be left open. A simple iron core, single-winding inductor (sometimes known as a *choke*) may also be used, but such inductors are more difficult to obtain than power transformers.

CROSS-REFERENCES

Lessons In Electric Circuits, Volume 2, chapter 6: "Resonance"

LEARNING OBJECTIVES

- How to build a resonant circuit
- Effects of capacitor size on resonant frequency
- How to produce antiresonance

SCHEMATIC DIAGRAM

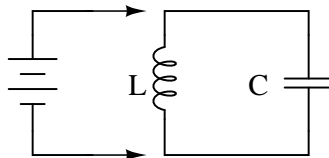

ILLUSTRATION

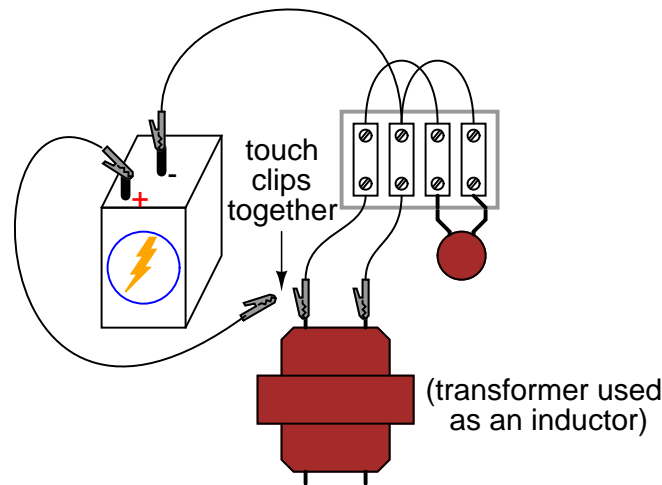

INSTRUCTIONS

If an inductor and a capacitor are connected in parallel with each other, and then briefly energized by connection to a DC voltage source, oscillations will ensue as energy is exchanged from the capacitor to inductor and vice versa. These oscillations may be viewed with an oscilloscope connected in parallel with the inductor/capacitor circuit. Parallel inductor/capacitor circuits are commonly known as *tank circuits*.

Important note: I recommend *against* using a PC/sound card as an oscilloscope for this experiment, because very high voltages can be generated by the inductor when the battery is disconnected (inductive "kickback"). These high voltages will surely damage the sound card's input, and perhaps other portions of the computer as well.

A tank circuit's natural frequency, called the *resonant frequency*, is determined by the size of the inductor and the size of the capacitor, according to the following equation:

$$f_{\text{resonant}} = \frac{1}{2\pi \sqrt{LC}}$$

Many small power transformers have primary (120 volt) winding inductances of approximately 1 H. Use this figure as a rough estimate of inductance for your circuit to calculate expected oscillation frequency.

Ideally, the oscillations produced by a tank circuit continue indefinitely. Realistically, oscillations will decay in amplitude over the course of several cycles due to the resistive and magnetic losses of the inductor. Inductors with a high "Q" rating will, of course, produce longer-lasting oscillations than low-Q inductors.

Try changing capacitor values and noting the effect on oscillation frequency. You might notice changes in the duration of oscillations as well, due to capacitor size. Since you know how to calculate resonant frequency from inductance and capacitance, can you figure out a way to calculate inductor inductance from known values of circuit capacitance (as measured by a capacitance meter) and resonant frequency (as measured by an oscilloscope)?

Resistance may be intentionally added to the circuit – either in series or parallel – for the express purpose of dampening oscillations. This effect of resistance dampening tank circuit

oscillation is known as *antiresonance*. It is analogous to the action of a shock absorber in dampening the bouncing of a car after striking a bump in the road.

COMPUTER SIMULATION

Schematic with SPICE node numbers:

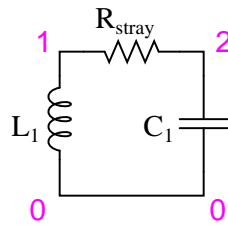

R_{stray} is placed in the circuit to dampen oscillations and produce a more realistic simulation. A lower R_{stray} value causes longer-lived oscillations because less energy is dissipated. Eliminating this resistor from the circuit results in endless oscillation.

Netlist (make a text file containing the following text, verbatim):

```
tank circuit with loss
l1 1 0 1 ic=0
rstray 1 2 1000
c1 2 0 0.1u ic=6
.tran 0.1m 20m uic
.plot tran v(1,0)
.end
```

4.16 Signal coupling

PARTS AND MATERIALS

- 6 volt battery
- One capacitor, 0.22 μF (Radio Shack catalog # 272-1070 or equivalent)
- One capacitor, 0.047 μF (Radio Shack catalog # 272-134 or equivalent)
- Small "hobby" motor, permanent-magnet type (Radio Shack catalog # 273-223 or equivalent)
- Audio detector with headphones
- Length of telephone cable, several feet long (Radio Shack catalog # 278-872)

Telephone cable is also available from hardware stores. Any unshielded multiconductor cable will suffice for this experiment. Cables with thin conductors (telephone cable is typically 24-gauge) produce a more pronounced effect.

CROSS-REFERENCES

Lessons In Electric Circuits, Volume 2, chapter 7: "Mixed-Frequency AC Signals"

Lessons In Electric Circuits, Volume 2, chapter 8: "Filters"

LEARNING OBJECTIVES

- How to "couple" AC signals and block DC signals to a measuring instrument
- How stray coupling happens in cables
- Techniques to minimize inter-cable coupling

SCHEMATIC DIAGRAM

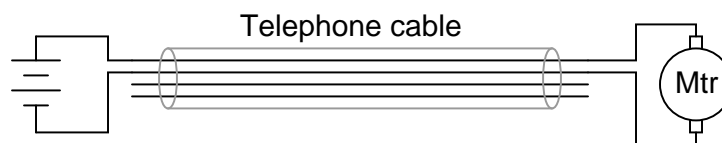

ILLUSTRATION

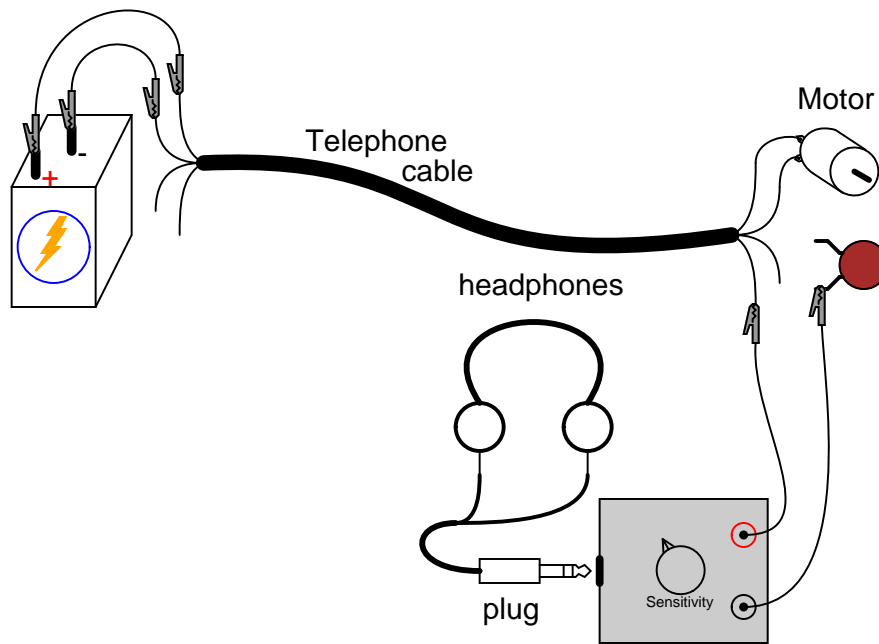

INSTRUCTIONS

Connect the motor to the battery using two of the telephone cable's four conductors. The motor should run, as expected. Now, connect the audio signal detector across the motor terminals, with the $0.047 \mu\text{F}$ capacitor in series, like this:

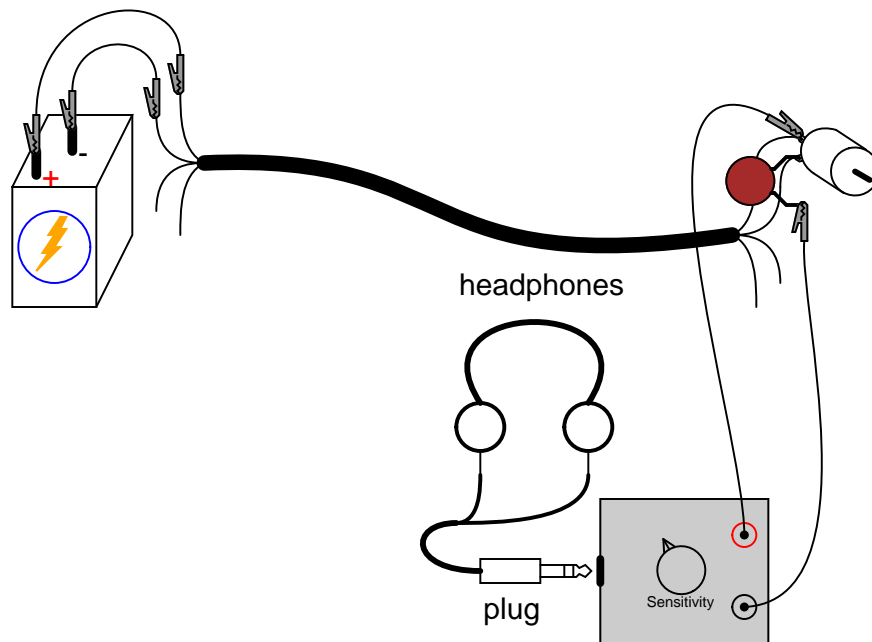

You should be able to hear a "buzz" or "whine" in the headphones, representing the AC "noise" voltage produced by the motor as the brushes make and break contact with the rotating commutator bars. The purpose of the series capacitor is to act as a high-pass filter, so that the detector only receives the AC voltage across the motor's terminals, not any DC voltage. This is precisely how oscilloscopes provide an "AC coupling" feature for measuring the AC content of a signal without any DC bias voltage: a capacitor is connected in series with one test probe.

Ideally, one would expect nothing but pure DC voltage at the motor's terminals, because the motor is connected directly in parallel with the battery. Since the motor's terminals are electrically common with the respective terminals of the battery, and the battery's nature is to maintain a constant DC voltage, nothing but DC voltage should appear at the motor terminals, right? Well, because of resistance internal to the battery and along the conductor lengths, current pulses drawn by the motor produce oscillating voltage "dips" at the motor terminals, causing the AC "noise" heard by the detector:

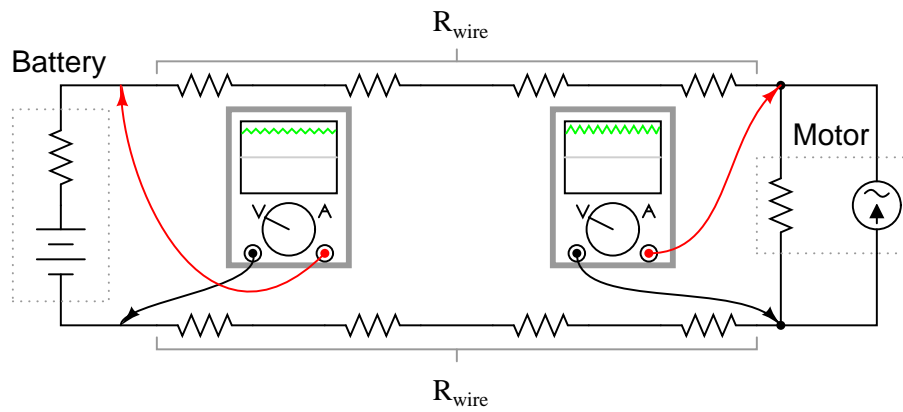

Use the audio detector to measure "noise" voltage directly across the battery. Since the AC noise is produced in this circuit by pulsating voltage drops along stray resistances, the less resistance we measure across, the less noise voltage we should detect:

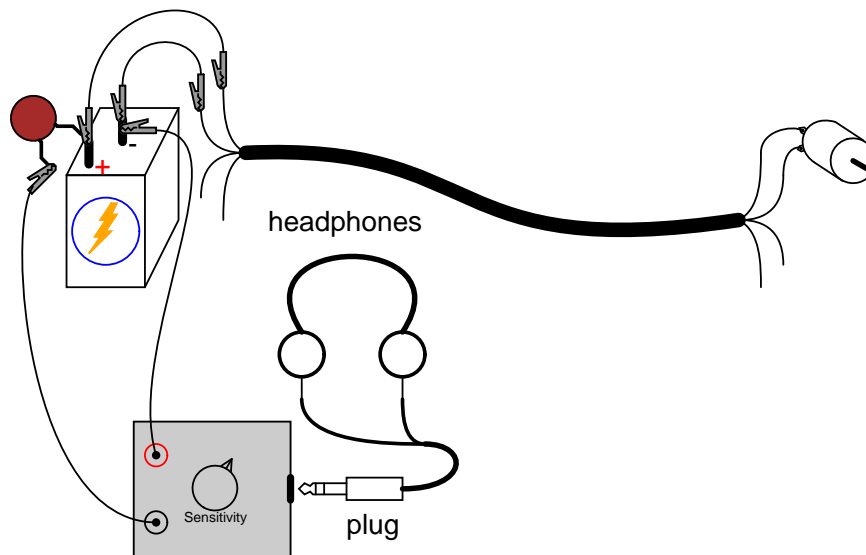

You may also measure noise voltage dropped along either of the telephone cable conductors supplying power to the motor, by connecting the audio detector between both ends of a single cable conductor. The noise detected here originates from current pulses through the resistance of the wire:

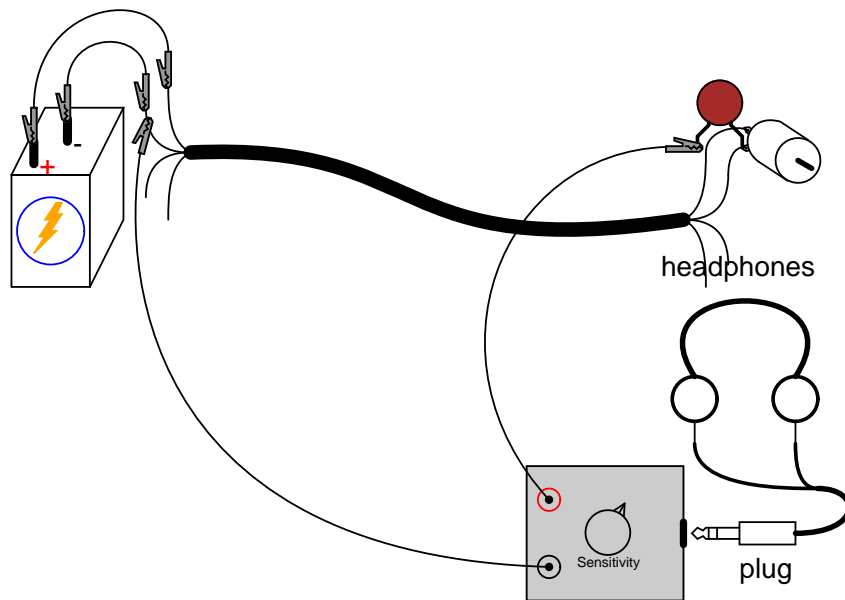

Now that we have established how AC noise is created and distributed in this circuit, let's explore how it is *coupled* to adjacent wires in the cable. Use the audio detector to measure voltage between one of the motor terminals and one of the unused wires in the telephone cable. The $0.047 \mu\text{F}$ capacitor is not needed in this exercise, because there is no DC voltage between these points for the detector to detect anyway:

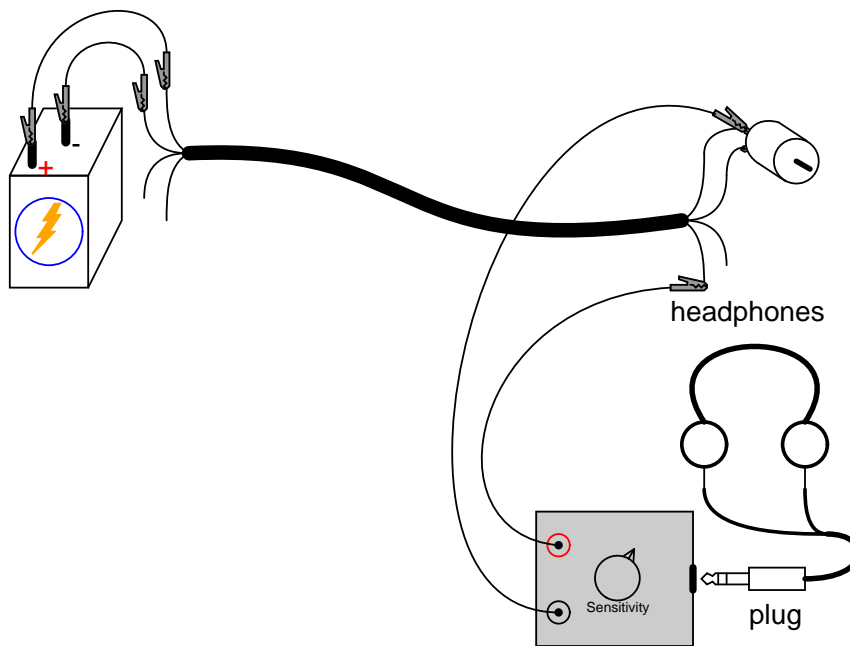

The noise voltage detected here is due to stray capacitance between adjacent cable conductors creating an AC current "path" between the wires. Remember that no current actually goes *through* a capacitance, but the alternate charging and discharging action of a capacitance, whether it be intentional or unintentional, provides *alternating* current a pathway of sorts.

If we were to try and conduct a voltage signal between one of the unused wires and a point common with the motor, that signal would become tainted with noise voltage from the motor. This could be quite detrimental, depending on how much noise was coupled between the two circuits and how sensitive one circuit was to the other's noise. Since the primary coupling phenomenon in this circuit is capacitive in nature, higher-frequency noise voltages are more strongly coupled than lower-frequency noise voltages.

If the additional signal was a DC signal, with no AC expected in it, we could mitigate the problem of coupled noise by "decoupling" the AC noise with a relatively large capacitor connected across the DC signal's conductors. Use the $0.22 \mu\text{F}$ capacitor for this purpose, as shown:

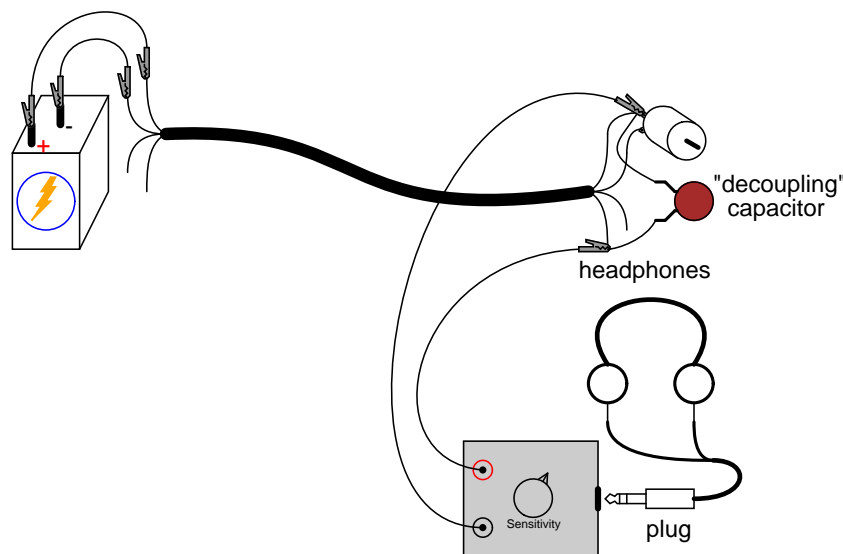

The *decoupling capacitor* acts as a practical short-circuit to any AC noise voltage, while not affecting DC voltage signals between those two points at all. So long as the decoupling capacitor value is significantly larger than the stray "coupling" capacitance between the cable's conductors, the AC noise voltage will be held to a minimum.

Another way of minimizing coupled noise in a cable is to avoid having two circuits share a common conductor. To illustrate, connect the audio detector between the two unused wires and listen for a noise signal:

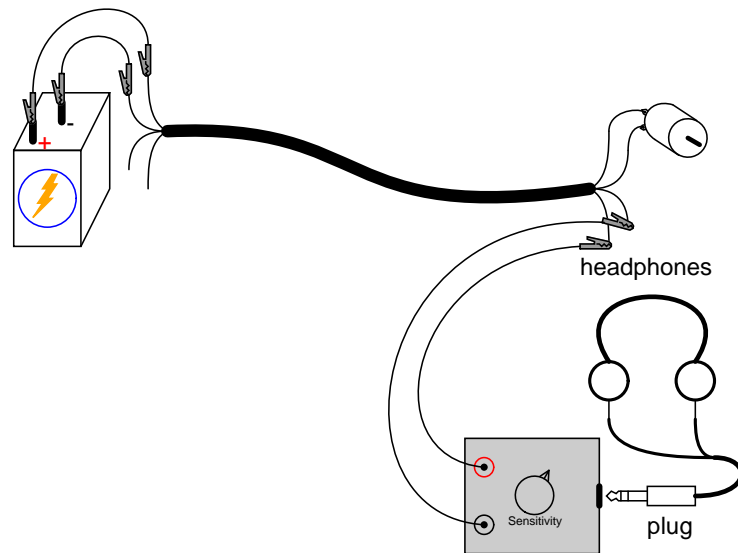

There should be far less noise detected between any two of the unused conductors than between one unused conductor and one used in the motor circuit. The reason for this drastic reduction in noise is that stray capacitance between cable conductors tends to couple the *same* noise voltage to *both* of the unused conductors in approximately equal proportions. Thus, when measuring voltage *between* those two conductors, the detector only "sees" the difference between two approximately identical noise signals.

Chapter 5

DISCRETE SEMICONDUCTOR CIRCUITS

Contents

5.1 Introduction	200
5.2 Commutating diode	201
5.3 Half-wave rectifier	203
5.4 Full-wave center-tap rectifier	211
5.5 Full-wave bridge rectifier	216
5.6 Rectifier/filter circuit	219
5.7 Voltage regulator	225
5.8 Transistor as a switch	228
5.9 Static electricity sensor	233
5.10 Pulsed-light sensor	236
5.11 Voltage follower	239
5.12 Common-emitter amplifier	244
5.13 Multi-stage amplifier	249
5.14 Current mirror	253
5.15 JFET current regulator	259
5.16 Differential amplifier	264
5.17 Simple op-amp	267
5.18 Audio oscillator	272
5.19 Vacuum tube audio amplifier	275
Bibliography	286

5.1 Introduction

A *semiconductor* device is one made of silicon or any number of other specially prepared materials designed to exploit the unique properties of electrons in a crystal lattice, where electrons are not as free to move as in a conductor, but are far more mobile than in an insulator. A *discrete* device is one contained in its own package, not built on a common semiconductor substrate with other components, as is the case with ICs, or *integrated circuits*. Thus, "discrete semiconductor circuits" are circuits built out of individual semiconductor components, connected together on some kind of circuit board or terminal strip. These circuits employ all the components and concepts explored in the previous chapters, so a firm comprehension of DC and AC electricity is essential before embarking on these experiments.

Just for fun, one circuit is included in this section using a *vacuum tube* for amplification instead of a semiconductor transistor. Before the advent of transistors, "vacuum tubes" were the workhorses of the electronics industry: used to make rectifiers, amplifiers, oscillators, and many other circuits. Though now considered obsolete for most purposes, there are still some applications for vacuum tubes, and it can be fun building and operating circuits using these devices.

5.2 Commutating diode

PARTS AND MATERIALS

- 6 volt battery
- Power transformer, 120VAC step-down to 12VAC (Radio Shack catalog # 273-1365, 273-1352, or 273-1511).
- One 1N4001 rectifying diode (Radio Shack catalog # 276-1101)
- One neon lamp (Radio Shack catalog # 272-1102)
- Two toggle switches, SPST ("Single-Pole, Single-Throw")

A power transformer is specified, but any iron-core inductor will suffice, even the home-made inductor or transformer from the AC experiments chapter!

The diode need not be an exact model 1N4001. Any of the "1N400X" series of rectifying diodes are suitable for the task, and they are quite easy to obtain.

I recommend household light switches for their low cost and durability.

CROSS-REFERENCES

Lessons In Electric Circuits, Volume 1, chapter 16: "RC and L/R Time Constants"

Lessons In Electric Circuits, Volume 3, chapter 3: "Diodes and Rectifiers"

LEARNING OBJECTIVES

- Review inductive "kickback"
- Learn how to suppress "kickback" using a diode

SCHEMATIC DIAGRAM

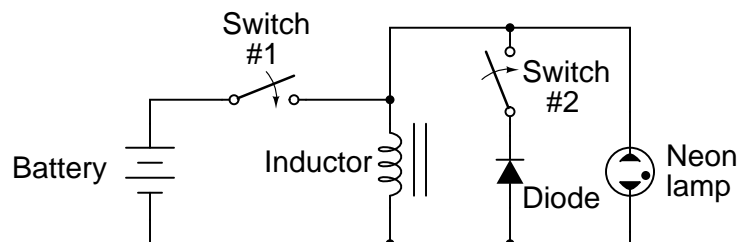

ILLUSTRATION

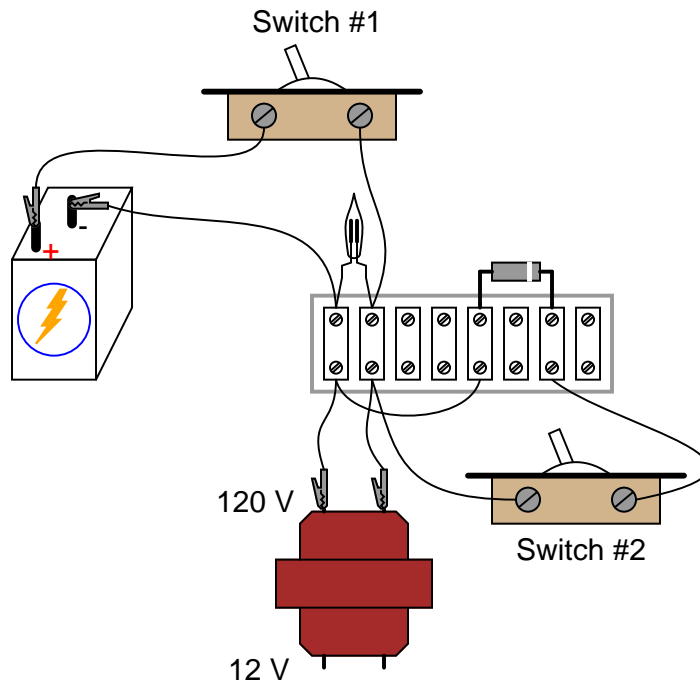

INSTRUCTIONS

When assembling the circuit, be very careful of the diode's orientation. The cathode end of the diode (the end marked with a single band) must face the positive (+) side of the battery. The diode should be reverse-biased and nonconducting with switch #1 in the "on" position. Use the high-voltage (120 V) winding of the transformer for the inductor coil. The primary winding of a step-down transformer has more inductance than the secondary winding, and will give a greater lamp-flashing effect.

Set switch #2 to the "off" position. This disconnects the diode from the circuit so that it has no effect. Quickly close and open (turn "on" and then "off") switch #1. When that switch is opened, the neon bulb will flash from the effect of inductive "kickback." Rapid current decrease caused by the switch's opening causes the inductor to create a large voltage drop as it attempts to keep current at the same magnitude and going in the same direction.

Inductive kickback is detrimental to switch contacts, as it causes excessive arcing whenever they are opened. In this circuit, the neon lamp actually diminishes the effect by providing an alternate current path for the inductor's current when the switch opens, dissipating the inductor's stored energy harmlessly in the form of light and heat. However, there is still a fairly high voltage dropped across the opening contacts of switch #1, causing undue arcing and shortened switch life.

If switch #2 is closed (turned "on"), the diode will now be a part of the circuit. Quickly close and open switch #1 again, noting the difference in circuit behavior. This time, the neon lamp does not flash. Connect a voltmeter across the inductor to verify that the inductor is still receiving full battery voltage with switch #1 closed. If the voltmeter registers only a small voltage with switch #1 "on," the diode is probably connected backward, creating a short-circuit.

5.3 Half-wave rectifier

PARTS AND MATERIALS

- Low-voltage AC power supply (6 volt output)
- 6 volt battery
- One 1N4001 rectifying diode (Radio Shack catalog # 276-1101)
- Small "hobby" motor, permanent-magnet type (Radio Shack catalog # 273-223 or equivalent)
- Audio detector with headphones
- 0.1 μF capacitor (Radio Shack catalog # 272-135 or equivalent)

The diode need not be an exact model 1N4001. Any of the "1N400X" series of rectifying diodes are suitable for the task, and they are quite easy to obtain.

See the AC experiments chapter for detailed instructions on building the "audio detector" listed here. If you haven't built one already, you're missing a simple and valuable tool for experimentation.

A 0.1 μF capacitor is specified for "coupling" the audio detector to the circuit, so that only AC reaches the detector circuit. This capacitor's value is not critical. I've used capacitors ranging from 0.27 μF to 0.015 μF with success. Lower capacitor values attenuate low-frequency signals to a greater degree, resulting in less sound intensity from the headphones, so use a greater-value capacitor value if you experience difficulty hearing the tone(s).

CROSS-REFERENCES

Lessons In Electric Circuits, Volume 3, chapter 3: "Diodes and Rectifiers"

LEARNING OBJECTIVES

- Function of a diode as a rectifier
- Permanent-magnet motor operation on AC versus DC power
- Measuring "ripple" voltage with a voltmeter

SCHEMATIC DIAGRAM

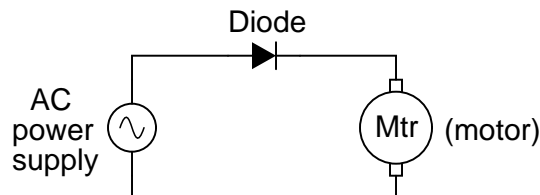

ILLUSTRATION

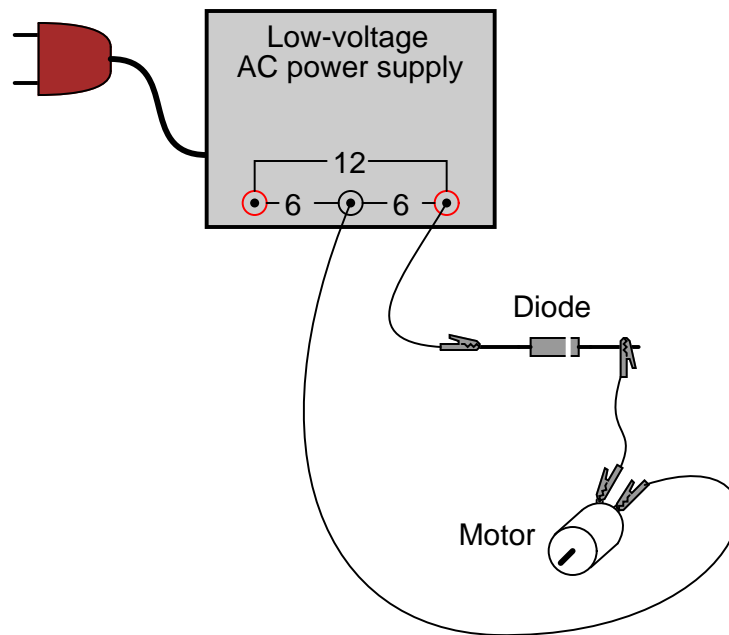

INSTRUCTIONS

Connect the motor to the low-voltage AC power supply through the rectifying diode as shown. The diode only allows current to pass through during one half-cycle of a full positive-and-negative cycle of power supply voltage, eliminating one half-cycle from ever reaching the motor. As a result, the motor only "sees" current in one direction, albeit a *pulsating* current, allowing it to spin in one direction.

Take a jumper wire and short past the diode momentarily, noting the effect on the motor's operation:

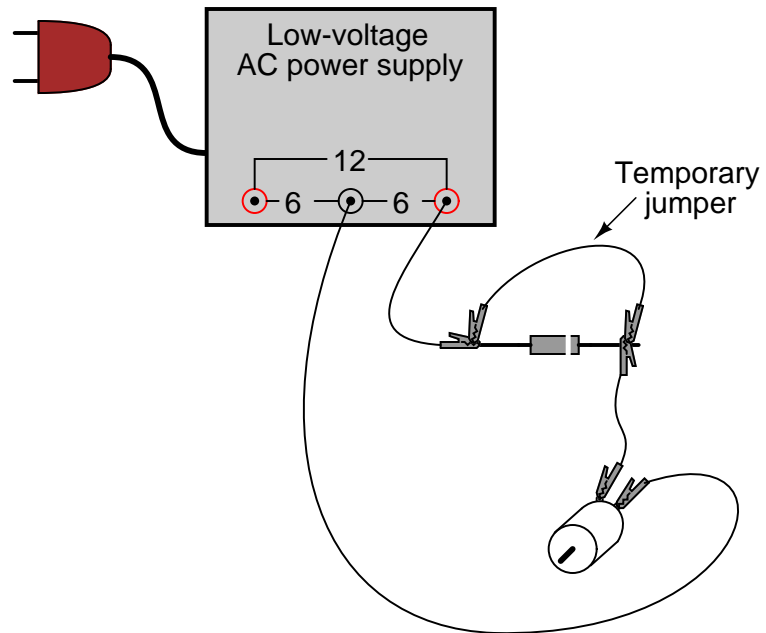

As you can see, permanent-magnet "DC" motors do not function well on alternating current. Remove the temporary jumper wire and reverse the diode's orientation in the circuit. Note the effect on the motor.

Measure DC voltage across the motor like this:

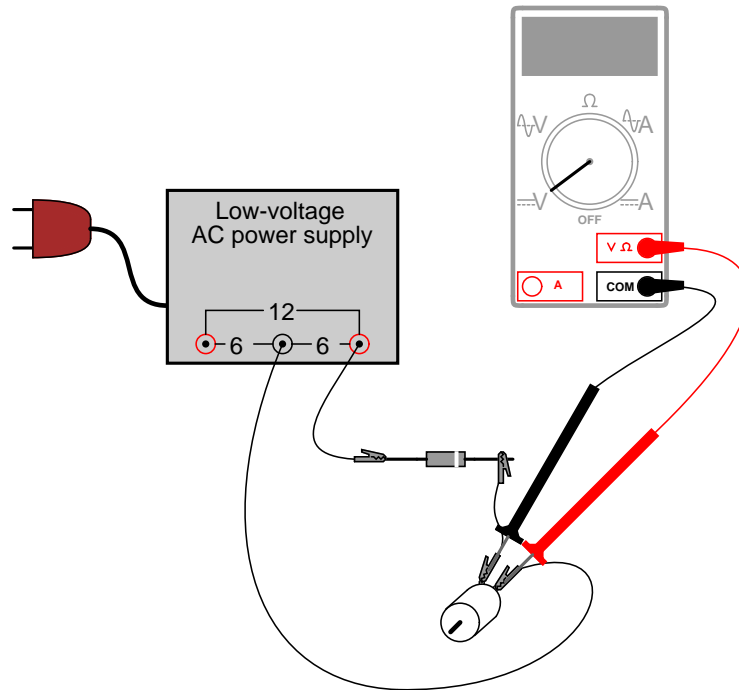

Then, measure AC voltage across the motor as well:

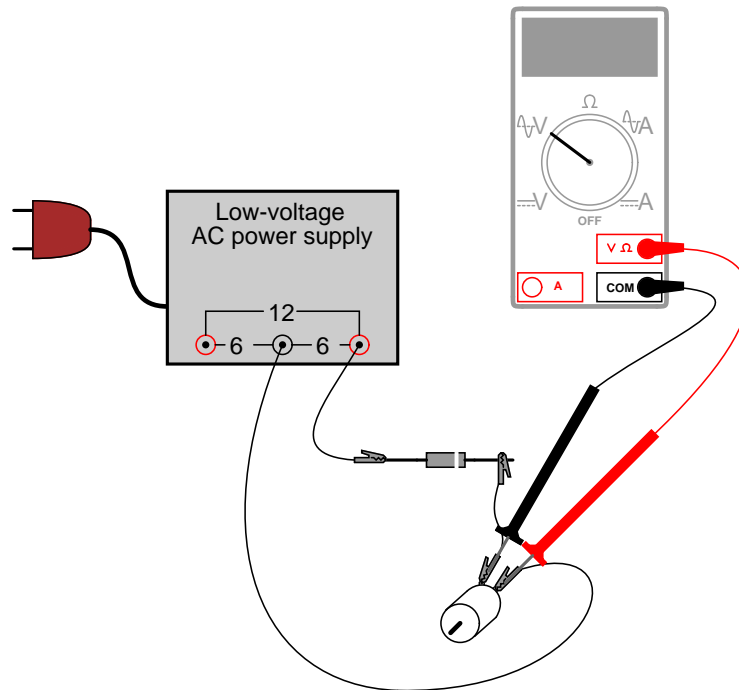

Most digital multimeters do a good job of discriminating AC from DC voltage, and these two measurements show the DC average and AC "ripple" voltages, respectively of the power "seen" by the motor. *Ripple voltage* is the varying portion of the voltage, interpreted as an AC quantity by measurement equipment although the voltage waveform never actually reverses polarity. Ripple may be envisioned as an AC signal superimposed on a steady DC "bias" or "offset" signal. Compare these measurements of DC and AC with voltage measurements taken across the motor while powered by a battery:

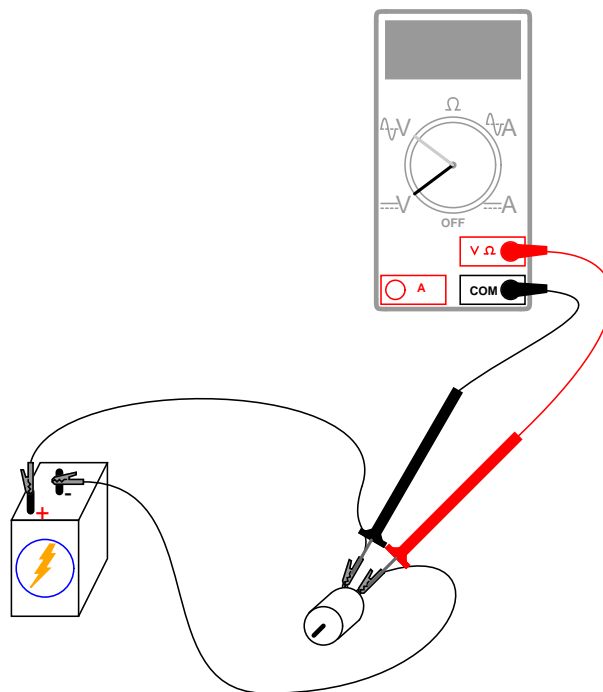

Batteries give very "pure" DC power, and as a result there should be very little AC voltage measured across the motor in this circuit. Whatever AC voltage *is* measured across the motor is due to the motor's pulsating current draw as the brushes make and break contact with the rotating commutator bars. This pulsating current causes pulsating voltages to be dropped across any stray resistances in the circuit, resulting in pulsating voltage "dips" at the motor terminals.

A qualitative assessment of ripple voltage may be obtained by using the sensitive audio detector described in the AC experiments chapter (the same device described as a "sensitive voltage detector" in the DC experiments chapter). Turn the detector's sensitivity down for low volume, and connect it across the motor terminals through a small ($0.1 \mu\text{F}$) capacitor, like this:

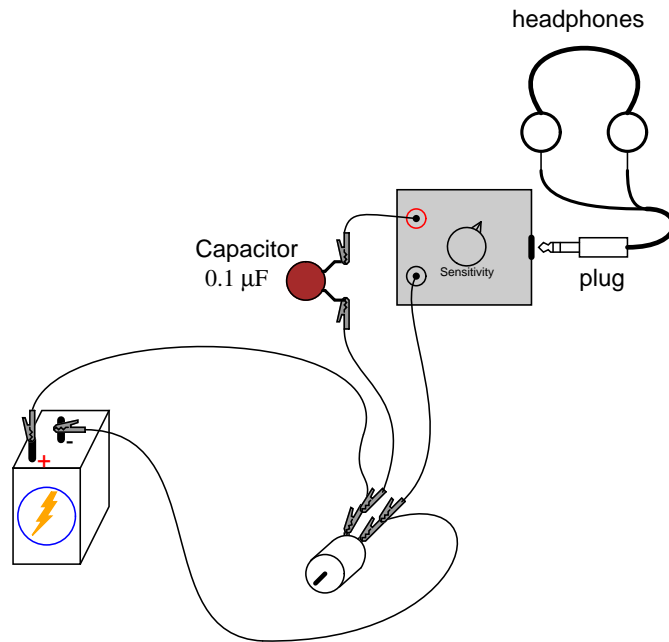

The capacitor acts as a high-pass filter, blocking DC voltage from reaching the detector and allowing easier "listening" of the remaining AC voltage. This is the exact same technique used in oscilloscope circuitry for "AC coupling," where DC signals are blocked from viewing by a series-connected capacitor. With a battery powering the motor, the ripple should sound like a high-pitched "buzz" or "whine." Try replacing the battery with the AC power supply and rectifying diode, "listening" with the detector to the low-pitched "buzz" of the half-wave rectified power:

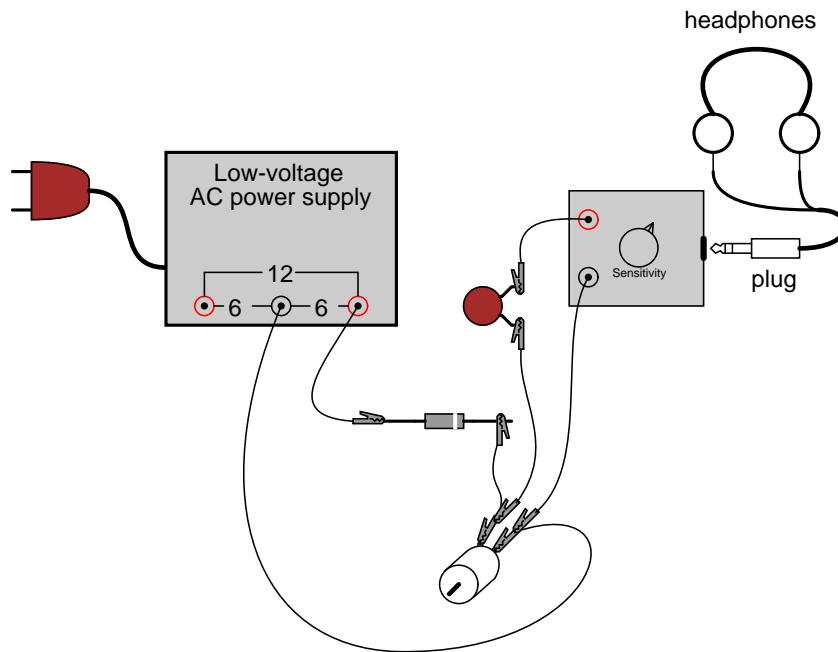
**COMPUTER SIMULATION**

Schematic with SPICE node numbers:

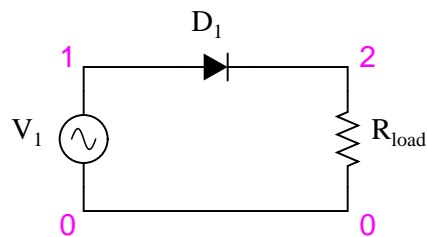

Netlist (make a text file containing the following text, verbatim):

```
Halfwave rectifier
v1 1 0 sin(0 8.485 60 0 0)
rload 2 0 10k
d1 1 2 mod1
.model mod1 d
.tran .5m 25m
.plot tran v(1,0) v(2,0)
.end
```

This simulation plots the input voltage as a sine wave and the output voltage as a series of "humps" corresponding to the positive half-cycles of the AC source voltage. The dynamics of a DC motor are far too complex to be simulated using SPICE, unfortunately.

AC source voltage is specified as 8.485 instead of 6 volts because SPICE understands AC voltage in terms of *peak* value only. A 6 volt RMS sine-wave voltage is actually 8.485 volts peak. In simulations where the distinction between RMS and peak value isn't relevant, I will not bother with an RMS-to-peak conversion like this. To be truthful, the distinction is not terribly important in this simulation, but I discuss it here for your edification.

5.4 Full-wave center-tap rectifier

PARTS AND MATERIALS

- Low-voltage AC power supply (6 volt output)
- Two 1N4001 rectifying diodes (Radio Shack catalog # 276-1101)
- Small "hobby" motor, permanent-magnet type (Radio Shack catalog # 273-223 or equivalent)
- Audio detector with headphones
- 0.1 μF capacitor
- One toggle switch, SPST ("Single-Pole, Single-Throw")

It is essential for this experiment that the low-voltage AC power supply be equipped with a center tap. A transformer with a non-tapped secondary winding simply will not work for this circuit.

The diodes need not be exact model 1N4001 units. Any of the "1N400X" series of rectifying diodes are suitable for the task, and they are quite easy to obtain.

CROSS-REFERENCES

Lessons In Electric Circuits, Volume 3, chapter 3: "Diodes and Rectifiers"

LEARNING OBJECTIVES

- Design of a center-tap rectifier circuit
- Measuring "ripple" voltage with a voltmeter

SCHEMATIC DIAGRAM

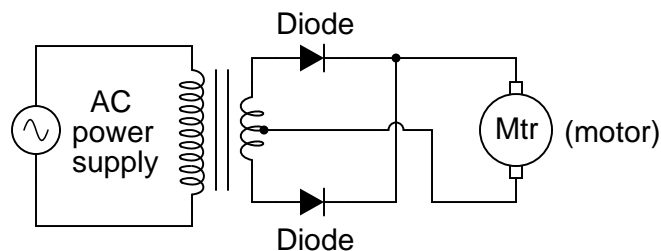

ILLUSTRATION

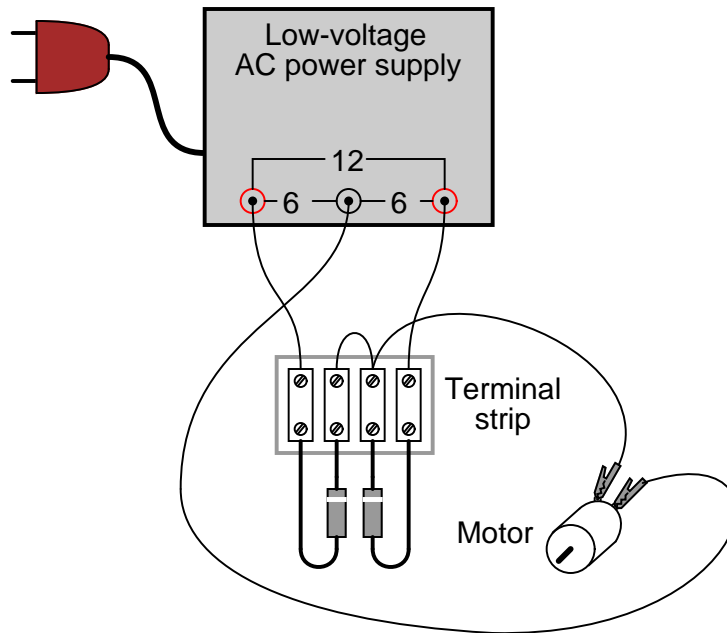

INSTRUCTIONS

This rectifier circuit is called *full-wave* because it makes use of the entire waveform, both positive and negative half-cycles, of the AC source voltage in powering the DC load. As a result, there is less "ripple" voltage seen at the load. The RMS (Root-Mean-Square) value of the rectifier's output is also greater for this circuit than for the half-wave rectifier.

Use a voltmeter to measure both the DC and AC voltage delivered to the motor. You should notice the advantages of the full-wave rectifier immediately by the greater DC and lower AC indications as compared to the last experiment.

An experimental advantage of this circuit is the ease of which it may be "de-converted" to a half-wave rectifier: simply disconnect the short jumper wire connecting the two diodes' cathode ends together on the terminal strip. Better yet, for quick comparison between half and full-wave rectification, you may add a switch in the circuit to open and close this connection at will:

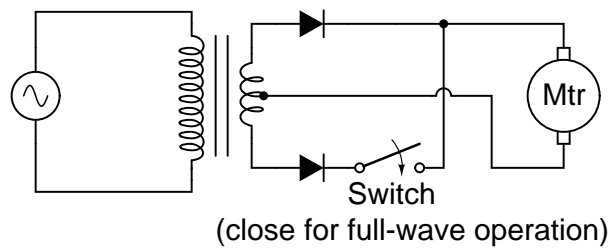

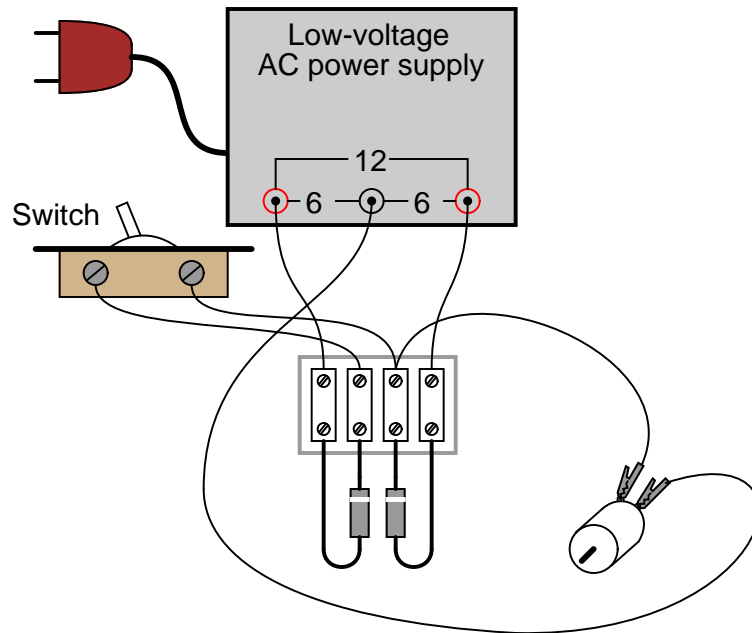

With the ability to quickly switch between half- and full-wave rectification, you may easily perform qualitative comparisons between the two different operating modes. Use the audio signal detector to "listen" to the ripple voltage present between the motor terminals for half-wave and full-wave rectification modes, noting both the intensity and the quality of the tone. Remember to use a coupling capacitor in series with the detector so that it only receives the AC "ripple" voltage and not DC voltage:

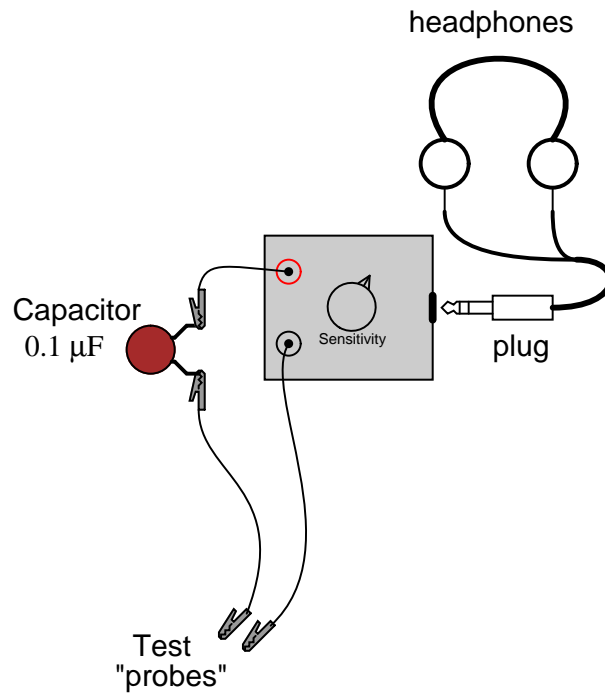
**COMPUTER SIMULATION**

Schematic with SPICE node numbers:

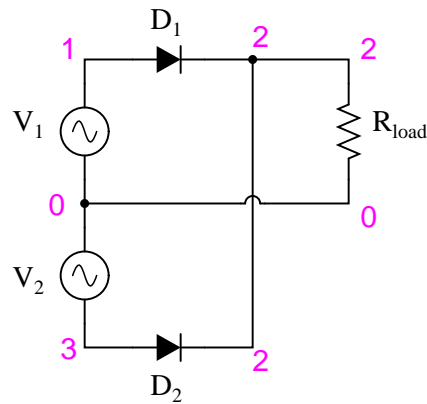

Netlist (make a text file containing the following text, verbatim):

```
Fullwave center-tap rectifier
v1 1 0 sin(0 8.485 60 0 0)
v2 0 3 sin(0 8.485 60 0 0)
rload 2 0 10k
d1 1 2 mod1
```

```
d2 3 2 mod1
.model mod1 d
.tran .5m 25m
.plot tran v(1,0) v(2,0)
.end
```

5.5 Full-wave bridge rectifier

PARTS AND MATERIALS

- Low-voltage AC power supply (6 volt output)
- Four 1N4001 rectifying diodes (Radio Shack catalog # 276-1101)
- Small "hobby" motor, permanent-magnet type (Radio Shack catalog # 273-223 or equivalent)

CROSS-REFERENCES

Lessons In Electric Circuits, Volume 3, chapter 3: "Diodes and Rectifiers"

LEARNING OBJECTIVES

- Design of a bridge rectifier circuit
- Advantages and disadvantages of the bridge rectifier circuit, compared to the center-tap circuit

SCHEMATIC DIAGRAM

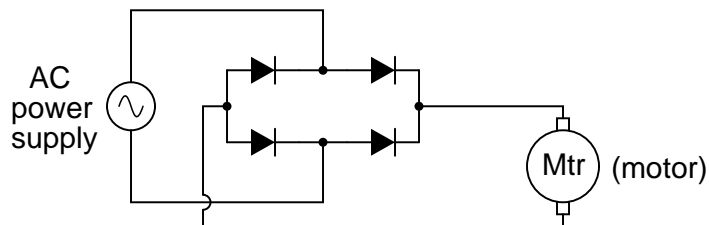

ILLUSTRATION

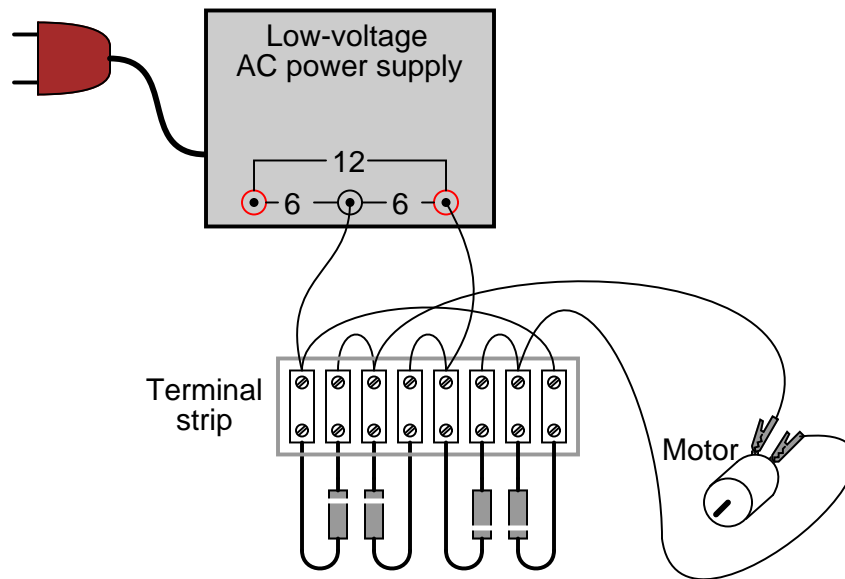

INSTRUCTIONS

This circuit provides full-wave rectification without the necessity of a center-tapped transformer. In applications where a center-tapped, or *split-phase*, source is unavailable, this is the only practical method of full-wave rectification.

In addition to requiring more diodes than the center-tap circuit, the full-wave bridge suffers a slight performance disadvantage as well: the additional voltage drop caused by current having to go through *two* diodes in each half-cycle rather than through only one. With a low-voltage source such as the one you're using (6 volts RMS), this disadvantage is easily measured. Compare the DC voltage reading across the motor terminals with the reading obtained from the last experiment, given the same AC power supply and the same motor.

COMPUTER SIMULATION

Schematic with SPICE node numbers:

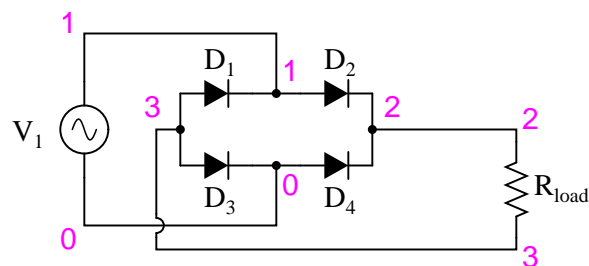

Netlist (make a text file containing the following text, verbatim):

```
Fullwave bridge rectifier
v1 1 0 sin(0 8.485 60 0 0)
```

```
rload 2 3 10k
d1 3 1 mod1
d2 1 2 mod1
d3 3 0 mod1
d4 0 2 mod1
.model mod1 d
.tran .5m 25m
.plot tran v(1,0) v(2,3)
.end
```

5.6 Rectifier/filter circuit

PARTS AND MATERIALS

- Low-voltage AC power supply
- Bridge rectifier pack (Radio Shack catalog # 276-1185 or equivalent)
- Electrolytic capacitor, 1000 μF , at least 25 WVDC (Radio Shack catalog # 272-1047 or equivalent)
- Four "banana" jack style binding posts, or other terminal hardware, for connection to potentiometer circuit (Radio Shack catalog # 274-662 or equivalent)
- Metal box
- 12-volt light bulb, 25 watt
- Lamp socket

A bridge rectifier "pack" is highly recommended over constructing a bridge rectifier circuit from individual diodes, because such "packs" are made to bolt onto a metal heat sink. A metal box is recommended over a plastic box for its ability to function as a heat sink for the rectifier.

A larger capacitor value is fine to use in this experiment, so long as its working voltage is high enough. To be safe, choose a capacitor with a working voltage rating at least twice the RMS AC voltage output of the low-voltage AC power supply.

High-wattage 12-volt lamps may be purchased from recreational vehicle (RV) and boating supply stores. Common sizes are 25 watt and 50 watt. This lamp will be used as a "heavy" load for the power supply.

CROSS-REFERENCES

Lessons In Electric Circuits, Volume 2, chapter 8: "Filters"

LEARNING OBJECTIVES

- Capacitive filter function in an AC/DC power supply
- Importance of heat sinks for power semiconductors

SCHEMATIC DIAGRAM

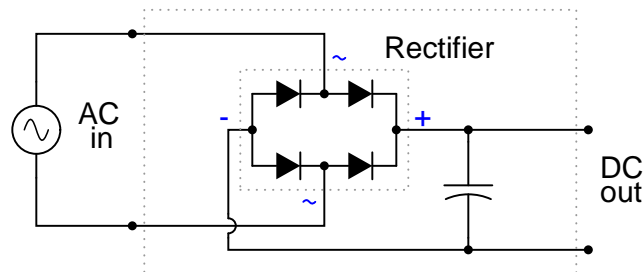

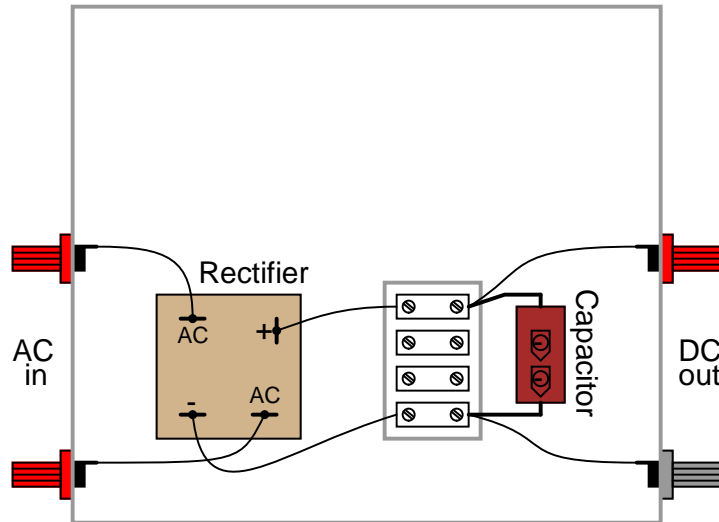
ILLUSTRATION**INSTRUCTIONS**

This experiment involves constructing a rectifier and filter circuit for attachment to the low-voltage AC power supply constructed earlier. With this device, you will have a source of low-voltage, DC power suitable as a replacement for a battery in battery-powered experiments. If you would like to make this device its own, self-contained 120VAC/DC power supply, you may add all the componentry of the low-voltage AC supply to the "AC in" side of this circuit: a transformer, power cord, and plug. Even if you don't choose to do this, I recommend using a metal box larger than necessary to provide room for additional voltage regulation circuitry you might choose to add to this project later.

The bridge rectifier unit should be rated for a current at least as high as the transformer's secondary winding is rated for, and for a voltage at least twice as high as the RMS voltage of the transformer's output (this allows for peak voltage, plus an additional safety margin). The Radio Shack rectifier specified in the parts list is rated for 25 amps and 50 volts, more than enough for the output of the low-voltage AC power supply specified in the AC experiments chapter.

Rectifier units of this size are often equipped with "quick-disconnect" terminals. Complementary "quick-disconnect" lugs are sold that crimp onto the bare ends of wire. This is the preferred method of terminal connection. You may solder wires directly to the lugs of the rectifier, but I recommend against direct soldering to any semiconductor component for two reasons: possible heat damage during soldering, and difficulty of replacing the component in the event of failure.

Semiconductor devices are more prone to failure than most of the components covered in these experiments thus far, and so if you have any intent of making a circuit permanent, you should build it to be maintained. "Maintainable construction" involves, among other things, making all delicate components replaceable. It also means making "test points" accessible to meter probes throughout the circuit, so that troubleshooting may be executed with a mini-

num of inconvenience. Terminal strips inherently provide test points for taking voltage measurements, and they also allow for easy disconnection of wires without sacrificing connection durability.

Bolt the rectifier unit to the inside of the metal box. The box's surface area will act as a radiator, keeping the rectifier unit cool as it passes high currents. Any metal radiator surface designed to lower the operating temperature of an electronic component is called a *heat sink*. Semiconductor devices in general are prone to damage from overheating, so providing a path for heat transfer from the device(s) to the ambient air is very important when the circuit in question may handle large amounts of power.

A capacitor is included in the circuit to act as a *filter* to reduce ripple voltage. Make sure that you connect the capacitor properly across the DC output terminals of the rectifier, so that the polarities match. Being an electrolytic capacitor, it is sensitive to damage by polarity reversal. In this circuit especially, where the internal resistance of the transformer and rectifier are low and the short-circuit current consequently is high, the potential for damage is great. **Warning:** a failed capacitor in this circuit will likely explode with alarming force!

After the rectifier/filter circuit is built, connect it to the low-voltage AC power supply like this:

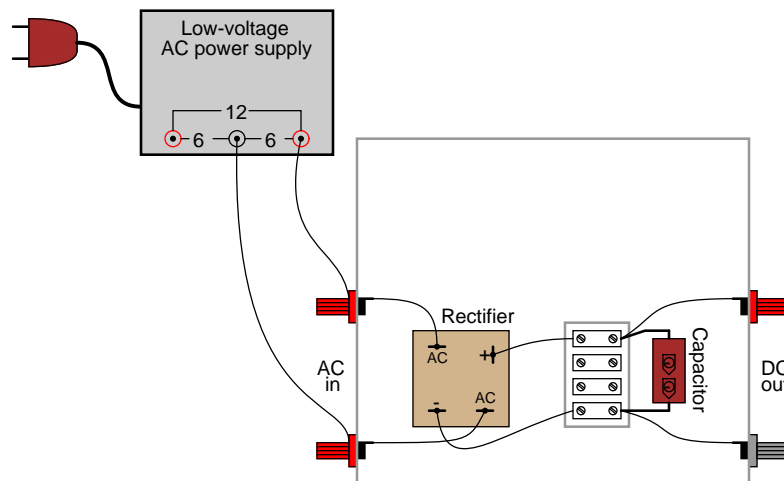

Measure the AC voltage output by the low-voltage power supply. Your meter should indicate approximately 6 volts if the circuit is connected as shown. This voltage measurement is the RMS voltage of the AC power supply.

Now, switch your multimeter to the DC voltage function and measure the DC voltage output by the rectifier/filter circuit. It should read substantially higher than the RMS voltage of the AC input measured before. The filtering action of the capacitor provides a DC output voltage equal to the *peak* AC voltage, hence the greater voltage indication:

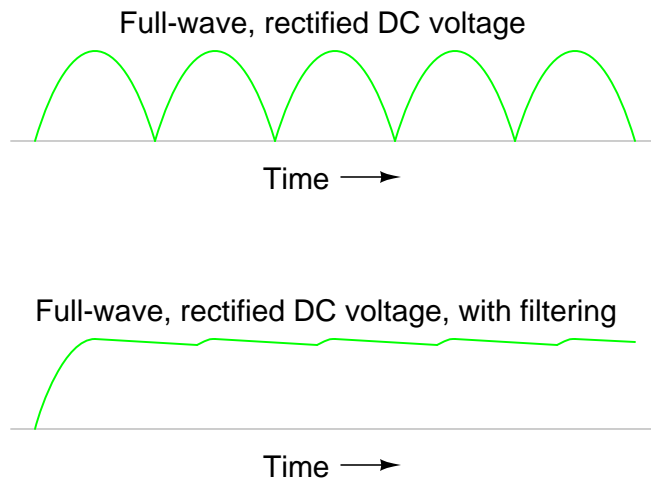

Measure the AC ripple voltage magnitude with a digital voltmeter set to AC volts (or AC millivolts). You should notice a much smaller ripple voltage in this circuit than what was measured in any of the unfiltered rectifier circuits previously built. Feel free to use your audio detector to "listen" to the AC ripple voltage output by the rectifier/filter unit. As usual, connect a small "coupling" capacitor in series with the detector so that it does not respond to the DC voltage, but only the AC ripple. Very little sound should be heard.

After taking unloaded AC ripple voltage measurements, connect the 25 watt light bulb to the output of the rectifier/filter circuit like this:

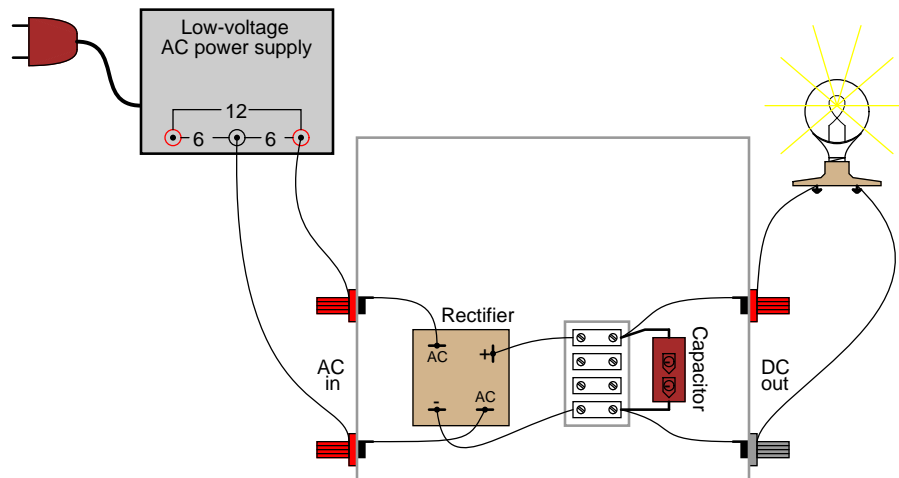

Re-measure the ripple voltage present between the rectifier/filter unit's "DC out" terminals. With a heavy load, the filter capacitor becomes discharged between rectified voltage peaks, resulting in greater ripple than before:

Full-wave, filtered DC voltage under heavy load

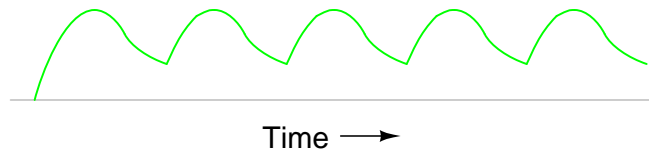

If less ripple is desired under heavy-load conditions, a larger capacitor may be used, or a more complex filter circuit may be built using two capacitors and an inductor:

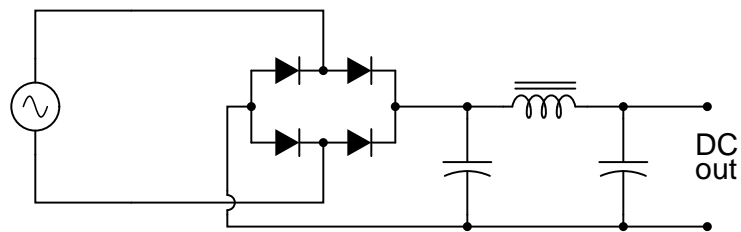

If you choose to build such a filter circuit, be sure to use an iron-core inductor for maximum inductance, and one with thick enough wire to safely handle the full rated current of power supply. Inductors used for the purpose of filtering are sometimes referred to as *chokes*, because they "choke" AC ripple voltage from getting to the load. If a suitable choke cannot be obtained, the secondary winding of a step-down power transformer like the type used to step 120 volts AC down to 12 or 6 volts AC in the low-voltage power supply may be used. Leave the primary (120 volt) winding open:

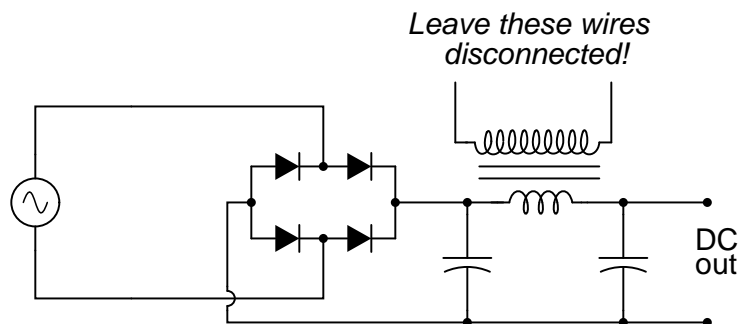

COMPUTER SIMULATION

Schematic with SPICE node numbers:

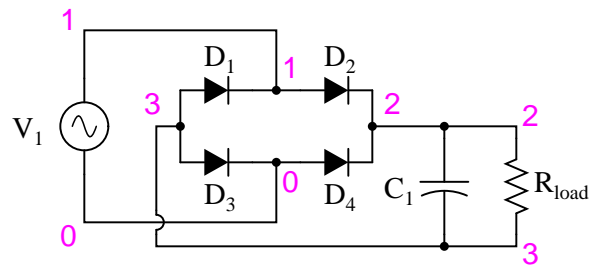

Netlist (make a text file containing the following text, verbatim):

```
Fullwave bridge rectifier
v1 1 0 sin(0 8.485 60 0 0)
rload 2 3 10k
c1 2 3 1000u ic=0
d1 3 1 mod1
d2 1 2 mod1
d3 3 0 mod1
d4 0 2 mod1
.model mod1 d
.tran .5m 25m
.plot tran v(1,0) v(2,3)
.end
```

You may decrease the value of R_{load} in the simulation from 10 k Ω to some lower value to explore the effects of loading on ripple voltage. As it is with a 10 k Ω load resistor, the ripple is undetectable on the waveform plotted by SPICE.

5.7 Voltage regulator

PARTS AND MATERIALS

- Four 6 volt batteries
- Zener diode, 12 volt – type 1N4742 (Radio Shack catalog # 276-563 or equivalent)
- One 10 k Ω resistor

Any low-voltage zener diode is appropriate for this experiment. The 1N4742 model listed here (zener voltage = 12 volts) is but one suggestion. Whatever diode model you choose, I highly recommend one with a zener voltage rating *greater* than the voltage of a single battery, for maximum learning experience. It is important that you see how a zener diode functions when exposed to a voltage *less than* its breakdown rating.

CROSS-REFERENCES

Lessons In Electric Circuits, Volume 3, chapter 3: "Diodes and Rectifiers"

LEARNING OBJECTIVES

- Zener diode function

SCHEMATIC DIAGRAM

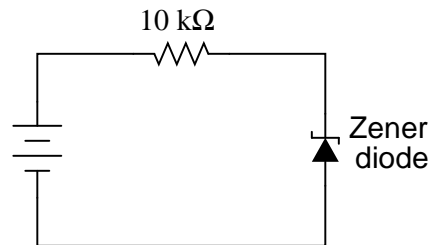

ILLUSTRATION

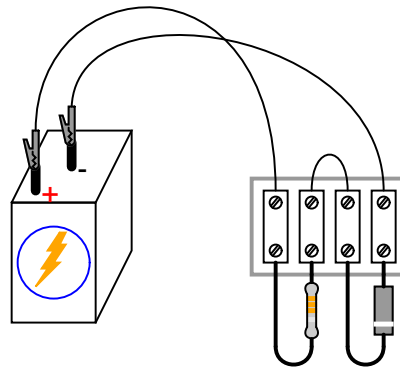

INSTRUCTIONS

Build this simple circuit, being sure to connect the diode in "reverse-bias" fashion (cathode positive and anode negative), and measure the voltage across the diode with one battery as a power source. Record this voltage drop for future reference. Also, measure and record the voltage drop across the $10\text{ k}\Omega$ resistor.

Modify the circuit by connecting two 6-volt batteries in series, for 12 volts total power source voltage. Re-measure the diode's voltage drop, as well as the resistor's voltage drop, with a voltmeter:

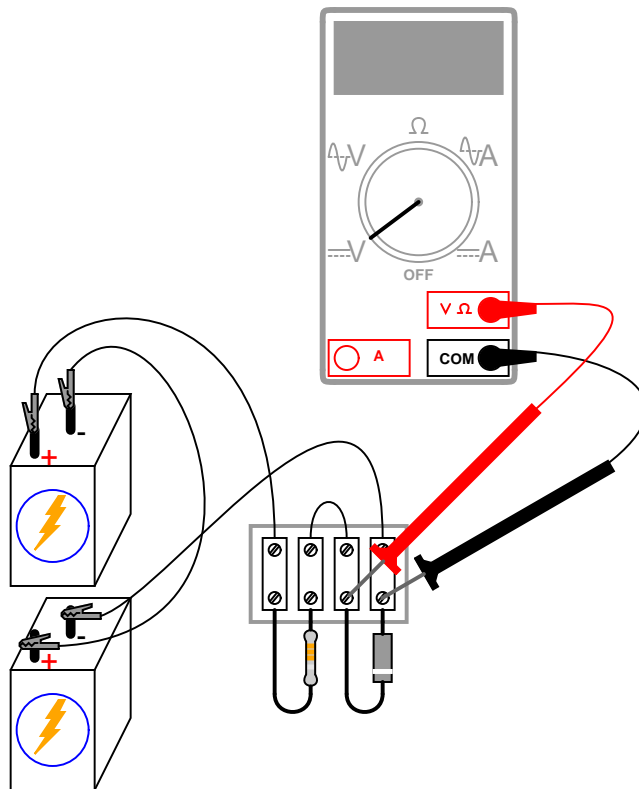

Connect three, then four 6-volt batteries together in series, forming an 18 volt and 24 volt power source, respectively. Measure and record the diode's and resistor's voltage drops for each new power supply voltage. What do you notice about the diode's voltage drop for these four different source voltages? Do you see how the diode voltage never exceeds a level of 12 volts? What do you notice about the resistor's voltage drop for these four different source voltage levels?

Zener diodes are frequently used as voltage *regulating* devices, because they act to clamp the voltage drop across themselves at a predetermined level. Whatever excess voltage is supplied by the power source becomes dropped across the series resistor. However, it is important to note that a zener diode cannot *make up* for a deficiency in source voltage. For instance, this 12-volt zener diode does not drop 12 volts when the power source is only 6 volts strong. It is helpful to think of a zener diode as a voltage *limiter*: establishing a maximum voltage drop,

but not a minimum voltage drop.

COMPUTER SIMULATION

Schematic with SPICE node numbers:

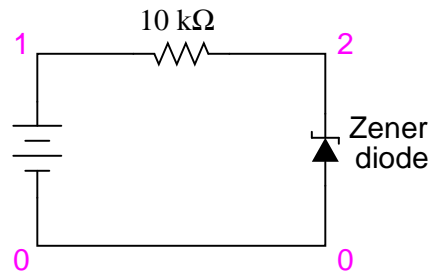

Netlist (make a text file containing the following text, verbatim):

```
Zener diode
v1 1 0
r1 1 2 10k
d1 0 2 mod1
.model mod1 d bv=12
.dc v1 18 18 1
.print dc v(2,0)
.end
```

A zener diode may be simulated in SPICE with a normal diode, the reverse breakdown parameter (bv=12) set to the desired zener breakdown voltage.

5.8 Transistor as a switch

PARTS AND MATERIALS

- Two 6-volt batteries
- One NPN transistor – models 2N2222 or 2N3403 recommended (Radio Shack catalog # 276-1617 is a package of fifteen NPN transistors ideal for this and other experiments)
- One 100 k Ω resistor
- One 560 Ω resistor
- One light-emitting diode (Radio Shack catalog # 276-026 or equivalent)

Resistor values are not critical for this experiment. Neither is the particular light emitting diode (LED) selected.

CROSS-REFERENCES

Lessons In Electric Circuits, Volume 3, chapter 4: "Bipolar Junction Transistors"

LEARNING OBJECTIVES

- Current amplification of a bipolar junction transistor

SCHEMATIC DIAGRAM

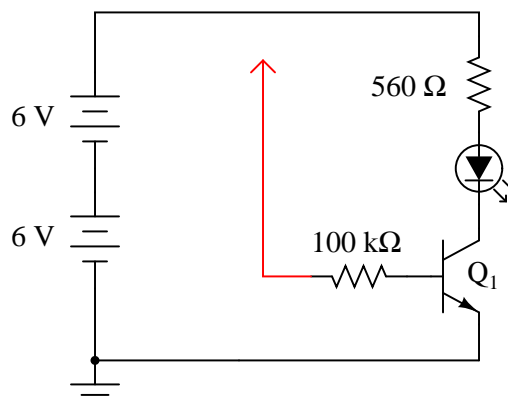

ILLUSTRATION

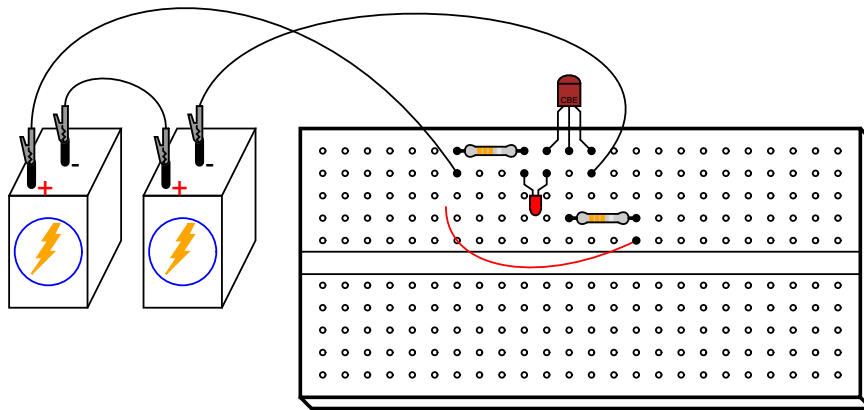

INSTRUCTIONS

The red wire shown in the diagram (the one terminating in an arrowhead, connected to one end of the $100\text{ k}\Omega$ resistor) is intended to remain loose, so that you may touch it momentarily to other points in the circuit.

If you touch the end of the loose wire to any point in the circuit more positive than it, such as the positive side of the DC power source, the LED should light up. It takes 20 mA to fully illuminate a standard LED, so this behavior should strike you as interesting, because the $100\text{ k}\Omega$ resistor to which the loose wire is attached restricts current through it to a far lesser value than 20 mA . At most, a total voltage of 12 volts across a $100\text{ k}\Omega$ resistance yields a current of only 0.12 mA , or $120\text{ }\mu\text{A}$! The connection made by your touching the wire to a positive point in the circuit conducts far less current than 1 mA , yet through the amplifying action of the transistor, is able to *control* a much greater current through the LED.

Try using an ammeter to connect the loose wire to the positive side of the power source, like this:

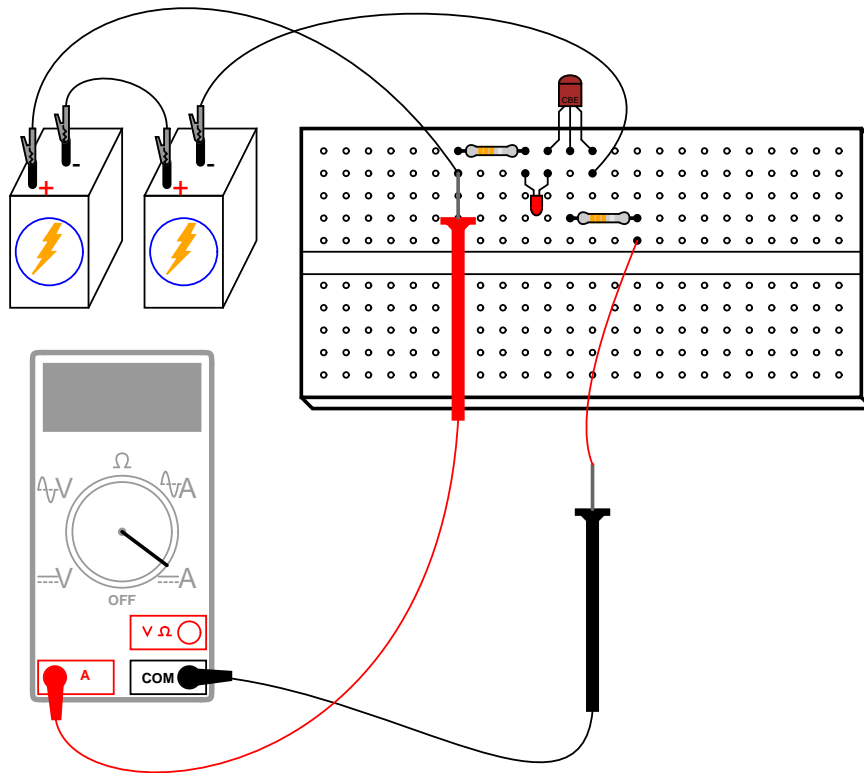

You may have to select the most sensitive current range on the meter to measure this small flow. After measuring this *controlling* current, try measuring the LED's current (the *controlled* current) and compare magnitudes. Don't be surprised if you find a ratio in excess of 200 (the controlled current 200 times as great as the controlling current)!

As you can see, the transistor is acting as a kind of electrically-controlled switch, switching current on and off to the LED at the command of a much smaller current signal conducted through its base terminal.

To further illustrate just how miniscule the controlling current is, remove the loose wire from the circuit and try "bridging" the unconnected end of the 100 kΩ resistor to the power source's positive pole with two fingers of one hand. You may need to wet the ends of those fingers to maximize conductivity:

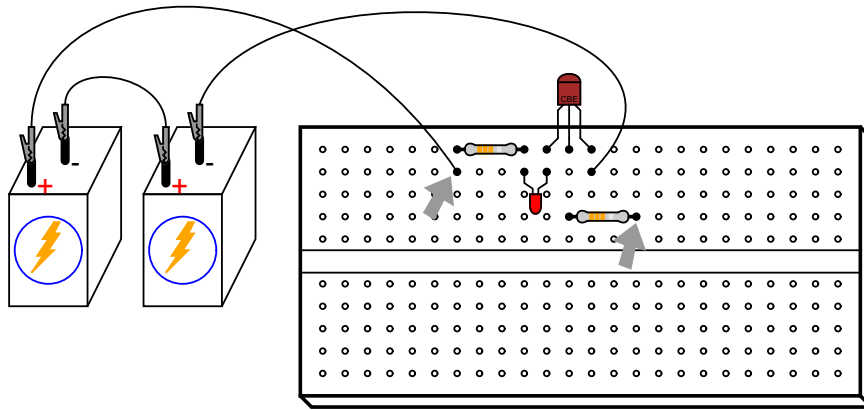

Bridge the two points identified by arrows with two fingers of one hand, to conduct a small current to the transistor's base.

Try varying the contact pressure of your fingers with these two points in the circuit to vary the amount of resistance in the controlling current's path. Can you vary the brightness of the LED by doing so? What does this indicate about the transistor's ability to act as more than just a switch; i.e. as a *variable*

COMPUTER SIMULATION

Schematic with SPICE node numbers:

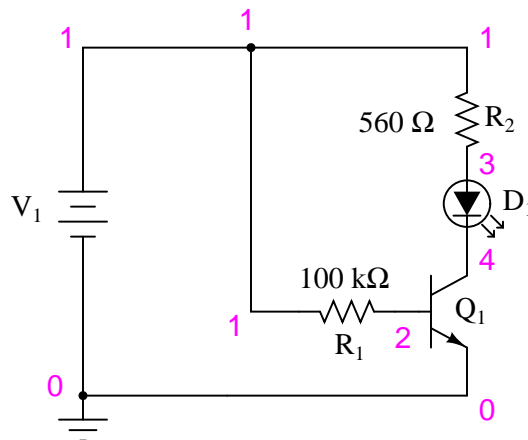

Netlist (make a text file containing the following text, verbatim):

```
Transistor as a switch
v1 1 0
r1 1 2 100k
r2 1 3 560
d1 3 4 mod2
```

```
q1 4 2 0 mod1
.model mod1 npn bf=200
.model mod2 d is=1e-28
.dc v1 12 12 1
.print dc v(2,0) v(4,0) v(1,2) v(1,3) v(3,4)
.end
```

In this simulation, the voltage drop across the $560\ \Omega$ resistor $v(1,3)$ turns out to be 10.26 volts, indicating a LED current of 18.32 mA by Ohm's Law ($I=E/R$). R_1 's voltage drop (voltage between nodes 1 and 2) ends up being 11.15 volts, which across $100\ \text{k}\Omega$ gives a current of only $111.5\ \mu\text{A}$. Obviously, a very small current is exerting control over a much larger current in this circuit.

In case you were wondering, the $is=1e-28$ parameter in the diode's `.model` line is there to make the diode act more like an LED with a higher forward voltage drop.

5.9 Static electricity sensor

PARTS AND MATERIALS

- One N-channel junction field-effect transistor, models 2N3819 or J309 recommended (Radio Shack catalog # 276-2035 is the model 2N3819)
- One 6 volt battery
- One 100 k Ω resistor
- One light-emitting diode (Radio Shack catalog # 276-026 or equivalent)
- Plastic comb

The particular junction field-effect transistor, or JFET, model used in this experiment is not critical. P-channel JFETs are also okay to use, but are not as popular as N-channel transistors.

Beware that not all transistors share the same terminal designations, or *pinouts*, even if they share the same physical appearance. This will dictate how you connect the transistors together and to other components, so be sure to check the manufacturer's specifications (component datasheet), easily obtained from the manufacturer's website. Beware that it is possible for the transistor's package and even the manufacturer's datasheet to show incorrect terminal identification diagrams! Double-checking pin identities with your multimeter's "diode check" function is highly recommended. For details on how to identify junction field-effect transistor terminals using a multimeter, consult chapter 5 of the Semiconductor volume (volume III) of this book series.

CROSS-REFERENCES

Lessons In Electric Circuits, Volume 3, chapter 5: "Junction Field-Effect Transistors"

LEARNING OBJECTIVES

- How the JFET is used as an on/off switch
- How JFET current gain differs from a bipolar transistor

SCHEMATIC DIAGRAM

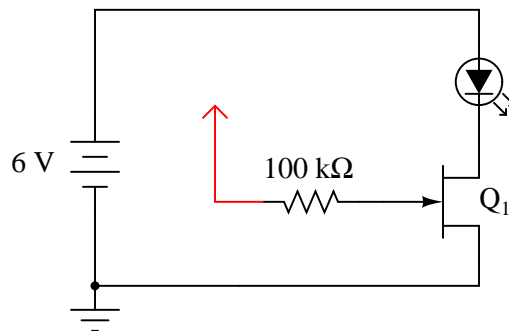

ILLUSTRATION

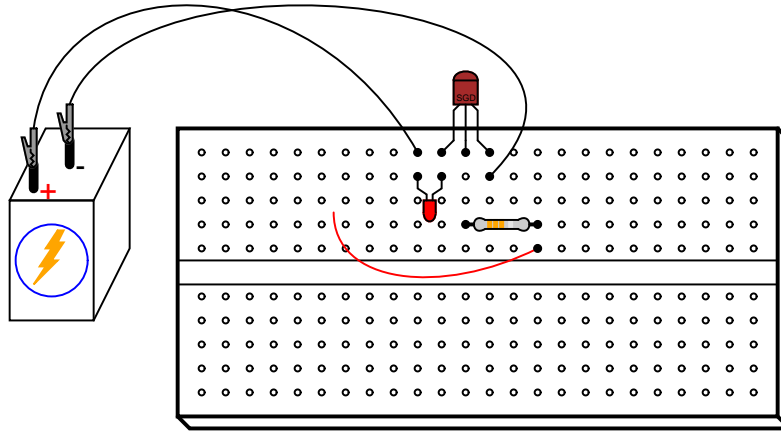

INSTRUCTIONS

This experiment is very similar to the previous experiment using a bipolar junction transistor (BJT) as a switching device to control current through an LED. In this experiment, a *junction field-effect transistor* is used instead, giving dramatically improved sensitivity.

Build this circuit and touch the loose wire end (the wire shown in red on the schematic diagram and in the illustration, connected to the 100 k Ω resistor) with your hand. Simply touching this wire will likely have an effect on the LED's status. This circuit makes a fine sensor of static electricity! Try scuffing your feet on a carpet and then touching the wire end if no effect on the light is seen yet.

For a more controlled test, touch the wire with one hand and alternately touch the positive (+) and negative (-) terminals of the battery with one finger of your other hand. Your body acts as a conductor (albeit a poor one), connecting the gate terminal of the JFET to either terminal of the battery as you touch them. Make note which terminal makes the LED turn on and which makes the LED turn off. Try to relate this behavior with what you've read about JFETs in chapter 5 of the Semiconductor volume.

The fact that a JFET is turned on and off so easily (requiring so little control current), as evidenced by full on-and-off control simply by conduction of a control current through your body, demonstrates how great of a current gain it has. With the BJT "switch" experiment, a much more "solid" connection between the transistor's gate terminal and a source of voltage was needed to turn it on. Not so with the JFET. In fact, the mere presence of static electricity can turn it on and off at a distance.

To further experiment with the effects of static electricity on this circuit, brush your hair with the plastic comb and then wave the comb near the transistor, watching the effect on the LED. The action of combing your hair with a plastic object creates a high static voltage between the comb and your body. The strong electric field produced between these two objects should be detectable by this circuit from a significant distance!

In case you're wondering why there is no 560 Ω "dropping" resistor to limit current through the LED, many small-signal JFETs tend to self-limit their controlled current to a level acceptable by LEDs. The model 2N3819, for example, has a typical saturated drain current (I_{DSS}) of

10 mA and a maximum of 20 mA. Since most LEDs are rated at a forward current of 20 mA, there is no need for a dropping resistor to limit circuit current: the JFET does it intrinsically.

5.10 Pulsed-light sensor

PARTS AND MATERIALS

- Two 6-volt batteries
- One NPN transistor – models 2N2222 or 2N3403 recommended (Radio Shack catalog # 276-1617 is a package of fifteen NPN transistors ideal for this and other experiments)
- One light-emitting diode (Radio Shack catalog # 276-026 or equivalent)
- Audio detector with headphones

If you don't have an audio detector already constructed, you can use a nice set of audio headphones (closed-cup style, that completely covers your ears) and a 120V/6V step-down transformer to build a sensitive audio detector without volume control or overvoltage protection, just for this experiment.

Connect these portions of the headphone stereo plug to the transformer's secondary (6 volt) winding:

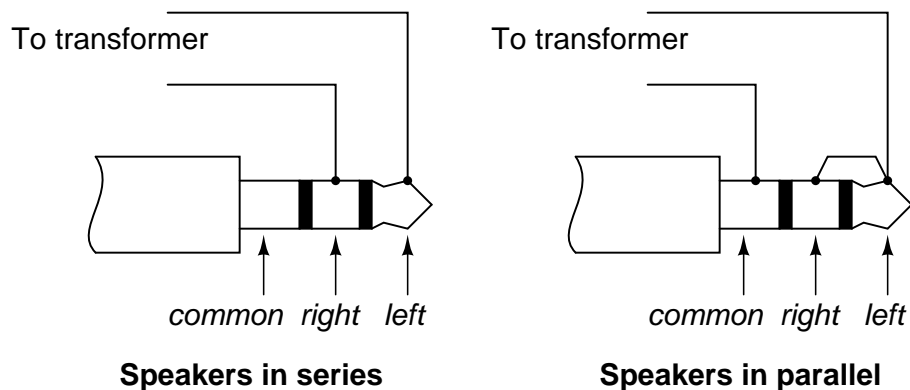

Try both the series and the parallel connection schemes for the loudest sound.

If you haven't made an audio detector as outlined in both the DC and AC experiments chapters, you really should – it is a valuable piece of test equipment for your collection.

CROSS-REFERENCES

Lessons In Electric Circuits, Volume 3, chapter 4: "Bipolar Junction Transistors"

LEARNING OBJECTIVES

- How to use a transistor as a crude common-emitter amplifier
- How to use an LED as a light sensor

SCHEMATIC DIAGRAM

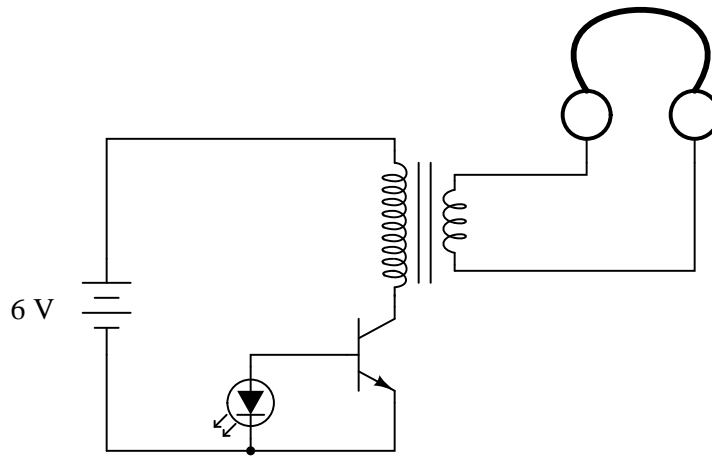

ILLUSTRATION

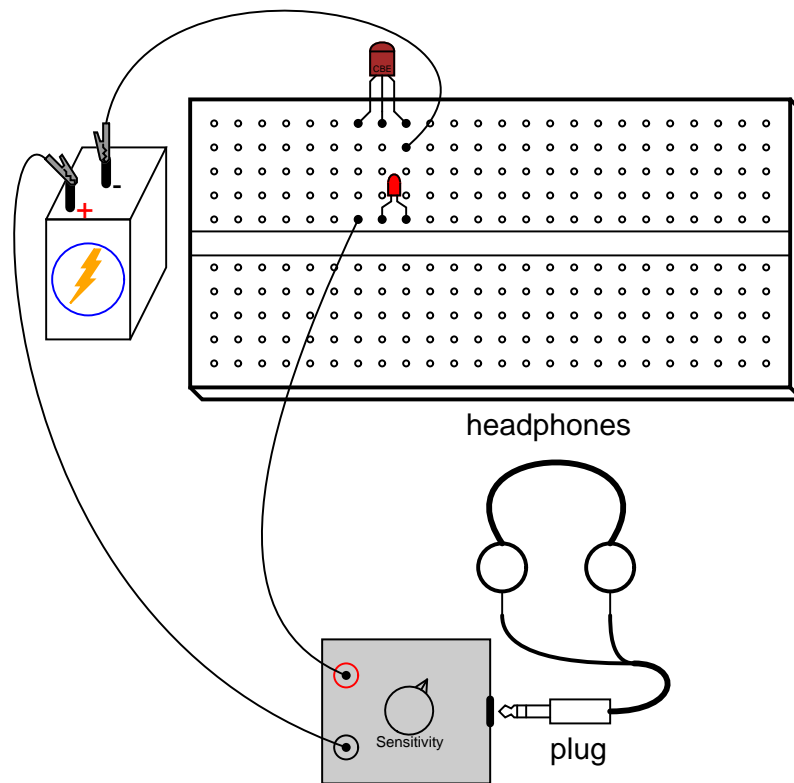

INSTRUCTIONS

This circuit detects pulses of light striking the LED and converts them into relatively strong audio signals to be heard through the headphones. Forrest Mims teaches that LEDs have the

ability to *produce* current when exposed to light, in a manner not unlike a semiconductor solar cell. [1] By itself, the LED does not produce enough electrical power to drive the audio detector circuit, so a transistor is used to amplify the LED's signals. If the LED is exposed to a pulsing source of light, a tone will be heard in the headphones.

Sources of light suitable for this experiment include fluorescent and neon lamps, which blink rapidly with the 60 Hz AC power energizing them. You may also try using bright sunlight for a steady light source, then waving your fingers in front of the LED. The rapidly passing shadows will cause the LED to generate pulses of voltage, creating a brief "buzzing" sound in the headphones.

LEDs serving as photo-detectors are narrow-band devices, responding to a narrow band of wavelengths close, but not identical, to that normally emitted. Infrared remote controls are a good illumination source for near-infrared LEDs employed as photo-sensors, producing a receiver sound. [3]

With a little imagination, it is not difficult to grasp the concept of transmitting audio information – such as music or speech – over a beam of pulsing light. Given a suitable "transmitter" circuit to pulse an LED on and off with the positive and negative crests of an audio waveform from a microphone, the "receiver" circuit shown here would convert those light pulses back into audio signals. [2]

5.11 Voltage follower

PARTS AND MATERIALS

- One NPN transistor – models 2N2222 or 2N3403 recommended (Radio Shack catalog # 276-1617 is a package of fifteen NPN transistors ideal for this and other experiments)
- Two 6-volt batteries
- Two 1 k Ω resistors
- One 10 k Ω potentiometer, single-turn, linear taper (Radio Shack catalog # 271-1715)

Beware that not all transistors share the same terminal designations, or *pinouts*, even if they share the same physical appearance. This will dictate how you connect the transistors together and to other components, so be sure to check the manufacturer's specifications (component datasheet), easily obtained from the manufacturer's website. Beware that it is possible for the transistor's package and even the manufacturer's datasheet to show incorrect terminal identification diagrams! Double-checking pin identities with your multimeter's "diode check" function is highly recommended. For details on how to identify bipolar transistor terminals using a multimeter, consult chapter 4 of the Semiconductor volume (volume III) of this book series.

CROSS-REFERENCES

Lessons In Electric Circuits, Volume 3, chapter 4: "Bipolar Junction Transistors"

LEARNING OBJECTIVES

- Purpose of circuit "ground" when there is no actual connection to earth ground
- Using a shunt resistor to measure current with a voltmeter
- Measure amplifier voltage gain
- Measure amplifier current gain
- Amplifier impedance transformation

SCHEMATIC DIAGRAM

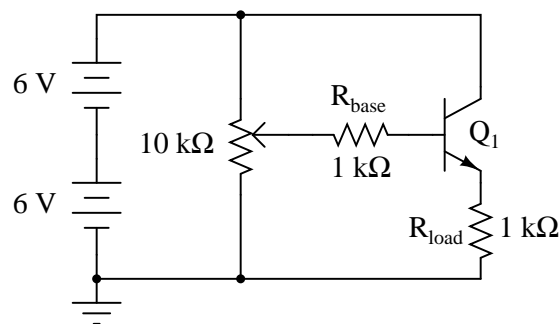

ILLUSTRATION

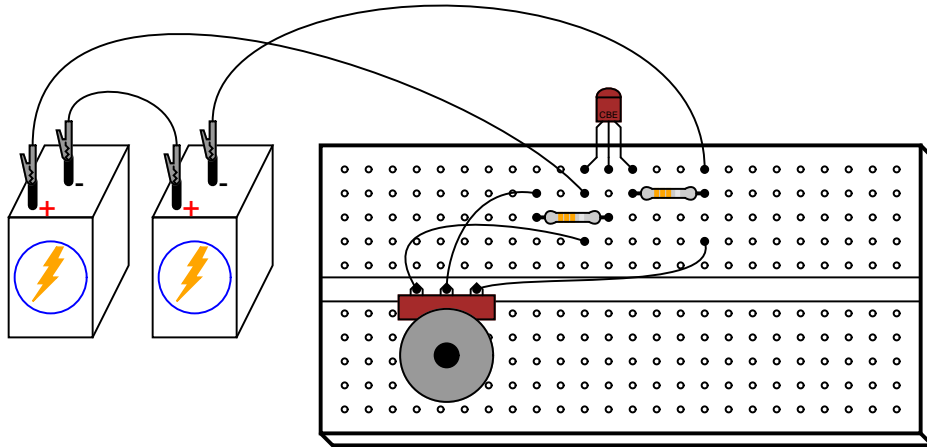

INSTRUCTIONS

Again, beware that the transistor you select for this experiment may not have the same terminal designations shown here, and so the breadboard layout shown in the illustration may not be correct for you. In my illustrations, I show all TO-92 package transistors with terminals labeled "CBE": Collector, Base, and Emitter, from left to right. This is correct for the model 2N2222 transistor and some others, *but not for all*; not even for all NPN-type transistors! As usual, check with the manufacturer for details on the particular component(s) you choose for a project. With bipolar junction transistors, it is easy enough to verify terminal assignments with a multimeter.

The *voltage follower* is the safest and easiest transistor amplifier circuit to build. Its purpose is to provide approximately the same voltage to a load as what is input to the amplifier, but at a much greater current. In other words, it has no voltage gain, but it does have current gain.

Note that the negative (-) side of the power supply is shown in the schematic diagram to be connected to *ground*, as indicated by the symbol in the lower-left corner of the diagram. This does not necessarily represent a connection to the actual earth. What it means is that this point in the circuit – and all points electrically common to it – constitute the default reference point for all voltage measurements in the circuit. Since voltage is by necessity a quantity relative between two points, a "common" point of reference designated in a circuit gives us the ability to speak meaningfully of voltage at particular, single points in that circuit.

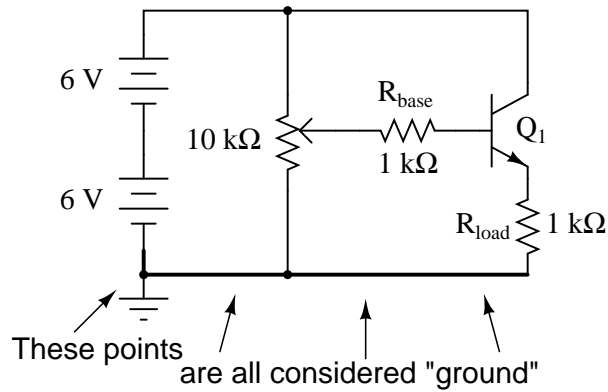

For example, if I were to speak of voltage *at* the base of the transistor (V_B), I would mean the voltage measured between the transistor's base terminal and the negative side of the power supply (ground), with the red probe touching the base terminal and the black probe touching ground. Normally, it is nonsense to speak of voltage *at* a single point, but having an implicit reference point for voltage measurements makes such statements meaningful:

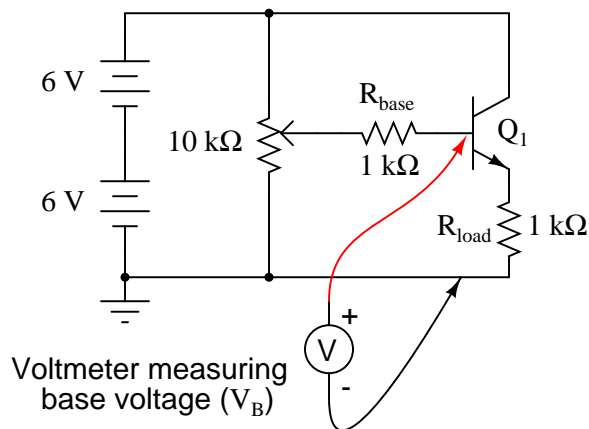

Build this circuit, and measure output voltage versus input voltage for several different potentiometer settings. Input voltage is the voltage at the potentiometer's wiper (voltage between the wiper and circuit ground), while output voltage is the load resistor voltage (voltage across the load resistor, or emitter voltage: between emitter and circuit ground). You should see a close correlation between these two voltages: one is just a little bit greater than the other (about 0.6 volts or so?), but a change in the input voltage gives almost equal change in the output voltage. Because the relationship between input *change* and output *change* is almost 1:1, we say that the AC voltage gain of this amplifier is nearly 1.

Not very impressive, is it? Now measure current through the base of the transistor (input current) versus current through the load resistor (output current). Before you break the circuit and insert your ammeter to take these measurements, consider an alternative method: measure *voltage* across the base and load resistors, whose resistance values are known. Using Ohm's Law, current through each resistor may be easily calculated: divide the measured volt-

age by the known resistance ($I=E/R$). This calculation is particularly easy with resistors of $1\text{ k}\Omega$ value: there will be 1 milliamp of current for every volt of drop across them. For best precision, you may measure the resistance of each resistor rather than assume an exact value of $1\text{ k}\Omega$, but it really doesn't matter much for the purposes of this experiment. When resistors are used to take current measurements by "translating" a current into a corresponding voltage, they are often referred to as *shunt* resistors.

You should expect to find huge differences between input and output currents for this amplifier circuit. In fact, it is not uncommon to experience current gains well in excess of 200 for a small-signal transistor operating at low current levels. This is the primary purpose of a voltage follower circuit: to boost the current capacity of a "weak" signal without altering its voltage.

Another way of thinking of this circuit's function is in terms of *impedance*. The input side of this amplifier accepts a voltage signal without drawing much current. The output side of this amplifier delivers the same voltage, but at a current limited only by load resistance and the current-handling ability of the transistor. Cast in terms of impedance, we could say that this amplifier has a high input impedance (voltage dropped with very little current drawn) and a low output impedance (voltage dropped with almost unlimited current-sourcing capacity).

COMPUTER SIMULATION

Schematic with SPICE node numbers:

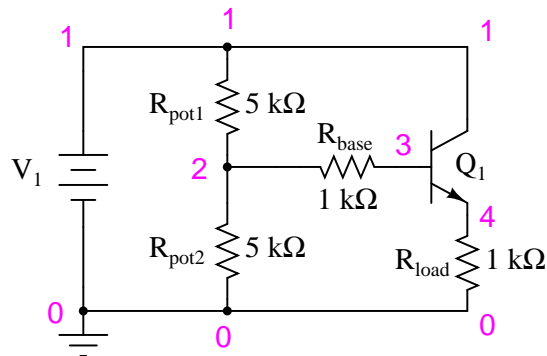

Netlist (make a text file containing the following text, verbatim):

```
Voltage follower
v1 1 0
rpot1 1 2 5k
rpot2 2 0 5k
rbase 2 3 1k
rload 4 0 1k
q1 1 3 4 mod1
.model mod1 npn bf=200
.dc v1 12 12 1
.print dc v(2,0) v(4,0) v(2,3)
.end
```

When this simulation is run through the SPICE program, it shows an input voltage of 5.937 volts and an output voltage of 5.095 volts, with an input current of 25.35 μA (2.535E-02 volts dropped across the 1 k Ω R_{base} resistor). Output current is, of course, 5.095 mA, inferred from the output voltage of 5.095 volts dropped across a load resistance of exactly 1 k Ω . You may change the "potentiometer" setting in this circuit by adjusting the values of R_{pot1} and R_{pot2} , always keeping their sum at 10 k Ω .

5.12 Common-emitter amplifier

PARTS AND MATERIALS

- One NPN transistor – model 2N2222 or 2N3403 recommended (Radio Shack catalog # 276-1617 is a package of fifteen NPN transistors ideal for this and other experiments)
- Two 6-volt batteries
- One 10 k Ω potentiometer, single-turn, linear taper (Radio Shack catalog # 271-1715)
- One 1 M Ω resistor
- One 100 k Ω resistor
- One 10 k Ω resistor
- One 1.5 k Ω resistor

CROSS-REFERENCES

Lessons In Electric Circuits, Volume 3, chapter 4: "Bipolar Junction Transistors"

LEARNING OBJECTIVES

- Design of a simple common-emitter amplifier circuit
- How to measure amplifier voltage gain
- The difference between an inverting and a noninverting amplifier
- Ways to introduce negative feedback in an amplifier circuit

SCHEMATIC DIAGRAM

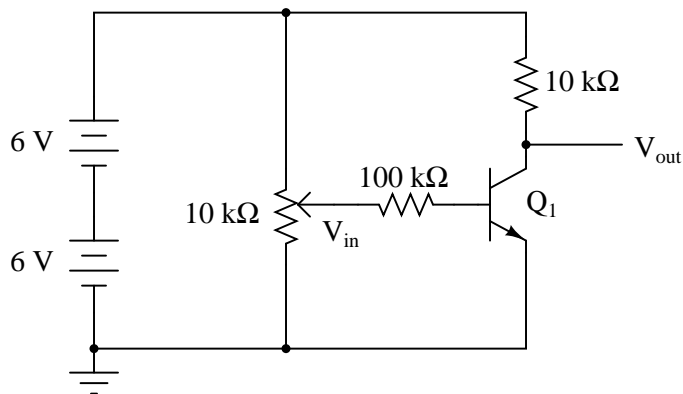

ILLUSTRATION

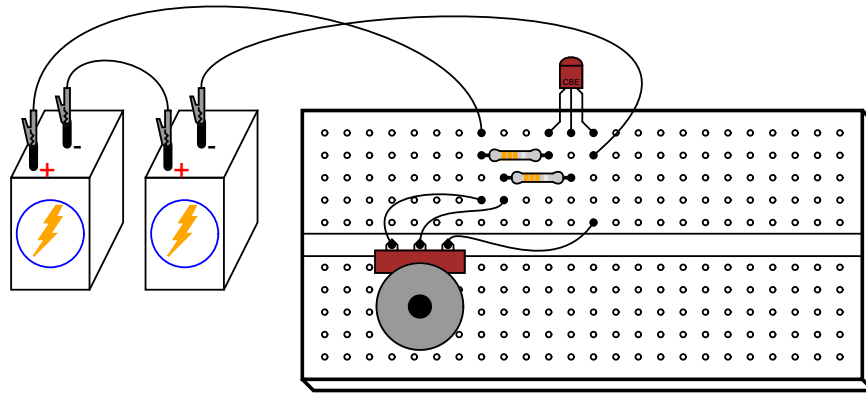

INSTRUCTIONS

Build this circuit and measure output voltage (voltage measured between the transistor's collector terminal and ground) and input voltage (voltage measured between the potentiometer's wiper terminal and ground) for several position settings of the potentiometer. I recommend determining the output voltage range as the potentiometer is adjusted through its entire range of motion, then choosing several voltages spanning that output range to take measurements at. For example, if full rotation on the potentiometer drives the amplifier circuit's output voltage from 0.1 volts (low) to 11.7 volts (high), choose several voltage levels between those limits (1 volt, 3 volts, 5 volts, 7 volts, 9 volts, and 11 volts). Measuring the output voltage with a meter, adjust the potentiometer to obtain each of these predetermined voltages at the output, noting the exact figure for later reference. Then, measure the exact input voltage producing that output voltage, and record that voltage figure as well.

In the end, you should have a table of numbers representing several different output voltages along with their corresponding input voltages. Take any two pairs of voltage figures and calculate voltage gain by dividing the difference in output voltages by the difference in input voltages. For example, if an input voltage of 1.5 volts gives me an output voltage of 7.0 volts and an input voltage of 1.66 volts gives me an output voltage of 1.0 volt, the amplifier's voltage gain is $(7.0 - 1.0)/(1.66 - 1.5)$, or 6 divided by 0.16: a gain ratio of 37.50.

You should immediately notice two characteristics while taking these voltage measurements: first, that the input-to-output effect is "reversed;" that is, an *increasing* input voltage results in a *decreasing* output voltage. This effect is known as signal inversion, and this kind of amplifier as an *inverting* amplifier. Secondly, this amplifier exhibits a very strong voltage gain: a small change in input voltage results in a large change in output voltage. This should stand in stark contrast to the "voltage follower" amplifier circuit discussed earlier, which had a voltage gain of about 1.

Common-emitter amplifiers are widely used due to their high voltage gain, but they are rarely used in as crude a form as this. Although this amplifier circuit works to demonstrate the basic concept, it is very susceptible to changes in temperature. Try leaving the potentiometer in one position and heating the transistor by grasping it firmly with your hand or heating it with some other source of heat such as an electric hair dryer (**WARNING:** be careful not to get it so hot that your plastic breadboard melts!). You may also explore temperature effects by cooling the transistor: touch an ice cube to its surface and note the change in output voltage.

When the transistor's temperature changes, its base-emitter diode characteristics change, resulting in different amounts of base current for the same input voltage. This in turn alters the controlled current through the collector terminal, thus affecting output voltage. Such changes may be minimized through the use of signal *feedback*, whereby a portion of the output voltage is "fed back" to the amplifier's input so as to have a negative, or canceling, effect on voltage gain. Stability is improved at the expense of voltage gain, a compromise solution, but practical nonetheless.

Perhaps the simplest way to add negative feedback to a common-emitter amplifier is to add some resistance between the emitter terminal and ground, so that the input voltage becomes divided between the base-emitter PN junction and the voltage drop across the new resistance:

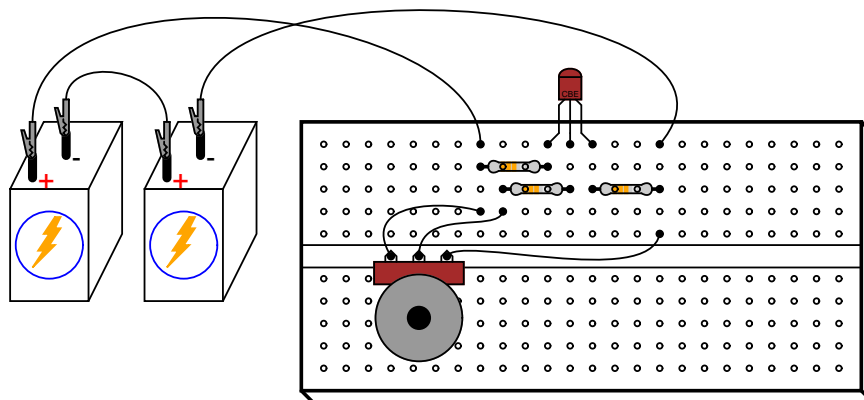
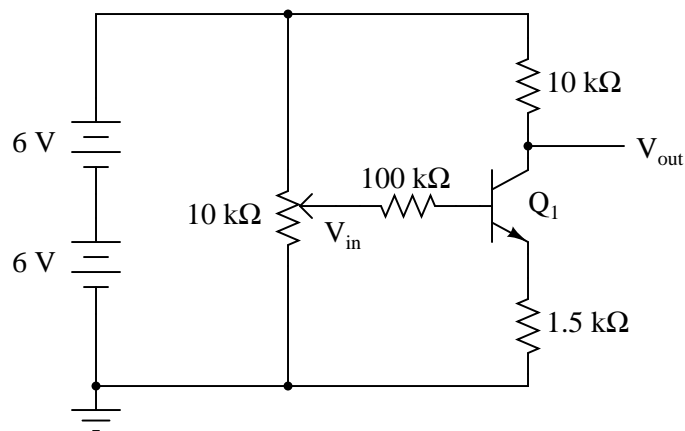

Repeat the same voltage measurement and recording exercise with the 1.5 kΩ resistor installed, calculating the new (reduced) voltage gain. Try altering the transistor's temperature again and noting the output voltage for a steady input voltage. Does it change more or less than without the 1.5 kΩ resistor?

Another method of introducing negative feedback to this amplifier circuit is to "couple" the output to the input through a high-value resistor. Connecting a 1 MΩ resistor between the transistor's collector and base terminals works well:

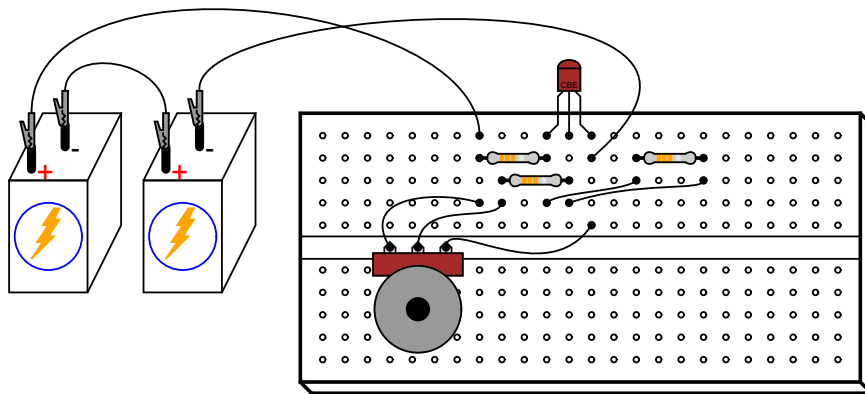
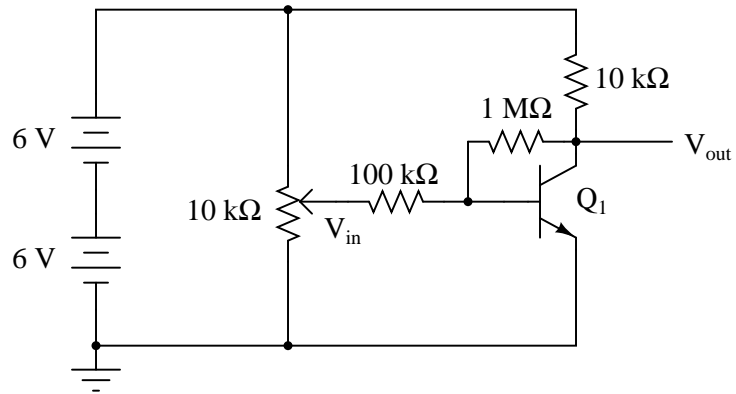

Although this different method of feedback accomplishes the same goal of increased stability by diminishing gain, the two feedback circuits will not behave identically. Note the range of possible output voltages with each feedback scheme (the low and high voltage values obtained with a full sweep of the input voltage potentiometer), and how this differs between the two circuits.

COMPUTER SIMULATION

Schematic with SPICE node numbers:

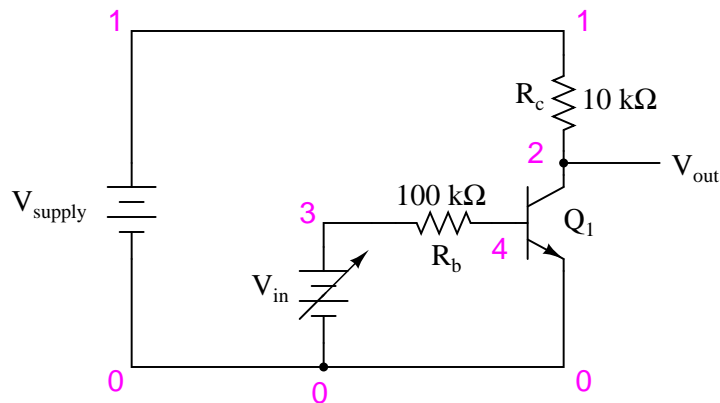

Netlist (make a text file containing the following text, verbatim):

```
Common-emitter amplifier
vsupply 1 0 dc 12
vin 3 0
rc 1 2 10k
rb 3 4 100k
q1 2 4 0 mod1
.model mod1 npn bf=200
.dc vin 0 2 0.05
.plot dc v(2,0) v(3,0)
.end
```

This SPICE simulation sets up a circuit with a variable DC voltage source (v_{in}) as the input signal, and measures the corresponding output voltage between nodes 2 and 0. The input voltage is varied, or "swept," from 0 to 2 volts in 0.05 volt increments. Results are shown on a plot, with the input voltage appearing as a straight line and the output voltage as a "step" figure where the voltage begins and ends level, with a steep change in the middle where the transistor is in its active mode of operation.

5.13 Multi-stage amplifier

PARTS AND MATERIALS

- Three NPN transistors – model 2N2222 or 2N3403 recommended (Radio Shack catalog # 276-1617 is a package of fifteen NPN transistors ideal for this and other experiments)
- Two 6-volt batteries
- One 10 k Ω potentiometer, single-turn, linear taper (Radio Shack catalog # 271-1715)
- One 1 M Ω resistor
- Three 100 k Ω resistors
- Three 10 k Ω resistors

CROSS-REFERENCES

Lessons In Electric Circuits, Volume 3, chapter 4: "Bipolar Junction Transistors"

LEARNING OBJECTIVES

- Design of a multi-stage, direct-coupled common-emitter amplifier circuit
- Effect of negative feedback in an amplifier circuit

SCHEMATIC DIAGRAM

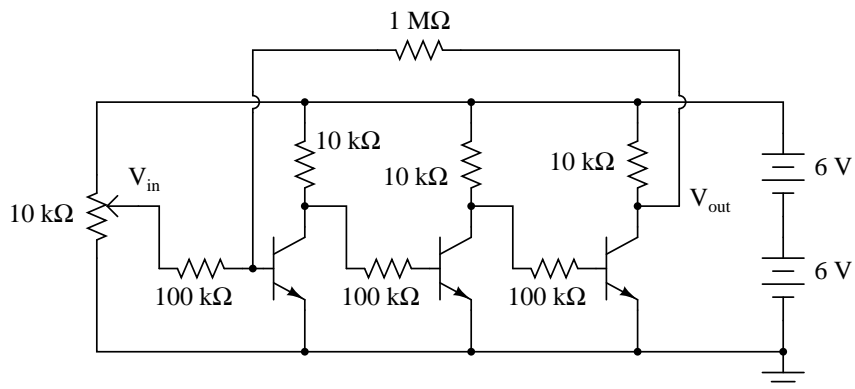

ILLUSTRATION

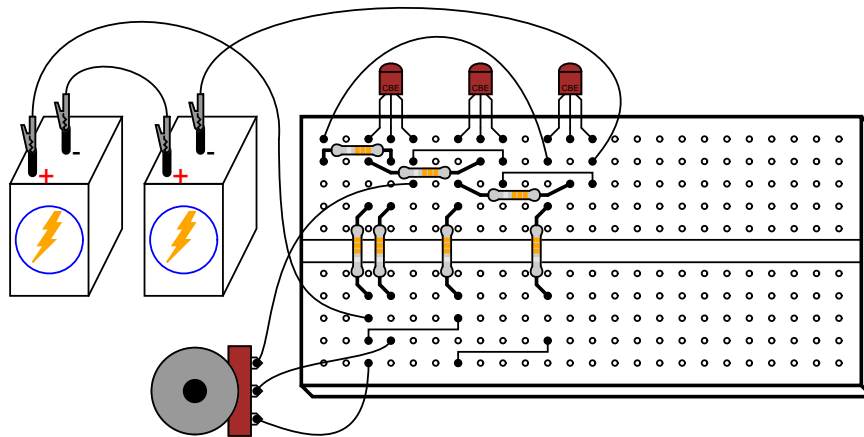

INSTRUCTIONS

By connecting three common-emitter amplifier circuit together – the collector terminal of the previous transistor to the base (resistor) of the next transistor – the voltage gains of each stage compound to give a very high overall voltage gain. I recommend building this circuit *without* the $1\text{ M}\Omega$ feedback resistor to begin with, to see for yourself just how high the unrestricted voltage gain is. You may find it impossible to adjust the potentiometer for a stable output voltage (that isn't saturated at full supply voltage or zero), the gain being so high.

Even if you can't adjust the input voltage fine enough to stabilize the output voltage in the active range of the last transistor, you should be able to tell that the output-to-input relationship is inverting; that is, the output tends to drive to a high voltage when the input goes low, and vice versa. Since any one of the common-emitter "stages" is inverting in itself, an even number of staged common-emitter amplifiers gives noninverting response, while an odd number of stages gives inverting. You may experience these relationships by measuring the collector-to-ground voltage *at each transistor* while adjusting the input voltage potentiometer, noting whether or not the output voltage increases or decreases with an increase in input voltage.

Connect the $1\text{ M}\Omega$ feedback resistor into the circuit, coupling the collector of the last transistor to the base of the first. Since the overall response of this three-stage amplifier is inverting, the feedback signal provided through the $1\text{ M}\Omega$ resistor from the output of the last transistor to the input of the first should be *negative* in nature. As such, it will act to stabilize the amplifier's response and minimize the voltage gain. You should notice the reduction in gain immediately by the decreased sensitivity of the output signal on input signal changes (changes in potentiometer position). Simply put, the amplifier isn't nearly as "touchy" as it was without the feedback resistor in place.

As with the simple common-emitter amplifier discussed in an earlier experiment, it is a good idea here to make a table of input versus output voltage figures with which you may calculate voltage gain.

Experiment with different values of feedback resistance. What effect do you think a *decrease* in feedback resistance have on voltage gain? What about an *increase* in feedback resistance? Try it and find out!

An advantage of using negative feedback to "tame" a high-gain amplifier circuit is that the resulting voltage gain becomes more dependent upon the resistor values and less dependent upon the characteristics of the constituent transistors. This is good, because it is far easier to manufacture consistent resistors than consistent transistors. Thus, it is easier to design an amplifier with predictable gain by building a staged network of transistors with an arbitrarily high voltage gain, then mitigate that gain precisely through negative feedback. It is this same principle that is used to make *operational amplifier* circuits behave so predictably.

This amplifier circuit is a bit simplified from what you will normally encounter in practical multi-stage circuits. Rarely is a pure common-emitter configuration (i.e. with no emitter-to-ground resistor) used, and if the amplifier's service is for AC signals, the inter-stage coupling is often capacitive with voltage divider networks connected to each transistor base for proper biasing of each stage. Radio-frequency amplifier circuits are often transformer-coupled, with capacitors connected in parallel with the transformer windings for resonant tuning.

COMPUTER SIMULATION

Schematic with SPICE node numbers:

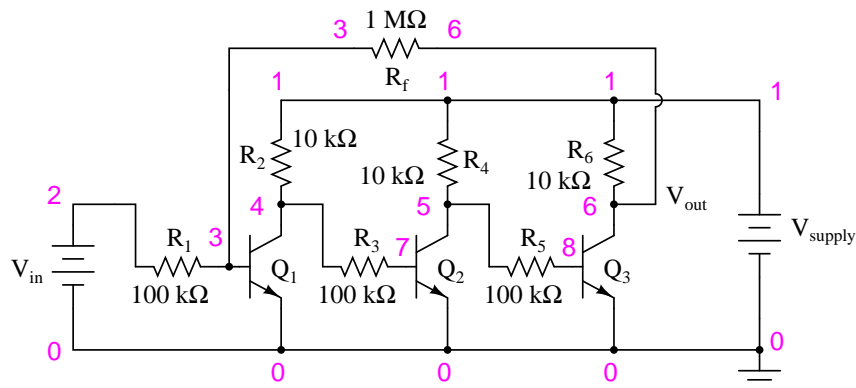

Netlist (make a text file containing the following text, verbatim):

```
Multi-stage amplifier
vsupply 1 0 dc 12
vin 2 0
r1 2 3 100k
r2 1 4 10k
q1 4 3 0 mod1
r3 4 7 100k
r4 1 5 10k
q2 5 7 0 mod1
r5 5 8 100k
r6 1 6 10k
q3 6 8 0 mod1
rf 3 6 1meg
.model mod1 npn bf=200
.dc vin 0 2.5 0.1
```

```
.plot dc v(6,0) v(2,0)
.end
```

This simulation plots output voltage against input voltage, and allows comparison between those variables in numerical form: a list of voltage figures printed to the left of the plot. You may calculate voltage gain by taking any two analysis points and dividing the difference in output voltages by the difference in input voltages, just like you do for the real circuit.

Experiment with different feedback resistance values (r_f) and see the impact on overall voltage gain. Do you notice a pattern? Here's a hint: the overall voltage gain may be closely approximated by using the resistance figures of r_1 and r_f , without reference to any other circuit component!

5.14 Current mirror

PARTS AND MATERIALS

- Two NPN transistors – models 2N2222 or 2N3403 recommended (Radio Shack catalog # 276-1617 is a package of fifteen NPN transistors ideal for this and other experiments)
- Two 6-volt batteries
- One 10 k Ω potentiometer, single-turn, linear taper (Radio Shack catalog # 271-1715)
- Two 10 k Ω resistors
- Four 1.5 k Ω resistors

Small signal transistors are recommended so as to be able to experience "thermal runaway" in the latter portion of the experiment. Larger "power" transistors may not exhibit the same behavior at these low current levels. However, *any* pair of identical NPN transistors may be used to build a current mirror.

Beware that not all transistors share the same terminal designations, or *pinouts*, even if they share the same physical appearance. This will dictate how you connect the transistors together and to other components, so be sure to check the manufacturer's specifications (component datasheet), easily obtained from the manufacturer's website. Beware that it is possible for the transistor's package and even the manufacturer's datasheet to show incorrect terminal identification diagrams! Double-checking pin identities with your multimeter's "diode check" function is highly recommended. For details on how to identify bipolar transistor terminals using a multimeter, consult chapter 4 of the Semiconductor volume (volume III) of this book series.

CROSS-REFERENCES

Lessons In Electric Circuits, Volume 3, chapter 4: "Bipolar Junction Transistors"

LEARNING OBJECTIVES

- How to build a current mirror circuit
- Current limitations of a current mirror circuit
- Temperature dependence of BJTs
- Experience a controlled "thermal runaway" situation

SCHEMATIC DIAGRAM

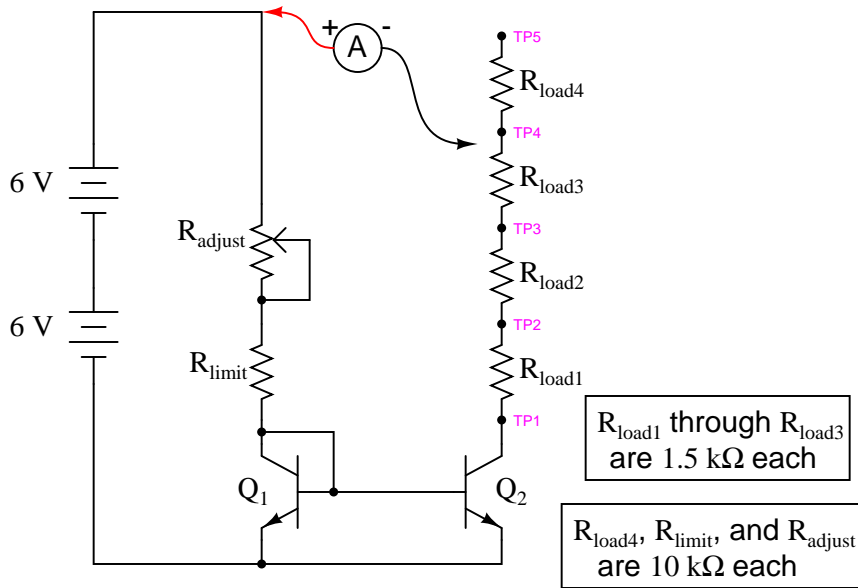

ILLUSTRATION

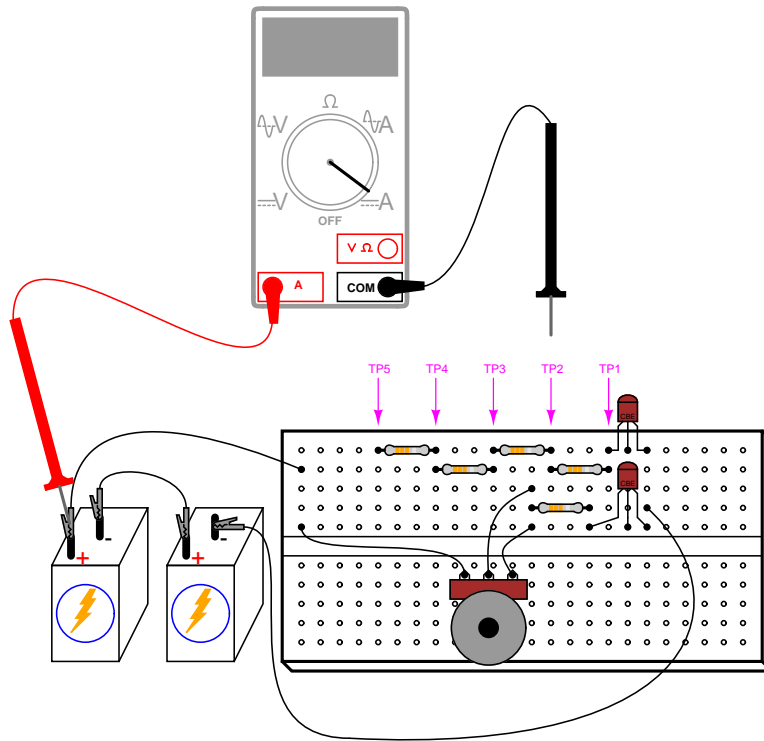

INSTRUCTIONS

A current mirror may be thought of as an *adjustable current regulator*, the current limit being easily set by a single resistance. It is a rather crude current regulator circuit, but one that finds wide use due to its simplicity. In this experiment, you will get the opportunity to build one of these circuits, explore its current-regulating properties, and also experience some of its practical limitations firsthand.

Build the circuit as shown in the schematic and illustration. You will have one extra 1.5 k Ω fixed-value resistor from the parts specified in the parts list. You will be using it in the last part of this experiment.

The potentiometer sets the amount of current through transistor Q_1 . This transistor is connected to act as a simple diode: just a PN junction. Why use a transistor instead of a regular diode? Because it is important to *match* the junction characteristics of these two transistors when using them in a current mirror circuit. Voltage dropped across the base-emitter junction of Q_1 is impressed across the base-emitter junction of the other transistor, Q_2 , causing it to turn "on" and likewise conduct current.

Since voltage across the two transistors' base-emitter junctions is the same – the two junction pairs being connected in parallel with each other – so should the current be through their base terminals, assuming identical junction characteristics and identical junction temperatures. Matched transistors should have the same β ratios, as well, so equal base currents means equal collector currents. The practical result of all this is Q_2 's collector current mimicking whatever current magnitude has been established through the collector of Q_1 by the potentiometer. In other words, current through Q_2 *mirrors* the current through Q_1 .

Changes in load resistance (resistance connecting the collector of Q_2 to the positive side of the battery) have no effect on Q_1 's current, and consequently have no effect upon the base-emitter voltage or base current of Q_2 . With a constant base current and a nearly constant β ratio, Q_2 will drop as much or as little collector-emitter voltage as necessary to hold its collector (load) current constant. Thus, the current mirror circuit acts to *regulate* current at a value set by the potentiometer, without regard to load resistance.

Well, that is how it is supposed to work, anyway. Reality isn't quite so simple, as you are about to see. In the circuit diagram shown, the load circuit of Q_2 is completed to the positive side of the battery through an ammeter, for easy current measurement. Rather than solidly connect the ammeter's black probe to a definite point in the circuit, I've marked five *test points*, TP1 through TP5, for you to touch the black test probe to while measuring current. This allows you to quickly and effortlessly change load resistance: touching the probe to TP1 results in practically no load resistance, while touching it to TP5 results in approximately 14.5 k Ω of load resistance.

To begin the experiment, touch the test probe to TP4 and adjust the potentiometer through its range of travel. You should see a small, changing current indicated by your ammeter as you move the potentiometer mechanism: no more than a few milliamperes. Leave the potentiometer set to a position giving a round number of milliamperes and move the meter's black test probe to TP3. The current indication should be very nearly the same as before. Move the probe to TP2, then TP1. Again, you should see a nearly unchanged amount of current. Try adjusting the potentiometer to another position, giving a different current indication, and touch the meter's black probe to test points TP1 through TP4, noting the stability of the current indications as you change load resistance. This demonstrates the current *regulating* behavior of this circuit.

You should note that the current regulation isn't perfect. Despite regulating the current at *nearly* the value for load resistances between 0 and 4.5 k Ω , there is some variation over this range. The regulation may be much worse if load resistance is allowed to rise too high. Try adjusting the potentiometer so that maximum current is obtained, as indicated with the ammeter test probe connected to TP1. Leaving the potentiometer at that position, move the meter probe to TP2, then TP3, then TP4, and finally TP5, noting the meter's indication at each connection point. The current should be regulated at a nearly constant value until the meter probe is moved to the last test point, TP5. There, the current indication will be substantially lower than at the other test points. Why is this? Because too much load resistance has been inserted into Q₂'s circuit. Simply put, Q₂ cannot "turn on" any more than it already has, to maintain the same amount of current with this great a load resistance as with lesser load resistances.

This phenomenon is common to all current-regulator circuits: there is a limited amount of resistance a current regulator can handle before it *saturates*. This stands to reason, as any current regulator circuit capable of supplying a constant amount of current through *any* load resistance imaginable would require an unlimited source of voltage to do it! Ohm's Law ($E=IR$) dictates the amount of voltage needed to push a given amount of current through a given amount of resistance, and with only 12 volts of power supply voltage at our disposal, a finite limit of load current and load resistance definitely exists for this circuit. For this reason, it may be helpful to think of current regulator circuits as being current *limiter* circuits, for all they can really do is limit current to some maximum value.

An important caveat for current mirror circuits in general is that of equal temperature between the two transistors. The current "mirroring" taking place between the two transistors' collector circuits depends on the base-emitter junctions of those two transistors having the exact same properties. As the "diode equation" describes, the voltage/current relationship for a PN junction strongly depends on junction *temperature*. The hotter a PN junction is, the more current it will pass for a given amount of voltage drop. If one transistor should become hotter than the other, it will pass more collector current than the other, and the circuit will no longer "mirror" current as expected. When building a real current mirror circuit using discrete transistors, the two transistors should be epoxy-glued together (back-to-back) so that they remain at approximately the same temperature.

To illustrate this dependence on equal temperature, try grasping one transistor between your fingers to heat it up. What happens to the current through the load resistors as the transistor's temperature increases? Now, let go of the transistor and blow on it to cool it down to ambient temperature. Grasp the *other* transistor between your fingers to heat it up. What does the load current do now?

In this next phase of the experiment, we will intentionally allow one of the transistors to overheat and note the effects. To avoid damaging a transistor, this procedure should be conducted no longer than is necessary to observe load current begin to "run away." To begin, adjust the potentiometer for minimum current. Next, replace the 10 k Ω R_{limit} resistor with a 1.5 k Ω resistor. This will allow a higher current to pass through Q₁, and consequently through Q₂ as well.

Place the ammeter's black probe on TP1 and observe the current indication. Move the potentiometer in the direction of increasing current until you read about 10 mA through the ammeter. At that point, stop moving the potentiometer and just observe the current. You will notice current begin to increase all on its own, without further potentiometer motion! Break

the circuit by removing the meter probe from TP1 when the current exceeds 30 mA, to avoid damaging transistor Q_2 .

If you carefully touch both transistors with a finger, you should notice Q_2 is warm, while Q_1 is cool. **Warning:** if Q_2 's current has been allowed to "run away" too far or for too long a time, it may become **very hot!** You can receive a bad burn on your fingertip by touching an overheated semiconductor component, so be careful here!

What just happened to make Q_2 overheat and lose current control? By connecting the ammeter to TP1, all load resistance was removed, so Q_2 had to drop full battery voltage between collector and emitter as it regulated current. Transistor Q_1 at least had the $1.5\text{ k}\Omega$ resistance of R_{limit} in place to drop most of the battery voltage, so its power dissipation was far less than that of Q_2 . This gross imbalance of power dissipation caused Q_2 to heat more than Q_1 . As the temperature increased, Q_2 began to pass more current for the same amount of base-emitter voltage drop. This caused it to heat up even faster, as it was passing more collector current while still dropping the full 12 volts between collector and emitter. The effect is known as *thermal runaway*, and it is possible in many bipolar junction transistor circuits, not just current mirrors.

COMPUTER SIMULATION

Schematic with SPICE node numbers:

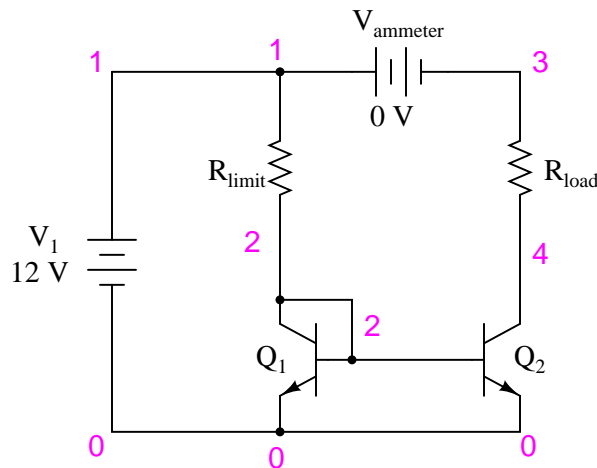

Netlist (make a text file containing the following text, verbatim):

```
Current mirror
v1 1 0
vammeter 1 3 dc 0
rlimit 1 2 10k
rload 3 4 3k
q1 2 2 0 mod1
q2 4 2 0 mod1
.model mod1 npn bf=100
.dc v1 12 12 1
```

```
.print dc i(vammeter)
.end
```

$V_{ammeter}$ is nothing more than a zero-volt DC battery strategically placed to intercept load current. This is nothing more than a trick to measure current in a SPICE simulation, as no dedicated "ammeter" component exists in the SPICE language.

It is important to remember that SPICE only recognizes the first eight characters of a component's name. The name "vammeter" is okay, but if we were to incorporate more than one current-measuring voltage source in the circuit and name them "vammeter1" and "vammeter2", respectively, SPICE would see them as being two instances of the same component "vammeter" (seeing only the first eight characters) and halt with an error. Something to bear in mind when altering the netlist or programming your own SPICE simulation!

You will have to experiment with different resistance values of R_{load} in this simulation to appreciate the current-regulating nature of the circuit. With R_{limit} set to 10 k Ω and a power supply voltage of 12 volts, the regulated current through R_{load} will be 1.1 mA. SPICE shows the regulation to be perfect (isn't the virtual world of computer simulation so nice?), the load current remaining at 1.1 mA for a *wide* range of load resistances. However, if the load resistance is increased beyond 10 k Ω , even this simulation shows the load current suffering a decrease as in real life.

5.15 JFET current regulator

PARTS AND MATERIALS

- One N-channel junction field-effect transistor, models 2N3819 or J309 recommended (Radio Shack catalog # 276-2035 is the model 2N3819)
- Two 6-volt batteries
- One 10 k Ω potentiometer, single-turn, linear taper (Radio Shack catalog # 271-1715)
- One 1 k Ω resistor
- One 10 k Ω resistor
- Three 1.5 k Ω resistors

For this experiment you will need an N-channel JFET, not a P-channel!

Beware that not all transistors share the same terminal designations, or *pinouts*, even if they share the same physical appearance. This will dictate how you connect the transistors together and to other components, so be sure to check the manufacturer's specifications (component datasheet), easily obtained from the manufacturer's website. Beware that it is possible for the transistor's package and even the manufacturer's datasheet to show incorrect terminal identification diagrams! Double-checking pin identities with your multimeter's "diode check" function is highly recommended. For details on how to identify junction field-effect transistor terminals using a multimeter, consult chapter 5 of the Semiconductor volume (volume III) of this book series.

CROSS-REFERENCES

Lessons In Electric Circuits, Volume 3, chapter 5: "Junction Field-Effect Transistors"

Lessons In Electric Circuits, Volume 3, chapter 3: "Diodes and Rectifiers"

LEARNING OBJECTIVES

- How to use a JFET as a current regulator
- How the JFET is relatively immune to changes in temperature

SCHEMATIC DIAGRAM

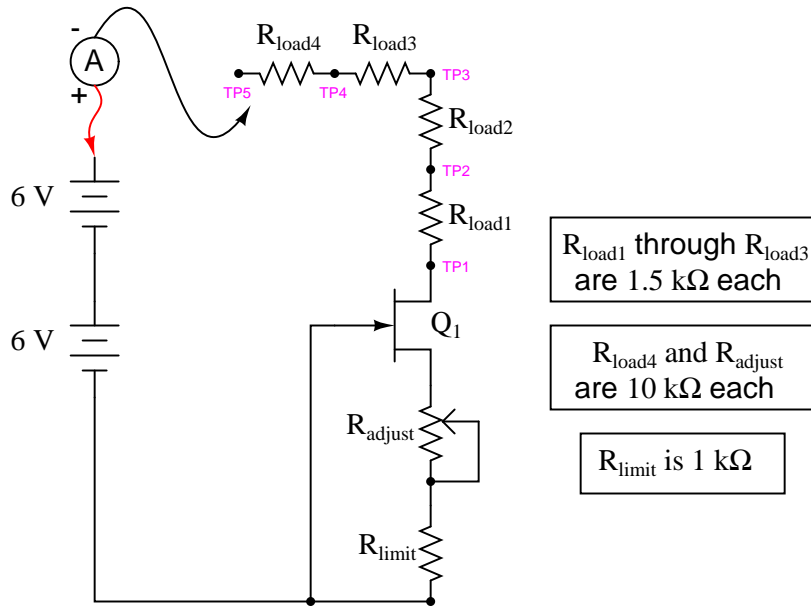

ILLUSTRATION

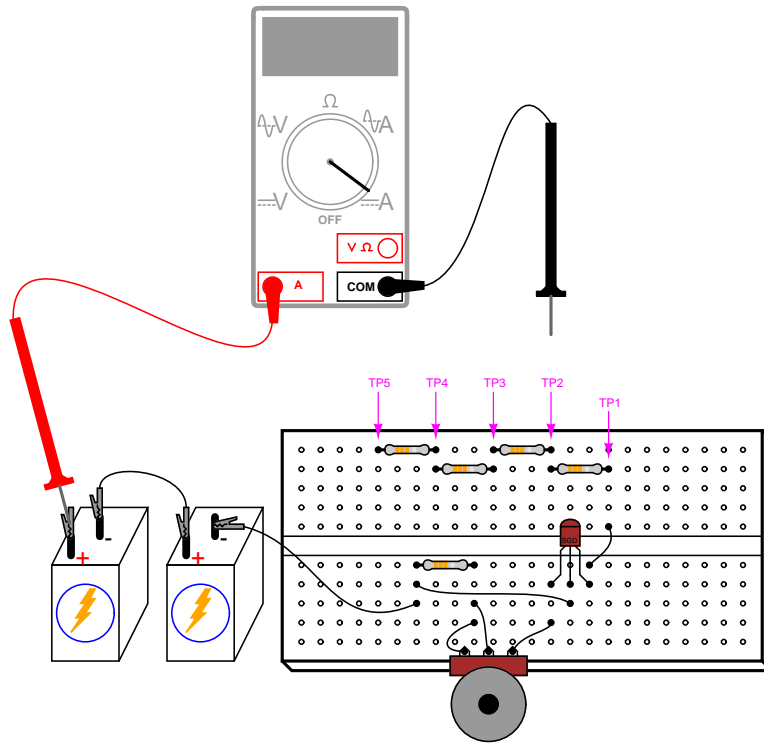

INSTRUCTIONS

Previously in this chapter, you saw how a pair of bipolar junction transistors (BJTs) could be used to form a *current mirror*, whereby one transistor would try to maintain the same current through it as through the other, the other's current level being established by a variable resistance. This circuit performs the same task of regulating current, but uses a single junction field-effect transistor (JFET) instead of two BJTs.

The two series resistors R_{adjust} and R_{limit} set the current regulation point, while the load resistors and the test points between them serve only to demonstrate constant current despite changes in load resistance.

To begin the experiment, touch the test probe to TP4 and adjust the potentiometer through its range of travel. You should see a small, changing current indicated by your ammeter as you move the potentiometer mechanism: no more than a few milliamps. Leave the potentiometer set to a position giving a round number of milliamps and move the meter's black test probe to TP3. The current indication should be very nearly the same as before. Move the probe to TP2, then TP1. Again, you should see a nearly unchanged amount of current. Try adjusting the potentiometer to another position, giving a different current indication, and touch the meter's black probe to test points TP1 through TP4, noting the stability of the current indications as you change load resistance. This demonstrates the current *regulating* behavior of this circuit.

TP5, at the end of a 10 k Ω resistor, is provided for introducing a large change in load resistance. Connecting the black test probe of your ammeter to that test point gives a combined load resistance of 14.5 k Ω , which will be too much resistance for the transistor to maintain maximum regulated current through. To experience what I'm describing here, touch the black test probe to TP1 and adjust the potentiometer for maximum current. Now, move the black test probe to TP2, then TP3, then TP4. For all these test point positions, the current will remain approximately constant. However, when you touch the black probe to TP5, the current will fall dramatically. Why? Because at this level of load resistance, there is insufficient voltage drop across the transistor to maintain regulation. In other words, the transistor will be saturated as it attempts to provide more current than the circuit resistance will allow.

Move the black test probe back to TP1 and adjust the potentiometer for minimum current. Now, touch the black test probe to TP2, then TP3, then TP4, and finally TP5. What do you notice about the current indication at all these points? When the current regulation point is adjusted to a lesser value, the transistor is able to maintain regulation over a much larger range of load resistance.

An important caveat with the BJT current mirror circuit is that both transistors must be at equal temperature for the two currents to be equal. With this circuit, however, transistor temperature is almost irrelevant. Try grasping the transistor between your fingers to heat it up, noting the load current with your ammeter. Try cooling it down afterward by blowing on it. Not only is the requirement of transistor matching eliminated (due to the use of just *one* transistor), but the thermal effects are all but eliminated as well due to the relative thermal immunity of the field-effect transistor. This behavior also makes field-effect transistors immune to thermal runaway; a decided advantage over bipolar junction transistors.

An interesting application of this current-regulator circuit is the so-called *constant-current diode*. Described in the "Diodes and Rectifiers" chapter of volume III, this diode isn't really a PN junction device at all. Instead, it is a JFET with a fixed resistance connected between the gate and source terminals:

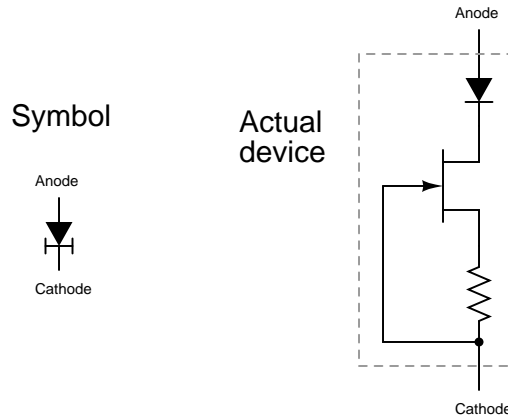
Constant-current diode

A normal PN-junction diode is included in series with the JFET to protect the transistor against damage from reverse-bias voltage, but otherwise the current-regulating facility of this device is entirely provided by the field-effect transistor.

COMPUTER SIMULATION

Schematic with SPICE node numbers:

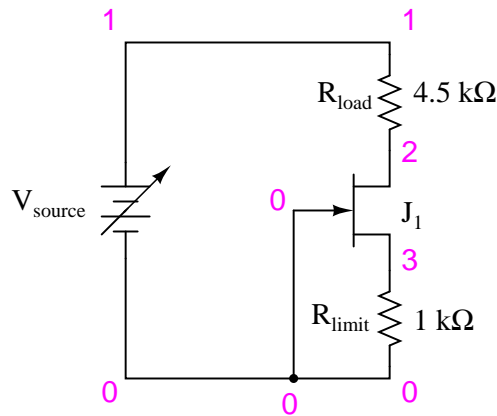

Netlist (make a text file containing the following text, verbatim):

```
JFET current regulator
vsource 1 0
rload 1 2 4.5k
j1 2 0 3 mod1
rlimit 3 0 1k
.model mod1 njf
.dc vsource 6 12 0.1
.plot dc i(vsource)
```

```
.end
```

SPICE does not allow for "sweeping" resistance values, so to demonstrate the current regulation of this circuit over a wide range of conditions, I've elected to sweep the source voltage from 6 to 12 volts in 0.1 volt steps. If you wish, you can set `rload` to different resistance values and verify that the circuit current remains constant. With an `rlimit` value of 1 k Ω , the regulated current will be 291.8 μA . This current figure will most likely *not* be the same as your actual circuit current, due to differences in JFET parameters.

Many manufacturers give SPICE model parameters for their transistors, which may be typed in the `.model` line of the netlist for a more accurate circuit simulation.

5.16 Differential amplifier

PARTS AND MATERIALS

- Two 6-volt batteries
- Two NPN transistors – models 2N2222 or 2N3403 recommended (Radio Shack catalog # 276-1617 is a package of fifteen NPN transistors ideal for this and other experiments)
- Two 10 k Ω potentiometers, single-turn, linear taper (Radio Shack catalog # 271-1715)
- Two 22 k Ω resistors
- Two 10 k Ω resistors
- One 100 k Ω resistor
- One 1.5 k Ω resistor

Resistor values are not especially critical in this experiment, but have been chosen to provide high voltage gain for a "comparator-like" differential amplifier behavior.

CROSS-REFERENCES

Lessons In Electric Circuits, Volume 3, chapter 4: "Bipolar Junction Transistors"

Lessons In Electric Circuits, Volume 3, chapter 8: "Operational Amplifiers"

LEARNING OBJECTIVES

- Basic design of a differential amplifier circuit.
- Working definitions of *differential* and *common-mode* voltages

SCHEMATIC DIAGRAM

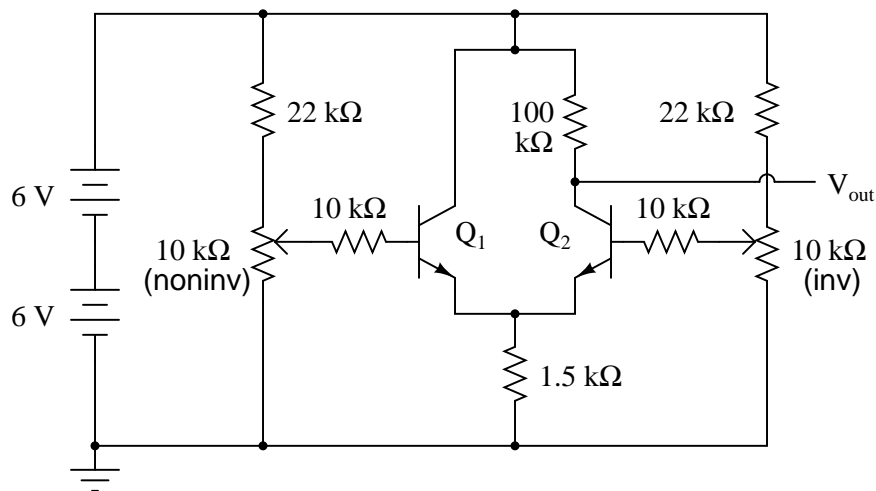

ILLUSTRATION

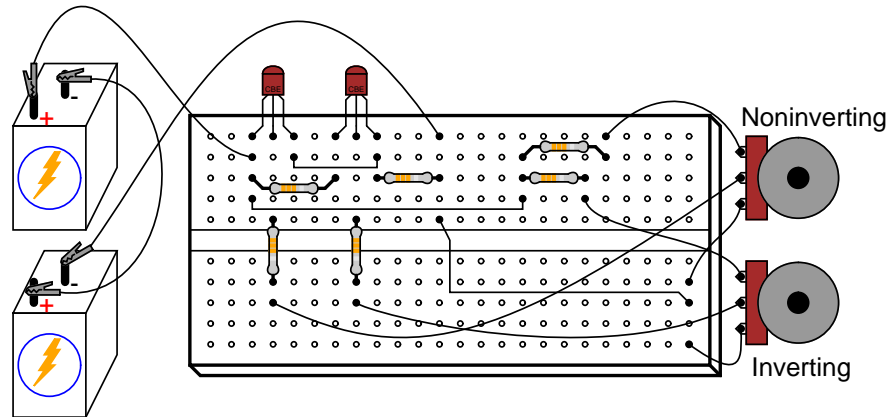

INSTRUCTIONS

This circuit forms the heart of most operational amplifier circuits: the *differential pair*. In the form shown here, it is a rather crude differential amplifier, quite nonlinear and unsymmetrical with regard to output voltage versus input voltage(s). With a high voltage gain created by a large collector/emitter resistor ratio ($100\text{ k}\Omega/1.5\text{ k}\Omega$), though, it acts primarily as a comparator: the output voltage rapidly changing value as the two input voltage signals approach equality.

Measure the output voltage (voltage at the collector of Q_2 with respect to ground) as the input voltages are varied. Note how the two potentiometers have different effects on the output voltage: one input tends to drive the output voltage in the same direction (noninverting), while the other tends to drive the output voltage in the opposite direction (inverting). This is the essential nature of a *differential amplifier*: two complementary inputs, with contrary effects on the output signal. Ideally, the output voltage of such an amplifier is strictly a function of the *difference* between the two input signals. This circuit falls considerably short of the ideal, as even a cursory test will reveal.

An ideal differential amplifier ignores all *common-mode voltage*, which is whatever level of voltage common to both inputs. For example, if the inverting input is at 3 volts and the noninverting input at 2.5 volts, the differential voltage will be 0.5 volts ($3 - 2.5$) but the common-mode voltage will be 2.5 volts, since that is the lowest input signal level. Ideally, this condition should produce the same output signal voltage as if the inputs were set at 3.5 and 3 volts, respectively (0.5 volts differential, with a 3 volt common-mode voltage). However, this circuit does *not* give the same result for the two different input signal scenarios. In other words, its output voltage depends on both the differential voltage *and* the common-mode voltage.

As imperfect as this differential amplifier is, its behavior could be worse. Note how the input signal potentiometers have been limited by $22\text{ k}\Omega$ resistors to an adjustable range of approximately 0 to 4 volts, given a power supply voltage of 12 volts. If you'd like to see how this circuit behaves without any input signal limiting, just bypass the $22\text{ k}\Omega$ resistors with jumper wires, allowing full 0 to 12 volt adjustment range from each potentiometer.

Do not worry about building up excessive heat while adjusting potentiometers in this circuit! Unlike the current mirror circuit, this circuit is protected from thermal runaway by the

emitter resistor ($1.5 \text{ k}\Omega$), which doesn't allow enough transistor current to cause any problem.

5.17 Simple op-amp

PARTS AND MATERIALS

- Two 6-volt batteries
- Four NPN transistors – models 2N2222 or 2N3403 recommended (Radio Shack catalog # 276-1617 is a package of fifteen NPN transistors ideal for this and other experiments)
- Two PNP transistors – models 2N2907 or 2N3906 recommended (Radio Shack catalog # 276-1604 is a package of fifteen PNP transistors ideal for this and other experiments)
- Two 10 k Ω potentiometers, single-turn, linear taper (Radio Shack catalog # 271-1715)
- One 270 k Ω resistor
- Three 100 k Ω resistors
- One 10 k Ω resistor

CROSS-REFERENCES

Lessons In Electric Circuits, Volume 3, chapter 4: "Bipolar Junction Transistors"

Lessons In Electric Circuits, Volume 3, chapter 8: "Operational Amplifiers"

LEARNING OBJECTIVES

- Design of a differential amplifier circuit using current mirrors.
- Effects of negative feedback on a high-gain differential amplifier.

SCHEMATIC DIAGRAM

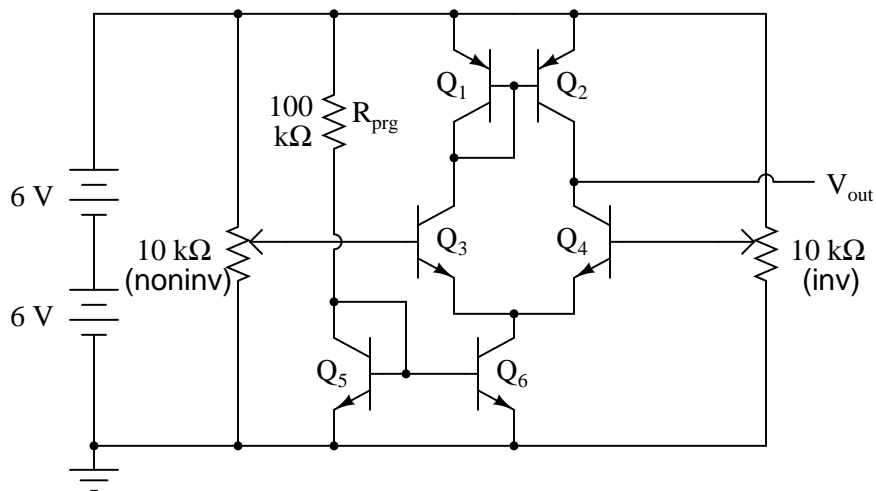

ILLUSTRATION

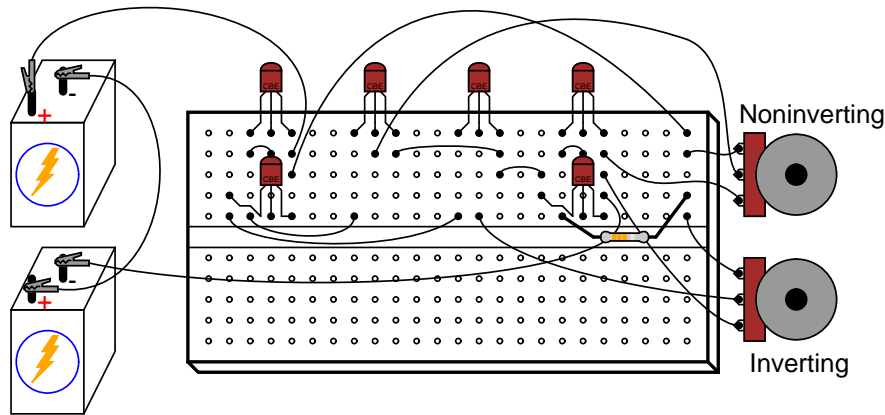

INSTRUCTIONS

This circuit design improves on the differential amplifier shown previously. Rather than use resistors to drop voltage in the differential pair circuit, a set of current mirrors is used instead, the result being higher voltage gain and more predictable performance. With a higher voltage gain, this circuit is able to function as a working operational amplifier, or *op-amp*. Op-amps form the basis of a great many modern analog semiconductor circuits, so understanding the internal workings of an operational amplifier is important.

PNP transistors Q_1 and Q_2 form a current mirror which tries to keep current split equally through the two differential pair transistors Q_3 and Q_4 . NPN transistors Q_5 and Q_6 form another current mirror, setting the *total* differential pair current at a level predetermined by resistor R_{prg} .

Measure the output voltage (voltage at the collector of Q_4 with respect to ground) as the input voltages are varied. Note how the two potentiometers have different effects on the output voltage: one input tends to drive the output voltage in the same direction (noninverting), while the other tends to drive the output voltage in the opposite direction (inverting). You will notice that the output voltage is most responsive to changes in the input when the two input signals are nearly equal to each other.

Once the circuit's differential response has been proven (the output voltage sharply transitioning from one extreme level to another when one input is adjusted above and below the other input's voltage level), you are ready to use this circuit as a real op-amp. A simple op-amp circuit called a *voltage follower* is a good configuration to try first. To make a voltage follower circuit, directly connect the output of the amplifier to its inverting input. This means connecting the collector and base terminals of Q_4 together, and discarding the "inverting" potentiometer:

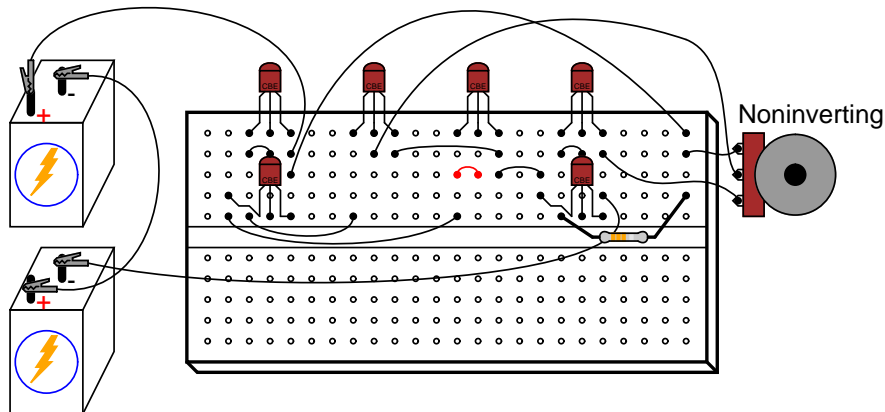
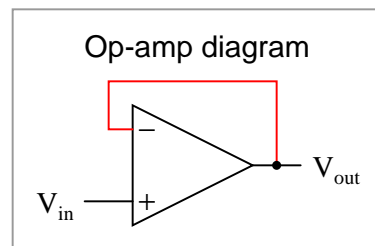
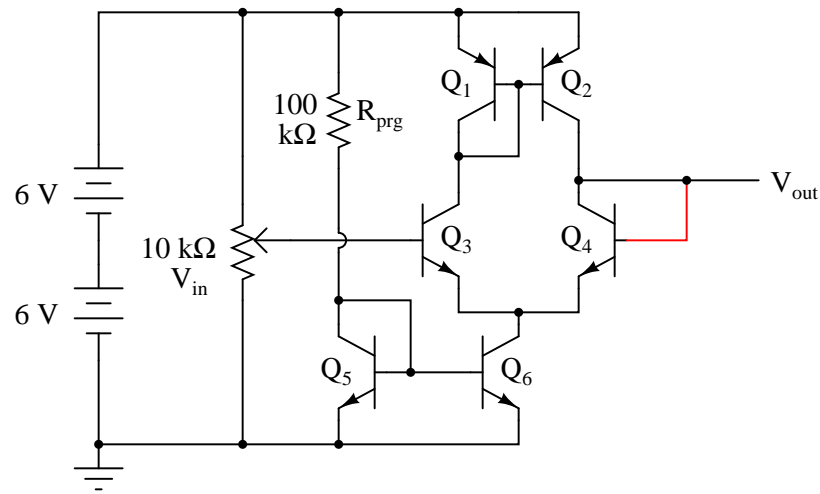

Note the triangular symbol of the op-amp shown in the lower schematic diagram. The inverting and noninverting inputs are designated with (-) and (+) symbols, respectively, with the output terminal at the right apex. The feedback wire connecting output to inverting input is shown in red in the above diagrams.

As a voltage follower, the output voltage should "follow" the input voltage very closely, deviating no more than a few hundredths of a volt. This is a much more precise follower circuit than that of a single common-collector transistor, described in an earlier experiment!

A more complex op-amp circuit is called the *noninverting amplifier*, and it uses a pair of resistors in the feedback loop to "feed back" a fraction of the output voltage to the inverting input, causing the amplifier to output a voltage equal to some multiple of the voltage at the noninverting input. If we use two equal-value resistors, the feedback voltage will be 1/2 the output voltage, causing the output voltage to become twice the voltage impressed at the noninverting input. Thus, we have a voltage amplifier with a precise gain of 2:

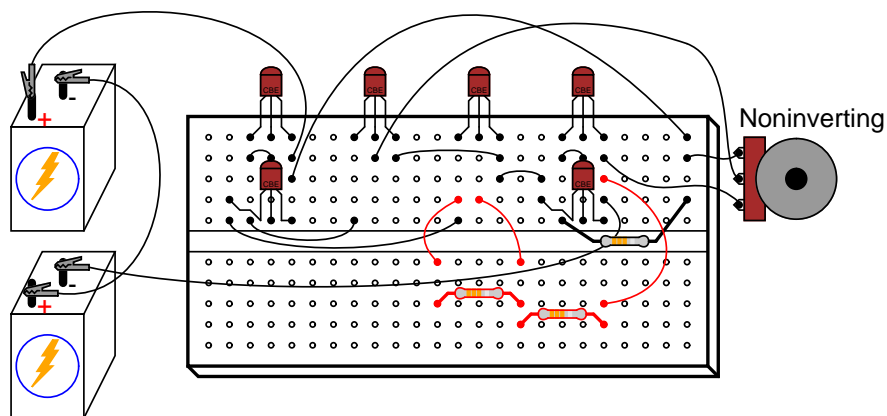
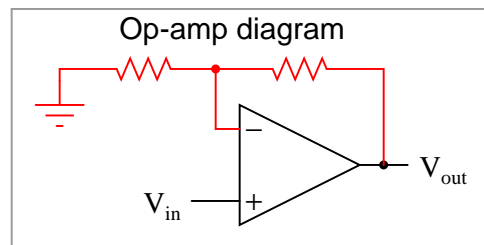
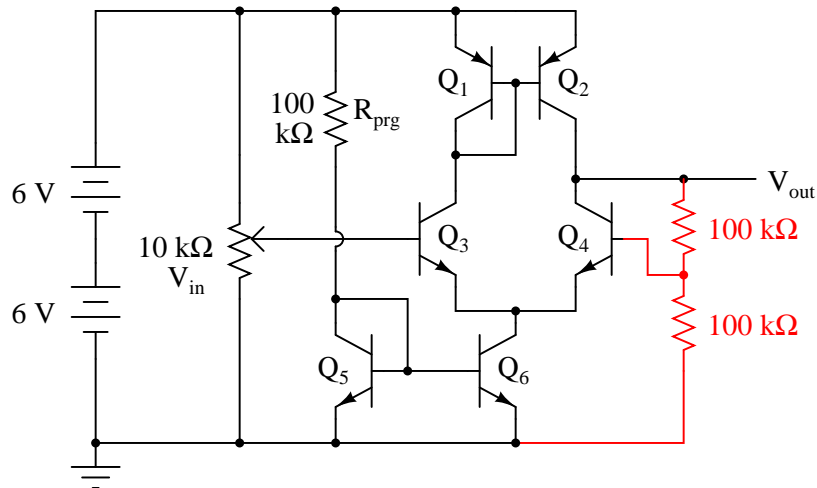

As you test this noninverting amplifier circuit, you may notice slight discrepancies between the output and input voltages. According to the feedback resistor values, the voltage gain should be exactly 2. However, you may notice deviations in the order of several hundredths of a volt between what the output voltage is and what it should be. These deviations are due to imperfections of the differential amplifier circuit, and may be greatly diminished if we add more amplification stages to increase the differential voltage gain. However, one way we can maximize the precision of the existing circuit is to change the resistance of R_{prg} . This resistor sets the lower current mirror's control point, and in so doing influences many performance parameters of the op-amp. Try substituting difference resistance values, ranging from 10 k Ω to 1 M Ω . Do not use a resistance less than 10 k Ω , or else the current mirror transistors may begin to overheat and thermally "run away."

Some operational amplifiers available in prepackaged units provide a way for the user to similarly "program" the differential pair's current mirror, and are called *programmable* op-amps. Most op-amps are not programmable, and have their internal current mirror control points fixed by an internal resistance, trimmed to precise value at the factory.

5.18 Audio oscillator

PARTS AND MATERIALS

- Two 6-volt batteries
- Three NPN transistors – models 2N2222 or 2N3403 recommended (Radio Shack catalog # 276-1617 is a package of fifteen NPN transistors ideal for this and other experiments)
- Two $0.1 \mu\text{F}$ capacitors (Radio Shack catalog # 272-135 or equivalent)
- One $1 \text{ M}\Omega$ resistor
- Two $100 \text{ k}\Omega$ resistors
- One $1 \text{ k}\Omega$ resistor
- Assortment of resistor pairs, less than $100 \text{ k}\Omega$ (ex: two $10 \text{ k}\Omega$, two $5 \text{ k}\Omega$, two $1 \text{ k}\Omega$)
- One light-emitting diode (Radio Shack catalog # 276-026 or equivalent)
- Audio detector with headphones

CROSS-REFERENCES

Lessons In Electric Circuits, Volume 3, chapter 4: "Bipolar Junction Transistors"

Lessons In Electric Circuits, Volume 4, chapter 10: "Multivibrators"

LEARNING OBJECTIVES

- How to build an astable multivibrator circuit using discrete transistors

SCHEMATIC DIAGRAM

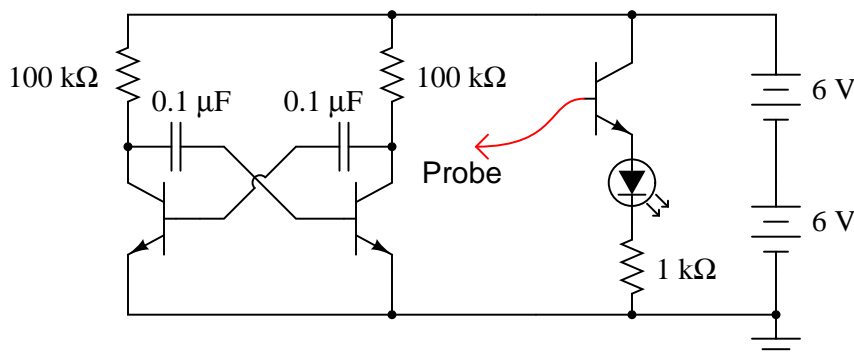

ILLUSTRATION

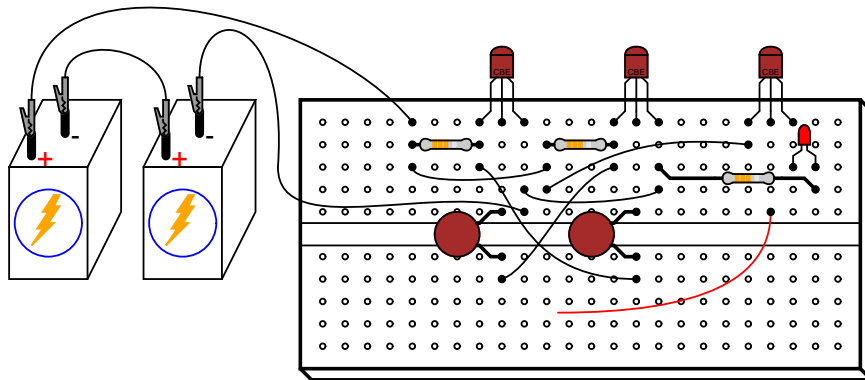

INSTRUCTIONS

The proper name for this circuit is "astable multivibrator". It is a simple, free-running oscillator circuit timed by the sizes of the resistors, capacitors, and power supply voltage. Unfortunately, its output waveform is very distorted, neither sine wave nor square. For the simple purpose of making an audio tone, however, distortion doesn't matter much.

With a 12 volt supply, 100 k Ω resistors, and 0.1 μ F capacitors, the oscillation frequency will be in the low audio range. You may listen to this signal with the audio detector connected with one test probe to ground and the other to one of the transistor's collector terminals. I recommend placing a 1 M Ω resistor in series with the audio detector to minimize both circuit loading effects and headphone loudness:

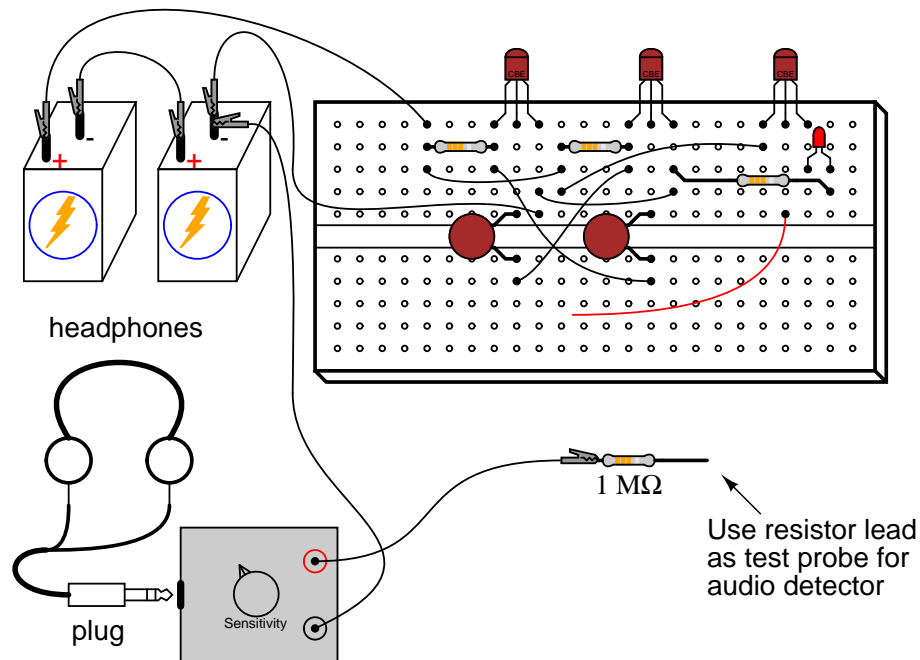

The multivibrator itself is just two transistors, two resistors, and two cross-connecting capacitors. The third transistor shown in the schematic and illustration is there for driving the LED, to be used as a visual indicator of oscillator action. Use the probe wire connected to the base of this common-emitter amplifier to detect voltage at different parts of the circuit with respect to ground. Given the low oscillating frequency of this multivibrator circuit, you should be able to see the LED blink rapidly with the probe wire connected to the collector terminal of either multivibrator transistor.

You may notice that the LED fails to blink with its probe wire touching the *base* of either multivibrator transistor, yet the audio detector tells you there is an oscillating voltage there. Why is this? The LED's common-collector transistor amplifier is a voltage follower, meaning that it doesn't amplify voltage. Thus, if the voltage under test is less than the minimum required by the LED to light up, it will not glow. Since the forward-biased base-emitter junction of an active transistor drops only about 0.7 volts, there is insufficient voltage at either transistor base to energize the LED. The audio detector, being extraordinarily sensitive, though, detects this low voltage signal easily.

Feel free to substitute lower-value resistors in place of the two 100 k Ω units shown. What happens to the oscillation frequency when you do so? I recommend using resistors at least 1 k Ω in size to prevent excessive transistor current.

One shortcoming of many oscillator circuits is its dependence on a minimum amount of power supply voltage. Too little voltage and the circuit ceases to oscillate. This circuit is no exception. You might want to experiment with lower supply voltages and determine the minimum voltage necessary for oscillation, as well as experience the effect supply voltage change has on oscillation frequency.

One shortcoming specific to this circuit is the dependence on mismatched components for successful starting. In order for the circuit to begin oscillating, one transistor must turn on before the other one. Usually, there is enough mismatch in the various component values to enable this to happen, but it is possible for the circuit to "freeze" and fail to oscillate at power-up. If this happens, try different components (same values, but different units) in the circuit.

5.19 Vacuum tube audio amplifier

PARTS AND MATERIALS

- One 12AX7 dual triode vacuum tube
- Two power transformers, 120VAC step-down to 12VAC (Radio Shack catalog # 273-1365, 273-1352, or 273-1511).
- Bridge rectifier module (Radio Shack catalog # 276-1173)
- Electrolytic capacitor, at least 47 μF , with a working voltage of at least 200 volts DC.
- Automotive ignition coil
- Audio speaker, 8 Ω impedance
- Two 100 k Ω resistors
- One 0.1 μF capacitor, 250 WVDC (Radio Shack catalog # 272-1053)
- "Low-voltage AC power supply" as shown in AC Experiments chapter
- One toggle switch, SPST ("Single-Pole, Single-Throw")
- Radio, tape player, musical keyboard, or other source of audio voltage signal

Where can you obtain a 12AX7 tube, you ask? These tubes are very popular for use in the "preamplifier" stages of many professional electric guitar amplifiers. Go to any good music store and you will find them available for a modest price (\$12 US or less). A Russian manufacturer named Sovtek makes these tubes new, so you need not rely on "New-Old-Stock" (NOS) components left over from defunct American manufacturers. This model of tube was very popular in its day, and may be found in old "tubed" electronic test equipment (oscilloscopes, oscillators), if you happen to have access to such equipment. However, I strongly suggest buying a tube new rather than taking chances with tubes salvaged from antique equipment.

It is important to select an electrolytic capacitor with sufficient working voltage (WVDC) to withstand the output of this amplifier's power supply circuit (about 170 volts). I strongly recommend choosing a capacitor with a voltage rating well in excess of the expected operating voltage, so as to handle unexpected voltage surges or any other event that may tax the capacitor. I purchased the Radio Shack electrolytic capacitor assortment (catalog # 272-802), and it happened to contain two 47 μF , 250 WVDC capacitors. If you are not as fortunate, you may build this circuit using five capacitors, each rated at 50 WVDC, to substitute for one 250 WVDC unit:

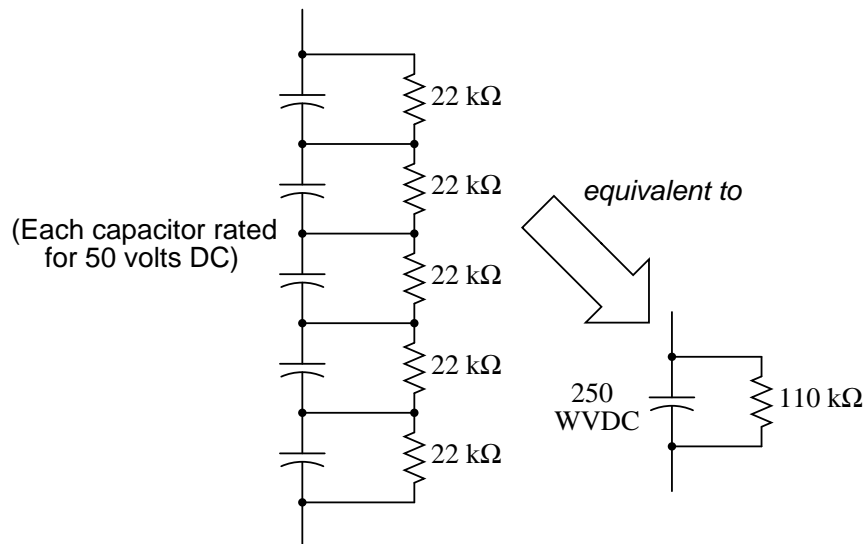

Bear in mind that the total capacitance for this five-capacitor network will be $1/5$, or 20%, of each capacitor's value. Also, to ensure even charging of capacitors in the network, be sure all capacitor values (in μF) and all resistor values are identical.

An *automotive ignition coil* is a special-purpose high-voltage transformer used in car engines to produce tens of thousands of volts to "fire" the spark plugs. In this experiment, it is used (very unconventionally, I might add!) as an impedance-matching transformer between the vacuum tube and an $8\ \Omega$ audio speaker. The specific choice of "coil" is not critical, so long as it is in good operating condition. Here is a photograph of the coil I used for this experiment:



The audio speaker need not be extravagant. I've used small "bookshelf" speakers, automotive (6"x9") speakers, as well as a large (100 watt) 3-way stereo speaker for this experiment,

and they all work fine. **Do not use a set of headphones** under any circumstances, as the ignition coil does not provide electrical isolation between the 170 volts DC of the "plate" power supply and the speaker, thus elevating the speaker connections to that voltage with respect to ground. Since obviously placing wires on your head with high voltage to ground would be *very hazardous*, please do not use headphones!

You will need some source of audio-frequency AC as an input signal to this amplifier circuit. I recommend a small battery-powered radio or musical keyboard, with an appropriate cable plugged into the "headphone" or "audio out" jack to convey the signal to your amplifier.

CROSS-REFERENCES

Lessons In Electric Circuits, Volume 3, chapter 13: "Electron Tubes"

Lessons In Electric Circuits, Volume 3, chapter 3: "Diodes and Rectifiers"

Lessons In Electric Circuits, Volume 2, chapter 9: "Transformers"

LEARNING OBJECTIVES

- Using a vacuum tube (triode) as an audio amplifier
- Using transformers in both step-down and step-up operation
- How to build a high-voltage DC power supply
- Using a transformer to match impedances

SCHEMATIC DIAGRAM

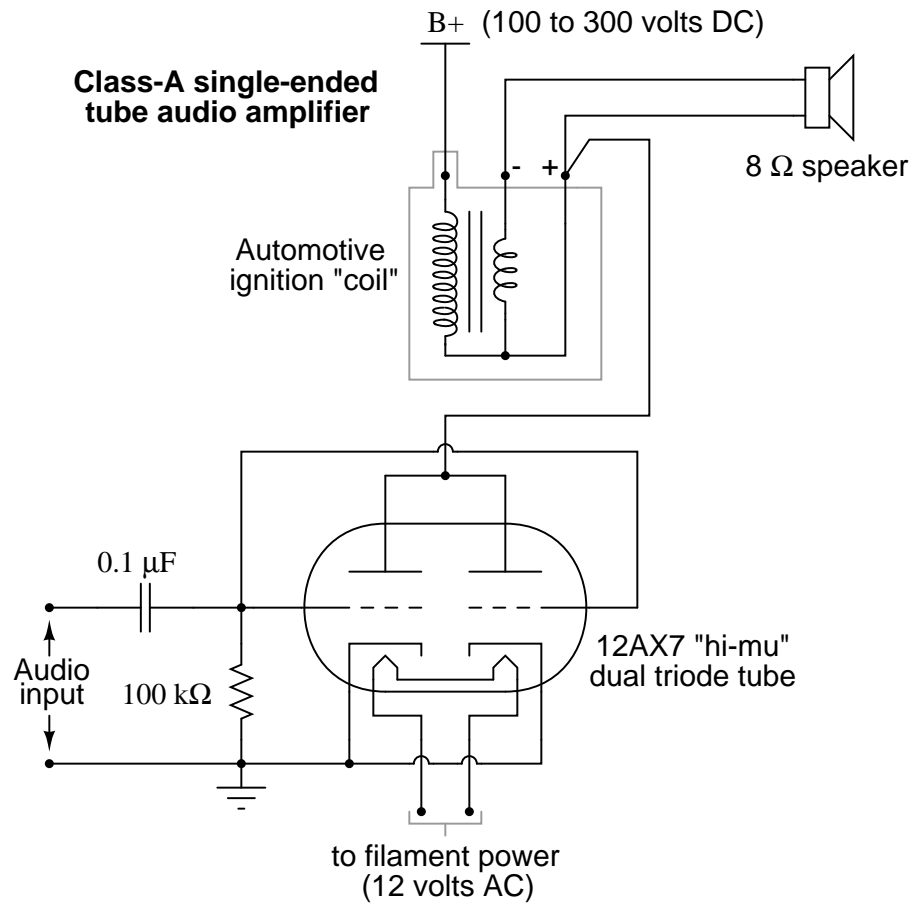

High-voltage "plate" DC power supply

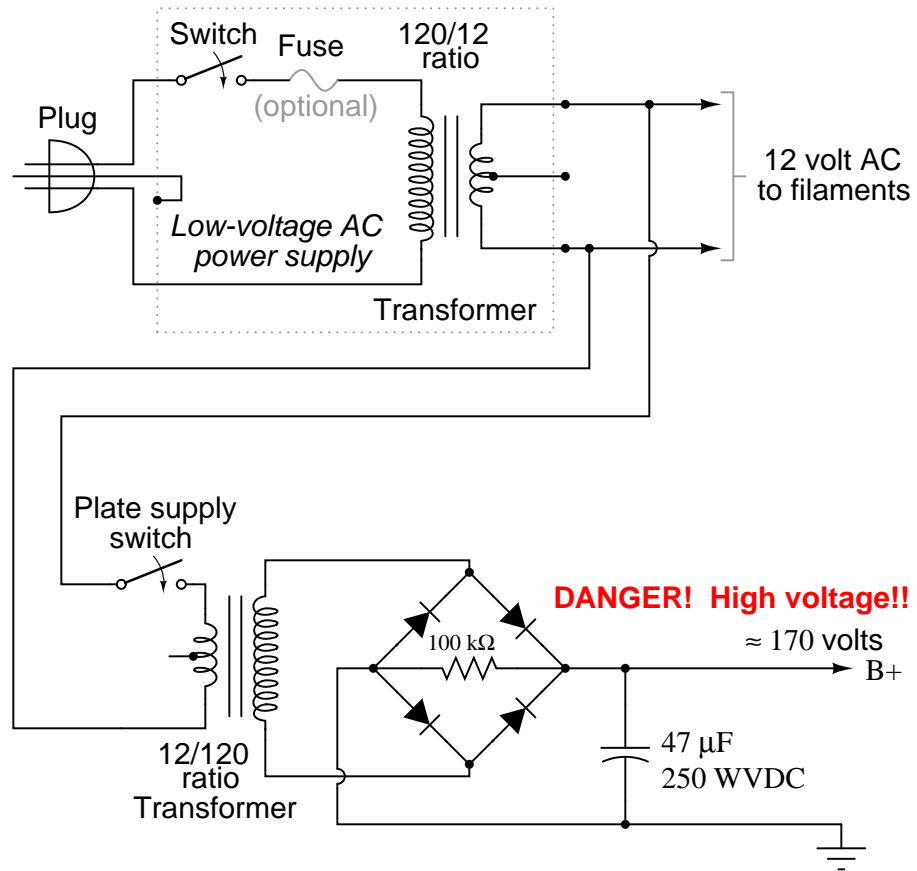

ILLUSTRATION

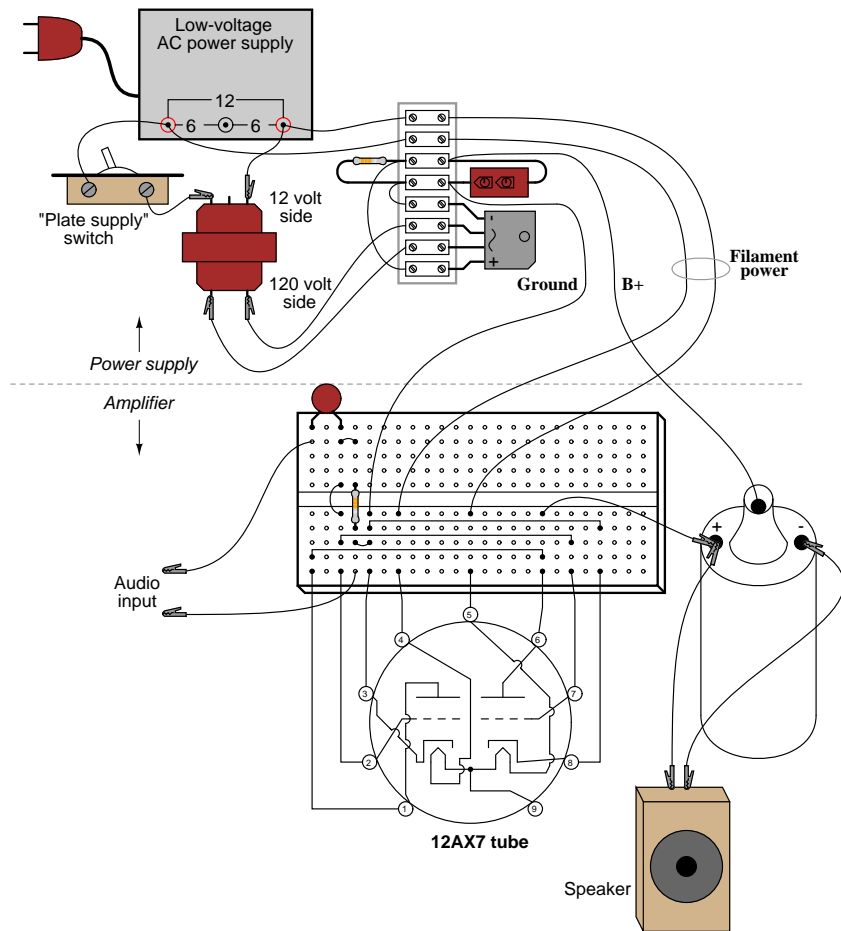

INSTRUCTIONS

Welcome to the world of vacuum tube electronics! While not exactly an application of semiconductor technology (power supply rectifier excepted), this circuit is useful as an introduction to vacuum tube technology, and an interesting application for impedance-matching transformers. It should be noted that **building and operating this circuit involves work with lethal voltages!** You must exhibit the utmost care while working with this circuit, as 170 volts DC is capable of electrocuting you!! It is recommended that beginners seek qualified assistance (experienced electricians, electronics technicians, or engineers) if attempting to build this amplifier.

WARNING: do not touch any wires or terminals while the amplifier circuit is energized! If you must make contact with the circuit at any point, turn off the "plate" power supply switch and wait for the filter capacitor to discharge below 30 volts before touching any part of the circuit. If testing circuit voltages with the power on, use only one hand if possible to avoid the possibility of an arm-to-arm electric shock.

Building the high-voltage power supply

Vacuum tubes require fairly high DC voltage applied between plate and cathode terminals in order to function efficiently. Although it is possible to operate the amplifier circuit described in this experiment on as low as 24 volts DC, the power output will be miniscule and the sound quality poor. The 12AX7 triode is rated at a maximum "plate voltage" (voltage applied between plate and cathode terminals) of 330 volts, so our power supply of 170 volts DC specified here is well within that maximum limit. I've operated this amplifier on as high as 235 volts DC, and discovered that both sound quality and intensity improved *slightly*, but not enough in my estimation to warrant the additional hazard to experimenters.

The power supply actually has two different power outputs: the "B+" DC output for plate power, and the "filament" power, which is only 12 volts AC. Tubes require power applied to a small filament (sometimes called a *heater*) in order to function, as the cathode must be hot enough to thermally emit electrons, and that doesn't happen at room temperature! Using one power transformer to step household 120 volt AC power down to 12 volts AC provides low-voltage for the filaments, and another transformer connected in step-up fashion brings the voltage back up to 120 volts. You might be wondering, "why step the voltage back up to 120 volts with another transformer? Why not just tap off the wall socket plug to obtain 120 volt AC power *directly*, and then rectify that into 170 volts DC?" The answer to this is twofold: first, running power through two transformers inherently limits the amount of current that may be sent into an accidental short-circuit on the plate-side of the amplifier circuit. Second, it electrically isolates the plate circuit from the wiring system of your house. If we were to rectify wall-socket power with a diode bridge, it would make both DC terminals (+ and -) elevated in voltage from the safety ground connection of your house's electrical system, thereby increasing the shock hazard.

Note the toggle switch connected between the 12-volt windings of the two transformers, labeled "Plate supply switch." This switch controls power to the step-up transformer, thereby controlling plate voltage to the amplifier circuit. Why not just use the main power switch connected to the 120 volt plug? Why have a second switch to shut off the DC high voltage, when shutting off one main switch would accomplish the same thing? The answer lies in proper vacuum tube operation: like incandescent light bulbs, vacuum tubes "wear" when their filaments are powered up and down repeatedly, so having this additional switch in the circuit allows you to shut off the DC high voltage (for safety when modifying or adjusting the circuit) without having to shut off the filament. Also, it is a good habit to wait for the tube to reach full operating temperature *before* applying plate voltage, and this second switch allows you to delay the application of plate voltage until the tube has had time to reach operating temperature.

During operation, you should have a voltmeter connected to the "B+" output of the power supply (between the B+ terminal and ground), continuously providing indication of the power supply voltage. This meter will show you when the filter capacitor has discharged below the shock-hazard limit (30 volts) when you turn off the "Plate supply switch" to service the amplifier circuit.

The "ground" terminal shown on the DC output of the power supply circuit need not connect to earth ground. Rather, it is merely a symbol showing a common connection with a corresponding ground terminal symbol in the amplifier circuit. In the circuit you build, there will be a piece of wire connecting these two "ground" points together. As always, the designation of certain common points in a circuit by means of a shared symbol is standard practice in electronic schematics.

You will note that the schematic diagram shows a 100 k Ω resistor in parallel with the filter capacitor. This resistor is quite necessary, as it provides the capacitor a path for discharge when the AC power is turned off. Without this "bleeder" resistor in the circuit, the capacitor would likely retain a dangerous charge for a long time after "power-down," posing an additional shock hazard to you. In the circuit I built – with a 47 μ F capacitor and a 100 k Ω bleeder resistor – the time constant of this RC circuit was a brief 4.7 seconds. If you happen to find a larger filter capacitor value (good for minimizing unwanted power supply "hum" in the speaker), you will need to use a correspondingly smaller value of bleeder resistor, or wait longer for the voltage to bleed off each time you turn the "Plate supply" switch off.

Be sure you have the power supply safely constructed and working reliably before attempting to power the amplifier circuit with it. This is good circuit-building practice in general: build and troubleshoot the power supply first, then build the circuit you intend to power with it. If the power supply does not function as it should, then neither will the powered circuit, no matter how well it may be designed and built.

Building the amplifier

One of the problems with building vacuum tube circuits in the 21st century is that *sockets* for these components can be difficult to find. Given the limited lifetime of most "receiver" tubes (a few years), most "tubed" electronic devices used sockets for mounting the tubes, so that they could be easily removed and replaced. Though tubes may still be obtained (from music supply stores) with relative ease, the sockets they plug into are considerably scarcer – your local Radio Shack will not have them in stock! How, then, do we build circuits with tubes, if we might not be able to obtain sockets for them to plug in to?

For small tubes, this problem may be circumvented by directly soldering short lengths of 22-gauge solid copper wire to the pins of the tube, thus enabling you to "plug" the tube into a solderless breadboard. Here is a photograph of my tube amplifier, showing the 12AX7 in an inverted position (pin-side-up). Please disregard the 10-segment LED bargraph to the left and the 8-position DIP switch assembly to the right in the photograph, as these are leftover components from a digital circuit experiment assembled previously on my breadboard.

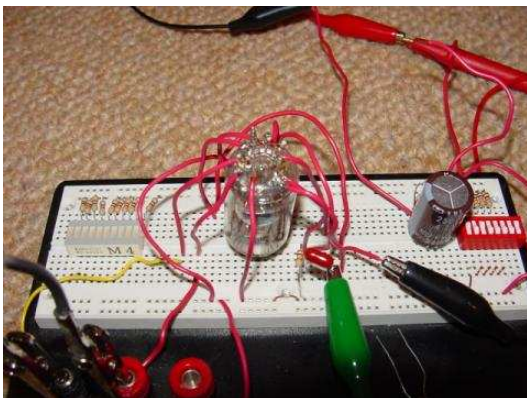

One benefit of mounting the tube in this position is ease of pin identification, since most "pin connection diagrams" for tubes are shown from a bottom view:

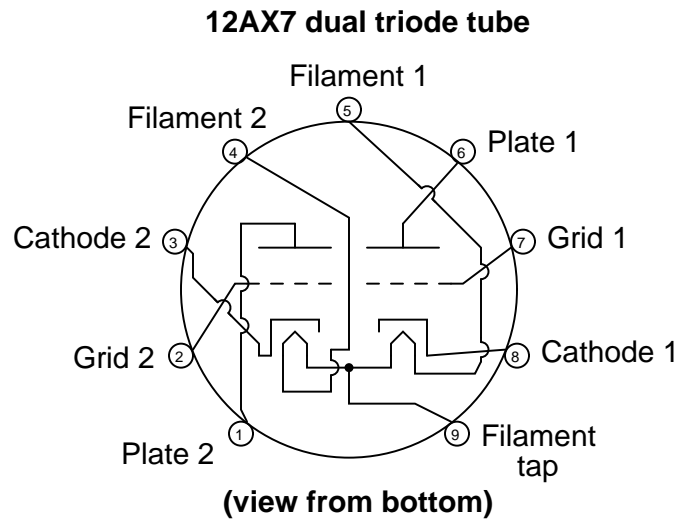

You will notice on the amplifier schematic that both triode elements inside the 12AX7's glass envelope are being used, in parallel: plate connected to plate, grid connected to grid, and cathode connected to cathode. This is done to maximize power output from the tube, but it is not necessary for demonstrating basic operation. You may use just one of the triodes, for simplicity, if you wish.

The $0.1 \mu\text{F}$ capacitor shown on the schematic "couples" the audio signal source (radio, musical keyboard, etc.) to the tube's grid(s), allowing AC to pass but blocking DC. The $100 \text{ k}\Omega$ resistor ensures that the average DC voltage between grid and cathode is zero, and cannot "float" to some high level. Typically, bias circuits are used to keep the grid slightly negative with respect to ground, but for this purpose a bias circuit would introduce more complexity than its worth.

When I tested my amplifier circuit, I used the output of a radio receiver, and later the output of a compact disk (CD) player, as the audio signal source. Using a "mono"-to-"phono" connector extension cord plugged into the headphone jack of the receiver/CD player, and alligator clip jumper wires connecting the "mono" tip of the cord to the input terminals of the tube amplifier, I was able to easily send the amplifier audio signals of varying amplitude to test its performance over a wide range of conditions:

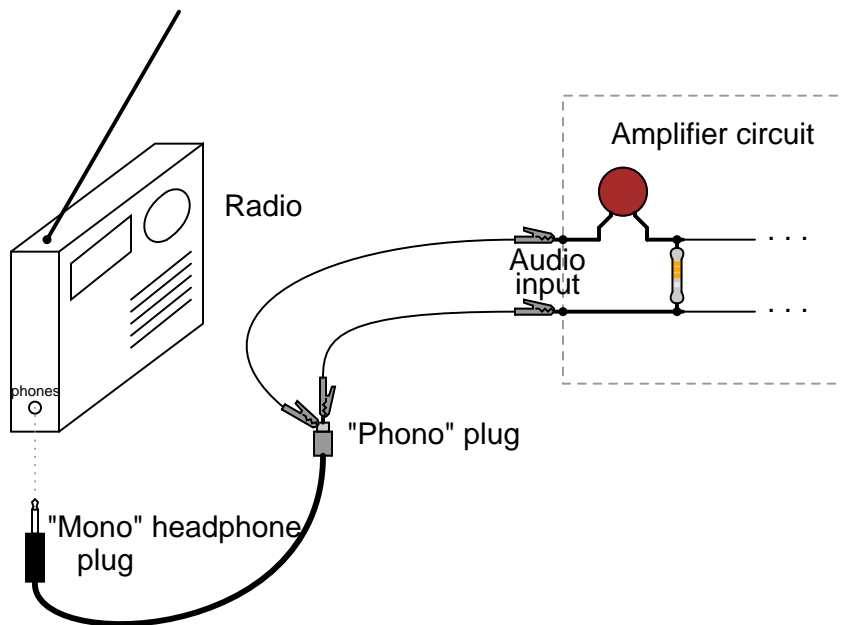

A transformer is essential at the output of the amplifier circuit for "matching" the impedances of vacuum tube and speaker. Since the vacuum tube is a high-voltage, low-current device, and most speakers are low-voltage, high-current devices, the mismatch between them would result in very audio low power output if they were directly connected. To successfully match the high-voltage, low-current source to the low-voltage, high current load, we must use a step-down transformer.

Since the vacuum tube circuit's Thevenin resistance ranges in the tens of thousands of ohms, and the speaker only has about 8 ohms impedance, we will need a transformer with an impedance ratio of about 10,000:1. Since the impedance ratio of a transformer is the *square* of its turns ratio (or voltage ratio), we're looking for a transformer with a turns ratio of about 100:1. A typical automotive ignition coil has approximately this turns ratio, and it is also rated for extremely high voltage on the high-voltage winding, making it well suited for this application.

The only bad aspect of using an ignition coil is that it provides no electrical isolation between primary and secondary windings, since the device is actually an autotransformer, with each winding sharing a common terminal at one end. This means that the speaker wires will be at a high DC voltage with respect to circuit ground. So long as we know this, and avoid touching those wires during operation, there will be no problem. Ideally, though, the transformer would provide complete isolation as well as impedance matching, and the speaker wires would be perfectly safe to touch during use.

Remember, make all connections in the circuit *with the power turned off!* After checking connections visually and with an ohmmeter to ensure that the circuit is built as per the schematic diagram, apply power to the filaments of the tube and wait about 30 seconds for it to reach operating temperature. The both filaments should emit a soft, orange glow, visible from both the top and bottom views of the tube.

Turn the volume control of your radio/CD player/musical keyboard signal source to minimum, then turn on the plate supply switch. The voltmeter you have connected between the power supply's B+ output terminal and "ground" should register full voltage (about 170 volts). Now, increase the volume control on the signal source and listen to the speaker. If all is well, you should hear the correct sounds clearly through the speaker.

Troubleshooting this circuit is best done with the sensitive audio detector described in the DC and AC chapters of this Experiments volume. Connect a $0.1\ \mu\text{F}$ capacitor in series with each test lead to block DC from the detector, then connect one of the test leads to ground, while using the other test lead to check for audio signal at various points in the circuit. Use capacitors with a high voltage rating, like the one used on the input of the amplifier circuit:

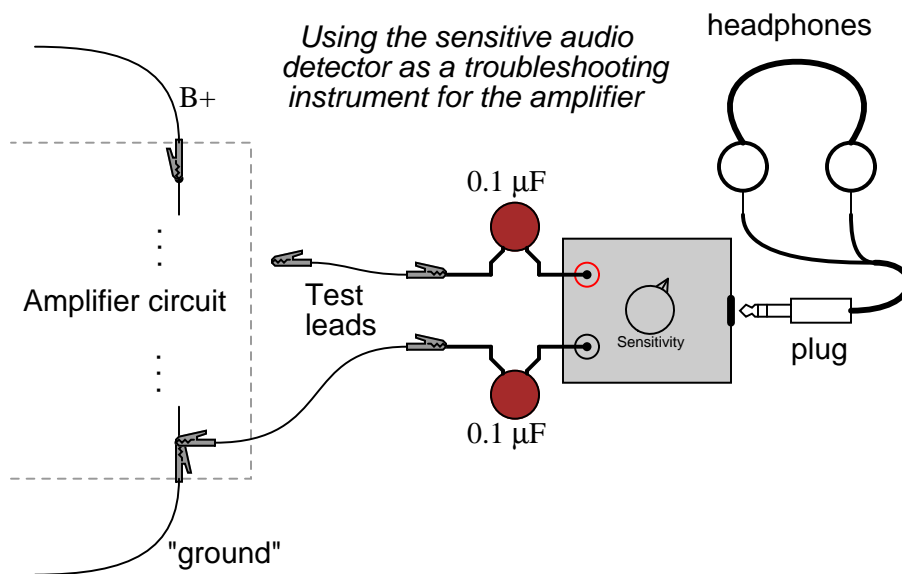

Using two coupling capacitors instead of just one adds an additional degree of safety, in helping to isolate the unit from any (high) DC voltage. Even without the extra capacitor, though, the detector's internal transformer should provide sufficient electrical isolation for your safety in using it to test for signals in a high-voltage circuit like this, especially if you built your detector using a 120 volt power transformer (rather than an "audio output" transformer) as suggested. Use it to test for a good signal at the input, then at the grid pin(s) of the tube, then at the plate of the tube, etc. until the problem is found. Being capacitively coupled, the detector is also able to test for excessive power supply "hum:" touch the free test lead to the supply's B+ terminal and listen for a loud 60 Hz humming noise. The noise should be very soft, not loud. If it is loud, the power supply is not filtered adequately enough, and may need additional filter capacitance.

After testing a point in the amplifier circuit with large DC voltage to ground, the coupling capacitors on the detector may build up substantial voltage. To discharge this voltage, briefly touch the free test lead to the grounded test lead. A "pop" sound should be heard in the headphones as the coupling capacitors discharge.

If you would rather use a voltmeter to test for the presence of audio signal, you may do so, setting it to a sensitive AC voltage range. The indication you get from a voltmeter, though,

doesn't tell you anything about the *quality* of the signal, just its mere presence. Bear in mind that most AC voltmeters will register a transient voltage when initially connected across a source of DC voltage, so don't be surprised to see a "spike" (a strong, momentary voltage indication) at the very moment contact is made with the meter's probes to the circuit, rapidly decreasing to the true AC signal value.

You may be pleasantly surprised at the quality and depth of tone from this little amplifier circuit, especially given its low power output: less than 1 watt of audio power. Of course, the circuit is quite crude and sacrifices quality for simplicity and parts availability, but it serves to demonstrate the basic principle of vacuum tube amplification. Advanced hobbyists and students may wish to experiment with biasing networks, negative feedback, different output transformers, different power supply voltages, and even different tubes, to obtain more power and/or better sound quality.

Here is a photo of a very similar amplifier circuit, built by the husband-and-wife team of Terry and Cheryl Goetz, illustrating what can be done when care and craftsmanship are applied to a project like this.



Bibliography

- [1] Forrest M. Mims III, "Sun Photometer with Light-Emitting Diodes as Spectrally Selective Detectors", *Applied Optics*, 31, 33, 6965-6967, 1992.
- [2] Forrest M. Mims III, "Light Emitting Diodes" Howard W. Sams & Co., 1973, pp. 118-119.
- [3] Forrest M. Mims III, Private communications, February 29, 2008.

Chapter 6

ANALOG INTEGRATED CIRCUITS

Contents

6.1 Introduction	287
6.2 Voltage comparator	289
6.3 Precision voltage follower	292
6.4 Noninverting amplifier	296
6.5 High-impedance voltmeter	299
6.6 Integrator	303
6.7 555 audio oscillator	309
6.8 555 ramp generator	312
6.9 PWM power controller	315
6.10 Class B audio amplifier	319

6.1 Introduction

Analog circuits are circuits dealing with signals free to vary from zero to full power supply voltage. This stands in contrast to *digital* circuits, which almost exclusively employ "all or nothing" signals: voltages restricted to values of zero and full supply voltage, with no valid state in between those extreme limits. Analog circuits are often referred to as *linear* circuits to emphasize the valid continuity of signal range forbidden in digital circuits, but this label is unfortunately misleading. Just because a voltage or current signal is allowed to vary smoothly between the extremes of zero and full power supply limits does not necessarily mean that all mathematical relationships between these signals are linear in the "straight-line" or "proportional" sense of the word. As you will see in this chapter, many so-called "linear" circuits are quite *nonlinear* in their behavior, either by necessity of physics or by design.

The circuits in this chapter make use of *IC*, or *integrated circuit*, components. Such components are actually networks of interconnected components manufactured on a single wafer of semiconducting material. Integrated circuits providing a multitude of pre-engineered functions are available at very low cost, benefitting students, hobbyists and professional circuit designers alike. Most integrated circuits provide the same functionality as "discrete" semiconductor circuits at higher levels of reliability and at a fraction of the cost. Usually, discrete-component circuit construction is favored only when power dissipation levels are too high for integrated circuits to handle.

Perhaps the most versatile and important analog integrated circuit for the student to master is the *operational amplifier*, or *op-amp*. Essentially nothing more than a differential amplifier with very high voltage gain, op-amps are the workhorse of the analog design world. By cleverly applying feedback from the output of an op-amp to one or more of its inputs, a wide variety of behaviors may be obtained from this single device. Many different models of op-amp are available at low cost, but circuits described in this chapter will incorporate only commonly available op-amp models.

6.2 Voltage comparator

PARTS AND MATERIALS

- Operational amplifier, model 1458 or 353 recommended (Radio Shack catalog # 276-038 and 900-6298, respectively)
- Three 6 volt batteries
- Two 10 k Ω potentiometers, linear taper (Radio Shack catalog # 271-1715)
- One light-emitting diode (Radio Shack catalog # 276-026 or equivalent)
- One 330 Ω resistor
- One 470 Ω resistor

This experiment only requires a single operational amplifier. The model 1458 and 353 are both "dual" op-amp units, with two complete amplifier circuits housed in the same 8-pin DIP package. I recommend that you purchase and use "dual" op-amps over "single" op-amps even if a project only requires one, because they are more versatile (the same op-amp unit can function in projects requiring only one amplifier as well as in projects requiring two). In the interest of purchasing and stocking the least number of components for your home laboratory, this makes sense.

CROSS-REFERENCES

Lessons In Electric Circuits, Volume 3, chapter 8: "Operational Amplifiers"

LEARNING OBJECTIVES

- How to use an op-amp as a comparator

SCHEMATIC DIAGRAM

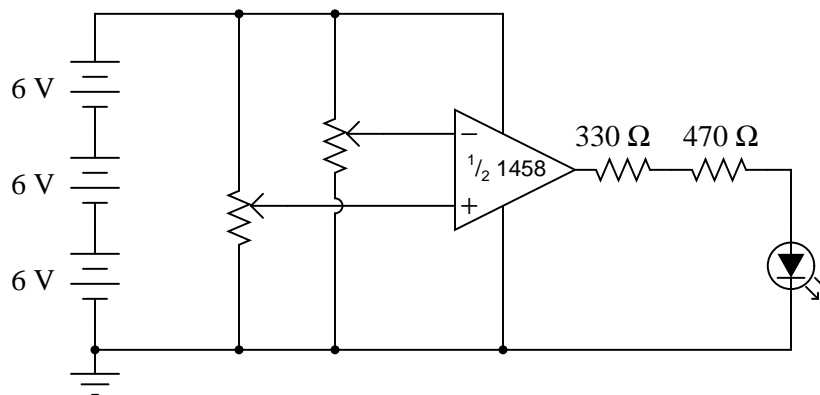

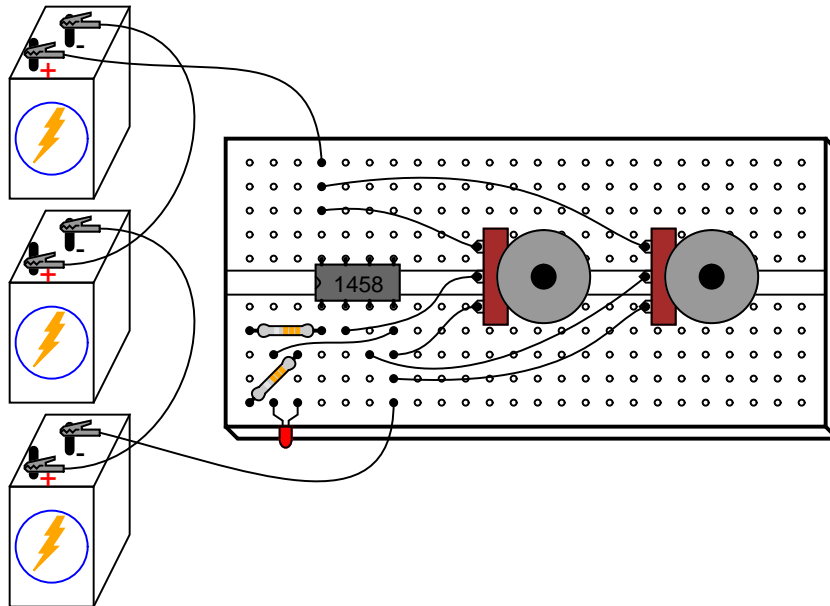
ILLUSTRATION**INSTRUCTIONS**

A *comparator* circuit compares two voltage signals and determines which one is greater. The result of this comparison is indicated by the output voltage: if the op-amp's output is saturated in the positive direction, the noninverting input (+) is a greater, or more positive, voltage than the inverting input (-), all voltages measured with respect to ground. If the op-amp's voltage is near the negative supply voltage (in this case, 0 volts, or ground potential), it means the inverting input (-) has a greater voltage applied to it than the noninverting input (+).

This behavior is much easier understood by experimenting with a comparator circuit than it is by reading someone's verbal description of it. In this experiment, two potentiometers supply variable voltages to be compared by the op-amp. The output status of the op-amp is indicated visually by the LED. By adjusting the two potentiometers and observing the LED, one can easily comprehend the function of a comparator circuit.

For greater insight into this circuit's operation, you might want to connect a pair of voltmeters to the op-amp input terminals (both voltmeters referenced to ground) so that both input voltages may be numerically compared with each other, these meter indications compared to the LED status:

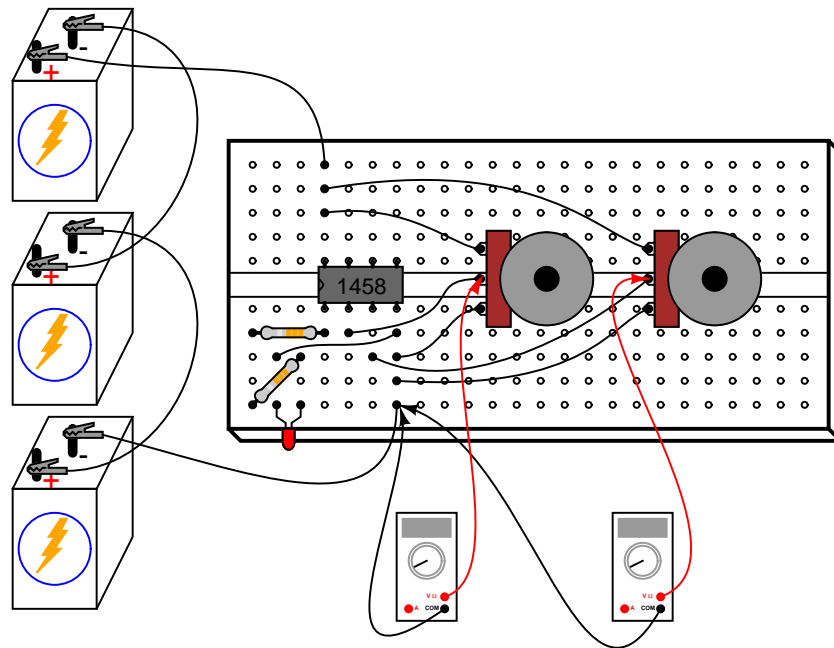

Comparator circuits are widely used to compare physical measurements, provided those physical variables can be translated into voltage signals. For instance, if a small generator were attached to an anemometer wheel to produce a voltage proportional to wind speed, that wind speed signal could be compared with a "set-point" voltage and compared by an op-amp to drive a high wind speed alarm:

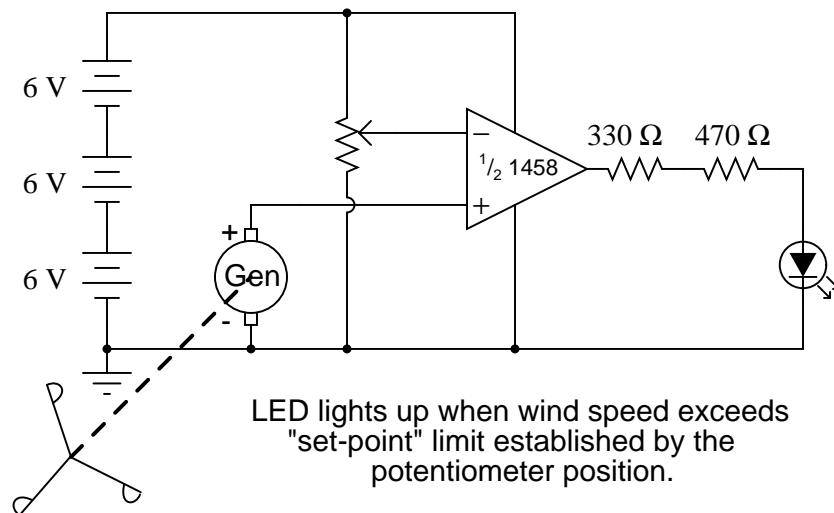

6.3 Precision voltage follower

PARTS AND MATERIALS

- Operational amplifier, model 1458 or 353 recommended (Radio Shack catalog # 276-038 and 900-6298, respectively)
- Three 6 volt batteries
- One 10 k Ω potentiometer, linear taper (Radio Shack catalog # 271-1715)

CROSS-REFERENCES

Lessons In Electric Circuits, Volume 3, chapter 8: "Operational Amplifiers"

LEARNING OBJECTIVES

- How to use an op-amp as a voltage follower
- Purpose of negative feedback
- Troubleshooting strategy

SCHEMATIC DIAGRAM

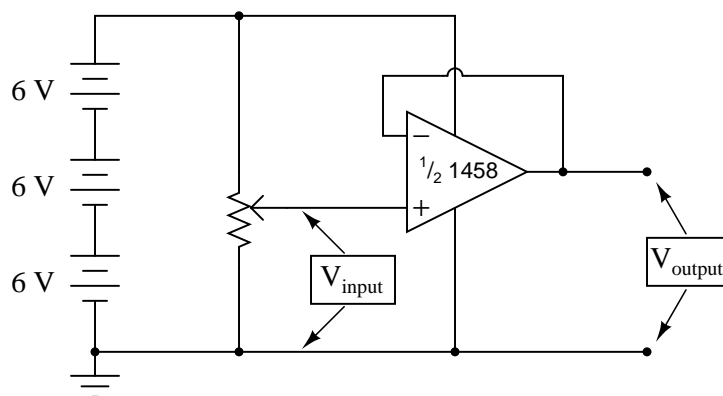

ILLUSTRATION

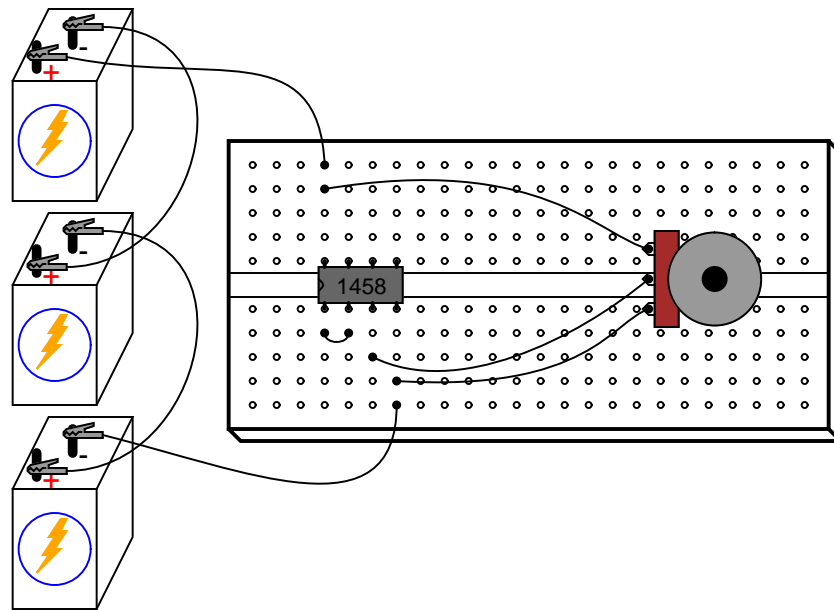

INSTRUCTIONS

In the previous op-amp experiment, the amplifier was used in "open-loop" mode; that is, without any *feedback* from output to input. As such, the full voltage gain of the operational amplifier was available, resulting in the output voltage saturating for virtually any amount of differential voltage applied between the two input terminals. This is good if we desire comparator operation, but if we want the op-amp to behave as a true *amplifier*, we need it to exhibit a manageable voltage gain.

Since we do not have the luxury of disassembling the integrated circuitry of the op-amp and changing resistor values to give a lesser voltage gain, we are limited to external connections and componentry. Actually, this is not a disadvantage as one might think, because the combination of extremely high open-loop voltage gain coupled with feedback allows us to use the op-amp for a much wider variety of purposes, much easier than if we were to exercise the option of modifying its internal circuitry.

If we connect the output of an op-amp to its inverting (-) input, the output voltage will seek whatever level is necessary to balance the inverting input's voltage with that applied to the noninverting (+) input. If this feedback connection is direct, as in a straight piece of wire, the output voltage will precisely "follow" the noninverting input's voltage. Unlike the *voltage follower* circuit made from a single transistor (see chapter 5: Discrete Semiconductor Circuits), which approximated the input voltage to within several tenths of a volt, this voltage follower circuit will output a voltage accurate to within mere *microvolts* of the input voltage!

Measure the input voltage of this circuit with a voltmeter connected between the op-amp's noninverting (+) input terminal and circuit ground (the negative side of the power supply), and the output voltage between the op-amp's output terminal and circuit ground. Watch the op-amp's output voltage follow the input voltage as you adjust the potentiometer through its range.

You may directly measure the difference, or *error*, between output and input voltages by connecting the voltmeter between the op-amp's two input terminals. Throughout most of the potentiometer's range, this error voltage should be almost zero.

Try moving the potentiometer to one of its extreme positions, far clockwise or far counter-clockwise. Measure error voltage, or compare output voltage against input voltage. Do you notice anything unusual? If you are using the model 1458 or model 353 op-amp for this experiment, you should measure a substantial error voltage, or difference between output and input. Many op-amps, the specified models included, cannot "swing" their output voltage exactly to full power supply ("rail") voltage levels. In this case, the "rail" voltages are +18 volts and 0 volts, respectively. Due to limitations in the 1458's internal circuitry, its output voltage is unable to exactly reach these high and low limits. You may find that it can only go within a volt or two of the power supply "rails." This is a very important limitation to understand when designing circuits using operational amplifiers. If full "rail-to-rail" output voltage swing is required in a circuit design, other op-amp models may be selected which offer this capability. The model 3130 is one such op-amp.

Precision voltage follower circuits are useful if the voltage signal to be amplified cannot tolerate "loading;" that is, if it has a high source impedance. Since a voltage follower by definition has a voltage gain of 1, its purpose has nothing to do with amplifying voltage, but rather with amplifying a signal's capacity to deliver *current* to a load.

Voltage follower circuits have another important use for circuit builders: they allow for simple linear testing of an op-amp. One of the troubleshooting techniques I recommend is to *simplify and rebuild*. Suppose that you are building a circuit using one or more op-amps to perform some advanced function. If one of those op-amps seems to be causing a problem and you suspect it may be faulty, try re-connecting it as a simple voltage follower and see if it functions in that capacity. An op-amp that fails to work as a voltage follower certainly won't work as anything more complex!

COMPUTER SIMULATION

Schematic with SPICE node numbers:

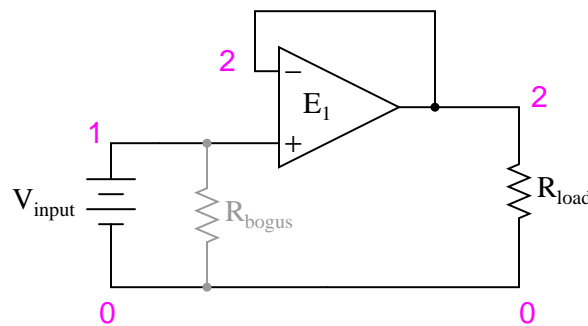

Netlist (make a text file containing the following text, verbatim):

```
Voltage follower
vinput 1 0
rbogus 1 0 1meg
e1 2 0 1 2 999meg
```

```
rload 2 0 10k
.dc vinput 5 5 1
.print dc v(1,0) v(2,0) v(1,2)
.end
```

An ideal operational amplifier may be simulated in SPICE using a *dependent voltage source* (e1 in the netlist). The output nodes are specified first (2 0), then the two input nodes, non-inverting input first (1 2). Open-loop gain is specified last (999meg) in the dependent voltage source line.

Because SPICE views the input impedance of a dependent source as infinite, some finite amount of resistance must be included to avoid an analysis error. This is the purpose of R_{bogus} : to provide DC path to ground for the V_{input} voltage source. Such "bogus" resistances should be arbitrarily large. In this simulation I chose $1\text{ M}\Omega$ for an R_{bogus} value.

A load resistor is included in the circuit for much the same reason: to provide a DC path for current at the output of the dependent voltage source. As you can see, SPICE doesn't like open circuits!

6.4 Noninverting amplifier

PARTS AND MATERIALS

- Operational amplifier, model 1458 or 353 recommended (Radio Shack catalog # 276-038 and 900-6298, respectively)
- Three 6 volt batteries
- Two 10 k Ω potentiometers, linear taper (Radio Shack catalog # 271-1715)

CROSS-REFERENCES

Lessons In Electric Circuits, Volume 3, chapter 8: "Operational Amplifiers"

LEARNING OBJECTIVES

- How to use an op-amp as a single-ended amplifier
- Using divided, negative feedback

SCHEMATIC DIAGRAM

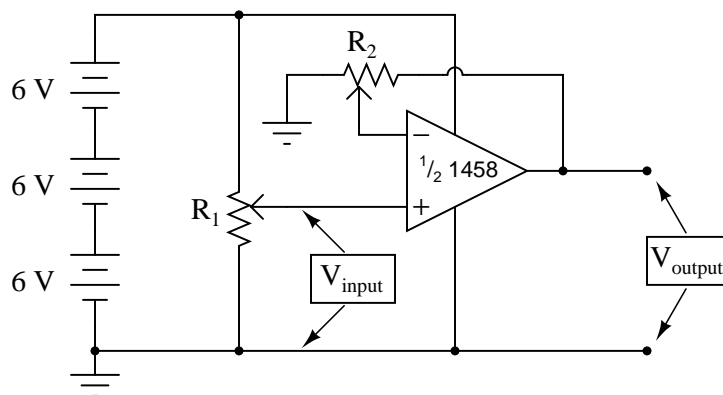

ILLUSTRATION

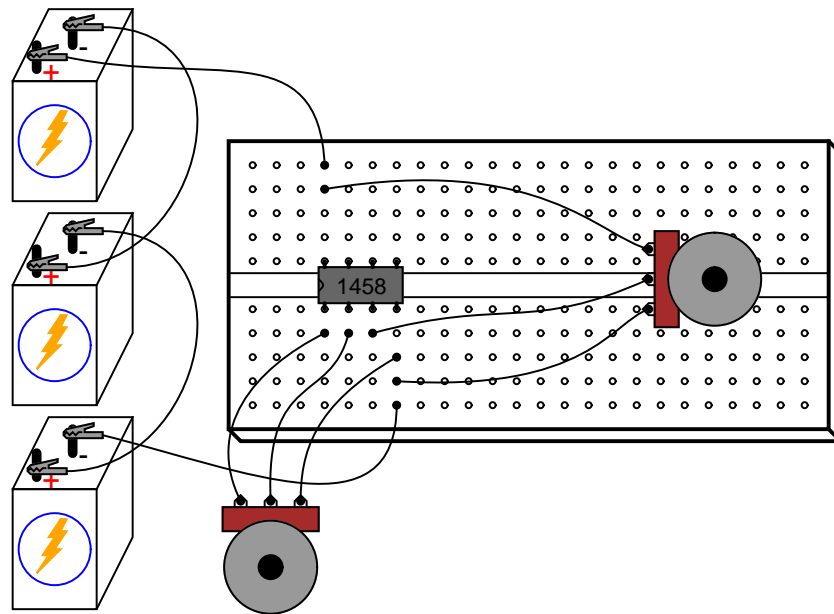

INSTRUCTIONS

This circuit differs from the voltage follower in only one respect: output voltage is "fed back" to the inverting (-) input through a voltage-dividing potentiometer rather than being directly connected. With only a *fraction* of the output voltage fed back to the inverting input, the op-amp will output a corresponding *multiple* of the voltage sensed at the noninverting (+) input in keeping the input differential voltage near zero. In other words, the op-amp will now function as an amplifier with a controllable voltage gain, that gain being established by the position of the feedback potentiometer (R_2).

Set R_2 to approximately mid-position. This should give a voltage gain of about 2. Measure both input and output voltage for several positions of the input potentiometer R_1 . Move R_2 to a different position and re-take voltage measurements for several positions of R_1 . For any given R_2 position, the ratio between output and input voltage should be the same.

You will also notice that the input and output voltages are always positive with respect to ground. Because the output voltage increases in a positive direction for a positive increase of the input voltage, this amplifier is referred to as *noninverting*. If the output and input voltages were related to one another in an inverse fashion (i.e. positive increasing input voltage results in positive decreasing or negative increasing output), then the amplifier would be known as an *inverting* type.

The ability to leverage an op-amp in this fashion to create an amplifier with controllable voltage gain makes this circuit an extremely useful one. It would take quite a bit more design and troubleshooting effort to produce a similar circuit using discrete transistors.

Try adjusting R_2 for maximum and minimum voltage gain. What is the *lowest* voltage gain attainable with this amplifier configuration? Why do you think this is?

COMPUTER SIMULATION

Schematic with SPICE node numbers:

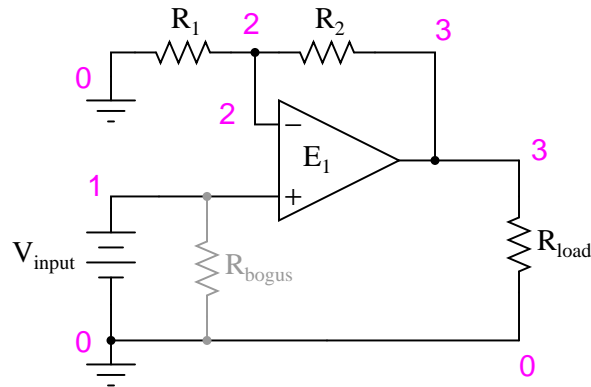

Netlist (make a text file containing the following text, verbatim):

```
Noninverting amplifier
vinput 1 0
r2 3 2 5k
r1 2 0 5k
rbogus 1 0 1meg
e1 3 0 1 2 999meg
rload 3 0 10k
.dc vinput 5 5 1
.print dc v(1,0) v(3,0)
.end
```

With R_1 and R_2 set equally to $5\text{ k}\Omega$ in the simulation, it mimics the feedback potentiometer of the real circuit at mid-position (50%). To simulate the potentiometer at the 75% position, set R_2 to $7.5\text{ k}\Omega$ and R_1 to $2.5\text{ k}\Omega$.

6.5 High-impedance voltmeter

PARTS AND MATERIALS

- Operational amplifier, model TL082 recommended (Radio Shack catalog # 276-1715)
- Operational amplifier, model LM1458 recommended (Radio Shack catalog # 276-038)
- Four 6 volt batteries
- One meter movement, 1 mA full-scale deflection (Radio Shack catalog #22-410)
- 15 k Ω precision resistor
- Four 1 M Ω resistors

The 1 mA meter movement sold by Radio Shack is advertised as a 0-15 VDC meter, but is actually a 1 mA movement sold with a 15 k Ω +/- 1% tolerance multiplier resistor. If you get this Radio Shack meter movement, you can use the included 15 k Ω resistor for the resistor specified in the parts list.

This meter experiment is based on a JFET-input op-amp such as the TL082. The other op-amp (model 1458) is used in this experiment to demonstrate the absence of latch-up: a problem inherent to the TL082.

You don't need 1 M Ω resistors, *exactly*. Any very high resistance resistors will suffice.

CROSS-REFERENCES

Lessons In Electric Circuits, Volume 3, chapter 8: "Operational Amplifiers"

LEARNING OBJECTIVES

- Voltmeter loading: its causes and its solution
- How to make a high-impedance voltmeter using an op-amp
- What op-amp "latch-up" is and how to avoid it

SCHEMATIC DIAGRAM

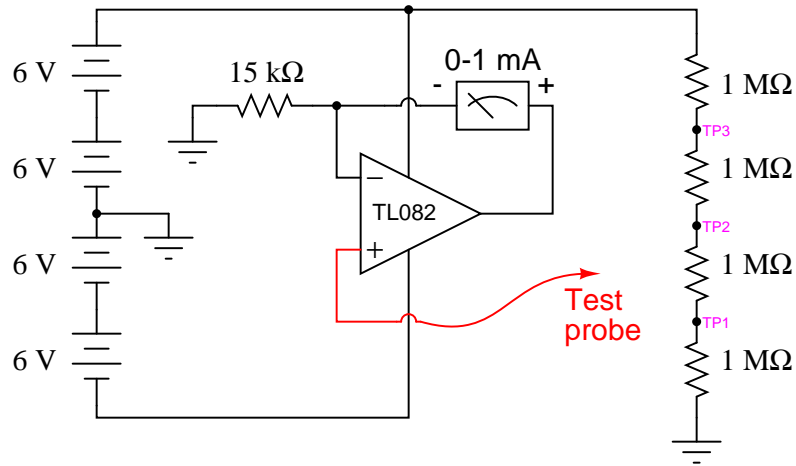
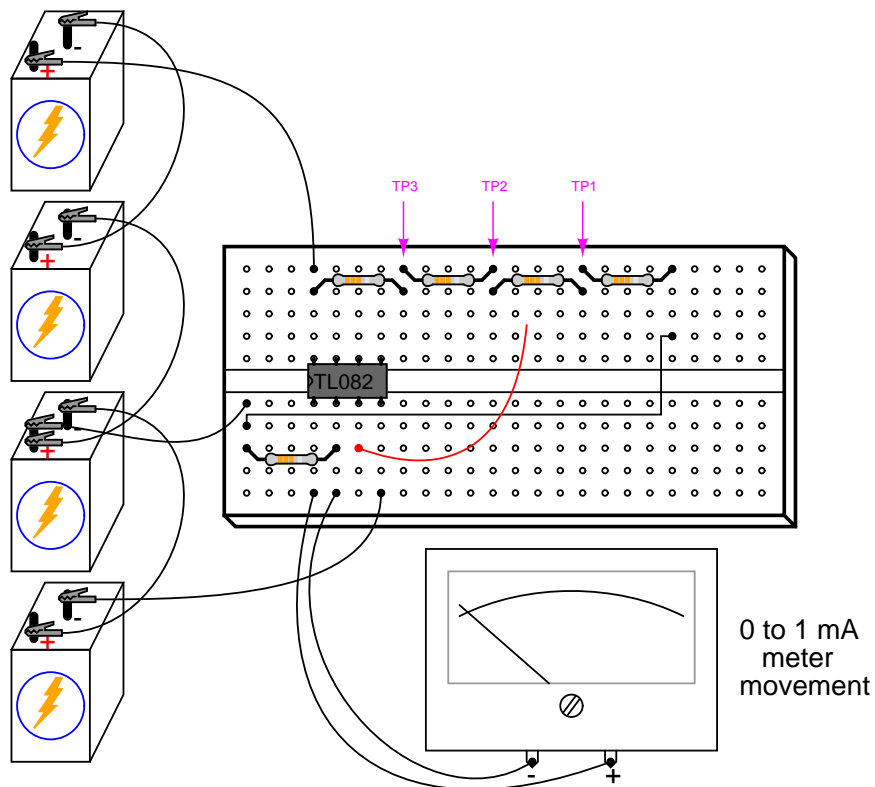
**ILLUSTRATION****INSTRUCTIONS**

An ideal voltmeter has infinite input impedance, meaning that it draws zero current from the circuit under test. This way, there will be no "impact" on the circuit as the voltage is

being measured. The more current a voltmeter draws from the circuit under test, the more the measured voltage will "sag" under the loading effect of the meter, like a tire-pressure gauge releasing air out of the tire being measured: the more air released from the tire, the more the tire's pressure will be impacted in the act of measurement. This loading is more pronounced on circuits of high resistance, like the voltage divider made of $1\text{ M}\Omega$ resistors, shown in the schematic diagram.

If you were to build a simple 0-15 volt range voltmeter by connecting the 1 mA meter movement in series with the $15\text{ k}\Omega$ precision resistor, and try to use this voltmeter to measure the voltages at TP1, TP2, or TP3 (with respect to ground), you'd encounter *severe* measurement errors induced by meter "impact:"

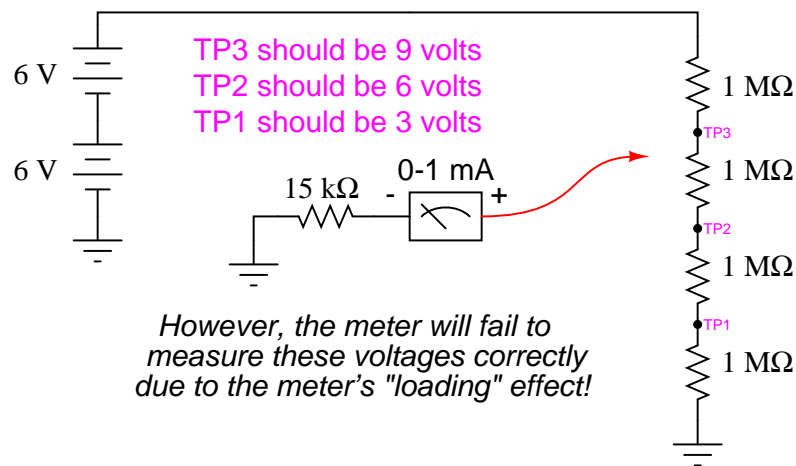

Try using the meter movement and $15\text{ k}\Omega$ resistor as shown to measure these three voltages. Does the meter read falsely high or falsely low? Why do you think this is?

If we were to increase the meter's input impedance, we would diminish its current draw or "load" on the circuit under test and consequently improve its measurement accuracy. An op-amp with high-impedance inputs (using a JFET transistor input stage rather than a BJT input stage) works well for this application.

Note that the meter movement is part of the op-amp's feedback loop from output to inverting input. This circuit drives the meter movement with a current proportional to the voltage impressed at the noninverting (+) input, the requisite current supplied directly from the batteries through the op-amp's power supply pins, not from the circuit under test through the test probe. The meter's range is set by the resistor connecting the inverting (-) input to ground.

Build the op-amp meter circuit as shown and re-take voltage measurements at TP1, TP2, and TP3. You should enjoy far better success this time, with the meter movement accurately measuring these voltages (approximately 3, 6, and 9 volts, respectively).

You may witness the extreme sensitivity of this voltmeter by touching the test probe with one hand and the most positive battery terminal with the other. Notice how you can drive the needle upward on the scale simply by measuring battery voltage through your body resistance: an impossible feat with the original, unamplified voltmeter circuit. If you touch the test probe to ground, the meter should read exactly 0 volts.

After you've proven this circuit to work, modify it by changing the power supply from dual to split. This entails removing the center-tap ground connection between the 2nd and 3rd batteries, and grounding the far negative battery terminal instead:

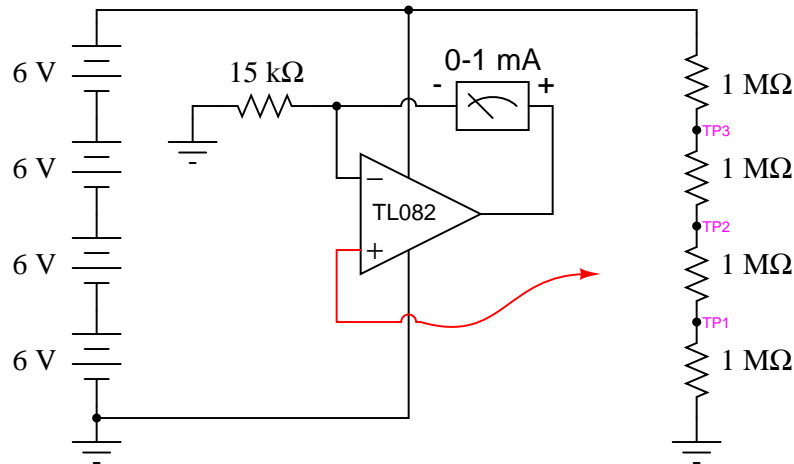

This alteration in the power supply increases the voltages at TP1, TP2, and TP3 to 6, 12, and 18 volts, respectively. With a 15 k Ω range resistor and a 1 mA meter movement, measuring 18 volts will gently "peg" the meter, but you should be able to measure the 6 and 12 volt test points just fine.

Try touching the meter's test probe to ground. This *should* drive the meter needle to exactly 0 volts as before, but it will not! What is happening here is an op-amp phenomenon called *latch-up*: where the op-amp output drives to a positive voltage when the input common-mode voltage exceeds the allowable limit. In this case, as with many JFET-input op-amps, neither input should be allowed to come close to either power supply rail voltage. With a single supply, the op-amp's negative power rail is at ground potential (0 volts), so grounding the test probe brings the noninverting (+) input exactly to that rail voltage. This is bad for a JFET op-amp, and drives the output strongly positive, even though it doesn't seem like it should, based on how op-amps are supposed to function.

When the op-amp ran on a "dual" supply (+12/-12 volts, rather than a "single" +24 volt supply), the negative power supply rail was 12 volts away from ground (0 volts), so grounding the test probe didn't violate the op-amp's common-mode voltage limit. However, with the "single" +24 volt supply, we have a problem. Note that some op-amps do not "latch-up" the way the model TL082 does. You may replace the TL082 with an LM1458 op-amp, which is pin-for-pin compatible (no breadboard wiring changes needed). The model 1458 will not "latch-up" when the test probe is grounded, although you may still get incorrect meter readings with the measured voltage exactly equal to the negative power supply rail. As a general rule, you should always be sure the op-amp's power supply rail voltages exceed the expected input voltages.

6.6 Integrator

PARTS AND MATERIALS

- Four 6 volt batteries
- Operational amplifier, model 1458 recommended (Radio Shack catalog # 276-038)
- One 10 k Ω potentiometer, linear taper (Radio Shack catalog # 271-1715)
- Two capacitors, 0.1 μ F each, non-polarized (Radio Shack catalog # 272-135)
- Two 100 k Ω resistors
- Two 1 M Ω resistors
- Three 1 M Ω resistors

Just about any operational amplifier model will work fine for this integrator experiment, but I'm specifying the model 1458 over the 353 because the 1458 has much higher input bias currents. Normally, high input bias current is a bad characteristic for an op-amp to have in a precision DC amplifier circuit (and especially an integrator circuit!). However, I want the bias current to be high in order that its bad effects may be exaggerated, and so that you will learn one method of counteracting its effects.

CROSS-REFERENCES

Lessons In Electric Circuits, Volume 3, chapter 8: "Operational Amplifiers"

LEARNING OBJECTIVES

- Method for limiting the span of a potentiometer
- Purpose of an integrator circuit
- How to compensate for op-amp bias current

SCHEMATIC DIAGRAM

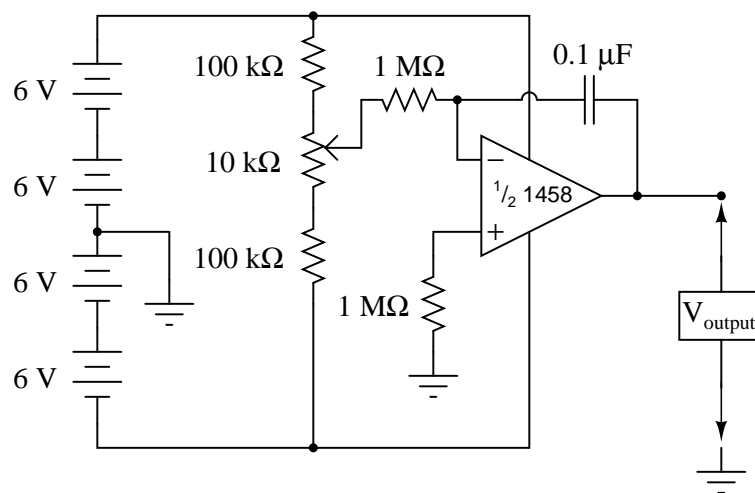

ILLUSTRATION

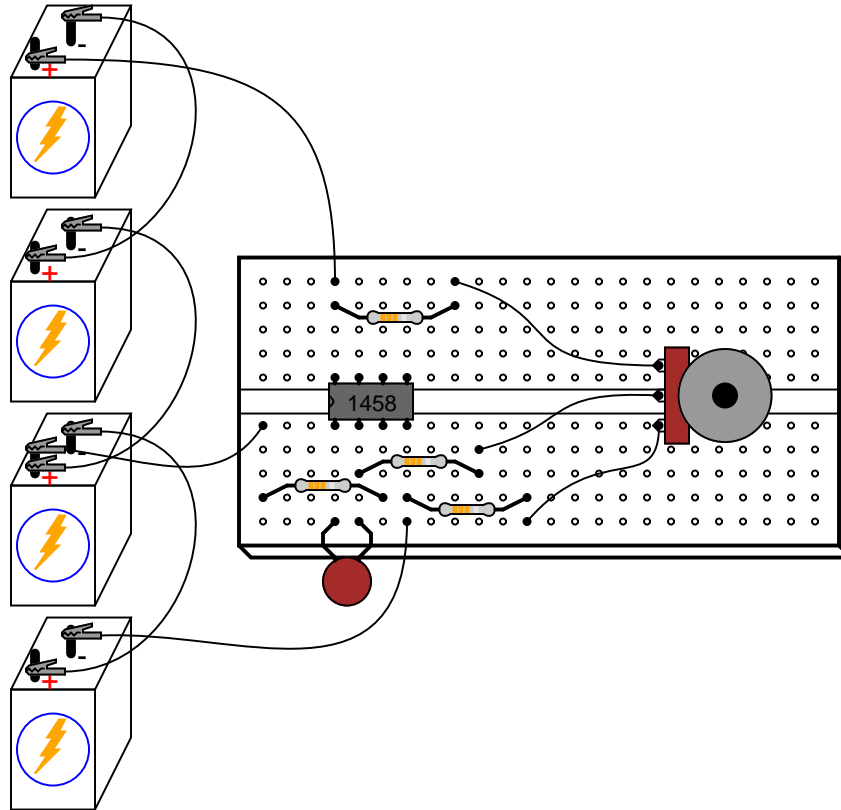

INSTRUCTIONS

As you can see from the schematic diagram, the potentiometer is connected to the "rails" of the power source through 100 k Ω resistors, one on each end. This is to limit the span of the potentiometer, so that full movement produces a fairly small range of input voltages for the op-amp to operate on. At one extreme of the potentiometer's motion, a voltage of about 0.5 volt (with respect to the ground point in the middle of the series battery string) will be produced at the potentiometer wiper. At the other extreme of motion, a voltage of about -0.5 volt will be produced. When the potentiometer is positioned dead-center, the wiper voltage should measure zero volts.

Connect a voltmeter between the op-amp's output terminal and the circuit ground point. Slowly move the potentiometer control while monitoring the output voltage. The output voltage should be *changing* at a rate established by the potentiometer's deviation from zero (center) position. To use calculus terms, we would say that the output voltage represents the *integral* (with respect to time) of the input voltage function. That is, the input voltage level establishes the output voltage *rate of change over time*. This is precisely the opposite of *differentiation*, where the *derivative* of a signal or function is its instantaneous rate of change.

If you have two voltmeters, you may readily see this relationship between input voltage and output *voltage rate of change* by measuring the wiper voltage (between the potentiometer

wiper and ground) with one meter and the output voltage (between the op-amp output terminal and ground) with the other. Adjusting the potentiometer to give zero volts should result in the slowest output voltage rate-of-change. Conversely, the more voltage input to this circuit, the faster its output voltage will change, or "ramp."

Try connecting the second $0.1\ \mu\text{F}$ capacitor in parallel with the first. This will double the amount of capacitance in the op-amp's feedback loop. What affect does this have on the circuit's integration rate for any given potentiometer position?

Try connecting another $1\ \text{M}\Omega$ resistor in parallel with the input resistor (the resistor connecting the potentiometer wiper to the inverting terminal of the op-amp). This will halve the integrator's input resistance. What affect does this have on the circuit's integration rate?

Integrator circuits are one of the fundamental "building-block" functions of an analog computer. By connecting integrator circuits with amplifiers, summers, and potentiometers (dividers), almost any differential equation could be modeled, and solutions obtained by measuring voltages produced at various points in the network of circuits. Because differential equations describe so many physical processes, analog computers are useful as simulators. Before the advent of modern digital computers, engineers used analog computers to simulate such processes as machinery vibration, rocket trajectory, and control system response. Even though analog computers are considered obsolete by modern standards, their constituent components still work well as learning tools for calculus concepts.

Move the potentiometer until the op-amp's output voltage is as close to zero as you can get it, and moving as slowly as you can make it. Disconnect the integrator input from the potentiometer wiper terminal and connect it instead to ground, like this:

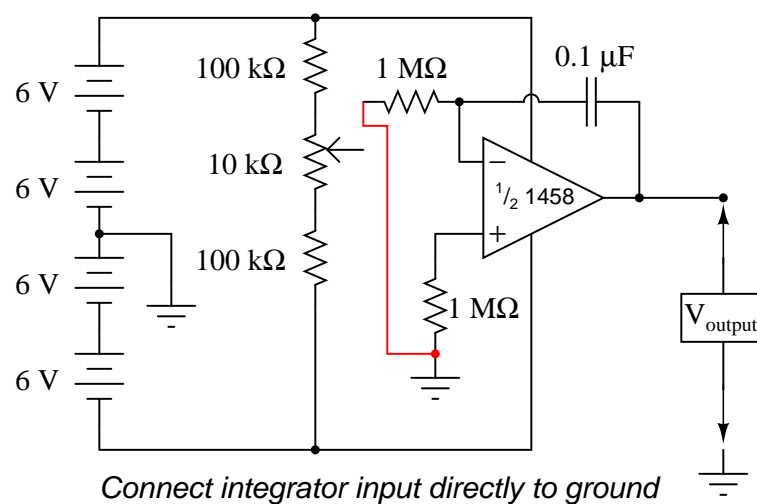

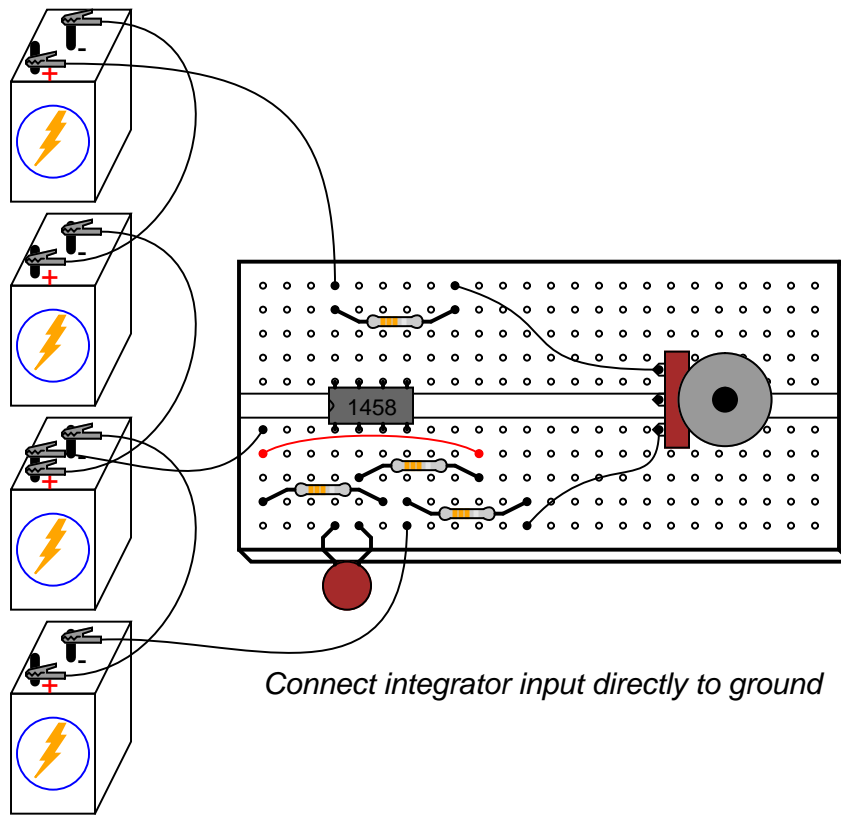

Applying exactly zero voltage to the input of an integrator circuit should, ideally, cause the output voltage rate-of-change to be zero. When you make this change to the circuit, you should notice the output voltage remaining at a constant level or changing very slowly.

With the integrator input still shorted to ground, short past the 1 MΩ resistor connecting the op-amp's noninverting (+) input to ground. There should be no need for this resistor in an ideal op-amp circuit, so by shorting past it we will see what function it provides in this very *real* op-amp circuit:

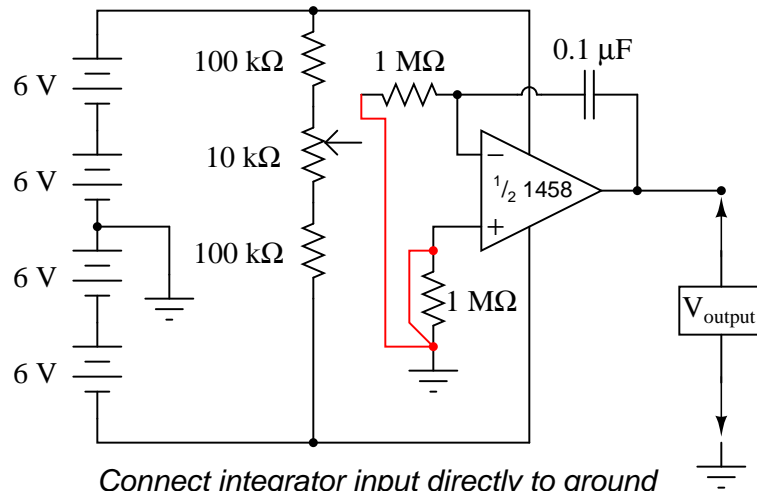

Connect integrator input directly to ground
Short past the "grounding" resistor

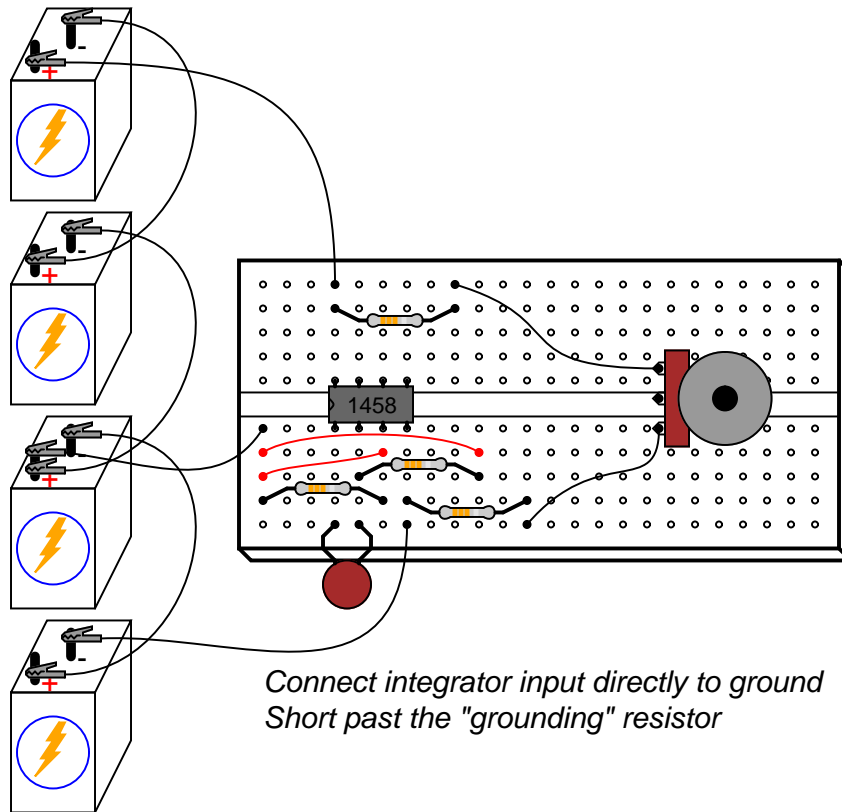

Connect integrator input directly to ground
Short past the "grounding" resistor

As soon as the "grounding" resistor is shorted with a jumper wire, the op-amp's output voltage will start to change, or drift. Ideally, this should not happen, because the integrator

circuit still has an input signal of zero volts. However, real operational amplifiers have a very small amount of current entering each input terminal called the *bias current*. These bias currents will drop voltage across any resistance in their path. Since the $1\text{ M}\Omega$ input resistor conducts some amount of bias current regardless of input signal magnitude, it will drop voltage across its terminals due to bias current, thus "offsetting" the amount of signal voltage seen at the inverting terminal of the op-amp. If the other (noninverting) input is connected directly to ground as we have done here, this "offset" voltage incurred by voltage drop generated by bias current will cause the integrator circuit to slowly "integrate" as though it were receiving a very small input signal.

The "grounding" resistor is better known as a *compensating resistor*, because it acts to compensate for voltage errors created by bias current. Since the bias currents through each op-amp input terminal are approximately equal to each other, an equal amount of resistance placed in the path of each bias current will produce approximately the same voltage drop. Equal voltage drops seen at the complementary inputs of an op-amp cancel each other out, thus nulling the error otherwise induced by bias current.

Remove the jumper wire shorting past the compensating resistor and notice how the op-amp output returns to a relatively stable state. It may still drift some, most likely due to *bias voltage* error in the op-amp itself, but that is another subject altogether!

COMPUTER SIMULATION

Schematic with SPICE node numbers:

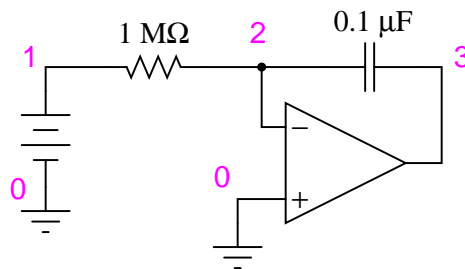

Netlist (make a text file containing the following text, verbatim):

```
DC integrator
vinput 1 0 dc 0.05
r1 1 2 1meg
c1 2 3 0.1u ic=0
e1 3 0 0 2 999k
.tran 1 30 uic
.plot tran v(1,0) v(3,0)
.end
```

6.7 555 audio oscillator

PARTS AND MATERIALS

- Two 6 volt batteries
- One capacitor, $0.1 \mu\text{F}$, non-polarized (Radio Shack catalog # 272-135)
- One 555 timer IC (Radio Shack catalog # 276-1723)
- Two light-emitting diodes (Radio Shack catalog # 276-026 or equivalent)
- One $1 \text{ M}\Omega$ resistor
- One $100 \text{ k}\Omega$ resistor
- Two 510Ω resistors
- Audio detector with headphones
- Oscilloscope (recommended, but not necessary)

A oscilloscope would be useful in analyzing the waveforms produced by this circuit, but it is not essential. An audio detector is a very useful piece of test equipment for this experiment, especially if you don't have an oscilloscope.

CROSS-REFERENCES

Lessons In Electric Circuits, Volume 4, chapter 10: "Multivibrators"

LEARNING OBJECTIVES

- How to use the 555 timer as an astable multivibrator
- Working knowledge of duty cycle

SCHEMATIC DIAGRAM

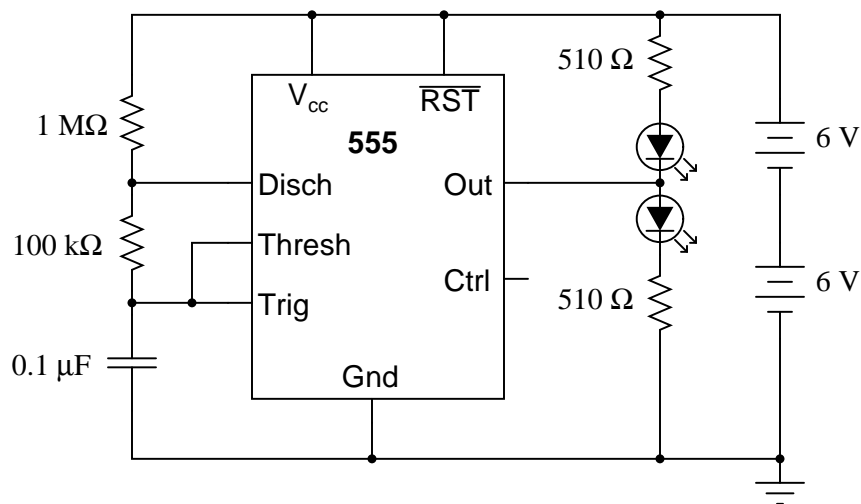

ILLUSTRATION

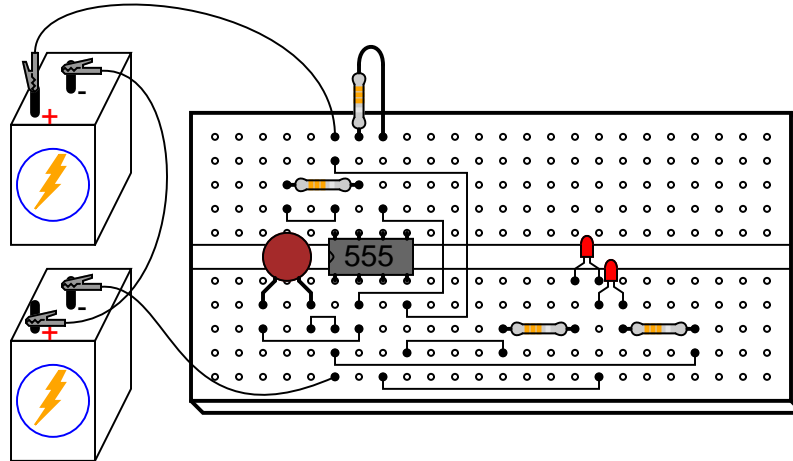

INSTRUCTIONS

The "555" integrated circuit is a general-purpose timer useful for a variety of functions. In this experiment, we explore its use as an astable multivibrator, or oscillator. Connected to a capacitor and two resistors as shown, it will oscillate freely, driving the LEDs on and off with a square-wave output voltage.

This circuit works on the principle of alternately charging and discharging a capacitor. The 555 begins to discharge the capacitor by grounding the *Disch* terminal when the voltage detected by the *Thresh* terminal exceeds $2/3$ the power supply voltage (V_{cc}). It stops discharging the capacitor when the voltage detected by the *Trig* terminal falls below $1/3$ the power supply voltage. Thus, when both *Thresh* and *Trig* terminals are connected to the capacitor's positive terminal, the capacitor voltage will cycle between $1/3$ and $2/3$ power supply voltage in a "sawtooth" pattern.

During the charging cycle, the capacitor receives charging current through the series combination of the $1\text{ M}\Omega$ and $100\text{ k}\Omega$ resistors. As soon as the *Disch* terminal on the 555 timer goes to ground potential (a transistor inside the 555 connected between that terminal and ground turns on), the capacitor's discharging current only has to go through the $100\text{ k}\Omega$ resistor. The result is an RC time constant that is much longer for charging than for discharging, resulting in a charging time greatly exceeding the discharging time.

The 555's *Out* terminal produces a square-wave voltage signal that is "high" (nearly V_{cc}) when the capacitor is charging, and "low" (nearly 0 volts) when the capacitor is discharging. This alternating high/low voltage signal drives the two LEDs in opposite modes: when one is on, the other will be off. Because the capacitor's charging and discharging times are unequal, the "high" and "low" times of the output's square-wave waveform will be unequal as well. This can be seen in the relative brightness of the two LEDs: one will be much brighter than the other, because it is on for a longer period of time during each cycle.

The equality or inequality between "high" and "low" times of a square wave is expressed as that wave's *duty cycle*. A square wave with a 50% duty cycle is perfectly symmetrical: its "high" time is precisely equal to its "low" time. A square wave that is "high" 10% of the time

and "low" 90% of the time is said to have a 10% duty cycle. In this circuit, the output waveform has a "high" time exceeding the "low" time, resulting in a duty cycle greater than 50%.

Use the audio detector (or an oscilloscope) to investigate the different voltage waveforms produced by this circuit. Try different resistor values and/or capacitor values to see what effects they have on output frequency or charge/discharge times.

6.8 555 ramp generator

PARTS AND MATERIALS

- Two 6 volt batteries
- One capacitor, 470 μF electrolytic, 35 WVDC (Radio Shack catalog # 272-1030 or equivalent)
- One capacitor, 0.1 μF , non-polarized (Radio Shack catalog # 272-135)
- One 555 timer IC (Radio Shack catalog # 276-1723)
- Two PNP transistors – models 2N2907 or 2N3906 recommended (Radio Shack catalog # 276-1604 is a package of fifteen PNP transistors ideal for this and other experiments)
- Two light-emitting diodes (Radio Shack catalog # 276-026 or equivalent)
- One 100 k Ω resistor
- One 47 k Ω resistor
- Two 510 Ω resistors
- Audio detector with headphones

The voltage rating on the 470 μF capacitor is not critical, so long as it generously exceeds the maximum power supply voltage. In this particular circuit, that maximum voltage is 12 volts. Be sure you connect this capacitor in the circuit properly, respecting polarity!

CROSS-REFERENCES

Lessons In Electric Circuits, Volume 1, chapter 13: "Capacitors"

Lessons In Electric Circuits, Volume 4, chapter 10: "Multivibrators"

LEARNING OBJECTIVES

- How to use the 555 timer as an astable multivibrator
- A practical use for a current mirror circuit
- Understanding the relationship between capacitor current and capacitor voltage rate-of-change

SCHEMATIC DIAGRAM

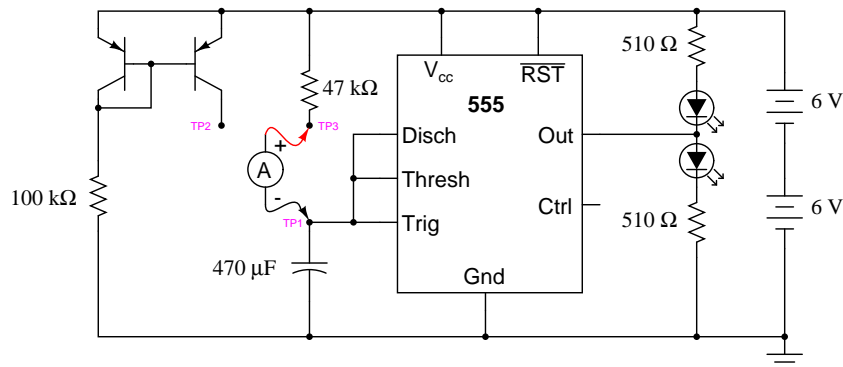

ILLUSTRATION

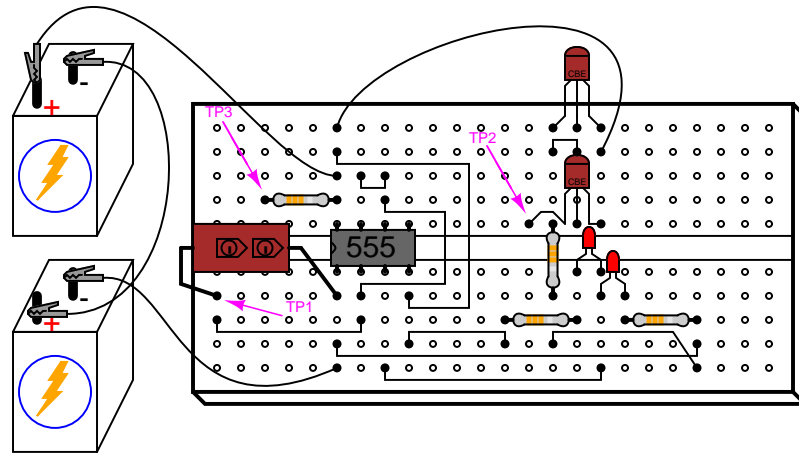

INSTRUCTIONS

Again, we are using a 555 timer IC as an astable multivibrator, or oscillator. This time, however, we will compare its operation in two different capacitor-charging modes: traditional RC and constant-current.

Connecting test point #1 (TP1) to test point #3 (TP3) using a jumper wire. This allows the capacitor to charge through a $47\text{ k}\Omega$ resistor. When the capacitor has reached $2/3$ supply voltage, the 555 timer switches to "discharge" mode and discharges the capacitor to a level of $1/3$ supply voltage almost immediately. The charging cycle begins again at this point. Measure voltage directly across the capacitor with a voltmeter (a digital voltmeter is preferred), and note the rate of capacitor charging over time. It should rise quickly at first, then taper off as it builds up to $2/3$ supply voltage, just as you would expect from an RC charging circuit.

Remove the jumper wire from TP3, and re-connect it to TP2. This allows the capacitor to be charged through the controlled-current leg of a current mirror circuit formed by the two PNP transistors. Measure voltage directly across the capacitor again, noting the difference in charging rate over time as compared to the last circuit configuration.

By connecting TP1 to TP2, the capacitor receives a nearly constant charging current. Constant capacitor charging current yields a voltage curve that is linear, as described by the equation $i = C(de/dt)$. If the capacitor's current is constant, so will be its rate-of-change of voltage over time. The result is a "ramp" waveform rather than a "sawtooth" waveform:



Sawtooth waveform (RC circuit)

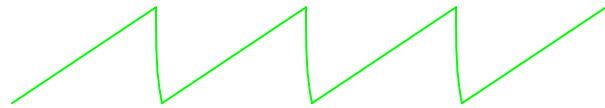

Ramp waveform (constant current)

The capacitor's charging current may be directly measured by substituting an ammeter in place of the jumper wire. The ammeter will need to be set to measure a current in the range of hundreds of microamps (tenths of a milliamp). Connected between TP1 and TP3, you should see a current that starts at a relatively high value at the beginning of the charging cycle, and tapers off toward the end. Connected between TP1 and TP2, however, the current will be much more stable.

It is an interesting experiment at this point to change the temperature of either current mirror transistor by touching it with your finger. As the transistor warms, it will conduct more collector current for the same base-emitter voltage. If the *controlling* transistor (the one connected to the 100 k Ω resistor) is touched, the current decreases. If the *controlled* transistor is touched, the current increases. For the most stable current mirror operation, the two transistors should be cemented together so that their temperatures never differ by any substantial amount.

This circuit works just as well at high frequencies as it does at low frequencies. Replace the 470 μF capacitor with a 0.1 μF capacitor, and use an audio detector to sense the voltage waveform at the 555's output terminal. The detector should produce an audio tone that is easy to hear. The capacitor's voltage will now be changing much too fast to view with a voltmeter in the DC mode, but we can still measure capacitor current with an ammeter.

With the ammeter connected between TP1 and TP3 (RC mode), measure both DC microamps and AC microamps. Record these current figures on paper. Now, connect the ammeter between TP1 and TP2 (constant-current mode). Measure both DC microamps and AC microamps, noting any differences in current readings between this circuit configuration and the last one. Measuring AC current in addition to DC current is an easy way to determine which circuit configuration gives the most stable charging current. If the current mirror circuit were perfect – the capacitor charging current absolutely constant – there would be zero AC current measured by the meter.

6.9 PWM power controller

PARTS AND MATERIALS

- Four 6 volt batteries
- One capacitor, 100 μF electrolytic, 35 WVDC (Radio Shack catalog # 272-1028 or equivalent)
- One capacitor, 0.1 μF , non-polarized (Radio Shack catalog # 272-135)
- One 555 timer IC (Radio Shack catalog # 276-1723)
- Dual operational amplifier, model 1458 recommended (Radio Shack catalog # 276-038)
- One NPN power transistor – (Radio Shack catalog # 276-2041 or equivalent)
- Three 1N4001 rectifying diodes (Radio Shack catalog # 276-1101)
- One 10 k Ω potentiometer, linear taper (Radio Shack catalog # 271-1715)
- One 33 k Ω resistor
- 12 volt automotive tail-light lamp
- Audio detector with headphones

CROSS-REFERENCES

Lessons In Electric Circuits, Volume 3, chapter 8: "Operational Amplifiers"

Lessons In Electric Circuits, Volume 2, chapter 7: "Mixed-Frequency AC Signals"

LEARNING OBJECTIVES

- How to use the 555 timer as an astable multivibrator
- How to use an op-amp as a comparator
- How to use diodes to drop unwanted DC voltage
- How to control power to a load by pulse-width modulation

SCHEMATIC DIAGRAM

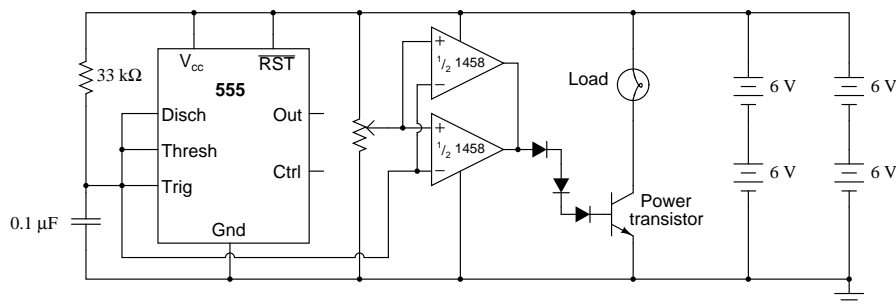

ILLUSTRATION

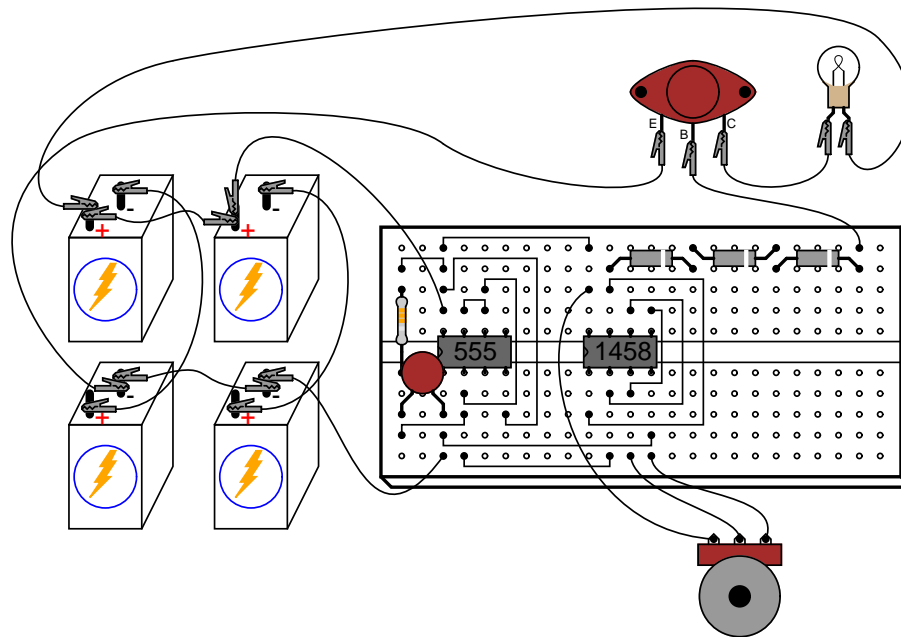

INSTRUCTIONS

This circuit uses a 555 timer to generate a sawtooth voltage waveform across a capacitor, then compares that signal against a steady voltage provided by a potentiometer, using an op-amp as a comparator. The comparison of these two voltage signals produces a square-wave output from the op-amp, varying in duty cycle according to the potentiometer's position. This variable duty cycle signal then drives the base of a power transistor, switching current on and off through the load. The 555's oscillation frequency is much higher than the lamp filament's ability to thermally cycle (heat and cool), so any variation in duty cycle, or *pulse width*, has the effect of controlling the total power dissipated by the load over time.

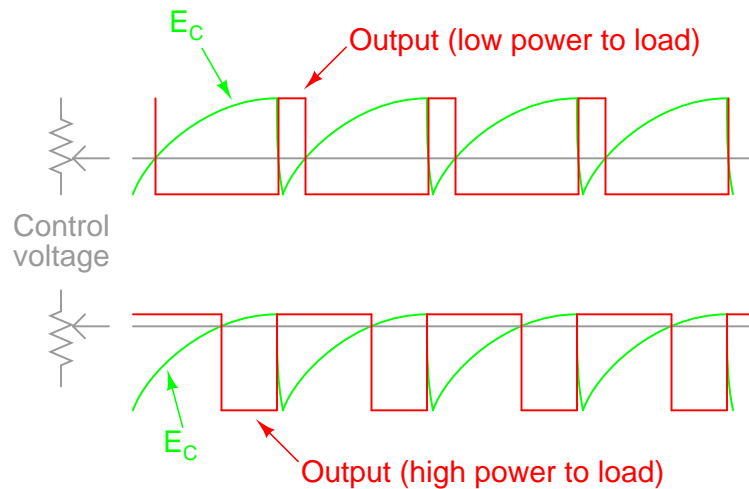

Controlling electrical power through a load by means of quickly switching it on and off, and varying the "on" time, is known as *pulse-width modulation*, or *PWM*. It is a very efficient means of controlling electrical power because the controlling element (the power transistor) dissipates comparatively little power in switching on and off, especially if compared to the wasted power dissipated of a rheostat in a similar situation. When the transistor is in cutoff, its power dissipation is zero because there is no current through it. When the transistor is saturated, its dissipation is very low because there is little voltage dropped between collector and emitter while it is conducting current.

PWM is a concept easier understood through experimentation than reading. It would be nice to view the capacitor voltage, potentiometer voltage, and op-amp output waveforms all on one (triple-trace) oscilloscope to see how they relate to one another, and to the load power. However, most of us have no access to a triple-trace oscilloscope, much less any oscilloscope at all, so an alternative method is to slow the 555 oscillator down enough that the three voltages may be compared with a simple DC voltmeter. Replace the $0.1 \mu\text{F}$ capacitor with one that is $100 \mu\text{F}$ or larger. This will slow the oscillation frequency down by a factor of at least a thousand, enabling you to measure the capacitor voltage *slowly* rise over time, and the op-amp output transition from "high" to "low" when the capacitor voltage becomes greater than the potentiometer voltage. With such a slow oscillation frequency, the load power will not be proportioned as before. Rather, the lamp will turn on and off at regular intervals. Feel free to experiment with other capacitor or resistor values to speed up the oscillations enough so the lamp never fully turns on or off, but is "throttled" by quick on-and-off pulsing of the transistor.

When you examine the schematic, you will notice *two* operational amplifiers connected in parallel. This is done to provide maximum current output to the base terminal of the power transistor. A single op-amp (one-half of a 1458 IC) may not be able to provide sufficient output current to drive the transistor into saturation, so two op-amps are used in tandem. This should only be done if the op-amps in question are overload-protected, which the 1458 series of op-amps are. Otherwise, it is possible (though unlikely) that one op-amp could turn on before the other, and damage result from the two outputs short-circuiting each other (one driving "high" and the other driving "low" simultaneously). The inherent short-circuit protection offered by the 1458 allows for direct driving of the power transistor base without any need for a current-

limiting resistor.

The three diodes in series connecting the op-amps' outputs to the transistor's base are there to drop voltage and ensure the transistor falls into cutoff when the op-amp outputs go "low." Because the 1458 op-amp cannot swing its output voltage all the way down to ground potential, but only to within about 2 volts of ground, a direct connection from the op-amp to the transistor would mean the transistor would never fully turn off. Adding three silicon diodes in series drops approximately 2.1 volts (0.7 volts times 3) to ensure there is minimal voltage at the transistor's base when the op-amp outputs go "low."

It is interesting to listen to the op-amp output signal through an audio detector as the potentiometer is adjusted through its full range of motion. Adjusting the potentiometer has no effect on signal frequency, but it greatly affects duty cycle. Note the difference in tone quality, or *timbre*, as the potentiometer varies the duty cycle from 0% to 50% to 100%. Varying the duty cycle has the effect of changing the harmonic content of the waveform, which makes the tone sound different.

You might notice a particular uniqueness to the sound heard through the detector headphones when the potentiometer is in center position (50% duty cycle – 50% load power), versus a kind of similarity in sound just above or below 50% duty cycle. This is due to the absence or presence of even-numbered harmonics. Any waveform that is symmetrical above and below its centerline, such as a square wave with a 50% duty cycle, contains *no* even-numbered harmonics, only odd-numbered. If the duty cycle is below or above 50%, the waveform will *not* exhibit this symmetry, and there will be even-numbered harmonics. The presence of these even-numbered harmonic frequencies can be detected by the human ear, as some of them correspond to *octaves* of the fundamental frequency and thus "fit" more naturally into the tone scheme.

6.10 Class B audio amplifier

PARTS AND MATERIALS

- Four 6 volt batteries
- Dual operational amplifier, model TL082 recommended (Radio Shack catalog # 276-1715)
- One NPN power transistor in a TO-220 package – (Radio Shack catalog # 276-2020 or equivalent)
- One PNP power transistor in a TO-220 package – (Radio Shack catalog # 276-2027 or equivalent)
- One 1N914 switching diode (Radio Shack catalog # 276-1620)
- One capacitor, 47 μF electrolytic, 35 WVDC (Radio Shack catalog # 272-1015 or equivalent)
- Two capacitors, 0.22 μF , non-polarized (Radio Shack catalog # 272-1070)
- One 10 k Ω potentiometer, linear taper (Radio Shack catalog # 271-1715)

Be sure to use an op-amp that has a high *slew rate*. Avoid the LM741 or LM1458 for this reason.

The closer matched the two transistors are, the better. If possible, try to obtain TIP41 and TIP42 transistors, which are closely matched NPN and PNP power transistors with dissipation ratings of 65 watts each. If you cannot get a TIP41 NPN transistor, the TIP3055 (available from Radio Shack) is a good substitute. Do not use very large (i.e. TO-3 case) power transistors, as the op-amp may have trouble driving enough current to their bases for good operation.

CROSS-REFERENCES

Lessons In Electric Circuits, Volume 3, chapter 4: "Bipolar Junction Transistors"

Lessons In Electric Circuits, Volume 3, chapter 8: "Operational Amplifiers"

LEARNING OBJECTIVES

- How to build a "push-pull" class B amplifier using complementary bipolar transistors
- The effects of "crossover distortion" in a push-pull amplifier circuit
- Using negative feedback via an op-amp to correct circuit nonlinearities

SCHEMATIC DIAGRAM

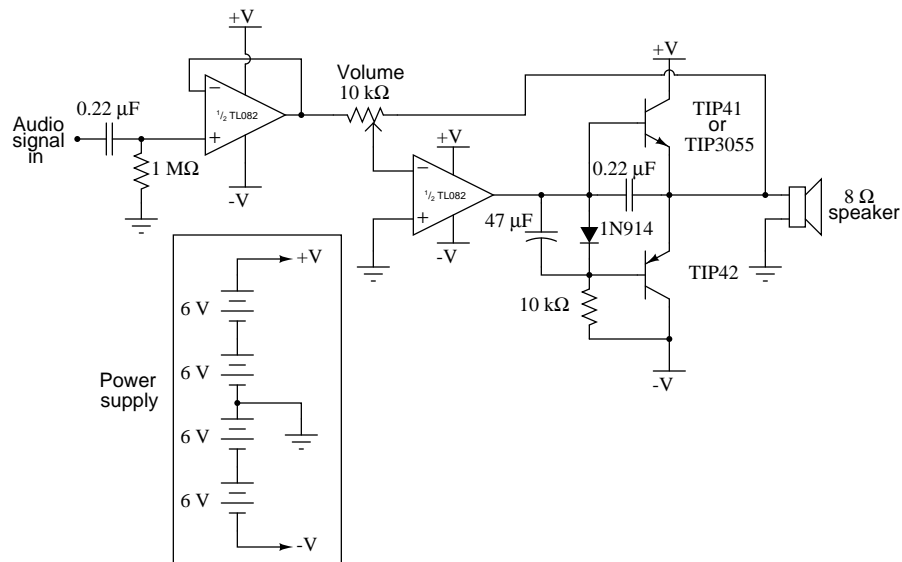

ILLUSTRATION

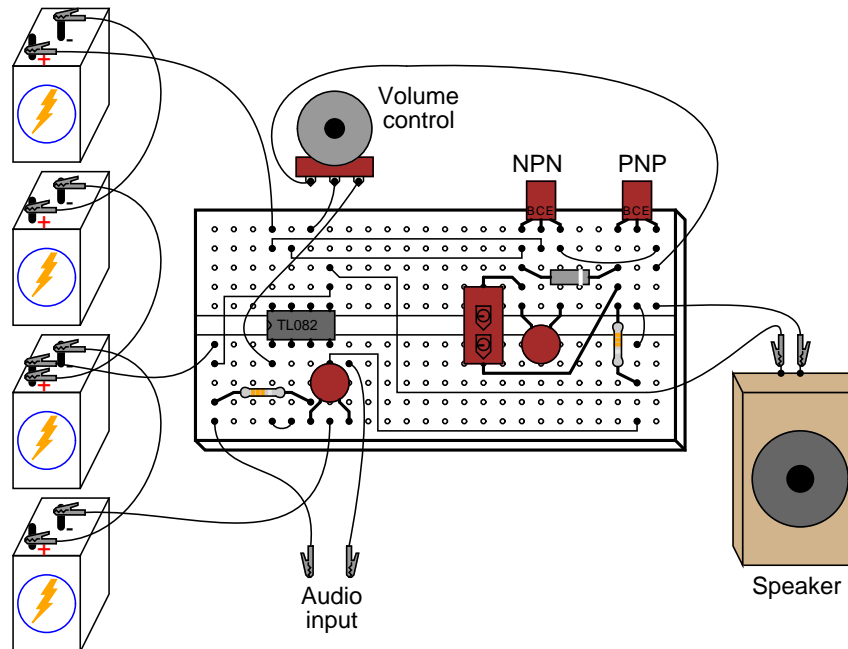

INSTRUCTIONS

This project is an audio amplifier suitable for amplifying the output signal from a small radio, tape player, CD player, or any other source of audio signals. For stereo operation, two

identical amplifiers must be built, one for the left channel and other for the right channel. To obtain an input signal for this amplifier to amplify, just connect it to the output of a radio or other audio device like this:

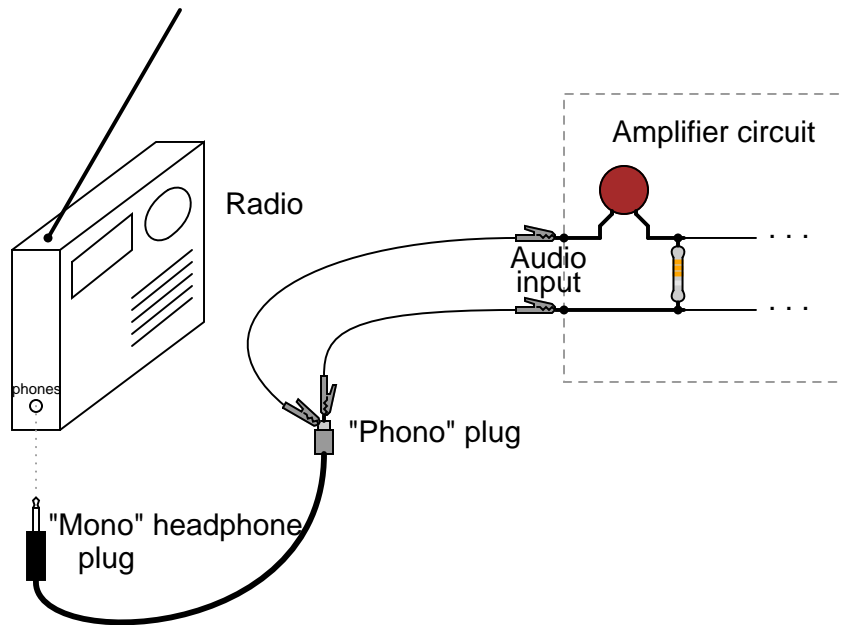

This amplifier circuit also works well in amplifying "line-level" audio signals from high-quality, modular stereo components. It provides a surprising amount of sound power when played through a large speaker, and may be run without heat sinks on the transistors (though you should experiment with it a bit before deciding to forego heat sinks, as the power dissipation varies according to the type of speaker used).

The goal of any amplifier circuit is to reproduce the input waveshape as accurately as possible. Perfect reproduction is impossible, of course, and any differences between the output and input waveshapes is known as *distortion*. In an audio amplifier, distortion may cause unpleasant tones to be superimposed on the true sound. There are many different configurations of audio amplifier circuitry, each with its own advantages and disadvantages. This particular circuit is called a "class B," *push-pull* circuit.

Most audio "power" amplifiers use a class B configuration, where one transistor provides power to the load during one-half of the waveform cycle (it *pushes*) and a second transistor provides power to the load for the other half of the cycle (it *pulls*). In this scheme, neither transistor remains "on" for the entire cycle, giving each one a time to "rest" and cool during the waveform cycle. This makes for a power-efficient amplifier circuit, but leads to a distinct type of nonlinearity known as "crossover distortion."

Shown here is a sine-wave shape, equivalent to a constant audio tone of constant volume:



In a push-pull amplifier circuit, the two transistors take turns amplifying the alternate half-cycles of the waveform like this:

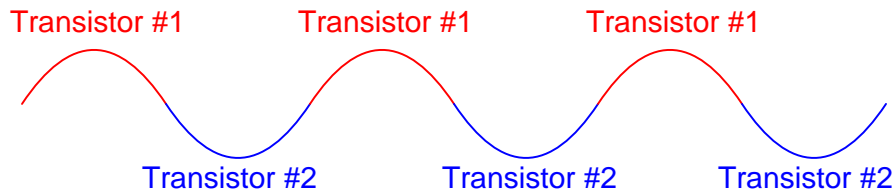

If the "hand-off" between the two transistors is not precisely synchronized, though, the amplifier's output waveform may look something like this instead of a pure sine wave:

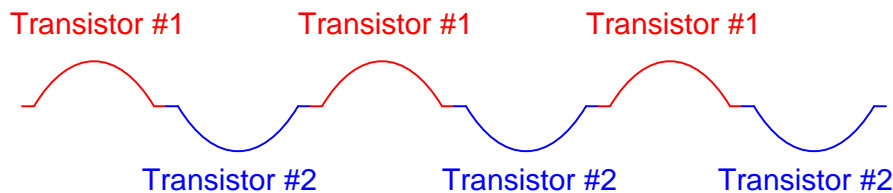

Here, distortion results from the fact that there is a delay between the time one transistor turns off and the other transistor turns on. This type of distortion, where the waveform "flattens" at the crossover point between positive and negative half-cycles, is called *crossover distortion*. One common method of mitigating crossover distortion is to bias the transistors so that their turn-on/turn-off points actually overlap, so that *both* transistors are in a state of conduction for a brief moment during the crossover period:

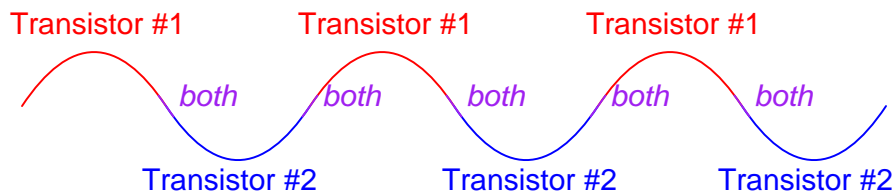

This form of amplification is technically known as class *AB* rather than class B, because each transistor is "on" for more than 50% of the time during a complete waveform cycle. The disadvantage to doing this, though, is increased power consumption of the amplifier circuit, because during the moments of time where both transistors are conducting, there is current conducted through the transistors that is *not* going through the load, but is merely being "shorted" from one power supply rail to the other (from $-V$ to $+V$). Not only is this a waste of energy, but it dissipates more heat energy in the transistors. When transistors increase in temperature, their characteristics change (V_{be} forward voltage drop, β , junction resistances, etc.), making proper biasing difficult.

In this experiment, the transistors operate in pure class B mode. That is, they are never conducting at the same time. This saves energy and decreases heat dissipation, but lends itself to crossover distortion. The solution taken in this circuit is to use an op-amp with negative feedback to quickly drive the transistors through the "dead" zone producing crossover distortion and reduce the amount of "flattening" of the waveform during crossover.

The first (leftmost) op-amp shown in the schematic diagram is nothing more than a buffer. A buffer helps to reduce the loading of the input capacitor/resistor network, which has been placed in the circuit to filter out any DC bias voltage out of the input signal, preventing any DC voltage from becoming amplified by the circuit and sent to the speaker where it might cause damage. Without the buffer op-amp, the capacitor/resistor filtering circuit reduces the low-frequency ("bass") response of the amplifier, and accentuates the high-frequency ("treble").

The second op-amp functions as an inverting amplifier whose gain is controlled by the 10 k Ω potentiometer. This does nothing more than provide a volume control for the amplifier. Usually, inverting op-amp circuits have their feedback resistor(s) connected directly from the op-amp output terminal to the inverting input terminal like this:

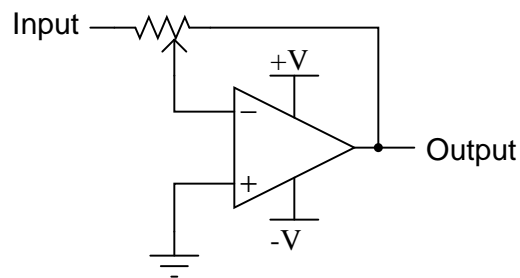

If we were to use the resulting output signal to drive the base terminals of the push-pull transistor pair, though, we would experience significant crossover distortion, because there would be a "dead" zone in the transistors' operation as the base voltage went from +0.7 volts to -0.7 volts:

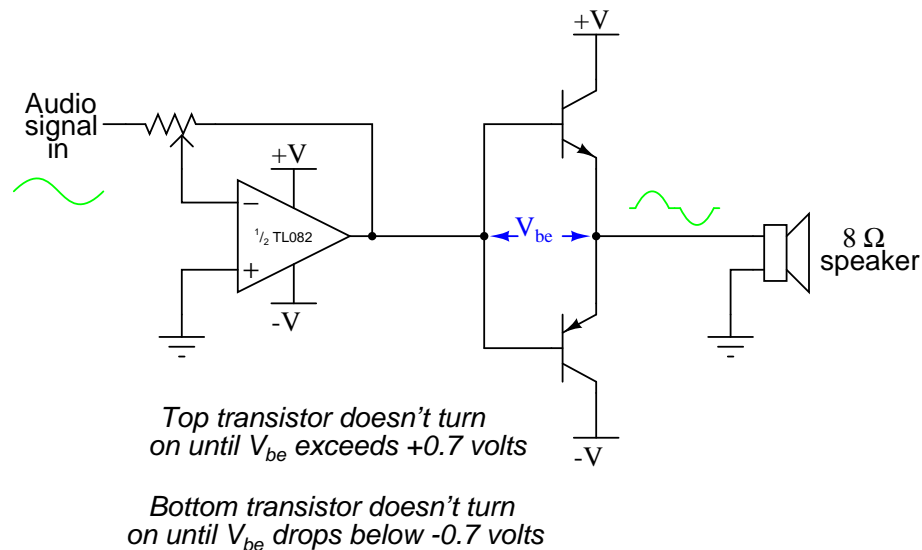

If you have already constructed the amplifier circuit in its final form, you may simplify it to this form and listen to the difference in sound quality. If you have not yet begun construction of the circuit, the schematic diagram shown above would be a good starting point. It will amplify an audio signal, but it will sound horrible!

The reason for the crossover distortion is that when the op-amp output signal is between + 0.7 volts and - 0.7 volts, neither transistor will be conducting, and the output voltage to the speaker will be 0 volts for the entire 1.4 volts span of base voltage swing. Thus, there is a "zone" in the input signal range where no change in speaker output voltage will occur. Here is where intricate biasing techniques are usually introduced to the circuit to reduce this 1.4 volt "gap" in transistor input signal response. Usually, something like this is done:

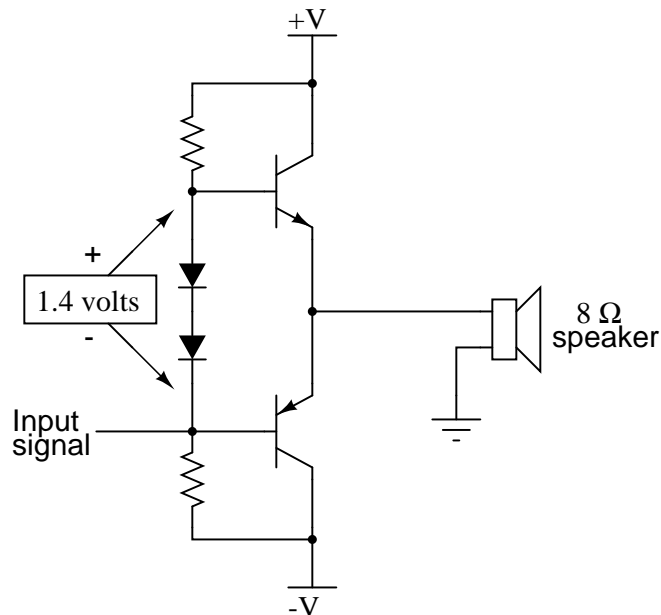

The two series-connected diodes will drop approximately 1.4 volts, equivalent to the combined V_{be} forward voltage drops of the two transistors, resulting in a scenario where each transistor is just on the verge of turning on when the input signal is zero volts, eliminating the 1.4 volt "dead" signal zone that existed before.

Unfortunately, though, this solution is not perfect: as the transistors heat up from conducting power to the load, their V_{be} forward voltage drops will decrease from 0.7 volts to something less, such as 0.6 volts or 0.5 volts. The diodes, which are not subject to the same heating effect because they do not conduct any substantial current, will not experience the same change in forward voltage drop. Thus, the diodes will continue to provide the same 1.4 volt bias voltage even though the transistors require less bias voltage due to heating. The result will be that the circuit drifts into class AB operation, where *both* transistors will be in a state of conduction part of the time. This, of course, will result in more heat dissipation through the transistors, exacerbating the problem of forward voltage drop change.

A common solution to this problem is the insertion of temperature-compensation "feedback" resistors in the emitter legs of the push-pull transistor circuit:

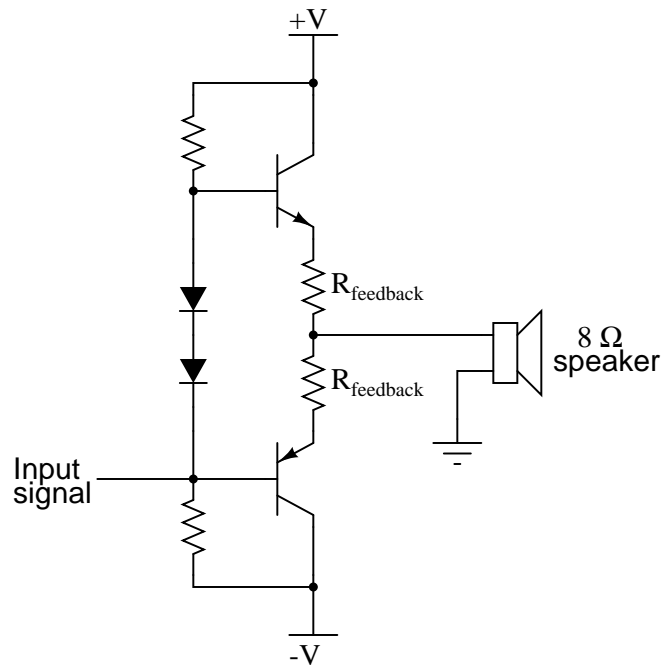

This solution doesn't prevent simultaneous turn-on of the two transistors, but merely reduces the severity of the problem and prevents thermal runaway. It also has the unfortunate effect of inserting resistance in the load current path, limiting the output current of the amplifier. The solution I opted for in this experiment is one that capitalizes on the principle of op-amp negative feedback to overcome the inherent limitations of the push-pull transistor output circuit. I use one diode to provide a 0.7 volt bias voltage for the push-pull pair. This is not enough to eliminate the "dead" signal zone, but it reduces it by at least 50%:

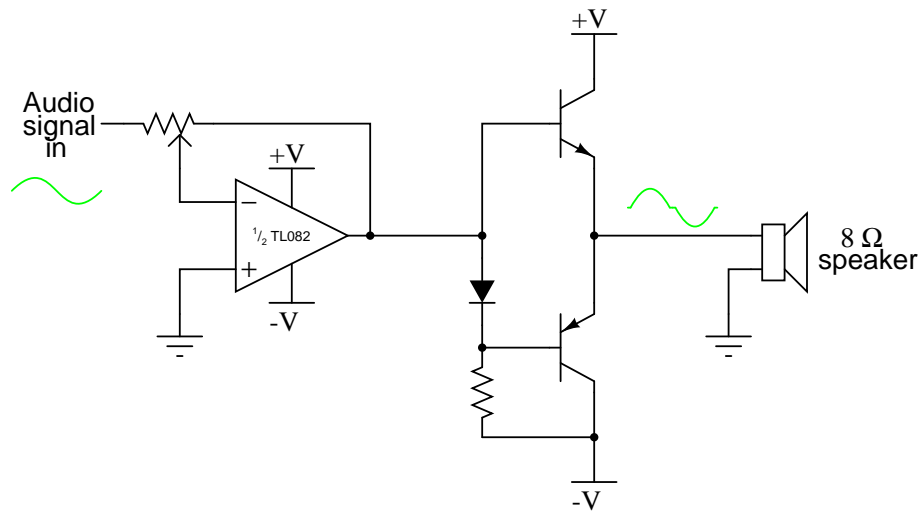

Since the voltage drop of a single diode will always be less than the combined voltage drops of the two transistors' base-emitter junctions, the transistors can never turn on simultaneously, thereby preventing class AB operation. Next, to help get rid of the remaining crossover distortion, the feedback signal of the op-amp is taken from the output terminal of the amplifier (the transistors' emitter terminals) like this:

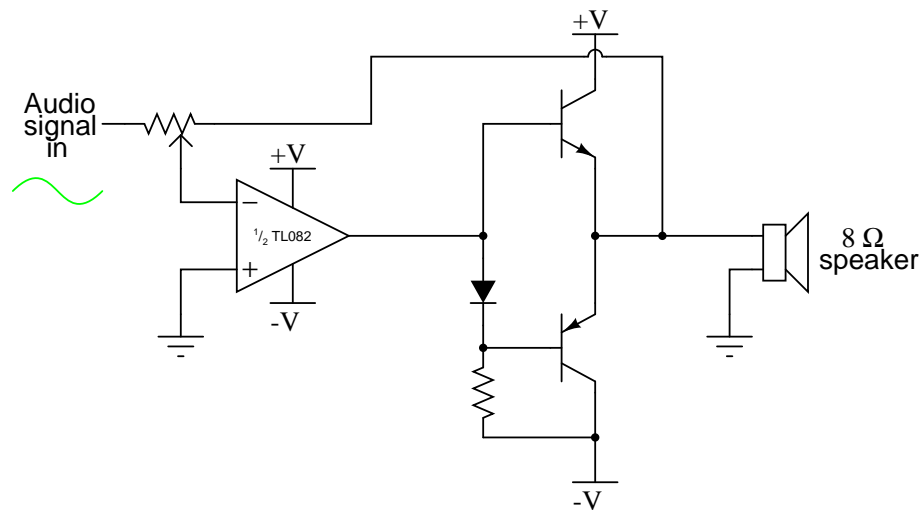

The op-amp's function is to output whatever voltage signal it has to in order to keep its two input terminals at the same voltage (0 volts differential). By connecting the feedback wire to the emitter terminals of the push-pull transistors, the op-amp has the ability to sense any "dead" zone where neither transistor is conducting, and output an appropriate voltage signal to the bases of the transistors to quickly drive them into conduction again to "keep up" with the input signal waveform. This requires an op-amp with a high *slew rate* (the ability to produce a fast-rising or fast-falling output voltage), which is why the TL082 op-amp was specified for this circuit. Slower op-amps such as the LM741 or LM1458 may not be able to keep up with the high dv/dt (voltage rate-of-change over time, also known as de/dt) necessary for low-distortion operation.

Only a couple of capacitors are added to this circuit to bring it into its final form: a 47 μF capacitor connected in parallel with the diode helps to keep the 0.7 volt bias voltage constant despite large voltage swings in the op-amp's output, while a 0.22 μF capacitor connected between the base and emitter of the NPN transistor helps reduce crossover distortion at low volume settings:

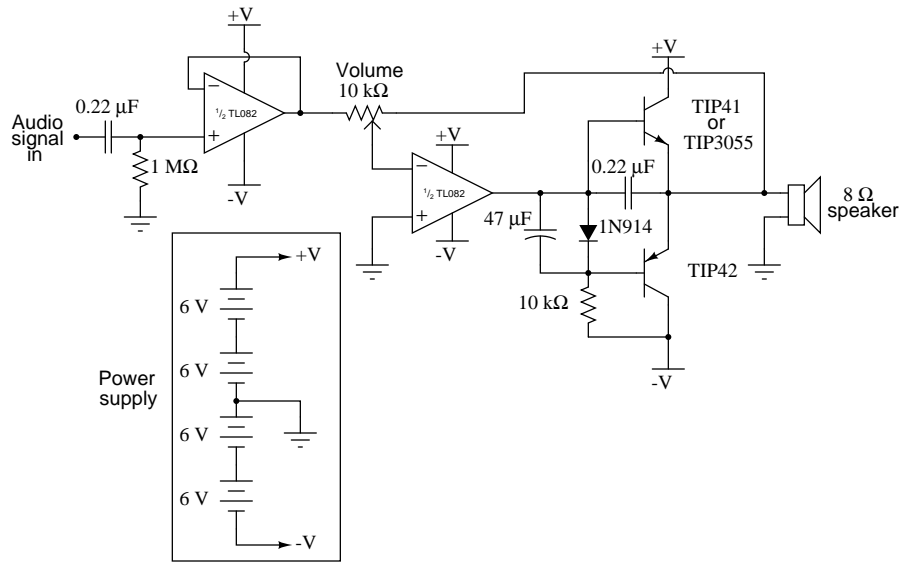

Chapter 7

DIGITAL INTEGRATED CIRCUITS

Contents

7.1 Introduction	329
7.2 Basic gate function	331
7.3 NOR gate S-R latch	335
7.4 NAND gate S-R enabled latch	339
7.5 NAND gate S-R flip-flop	341
7.6 555 Schmitt Trigger	345
7.7 LED sequencer	348
7.8 Simple combination lock	357
7.9 3-bit binary counter	360
7.10 7-segment display	362

7.1 Introduction

Digital circuits are circuits dealing with signals restricted to the extreme limits of zero and some full amount. This stands in contrast to *analog* circuits, in which signals are free to vary continuously between the limits imposed by power supply voltage and circuit resistances. These circuits find use in "true/false" logical operations and digital computation.

The circuits in this chapter make use of *IC*, or *integrated circuit*, components. Such components are actually networks of interconnected components manufactured on a single wafer of semiconducting material. Integrated circuits providing a multitude of pre-engineered functions are available at very low cost, benefitting students, hobbyists and professional circuit designers alike. Most integrated circuits provide the same functionality as "discrete" semiconductor circuits at higher levels of reliability and at a fraction of the cost.

Circuits in this chapter will primarily use *CMOS* technology, as this form of IC design allows for a broad range of power supply voltage while maintaining generally low power consumption levels. Though CMOS circuitry is susceptible to damage from static electricity (high voltages will puncture the insulating barriers in the MOSFET transistors), modern CMOS ICs are far more tolerant of electrostatic discharge than the CMOS ICs of the past, reducing the risk of chip failure by mishandling. Proper handling of CMOS involves the use of anti-static foam for storage and transport of IC's, and measures to prevent static charge from building up on your body (use of a grounding wrist strap, or frequently touching a grounded object).

Circuits using *TTL* technology require a regulated power supply voltage of 5 volts, and will not tolerate any substantial deviation from this voltage level. Any TTL circuits in this chapter will be adequately labeled as such, and it will be expected that you realize its unique power supply requirements.

When building digital circuits using integrated circuit "chips," it is highly recommended that you use a breadboard with power supply "rail" connections along the length. These are sets of holes in the breadboard that are electrically common along the entire length of the board. Connect one to the positive terminal of a battery, and the other to the negative terminal, and DC power will be available to any area of the breadboard via connection through short jumper wires:

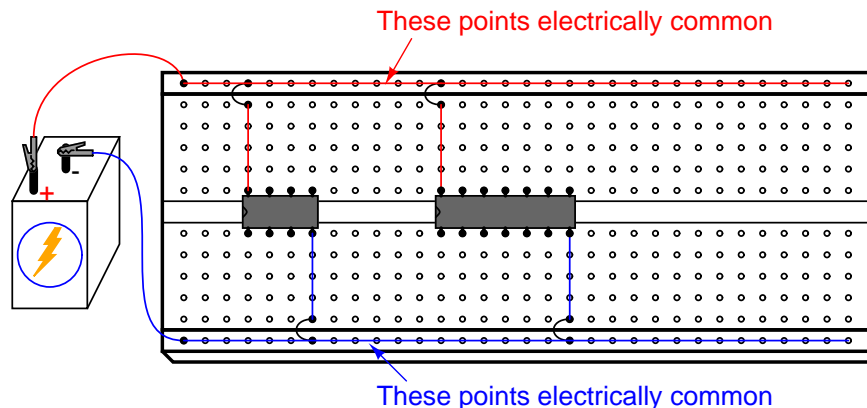

With so many of these integrated circuits having "reset," "enable," and "disable" terminals needing to be maintained in a "high" or "low" state, not to mention the V_{DD} (or V_{CC}) and ground power terminals which require connection to the power supply, having both terminals of the power supply readily available for connection at any point along the board's length is very useful.

Most breadboards that I have seen have these power supply "rail" holes, but some do not. Up until this point, I've been illustrating circuits using a breadboard lacking this feature, just to show how it isn't absolutely necessary. However, digital circuits seem to require more connections to the power supply than other types of breadboard circuits, making this feature more than just a convenience.

7.2 Basic gate function

PARTS AND MATERIALS

- 4011 quad NAND gate (Radio Shack catalog # 276-2411)
- Eight-position DIP switch (Radio Shack catalog # 275-1301)
- Ten-segment bargraph LED (Radio Shack catalog # 276-081)
- One 6 volt battery
- Two 10 k Ω resistors
- Three 470 Ω resistors

Caution! The 4011 IC is CMOS, and therefore sensitive to static electricity!

CROSS-REFERENCES

Lessons In Electric Circuits, Volume 4, chapter 3: "Logic Gates"

LEARNING OBJECTIVES

- Purpose of a "pulldown" resistor
- How to experimentally determine the truth table of a gate
- How to connect logic gates together
- How to create different logical functions by using NAND gates

SCHEMATIC DIAGRAM

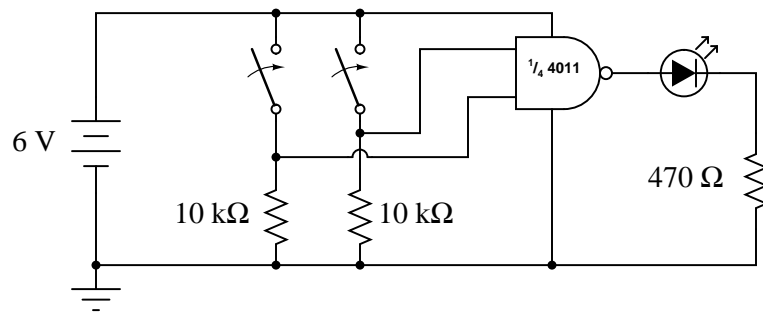

ILLUSTRATION

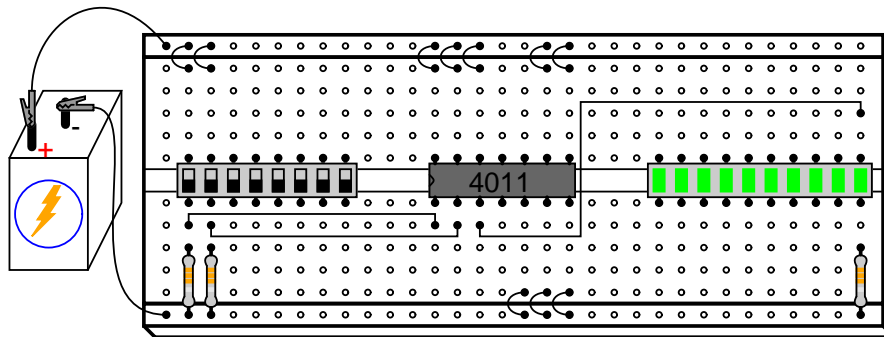

INSTRUCTIONS

To begin, connect a single NAND gate to two input switches and one LED, as shown. At first, the use of an 8-position switch and a 10-segment LED bargraph may seem excessive, since only two switches and one LED are needed to show the operation of a single NAND gate. However, the presence of those extra switches and LEDs make it very convenient to expand the circuit, and help make the circuit layout both clean and compact.

It is highly recommended that you have a datasheet for the 4011 chip available when you build your circuit. Don't just follow the illustration shown above! It is important that you develop the skill of reading datasheets, especially "pinout" diagrams, when connecting IC terminals to other circuit elements. The datasheet's connection diagram is an essential piece of information to have. Shown here is my own rendition of what any 4011 datasheet shows:

"Pinout," or "connection" diagram for the 4011 quad NAND gate

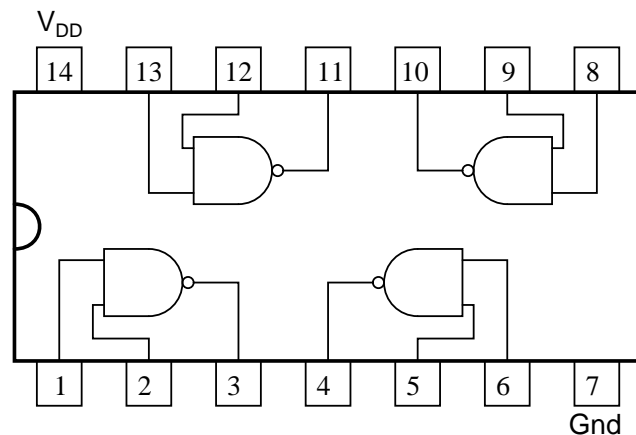

In the breadboard illustration, I've shown the circuit built using the lower-left NAND gate: pin #'s 1 and 2 are the inputs, and pin #3 is the output. Pin #'s 14 and 7 conduct DC power to all four gate circuits inside the IC chip, " V_{DD} " representing the positive side of the power supply (+V), and "Gnd" representing the negative side of the power supply (-V), or ground. Sometimes the negative power supply terminal will be labeled " V_{SS} " instead of "Gnd" on a datasheet, but it means the same thing.

Digital logic circuitry does not make use of split power supplies as op-amps do. Like op-amp circuits, though, ground is still the implicit point of reference for all voltage measurements. If I were to speak of a "high" signal being present on a certain pin of the chip, I would mean that there was full voltage between that pin and the negative side of the power supply (ground).

Note how all inputs of the unused gates inside the 4011 chip are connected either to V_{DD} or ground. This is not a mistake, but an act of intentional design. Since the 4011 is a CMOS integrated circuit, and CMOS circuit inputs left unconnected (*floating*) can assume any voltage level merely from intercepting a static electric charge from a nearby object, leaving inputs floating means that those unused gates may receive any random combinations of "high" and "low" signals.

Why is this undesirable, if we aren't using those gates? Who cares what signals they receive, if we are not doing anything with their outputs? The problem is, if static voltage signals appear at the gate inputs that are not fully "high" or fully "low," the gates' internal transistors may begin to turn on in such a way as to draw excessive current. At worst, this could lead to damage of the chip. At best it means excessive power consumption. It matters little if we choose to connect these unused gate inputs "high" (V_{DD}) or "low" (ground), so long as we connect them to one of those two places. In the breadboard illustration, I show all the top inputs connected to V_{DD} , and all the bottom inputs (of the unused gates) connected to ground. This was done merely because those power supply rail holes were closer and did not require long jumper wires!

Please note that none of the unused gate *outputs* have been connected to V_{DD} or ground, and for good reason! If I were to do that, I may be forcing a gate to assume the opposite output state that its trying to achieve, which is a complicated way of saying that I would have created a short-circuit. Imagine a gate that is supposed to output a "high" logic level (for a NAND gate, this would be true if any of its inputs were "low"). If such a gate were to have its output terminal directly connected to ground, it could never reach a "high" state (being made electrically common to ground through the jumper wire connection). Instead, its upper (P-channel) output transistor would be turned on in vain, sourcing maximum current to a nonexistent load. This would very likely damage the gate! Gate output terminals, by their very nature, generate their own logic levels and never "float" in the same way that CMOS gate inputs do.

The two 10 k Ω resistors are placed in the circuit to avoid floating input conditions on the used gate. With a switch closed, the respective input will be directly connected to V_{DD} and therefore be "high." With a switch open, the 10 k Ω "pull-down" resistor provides a resistive connection to ground, ensuring a secure "low" state at the gate's input terminal. This way, the input will not be susceptible to stray static voltages.

With the NAND gate connected to the two switches and one LED as shown, you are ready to develop a "truth table" for the NAND gate. Even if you already know what a NAND gate truth table looks like, this is a good exercise in experimentation: discovering a circuit's behavioral principles by induction. Draw a truth table on a piece of paper like this:

A	B	Output
0	0	
0	1	
1	0	
1	1	

The "A" and "B" columns represent the two input switches, respectively. When the switch is on, its state is "high" or 1. When the switch is off, its state is "low," or 0, as ensured by its pulldown resistor. The gate's output, of course, is represented by the LED: whether it is lit (1) or unlit (0). After placing the switches in every possible combination of states and recording the LED's status, compare the resulting truth table with what a NAND gate's truth table should be.

As you can imagine, this breadboard circuit is not limited to testing NAND gates. Any gate type may be tested with two switches, two pulldown resistors, and an LED to indicate output status. Just be sure to double-check the chip's "pinout" diagram before substituting it pin-for-pin in place of the 4011. Not all "quad" gate chips have the same pin assignments!

An improvement you might want to make to this circuit is to assign a couple of LEDs to indicate input status, in addition to the one LED assigned to indicate the output. This makes operation a little more interesting to observe, and has the further benefit of indicating if a switch fails to close (or open) by showing the *true* input signal to the gate, rather than forcing you to infer input status from switch position:

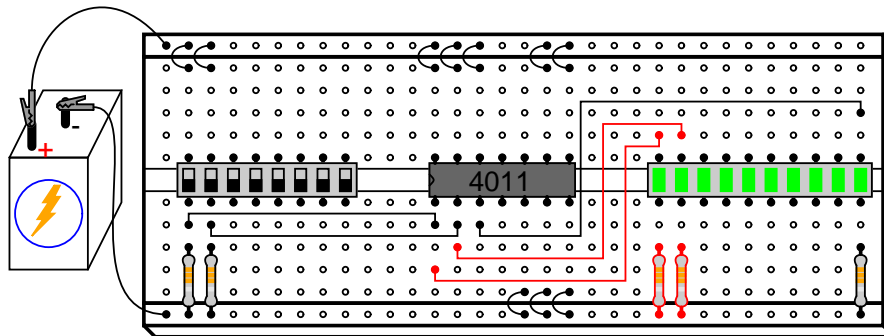

7.3 NOR gate S-R latch

PARTS AND MATERIALS

- 4001 quad NOR gate (Radio Shack catalog # 276-2401)
- Eight-position DIP switch (Radio Shack catalog # 275-1301)
- Ten-segment bargraph LED (Radio Shack catalog # 276-081)
- One 6 volt battery
- Two 10 k Ω resistors
- Two 470 Ω resistors
- Two 100 Ω resistors

Caution! The 4001 IC is CMOS, and therefore sensitive to static electricity!

CROSS-REFERENCES

Lessons In Electric Circuits, Volume 4, chapter 3: "Logic Gates"

Lessons In Electric Circuits, Volume 4, chapter 10: "Multivibrators"

LEARNING OBJECTIVES

- The effects of positive feedback in a digital circuit
- What is meant by the "invalid" state of a latch circuit
- What a *race condition* is in a digital circuit
- The importance of valid "high" CMOS signal voltage levels

SCHEMATIC DIAGRAM

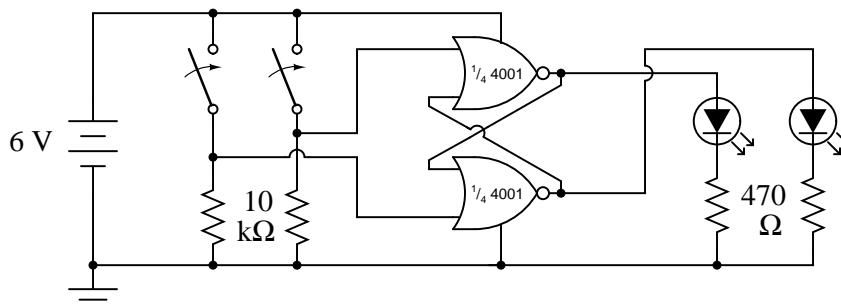

ILLUSTRATION

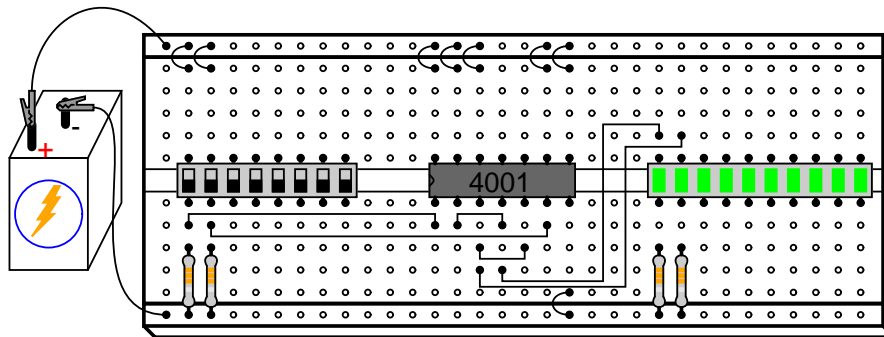

INSTRUCTIONS

The 4001 integrated circuit is a CMOS quad NOR gate, identical in input, output, and power supply pin assignments to the 4011 quad NAND gate. Its "pinout," or "connection," diagram is as such:

"Pinout," or "connection" diagram for the 4001 quad NOR gate

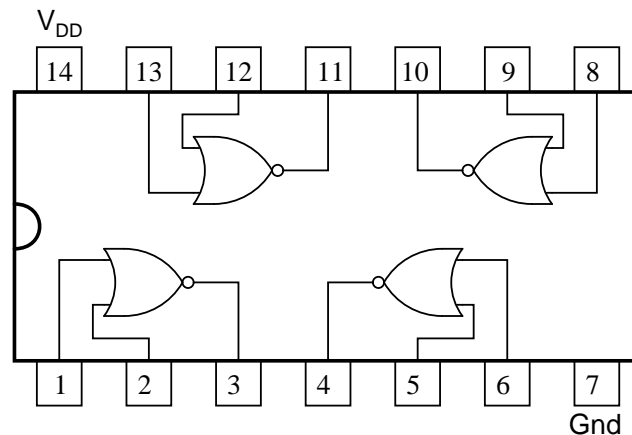

When two NOR gates are cross-connected as shown in the schematic diagram, there will be positive feedback from output to input. That is, the output signal tends to maintain the gate in its last output state. Just as in op-amp circuits, positive feedback creates *hysteresis*. This tendency for the circuit to remain in its last output state gives it a sort of "memory." In fact, there are solid-state computer memory technologies based on circuitry like this!

If we designate the left switch as the "Set" input and the right switch as the "Reset," the left LED will be the "Q" output and the right LED the "Q-not" output. With the Set input "high" (switch on) and the Reset input "low," Q will go "high" and Q-not will go "low." This is known as the *set* state of the circuit. Making the Reset input "high" and the Set input "low" reverses the latch circuit's output state: Q "low" and Q-not "high." This is known as the *reset* state of the circuit. If both inputs are placed into the "low" state, the circuit's Q and Q-not outputs will remain in their last states, "remembering" their prior settings. This is known as the *latched* state of the circuit.

Because the outputs have been designated "Q" and "Q-not," it is implied that their states will always be complementary (opposite). Thus, if something were to happen that forced both outputs to the *same* state, we would be inclined to call that mode of the circuit "invalid." This is exactly what will happen if we make both Set and Reset inputs "high:" both Q and Q-not outputs will be forced to the same "low" logic state. This is known as the *invalid* or *illegal* state of the circuit, not because something has gone wrong, but because the outputs have failed to meet the expectations established by their labels.

Since the "latched" state is a hysteretic condition whereby the last output states are "remembered," one might wonder what will happen if the circuit powers up this way, with *no previous state to hold*. To experiment, place both switches in their off positions, making both Set and Reset inputs low, then disconnect one of the battery wires from the breadboard. Then, quickly make and break contact between that battery wire and its proper connection point on the breadboard, noting the status of the two LEDs as the circuit is powered up again and again:

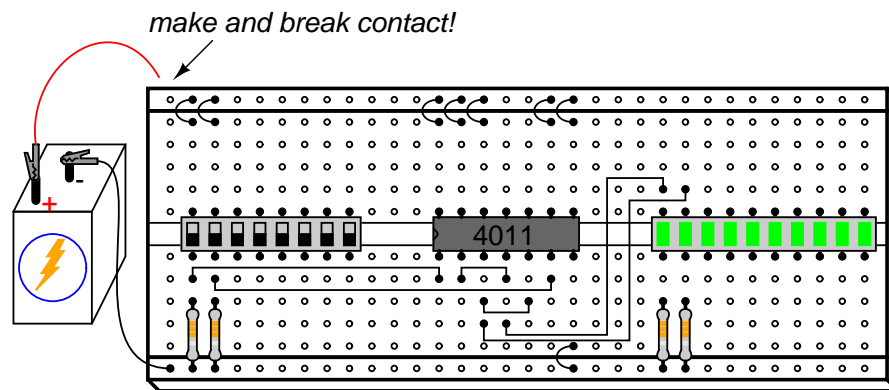

When a latch circuit such as this is powered up into its "latched" state, the gates race against each other for control. Given the "low" inputs, both gates try to output "high" signals. If one of the gates reaches its "high" output state before the other, that "high" state will be fed back to the other gate's input to force its output "low," and the race is won by the faster gate.

Invariably, one gate wins the race, due to internal variations between gates in the chip, and/or external resistances and capacitances that act to delay one gate more than the other. What this usually means is that the circuit tends to power up in the same mode, over and over again. However, if you are persistent in your powering/unpowering cycles, you should see at least a few times where the latch circuit powers up latched in the *opposite* state from normal.

Race conditions are generally undesirable in any kind of system, as they lead to unpredictable operation. They can be particularly troublesome to locate, as this experiment shows, because of the unpredictability they create. Imagine a scenario, for instance, where one of the two NOR gates was exceptionally slow-acting, due to a defect in the chip. This handicap would cause the other gate to win the power-up race every time. In other words, the circuit will be very predictable on power-up with both inputs "low." However, suppose that the unusual chip were to be replaced by one with more evenly matched gates, or by a chip where the *other* NOR gate were consistently slower. Normal circuit behavior is not supposed to change when a component is replaced, but if race conditions are present, a change of components may very well do just that.

Due to the inherent race tendency of an S-R latch, one should not design a circuit with the expectation of a consistent power-up state, but rather use external means to "force" the race so that the desired gate always "wins."

An interesting modification to try in this circuit is to replace one of the 470 Ω LED "dropping" resistors with a lower-value unit, such as 100 Ω . The obvious effect of this alteration will be increased LED brightness, as more current is allowed through. A not-so-obvious effect will also result, and it is this effect which holds great learning value. Try replacing one of the 470 Ω resistors with a 100 Ω resistor, and operate the input signal switches through all four possible setting combinations, noting the behavior of the circuit.

You should note that the circuit refuses to latch in one of its states (either Set or Reset), but only in the other state, when the input switches are both set "low" (the "latch" mode). Why is this? Take a voltmeter and measure the output voltage of the gate whose output is "high" when both inputs are "low." Note this voltage indication, then set the input switches in such a way that the *other* state (either Reset or Set) is forced, and measure the output voltage of the other gate when its output is "high." Note the difference between the two gate output voltage levels, one gate loaded by an LED with a 470 Ω resistor, and the other loaded by an LED with a 100 Ω resistor. The one loaded down by the "heavier" load (100 Ω resistor) will be much less: so much less that this voltage will not be interpreted by the other NOR gate's input as a "high" signal at all as it is fed back! All logic gates have permissible "high" and "low" input signal voltage ranges, and if the voltage of a digital signal falls outside this permissible range, it might not be properly interpreted by the receiving gate. In a latch circuit such as this, which depends on a solid "high" signal fed back from the output of one gate to the input of the other, a "weak" signal will not be able to maintain the positive feedback necessary to keep the circuit latched in one of its states.

This is one reason I favor the use of a voltmeter as a logic "probe" for determining digital signal levels, rather than an actual logic probe with "high" and "low" lights. A logic probe may not indicate the presence of a "weak" signal, whereas a voltmeter definitely will by means of its quantitative indication. This type of problem, common in circuits where different "families" of integrated circuits are mixed (TTL and CMOS, for example), can only be found with test equipment providing quantitative measurements of signal level.

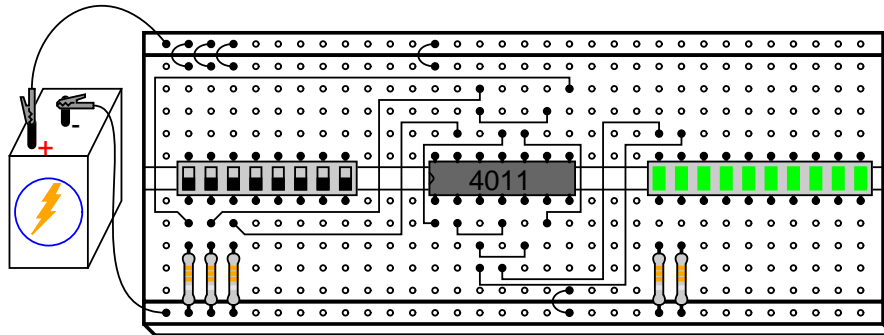

INSTRUCTIONS

Although this circuit uses NAND gates instead of NOR gates, its behavior is identical to that of the NOR gate S-R latch (a "high" Set input drives Q "high," and a "high" Reset input drives Q-not "high"), except for the presence of a third input: the Enable. The purpose of the Enable input is to enable or disable the Set and Reset inputs from having effect over the circuit's output status. When the Enable input is "high," the circuit acts just like the NOR gate S-R latch. When the Enable input is "low," the Set and Reset inputs are disabled and have no effect whatsoever on the outputs, leaving the circuit in its latched state.

This kind of latch circuit (also called a *gated S-R latch*), may be constructed from two NOR gates and two AND gates, but the NAND gate design is easier to build since it makes use of all four gates in a single integrated circuit.

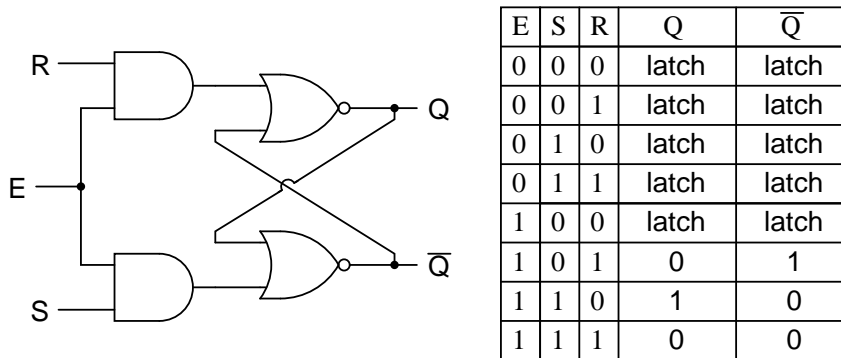

7.5 NAND gate S-R flip-flop

PARTS AND MATERIALS

- 4011 quad NAND gate (Radio Shack catalog # 276-2411)
- 4001 quad NOR gate (Radio Shack catalog # 276-2401)
- Eight-position DIP switch (Radio Shack catalog # 275-1301)
- Ten-segment bargraph LED (Radio Shack catalog # 276-081)
- One 6 volt battery
- Three 10 k Ω resistors
- Two 470 Ω resistors

Caution! The 4011 IC is CMOS, and therefore sensitive to static electricity!

Although the parts list calls for a ten-segment LED unit, the illustration shows two individual LEDs being used instead. This is due to lack of room on my breadboard to mount the switch assembly, two integrated circuits, and the bargraph. If you have room on your breadboard, feel free to use the bargraph as called for in the parts list, and as shown in prior latch circuits.

CROSS-REFERENCES

Lessons In Electric Circuits, Volume 4, chapter 3: "Logic Gates"

Lessons In Electric Circuits, Volume 4, chapter 10: "Multivibrators"

LEARNING OBJECTIVES

- The difference between a gated latch and a flip-flop
- How to build a "pulse detector" circuit
- Learn the effects of switch contact "bounce" on digital circuits

SCHEMATIC DIAGRAM

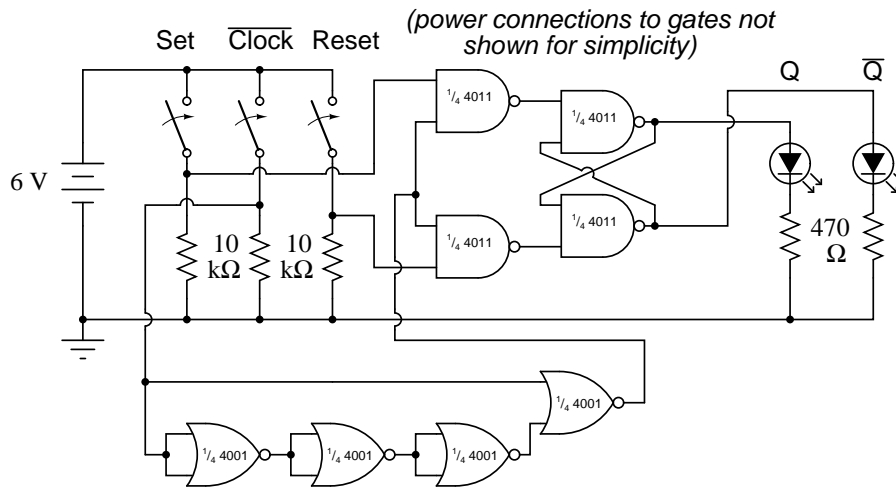

ILLUSTRATION

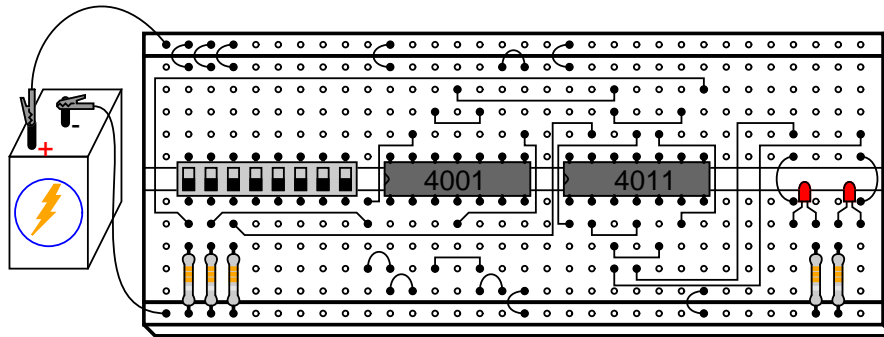

INSTRUCTIONS

The only difference between a *gated* (or *enabled*) latch and a flip-flop is that a flip-flop is enabled only on the rising or falling *edge* of a "clock" signal, rather than for the entire duration of a "high" enable signal. Converting an enabled latch into a flip-flop simply requires that a "pulse detector" circuit be added to the Enable input, so that the edge of a clock pulse generates a brief "high" Enable pulse:

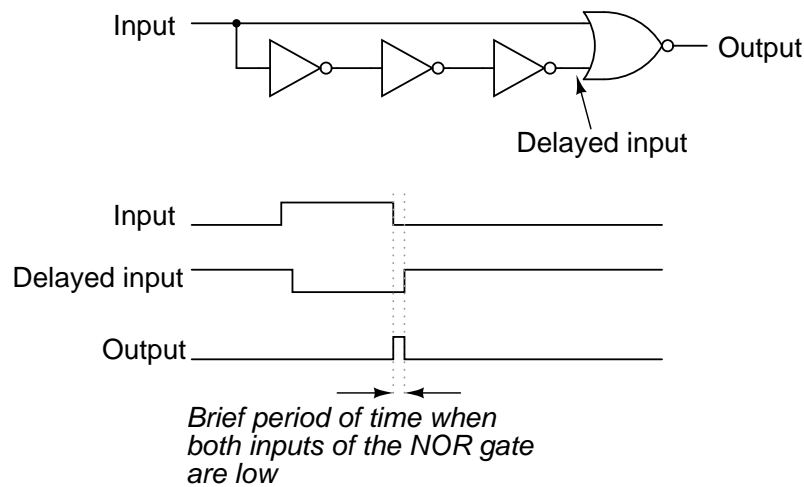

The single NOR gate and three inverter gates create this effect by exploiting the propagation delay time of multiple, cascaded gates. In this experiment, I use three NOR gates with paralleled inputs to create three inverters, thus using all four NOR gates of a 4001 integrated circuit:

Pulse detector circuit

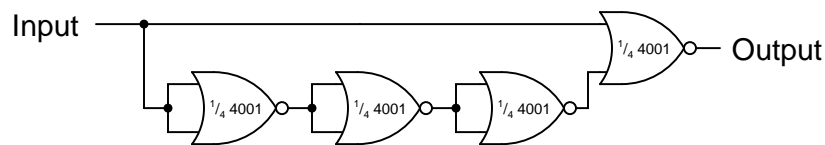

Normally, when using a NOR gate as an inverter, one input would be grounded while the other acts as the inverter input, to minimize input capacitance and increase speed. Here, however, slow response is *desired*, and so I parallel the NOR inputs to make inverters rather than use the more conventional method.

Please note that this particular pulse detector circuit produces a "high" output pulse at every *falling edge* of the clock (input) signal. This means that the flip-flop circuit should be responsive to the Set and Reset input states only when the middle switch is moved from "on" to "off," not from "off" to "on."

When you build this circuit, though, you may discover that the outputs respond to Set and Reset input signals during *both* transitions of the Clock input, not just when it is switched from a "high" state to a "low" state. The reason for this is contact *bounce*: the effect of a mechanical switch rapidly making-and-breaking when its contacts are first closed, due to the elastic collision of the metal contact pads. Instead of the Clock switch producing a single, clean low-to-high signal transition when closed, there will most likely be several low-high-low "cycles" as the contact pads "bounce" upon off-to-on actuation. The first high-to-low transition caused by bouncing will trigger the pulse detector circuit, enabling the S-R latch for that moment in time, making it responsive to the Set and Reset inputs.

Ideally, of course, switches are perfect and bounce-free. In the real world, though, contact bounce is a very common problem for digital gate circuits operated by switch inputs, and must

be understood well if it is to be overcome.

7.6 555 Schmitt Trigger

PARTS AND MATERIALS

- One 9V Battery
- Battery Clip (Radio Shack catalog # 270-325)
- Mini Hook Clips (soldered to Battery Clip, Radio Shack catalog # 270-372)
- One Potentiometer, 10 K Ω , 15-Turn (Radio Shack catalog # 271-343)
- One 555 timer IC (Radio Shack catalog # 276-1723)
- One red light-emitting diode (Radio Shack catalog # 276-041 or equivalent)
- One green light-emitting diode (Radio Shack catalog # 276-022 or equivalent)
- Two 1 K Ω Resistors
- One DVM (Digital Volt Meter) or VOM (Volt Ohm Meter)

CROSS-REFERENCES

Lessons In Electric Circuits, Volume 3, chapter 8: Positive Feedback
Lessons In Electric Circuits, Volume 4, chapter 3: Logic Signal Voltage Levels

LEARNING OBJECTIVES

- Learn how a Schmitt Trigger works
- How to use the 555 timer as an Schmitt Trigger

SCHEMATIC DIAGRAM

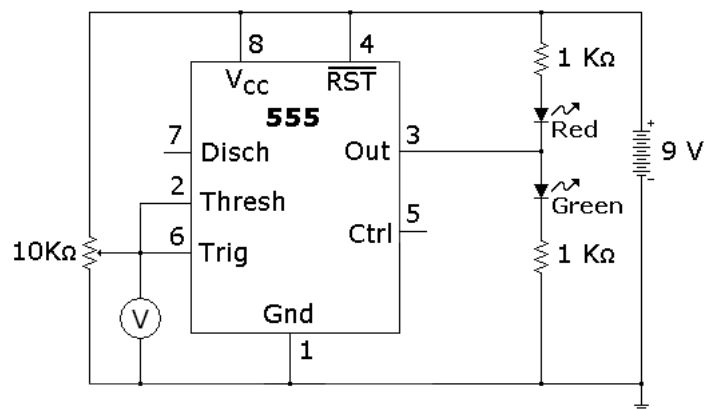

Schmitt Triggers have a convention to show a gate that is also a Schmitt Trigger, shown below.

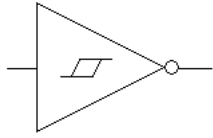

The same schematic redrawn to reflect this convention looks something like this:

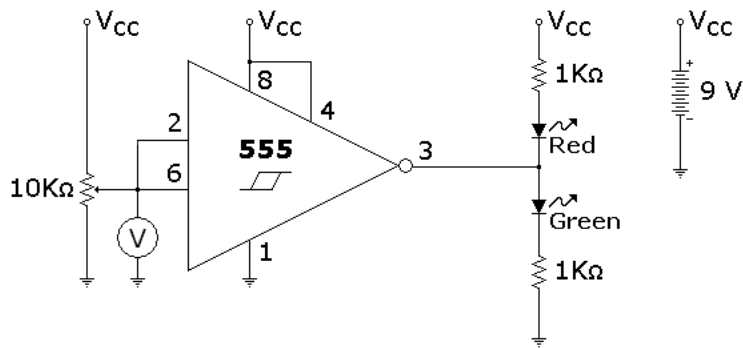

ILLUSTRATION

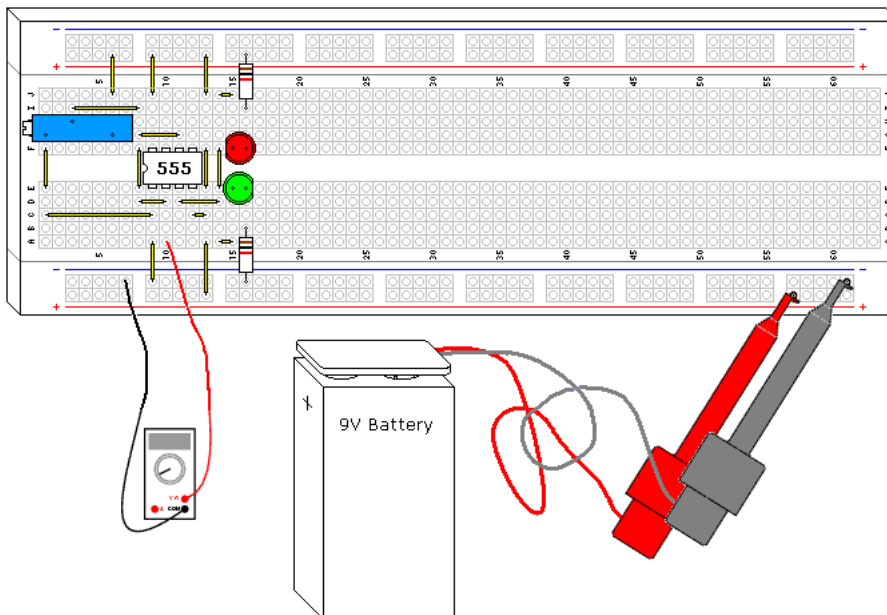

INSTRUCTIONS

The 555 timer is probably one of the more versatile "black box" chips. Its 3 resistor voltage divider, 2 comparators, and built in set reset flip flop are wired to form a Schmitt Trigger in this design. Its interesting to note that the configuration isnt even close to the op amp configuration shown elsewhere, but the end result is identical.

Try adjusting the potentiometer until the lights flip states, then measure the voltage. Compare this voltage to the power supply voltage. Adjust the potentiometer the other way until the LEDs flip states again, and measure the voltage. How close to the 1/3 and 2/3 marks did you get?

Try substituting the 9V battery with a 6 volt battery, or two 6 volt batteries, and see how close the thresholds are to the 1/3 and 2/3 marks.

Schmitt Triggers are a fundamental circuit with several uses. One is signal processing, they can pull digital data out of some extremely noisy environments. Other big uses will be shown in following projects, such as an extremely simple RC oscillator.

THEORY OF OPERATION

The defining characteristic of any Schmitt Trigger is its hysteresis. In this case it is 1/3 and 2/3 of the power supply voltage, defined by the built in resistor voltage divider on the 555. The built in comparators C1 and C2 compare the input voltage to the references provided by the voltage divider and use the comparison to trip the built in flip flop, which drives the output driver, another nice feature of the 555. The 555 can drive up to 200ma off either side of the power supply rail, the output driver creates a very low conduction path to either side of the power supply connections. The circuit "shorts" each side of the LED circuit, leaving the other side to light up.

The 5K Ω resistors are not very accurate. It is interesting to note that IC fabrication doesn't generally allow precision resistors, but the resistors compared to each other are extremely close in value, which is critical to the circuits operation.

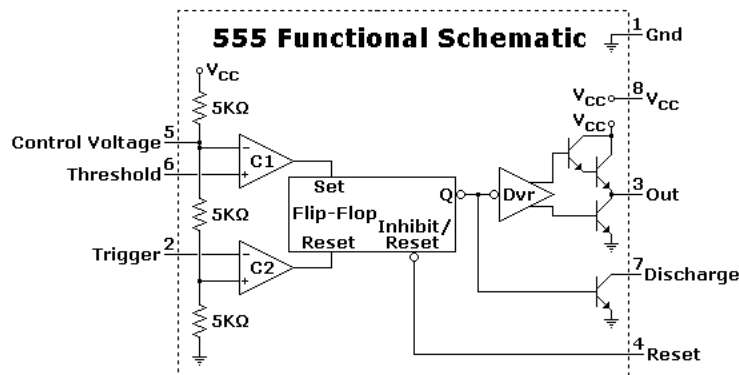

7.7 LED sequencer

PARTS AND MATERIALS

- 4017 decade counter/divider (Radio Shack catalog # 276-2417)
- 555 timer IC (Radio Shack catalog # 276-1723)
- Ten-segment bargraph LED (Radio Shack catalog # 276-081)
- One SPST switch
- One 6 volt battery
- 10 k Ω resistor
- 1 M Ω resistor
- 0.1 μ F capacitor (Radio Shack catalog # 272-135 or equivalent)
- Coupling capacitor, 0.047 to 0.001 μ F
- Ten 470 Ω resistors
- Audio detector with headphones

Caution! The 4017 IC is CMOS, and therefore sensitive to static electricity!

Any single-pole, single-throw switch is adequate. A household light switch will work fine, and is readily available at any hardware store.

The audio detector will be used to assess signal frequency. If you have access to an oscilloscope, the audio detector is unnecessary.

CROSS-REFERENCES

Lessons In Electric Circuits, Volume 4, chapter 3: "Logic Gates"

Lessons In Electric Circuits, Volume 4, chapter 4: "Switches"

Lessons In Electric Circuits, Volume 4, chapter 11: "Counters"

LEARNING OBJECTIVES

- Use of a 555 timer circuit to produce "clock" pulses (*astable* multivibrator)
- Use of a 4017 decade counter/divider circuit to produce a sequence of pulses
- Use of a 4017 decade counter/divider circuit for frequency division
- Using a frequency divider and timepiece (watch) to measure frequency
- Purpose of a "pulldown" resistor
- Learn the effects of switch contact "bounce" on digital circuits
- Use of a 555 timer circuit to "debounce" a mechanical switch (*monostable* multivibrator)

SCHEMATIC DIAGRAM

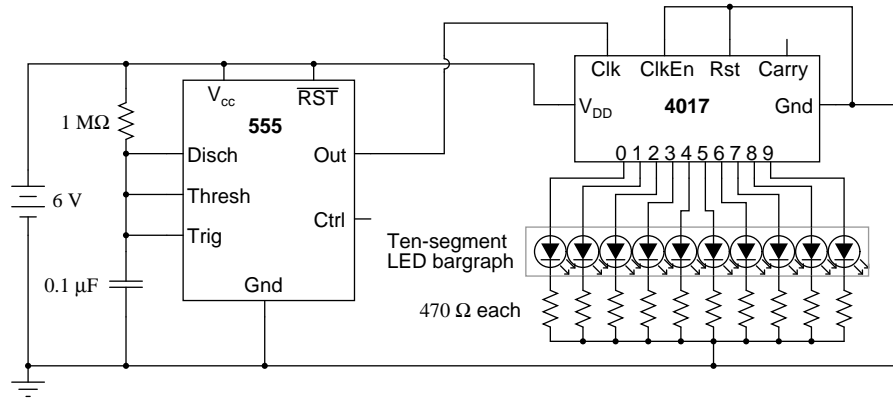

ILLUSTRATION

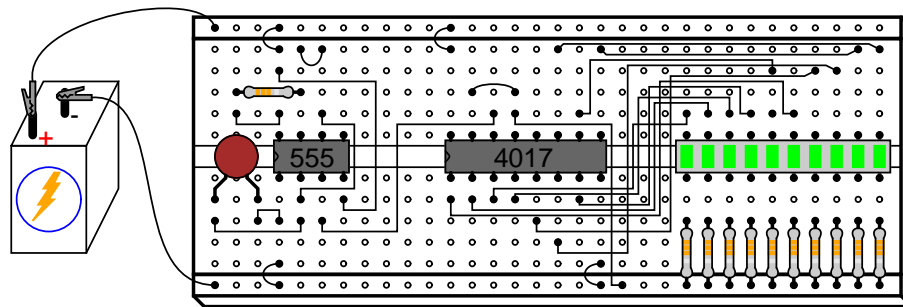

INSTRUCTIONS

The model 4017 integrated circuit is a CMOS counter with ten output terminals. One of these ten terminals will be in a "high" state at any given time, with all others being "low," giving a "one-of-ten" output sequence. If low-to-high voltage pulses are applied to the "clock" (Clk) terminal of the 4017, it will increment its count, forcing the next output into a "high" state.

With a 555 timer connected as an astable multivibrator (oscillator) of low frequency, the 4017 will cycle through its ten-count sequence, lighting up each LED, one at a time, and "recycling" back to the first LED. The result is a visually pleasing sequence of flashing lights. Feel free to experiment with resistor and capacitor values on the 555 timer to create different flash rates.

Try disconnecting the jumper wire leading from the 4017's "Clock" terminal (pin #14) to the 555's "Output" terminal (pin #3) where it connects to the 555 timer chip, and hold its end in your hand. If there is sufficient 60 Hz power-line "noise" around you, the 4017 will detect it as a fast clock signal, causing the LEDs to blink very rapidly.

Two terminals on the 4017 chip, "Reset" and "Clock Enable," are maintained in a "low" state by means of a connection to the negative side of the battery (ground). This is necessary if the chip is to count freely. If the "Reset" terminal is made "high," the 4017's output will be reset

back to 0 (pin #3 "high," all other output pins "low"). If the "Clock Enable" is made "high," the chip will stop responding to the clock signal and pause in its counting sequence.

If the 4017's "Reset" terminal is connected to one of its ten output terminals, its counting sequence will be cut short, or *truncated*. You may experiment with this by disconnecting the "Reset" terminal from ground, then connecting a long jumper wire to the "Reset" terminal for easy connection to the outputs at the ten-segment LED bargraph. Notice how many (or how few) LEDs light up with the "Reset" connected to any one of the outputs:

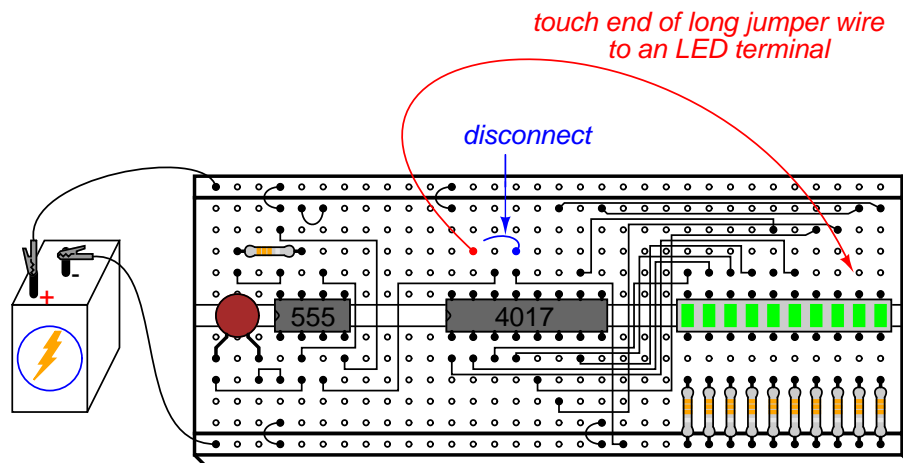

Counters such as the 4017 may be used as digital frequency dividers, to take a clock signal and produce a pulse occurring at some integer factor of the clock frequency. For example, if the clock signal from the 555 timer is 200 Hz, and the 4017 is configured for a full-count sequence (the "Reset" terminal connected to ground, giving a full, ten-step count), a signal with a period ten times as long (20 Hz) will be present at any of the 4017's output terminals. In other words, each output terminal will cycle *once* for every *ten* cycles of the clock signal: a frequency ten times as slow.

To experiment with this principle, connect your audio detector between output 0 (pin #3) of the 4017 and ground, through a very small capacitor (0.047 μF to 0.001 μF). The capacitor is used for "coupling" AC signals only, so that you may audibly detect pulses without placing a DC (resistive) load on the counter chip output. With the 4017 "Reset" terminal grounded, you will have a full-count sequence, and you will hear a "click" in the headphones every time the "0" LED lights up, corresponding to 1/10 of the 555's actual output frequency:

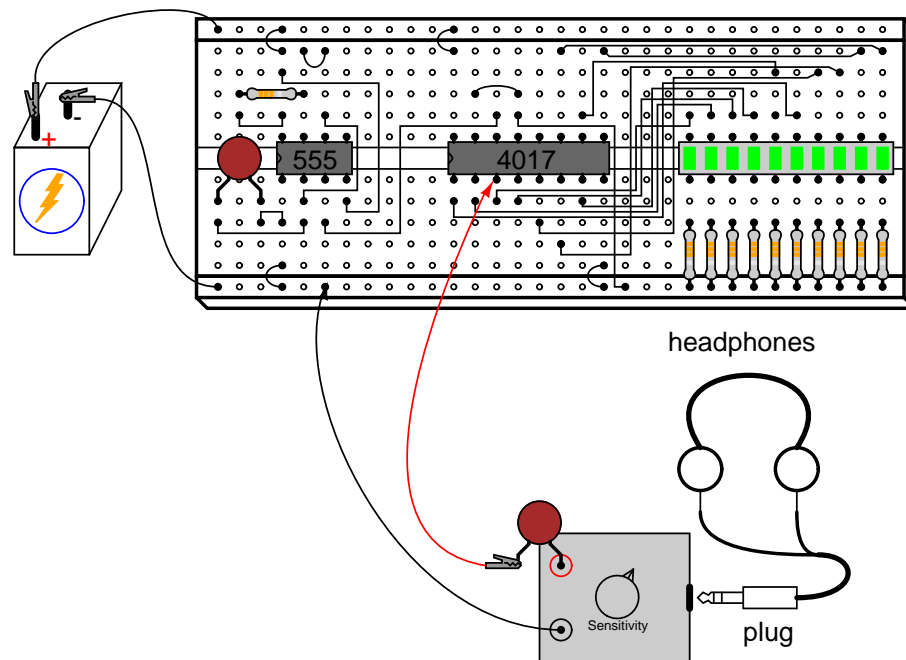

In fact, knowing this mathematical relationship between clicks heard in the headphone and the clock frequency allows us to measure the clock frequency to a fair degree of precision. Using a stopwatch or other timepiece, count the number of clicks heard in one full minute while connected to the 4017's "0" output. Using a $1\text{ M}\Omega$ resistor and $0.1\ \mu\text{F}$ capacitor in the 555 timing circuit, and a power supply voltage of 13 volts (instead of 6), I counted 79 clicks in one minute from my circuit. Your circuit may produce slightly different results. Multiply the number of pulses counted at the "0" output by 10 to obtain the number of cycles produced by the 555 timer during that same time (my circuit: $79 \times 10 = 790$ cycles). Divide this number by 60 to obtain the number of timer cycles elapsed in each second (my circuit: $790/60 = 13.17$). This final figure is the clock frequency in Hz.

Now, leaving one test probe of the audio detector connected to ground, take the other test probe (the one with the coupling capacitor connected in series) and connect it to pin #3 of the 555 timer. The buzzing you hear is the undivided clock frequency:

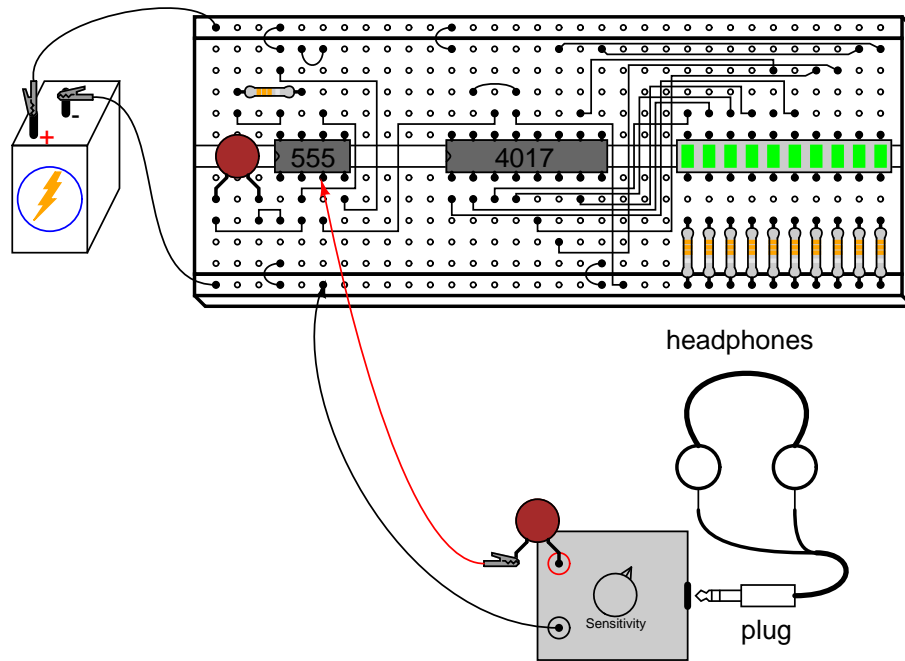

By connecting the 4017's "Reset" terminal to one of the output terminals, a truncated sequence will result. If we are using the 4017 as a frequency divider, this means the output frequency will be a different factor of the clock frequency: $1/9$, $1/8$, $1/7$, $1/6$, $1/5$, $1/4$, $1/3$, or $1/2$, depending on which output terminal we connect the "Reset" jumper wire to. Re-connect the audio detector test probe to output "0" of the 4017 (pin #3), and connect the "Reset" terminal jumper to the sixth LED from the left on the bargraph. This should produce a $1/5$ frequency division ratio:

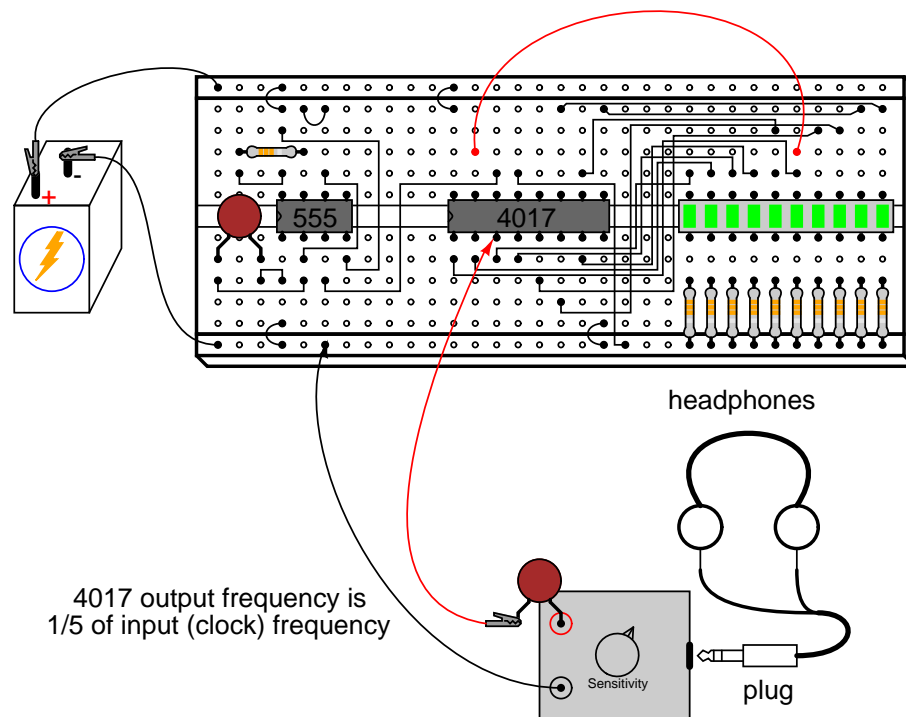

Counting the number of clicks heard in one minute again, you should obtain a number approximately twice as large as what was counted with the 4017 configured for a 1/10 ratio, because 1/5 is twice as large a ratio as 1/10. If you do not obtain a count that is exactly twice what you obtained before, it is because of error inherent to the method of counting cycles: coordinating your sense of hearing with the display of a stopwatch or other time-keeping device.

Try replacing the 1 M Ω timing resistor in the 555 circuit with one of greatly lesser value, such as 10 k Ω . This will increase the clock frequency driving the 4017 chip. Use the audio detector to listen to the divided frequency at pin #3 of the 4017, noting the different tones produced as you move the "Reset" jumper wire to different outputs, creating different frequency division ratios. See if you can produce octaves by dividing the original frequency by 2, then by 4, and then by 8 (each descending octave represents one-half the previous frequency). Octaves are readily distinguished from other divided frequencies by their similar pitches to the original tone.

A final lesson that may be learned from this circuit is that of switch contact "bounce." For this, you will need a switch to provide clock signals to the 4017 chip, instead of the 555 timer. Re-connect the "Reset" jumper wire to ground to enable a full ten-step count sequence, and disconnect the 555's output from the 4017's "Clock" input terminal. Connect a switch in series with a 10 k Ω *pull-down* resistor, and connect this assembly to the 4017 "Clock" input as shown:

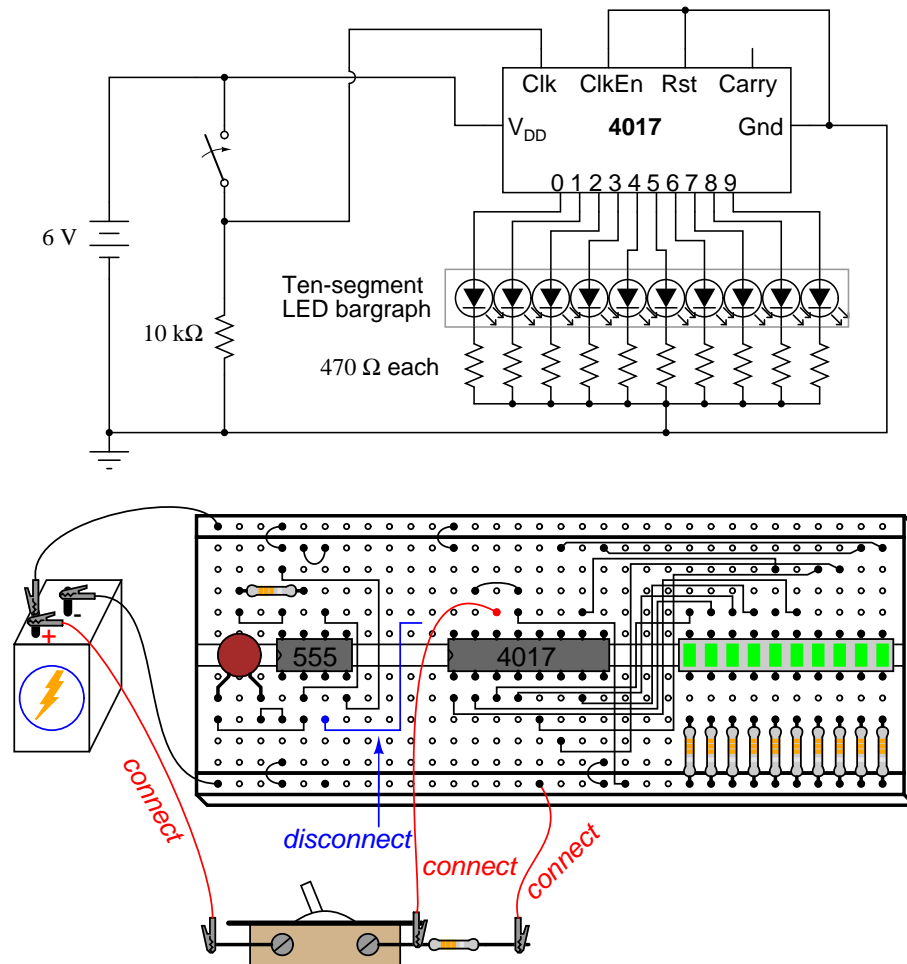

The purpose of a "pull-down" resistor is to provide a definite "low" logic state when the switch contact opens. Without this resistor in place, the 4017's "Clock" input wire would be *floating* whenever the switch contact was opened, leaving it susceptible to interference from stray static voltages or electrical "noise," either one capable of making the 4017 count randomly. With the pull-down resistor in place, the 4017's "Clock" input will have a definite, albeit resistive, connection to ground, providing a stable "low" logic state that precludes any interference from static electricity or "noise" coupled from nearby AC circuit wiring.

Actuate the switch on and off, noting the action of the LEDs. With each off-to-on switch transition, the 4017 should increment once in its count. However, you may notice some strange behavior: sometimes, the LED sequence will "skip" one or even several steps with a single switch closure. Why is this? It is due to very rapid, mechanical "bouncing" of the switch contacts. When two metallic contacts are brought together rapidly as does happen inside most switches, there will be an elastic collision. This collision results in the contacts making and breaking very rapidly as they "bounce" off one another. Normally, this "bouncing" is much too rapid for you to see its effects, but in a digital circuit such as this where the counter chip is able

to respond to very quick clock pulses, these "bounces" are interpreted as distinct clock signals, and the count incremented accordingly.

One way to combat this problem is to use a timing circuit to produce a single pulse for any number of input pulse signals received within a short amount of time. The circuit is called a *monostable multivibrator*, and any technique eliminating the false pulses caused by switch contact "bounce" is called *debouncing*.

The 555 timer circuit is capable of functioning as a debouncer, if the "Trigger" input is connected to the switch as such:

Using the 555 timer to "debounce" the switch

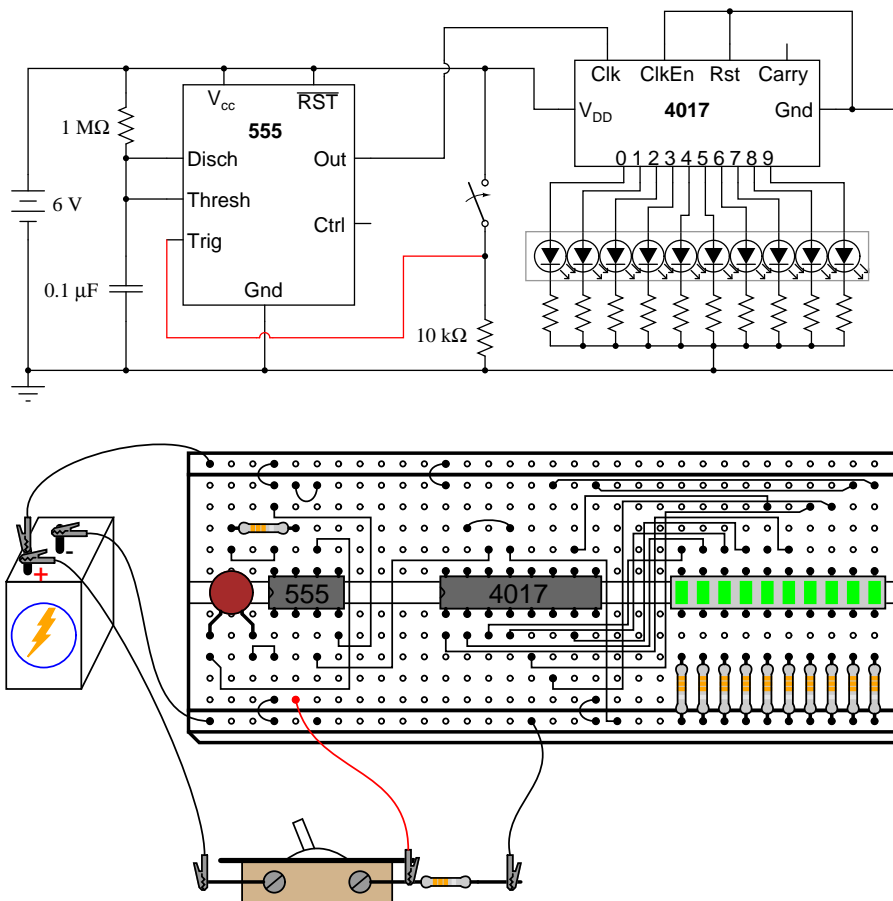

Please note that since we are using the 555 once again to provide a clock signal to the 4017, we must re-connect pin #3 of the 555 chip to pin #14 of the 4017 chip! Also, if you have altered the values of the resistor or capacitor in the 555 timer circuit, you should return to the original 1 MΩ and 0.1 μF components.

Actuate the switch again and note the counting behavior of the 4017. There should be no more "skipped" counts as there were before, because the 555 timer outputs a single, crisp pulse for every *on-to-off* actuation (notice the inversion of operation here!) of the switch. It is

important that the timing of the 555 circuit be appropriate: the time to charge the capacitor should be longer than the "settling" period of the switch (the time required for the contacts to stop bouncing), but not so long that the timer would "miss" a rapid sequence of switch actuations, if they were to occur.

7.8 Simple combination lock

PARTS AND MATERIALS

- 4001 quad NOR gate (Radio Shack catalog # 276-2401)
- 4070 quad XOR gate (Radio Shack catalog # 900-6906)
- Two, eight-position DIP switches (Radio Shack catalog # 275-1301)
- Two light-emitting diodes (Radio Shack catalog # 276-026 or equivalent)
- Four 1N914 "switching" diodes (Radio Shack catalog # 276-1122)
- Ten 10 k Ω resistors
- Two 470 Ω resistors
- Pushbutton switch, normally open (Radio Shack catalog # 275-1556)
- Two 6 volt batteries

Caution! Both the 4001 and 4070 ICs are CMOS, and therefore sensitive to static electricity!

This experiment may be built using only one 8-position DIP switch, but the concept is easier to understand if two switch assemblies are used. The idea is, one switch acts to hold the correct code for unlocking the lock, while the other switch serves as a data entry point for the person trying to open the lock. In real life, of course, the switch assembly with the "key" code set on it must be hidden from the sight of the person opening the lock, which means it must be physically located *elsewhere* from where the data entry switch assembly is. This requires two switch assemblies. However, if you understand this concept clearly, you may build a working circuit with only one 8-position switch, using the left four switches for data entry and the right four switches to hold the "key" code.

For extra effect, choose different colors of LED: green for "Go" and red for "No go."

CROSS-REFERENCES

Lessons In Electric Circuits, Volume 4, chapter 3: "Logic Gates"

LEARNING OBJECTIVES

- Using XOR gates as bit comparators
- How to build simple gate functions with diodes and a pullup/down resistor
- Using NOR gates as controlled inverters

SCHEMATIC DIAGRAM

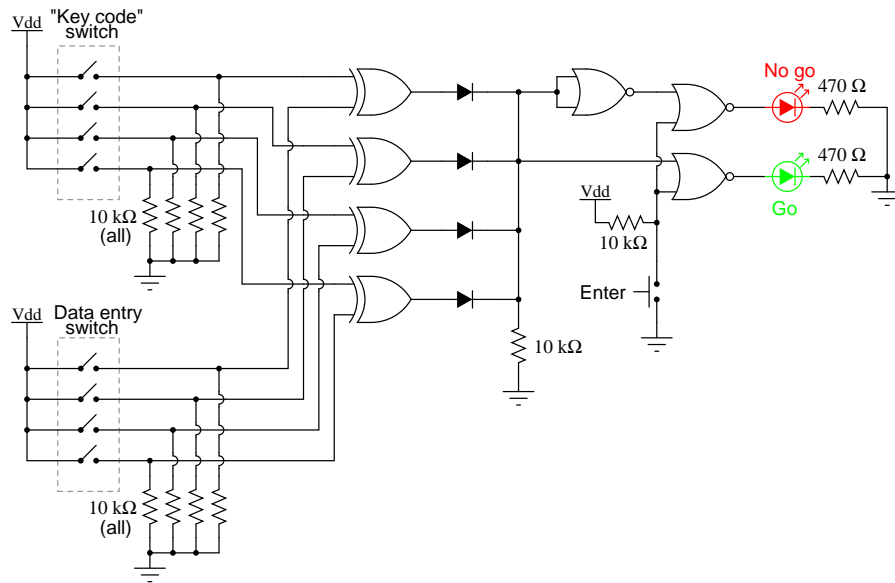

ILLUSTRATION

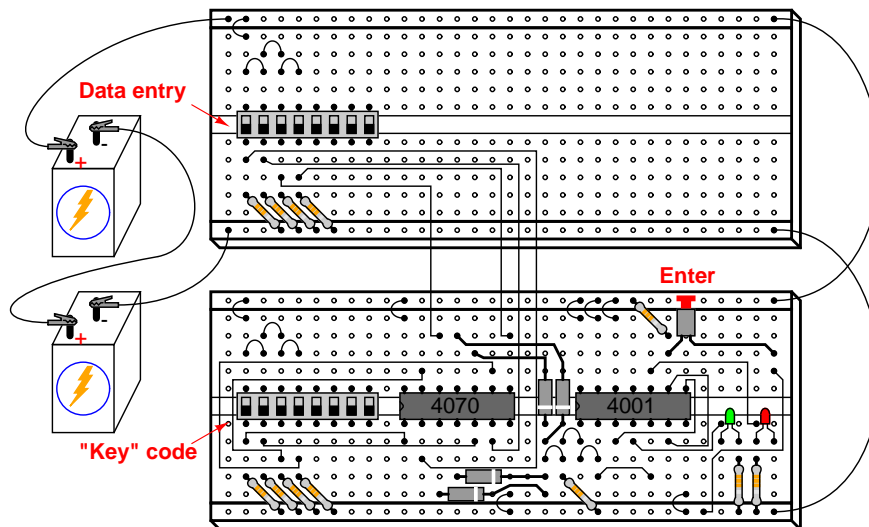

INSTRUCTIONS

This circuit illustrates the use of XOR (Exclusive-OR) gates as bit comparators. Four of these XOR gates compare the respective bits of two 4-bit binary numbers, each number "entered" into the circuit via a set of switches. If the two numbers match, bit for bit, the green "Go" LED will light up when the "Enter" pushbutton switch is pressed. If the two numbers do not exactly match, the red "No go" LED will light up when the "Enter" pushbutton is pressed.

Because four bits provides a mere sixteen possible combinations, this lock circuit is not very sophisticated. If it were used in a real application such as a home security system, the "No go" output would have to be connected to some kind of siren or other alarming device, so that the entry of an incorrect code would deter an unauthorized person from attempting another code entry. Otherwise, it would not take much time to try all combinations (0000 through 1111) until the correct one was found! In this experiment, I do not describe how to work this circuit into a real security system or lock mechanism, but only how to make it recognize a pre-entered code.

The "key" code that must be matched at the data entry switch array should be hidden from view, of course. If this were part of a real security system, the data entry switch assembly would be located *outside* the door, and the key code switch assembly *behind* the door with the rest of the circuitry. In this experiment, you will likely locate the two switch assemblies on two different breadboards, but it is entirely possible to build the circuit using just a single (8-position) DIP switch assembly. Again, the purpose of the experiment is not to make a real security system, but merely to introduce you to the principle of XOR gate code comparison.

It is the nature of an XOR gate to output a "high" (1) signal if the input signals are *not* the same logic state. The four XOR gates' output terminals are connected through a diode network which functions as a four-input OR gate: if *any* of the four XOR gates outputs a "high" signal – indicating that the entered code and the key code are not identical – then a "high" signal will be passed on to the NOR gate logic. If the two 4-bit codes are identical, then none of the XOR gate outputs will be "high," and the pull-down resistor connected to the common sides of the diodes will provide a "low" signal state to the NOR logic.

The NOR gate logic performs a simple task: prevent either of the LEDs from turning on if the "Enter" pushbutton is not pressed. Only when this pushbutton is pressed can either of the LEDs energize. If the Enter switch is pressed and the XOR outputs are all "low," the "Go" LED will light up, indicating that the correct code has been entered. If the Enter switch is pressed and any of the XOR outputs are "high," the "No go" LED will light up, indicating that an incorrect code has been entered. Again, if this were a real security system, it would be wise to have the "No go" output do something that deters an unauthorized person from discovering the correct code by trial-and-error. In other words, there should be some sort of *penalty* for entering an incorrect code. Let your imagination guide your design of this detail!

7.9 3-bit binary counter

PARTS AND MATERIALS

- 555 timer IC (Radio Shack catalog # 276-1723)
- One 1N914 "switching" diode (Radio Shack catalog # 276-1122)
- Two 10 k Ω resistors
- One 100 μ F capacitor (Radio Shack catalog # 272-1028)
- 4027 dual J-K flip-flop (Radio Shack catalog # 900-4394)
- Ten-segment bargraph LED (Radio Shack catalog # 276-081)
- Three 470 Ω resistors
- One 6 volt battery

Caution! The 4027 IC is CMOS, and therefore sensitive to static electricity!

CROSS-REFERENCES

Lessons In Electric Circuits, Volume 4, chapter 10: "Multivibrators"

Lessons In Electric Circuits, Volume 4, chapter 11: "Counters"

LEARNING OBJECTIVES

- Using the 555 timer as a square-wave oscillator
- How to make an asynchronous counter using J-K flip-flops

SCHEMATIC DIAGRAM

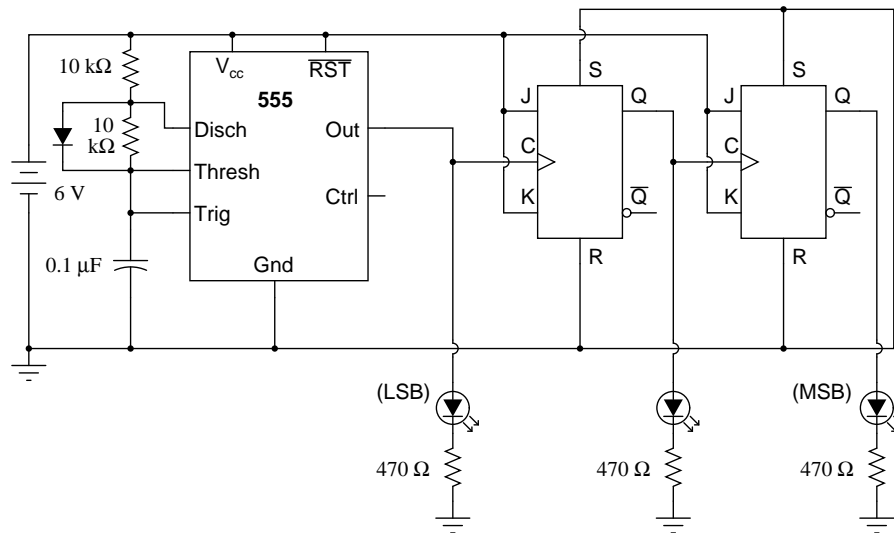

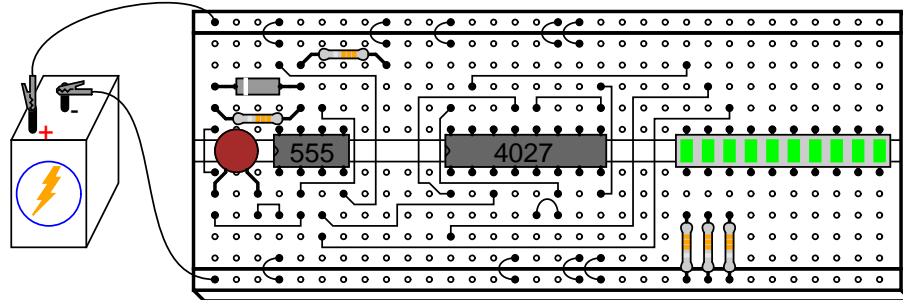
ILLUSTRATION**INSTRUCTIONS**

In a sense, this circuit "cheats" by using only two J-K flip-flops to make a three-bit binary counter. Ordinarily, three flip-flops would be used – one for each binary bit – but in this case we can use the clock pulse (555 timer output) as a bit of its own. When you build this circuit, you will find that it is a "down" counter. That is, its count sequence goes from 111 to 110 to 101 to 100 to 011 to 010 to 001 to 000 and then back to 111. While it is possible to construct an "up" counter using J-K flip-flops, this would require additional components and introduce more complexity into the circuit.

The 555 timer operates as a slow, square-wave oscillator with a duty cycle of approximately 50 percent. This duty cycle is made possible by the use of a diode to "bypass" the lower resistor during the capacitor's charging cycle, so that the charging time constant is only RC and not 2RC as it would be without the diode in place.

It is highly recommended, in this experiment as in all experiments, to build the circuit in stages: identify portions of the circuit with specific functions, and build those portions one at a time, testing each one and verifying its performance before building the next. A very common mistake of new electronics students is to build an entire circuit at once without testing sections of it during the construction process, and then be faced with the possibility of several problems simultaneously when it comes time to finally apply power to it. Remember that a small amount of extra attention paid to detail near the beginning of a project is worth an enormous amount of troubleshooting work near the end! Students who make the mistake of not testing circuit portions before attempting to operate the entire circuit often (falsely) think that the time it would take to test those sections is not worth it, and then spend *days* trying to figure out what the problem(s) might be with their experiment.

Following this philosophy, build the 555 timer circuit first, before even plugging the 4027 IC into the breadboard. Connect the 555's output (pin #3) to the "Least Significant Bit" (LSB) LED, so that you have visual indication of its status. Make sure that the output oscillates in a slow, square-wave pattern (LED is "lit" for about as long as it is "off" in a cycle), and that it is a reliable signal (no erratic behavior, no unexplained pauses). If the 555 timer is not working properly, neither will the rest of the counter circuit! Once the timer circuit has been proven good, proceed to plug the 4027 IC into the breadboard and complete the rest of the necessary connections between it, the 555 timer circuit, and the LED assembly.

7.10 7-segment display

PARTS AND MATERIALS

- 4511 BCD-to-7seg latch/decoder/driver (Radio Shack catalog # 900-4437)
- Common-cathode 7-segment LED display (Radio Shack catalog # 276-075)
- Eight-position DIP switch (Radio Shack catalog # 275-1301)
- Four 10 k Ω resistors
- Seven 470 Ω resistors
- One 6 volt battery

Caution! The 4511 IC is CMOS, and therefore sensitive to static electricity!

CROSS-REFERENCES

Lessons In Electric Circuits, Volume 4, chapter 9: "Combinational Logic Functions"

LEARNING OBJECTIVES

- How to use the 4511 7-segment decoder/display driver IC
- Gain familiarity with the BCD code
- How to use 7-segment LED assemblies to create decimal digit displays
- How to identify and use both "active-low" and "active-high" logic inputs

SCHEMATIC DIAGRAM

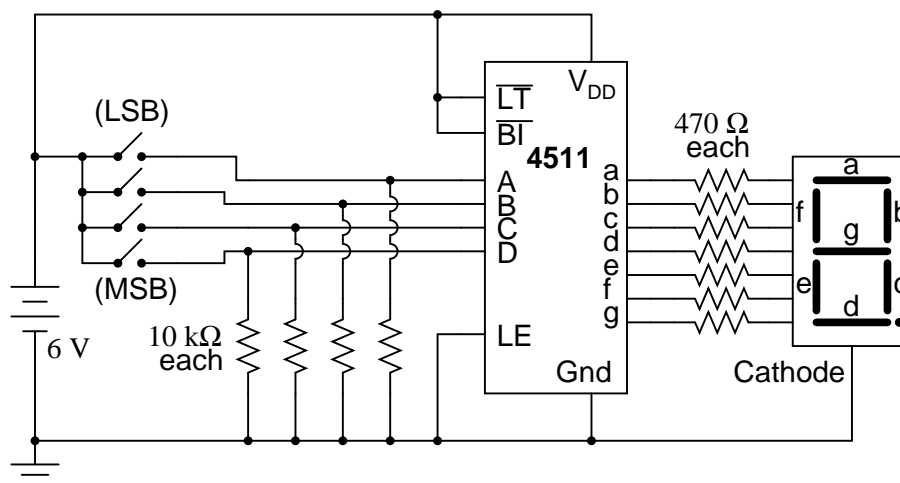

ILLUSTRATION

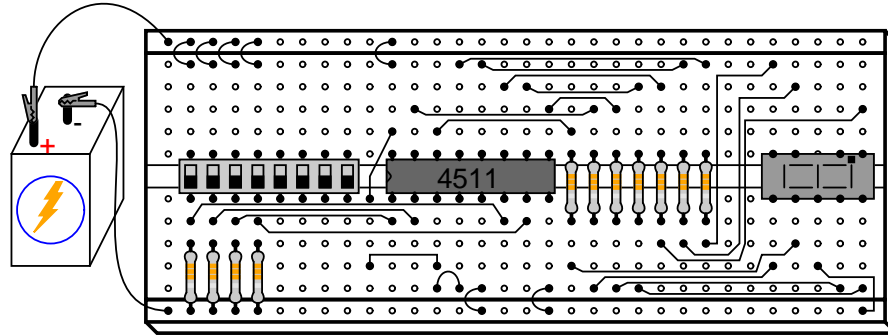

INSTRUCTIONS

This experiment is more of an introduction to the 4511 decoder/display driver IC than it is a lesson in how to “build up” a digital function from lower-level components. Since 7-segment displays are *very* common components of digital devices, it is good to be familiar with the “driving” circuits behind them, and the 4511 is a good example of a typical driver IC.

Its operating principle is to input a four-bit BCD (Binary-Coded Decimal) value, and energize the proper output lines to form the corresponding decimal digit on the 7-segment LED display. The BCD inputs are designated A, B, C, and D in order from least-significant to most-significant. Outputs are labeled a, b, c, d, e, f, and g, each letter corresponding to a standardized segment designation for 7-segment displays. Of course, since each LED segment requires its own dropping resistor, we must use seven $470\ \Omega$ resistors placed in series between the 4511’s output terminals and the corresponding terminals of the display unit.

Most 7-segment displays also provide for a decimal point (sometimes two!), a separate LED and terminal designated for its operation. All LEDs inside the display unit are made common to each other on one side, either cathode or anode. The 4511 display driver IC requires a common-cathode 7-segment display unit, and so that is what is used here.

After building the circuit and applying power, operate the four switches in a binary counting sequence (0000 to 1111), noting the 7-segment display. A 0000 input should result in a decimal “0” display, a 0001 input should result in a decimal “1” display, and so on through 1001 (decimal “9”). What happens for the binary numbers 1010 (10) through 1111 (15)? Read the datasheet on the 4511 IC and see what the manufacturer specifies for operation above an input value of 9. In the BCD code, there is no real meaning for 1010, 1011, 1100, 1101, 1110, or 1111. These are binary values beyond the range of a single decimal digit, and so have no function in a BCD system. The 4511 IC is built to recognize this, and output (or not output!) accordingly.

Three inputs on the 4511 chip have been permanently connected to either V_{dd} or ground: the “Lamp Test,” “Blanking Input,” and “Latch Enable.” To learn what these inputs do, remove the short jumpers connecting them to either power supply rail (one at a time!), and replace the short jumper with a longer one that can reach the *other* power supply rail. For example, remove the short jumper connecting the “Latch Enable” input (pin #5) to ground, and replace it with a long jumper wire that can reach all the way to the V_{dd} power supply rail. Experiment with making this input “high” and “low,” observing the results on the 7-segment display as you alter the BCD code with the four input switches. After you’ve learned what the input’s function

is, connect it to the power supply rail enabling normal operation, and proceed to experiment with the next input (either "Lamp Test" or "Blanking Input").

Once again, the manufacturer's datasheet will be informative as to the purpose of each of these three inputs. Note that the "Lamp Test" (LT) and "Blanking Input" (BI) input labels are written with boolean complementation bars over the abbreviations. Bar symbols designate these inputs as *active-low*, meaning that you must make each one "low" in order to invoke its particular function. Making an active-low input "high" places that particular input into a "passive" state where its function will not be invoked. Conversely, the "Latch Enable" (LE) input has no complementation bar written over its abbreviation, and correspondingly it is shown connected to ground ("low") in the schematic so as to not invoke that function. The "Latch Enable" input is an *active-high* input, which means it must be made "high" (connected to V_{dd}) in order to invoke its function.

Contributors

Contributors to this chapter are listed in chronological order of their contributions, from most recent to first. See Appendix 2 (Contributor List) for dates and contact information.

Bill Marsden (August 2008) Author of "555 Schmitt Trigger" section.

Appendix A-1

ABOUT THIS BOOK

A-1.1 Purpose

They say that necessity is the mother of invention. At least in the case of this book, that adage is true. As an industrial electronics instructor, I was forced to use a sub-standard textbook during my first year of teaching. My students were daily frustrated with the many typographical errors and obscure explanations in this book, having spent much time at home struggling to comprehend the material within. Worse yet were the many incorrect answers in the back of the book to selected problems. Adding insult to injury was the \$100+ price.

Contacting the publisher proved to be an exercise in futility. Even though the particular text I was using had been in print and in popular use for a couple of years, they claimed my complaint was the first they'd ever heard. My request to review the draft for the next edition of their book was met with disinterest on their part, and I resolved to find an alternative text.

Finding a suitable alternative was more difficult than I had imagined. Sure, there were plenty of texts in print, but the really good books seemed a bit too heavy on the math and the less intimidating books omitted a lot of information I felt was important. Some of the best books were out of print, and those that were still being printed were quite expensive.

It was out of frustration that I compiled *Lessons in Electric Circuits* from notes and ideas I had been collecting for years. My primary goal was to put readable, high-quality information into the hands of my students, but a secondary goal was to make the book as affordable as possible. Over the years, I had experienced the benefit of receiving free instruction and encouragement in my pursuit of learning electronics from many people, including several teachers of mine in elementary and high school. Their selfless assistance played a key role in my own studies, paving the way for a rewarding career and fascinating hobby. If only I could extend the gift of their help by giving to other people what they gave to me . . .

So, I decided to make the book freely available. More than that, I decided to make it "open," following the same development model used in the making of free software (most notably the various UNIX utilities released by the Free Software Foundation, and the Linux operating

system, whose fame is growing even as I write). The goal was to copyright the text – so as to protect my authorship – but expressly allow anyone to distribute and/or modify the text to suit their own needs with a minimum of legal encumbrance. This willful and formal revoking of standard distribution limitations under copyright is whimsically termed *copyleft*. Anyone can “copyleft” their creative work simply by appending a notice to that effect on their work, but several Licenses already exist, covering the fine legal points in great detail.

The first such License I applied to my work was the GPL – General Public License – of the Free Software Foundation (GNU). The GPL, however, is intended to copyleft works of computer software, and although its introductory language is broad enough to cover works of text, its wording is not as clear as it could be for that application. When other, less specific copyleft Licenses began appearing within the free software community, I chose one of them (the Design Science License, or DSL) as the official notice for my project.

In “copylefting” this text, I guaranteed that no instructor would be limited by a text insufficient for their needs, as I had been with error-ridden textbooks from major publishers. I’m sure this book in its initial form will not satisfy everyone, but anyone has the freedom to change it, leveraging my efforts to suit variant and individual requirements. For the beginning student of electronics, learn what you can from this book, editing it as you feel necessary if you come across a useful piece of information. Then, if you pass it on to someone else, you will be giving them something better than what you received. For the instructor or electronics professional, feel free to use this as a reference manual, adding or editing to your heart’s content. The only “catch” is this: if you plan to distribute your modified version of this text, you must give credit where credit is due (to me, the original author, and anyone else whose modifications are contained in your version), and you must ensure that whoever you give the text to is aware of their freedom to similarly share and edit the text. The next chapter covers this process in more detail.

It must be mentioned that although I strive to maintain technical accuracy in all of this book’s content, the subject matter is broad and harbors many potential dangers. Electricity maims and kills without provocation, and deserves the utmost respect. I strongly encourage experimentation on the part of the reader, but only with circuits powered by small batteries where there is no risk of electric shock, fire, explosion, etc. High-power electric circuits should be left to the care of trained professionals! The Design Science License clearly states that neither I nor any contributors to this book bear any liability for what is done with its contents.

A-1.2 The use of SPICE

One of the best ways to learn how things work is to follow the inductive approach: to observe specific instances of things working and derive general conclusions from those observations. In science education, labwork is the traditionally accepted venue for this type of learning, although in many cases labs are designed by educators to reinforce principles previously learned through lecture or textbook reading, rather than to allow the student to learn on their own through a truly exploratory process.

Having taught myself most of the electronics that I know, I appreciate the sense of frustration students may have in teaching themselves from books. Although electronic components are typically inexpensive, not everyone has the means or opportunity to set up a laboratory in their own homes, and when things go wrong there’s no one to ask for help. Most textbooks

seem to approach the task of education from a deductive perspective: tell the student how things are supposed to work, then apply those principles to specific instances that the student may or may not be able to explore by themselves. The inductive approach, as useful as it is, is hard to find in the pages of a book.

However, textbooks don't have to be this way. I discovered this when I started to learn a computer program called SPICE. It is a text-based piece of software intended to model circuits and provide analyses of voltage, current, frequency, etc. Although nothing is quite as good as building real circuits to gain knowledge in electronics, computer simulation is an excellent alternative. In learning how to use this powerful tool, I made a discovery: SPICE could be used within a textbook to present circuit simulations to allow students to "observe" the phenomena for themselves. This way, the readers could learn the concepts inductively (by interpreting SPICE's output) as well as deductively (by interpreting my explanations). Furthermore, in seeing SPICE used over and over again, they should be able to understand how to use it themselves, providing a perfectly safe means of experimentation on their own computers with circuit simulations of their own design.

Another advantage to including computer analyses in a textbook is the empirical verification it adds to the concepts presented. Without demonstrations, the reader is left to take the author's statements on faith, trusting that what has been written is indeed accurate. The problem with faith, of course, is that it is only as good as the authority in which it is placed and the accuracy of interpretation through which it is understood. Authors, like all human beings, are liable to err and/or communicate poorly. With demonstrations, however, the reader can immediately see for themselves that what the author describes is indeed true. Demonstrations also serve to clarify the meaning of the text with concrete examples.

SPICE is introduced early in volume I (DC) of this book series, and hopefully in a gentle enough way that it doesn't create confusion. For those wishing to learn more, a chapter in this volume (volume V) contains an overview of SPICE with many example circuits. There may be more flashy (graphic) circuit simulation programs in existence, but SPICE is free, a virtue complementing the charitable philosophy of this book very nicely.

A-1.3 Acknowledgements

First, I wish to thank my wife, whose patience during those many and long evenings (and weekends!) of typing has been extraordinary.

I also wish to thank those whose open-source software development efforts have made this endeavor all the more affordable and pleasurable. The following is a list of various free computer software used to make this book, and the respective programmers:

- *GNU/Linux* Operating System – Linus Torvalds, Richard Stallman, and a host of others too numerous to mention.
- *Vim* text editor – Bram Moolenaar and others.
- *Xcircuit* drafting program – Tim Edwards.
- *SPICE* circuit simulation program – too many contributors to mention.
- *T_EX* text processing system – Donald Knuth and others.

- *Texinfo* document formatting system – Free Software Foundation.
- \LaTeX document formatting system – Leslie Lamport and others.
- *Gimp* image manipulation program – too many contributors to mention.
- *Winscope* signal analysis software – Dr. Constantin Zeldovich. (Free for personal and academic use.)

Appreciation is also extended to Robert L. Boylestad, whose first edition of *Introductory Circuit Analysis* taught me more about electric circuits than any other book. Other important texts in my electronics studies include the 1939 edition of *The "Radio" Handbook*, Bernard Grob's second edition of *Introduction to Electronics I*, and Forrest Mims' original *Engineer's Notebook*.

Thanks to the staff of the Bellingham Antique Radio Museum, who were generous enough to let me terrorize their establishment with my camera and flash unit.

I wish to specifically thank Jeffrey Elkner and all those at Yorktown High School for being willing to host my book as part of their Open Book Project, and to make the first effort in contributing to its form and content. Thanks also to David Sweet (website: (<http://www.andamooka.org>)) and Ben Crowell (website: (<http://www.lightandmatter.com>)) for providing encouragement, constructive criticism, and a wider audience for the online version of this book.

Thanks to Michael Stutz for drafting his Design Science License, and to Richard Stallman for pioneering the concept of copyleft.

Last but certainly not least, many thanks to my parents and those teachers of mine who saw in me a desire to learn about electricity, and who kindled that flame into a passion for discovery and intellectual adventure. I honor you by helping others as you have helped me.

Tony Kuphaldt, July 2001

"A candle loses nothing of its light when lighting another"
Kahlil Gibran

Appendix A-2

CONTRIBUTOR LIST

A-2.1 How to contribute to this book

As a copylefted work, this book is open to revision and expansion by any interested parties. The only "catch" is that credit must be given where credit is due. This *is* a copyrighted work: it is *not* in the public domain!

If you wish to cite portions of this book in a work of your own, you must follow the same guidelines as for any other copyrighted work. Here is a sample from the Design Science License:

The Work is copyright the Author. All rights to the Work are reserved by the Author, except as specifically described below. This License describes the terms and conditions under which the Author permits you to copy, distribute and modify copies of the Work.

In addition, you may refer to the Work, talk about it, and (as dictated by "fair use") quote from it, just as you would any copyrighted material under copyright law.

Your right to operate, perform, read or otherwise interpret and/or execute the Work is unrestricted; however, you do so at your own risk, because the Work comes WITHOUT ANY WARRANTY -- see Section 7 ("NO WARRANTY") below.

If you wish to modify this book in any way, you must document the nature of those modifications in the "Credits" section along with your name, and ideally, information concerning how you may be contacted. Again, the Design Science License:

Permission is granted to modify or sample from a copy of the Work,

producing a derivative work, and to distribute the derivative work under the terms described in the section for distribution above, provided that the following terms are met:

- (a) The new, derivative work is published under the terms of this License.
- (b) The derivative work is given a new name, so that its name or title can not be confused with the Work, or with a version of the Work, in any way.
- (c) Appropriate authorship credit is given: for the differences between the Work and the new derivative work, authorship is attributed to you, while the material sampled or used from the Work remains attributed to the original Author; appropriate notice must be included with the new work indicating the nature and the dates of any modifications of the Work made by you.

Given the complexities and security issues surrounding the maintenance of files comprising this book, it is recommended that you submit any revisions or expansions to the original author (Tony R. Kuphaldt). You are, of course, welcome to modify this book directly by editing your own personal copy, but we would all stand to benefit from your contributions if your ideas were incorporated into the online “master copy” where all the world can see it.

A-2.2 Credits

All entries arranged in alphabetical order of surname. Major contributions are listed by individual name with some detail on the nature of the contribution(s), date, contact info, etc. Minor contributions (typo corrections, etc.) are listed by name only for reasons of brevity. Please understand that when I classify a contribution as “minor,” it is in no way inferior to the effort or value of a “major” contribution, just smaller in the sense of less text changed. Any and all contributions are gratefully accepted. I am indebted to all those who have given freely of their own knowledge, time, and resources to make this a better book!

A-2.2.1 Dennis Crunkilton

- **Date(s) of contribution(s):** January 2006 to present
- **Nature of contribution:** Mini table of contents, all chapters except appedicies; html, latex, ps, pdf; See Devel/tutorial.html; 01/2006.
- **Nature of contribution:** CH 4, section: AC induction motor, 09/2007.
- **Contact at:** dcrunkilton(at)att(dot)net

A-2.2.2 Tony R. Kuphaldt

- **Date(s) of contribution(s):** 1996 to present
- **Nature of contribution:** Original author.
- **Contact at:** liec0@lycos.com

A-2.2.3 Bill Marsden

- **Date(s) of contribution(s):** August 2008
- **Nature of contribution:** Original author: “555 Schmidt trigger” Section, Chapter 7.
- **Contact at:** bill_marsden2(at)hotmail(dot)com

A-2.2.4 Forrest M. Mims III

- **Date(s) of contribution(s):** February 2008
- **Nature of contribution:** Ch 5; Clarification concerning LEDs as photosensors.
- **Contact at:** FMims(at)aol.com

A-2.2.5 Your name here

- **Date(s) of contribution(s):** Month and year of contribution
- **Nature of contribution:** Insert text here, describing how you contributed to the book.
- **Contact at:** my_email@provider.net

A-2.2.6 Typo corrections and other “minor” contributions

- **line-allaboutcircuits.com** (June 2005) Typographical error correction in Volumes 1,2,3,5, various chapters ,(s/visa-versa/vice versa/).
- *The students of Bellingham Technical College’s Instrumentation program.*
- **Colin Creitz** (May 2007) Chapters: several, s/it’s/its.
- **Jeff DeFreitas** (March 2006) Improve appearance: replace “/” and ”/” Chapters: A1, A2.
- **Don Stalkowski** (June 2002) Technical help with PostScript-to-PDF file format conversion.
- **Joseph Teichman** (June 2002) Suggestion and technical help regarding use of PNG images instead of JPEG.
- **Michael Warner** (April 2002) Suggestions for a section describing home laboratory setup.

- **jut@allaboutcircuits.com** (August 2007) Ch 1, s/starting/started .
- **Unregistered@allaboutcircuits.com** (August 2007) Ch 6, s/and and off/on and off/ .
- **Timothy Unregistered@allaboutcircuits.com** (Feb 2008) Changed default roman font to newcent.
- **Imranullah Syed** (Feb 2008) Suggested centering of uncaptioned schematics.
- **Sylverce@allaboutcircuits.com, Caveman@allaboutcircuits.com** (May 2008) Changed image 05320.png to agree with inage 05321.png;item
- **sarwiz@allaboutcircuits.com** (April 2009) s/Try changed/Try changing;/i/item $\dot{}$

Appendix A-3

DESIGN SCIENCE LICENSE

Copyright © 1999-2000 Michael Stutz stutz@dsl.org
Verbatim copying of this document is permitted, in any medium.

A-3.1 0. Preamble

Copyright law gives certain exclusive rights to the author of a work, including the rights to copy, modify and distribute the work (the "reproductive," "adaptative," and "distribution" rights).

The idea of "copyleft" is to willfully revoke the exclusivity of those rights under certain terms and conditions, so that anyone can copy and distribute the work or properly attributed derivative works, while all copies remain under the same terms and conditions as the original.

The intent of this license is to be a general "copyleft" that can be applied to any kind of work that has protection under copyright. This license states those certain conditions under which a work published under its terms may be copied, distributed, and modified.

Whereas "design science" is a strategy for the development of artifacts as a way to reform the environment (not people) and subsequently improve the universal standard of living, this Design Science License was written and deployed as a strategy for promoting the progress of science and art through reform of the environment.

A-3.2 1. Definitions

"License" shall mean this Design Science License. The License applies to any work which contains a notice placed by the work's copyright holder stating that it is published under the terms of this Design Science License.

"Work" shall mean such an aforementioned work. The License also applies to the output of the Work, only if said output constitutes a "derivative work" of the licensed Work as defined by copyright law.

”Object Form” shall mean an executable or performable form of the Work, being an embodiment of the Work in some tangible medium.

”Source Data” shall mean the origin of the Object Form, being the entire, machine-readable, preferred form of the Work for copying and for human modification (usually the language, encoding or format in which composed or recorded by the Author); plus any accompanying files, scripts or other data necessary for installation, configuration or compilation of the Work.

(Examples of ”Source Data” include, but are not limited to, the following: if the Work is an image file composed and edited in ’PNG’ format, then the original PNG source file is the Source Data; if the Work is an MPEG 1.0 layer 3 digital audio recording made from a ’WAV’ format audio file recording of an analog source, then the original WAV file is the Source Data; if the Work was composed as an unformatted plaintext file, then that file is the the Source Data; if the Work was composed in LaTeX, the LaTeX file(s) and any image files and/or custom macros necessary for compilation constitute the Source Data.)

”Author” shall mean the copyright holder(s) of the Work.

The individual licensees are referred to as ”you.”

A-3.3 2. Rights and copyright

The Work is copyright the Author. All rights to the Work are reserved by the Author, except as specifically described below. This License describes the terms and conditions under which the Author permits you to copy, distribute and modify copies of the Work.

In addition, you may refer to the Work, talk about it, and (as dictated by ”fair use”) quote from it, just as you would any copyrighted material under copyright law.

Your right to operate, perform, read or otherwise interpret and/or execute the Work is unrestricted; however, you do so at your own risk, because the Work comes WITHOUT ANY WARRANTY – see Section 7 (”NO WARRANTY”) below.

A-3.4 3. Copying and distribution

Permission is granted to distribute, publish or otherwise present verbatim copies of the entire Source Data of the Work, in any medium, provided that full copyright notice and disclaimer of warranty, where applicable, is conspicuously published on all copies, and a copy of this License is distributed along with the Work.

Permission is granted to distribute, publish or otherwise present copies of the Object Form of the Work, in any medium, under the terms for distribution of Source Data above and also provided that one of the following additional conditions are met:

(a) The Source Data is included in the same distribution, distributed under the terms of this License; or

(b) A written offer is included with the distribution, valid for at least three years or for as long as the distribution is in print (whichever is longer), with a publicly-accessible address (such as a URL on the Internet) where, for a charge not greater than transportation and media costs, anyone may receive a copy of the Source Data of the Work distributed according to the section above; or

(c) A third party's written offer for obtaining the Source Data at no cost, as described in paragraph (b) above, is included with the distribution. This option is valid only if you are a non-commercial party, and only if you received the Object Form of the Work along with such an offer.

You may copy and distribute the Work either gratis or for a fee, and if desired, you may offer warranty protection for the Work.

The aggregation of the Work with other works which are not based on the Work – such as but not limited to inclusion in a publication, broadcast, compilation, or other media – does not bring the other works in the scope of the License; nor does such aggregation void the terms of the License for the Work.

A-3.5 4. Modification

Permission is granted to modify or sample from a copy of the Work, producing a derivative work, and to distribute the derivative work under the terms described in the section for distribution above, provided that the following terms are met:

(a) The new, derivative work is published under the terms of this License.

(b) The derivative work is given a new name, so that its name or title can not be confused with the Work, or with a version of the Work, in any way.

(c) Appropriate authorship credit is given: for the differences between the Work and the new derivative work, authorship is attributed to you, while the material sampled or used from the Work remains attributed to the original Author; appropriate notice must be included with the new work indicating the nature and the dates of any modifications of the Work made by you.

A-3.6 5. No restrictions

You may not impose any further restrictions on the Work or any of its derivative works beyond those restrictions described in this License.

A-3.7 6. Acceptance

Copying, distributing or modifying the Work (including but not limited to sampling from the Work in a new work) indicates acceptance of these terms. If you do not follow the terms of this License, any rights granted to you by the License are null and void. The copying, distribution or modification of the Work outside of the terms described in this License is expressly prohibited by law.

If for any reason, conditions are imposed on you that forbid you to fulfill the conditions of this License, you may not copy, distribute or modify the Work at all.

If any part of this License is found to be in conflict with the law, that part shall be interpreted in its broadest meaning consistent with the law, and no other parts of the License shall be affected.

A-3.8 7. No warranty

THE WORK IS PROVIDED "AS IS," AND COMES WITH ABSOLUTELY NO WARRANTY, EXPRESS OR IMPLIED, TO THE EXTENT PERMITTED BY APPLICABLE LAW, INCLUDING BUT NOT LIMITED TO THE IMPLIED WARRANTIES OF MERCHANTABILITY OR FITNESS FOR A PARTICULAR PURPOSE.

A-3.9 8. Disclaimer of liability

IN NO EVENT SHALL THE AUTHOR OR CONTRIBUTORS BE LIABLE FOR ANY DIRECT, INDIRECT, INCIDENTAL, SPECIAL, EXEMPLARY, OR CONSEQUENTIAL DAMAGES (INCLUDING, BUT NOT LIMITED TO, PROCUREMENT OF SUBSTITUTE GOODS OR SERVICES; LOSS OF USE, DATA, OR PROFITS; OR BUSINESS INTERRUPTION) HOWEVER CAUSED AND ON ANY THEORY OF LIABILITY, WHETHER IN CONTRACT, STRICT LIABILITY, OR TORT (INCLUDING NEGLIGENCE OR OTHERWISE) ARISING IN ANY WAY OUT OF THE USE OF THIS WORK, EVEN IF ADVISED OF THE POSSIBILITY OF SUCH DAMAGE.

END OF TERMS AND CONDITIONS

[\$Id: dsl.txt,v 1.25 2000/03/14 13:14:14 m Exp m \$]

Index

- β ratio, 255
- 555 timer, 310, 313, 316

- AC, 145
- AC coupling, oscilloscope, 193, 208
- Active-high input, 364
- Active-low input, 364
- Alligator clip, 19
- Alternating current, 145
- Alternator, 164
- Amp, 36
- Ampere, 36
- Amplifier circuit, 134
- Amplifier impedance, 242
- Amplifier, inverting, 245, 297
- Amplifier, noninverting, 297
- Amplifier, operational, 250
- Amplitude, 182
- Analog, 287, 329
- Analog computer, 133, 144
- Analog multimeter, 16
- Antiresonance, 189
- Astable multivibrator, 273, 310
- Audio taper potentiometer, 87, 117, 155
- Autoranging meter, 18

- Banana plugs and jacks, 99
- Battery, 19
- Beta ratio, 255
- Bias current, op-amp, 307
- Binding posts, 99
- Bounce, switch contact, 343, 354
- Breadboard, 22

- Calculus, 143, 304
- Calibration drift—hyperpage, 107
- Capacitor, decoupling, 196

- Choke, 188
- Choke, filter, 223
- Circuit, 29
- Circuit, short, 32
- Common-mode voltage, 265
- Commonality, electrical, 24
- Computer simulation, 76
- Computer, analog, 133, 144
- Constant-current diode, 261
- Contact bounce, 343, 354
- Continuity, 22
- Continuity vs. commonality, 24
- Current divider, 84
- Current mirror, 261, 313
- Current regulator, 255
- Current, definition, 36

- DC, 59
- Debouncing, switch, 355
- Decoupling capacitor, 196
- Derivative, calculus, 143, 304
- Detector, null, 124
- Differential amplifier, 265, 268
- Differential pair, 265, 268
- Differentiation, calculus, 143, 304
- Digital, 287, 329
- Digital multimeter, 16
- Diode, 26
- Diode equation, 256
- Diode, constant-current, 261
- Direct current, 59
- Discontinuity, 29
- Divider, current, 84
- Divider, voltage, 70
- Drift, calibration, 107
- Duty cycle, 310

- E, symbol for voltage, 44
- Effect, Seebeck, 110
- Electrical continuity, 22
- Electrical shock hazard, 26
- Electrically common points, 24, 64
- Electromagnetic induction, 57
- Electromagnetism, 56
- Equation, diode, 256
- Experiment: 3-bit binary counter, 360
- Experiment: 4-wire resistance measurement, 127
- Experiment: 555 audio oscillator, 309
- Experiment: 555 ramp generator, 312
- Experiment: 555 Schmitt Trigger, 345
- Experiment: 7-segment display, 362
- Experiment: AC power supply, 147
- Experiment: Alternator, 164
- Experiment: Ammeter usage, 35
- Experiment: Audio detector, 155
- Experiment: Audio oscillator, 272
- Experiment: Basic gate function, 331
- Experiment: BJT switch, 228
- Experiment: Bridge rectifier, 216
- Experiment: Capacitor charging and discharging, 138
- Experiment: Center-tap rectifier, 211
- Experiment: Class B audio amplifier, 319
- Experiment: Common-emitter amplifier, 244
- Experiment: Commutating diode, 201
- Experiment: Current divider, 78
- Experiment: Current mirror, 253
- Experiment: Differential amplifier, 264
- Experiment: Electromagnetic field sensor, AC, 160
- Experiment: Electromagnetic induction, 57
- Experiment: Electromagnetism, 55
- Experiment: Electrostatic field sensor, AC, 162
- Experiment: Half-wave rectifier, 203
- Experiment: High-impedance voltmeter, 299
- Experiment: Induction motor, 170
- Experiment: Integrator, 303
- Experiment: JFET current regulator, 259
- Experiment: Keyboard as signal generator, 180
- Experiment: LED sequencer, 348
- Experiment: Multi-stage amplifier, 249
- Experiment: Multimeter, 112
- Experiment: NAND gate S-R enabled latch, 339
- Experiment: NAND gate S-R flip-flop, 341
- Experiment: Noninverting amplifier, 296
- Experiment: Nonlinear resistance, 45
- Experiment: NOR gate S-R latch, 335
- Experiment: Ohm's Law, 42
- Experiment: Ohmmeter usage, 21
- Experiment: Oscilloscope, PC, 183
- Experiment: Parallel batteries, 63
- Experiment: Phase shift, 174
- Experiment: Potato battery, 136
- Experiment: Potentiometer as rheostat, 93
- Experiment: Potentiometer as voltage divider, 87
- Experiment: Potentiometric voltmeter, 122
- Experiment: Power dissipation, 48
- Experiment: Precision potentiometer, 99
- Experiment: Precision voltage follower, 292
- Experiment: Pulsed-light sensor, 236
- Experiment: PWM power controller, 315
- Experiment: Rate-of-change indicator, 142
- Experiment: Rectifier/filter, 219
- Experiment: Rheostat range limiting, 102
- Experiment: Series batteries, 60
- Experiment: Signal coupling, 191
- Experiment: Simple circuit, 28
- Experiment: Simple combination lock, 357
- Experiment: Simple op-amp, 267
- Experiment: Sound cancellation, 177
- Experiment: Static electricity sensor, 233
- Experiment: Switch in circuit, 53
- Experiment: Tank circuit, 188
- Experiment: Thermoelectricity, 109
- Experiment: Transformer, homemade, 151
- Experiment: Vacuum tube audio amplifier, 275
- Experiment: Variable inductor, 153
- Experiment: Voltage averager, 131
- Experiment: Voltage comparator, 289
- Experiment: Voltage detector, sensitive, 117
- Experiment: Voltage divider, 67
- Experiment: Voltage follower, 239
- Experiment: Voltage regulator, 225
- Experiment: Voltmeter usage, 15
- Experiment: Waveform analysis, 186

- Feedback, 288, 293
- Feedback, negative, 246
- Field winding, alternator, 164
- Filter, 221
- Filter choke, 223
- Floating input, defined, 333, 354
- Frequency, 182
- Frequency domain, 187
- Full-wave rectification, 212
- Function generator, 181
- Fundamental frequency, 187
- Fuse, 37
- Fuse, slow-blow, 147

- Generator, 19, 164
- Generator, AC signal, 181

- Half-wave rectification, 204
- Harmonics, 182
- Hazard, electrical shock, 26
- Headphone, 117
- Heat sink, 221
- Hysteresis, 336

- I, symbol for current, 44
- IC, 200, 287, 329
- Illegal state, 336
- Impedance matching, 120, 158
- Impedance, amplifier, 242
- Impedance, definition, 120, 158
- Induction, electromagnetic, 57
- Inductive kickback—hyperpage, 56, 120, 158
- Integrated circuit, 200, 287, 329
- Integration, calculus, 304
- Interactive adjustment, 101
- Invalid state, 336
- Inverting amplifier, 245, 297

- Joule's Law, 51
- Jumper wire, 19

- KCL, 84
- Kirchhoff's Current Law, 84
- Kirchhoff's Voltage Law, 70
- KVL, 70

- Latch-up, 302

- Latched state, 336
- LED, 18
- Light-Emitting Diode, 18
- Linear taper potentiometer, 87, 117, 155

- Magnet wire, 55, 151
- Maximum Power Transfer Theorem, 120, 158
- Megger, 128
- Meter movement, 112
- Meter overrange, 18
- Metric prefix, 25, 38
- Monostable multivibrator, 355
- Motor, induction, 168
- Motor, synchronous, 168
- Movement, meter, 112
- Multimeter, 16
- Multivibrator, 273, 310
- Multivibrator, monostable, 355

- Negative feedback, 246
- Noninverting amplifier, 297
- Null detector, 124
- Null-balance voltmeter, 124

- Ohm, 22
- Ohm's Law, 44
- Ohm's Law, AC version, 175
- Op-amp, 265, 268
- Operational amplifier, 250, 265, 268, 288
- Operational amplifier, programmable, 271
- Oscilloscope, 184
- Oscilloscope coupling, 193, 208
- Overrange, meter, 18

- Pair, differential, 265, 268
- Parallel, 64, 105
- Permeability, 154
- Phase shift, 175
- Photocell, 27
- Polarity, 19, 31
- Potentiometer, 87
- Potentiometer as rheostat, 94
- Potentiometer, linear vs. audio taper, 87
- Potentiometric voltmeter, 124
- Power supply, 145
- Power, definition, 51

- Programmable op-amp, [271](#)
- Pulldown resistor, [353](#)
- Pulse-width modulation, [317](#)
- PWM power control, [317](#)

- Q, inductor quality factor—hyperpage, [189](#)

- R, symbol for resistance, [44](#)
- Race condition, [337](#)
- Rail voltage, [294](#)
- Rectification, full-wave, [212](#)
- Rectification, half-wave, [204](#)
- Rectifying diode, [26](#)
- Regulator, current, [255](#)
- Reluctance, magnetic, [152](#)
- Reset state, [336](#)
- Resistance, definition, [22](#)
- Resistor color code, [24](#)
- Resistor, pulldown, [353](#)
- Resistor, shunt, [241](#)
- Resonance, [189](#)
- Resonant frequency, [189](#)
- Rheostat, [94](#)
- Ring-lug terminal, [165](#)
- Ripple voltage, [206](#), [221](#)

- Schmitt trigger, [345](#)
- Seebeck effect, [110](#)
- Semiconductor, [200](#)
- Series, [61](#), [104](#)
- Series-parallel, [66](#)
- Set state, [336](#)
- Shielding, [161](#), [163](#)
- Shock hazard, [26](#)
- Short circuit, [32](#)
- Shunt resistor, [241](#)
- Signal generator, [181](#)
- Simulation, computer, [76](#)
- Slip ring, alternator, [165](#)
- Soldering, [148](#)
- Span calibration, [105](#)
- SPICE, [76](#)
- Split phase, [217](#)
- Stator winding, alternator, [164](#)
- Strip, terminal, [34](#)
- Switch, [53](#)

- Switch debouncing, [355](#)

- Tank circuit, [189](#)
- Terminal strip, [34](#)
- Terminal, ring lug, [165](#)
- Thermal runaway, [257](#), [261](#)
- Thermocouple, [110](#)
- Time constant, [140](#)
- Time domain, [187](#)
- Transformer, [117](#), [145](#)
- Transistor, [96](#)
- Transistor, junction field-effect, [234](#)

- Unit, ampere, [36](#)
- Unit, ohm, [22](#)
- Unit, volt, [18](#)
- Unit, watt, [51](#)

- Volt, [18](#)
- Voltage divider, [70](#)
- Voltage follower, [240](#), [268](#), [293](#)
- Voltage, common-mode, [265](#)
- Voltage, definition, [18](#)
- Voltage, polarity, [19](#), [31](#)
- Voltage, ripple, [206](#), [221](#)

- Watt, [51](#)
- Wire, magnet, [55](#)

- Z, symbol for impedance, [120](#), [158](#)
- Zero calibration, [105](#)

.