

Fisher™ i2P-100 Electro-Pneumatic Transducer

Contents

Introduction	1
Scope of Manual	1
Description	2
Specifications	2
Educational Services	2
Installation	5
Hazardous Area Classifications and Special Instructions for “Safe Use” and Installation in Hazardous Locations	7
Mounting	7
Pneumatic Connections	8
Supply Pressure Requirements	9
Diagnostic Connections	10
Vent	10
Electrical Connections	11
Operating Information	12
Calibration	12
Equipment Required	12
Calibration Procedure	12
Principle of Operation	14
Maintenance	14
Troubleshooting	16
Converter Module Replacement	16
Electronics Module Replacement	17
Relay Maintenance	18

Figure 1. Fisher i2P-100 Electro-Pneumatic Transducer

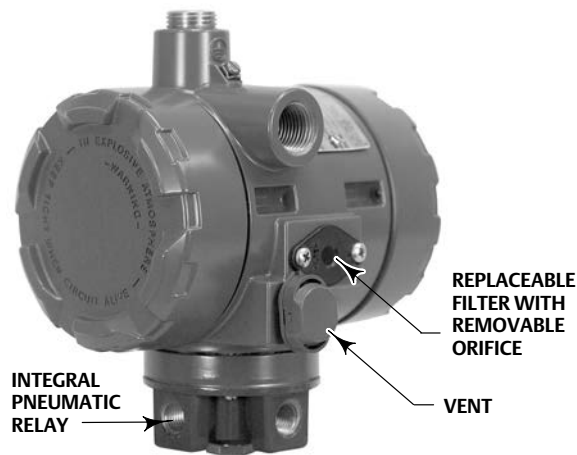

W8710

Parts Ordering	19
Parts List	20

Introduction

Scope of Manual

This instruction manual provides installation, operation, maintenance, and parts ordering information for the Fisher i2P-100 transducer (see figure 1).

Refer to separate manuals for instructions covering equipment used with the transducer.



Do not install, operate, or maintain an i2P-100 electro-pneumatic transducer without being fully trained and qualified in valve, actuator, and accessory installation, operation and maintenance. To avoid personal injury or property damage it is important to carefully read, understand, and follow all of the contents of this manual, including all safety cautions and warnings. If you have any questions about these instructions, contact your [Emerson sales office](#).

NOTICE

Dropping or rough handling of the transducer can cause damage to the converter module resulting in a shifted output or a minimum output.

Description

The transducer receives a 4-20 mA DC input signal and transmits a proportional user field-configurable pneumatic output pressure to a final control element. The pneumatic output ranges are typically 0.2 to 1.0 bar (3 to 15 psig), 0.4 to 2.0 bar (6 to 30 psig), and 0.14 to 2.3 bar (2 to 33 psi). A typical application is in electronic control loops where the final control element is a control valve assembly that is pneumatically operated. The input signal and output pressure range of the transducer is indicated on the nameplate, attached to the housing.

Specifications

Specifications for the i2P-100 transducer are listed in table 1.

⚠ WARNING

This product is intended for a specific current range, temperature range and other application specifications. Applying different current, temperature and other service conditions could result in malfunction of the product, property damage or personal injury.

Educational Services

Emerson Automation Solutions
Educational Services - Registration
Phone: +1-800-338-8158
E-mail: education@emerson.com
emerson.com/my training

Go to:
www.fisher.com/energyresponsibletool/
to calculate pneumatic energy savings

Scan or click
code to find out
more about the
i2P-100 transducer



Table 1. Specifications

<p>Input Signal Available as standard with 4-20 mA. User configurable by dip switch for split ranging, see table below.</p> <p>Output Signal⁽¹⁾ Available as standard 0.2 to 1.0 bar (3 to 15 psig), 0.4 to 2.0 bar (6 to 30 psig), or 0.14 to 2.3 bar (2 to 33 psig). User configurable by dip switch selection and zero and span potentiometer adjustment, see table below.</p> <table border="1"> <thead> <tr> <th rowspan="2">Input Signal</th> <th colspan="2">Output Pressure</th> </tr> <tr> <th>Bar</th> <th>psig</th> </tr> </thead> <tbody> <tr> <td rowspan="3">4-20 mA DC</td> <td>0.2 to 1.0</td> <td>3 to 15</td> </tr> <tr> <td>0.4 to 2.0</td> <td>6 to 30</td> </tr> <tr> <td>0.14 to 2.3</td> <td>2 to 33</td> </tr> <tr> <td>4-12 mA DC</td> <td>0.2 to 1.0</td> <td>3 to 15</td> </tr> <tr> <td>12-20 mA DC</td> <td>0.2 to 1.0</td> <td>3 to 15</td> </tr> </tbody> </table> <p>Equivalent Circuit The i2P-100 equivalent circuit is a series circuit consisting of a constant voltage drop (battery) of approximately 4 VDC and a total resistance of 40 ohms. Input is shunted by two 6.8 V zener diodes (see figure 9).</p> <p>Supply Pressure⁽²⁾ Recommended: 0.3 bar (5 psi) higher than upper range limit of output signal Maximum: 3.4 bar (50 psig)</p> <p>Medium: Air or Non-Corrosive Natural Gas</p> <p>Maximum Steady-State Flow Rate Refer to tables 3 and 4</p> <p>Maximum Output Air Capacity⁽³⁾ 8.0 m³/hr (300 scfh) at 1.4 bar (20 psig) supply pressure</p> <p>Performance⁽⁴⁾ Reference Accuracy: ±1.0% of full scale output span; includes combined effects of hysteresis, linearity, and deadband</p>	Input Signal	Output Pressure		Bar	psig	4-20 mA DC	0.2 to 1.0	3 to 15	0.4 to 2.0	6 to 30	0.14 to 2.3	2 to 33	4-12 mA DC	0.2 to 1.0	3 to 15	12-20 mA DC	0.2 to 1.0	3 to 15	<p>Independent Linearity: ±0.5% of full scale output span</p> <p>Hysteresis: 0.4% of full scale output span</p> <p>Frequency Response: Gain is attenuated 3 dB at 3 Hz with transducer output signal piped to a typical instrument input</p> <p>Temperature Effect: ±0.14% per degrees Celsius (±0.075% per degrees Fahrenheit) of span</p> <p>Supply Pressure Effect: 0.2% of full scale output span per psi supply pressure change</p> <p>Vibration Effect: Less than 1% of full scale output span when tested to ISA S75.13</p> <p>Electromagnetic Compatibility Meets EN 61326-1:2013 Immunity—Industrial locations per Table 2 of EN 61326-1 Standard. Performance is shown in table 2 below. Emissions—Class A ISM equipment rating: Group 1, Class A</p> <p>Operating Ambient Temperature Limits⁽²⁾ -40 to 85°C (-40 to 185°F)</p> <p>Electrical Seal Single sealed device per ANSI/ISA 12.27.01</p> <p>Electrical Classification Hazardous Area: CSA—Intrinsically Safe, Explosion-proof, Type n, Dust-Ignition proof FM—Intrinsically Safe, Explosion-proof, Type n, Non-incendive, Dust-Ignition proof ATEX—Intrinsically Safe, Flameproof, Type n IECEx—Intrinsically Safe, Flameproof, Type n</p> <p>Electrical Housing:</p> <table border="0"> <tr> <td>When Remotely Vented</td> <td>No Remote Venting</td> </tr> <tr> <td>CSA—Type 4X Encl.</td> <td>CSA—Type 3 Encl.</td> </tr> <tr> <td>FM—NEMA 4X</td> <td>FM—NEMA 3</td> </tr> <tr> <td>ATEX—IP66</td> <td>ATEX—IP64</td> </tr> <tr> <td>IECEx—IP66</td> <td>IECEx—IP64</td> </tr> </table>	When Remotely Vented	No Remote Venting	CSA—Type 4X Encl.	CSA—Type 3 Encl.	FM—NEMA 4X	FM—NEMA 3	ATEX—IP66	ATEX—IP64	IECEx—IP66	IECEx—IP64
Input Signal		Output Pressure																											
	Bar	psig																											
4-20 mA DC	0.2 to 1.0	3 to 15																											
	0.4 to 2.0	6 to 30																											
	0.14 to 2.3	2 to 33																											
4-12 mA DC	0.2 to 1.0	3 to 15																											
12-20 mA DC	0.2 to 1.0	3 to 15																											
When Remotely Vented	No Remote Venting																												
CSA—Type 4X Encl.	CSA—Type 3 Encl.																												
FM—NEMA 4X	FM—NEMA 3																												
ATEX—IP66	ATEX—IP64																												
IECEx—IP66	IECEx—IP64																												

(continued)

Table 1. Specifications (continued)

<p>Other Classifications/Certifications</p> <p>CUTR— Customs Union Technical Regulations (Russia, Kazakhstan, Belarus, and Armenia)</p> <p>INMETRO— National Institute of Metrology, Quality, and Technology (Brazil)</p> <p>KTL—Korea Testing Laboratory (South Korea)</p> <p>NEPSI— National Supervision and Inspection Centre for Explosion Protection and Safety of Instrumentation (China)</p> <p>Contact your Emerson sales office for classification/certification specific information</p> <p>Connections</p> <p>Supply and Output Pressure: 1/4 NPT internal connection</p> <p>Vent: 1/4 NPT internal</p> <p>Electrical: Standard 1/2 NPT</p> <p>Wire Size: 18 to 22 AWG</p> <p>Adjustments⁽¹⁾</p> <p>Zero and Span: Trim potentiometers (20 turn) for zero and span adjustments are located under the housing cap (see figure 10).</p> <p>Switch: Allows input signal split range and user-configurable 0.14 to 2.3 bar (2 to 33 psig) output.</p>	<p>Mounting Position</p> <p>■ Actuator ■ pipestand or ■ surface</p> <p>Approximate Weight (Transducer Only)</p> <p>2.5 kg (5.5 lbs)</p> <p>Actuator Stroking Time</p> <p>See figure 2</p> <p>Declaration of SEP</p> <p>Fisher Controls International LLC declares this product to be in compliance with Article 4 paragraph 3 of the PED Directive 2014/68/EU. It was designed and manufactured in accordance with Sound Engineering Practice (SEP) and cannot bear the CE marking related to PED compliance.</p> <p>However, the product <i>may</i> bear the CE marking to indicate compliance with <i>other</i> applicable European Community Directives.</p>
--	---

NOTE: Specialized instrument terms are defined in ANSI/ISA Standard 51.1 - Process Instrument Terminology

1. For other ranges, zero and span adjustments are needed.

2. The pressure and temperature limits in this document and any applicable standard or code limitation should not be exceeded.

3. Normal m³/hr—Normal cubic meters per hour (0°C and 1.01325 bar, absolute). Scfh—Standard cubic feet per hour (60°F and 14.7 psia).

4. Performance values are obtained using a transducer with a 4 to 20 mA DC input signal and a 0.2 to 1.0 bar (3 to 15 psig) output signal at an ambient temperature of 24°C (75°F).

Table 2. EMC Summary Results—Immunity

Port	Phenomenon	Basic Standard	Test Level	Performance Criteria ⁽¹⁾
Enclosure	Electrostatic discharge (ESD)	IEC 61000-4-2	4kV Contact 8kV Air	A
	Radiated EM field	IEC 61000-4-3	80 to 1000 MHz @ 10V/m with 1 kHz AM at 80% 1400 to 2000 MHz @ 3V/m with 1 kHz AM at 80% 2000 to 2700 MHz @ 1V/m with 1 kHz AM at 80%	A
I/O signal/control	Burst (fast transients)	IEC 61000-4-4	1 kV	A
	Surge	IEC 61000-4-5	1 kV (line to ground only, each)	A
	Conducted RF	IEC 61000-4-6	150 kHz to 80 MHz at 3 Vrms	A
Specification limit = ±1% of span 1. A=No degradation during testing. B = Temporary degradation during testing, but is self-recovering.				

Table 3. Maximum Steady-State Flow Rate (Air)

SUPPLY PRESSURE		OUTPUT PRESSURE		STEADY STATE FLOW RATE ⁽¹⁾	
Bar	Psi	Bar	Psi	m ³ /hr	Scfh
1.4	20	0.2 - 1.0	3 - 15		
		0.2	3	0.04	1.5
		0.62	9	0.06	2.0
		1.0	15	0.07	2.6
2.4	35	0.4 - 2.0	6 - 30		
		0.4	6	0.05	1.7
		1.2	18	0.08	2.9
		2	30	0.12	4.1
2.6	38	0.1 - 2.3	2 - 33		
		0.1	2	0.04	1.5
		1.2	17.5	0.08	2.9
		2.3	33	0.12	4.3

1. Normal m³/hour - Normal cubic meters per hour (0C and 1.0135 bar, absolute).
Scfh - Standard cubic feet per hour (60F and 14.7psig).

Table 4. Maximum Steady-State Flow Rate (Natural Gas)

SUPPLY PRESSURE		OUTPUT PRESSURE		STEADY STATE FLOW RATE ^(1,2)	
Bar	Psi	Bar	Psi	m ³ /hr	Scfh
1.4	20	0.2 - 1.0	3 - 15		
		0.2	3	0.06	1.95
		0.62	9	0.07	2.6
		1.0	15	0.1	3.38
2.4	35	0.4 - 2.0	6 - 30		
		0.4	6	0.6	2.21
		1.2	18	0.11	3.77
		2	30	0.15	5.33
2.6	38	0.1 - 2.3	2 - 33		
		0.1	2	0.06	1.94
		1.2	17.5	0.11	3.74
		2.3	33	0.18	5.55

1. Normal m³/hour - Normal cubic meters per hour (0C and 1.0135 bar, absolute).
Scfh - Standard cubic feet per hour (60F and 14.7psig).
2. Natural gas steady state flow based on natural gas specific gravity of 0.6.
Flow decreases as specific gravity increases.

Figure 2. Output-Time Relationships for Fisher i2P-100 Transducer

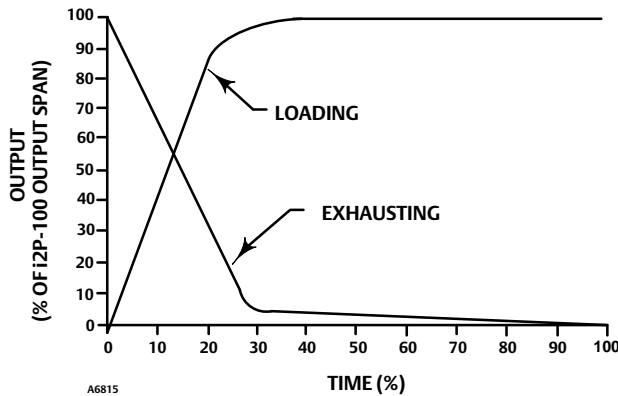

Installation

The i2P-100 transducer has been designed and approved for use with either air or natural gas as the supply medium. If using natural gas as the pneumatic supply medium, natural gas will be used in the pneumatic output connections of the transducer to any connected equipment. In normal operation the unit will vent the supply medium into the surrounding atmosphere unless it is remotely vented. When using natural gas as the supply medium, in a non-hazardous location in a confined area, remote venting of the unit is required. Failure to do so could result in personal injury, property damage, and area re-classification. For hazardous locations remote venting of the unit may be required, depending upon the area classification, and as specified by the requirements of local, regional, and federal codes, rules and regulations. Failure to do so when necessary could result in personal injury, property damage, and area re-classification.

Additional information for installation and safe use in hazardous locations can be found in the related instruction manual supplements as indicated in Hazardous Area Classifications and Special Instructions for “Safe Use” and Installation in Hazardous Locations on page 7.

⚠ WARNING

To avoid personal injury or property damage from the sudden release of pressure, air, or natural gas:

- Always wear protective clothing, gloves, and eyewear when performing any installation operations.
- If installing into an existing application, also refer to the **WARNING** at the beginning of the Maintenance section of this instruction manual.
- Check with your process or safety engineer for any additional measures that must be taken to protect against process media.

NOTICE

Do not use sealing tape on pneumatic connections. This instrument contains small passages that may become obstructed by detached sealing tape. Thread sealant paste should be used to seal and lubricate pneumatic threaded connections.

⚠ WARNING

This unit vents the supply medium into the surrounding atmosphere. When installing this unit in a non-hazardous (non-classified) location in a confined area, with natural gas as the supply medium, you must remotely vent this unit to a safe location. Failure to do so could result in personal injury or property damage from fire or explosion, and area re-classification.

When installing this unit in a hazardous (classified) location remote venting of the unit may be required, depending upon the area classification, and as specified by the requirements of local, regional, and federal codes, rules and regulations. Failure to do so when necessary could result in personal injury or property damage from fire or explosion, and area re-classification.

Vent line piping should comply with local and regional codes and should be as short as possible with adequate inside diameter and few bends to reduce case pressure buildup.

When received from the factory, the set screws (key 8), which provide a locking feature for the housing caps (key 2), are backed off approximately one turn. When using the i2P-100 transducer in explosive atmospheres these set screws must be fully engaged.

⚠ WARNING

When using this unit in explosive atmospheres, the set screws (key 8) must be fully engaged to lock/secure the housing caps. Failure to fully engage these set screws could result in unauthorized opening of the unit, which may result in personal injury or property damage caused by fire or explosion.

Hazardous Area Classifications and Special Instructions for “Safe Use” and Installation in Hazardous Locations

Refer to the following instruction manual supplements for approval information.

- CSA Approval Information for Fisher i2P-100 Electro-Pneumatic Transducer ([D104192X012](#))
- FM Approval Information for Fisher i2P-100 Electro-Pneumatic Transducer ([D104193X012](#))
- ATEX Approval Information for Fisher i2P-100 Electro-Pneumatic Transducer ([D104194X012](#))
- IECEx Approval Information for Fisher i2P-100 Electro-Pneumatic Transducer ([D104195X012](#))

All documents are available from your [Emerson sales office](#) or at Fisher.com. Contact your Emerson sales office for all other approval/certification information.

Mounting

When a transducer is ordered as part of a control valve assembly, the factory mounts the transducer on the actuator and connects the necessary tubing, then adjusts the transducer as specified on the order. See figures 3 and 4 for typical mounting configurations.

Figure 3. Fisher i2P-100 Electro-Pneumatic Transducer Mounted on a Size 30 667 Sliding-Stem Actuator

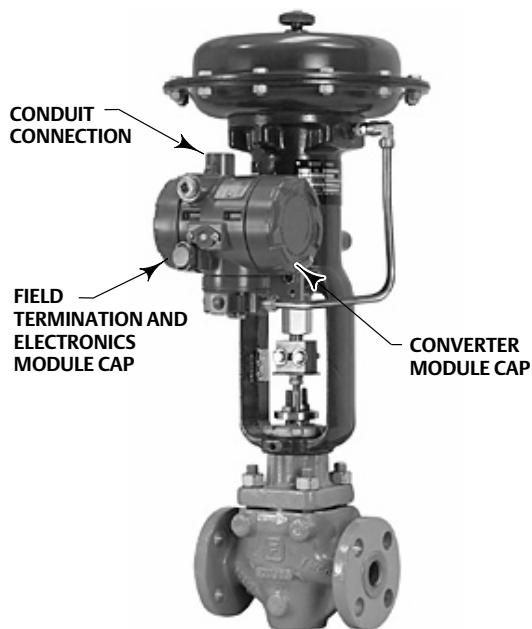

W8723

Figure 4. Fisher i2P-100 Electro-Pneumatic Transducer Mounted on a 2052 Rotary Actuator with 3610J Positioner and V300B Rotary Valve

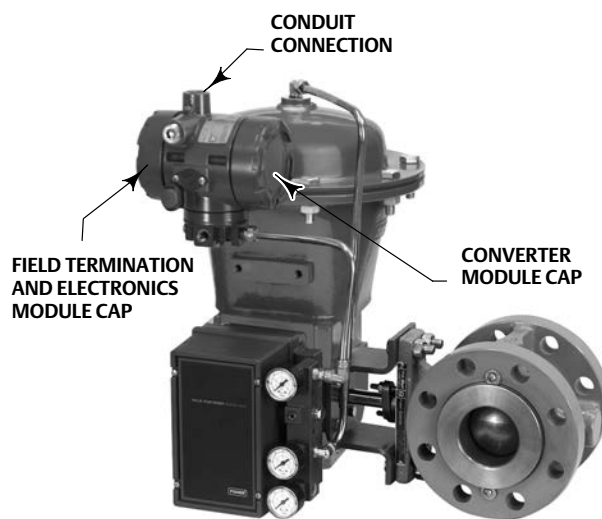

X1354

Transducers also can be ordered separately for mounting on a control valve assembly already in service, or for mounting on a 2 inch diameter pipestand, or a flat surface. The transducer may be ordered either with or without mounting parts.

Note

Do not mount the vent in a downward position as the vent will not drain properly and may become blocked with ice or debris, resulting in process instability.

Mounting parts include a mounting plate and bolts and, if ordered for pipestand mounting, a pipe clamp. Tubing is not included if the transducer is not factory mounted. Use 3/8-inch diameter tubing for all input and output connections. The length of tubing between the transducer output and the final control element should be as short as possible. Transducer overall dimensions are shown in figure 5. If weatherproofing is required, mount the transducer so that the vent can drain. Do not allow moisture or condensate to collect in the vent.

Pneumatic Connections

NOTICE

Do not use sealing tape on pneumatic connections. This instrument contains small passages that may become obstructed by detached sealing tape. Thread sealant paste should be used to seal and lubricate pneumatic threaded connections.

As shown in figure 5, all pressure connections on the transducer are 1/4 NPT internal connections. Use 3/8-inch tubing for all pressure connections. Refer to the vent subsection below for remote vent connections.

Figure 5. Dimensions and Connections

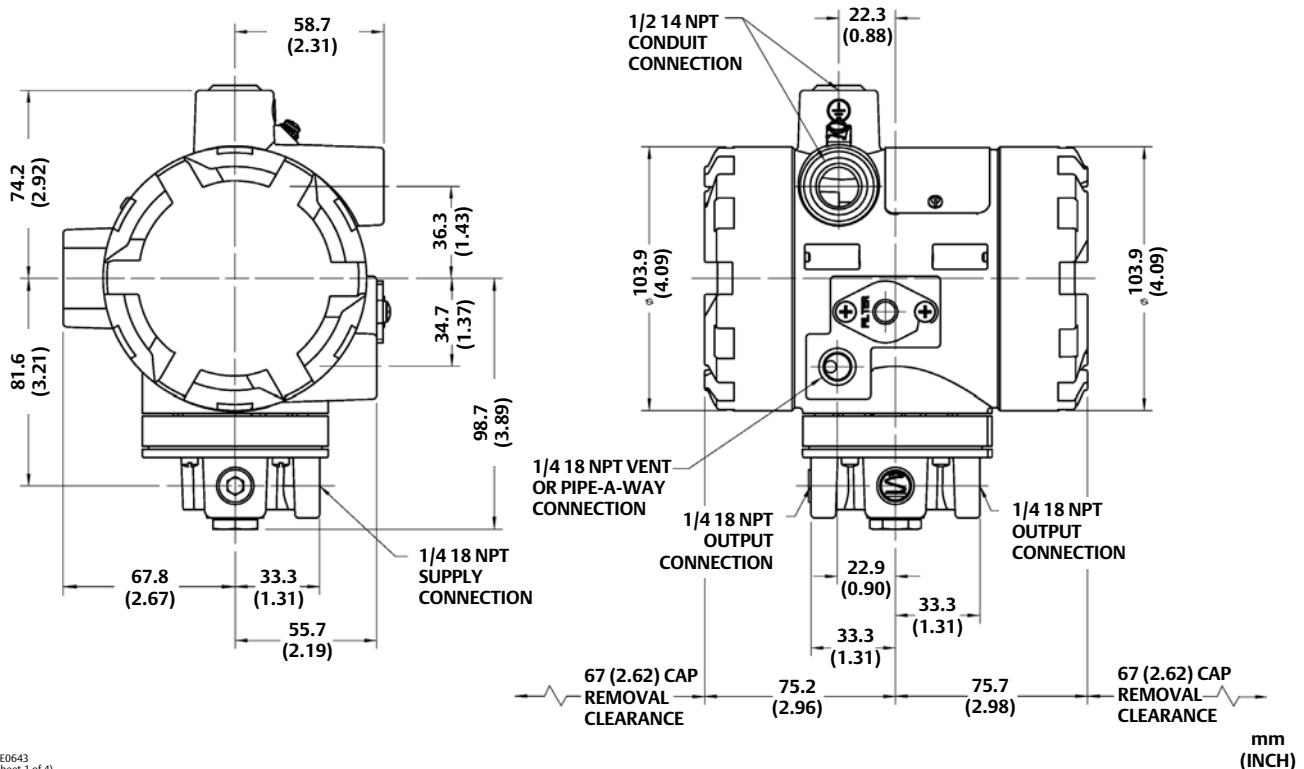

GE0643 (sheet 1 of 4)

Supply Pressure Requirements

⚠ WARNING

Severe personal injury or property damage could result from an unstable process if the instrument supply medium is not clean, dry, oil-free and noncorrosive. While use and regular maintenance of a filter that removes particles larger than 40 micrometers in diameter will suffice in most applications, check with an Emerson field office and industry instrument air quality standards for use with corrosive air or if you are unsure about the proper amount or method of air filtration or filter maintenance.

Supply pressure must be clean, dry air or noncorrosive gas. Use a Fisher 67CFR filter regulator with standard 5 micrometer filter, or equivalent, to filter and regulate supply air. The filter regulator can be mounted on a bracket with the transducer as shown in figure 6 or mounted on the actuator mounting boss. An output pressure gauge may be installed on the regulator to indicate the supply pressure to the transducer. Also, as an aid for calibration, a second gauge may be installed on the transducer to indicate transducer output pressure.

Connect the nearest suitable supply source to the 1/4 NPT IN connection on the filter regulator (if furnished) or to the 1/4 NPT SUPPLY connection on the transducer case (if the filter regulator is not attached).

Figure 6. Typical Fisher i2P-100 Mounting With 67CFR Filter Regulator

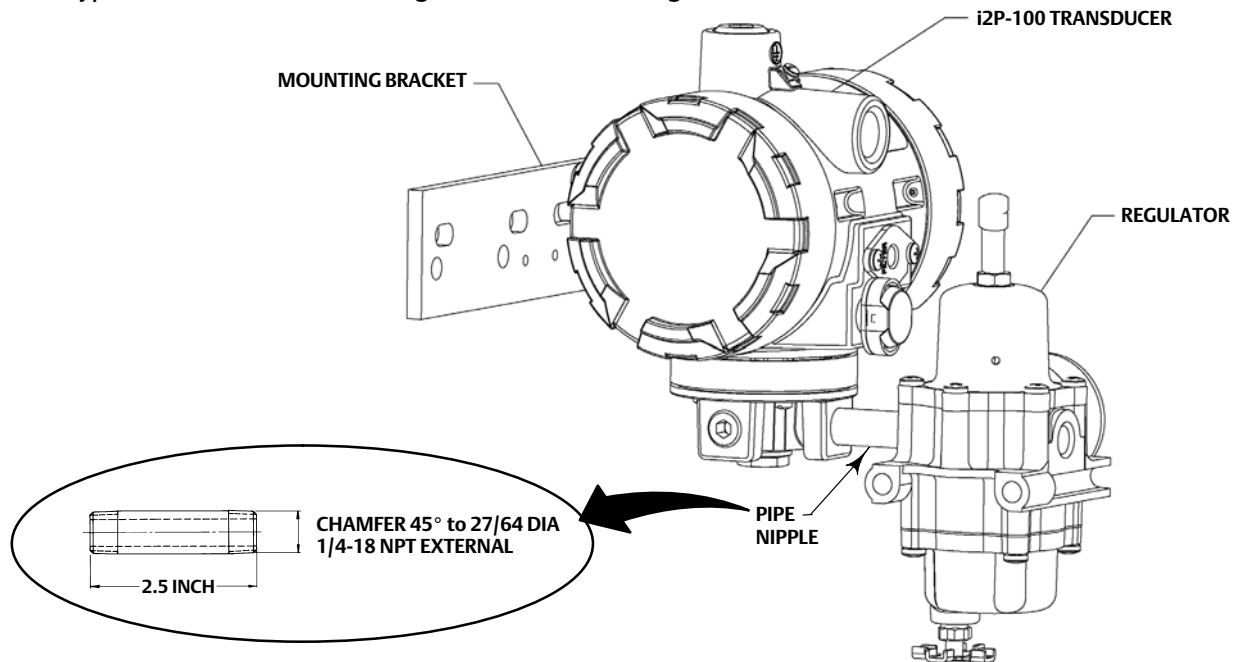

Diagnostic Connections

To support diagnostic testing of valve/actuator/positioner packages, special connectors and hardware are available. Typical connector installations are shown in figure 7. The hardware used includes a 1/4 NPT pipe nipple and pipe tee with a 1/8 NPT pipe bushing for the connector. The connector consists of a 1/8 NPT body and body protector.

Figure 7. Diagnostics Hookup for Fisher i2P-100 Transducer

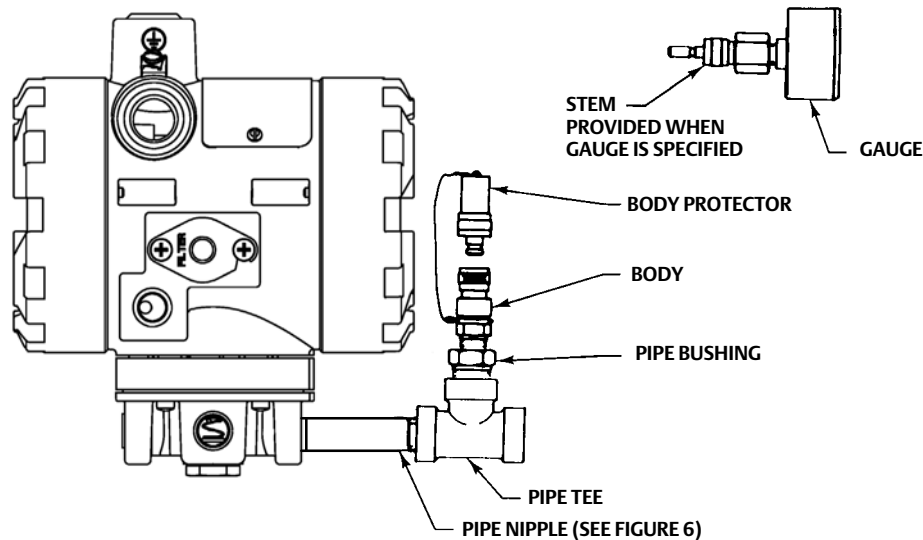

GE06439-A
(sheet 1 of 4)
B2395-1

Note

If the i2P-100 transducer is used in a valve assembly with a positioner, no hook-up for diagnostic testing is required for the i2P-100. The hook-up for diagnostic testing should be installed at the positioner.

Install the connectors and hardware between the i2P-100 transducer and the actuator.

1. Before assembling the pipe nipple, pipe tee, pipe bushings, actuator piping, and connector body, apply sealant to all threads.
2. Turn the pipe tee to position the connector body and body protector for easy access when doing diagnostic testing.

Vent

When using natural gas as the supply medium ensure that the following warnings are read and understood. Contact your [Emerson sales office](#) if you have any questions regarding the information contained in this section.

⚠ WARNING

This unit vents the supply medium into the surrounding atmosphere. When installing this unit in a non-hazardous (non-classified) location in a confined area, with natural gas as the supply medium, you must remotely vent this unit to a safe location. Failure to do so could result in personal injury or property damage from fire or explosion, and area re-classification.

When installing this unit in a hazardous (classified) location remote venting of the unit may be required, depending upon the area classification, and as specified by the requirements of local, regional, and federal codes, rules and regulations. Failure to do so when necessary could result in personal injury or property damage from fire or explosion, and area re-classification.

Vent line piping should comply with local and regional codes and should be as short as possible with adequate inside diameter and few bends to reduce case pressure buildup.

If a remote vent is required, the vent line must be as short as possible with a minimum number of bends and elbows. To connect a remote vent, remove the plastic vent (key 71, figure 13). The vent connection is 1/4 NPT internal. Use 3/8-inch tubing to provide a remote vent.

Electrical Connections

⚠ WARNING

For explosion-proof applications, or when using natural gas as the supply medium, disconnect power before removing the housing cap. Personal injury or property damage from fire or explosion may result if power is not disconnected before removing the cap.

For intrinsically safe installations, refer to the nameplate or to instructions provided by the barrier manufacturer for proper wiring and installation.

Note

For North American explosion-proof applications in the Class/Division system, the i2P-100 has been designed such that a conduit seal is not required. For all other applications install the product as per local, regional, or national code, rules, and regulations.

⚠ WARNING

Select wiring and/or cable glands that are rated for the environment of use (such as hazardous location, ingress protection, and temperature). Failure to use properly rated wiring and/or cable glands can result in personal injury or property damage from fire or explosion.

Wiring connections must be in accordance with local, regional, and national codes for any given hazardous area approval. Failure to follow the local, regional, and national codes could result in personal injury or property damage from fire or explosion.

Use the 1/2 NPT conduit connection, shown in figure 5, for installation of field wiring.

Refer to figures 8, 9, and 10 when connecting field wiring from the control device to the transducer. Connect the positive wire from the control device to the transducer “+” terminal and, the negative wire from the control device to the transducer “-” terminal. Do not overtighten the terminal screws. Maximum torque is 0.45 N•m (4 lbf•in.). Connect the transducer grounding terminal to earth ground.

Grounding terminals are provided both inside and outside the transducer housing.

Figure 8. Typical Field Wiring Diagram

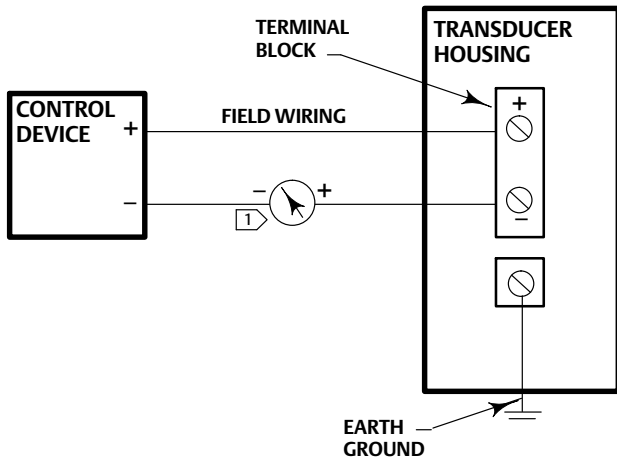

NOTE:
 1 FOR TROUBLESHOOTING OR MONITORING OPERATION, AN INDICATING DEVICE CAN BE A VOLTMETER ACROSS A 250 OHM RESISTOR OR A CURRENT METER.

A3875

Figure 9. Equivalent Circuit

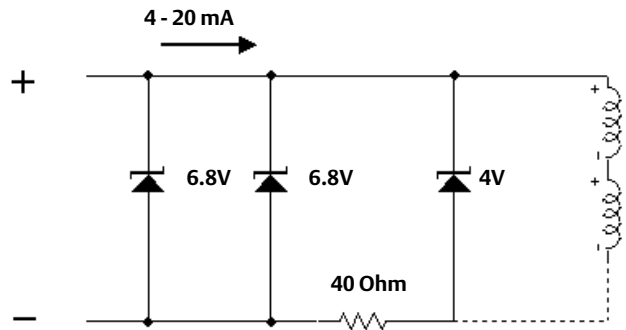

Operating Information

During normal operation, the output of the i2P-100 transducer is connected to the final control element.

Calibration

⚠ WARNING

On explosion-proof instruments, or when using natural gas as the supply medium, remove electrical power before removing either of the housing caps in a hazardous area. Personal injury or property damage may result from fire or explosion if power is applied to the transducer with the cap removed in a hazardous area.

For intrinsically safe areas, current monitoring during operation must be with a meter approved for use in hazardous areas.

Equipment Required

Choose a current or voltage source that is capable, without switching ranges, of driving the transducer through its entire input range. Switching ranges on a current or voltage source will produce spikes or mid-scale reverses in the input signal presented to the transducer, causing errors. The current source should be capable of delivering 30 mA with 30 VDC maximum compliance voltage.

Calibration Procedure

⚠ WARNING

To avoid personal injury or property damage due to an uncontrolled process provide some temporary means of process control before beginning the calibration procedure.

Refer to figure 10 for adjustment locations.

Figure 10. Zero and Span Adjustments and Switch Settings

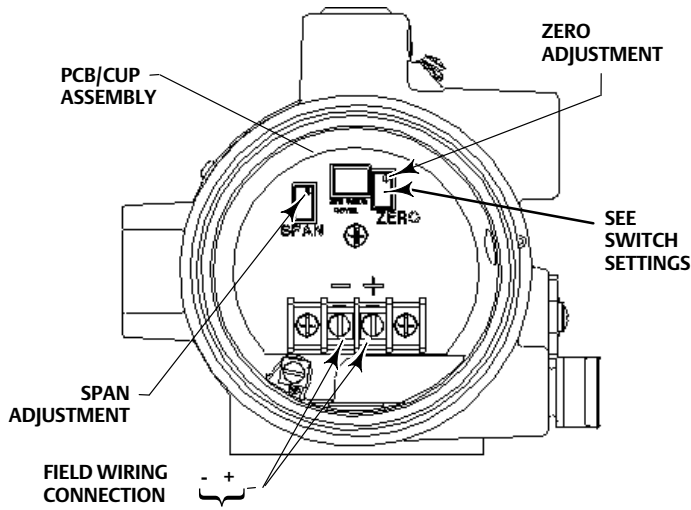

SWITCH SETTINGS⁽³⁾

SETTING A	SETTING B ^(1,2)	SETTING C ⁽¹⁾
4-20 mA 3-15 psi	4-12 mA 3-15 psi 4-20 mA 6-30 psi 4-20 mA 2-33 psi	12-20 mA 3-15 psi

NOTES:

THE SWITCH SETTINGS WILL PRODUCE THE PERFORMANCE CHARACTERISTICS AS INDICATED. FOR EXAMPLE, BOTH SWITCHES PLACED IN THE OFF POSITION WILL CREATE A 4-20 mA INPUT WITH A 3-15 PSIG OUTPUT PERFORMANCE CHARACTERISTIC

1. INPUT SIGNAL SPLIT RANGE IS SELECTABLE VIA DIP-SWITCH CONFIGURATION.
2. OUTPUT RANGE DIP-SWITCH SELECTION FOR 0.14 TO 2.0 BAR (2 TO 33 PSIG) USES SETTING B AND REQUIRES ZERO TO SPAN ADJUSTMENTS. FOR OTHER RANGES, ZERO AND SPAN ADJUSTMENTS NEEDED.
3. SWITCH 1 SET TO THE ON POSITION AND SWITCH 2 SET TO THE OFF POSITION IS NOT A VALID SWITCH SETTING.

GE03345

Note

The following steps are for a 4-20 mA, 0.2 to 1.0 bar (3 to 15 psig) configured unit. The same procedure is used for other configurations.

1. Remove electronics module cover (cover adjacent to conduit entry, see figure 3 and 4).

NOTICE

Do not attempt to remove either of the housing caps if the locking set screws (key 8) are engaged. Removing housing caps without disengaging the set screws can cause damage to the housing caps.

2. Input and output ranges are selectable by dip switch selection. Refer to figure 10 for dip switch settings. Adjust dip switch settings and zero and span as necessary to achieve the desired input/output range.
3. If a current source other than the control device is used as the input source, disconnect the control device and connect the current source positive terminal to the transducer “+” terminal and the current source negative terminal to the transducer “-” terminal.
If an external meter is used, connect the current source positive terminal to the transducer “+” terminal. Connect the meter positive terminal to the transducer “-” terminal and the meter negative terminal to the current source negative terminal as shown in figure 8.
4. Check the supply pressure to ensure it is at the recommended pressure. Refer to table 1, the Specifications table, for supply pressure recommendations.

5. Adjust the input current to the low mA DC.
6. The output pressure should be 0.2 bar (3 psig). If not, adjust the ZERO potentiometer until the output pressure is 0.2 bar (3 psig).
7. Adjust the input current to the high mA DC.
8. The output pressure should be 1.0 bar (15 psig). If not, adjust the SPAN potentiometer until the output pressure is 1.0 bar (15 psig).
9. Repeat steps 5 through 8 until the output pressure is within the referenced accuracy requirements without further adjustment.
10. If a current source other than the control device was used, disconnect the current source and reconnect the control device.

Principle of Operation

The converter module receives a standard DC current input signal from a control device to operate coils in a force balanced beam system which in turn, controls bleed air through an integral nozzle/flapper arrangement. The nozzle pressure provides the input signal to operate the relay as shown in figure 11. Relay output pressure is applied, through tubing, directly to the final control element or valve/actuator assembly.

Figure 11. Fisher i2P-100 Transducer Schematic

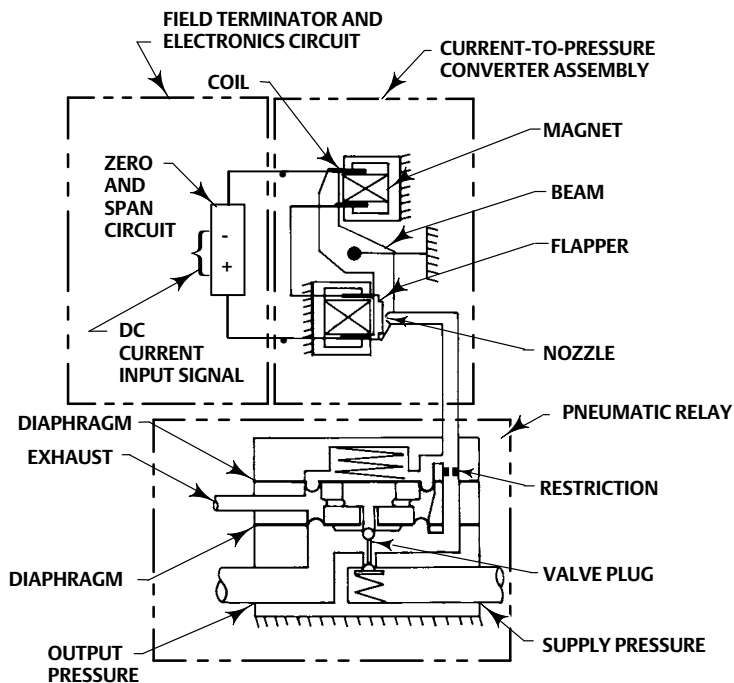

A3877-2

Maintenance

Due to normal wear or damage from external sources such as debris in the supply medium, periodic maintenance or repair of the transducer may be necessary. Maintenance of the transducer consists of troubleshooting, removal for

inspection, and replacement of component parts, as well as removal and inspection of the external removable filter/restriction and cleaning or replacing as necessary (see figure 1).

⚠ WARNING

To avoid personal injury or property damage from the sudden release of pressure, air or natural gas:

- Always wear protective clothing, gloves, and eyewear when performing any maintenance operations.
- Do not remove the actuator from the valve while the valve is still pressurized.
- Disconnect any operating lines providing air pressure, electric power, or a control signal to the actuator. Be sure the actuator cannot suddenly open or close the valve.
- Use bypass valves or completely shut off the process to isolate the valve from process pressure. Relieve process pressure on both sides of the valve.
- Use lock-out procedures to be sure that the above measures stay in effect while you work on the equipment.
- Check with your process or safety engineer for any additional measures that must be taken to protect against process media.

⚠ WARNING

When using natural gas as the supply medium, or for explosion proof applications, the following warnings also apply:

- Remove electrical power before removing either housing cap. Personal injury or property damage from fire or explosion may result if power is not disconnected before removing either cap.
- Remove electrical power before disconnecting any of the pneumatic connections or removing the external removable filter/restriction.

When disconnecting any of the pneumatic connections or the external removable filter/restriction, natural gas will seep from the unit and any connected equipment into the surrounding atmosphere. Personal injury or property damage may result from fire or explosion if preventative measures are not taken, such as adequate ventilation and the removal of any ignition sources.

NOTICE

Do not attempt to remove either of the housing caps if the locking set screws (key 8) are engaged. Removing housing caps without disengaging the set screws can cause damage to the housing caps.

⚠ WARNING

When replacing components, use only components specified by the factory. Always use proper component replacement techniques, as presented in this manual. Improper techniques or component selection may invalidate the approvals and the product specifications, as indicated in table 1. It may also impair operations and the intended function of the device and could cause personal injury and property damage.

The converter module and the electronics module are non-repairable. If troubleshooting or alignment attempts indicate a faulty converter or electronics module, replace the module or return the transducer to your [Emerson sales office](#) for repair.

Troubleshooting

The following procedures require taking the control valve/actuator assembly out of service. Provide some temporary means of process control before taking the control valve out of service.

Electrical

1. Ensure terminal lug connections from the control device to the transducer are of the correct polarity (refer to the electrical connection procedures in the Installation section of this manual).
2. At the transducer, ensure that the mA DC signal is applied, and ensure that it is within the 4 to 20 mA range.
3. Check switches and ensure that they are properly set. Refer to figure 10.
4. If the problem has not been resolved, see Electronics Module Replacement in this manual.

Pneumatic

Provide a 4-30 mA DC current source, supply pressure, and a gauge to monitor the output pressure when checking transducer operation. Refer to figure 13 for key number locations.

1. Ensure that supply pressure to the transducer meets your requirements [0.3 bar (5 psi) higher than upper range limit of output signal, with a maximum of 3.4 bar (50 psi)].
2. Ensure that the filter (key 11), gasket (key 106), and restrictor (key 10) are open and clean. Remove the two screws (key 14), the filter cap (key 13), and the O-ring (key 12) to access the filter, gasket, and restrictor.
3. If a filter/regulator is used, ensure that it is working correctly. If not, ensure the dripwell is not plugged because of excessive moisture accumulation. If necessary, drain off any moisture, and clean or replace the filter element.
4. Force the converter module to maximum output pressure with a 30 mA DC signal. Output pressure should build up to the approximate value of the supply pressure [maximum of 3.4 bar (50 psi)].
5. When the input current is removed, the transducer output pressure should drop to less than 0.14 bar (2 psig). If it does not, check to ensure the vent and exhaust air passageway is free from foreign material.
6. To inspect the relay assembly, refer to the Relay Maintenance procedures in this manual.
7. If the problem has not been resolved, see Converter Module Replacement in this manual.

Converter Module Replacement

Removal

Refer to figure 13 for key number locations.

1. Disconnect operating lines providing air pressure, electric power, or a control signal to the actuator. If using gas as the supply medium remove electrical power before removing the housing cap.
2. Remove the housing cap (key 2) (the cap farthest away from the conduit). Note that the set screw associated with this housing cap (key 8) needs to be loosened to remove the cap.
3. Unscrew the two captive screws (key 52) and remove the converter module from the housing.
4. Inspect the O-ring (key 55) and replace if necessary.

Replacement

1. Lubricate the O-ring (key 55) with a silicone sealant before replacing the converter module in the housing.
2. Insert the converter module into position in the housing (key 1). Replace the two screws (key 52) and tighten them.
3. Replace the housing cap (key 2), making sure to re-tighten the set screw (key 8).
4. Electrically calibrate the unit using the procedure in the Calibration section of this manual.

Electronics Module Replacement

Removal

Refer to figure 13 for key number locations.

1. Disconnect operating lines providing air pressure, electric power, or a control signal to the actuator. If using gas as the supply medium remove electrical power before removing the housing cap.
2. Remove the housing cap (key 2) (the cap closest to the conduit). Note that the set screw (key 8) associated with this housing cap needs to be loosened to remove the cap.
3. Note the location of the wires, then remove the electrical wiring from the terminal block.
4. Remove the three screws (key 26) and remove the electronics module from the housing.

Replacement

1. Insert the electronics module into position in the housing (key 1). Replace the three screws (key 26) and tighten them.
2. Replace the electrical wiring removed in step 1 of the removal procedures. Do not overtighten the terminal screws. Maximum torque is 0.45 N•m (4 lbf•in).
3. Electrically calibrate the unit using the procedure in the Calibration section of this manual.
4. Replace the housing cap (key 2), making sure to re-tighten the set screw (key 8).

Relay Maintenance

Refer to figures 12 and 14 for key number locations.

Figure 12. Valve Plug, Inner Valve Spring and Body Plug Assembly

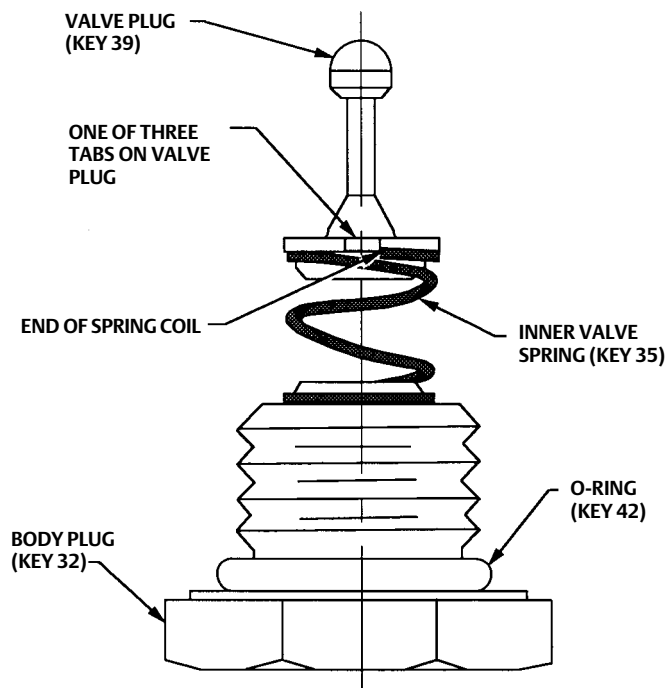

A6057-1

Removal

1. Remove the four mounting screws (key 36, shown in figure 14) and remove the relay from the transducer. Be careful not to lose the bias spring (key 34) and input diaphragm (key 38).
2. Remove the body plug (key 32) that holds the inner valve spring (key 35) and valve plug (key 39) in place from the relay body assembly.
3. Remove the exhaust port assembly (key 33) from the relay assembly.
4. Inspect the springs, exhaust seat, valve plug, and other parts for wear or damage; replace as necessary. Note: the valve plug supply seat is an insert in the relay body (key 41). If this insert is bad, replace the relay body.
5. Make sure all parts of the relay are clean and that all passages are clear of foreign matter.

Assembly

Note

The relay will not function properly if the tabs on the body block and the relay body are not aligned as specified with the transducer housing assembly in the following procedure.

1. Assemble the inner valve spring (key 35) onto the body plug (key 32) and fit the valve plug (key 39) onto the inner valve spring as shown in figure 12. To assure best alignment between the valve plug, inner valve spring, and body plug; fit the valve plug onto the inner valve spring so that one of the three tabs at the base of the valve plug sets at the end of the last coil of the inner valve spring.
2. Lubricate the O-ring (key 42) with a silicone sealant (key 37). Insert the assembled valve plug, inner valve spring, and body plug into the relay body (key 41). Compress the spring and thread the body plug (key 5) into place. Then, tighten the body plug.
3. Insert two of the mounting screws (key 36) into two opposite holes of the relay body (key 41). Hold the screws in place while assembling the following parts on the relay body. The screws serve as studs to align the parts as they are being assembled.
4. When replacing the exhaust port assembly (key 33), make sure all passages and screw holes are aligned and that the hole in the center of the exhaust port assembly fits over the valve plug (key 39). Place the exhaust port assembly on the relay body (key 41). Hold assembled parts in place.
5. Make sure the tabs on the body block (key 40) align with the tabs on the relay body (key 41) and that the side with 5 holes faces the relay body. Place the body block on the assembled parts. Hold assembled parts in place.
6. When replacing the input diaphragm (key 38), make sure all passages and screw holes are aligned. Place the input diaphragm on the body block (key 40). Hold assembled parts in place.
7. Install the bias spring (key 34) into the transducer housing assembly (key 1). Make sure the tabs on the body block and relay body align with the tab on the transducer housing assembly. Place the assembled parts onto the transducer housing assembly. Thread the two mounting screws (key 36) into the transducer housing assembly. Install the remaining two mounting screws. Tighten all mounting screws to 2 N•m (20 lbf•in).
8. Perform the procedure in the Calibration section of this manual.

Parts Ordering

A serial number is assigned to each transducer and stamped on the nameplate. Always refer to this serial number when corresponding with your [Emerson sales office](#) regarding spare parts or technical information.

⚠ WARNING

Use only genuine Fisher replacement parts. Components that are not supplied by Emerson should not, under any circumstances, be used in any Fisher instrument. Use of components not supplied by Emerson may void your warranty, might adversely affect the performance of the instrument, and could cause personal injury and property damage.

Parts Kits

Description	Part Number	Description	Part Number
Repair Kit for i2P-100 electro-pneumatic transducer Contains O-rings (key 4, 9, 12, and 55) and Filter/Gasket/Restrictor assembly (key 10, 11, and 106)	R2P100X0032	Upgrade Kit for i2P-100 electro-pneumatic transducer w/Electronics Module for PWB/Cup Assembly Contains O-rings (key 4, 9, 12, and 55) Filter/Gasket/Restrictor assembly (key 10, 11, and 106), and PWB/Cup Assembly (key 24)	R2P100X0042

Note:

Transducers Ordered Prior to November 2013

If you have not yet updated your PWB/Cup Assembly (key 24) and require the low bleed 0.14 to 2.3 bar (2 to 33 psig) range you must update your PWB/Cup Assembly using upgrade kit R2P100X0042.

Figure 13. Fisher i2P-100 Transducer Assembly

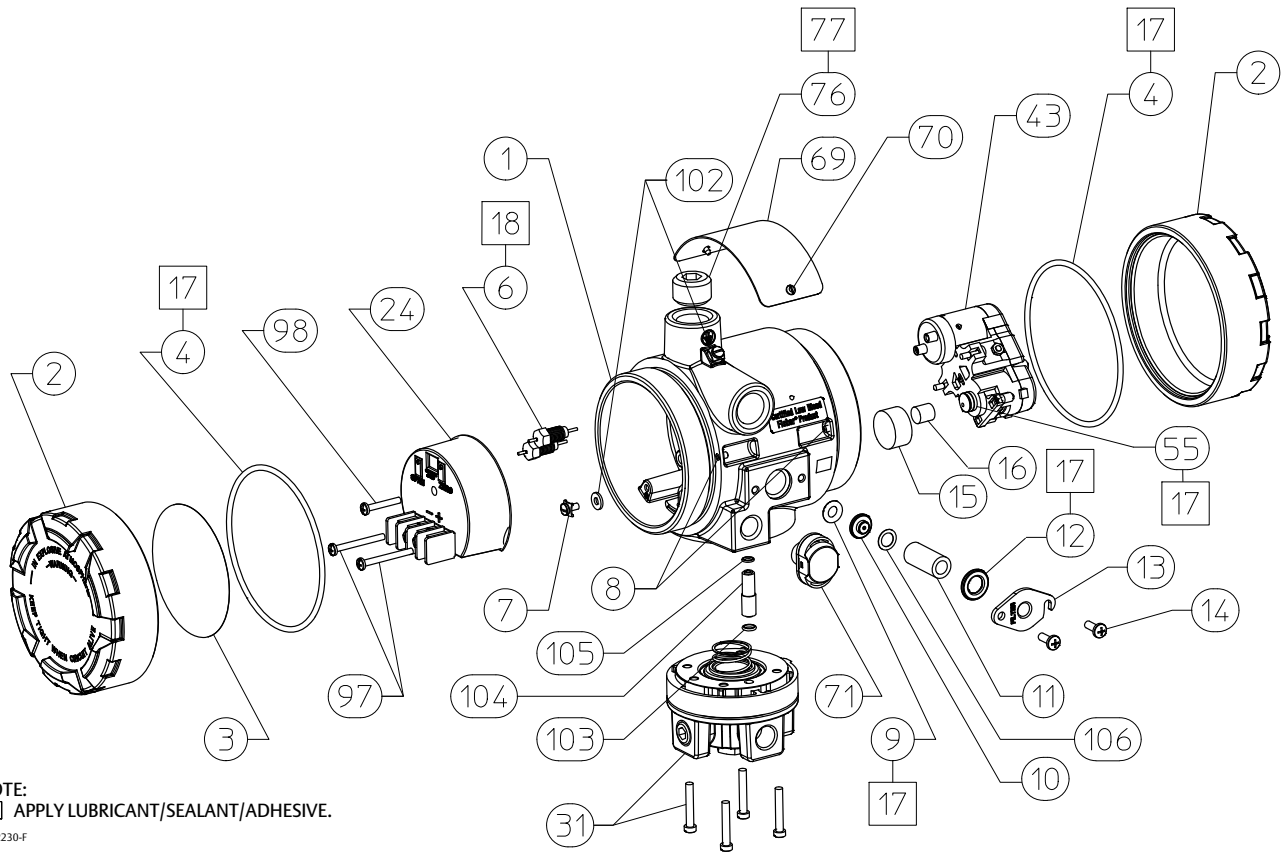

NOTE:
 □ APPLY LUBRICANT/SEALANT/ADHESIVE.
 30C2230-F

Parts List (see figure 13)

Note

Contact your [Emerson sales office](#) for Part Ordering information.

Housing

Key	Description
1	Housing
2	Cover (2 req'd)
3	Configuration Label
4*	O-Ring ⁽¹⁾ (2 req'd)
6	Feed Thru (2 req'd)

Key	Description
7	Wire Retainer (2 req'd)
8	Set Screw (2 req'd)
9*	O-Ring ⁽¹⁾
10	Restrictor, Primary ⁽¹⁾
11*	Filter ⁽¹⁾
12*	O-Ring ⁽¹⁾
13	Filter Cap
14	Machine Screw (2 req'd)
15	Flame Arrestor
16	Flame Arrestor
17	Lubricant, silicone sealant (not furnished with transducer)
18	Thread locking adhesive, high strength (not furnished with transducer)
24	Nameplate
31	Screws
43	Vent Assembly
55	O-Ring ⁽¹⁾
69	Washer
70	Screw (2 req'd)
71	Gasket
76	Pipe Plug
102	Washer
106	Gasket ⁽¹⁾

*Recommended spare parts
 1. Available in the Repair Kit

Figure 14. Fisher i2P-100 Relay Assembly

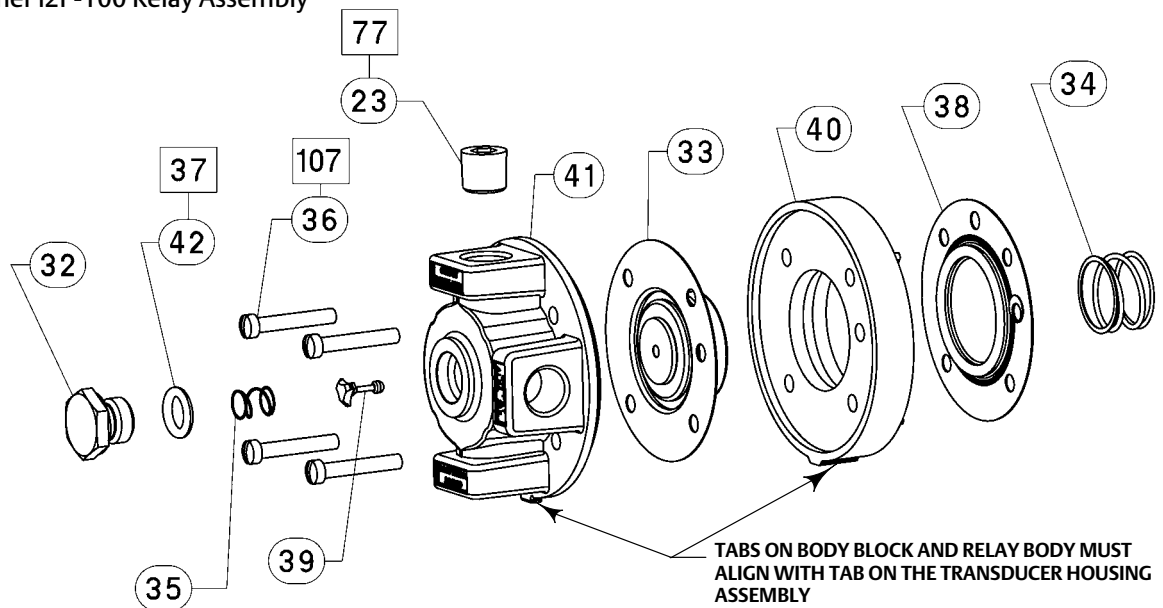

NOTE:
□ APPLY LUBRICANT/SEALANT/ADHESIVE

30C2258-C

Key Description

PWB/Cup Assembly

- 24 PWB/Cup Assembly
- 97 Machine Screw (2 req'd)
- 98 Machine Screw

Relay Assembly (see figure 14)

- 32 Body Plug
- 33 Exhaust Port Assembly
- 34 Spring
- 35 Spring
- 36 Machine Screw, fill hd (4 req'd)
- 37 Lubricant, silicone sealant (not furnished with relay)
- 38* Upper Diaphragm
- 39* Valve Plug
- 40 Body Block
- 41 Relay / Body Assembly
- 42* O-Ring
- 77 Anti-Seize Sealant (not furnished with relay)
- 107 Thread Locking Adhesive (medium strength) (not furnished with relay)

I/P Converter Assembly

- 43 I/P Converter Assembly

Gauge/Pipe Plug

- 23 Pipe plug, use when gauge is not specified (not shown)
- 23* Gauge, (not shown)
 - 0-30 psig/0-0.2 MPa/0-2 bar
 - 0-60 psig/0-0.4 MPa/0-4 bar

Diagnostic Connections

Key Description

- FlowScanner™ diagnostic system hook-up
Includes pipe tee, pipe nipple, pipe bushings, connector body, and body protector. See figure 7 for part identification.

Note

If the i2P-100 transducer is used in a valve assembly with a positioner, no hook-up for diagnostic testing is required for the i2P-100. The hook-up for diagnostic testing should be installed at the positioner.

Side Output

- For units with gauges
- For units without gauges

Key Description

Mounting Parts

Note

Contact your [Emerson sales office](#) for information on ordering the following i2P-100 mounting options.

Yoke Mounting

470 size 23 through 64
80 Mounting Bracket,
81 Washer (4 req'd)
82 Cap Screw (4 req'd)

480 Series actuator boss
80 Mounting Bracket
81 Washer pl (4 req'd)
82 Cap Screw (4 req'd)
83 Screw (2 req'd)
85 Mounting Bracket
86 Hex Nut (2 req'd)

585C size 25 and 50
80 Mounting Bracket
81 Washer (4 req'd)
82 Cap Screw (4 req'd)
83 Screw (2 req'd)

585C (470) size 60, 68, 100, and 130 ; 657 and 667 size 30, 34, 40, 45, 50, 60, 70, 80 & 87; 1051 and 1052 size 40, 60 and 70; 1061 all sizes
80 Mounting Bracket
81 Washer (4 req'd)
82 Cap Screw (4 req'd)
83 Screw (2 req'd)
84 Spacer

Key Description

Casing Mounting

657 and 667 size 30, 34, 40, 45, 50 and 60
80 Mounting Bracket
81 Washer (2 req'd)
82 Cap Screw (2 req'd)
83 Screw (2 req'd)

657 and 667 size 70
80 Mounting Bracket
81 Washer (2 req'd)
82 Cap Screw (2 req'd)
83 Screw (2 req'd)

1051 and 1052 size 20, 33, 40, 60 and 70
80 Mounting Bracket
81 Washer (2 req'd)
82 Cap Screw (2 req'd)
83 Screw (req'd)

1250 and 1250R all sizes
80 Mounting Bracket
81 Washer (2 req'd)
82 Cap Screw (2 req'd)
87 Washer
91 U-Bolt (2 req'd)
92 Hex Nut (req'd)

Pipestand Mounting

80 Mounting Bracket
81 Washer (4 req'd)
82 Cap Screw (2 req'd)
88 Pipe Clamp

Surface Mounting

80 Mounting Bracket
82 Cap Screw

Neither Emerson, Emerson Automation Solutions, nor any of their affiliated entities assumes responsibility for the selection, use or maintenance of any product. Responsibility for proper selection, use, and maintenance of any product remains solely with the purchaser and end user.

Fisher and FlowScanner are marks owned by one of the companies in the Emerson Automation Solutions business unit of Emerson Electric Co. Emerson Automation Solutions, Emerson, and the Emerson logo are trademarks and service marks of Emerson Electric Co. All other marks are the property of their respective owners.

The contents of this publication are presented for informational purposes only, and while every effort has been made to ensure their accuracy, they are not to be construed as warranties or guarantees, express or implied, regarding the products or services described herein or their use or applicability. All sales are governed by our terms and conditions, which are available upon request. We reserve the right to modify or improve the designs or specifications of such products at any time without notice.

Emerson Automation Solutions
Marshalltown, Iowa 50158 USA
Sorocaba, 18087 Brazil
Cernay, 68700 France
Dubai, United Arab Emirates
Singapore 128461 Singapore

www.Fisher.com



EMERSON[™]