



fitbit ace



User Manual
Version 1.41

Table of Contents

Get started	4
What's in the box	4
Set up Ace	5
Charge your tracker	5
See your data in the Fitbit app	6
Wear Ace	6
Placement	7
Handedness	7
Wear and care tips	7
Change the band	8
Remove a band	8
Attach a new band	9
Basics	10
Navigate Ace	10
Activity and Wellness	11
See your stats	11
Track your sleep	11
Set a sleep goal	11
Track a daily activity goal	12
Choose a goal	12
Track your hourly activity	12
Set an alarm	13
Notifications from your phone	14
Set up notifications	14
See incoming notifications	14
Change the clock face	15
Update Ace	16
Restart Ace	17

General Info and Specifications	18
Sensors and Components	18
Materials	18
Wireless technology	18
Haptic feedback	18
Memory	18
Display	19
Band size	19
Environmental conditions	20
Learn more	20
Return policy and warranty	20
Regulatory and Safety Notices	21
USA: Federal Communications Commission (FCC) statement	21
Canada: Industry Canada (IC) statement	22
European Union (EU)	23
Safety Statement	24
Australia and New Zealand	24
China	24
Mexico	25
Japan	25
Philippines	26
Singapore	26
South Africa	26
South Korea	27
Taiwan	28
United Arab Emirates	29
Index	31

Get started

Welcome to Fitbit Ace, the showerproof band designed for kids ages 8 and up that tracks steps, active minutes, and sleep and rewards kids for hitting goals.

Take a moment to review our complete safety information at [fitbit.com/safety](https://www.fitbit.com/safety). Ace is not intended to provide medical or scientific data.

What's in the box

Your Ace box includes:



Tracker



Additional large band



Charging cable

Set up Ace

Install the Fitbit app on the primary phone or tablet your child will use with Ace. Log in to or create your own Fitbit account. Next, create a family account and a child account. Connect Ace to your child's account to transfer (or sync) data to the Fitbit app. Detailed setup instructions are available in [the related help article](#).



To set up an account, you're prompted to enter information such as your child's height to help calculate their activity.

To use certain features and see all data collected by Ace, open kid view in the Fitbit app.

Charge your tracker

A fully-charged Ace has a battery life of 5 days. Battery life and charge cycles vary with use and other factors; actual results will vary.

To charge Ace:

1. Plug the charging cable into the USB port on your computer, a UL-certified USB wall charger, or another low-energy charging device.
2. Clip the other end of the charging cable to the port on the back of Ace. The pins on the charging clip must lock securely with the gold contacts on the back of the tracker. Ace vibrates, and a battery icon appears on the screen.

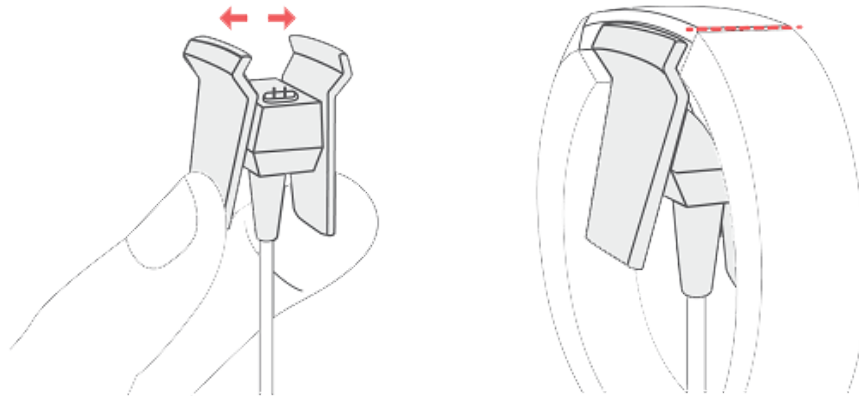

Charging fully takes up to 2 hours. While the tracker charges, tap it to check the battery level. A fully-charged tracker shows a solid battery icon. If you haven't set up Ace yet, you'll see a message instructing you to set up your tracker.

See your data in the Fitbit app

Open the Fitbit app on your phone to view your activity and sleep data; participate in challenges; and more.

Each time you open the Fitbit app in kid view, Ace syncs automatically when it's nearby. You can also use the **Sync Now** option in the app.

For more information, see [the related help article](#).

Wear Ace

Place Ace around your wrist. The top of the tracker is the side with the charging port. The top of the tracker should be on the outside or top of your wrist. If you purchased an accessory band, you'll find instructions in "[Change the band](#)" on [page 8](#).

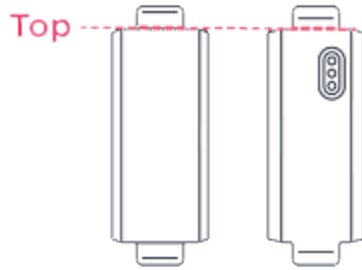



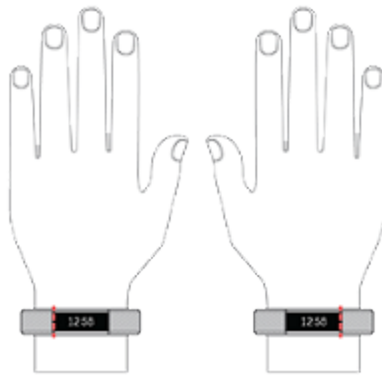

Placement

Wear Ace a finger's width above your wrist bone.



Handedness

For greater accuracy, you must specify whether you wear Ace on your dominant or non-dominant hand. Your dominant hand is the one you use for writing and eating. To start, the Wrist setting is set to non-dominant. If you wear Ace on your dominant hand, change the Wrist setting in the Fitbit app:

From the Today tab  in the Fitbit app, tap your profile picture  Ace tile  **Wrist**  **Dominant**.

Wear and care tips

- Clean your band and wrist regularly with a soap-free cleanser.
- If your tracker gets wet, remove and dry it completely after your activity.

- Take your tracker off from time to time.

For more information, visit the [Fitbit Wear & Care page](#).

Change the band

Ace comes with an extra small band attached and an additional large bottom band in the box. Both the top and bottom bands can be swapped with accessory bands, sold separately on [fitbit.com](https://www.fitbit.com). For band measurements, see "[Band size](#)" on [page 19](#).

Remove a band

1. Turn Ace over and find the band latches.
2. To release the latch, press down on the flat metal button on the strap.

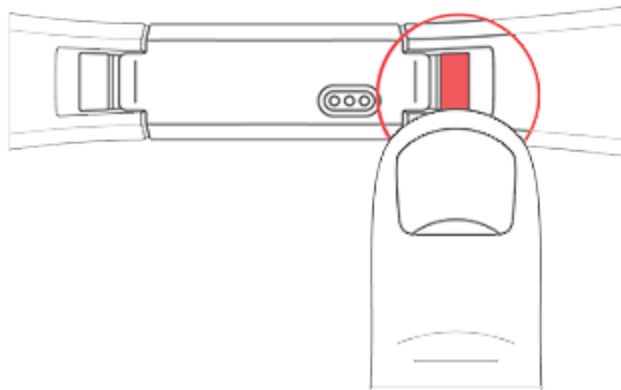

3. Slide the band up to release it from the tracker.

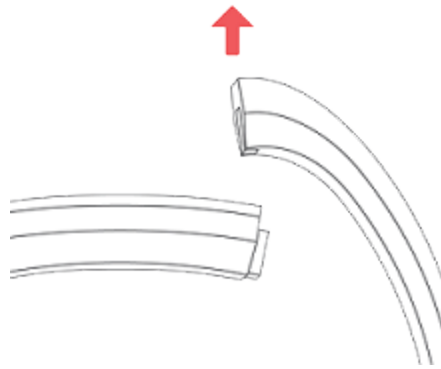

4. Repeat on the other side.

If you're having trouble removing the band or if it feels stuck, gently move the wrist band back and forth to release it.

Attach a new band

Before you attach a new band, first identify the top and bottom bands. The top band has a buckle on it and should be attached on the side closest to the charging port. The bottom band has notches in it.

To attach a band, slide it down on the end of the tracker until it snaps into place.

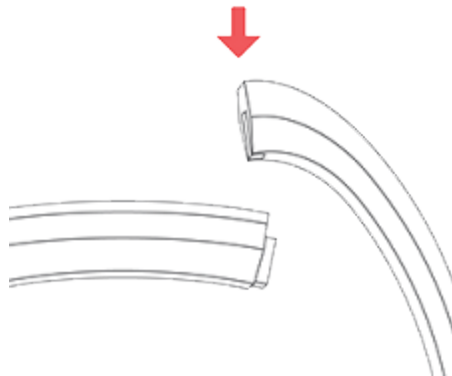

Basics

Learn how to navigate, check the battery level, and care for your child's tracker.

Navigate Ace

Ace has an OLED tap display that can be oriented horizontally or vertically. Tap the display to flip through your stats.

The screen on Ace is dimmed when not in use. It wakes up automatically when you turn your wrist or double-tap Ace where the screen meets the band.

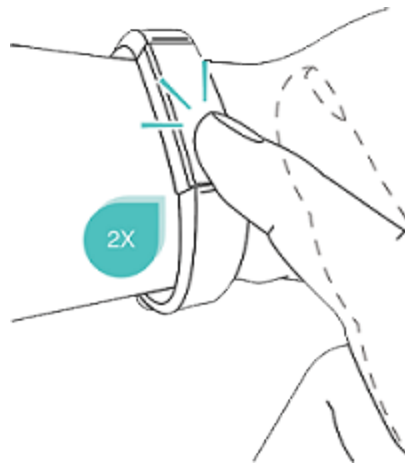

Activity and Wellness

Ace continuously tracks a variety of stats whenever you wear it. Data automatically syncs with the Fitbit app throughout the day.

See your stats

From the clock face, swipe up to see your daily stats, including:

- Steps taken
- Active minutes

Find your complete history and other information detected by your tracker in the Fitbit app.

Track your sleep

Wear Ace to bed to automatically track your time asleep and movement during the night to help you understand your sleep patterns. Sync your tracker when you wake up and check the Fitbit app to see your sleep stats, including when you go to bed, how long you're asleep, and how long you spend awake or restless.

For more information, see [the related help article](#).

Set a sleep goal

To start, you have a sleep goal of 9 hours of sleep per night. Customize this goal to meet your needs.

For more information, see [the related help article](#).

Track a daily activity goal

Ace tracks your progress toward a daily activity goal of your choice. When you reach your goal, your tracker vibrates and shows a celebration.

Choose a goal

To begin, your goal is to take 10,000 steps per day. Choose to change the number of steps, or pick a different activity goal depending on your device.

For more information, see [the related help article](#).

Track progress toward your goal on Ace. For more information, see "[See your stats](#)" on the previous page.

Track your hourly activity

Ace helps you stay active throughout the day by keeping track of when you're stationary and reminding you to move.

Reminders nudge you to walk at least 250 steps each hour. You feel a vibration and see a reminder on your screen at 10 minutes before the hour if you haven't walked 250 steps. When you meet the 250-step goal after receiving the reminder, you feel a second vibration and see a congratulatory message.

Turn on reminders to move in the Fitbit app.



For more information, see [the related help article](#).

Set an alarm

Ace can gently vibrate to wake or alert you with an alarm. Set and delete alarms in the Fitbit app. When the alarm goes off, double-tap the tracker to dismiss it.

For more information, see [the related help article](#).



Notifications from your phone

Ace can show call notifications from your phone to keep you informed. Keep your tracker within 30 feet of your phone to receive notifications.

Set up notifications

Check that Bluetooth on your phone is on and that your phone can receive notifications (often under Settings > Notifications). Then set up notifications:

1. From the Today tab  in the Fitbit app, tap your profile picture > Ace tile.
2. Tap **Notifications**.
3. Follow the on-screen instructions to pair your tracker if you haven't already.
Call notifications are turned on automatically.

For more information, see [the related help article](#).

See incoming notifications

When your phone and Ace are within range, a call causes the tracker to vibrate. If the screen is off, turn your wrist or double-tap Ace to wake it up.

The notification scrolls three times with the name or number of the caller. The notification is visible for one minute.



Note that notifications are shown horizontally, even if the clock orientation is normally vertical.

Change the clock face

The Fitbit Gallery offers a variety of clock faces to personalize your tracker.

1. From the Today tab  in the Fitbit app, tap your profile picture > Ace tile.
2. Tap **Gallery** > **Clocks** tab.
3. Browse the available clock faces. Tap a clock face to see a detailed view.
4. Tap **Install** to add the clock face to Ace.

Update Ace

Update your tracker to get the latest feature enhancements and product updates.

When an update is available, a notification appears in the Fitbit app. After you start the update, follow the progress bars on Ace and in the Fitbit app until the update is complete. Keep your tracker and phone close to each other during the update.

Updating Ace takes several minutes and may be demanding on the battery. We recommend plugging your tracker into the charger before starting the update.

For more information, see [the related help article](#).

Restart Ace

If you can't sync Ace, don't see your stats, or your tracker is unresponsive, restart your device:

1. Plug the charging cable into the USB port on a computer or a UL-certified USB wall charger.
2. Clip the other end of the charging cable to the port on the back of the tracker. The pins on the charging cable must lock securely with the port. You'll know the connection is secure when the tracker vibrates and you see a battery icon on your tracker's screen.
3. Press the button on the charging cable 3 times within 8 seconds, briefly pausing between presses. The button is on the end of the charging cable that is plugged into the computer. 8 seconds after the first button press, the Fitbit logo appears on the tracker's display. This indicates that Ace restarted.

Restarting your tracker doesn't delete any data.

General Info and Specifications

Sensors and Components

Materials

The band that comes with Ace is made of a flexible, durable elastomer material similar to that used in many sports watches.

The clasp and housing on Ace are made of surgical-grade stainless steel. While all stainless steel contains traces of nickel and can cause an allergic reaction in someone with nickel sensitivity, the amount of nickel in all Fitbit products meets the European Union's stringent Nickel Directive.

Wireless technology

Ace contains a Bluetooth 4.0 radio transceiver.

Haptic feedback

Ace contains a vibration motor for alarms, goals, notifications, and reminders.

Ace contains a rechargeable lithium-polymer battery.

Memory

Refer to the following table for information on how long Ace stores stats and data in between the times when it syncs.

Type of data	Days stored
Minute-by-minute stats	5
Sleep data	7
Summary totals	30

Display

Ace has an OLED display.

Band size

Band sizes are shown below. Note that accessory bands sold separately may vary slightly.

Extra small band	Fits a wrist between 5.0 and 6.1 inches (125 mm - 155 mm) in circumference
Large band	Fits a wrist up to 6.9 inches (177 mm) in circumference

Environmental conditions

Operating temperature	14° to 113° F (-10° to 45° C)
Non-operating temperature	-4° to 14° F (-20° to -10° C) 113° to 140°F (45° to 60° C)
Water Resistance	Showerproof. Do not swim with the device or submerge it in water. The device has an IPX7 rating and is water-resistant up to 1 meter.
Maximum operating altitude	30,000 feet (9,144 m)

Learn more

To learn more about your tracker, visit help.fitbit.com.

Return policy and warranty

Find warranty information and the fitbit.com return policy on [our website](#).

Regulatory and Safety Notices

Notice to the User: Regulatory content for certain regions can also be viewed on your device. To view the content:

Settings > About > Regulatory Info

USA: Federal Communications Commission (FCC) statement

FCC ID: XRAFB406

This device complies with Part 15 of the FCC Rules.

Operation is subject to the following two conditions:

1. This device may not cause harmful interference and
2. This device must accept any interference, including interference that may cause undesired operation of the device.

FCC Warning

Changes or modifications not expressly approved by the party responsible for compliance could void the user's authority to operate the equipment.

Note: This equipment has been tested and found to comply with the limits for a Class B digital device, pursuant to part 15 of the FCC Rules. These limits are designed to provide reasonable protection against harmful interference in a residential installation. This equipment generates, uses and can radiate radio frequency energy and, if not installed and used in accordance with the instructions, may cause harmful interference to radio communications. However, there is no guarantee that interference will not occur in a particular installation. If this equipment does cause harmful interference to radio or television reception, which can be determined by turning the equipment off and on, the user is encouraged to try to correct the interference by one or more of the following measures:

- Reorient or relocate the receiving antenna.
- Increase the separation between the equipment and receiver.
- Connect the equipment into an outlet on a circuit different from that to which the receiver is connected.
- Consult the dealer or an experienced radio/TV technician for help.

This device meets the FCC and IC requirements for RF exposure in public or uncontrolled environments.

Canada: Industry Canada (IC) statement

Model/Modèle FB406

IC: 8542A-FB406

This device meets the IC requirements for RF exposure in public or uncontrolled environments.

Cet appareil est conforme aux conditions de la IC en matière de RF dans des environnements publics ou incontrôlée

IC Notice to Users English/French in accordance with current issue of RSS GEN:

This device complies with Industry Canada license exempt RSS standard(s).

Operation is subject to the following two conditions:

1. this device may not cause interference, and
2. this device must accept any interference, including interference that may cause undesired operation of the device.

Cet appareil est conforme avec Industrie Canada RSS standard exempts de licence (s). Son utilisation est soumise à Les deux conditions suivantes:

1. cet appareil ne peut pas provoquer d'interférences et
2. cet appareil doit accepter Toute interférence, y compris les interférences qui peuvent causer un mauvais fonctionnement du dispositif

European Union (EU)

Models FB406 and FB406

Frequency Bands and Power

Data given here is the maximum radio-frequency power transmitted in the frequency band(s) in which the radio equipment operates.

Simplified EU Declaration of Conformity

Hereby, Fitbit LLC declares that the radio equipment type Model FB406 is in compliance with Directive 2014/53/EU. The full text of the EU declaration of conformity is available at the following internet address: www.fitbit.com/safety

Vereinfachte EU-Konformitätserklärung

Fitbit LLC erklärt hiermit, dass die Funkgerätypen Modell FB406 die Richtlinie 2014/53/EU erfüllen. Der vollständige Wortlaut der EU-Konformitätserklärungen kann unter folgender Internetadresse abgerufen werden: www.fitbit.com/safety

Declaración UE de Conformidad simplificada

Por la presente, Fitbit LLC declara que el tipo de dispositivo de radio Modelo FB406 cumple con la Directiva 2014/53/UE. El texto completo de la declaración de conformidad de la UE está disponible en la siguiente dirección de Internet: www.fitbit.com/safety

Déclaration UE de conformité simplifiée

Fitbit LLC déclare par la présente que les modèles d'appareils radio FB406 sont conformes à la Directive 2014/53/UE. Les déclarations UE de conformité sont disponibles dans leur intégralité sur le site suivant : www.fitbit.com/safety

Dichiarazione di conformità UE semplificata

Fitbit LLC dichiara che il tipo di apparecchiatura radio Modello FB406 è conforme alla Direttiva 2014/53/UE. Il testo completo della dichiarazione di conformità UE è disponibile al seguente indirizzo Internet: www.fitbit.com/safety



Safety Statement

This equipment has been tested to comply with safety certification in accordance with the specifications of EN Standard: EN60950-1:2006 + A11:2009 + A1:2010 + A12:2011 + A2:2013 & EN62368-1:2014 + A11:2017.

Australia and New Zealand



R-NZ

China



部件名称	有毒和危险品					
	铅 (Pb)	水银 (Hg)	镉 (Cd)	六价铬 (Cr(VI))	多溴化苯 (PBB)	多溴化二苯 醚 (PBDE)
Ace Model FB406						
表带和表扣	○	○	○	○	○	○
电子	X	○	○	○	○	○

本表格依据 SJ/T 11364 的规定编制

○ = 表示该有害物质在该部件所有均质材料中的含量均在 GB/T 26572规定的限量要求以下

X = 表示该有害物质至少在该部件的某一均质材料中的含量超出 GB/T 26572规定的限量要求

Mexico



IFETEL: RCPFIFB15-2258

Japan



Philippines

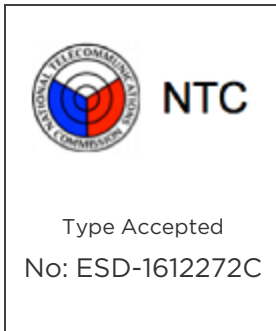

Singapore

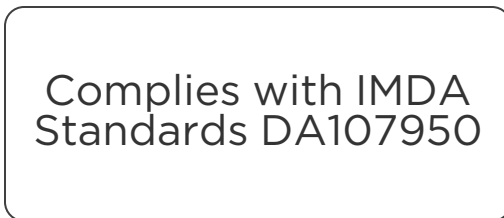

South Africa

Model FB406



TA-2015/2353

South Korea

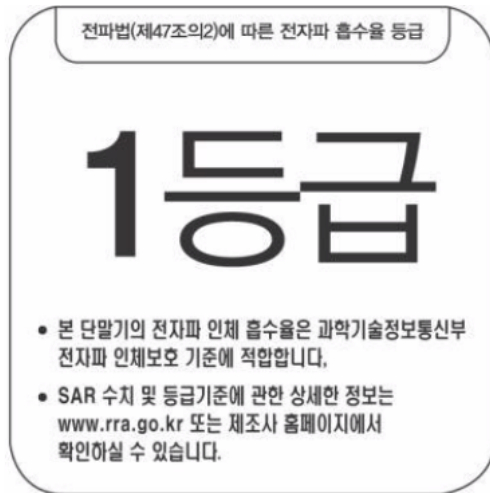

클래스 B 장치(가정 사용을 위한 방송 통신 기기): EMC 등록 주로 가정용 (B 급)으로하고, 모든 지역에서 사용할 수 있습니다 얻을이 장치.

*** 해당 무선설비는 전파혼신 가능성이 있으므로 인명안전과 관련된 서비스는 할 수 없습니다.***



- 사용 주파수 (Used frequency): 2402 MHz-2480 MHz
- 채널수 (The number of channels): 40
- 공중선전계강도 (Antenna power): -7.4dBi
- 변조방식 (Type of the modulation): GFSK
- RF 출력(RF Output): 3.6dBm
- 안테나 유형(Antenna Type): Monopole Antenna (Stamped metal)
- 작동 온도 범위(Operating Temperature Range): -10C ~ 50C
- 동작 전압 (Operating voltage): DC 3.7V

KC 인증서 정보 KC Certificate Information

- 1) 장비 이름 Equipment name: 저전력 무선 장치 (무선 데이터 통신의 무선 장치)
Low power radio equipment (wireless devices of wireless data communications)
- 2) 모델 이름 Model name: FB406
- 3) 인증서 번호 Certificate number : MSIP-CMM-XRA-FB406
- 4) 회사 이름 Company Name : Fitbit, Inc.
- 제조업 자 Manufacturer: Fitbit, Inc. / 중국(China)
- 6) 제조 일자 Manufactured Date: 201_

Taiwan



CCAJ15LP6230T1

注意!

依據 低功率電波輻射性電機管理辦法

第十二條 經型式認證合格之低功率射頻電機，非經許可，公司、商號或使用者均不得擅自變更頻率、加大功率或變更原設計之特性及功能

第十四條

低功率射頻電機之使用不得影響飛航安全及干擾合法通信；經發現有干擾現象時，應立即停用，並改善至無干擾時方得繼續使用。

前項合法通信，指依電信法規定作業之無線電通信。

低功率射頻電機須忍受合法通信或工業、科學及醫療用電波輻射性電機設備之干擾。

Translation:

Low power warning:

According to the management method of low power radio wave radiating motor.

Article 12

Without permission, any company, firm or user shall not alter the frequency, increase the power, or change the characteristics and functions of the original design of the certified lower power frequency electric machinery.

Article 14

The application of low power frequency electric machineries shall not affect the navigation safety nor interfere a legal communication, if an interference is found, the service will be suspended until improvement is made and the interference no longer exists. The foregoing legal communication refers to the wireless telecommunication operated according to the telecommunications laws and regulations. The low power frequency electric machinery should be able to tolerate the interference of the electric wave radiation electric machineries and equipment for legal communications or industrial and scientific applications.

United Arab Emirates

TRA Registered No: ER442211/16

Dealer No.: DA35294/14

©2022 Fitbit LLC. All rights reserved. Fitbit and the Fitbit logo are trademarks or registered trademarks of Fitbit in the US and other countries. A more complete list of Fitbit trademarks can be found at the [Fitbit Trademark List](#). Third-party trademarks mentioned are the property of their respective

Index

S

Specifications 18