

**GEARMORE INC.**

# FLAIL MOWERS

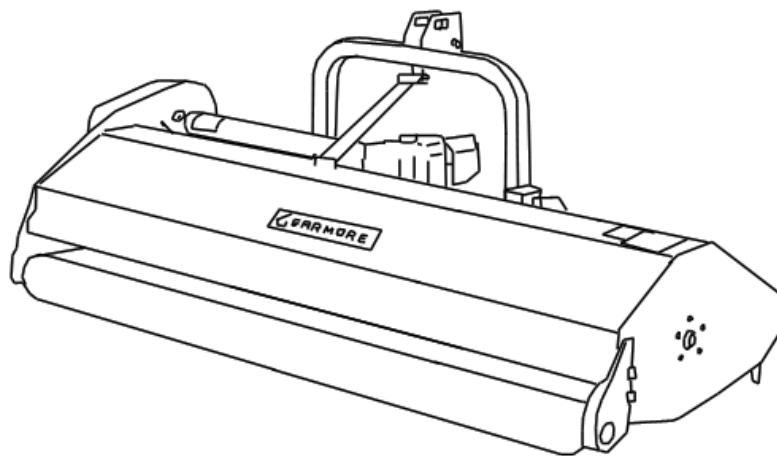

**Operation, Service,  
& Parts Manual For  
SLE-120, SLE-160,  
& SLE-190 Models**

May 2008

# TABLE OF CONTENTS

	<b>PAGE</b>
General Information .....	1
Introduction.....	1
Symbols .....	1
Safety Labels .....	2 - 3
Technical Features.....	4
Terminology.....	5
Main Parts Terminology .....	5
Identification Plate.....	5
Safety .....	6
Allowed Use.....	6
Improper Use .....	6
Safety in the Workplace.....	6
Operator's Requirements .....	6
General Safety Rules.....	7 - 8
Set-Up .....	9
Attachment to the Tractor.....	9 - 10
Driveline Attachment.....	11
Top Mast Adjustment .....	12
Side Skids (Optional).....	13
Blades.....	13
Starting Up.....	13
Transport & Storage .....	14
Maintenance .....	15 - 16
Belt Drive .....	17
Cutting Shaft.....	18
Torque Specifications .....	18
Parts .....	19-23
Flail Mower Parts .....	19-22
Driveline .....	23
Limited Warranty .....	24

# GENERAL INFORMATION

## INTRODUCTION:

The SLE Flails are primarily designed to mow grass, weeds and light brush.

The mowers are assembled for operation with 540 RPM tractor input only (rated PTO up to 45 HP), and supplied standard with Cat. I lift pins for tractor attachment.

The mowers can fit Cat. I quick attach hitch, by using suitable bushings to adapt diameters of lift pins.

## SYMBOLS:

This booklet contains three "safety graphic symbols" which highlight the relevant danger levels or important information:



**It draws the operator's attention to situations which can jeopardize people's safety.**

---



**It draws the attention to situations which jeopardize the machine efficiency but not people's safety.**

---



**It highlights general information which does not endanger people's safety or the efficiency of the parts.**

---

# SAFETY LABELS

## SAFETY LABELS:

The safety labels and the information on the machine, listed in the following table, must be necessarily read and respected; failure to follow these warnings can cause death or severe injuries. Make sure that the labels are always present and legible, should this not be the case, contact your nearest Gearmore dealer to replace the missing or illegible ones.

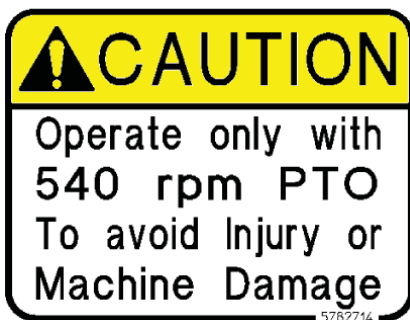
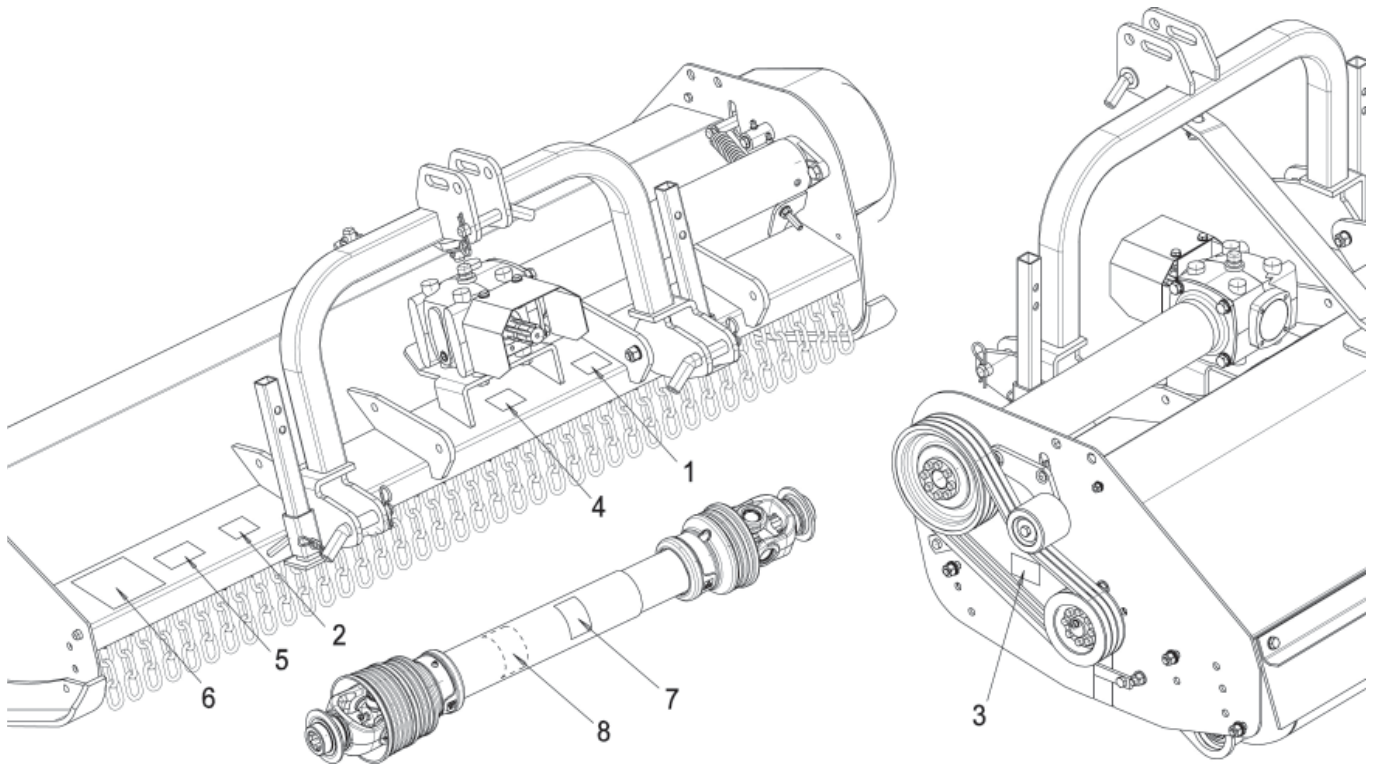

# SAFETY LABELS



5

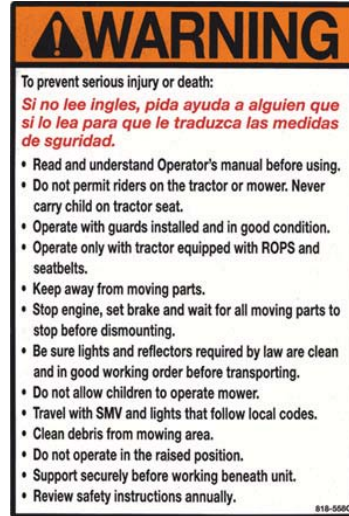

6



7



8

## OTHER LABELS:



# TECHNICAL FEATURES

MODEL		SLE-120	SLE-160	SLE-190
Working Width:	mm	1184	1584	1884
	inch	47"	63"	75"
Overall Dimensions (L x W x H)		1300x980x760	1700x980x760	2000x980x760
Rated PTO Power:	hp	20 - 45	30 - 45	35 - 45
Weight:	kg	220	264	300
	lbs.	485	582	660
Number of Knives:				
"Y" Blades:		44	60	72
"Ducksfoot" Blades:		22	30	36
Hitch:		3-Point, Cat. I	3-Point, Cat. I	3-Point, Cat. 1
Rotor Diameter:	mm	114	114	114
Rotor Tube Thickness:	mm	8	8	8
Swing Diameter:	mm	370	370	370
Rotor Speed:	rpm	2356	2356	2356
Knives Tip Speed (@540 rpm):	m/s	45.6	45.6	45.6
	fpm	8984	8984	8984
Rear Roller Diameter:	mm	140	140	140
Working Height (Adjustable by the roller):	inch	1 ¼" - 3 ½"	1 ¼" - 3 ½"	1 ¼" - 3 ½"
<b>OTHER FEATURES</b>				
3-Point Hitch	Cat. I Quick Hitch Compatible			
Input Speed				
Side Slicing Blades (no tools blade changing)				
Mounting	Center or Offset			
<b>SERIAL EQUIPMENT</b>				
Driveline	Eurocardan Series 5 (Cat. ASAE 4R)			
Gearbox	Bevel Spiral Gears with Free Wheel (Ratio 2.73:1)			
Transmission	Side Belt Transmission with Spring Idler			
Belts	#3 Narrow SPA Section V-Belt			
Double Parking Stand				
<b>OPTIONS</b>				
Side Skids				
Side Protections				

# MAIN PARTS TERMINOLOGY

## MAIN PARTS TERMINOLOGY:

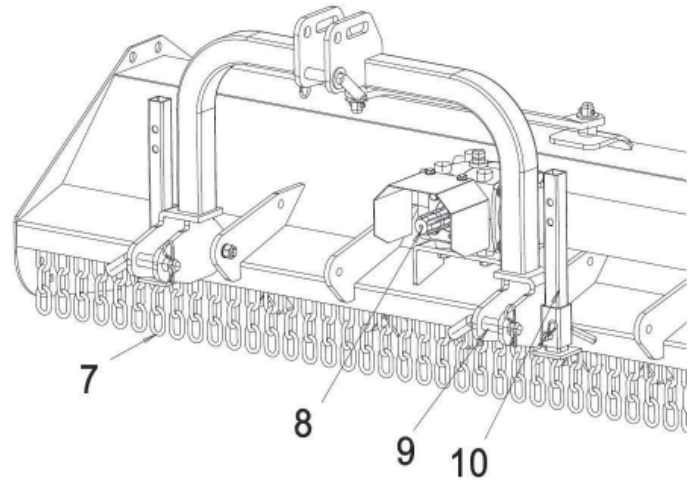
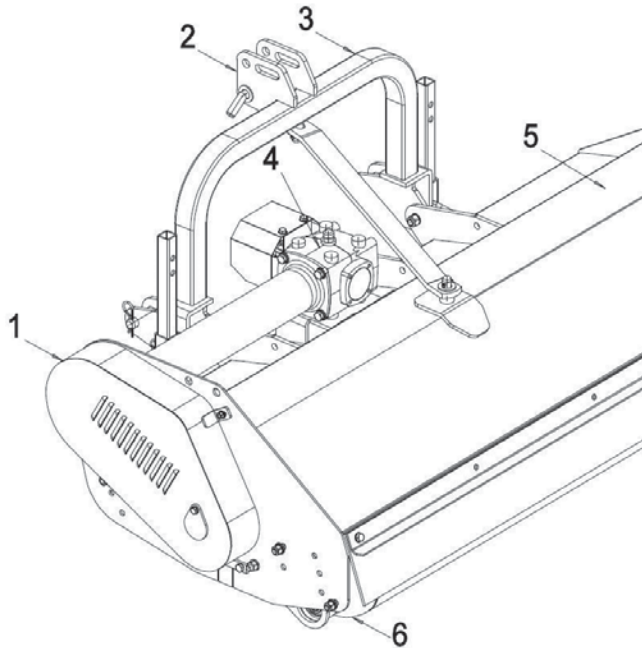

- |                 |                  |
|-----------------|------------------|
| 1. Belt Cover   | 6. Rear Roller   |
| 2. Upper Hitch  | 7. Safety Chains |
| 3. 3-point Mast | 8. Input Shaft   |
| 4. Gearbox      | 9. Lower Hitch   |
| 5. Frame        | 10. Stand Leg    |

## IDENTIFICATION PLATE

An identification plate is placed on every flail mower:



**When asking for information or technical service,  
always specify the machine type and width.**

# SAFETY

## ALLOWED USE:

SLE flail mowers, as described in this instruction and maintenance booklet, have been specifically designed to mow grass, weeds, and light brush up to 1" diameter. Any other use jeopardizes the operator's safety and the machine integrity.

## IMPROPER USE:

The mower was designed to mow grass, weeds, and light brush only. Only operate this mower on a properly sized and equipped tractor.

When using SLE flail mowers, it is particularly **forbidden**:

- The attachment to tractors of unsuitable power or weight.
- To use other than 540 R.P.M. PTO speed.
- To work in excessively stony grounds.
- To work on excessive slopes.
- To lift the machine when the power take off is engages.
- To approach the machine when wearing inappropriate work clothing.
- To get on the machine while it is being used or transported.



**Operating this mower in an application for which it is not designed and/or operating with the wrong size tractor can cause mower component damage and equipment failure resulting in possible serious injury or death.**

## SAFETY

### SAFETY IN THE WORKPLACE:

Most of the accidents which take place while the operator is using the machine or the equipment or during their maintenance or repair are caused by a lack of compliance with the basic safety precautions. It is necessary, therefore, to become more and more conscious of the potential risks of one's action by constantly paying attention to its effects.

**If potentially dangerous situations are known, accidents can be prevented!**

### OPERATOR'S REQUIREMENTS:

All operators using the equipment must be competent and meet necessarily the following features:

**Physical:** good eyesight, coordination and capability of carrying out all functions required for the machine's use.



# SAFETY

**Mental:** Capability of understanding and applying the established rules and safety precautions. Users must pay attention and be sensible for their own and other people's safety.

**Training:** users must have read and studied this manual, its eventual enclosed graphs and schemes and its identification and danger plates. They must be skilled and trained on any use or maintenance activities.

## WORK CLOTHING:

When working and especially when executing repair or maintenance activities, it is necessary to wear the following clothing and safety accessories:

- Overalls or other comfortable clothing, not too loose to prevent the possibility that parts of them might be caught in the moving parts.
- Protective gloves for hands.
- Protective glasses or faceplate to protect eyes and face.
- Protective helmet for the head.
- Safety shoes



**Wear only personal safety accessories in good condition and complying with the rules in force.**

## GENERAL SAFETY RULES

### ALWAYS CONSIDER THE FEATURES OF THE AREA WHERE WORK IS TAKING PLACE:

- When the equipment is running, it is forbidden to stand within the field of action of the shredder or of the other accessories of which it is provided with.

### PREPARE THE WORK:

- Before and when working, do not drink alcohol, take drugs, or any other substances which may alter your capability of working with machine tools.
- Be sure to have sufficient fuel, to prevent a forced stopping of the machine, maybe during a critical movement.
- Do not use the equipment under unsafe conditions. For instance, it is forbidden to execute makeshift repair activities just to start working; it is forbidden to work at night with an insufficiently illuminated working area.

# SAFETY

- NEVER operate implement without all shields in place and in good operational condition. The operator must be familiar with the mower and tractor and all associated safety practices before operating the mower and tractor.

## **WHEN WORKING OR DURING THE MAINTENANCE ACTIVITIES IT IS NECESSARY TO REMEMBER:**

- The labels and stickers providing instructions and pointing out the dangers, must not be removed, hidden, or made illegible.
- Do not remove, except in case of maintenance, the shields, guards, and deflectors equipped on the mower. When it is necessary to remove them, stop engine, handle with care and reassemble them properly before restarting the engine and using the equipment. The mower is equipped with protective deflectors to prevent objects being thrown from the mower by the blades, however, no shielding is 100% effective. All shields, guards, and deflectors equipped on the mower must be maintained in good operational condition.
- It is forbidden to lubricate, clean and adjust the moving parts while they are running.
- During maintenance or adjustment activities on the equipment it is forbidden to use hands for executing operations for which there are specific tools.
- Do not use tools in bad condition or inappropriately, for instance pliers rather than monkey spanners, etc.
- When maintenance or repairs are completed check out that no tools, wiping rags, or other materials are left inside spaces or guides with moving parts.
- While using the equipment, it is forbidden to make more than one person give directions and make signals. The eventual directions and signals relating to the load handling must be given by one person only.
- Do not unexpectedly call an operator while he is working if not necessary; it is forbidden as well to frighten or throw objects at the operator, even if just for fun.
- Watch out for those who are present, especially the children!
- Do not make people get on the machine.
- When the equipment is not needed, stop the vehicle's engine, park it on flat ground with first speed and parking brake on, with the machine rested on the ground and PTO disengaged.
- Do not clean, lubricate, repair or adjust with the engine running and the machine lifted.
- Never use the machine on steep slopes which may jeopardize the equipment's stability.

**The manufacturer declines all responsibility for a lack of compliance with these instructions.**

# SET UP

## ATTACHMENT TO THE TRACTOR

Before operating the mower, carefully read this Operator's Manual, completely understand the safety instructions, and know how to operate correctly both the tractor and the PTO shaft, reading carefully the instruction manuals of the tractor and PTO shaft manufacturers.

All SLE flail mowers have been manufactured to be attached to any tractor provided with hydraulic and universal 3-point hitch.

The tractor used to operate the mower must have the power, capacity, and required equipment to safely operate the mower. Operating the mower on improperly sized and equipped tractors may cause tractor and/or mower damage and could be a potential danger to the operator and passers-by.

Before attaching the equipment to the tractor, set both on a flat and smooth ground and make sure that nobody is standing between them.

Move slowly the tractor towards the flail mower by aligning the tractor hydraulic lift arms to the two mower hitches' lateral brackets; stop engine and set parking brake.

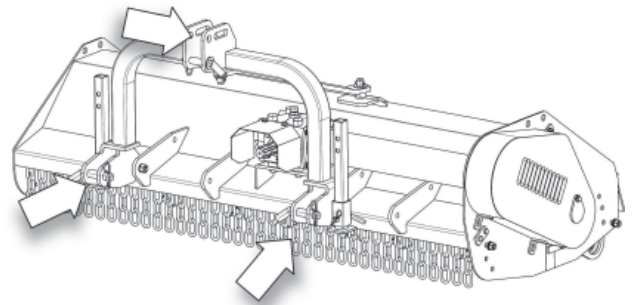
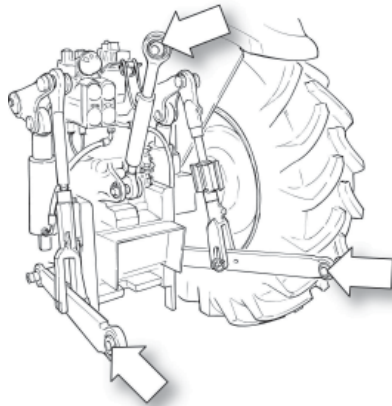

Connect first the lower arms by removing the release pins of the brackets placed on the plates, inserting the lift arms into the arms center and fastening them with the relevant release pins, which had been removed.

Connect, then, the tractor top link to the third upper point by removing the pin located between the plates, inserting the top link itself and locking it with the pin.

## DIMENSIONS OF MOWER HITCH:

### CAT I Traditional Hitch Specification -

Width from outside to outside A-frame .....	26 $\frac{7}{8}$ "
Height from bottom hitch pin to top pin .....	18"
Lower pin diameter .....	$\frac{7}{8}$ "
Upper pin diameter .....	$\frac{3}{4}$ "

### CAT I Quick Hitch Specifications -

Width from outside to outside A-frame .....	26 $\frac{7}{8}$ "
Height from bottom hitch pin to top pin .....	15"

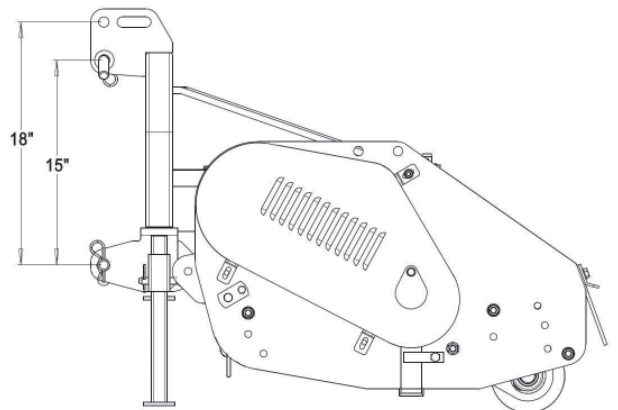

## SET UP

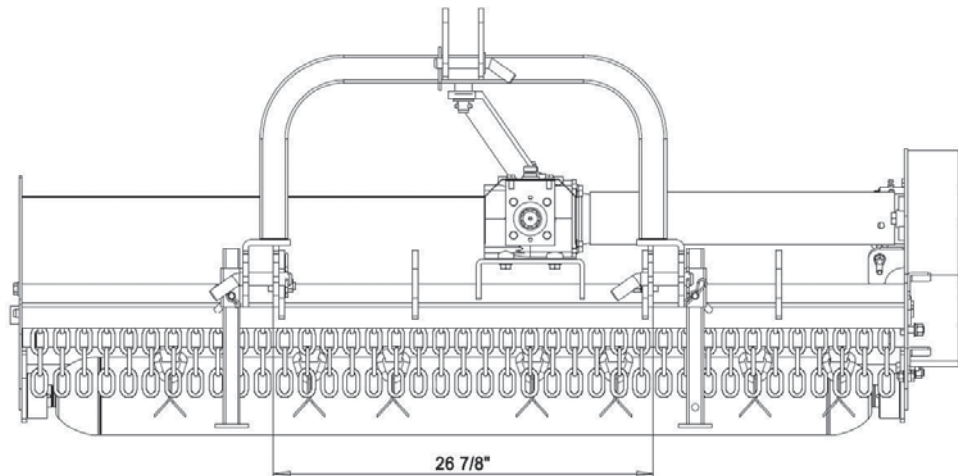

Adjust the third point so that the upper part of the frame is parallel to the ground. Lock all connection parts with the special sway chains or tie rods.

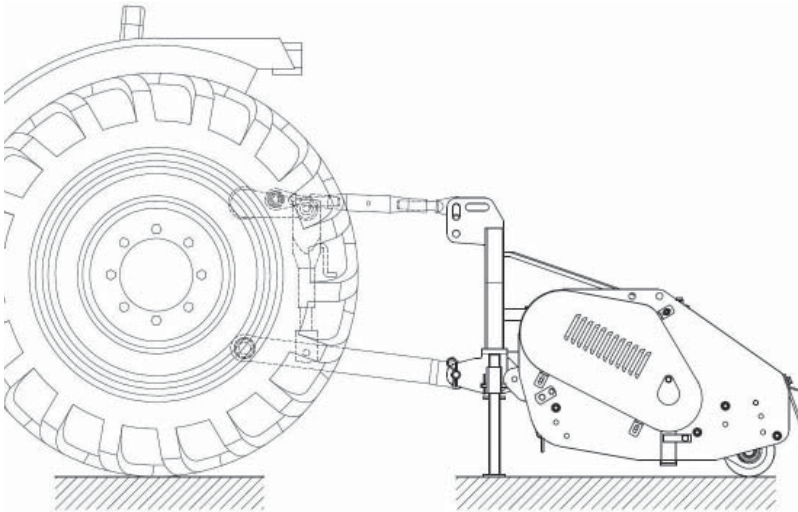

It is always good to make sure that the central gearbox axis is parallel to the ground thus reducing the stresses on the power takeoff and extending the working life of the equipment.

---

### **Danger**

Pay attention to the tractor's front wheels grip when the equipment is set up and lifted; if the wheels appear to be too lightened, ballast the tractor front tires or add front weights.

---

### **Caution**

After executing the above-mentioned activities it is always good to check that all bolts and nuts of your shredder are tightened strongly (refer to the torque specifications in this manual).

---

# SET UP

## DRIVELINE ATTACHMENT

Before assembling the PTO shaft, check out that its RPM and direction of rotation match those of the tractor. Moreover, read carefully the instruction manuals of the PTO shaft and the tractor manufacturers. Before starting work, make sure all safety shields are in place. Check in particular that the safety guards cover the PTO shaft throughout its extension. When attaching the mower input driveline to the tractor PTO, be sure that the connecting yoke spring activated locking collar slides freely and the locking balls are seated securely in the groove on the tractor PTO shaft. A driveline not attached correctly to the tractor PTO shaft could come loose and result in personal injury and damage to the implement.



**Caution**

**Make sure the driveline will not bottom out (at its most compressed position there must be at least a 3/4" clearance between each profile end and opposite profile universal joint) or become disengaged (at its farthest extended position a minimum profile engagement of 1/3 of the length must be maintained).**

Check out that the cardan shaft minimum and maximum length are the ones required by the machine-tractor coupling. Should problems arise, contact a skilled repair shop or the driveshaft retailer. After installation, secure safety guards both to the tractor and the machine using the special chains and make sure that they pivot freely. If the PTO shaft is equipped with other safety devices, such as a pair limiter or freewheels, be sure to install them on the machine side. As for the PTO use and maintenance refer to the relevant booklet.

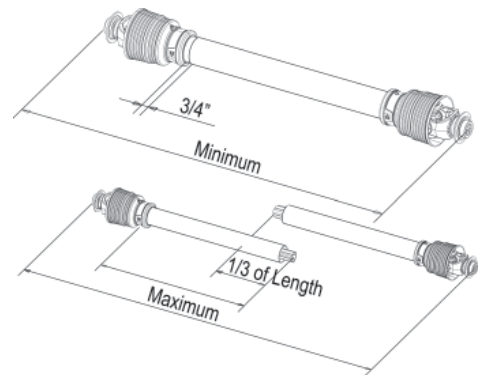

## WORKING HEIGHT ADJUSTMENT

The machine's working height is determined by the position of the rear roller. Lifting the roller the cutters get close to the soil, whereas lowering it the cutters get far from it. After a modification of the working height be sure that the cutters skim the ground; a direct contact with it would cause their wear and this could affect the cutting rotor balance and may cause objects to be thrown out from under the mower deck.

To adjust the roller height:

- Screw out and remove screws **B** which fasten the roller on both sides.
- Loosen screw **A**.
- Lift or lower roller through holes **C**.
- Insert back and tighten screws **B**.
- Tighten screw **A**.

# SET UP

## TOP MAST ADJUSTMENT

SLE flail's top mast can be set in two different positions (central and offset). To change position:

- Screw out and extract screws/nuts **A**.
- Disassemble frame **B** and place it on the flail's frame through holes **C**.
- After adjustment insert screws/nuts **A** back and tighten strongly.

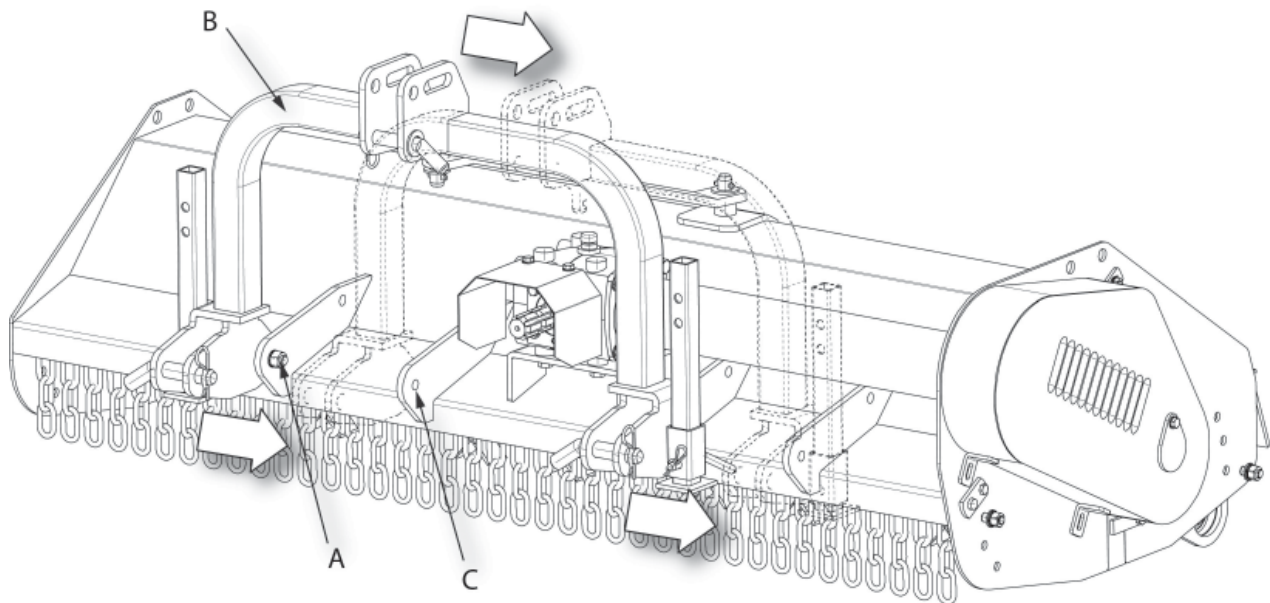
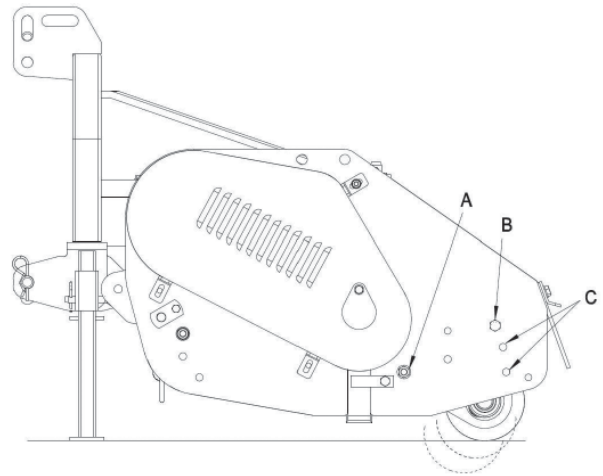

 **Danger**

Work height and top mast adjustments must be made only on working ground and only after having stopped the engine, disengaged the power takeoff and set the parking brake. If necessary, lift the machine from the ground but, in order to avoid risks for people, place it on rests thus preventing any injuries that might be caused by its sudden fall.

# SET UP

## SIDE SKIDS (OPTIONAL)

SLE flail mowers may be optionally equipped with side skids, having the function of avoiding an excessive sinking of the machine on the ground during working.

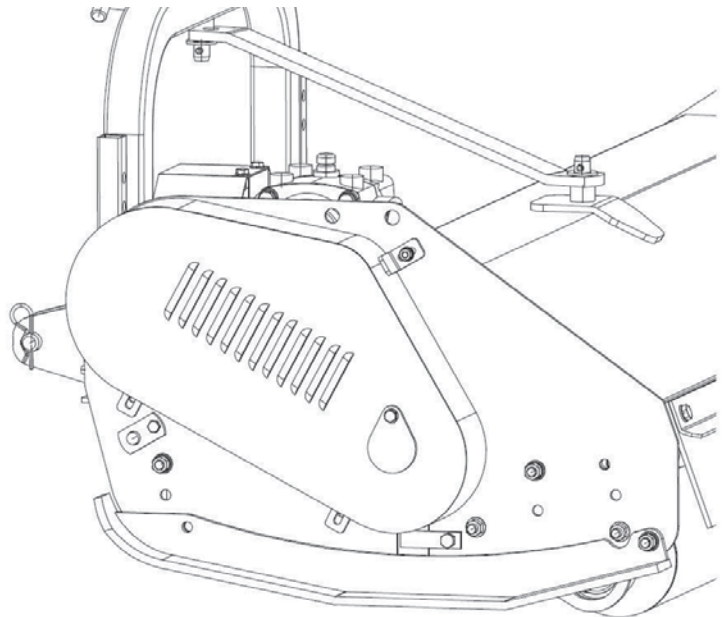

## BLADES

Shredders can be equipped with two different types of blades according to the work to be done:



**"Y" BLADES**

Knife for grass coarse cut and light brush shredding



**"DUCKSFOOT" BLADES**

Grass blade for finish cut

## STARTING UP

When all setting up operations are completed, your machine is ready to be used; after reaching the work place, make certain that the area is clear of bystanders and passersby, and drop the machine down just a few feet over the working position. At this point it is possible to engage power take off, drop the machine down to work position and start using it.



**Danger**

**NEVER engage the PTO with the implement in the raised position.**

# TRANSPORT & STORAGE

## WORKING SPEED

The working speed depends on quality, diameter and height of the material to be cut; anyway, for efficient mower performance it must be between 2 and 5 MPH. The power takeoff speed must be 540 RPM maximum. Operate the mower at its full rated PTO speed to maintain blade speed for a clean cut.



**Do not exceed the rated PTO speed for the implement. Excessive PTO speeds can cause driveline or blade failures resulting in serious injury or death.**

## ROAD TRANSPORT

Extreme caution should be used when transporting the tractor and implement on public roadways. The tractor must be equipped with all required safety warning features including a SMV emblem and flashing warning lights which are clearly visible from the rear of the unit. Make sure you are in compliance with all local regulations regarding transporting equipment on public roads and highways. Do not exceed 20 MPH (32 kph). Reduce speed on rough roads and surfaces. Always use hazard flashers on the tractor when transporting unless prohibited by law.

## STORAGE

If your shredder will not be used for a long period of time, respect the following suggestions:

1. Wash the machine thoroughly and dry it.
2. Lubricate all bearings with enough grease to eliminate any cavities where water condensation may occur and cause damage. Refer to "Maintenance of the Machine" for location of all grease fittings. Be sure the vent on top of the gearbox is open.
3. Loosen the set nut and spindle jack to relieve drive belt tension (NOTE: Before next season's use, be sure to adjust the drive belt tension.)
4. Coat all exposed surfaces inside the mower with oil or grease to prevent rusting and pitting during storage.
5. Protect the whole machine with a tarpaulin and put it in a dry place.

## PRE-SEASON CHECK

1. Check the oil level in the gearbox and lubricate all bearings. See "Lubrication".
2. Adjust drive belt tension. See "Belt Drive".
3. Check out all equipment and replace damaged or worn parts.
4. Tighten all bolts and nuts (See "Torque Specifications").
5. Inspect for missing and/or broken blades/knives. Replace as necessary. See "Knife Replacement".
6. Be sure that the safety guards are in place and secure.
7. Run the Flail Mower at a low RPM checking to make sure that all driveline parts are moving freely.



# MAINTENANCE

## MAINTENANCE

Maintenance is a fundamental operation to extend life and performances of any agricultural vehicle; taking care of the machine grants you not only a good work execution, but also a longer life of the whole equipment and a greater safety on the workplace.

The operating times indicated in this manual have just an informative character and are referred to normal conditions of use; they can thus undergo variations according to the type of service.



- **Before injecting lubricating grease into the zerks, clean them accurately to prevent mud, dust, or other foreign matters from mixing up with grease, thus diminishing the lubrication effect.**
- **When adding or changing oil, it is better to use the same oil type, in order to avoid mixing oils with different features.**
- **Before executing maintenance activities on the machine, stop engine, disengage power takeoff, set parking brake and place the equipment on the ground in horizontal position.**
- **After the first working hours, check that all bolts and nuts are tightened; remember also to check often all the machine safety guards.**

### FIRST CHECK

- Check the correct tension of the driving belt
- Check that all bolts and nuts are tightened
- After the first 50 hours of work, change oil in the gearbox

### EVERY 8 HOURS OF WORK

- Rotate teardrop shaped plate B and grease the shaft support (driveline side) through the lubricating nipple A (picture 1)
- Grease the shaft support (external side) through the lubricating zerk A (picture 2)
- Grease the shaft support (driveline) and the belt tensioner idler pin through the lubricating zerks A and B (picture 3)
- Grease the stabilizing roller through the lubricating zerkA (picture 4)

### EVERY 50 HOURS OF WORK

- Check the correct tension of the driving belt
- Check that all bolts and nuts are tightened
- Check the cutters/hammers for wear
- Check the overgear unit oil level through plug A (picture 5)

### EVERY 500 HOURS OF WORK

- Check that all bolts and nuts are tightened
- Change oil in the overgear unit

### EVERY 1000 HOURS OF WORK

- Replace the driving belt

# MAINTENANCE

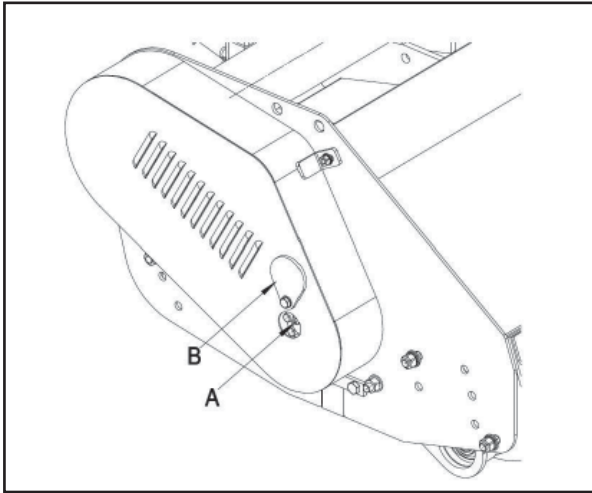

Picture 1

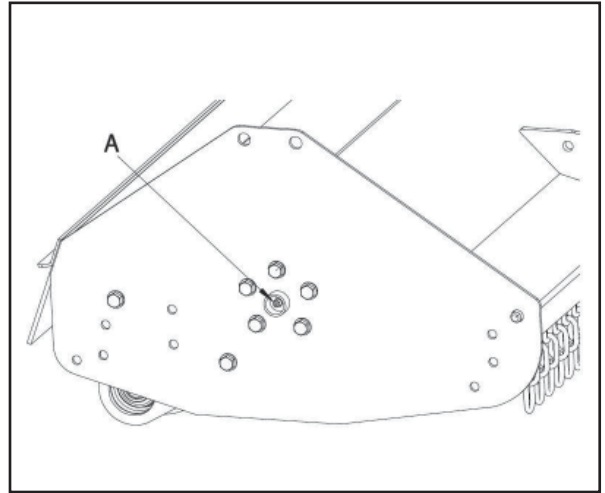

Picture 2

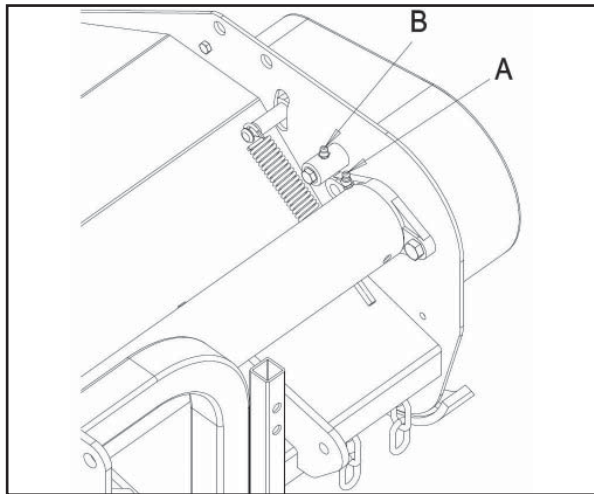

Picture 3

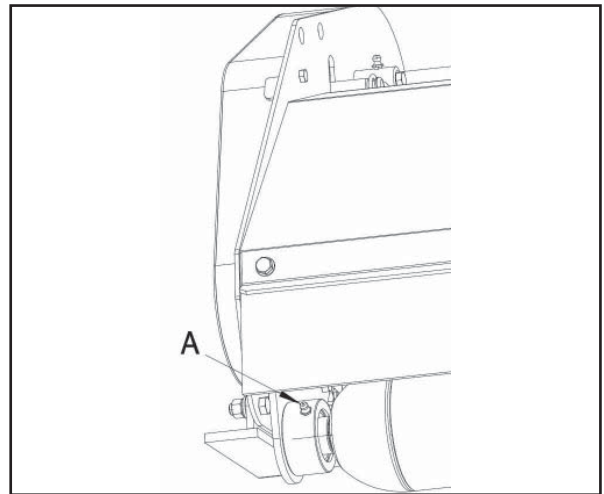

Picture 4

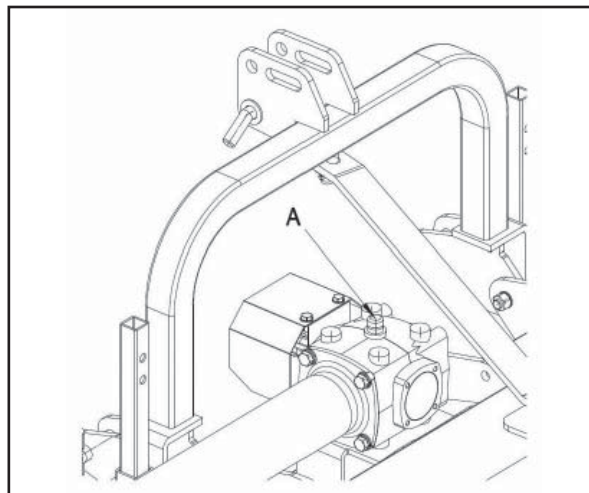

Picture 5

# MAINTENANCE

## ⚠ Caution

Get rid of exhaust oil in compliance with the relevant rules of the area where you operate. It is thus forbidden to pour it on the ground.

## BELT DRIVE

Rotor shaft is driven by a 3 belt transmission with automatic belt tensioner. To adjust belt tension screw or unscrew the bolt B to change the spring's tension.

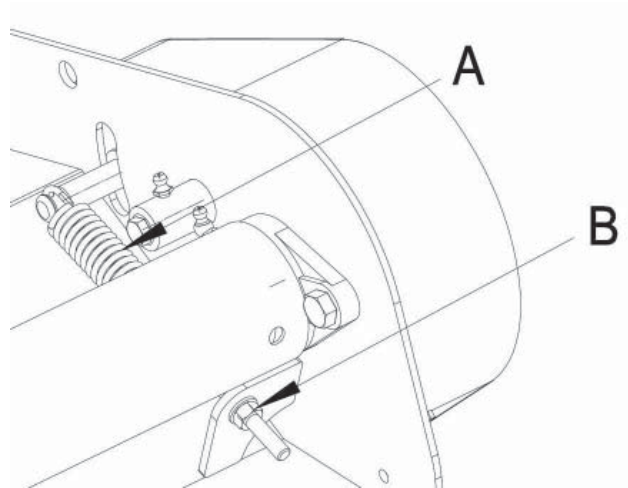

## ⚠ Danger

Make sure tractor engine is shut off, ignition key removed and all mower rotation has stopped before attempting to remove mower belt guard.

At correct tension, belt should have approximately  $\frac{3}{8}$ " deflection, at center of span, when a force of 40 lbs. is applied across entire width of band. Correctly tensioned spring will maintain proper belt adjustment.

Pulleys are locked to shaft by tapering hub bushing. Tightening torque for the screws (M8 threaded, grade 10.9) of tapering bushing is 30 lb/ft (as shown in Torque Specifications).

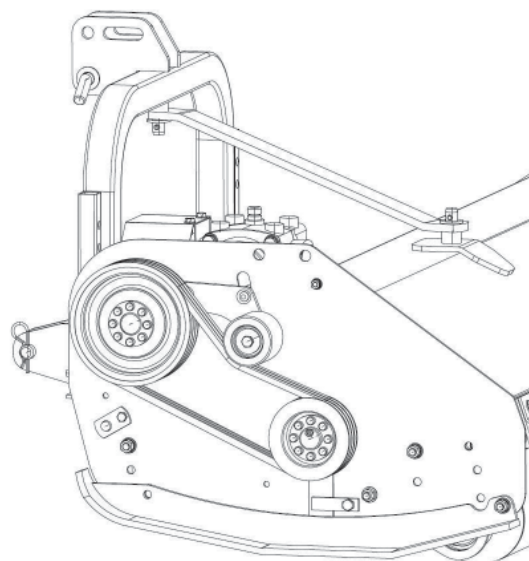

# MAINTENANCE

## CUTTING SHAFT

Cutting shaft is dynamically balanced. Welding on cutting shaft, heating, or lifting machine by shaft will adversely affect the cutting shaft balance. An out of balance shaft will vibrate excessively and result in premature machine failure. To assure a perfect functioning of the machine, check often (at least every 50 hours of work) that the shredder's blades are in good condition; in case they are broken, replace them with new spare parts. For any cutter replacement please contact the nearest Gearmore authorized dealer. Missing blades will cause the cutting shaft to go out of balance, resulting in excessive vibration and premature component failure.

To replace blades on mower fitted with "Quick Change" hangers, rotate D Ring and knife about 30 degrees (picture 6); then rotate D Ring and knife 90 degrees as shown in Picture 7. Finally slide off hanger (picture 8). Remove knife from D Ring and replace. Reverse procedure for installation.



**Danger**

**Before starting the inspection of blades, stop engine, set parking brake, and disengage power takeoff; lift the shredder with the tractor 3-point and place it on rests to avoid an accidental fall.**

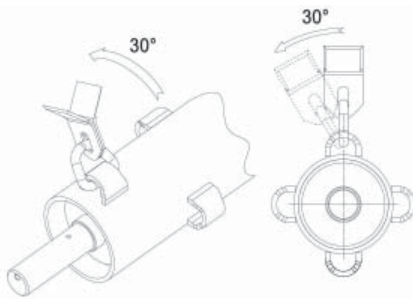

Picture 6

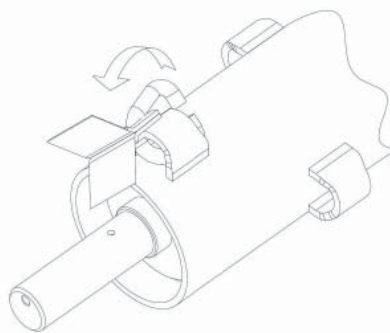

Picture 7

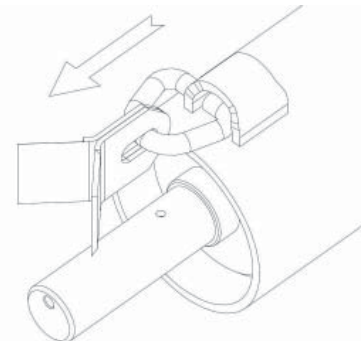

Picture 8

## TORQUE SPECIFICATIONS

For correct hardware tightening on the mower, we suggest the use of a suitable torque wrench and the applicable torque as listed in the table.

M-THREADED SCREW / BOLTS				
Bolt Grade				
Thread	8.8		10.9	
	Nm	lb / ft	Nm	lb / ft
M6	11	8.5	17	12
M8	28	20	40	30
M10	55	40	80	60
M12	95	70	140	105
M14	150	110	225	165
M16	240	175	305	225
M18	330	250	475	350

# PARTS BREAKDOWN

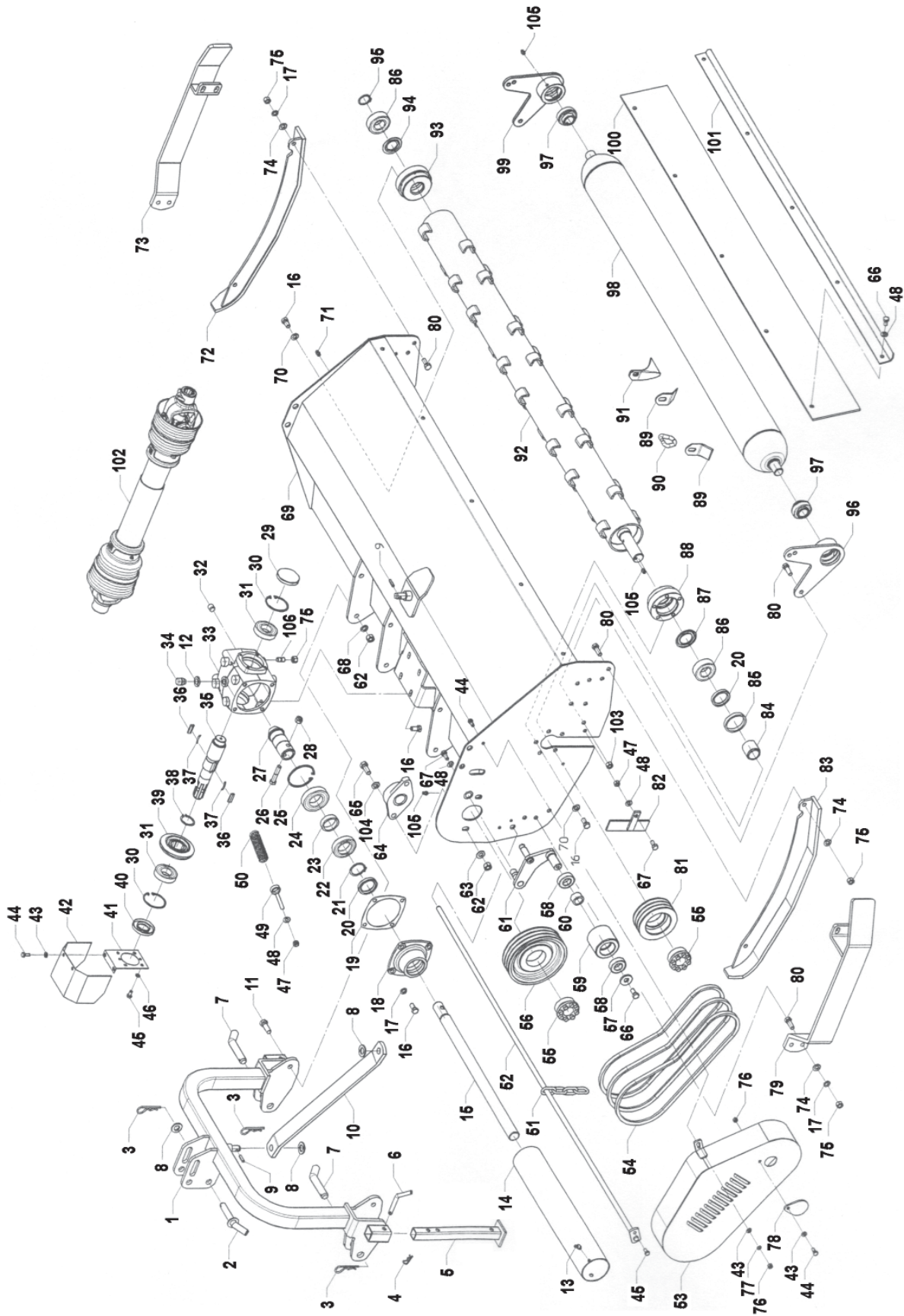

# PARTS LIST

<u>REF.</u>	<u>QTY.</u>	<u>PART NO.</u>	<u>DESCRIPTION</u>
1	1	5006758	3-Point Hitch
2	1	5005199	Upper Hitch Pin
3	3	6351004	Cotter Pin $\phi$ 4
4	2	6351003	Cotter Pin $\phi$ 3
5	2	5006768	Stand Leg
6	2	4236115	Stand Leg Pin
7	2	4301590	Lower Hitch Pin
8	3	34120020	Washer M20 UNI 6592
9	2	6330832	Pin UNI 6873 8 x 32
10	1	5836703	Rod
11	2	30214040	Screw M14 x 40 UNI 5739
12	1	6470117	Washer (Al/Cu) M18
13	1	6562008	Grease Nipple M8 UNI 7663-B 45°
14	1	5786705	Shaft Cover - SLE-120
14	1	5786707	Shaft Cover - SLE-160
14	1	5786708	Shaft Cover - SLE-190
15	1	5406701	Shaft - SLE-120
15	1	5406703	Shaft - SLE-160
15	1	5406704	Shaft - SLE-190
16	16	30212025	Screw UNI 5739 M12 x 25
17	8	34121012	Washer M12 UNI 1751
18	1	1701105	Bearing Support
19	1	1781107	Gasket
20	2	6204562	Oil Seal 45 x 62 x 10 PP
21	1	6320045	Circlip External $\phi$ 45 DIN 471
22	1	2106009	Bearing 6009
23	1	1531106	Bearing Spacer
24	1	2106209	Bearing 6209
25	1	6310085	Circlip Internal $\phi$ 85 DIN 472
26	1	30012060	Screw UNI 5737 M12 x 60
27	1	1221109	Pinion Z11 EC/30
28	1	34108012	Self Locking Nut M12 UNI 7474
29	1	6100072	Cover
30	2	6310072	Circlip Internal $\phi$ 72 DIN 472
31	2	2106207	Bearing 6207
32	1	3441018	Chonical Plug M18 x 1.5
33	1	1641101	Gearbox EC/30
34	1	3442018	Breath Plug M18 x 1.5
35	1	1221110	PTO Shaft EC/30
36	2	1321001	Free Wheel Key
37	2	1811001	Free Wheel Key Spring
38	1	6320042	Circlip External $\phi$ 42 DIN 471
39	1	1721109	Spiral Bevel Gear Z30
40	1	6203572	Oil Seal 35 x 72 x 10 PP

## PARTS LIST

<u>REF.</u>	<u>QTY.</u>	<u>PART NO.</u>	<u>DESCRIPTION</u>
41	1	5135288	PTO Shield Support
42	1	5135287	PTO Shield
43	6	34120008	Washer M8 UNI 6592
44	3	31508020	Screw M8 x 20 UNI 5739
45	5	31508016	Screw M8 x 16 UNI 5739
46	4	34118008	Washer M8 UNI 6593
47	2	34102010	Nut UNI 5588 M10
48	8	34120010	Washer M10 UNI 6592
49	1	33710096	Screw M10 L=96
50	1	5216701	Belt Tensioner Spring
51	29	5506701	Shielding Chain SLE-120
51	39	5506701	Shielding Chain SLE-160
51	46	5506701	Shielding Chain SLE-190
52	1	5006760	Chain Support Rod - SLE-120
52	1	5006762	Chain Support Rod - SLE-160
52	1	5006763	Chain Support Rod - SLE-190
53	1	5006743	Belt Cover
54	3	6721207	Belt SPA1207
55	2	6363565	Tapered Locking Unit VK 156 35/66
56	1	5646701	Driving Pulley SPA 200
57	1	4147552	Washer
58	2	2226205	Bearing 6205 2 RS
59	1	5785701	Tensioning Roller
60	1	5533008	Bearing Spacer
61	1	5006757	Belt Tensioner
62	4	34102014	Nut UNI 5588 M14
63	2	34120014	Washer M14 UNI 6592
64	1	2020035	Bearing UCFL/207
65	2	30214040	Screw M14 x 40 UNI 5739
66	6	31510020	Screw M10 x 20 UNI 5739
67	2	30210025	Screw M10 x 25 UNI 5739
68	2	34121014	Washer M14 UNI 1751
69	1	5006739	Frame - SLE-120
69	1	5006741	Frame - SLE-160
69	1	5006742	Frame - SLE-190
70	10	34026012	Schnorr Washer M12
71	1	6560010	Grease Nipple M10 UNI 7663-A
72	1	5006774	External Side Skid
73	1	5006776	External Side Protection
74	12	34120012	Washer M12 UNI 6592
75	14	34102012	Nut UNI 5588 M12
76	4	34102008	Nut UNI 5588 M8
77	3	34121008	Washer M8 UNI 1751
78	1	5134389	Nipple Cover

# PARTS LIST

<u>REF.</u>	<u>QTY.</u>	<u>PART NO.</u>	<u>DESCRIPTION</u>
79	1	5006775	Transmission Side Protection
80	12	30212030	Screw UNI 5739 M12 x 30
81	1	5646702	Driven Pulley SPA125
82	1	5006751	Closing Plate
83	1	5006773	Transmission Side Skid
84	1	5535159	Pulley Spacer
85	1	5595160	Seal Support Ring
86	2	2822207	Bearing 22207
87	1	2122207	Nilos 22207/JV
88	1	5706701	Left Rotor Support
89	44	5817101	"Y" Blade - SLE-120
89	60	5817101	"Y" Blade - SLE-160
89	72	5817101	"Y" Blade - SLE-190
90	22	5206701	Blade Link - SLE-120
90	30	5206701	Blade Link - SLE-160
90	36	5206701	Blade Link - SLE-190
91	22	5817105	Ducksfoot Blade - SLE-120
91	30	5817105	Ducksfoot Blade - SLE-160
91	36	5817105	Ducksfoot Blade - SLE-190
92	1	5006746	Rotor - SLE-120
92	1	5006748	Rotor - SLE-160
92	1	5006749	Rotor - SLE-190
93	1	5706702	Right Rotor Support
94	1	2022207	Nilos 22207/AV
95	1	6320035	Circlip External $\phi$ 35 DIN 471
96	1	5006778	Left Roller Support
97	2	2030030	Bearing UC-206
98	1	5006769	Roller - SLE-120
98	1	5006771	Roller - SLE-160
98	1	5006772	Roller - SLE-190
99	1	5006777	Right Roller Support
100	1	5786709	Rubber Shield - SLE-120
100	1	5786711	Rubber Shield - SLE-160
100	1	5786712	Rubber Shield - SLE-190
101	1	5836704	Shield Fixing Plate - SLE-120
101	1	5836706	Shield Fixing Plate - SLE-160
101	1	5836707	Shield Fixing Plate - SLE-190
102	1	EAX50062-8073	AX5 620/842 1025010-1025010 CP SS
103	4	34106012	Self Locking Nut M12 UNI 7473
104	2	34121014	Washer M14 UNI 1751
105	4	6560008	Grease Nipple M8 UNI 7663-A
106	2	4307516	Threaded Rod M12 x 25



# DRIVELINE

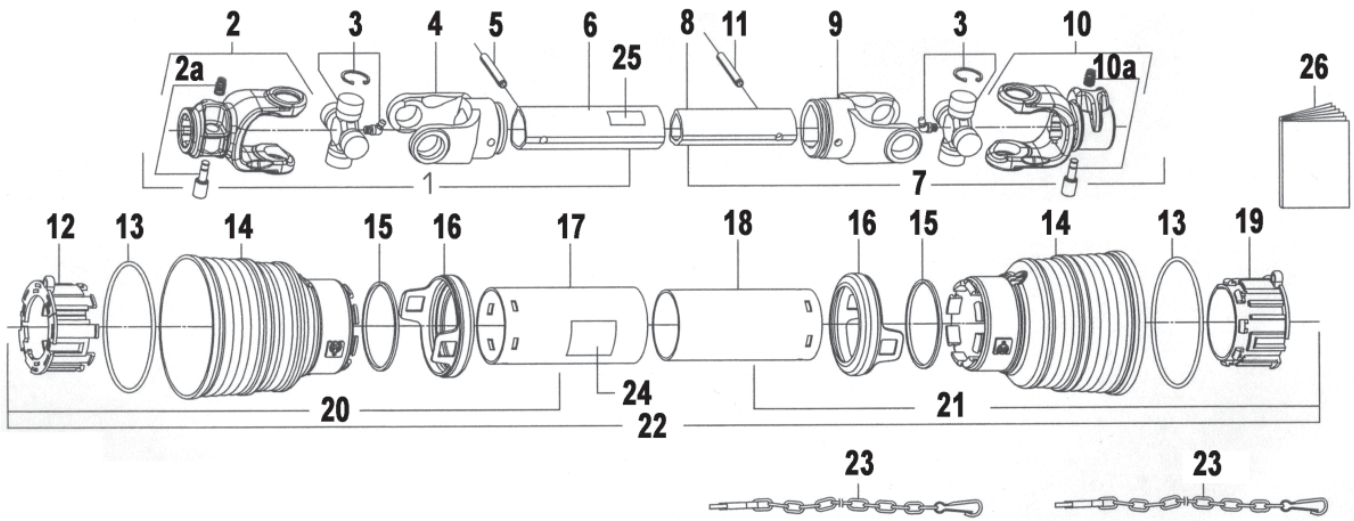

<u>REF.</u>	<u>QTY.</u>	<u>PART NO.</u>	<u>DESCRIPTION</u>
1	1	2200501	Half Outer Shaft
2	1	1025010	Yoke Assembly (Tractor End)
2a	1	1581037	Push Pin Kit
3	2	1005020	Cross Assembly
4	1	1705027	Outer Tube Yoke
5	1	6331075	10 x 75 1485 DIN Roll Pin (Outer Tube)
6	1	1527047	Outer Tube
7	1	3205510	Half Inner Shaft
8	1	1526047	Inner Tube
9	1	1705029	Inner Tube Yoke
10	1	1025010	Yoke Assembly (Implement End)
10a	1	1581037	Push Pin Kit
11	1	6331065	10 x 65 1485 DIN Roll Pin (Inner Tube)
12	1	1785710	Tube Bearing (Outer Tube)
13	2	1215733	Stiffening Ring
14	2	1785703	Standard Cone
15	2	1215735	Stop Ring
16	2	1885709	Safety Sleeve
17	1	1776037	Outer Tube Shield
18	1	1877037	Inner Tube Shield
19	1	1785711	Tube Bearing (Inner Tube)
20	1	90SX5037	Half Outer Protection
21	1	90XS5037	Half Inner Protection
22	1	90SS5037	Complete Protection
23	2	1006065	Anti-Rotation Chain
24	1	1140001	Outer Decal
25	1	1140003	Inner Decal
26	1	1140910A	User Manual

# LIMITED WARRANTY



GEARMORE, INC., warrants each new Gearmore product to be free from defects in material and workmanship for a period of twelve (12) months from date of purchase to the original purchaser. This warranty shall not apply to implements or parts that have been subject to misuse, negligence, accident, or that have been altered in any way.

Our obligation shall be limited to repairing or replacement of any part, provided that such part is returned within thirty (30) days from date of failure to Gearmore through the dealer from whom the purchase was made, transportation charges prepaid.

This warranty shall not be interpreted to render us liable for injury or damages of any kind or nature, direct, consequential or contingent, to person or property. This warranty does not extend to loss of crops, loss because of delay in harvesting or any other expenses, for any other reasons.

Gearmore in no way warrants engines, tires, or other trade accessories, since these items are warranted separately by these respective manufacturers.

Gearmore reserves the right to make improvements in design or changes in specification at any time, without incurring any obligations to owners or units previously sold.

GEARMORE, INC.  
13477 Benson Ave.  
Chino, CA 91710

Always refer to and heed machine operating warning decals on machine.

*The serial number of this product is stored in our computer database, thus submitting a warranty registration card is not required.*

## CUSTOMER INFORMATION

NAME: \_\_\_\_\_

PURCHASED FROM: \_\_\_\_\_

DATE OF PURCHASE: \_\_\_\_\_

MODEL NUMBER: \_\_\_\_\_

SERIAL NUMBER: \_\_\_\_\_