

# SureBuilt

Concrete Forms & Accessories

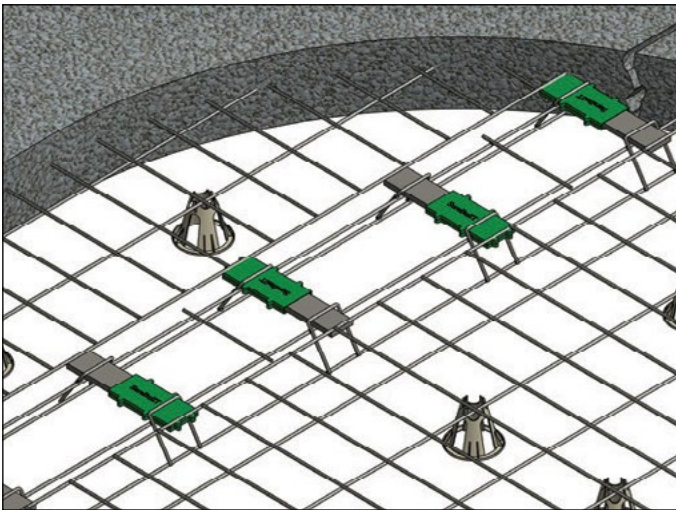

## Floor Systems & Accessories

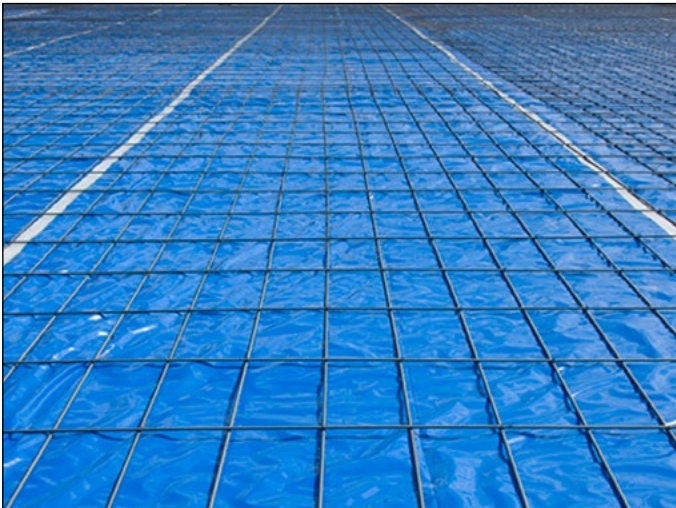



## Table of Contents

<b>Under Slab .....</b>	
VaporStop™ System .....	4
VaporStop™ Installation.....	6
<b>Slab (Internal) .....</b>	
Slab-On-Grade Chair.....	9
Bollard Base .....	10
Bollard Cap .....	10
Bollard .....	11
SureDowel Basket .....	12
SureDowel Basket Installation .....	13
Eco Dowel Basket .....	14
Eco Dowel Basket Installation .....	15
<b>Slab Placement .....</b>	
Steel Stakes.....	7
Taper Dowel.....	8
Steel Edge Nosing.....	16
Steel Edge Nosing - Wood .....	18
Steel Edge Nosing - E2N.....	20
E2N Square Dowel and Tube.....	23
Dowel Sleeve - Construction Joint.....	24
Dowel Sleeve - Expansion Joint.....	25
<b>Slab Protection .....</b>	
Curing Blanket.....	26
Curing Chemicals.....	26
Tilt-Up Profiles.....	26
Sealer.....	27

## VaporStop™ System

The VaporStop membrane system is a high performance, polyethylene barrier designed to resist moisture migration through concrete slab-on-grade. The membrane is a field-tested and cost-effective method of controlling moisture transmission in enclosed structures.

The VaporStop membrane, available in 10 mil (gray) and 15 mil (blue) thicknesses, protect the flooring, finishes and furnishings in completed structures from moisture infiltration damage. A membrane also reduces condensation, mildew and mold, while improving indoor air quality.

The VaporStop membrane meets or exceeds the “Standard Specification for Water Vapor Retarders Used in Contact with Soil or Granular Fill Under Concrete Slabs” (ASTM E-1745). The VaporStop membrane is designed to meet or exceed the Class A, B and C performance.

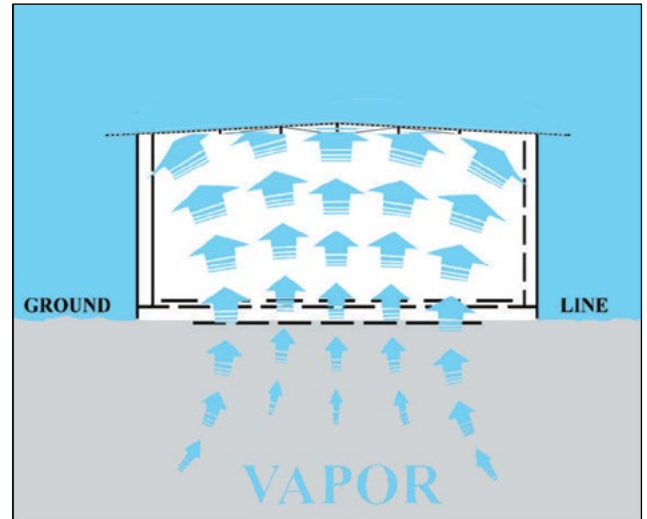

*In a structure without membrane protection, research has found that 80% of the moisture within the building originates from site ground water. (HUD Research)*



VaporStop™ System	
Part Number	Description
SBVS10	VaporStop Barrier 10mil 14'x210' (Gray)
SBVS15	VaporStop Barrier 15mil 14'x140' (Blue)
SBVSTAPE	VaporStop Tape 4"x180'

The VaporStop membrane, when properly installed (refer to page 5), will provide an effective and economical method for limiting water vapor transmission through a concrete slab on-grade. The VaporStop Tape is a polyethylene film with pressuresensitive adhesive, specifically designed to bond and seal the VaporStop membrane system. VaporStop Tape is meets or exceeds the “Standard Practice for Installation of Water Vapor Retarders Used in Contact with Soil or Granular Fill under Concrete Slabs” (ASTM E-1643).

## Description

VaporStop™ is a high-performance membrane barrier used in residential and commercial projects. It is designed for use under concrete slabs, in crawl spaces and foundation walls. It controls moisture transmission within the building interior by preventing water vapor from permeating the concrete. It greatly reduces condensation and mold formation, protecting flooring, finishes and furnishings.

## Features

- Reduces damaging moisture migration
- Extremely low moisture vapor permeability
- Outstanding tear resistance
- Exceptional impact strength
- Resists attack by organisms in contacting soil

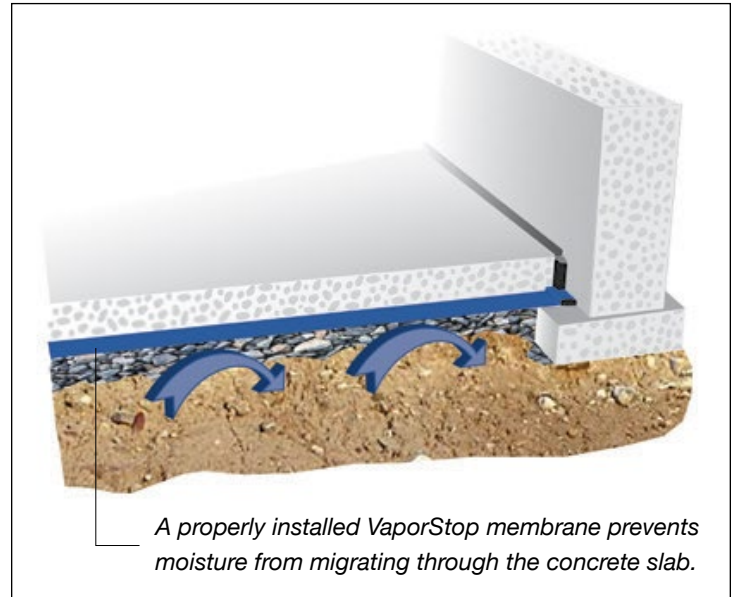

## VaporStop™ Physical Properties

Property	VaporStop 10mil	VaporStop 15mil
Nominal Thickness	10 mil	10 mil
Size	14' x 210'	14' x 140'
Weight	49 lbs/MSF	73 lbs/MSF
Tensile Strength, new (ASTM E154)	52 lb/in	88 lb/in
Tensile Strength, after soaking (ASTM E154)	53 lb/in	92 lb/in
Puncture Resistance (ASTM D1709)	2600 g	4000 g
Maximum/Minimum Use Temperature	180° / -70° F	180° / -70° F
Water Vapor Permeability, new (ASTM E154)	0.0146 Perms (grains/(ft <sup>2</sup> .hr.in.Hg))	0.009 Perms (grains/(ft <sup>2</sup> .hr.in.Hg))

## Standards

- American Concrete Institute ACI 302.1 R-04 Guide for Concrete Floor and Slab Construction
- ASTM E-154 Standard Test Methods for Water Vapor Retarders Used in Contact with Earth Under Concrete Slabs, on Walls, or as Ground Cover
- ASTM D-1709 Standard Test Methods for Impact Resistance of Plastic Film by the Free-Falling Dart Method
- ASTM E-1745 Standard Specification for Water Vapor Retarders Used in Contact with Soil or Granular Fill under Concrete Slabs
- ASTM D-1000 Standard Test Method for Pressure-Sensitive Adhesive-Coated Tapes Used for Electrical and Electronic Applications

## Storage

Store products in original, unopened, undamaged containers with identification labels intact. Protect material from exposure to ultraviolet light, excessive moisture and excessive heat.

## VaporStop™ Installation

1. Consult local building codes and any specific instructions on the project drawings before installation. Do not proceed until site conditions are acceptable and approved. Installation must comply with all applicable local, state and federal code jurisdictions. Any unacceptable conditions must be corrected before installation.



2. Level and tamp/roll the granular base as specified by the project drawings. If sharp, crushed rock is used, then a layer of 1/2" fine grade compactible fill is required between the base and the VaporStop membrane to prevent tears and punctures.
3. Unroll the VaporStop membrane with the longest dimension parallel to the direction of the planned concrete placement. For a typical floor slab, lay the VaporStop membrane over the granular base and footing, stopping at the wall and sealing the end with VaporStop Tape.
4. The VaporStop membrane should completely cover the granular base in the planned concrete placement area. All joints/seams should have a 6" overlap secured with VaporStop Tape. Keep joints/seams free from dust, dirt and moisture for maximum adhesion of the pressure-sensitive VaporStop Tape.
5. Repair any tears or punctures with a VaporStop membrane patch that has a 6" overlap in all directions and securely tape the entire patch perimeter. Keep patch area free from dust, dirt and moisture for maximum adhesion of the pressure-sensitive VaporStop Tape.
6. Use only brick-type or plate-type bar supports to protect the VaporStop membrane from puncture. Do not drive forming stakes through the VaporStop membrane.
7. All pipes, ducts or other penetrations through the VaporStop membrane must be properly sealed. Boots can be fabricated from the VaporStop material and sealed with VaporStop Tape. Cut the size and shape necessary to form a tight-fitting seal around each penetration and seal all the edges with VaporStop Tape.
8. When placing concrete on the VaporStop membrane in hot weather, use a wet curing blanket to prevent the concrete from shrinking, curling or cracking as a result of rapid surface drying.
9. Contact your SureBuilt representative for technical assistance and recommendations for usual applications or conditions.

## Steel Stakes

### Reusable stakes with nail holes for supporting lumber edge and other bracing

Steel stakes are mainly used to secure lumber or metal concrete forms in flatwork applications. Although primarily used for concrete forming, a steel stake can also be used as a general-purpose product. Other purposes include attaching screed bar brackets for flatwork finishing, securing landscape timbers, and surveying stakes.

Each stake is hot-rolled with a “pencil” point, allowing it to be easily driven or hammered into clay, rock, or compacted soil. The holes on the stakes are drilled in a spiral, meaning a nail hole will always line up with the form for quick nailing.

Steel stakes are more durable than wooden stakes and do not splinter. Steel stakes are reusable and more cost-effective because there is no need to purchase a new set for each job.

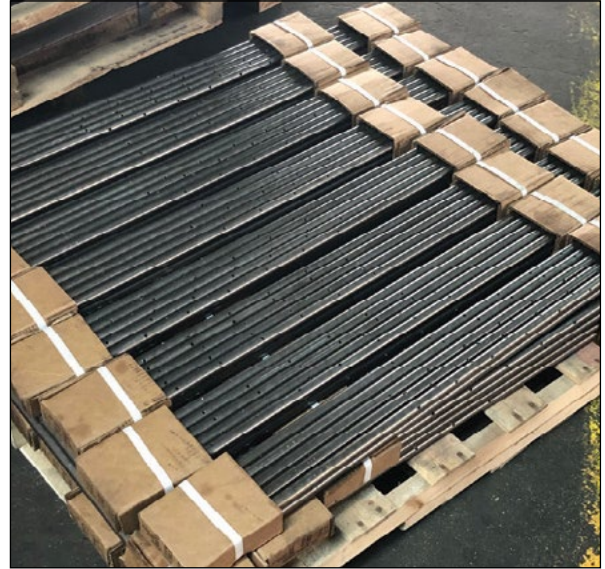

### Steel Stakes with Nail Holes - 3/4” (.718 Bar)

Part No.	Description	Weight
SBRND3418D	SB Steel Stake 3/4”x18” w/ holes	2.2
SBRND3424D	SB Steel Stake 3/4”x24” w/ holes	2.7
SBRND3430D	SB Steel Stake 3/4”x30” w/ holes	3.1
SBRND3436D	SB Steel Stake 3/4”x36” w/ holes	3.7

*\* Packaged in quantities of 10 stakes per carton*

### Steel Stakes without Nail Holes - 3/4” (.718 Bar)

Part No.	Description	Weight
SBRND3418WOHD	SB Steel Stake 3/4”x18” w/o holes	2.2
SBRND3424WOHD	SB Steel Stake 3/4”x24” w/o holes	2.7
SBRND3430WOHD	SB Steel Stake 3/4”x30” w/o holes	3.4
SBRND3436WOHD	SB Steel Stake 3/4”x36” w/o holes	4.1

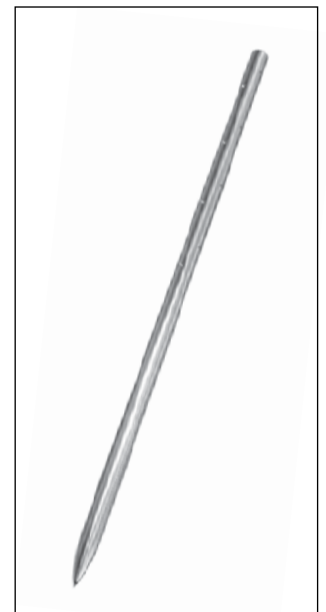

## Taper Dowel

### Diamond-shaped load transfer system for concrete joints

The size and diamond-shape of the Taper Dowel provides concrete joint stability, load transfer and smooth slab-to-slab transition, without restraining floor movement.

The plastic sleeve is nailed to lumber edge forms before concrete placement and the steel plate slides into the sleeve after forms are removed in preparation for the adjoining slab.

The plastic sleeve allows movement and the steel plate provides maximum bearing, bending and punching resistance, without the risk of slab interlock common with other methods.



### Taper Dowel Set (One Sleeve and One Plate)

Part No.	Description (height x length)	Slab	Spacing*
SBTD14SL	SB Taper Dowel 1/4" - Sleeve Only (Orange)	5" to 6-1/2"	18"
SBTD14PL	SB Taper Dowel 1/4" - Plate Only 1/4" x 4-1/2" x 4-1/2"		
SBTD38SL	SB Taper Dowel 3/8" - Sleeve Only (Yellow)	7" to 9"	18"
SBTD38PL	SB Taper Dowel 3/8" - Plate Only 3/8" x 4-1/2" x 4-1/2"		
SBTD34SL	SB Taper Dowel 3/4" - Sleeve Only (Green)	9" to 12"	18"
SBTD34PL	SB Taper Dowel 3/4" - Sleeve Only (Green)		

\* Spacing shown based on ACI 360 Design of Slabs-on-Ground.



Dowels are inserted into sleeves after edge forms have been removed.

### Dowel Specification

A properly installed plate dowel (Taper or Square) is recommended for joints up to 0.20" wide and is suitable for all types of ground level concrete slabs, such as jointed floors, flatwork and pavement. A plate dowel (Taper or Square) installation conforms to ACI 302.1R Guide for Concrete Floor and Slab Construction and ACI 360 Design of Slabs-on-Ground.



## Slab-On-Grade Chair

### Plastic supports for rebar and mesh positioning in concrete floors and pavements

The Slab-On-Grade Chair, sometimes called a castle chair or bar chair, supports rebar and mesh at the proper elevation during concrete placement.

The all-plastic, conical chair design will not corrode and supports up to 500 lbs without collapsing. Each chair accommodates two forming heights with just a quarter-turn, reducing inventory requirements and allowing for small grade variations.

The integrated base provides stability and support on soft surfaces, without damaging the moisture barrier, insulating foam or other membrane. The holes in the base can be used to fasten or tie chairs in position when necessary.

The Slab-On-Grade Chair meets the requirements to qualify as a CRSI Class 1 Bar Support.

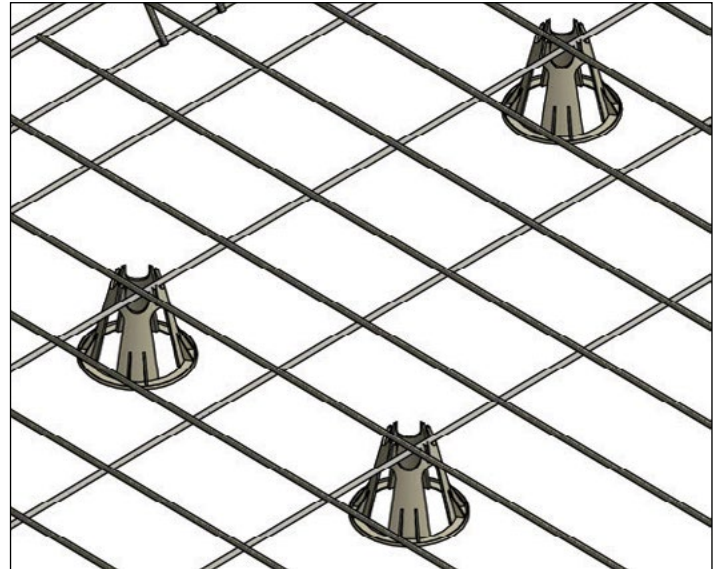

*Plastic chairs support rebar and/or mesh, often in combination with dowel baskets, in concrete floors and pavements.*



Slab-On-Grade Chair	
Part No.	Description
SBPCC1112	Slab-On-Grade Chair 1:1-1/2"
SBPCC2212	Slab-On-Grade Chair 2:2-1/2"
SBPCC3312	Slab-On-Grade Chair 3:3-1/2"
SBPCC4412	Slab-On-Grade Chair 4:4-1/2"

## Bollard Base

**Weld on bollard to base to protect concrete floor from damage**

The Bollard Base is designed to protect concrete flatwork by allowing the weld to fail between the Bollard and Bollard Base upon impact. This greatly reduces the cost.

-Ordered for slab thickness.

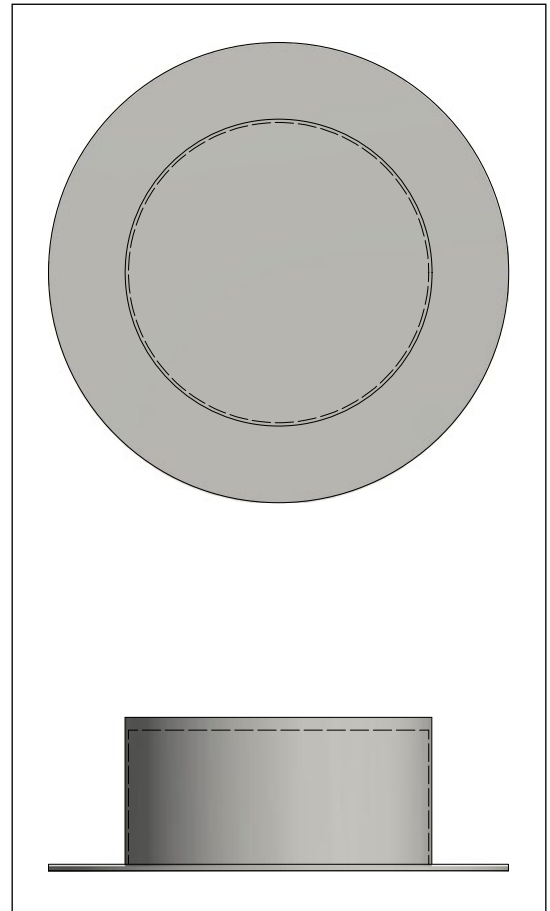

## Bollard Cap

Bollard caps provide superior building finish  
Class A form finish  
Up to 90% labor savings



## Bollard

Concrete pipe bollard that can be driven into ground, set in Bollard Base, or bolted down with bottom plate.

Available in 4 1/2", 5 1/2", 6 5/8", 8 5/8" by 7'

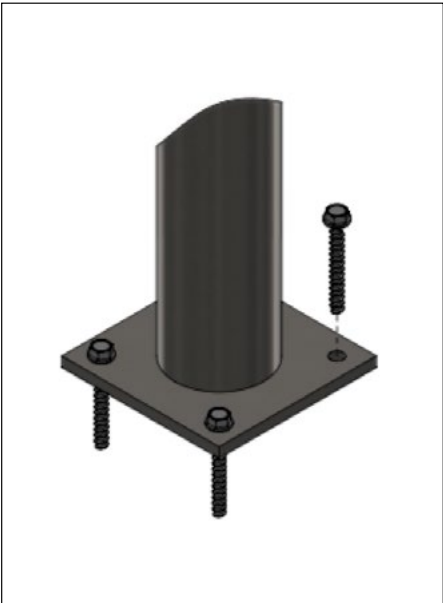
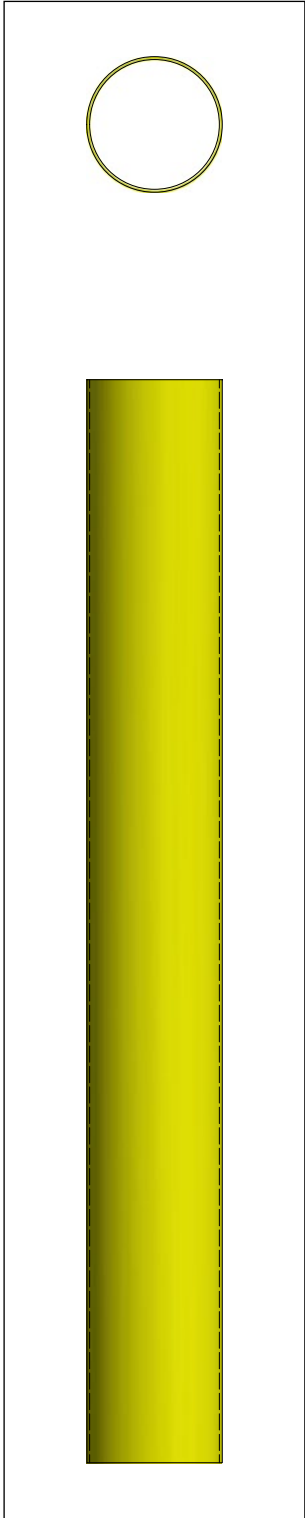

## SureDowel Basket

### Dowel assembly for concrete and pavement joint locations

The SureDowel Basket provides joint stability, reliable load transfer and smooth slab-to-slab transition, in a single cost-effective assembly.

A properly installed SureDowel Basket minimizes joint spalling, eliminates tripping hazards and improves joint filler appearance.

The patent-pending plastic sleeve allows movement and the steel plate provides bearing capacity, without the risk of slab interlock and cracking, to assure a high-quality slab.

A properly installed SureDowel Basket is recommended for joints up to 0.20" wide and is suitable for all types of ground level concrete slabs, such as jointed floors, flatwork and pavement.

A SureDowel Basket installation conforms to ACI 302.1R Guide for Concrete Floor and Slab Construction and ACI 360 Design of Slabs-on-Ground.

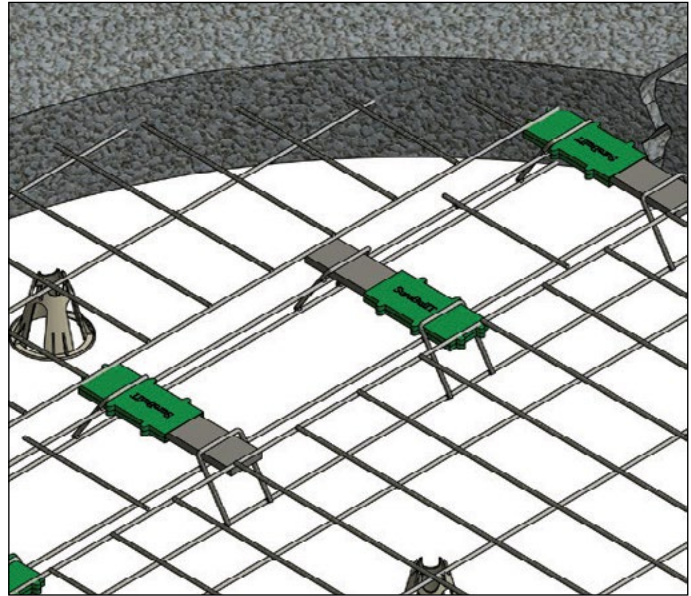

*The labor-saving 12' SureDowel Basket is placed as a single unit at every planned concrete joint, along with typical chairs and reinforcement.*

SureDowel Basket				
Part No.	Description (height x length)	Slab	Plate Size	Spacing
SBDB382S18	SB SureDowel Basket 3" x 12'	6"	3/8" x 2" x 12"	18" OC
SBDB382S24	SB SureDowel 3-1/2" x 12'	7"	3/8" x 2" x 12"	24" OC
SBDB12212S18	SB SureDowel 3-1/2" x 12'	7"	1/2" x 2-1/2" x 12"	18" OC
SBDB12212S24	SB SureDowel 4" x 12"	8"	1/2" x 2-1/2" x 12"	24" OC
SBDB34212S18	SB SureDowel 4-1/2" x 12'	9"	3/4" x 2-1/2" x 12"	18" OC
SBDB34212S24	SB SureDowel 5" x 12'	10"	3/4" x 2-1/2" x 12"	24" OC

*\* Spacing shown based on ACI 360 Design of Slabs-on-Ground.*



## SureDowel Basket Installation

1. Each SureDowel Basket should remain parallel in the horizontal plane during placing and finishing operations. Dowels should not be closer than 12" to the intersection of any joint.

2. Stake the SureDowel Basket assembly to ensure it remains in the planned joint location. Position and tie the slab reinforcement. Optional: Cut shipping wires at midpoint to reduce restraining forces at contraction joint.

3. Place concrete normally, completely surrounding each SureDowel Basket location. SureDowel Baskets require vibration to properly consolidate concrete and eliminate air entrapment. Do not strike or damage SureDowel Basket assembly with the vibrator.

4. When concrete has been finished and reaches sufficient strength, saw cut the joint along the line of each SureDowel Basket location.

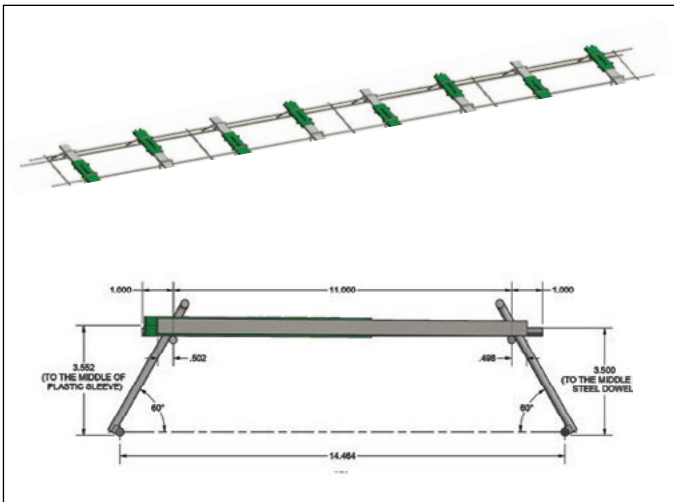

SureDowel Basket height is typically the midpoint of the slab. SureDowel Basket length is typically 12', but can be cut-to-size. Plates can be 3/8" or 1/2" or 3/4" depending on project requirements, anticipated loads and slab thickness.

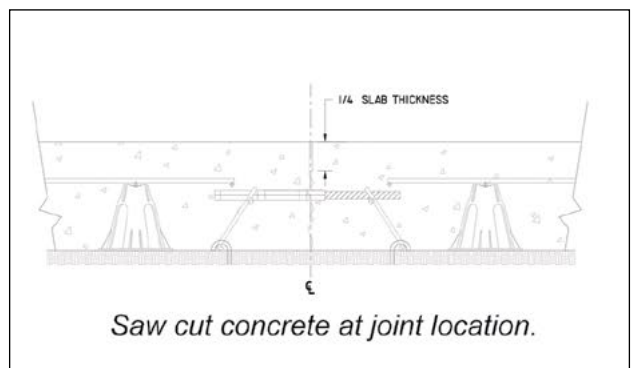
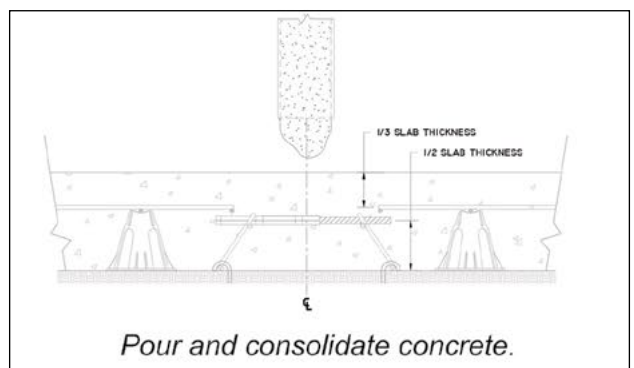
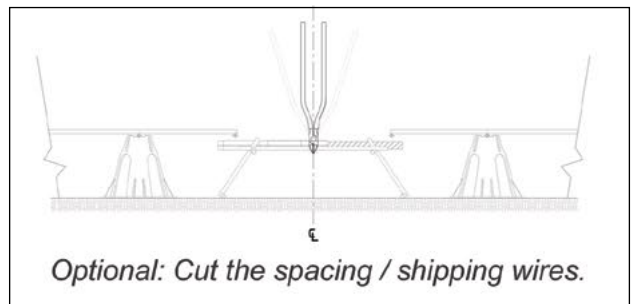
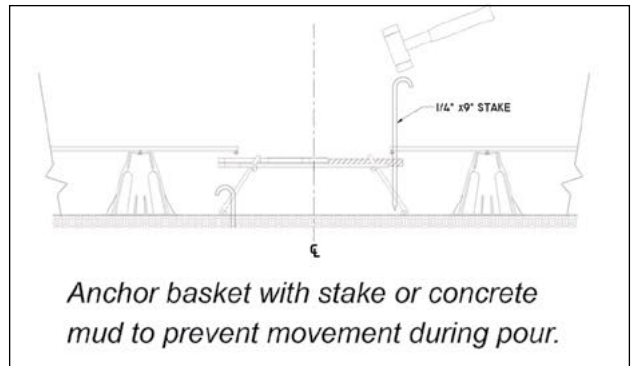
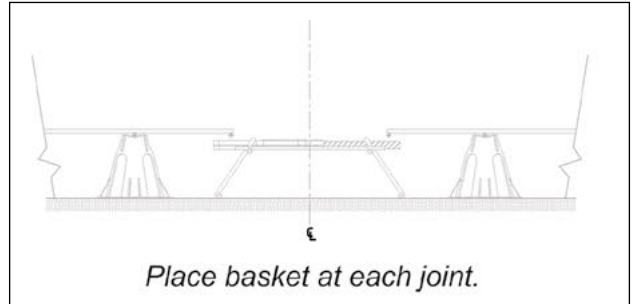

## ECO Dowel Basket

**Tapered dowel assembly for efficient load transfer in concrete floor and pavement joints**

The ECO Dowel Basket provides joint stability, reliable load transfer and smooth slab-to-slab transition, in a single cost-effective assembly. A properly installed ECO Dowel Basket minimizes joint spalling.

The diamond-shaped steel plate allows axial and lateral movement, provides bearing capacity, and prevents slab interlock and cracking, assuring a high quality concrete slab. A properly installed ECO Dowel Basket is designed for joints up to 0.20" wide and is suitable for all types of ground level concrete slabs, such as jointed floors, flatwork and pavement.

An ECO Dowel Basket conforms to ACI 302.1R Guide for Concrete Floor and Slab Construction and ACI 360 Design of Slabs-on-Ground.

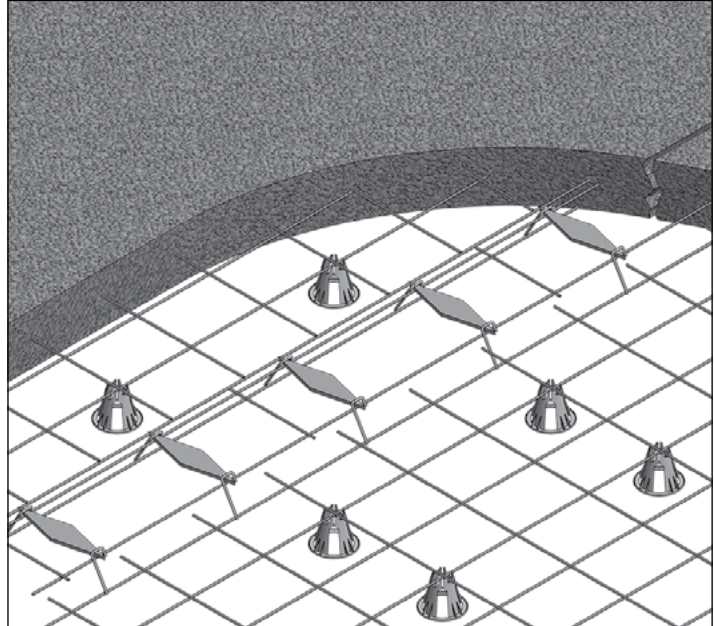

### ECO Dowel Basket

Part No.	Description (height x length)	Slab	Plate Size	Spacing
SBEDB638S18	ECO Dowel Basket 3" x 12'	6"	3/8" x 3" x 12"	18" OC
SBEDB738S24	ECO Dowel Basket 3-1/2" x 12'	7"	3/8" x 3" x 12"	24" OC
SBEDB712S18	ECO Dowel Basket 3-1/2" x 12'	7"	1/2" x 3" x 12"	18" OC
SBEDB812S24	ECO Dowel Basket 4" x 12'	8"	1/2" x 3" x 12"	24" OC
SBEDB934S18	ECO Dowel Basket 4-1/2" x 12'	9"	3/4" x 3" x 12"	18" OC
SBEDB1034S24	SB Dowel Basket 5" x 12'	10"	3/4" x 3" x 12"	24" OC
SBEDBDA	ECO Debond - 5 Gal Pail	Coats tapered dowel for movement within slab		

\* Spacing shown based on ACI 360 Design of Slabs-on-Ground.  
Additional spacing specifications available upon request.

## ECO Dowel Basket Installation

1. ECO Dowel Baskets are supplied with ECO Debond agent.
2. Each ECO Dowel Basket should remain parallel in the horizontal plane during concrete placing and finishing operations.
3. Tapered dowels should not be closer than 12" to the intersection of any joint. Adjust basket position to avoid this condition.
4. Anchor basket with stake or concrete mud to prevent movement during pour. Position and tie the slab reinforcement. Optional: Cut shipping wires at midpoint to reduce restraining forces at contraction joint.
5. Place concrete, completely surrounding each ECO Dowel Basket location. Use vibration to consolidate concrete, but do not strike or damage the assembly.
6. When concrete has been finished and reaches sufficient strength, saw cut the joint along the line of each ECO Dowel Basket location.

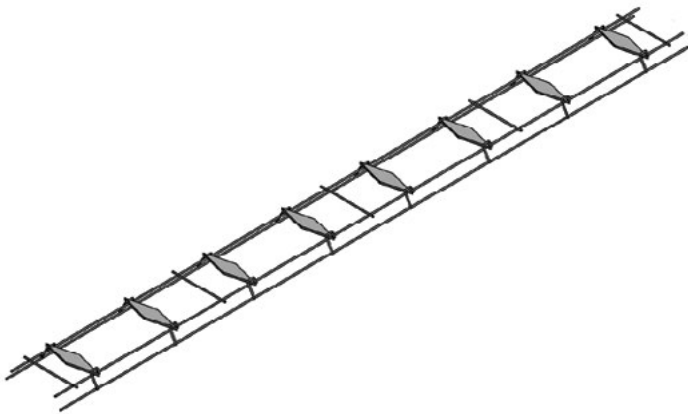

ECO Dowel Basket height is typically the midpoint of the slab. Basket length is typically 12', but can be cut-to-size. Plates can be 3/8" or 1/2" or 3/4" depending on project requirements, anticipated loads and slab thickness.

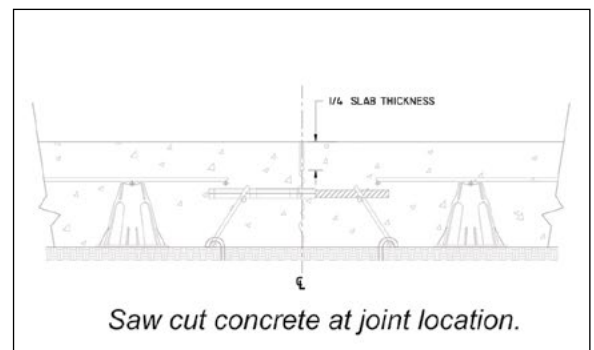
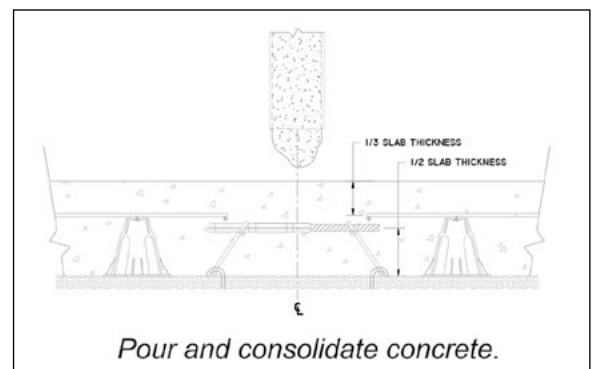
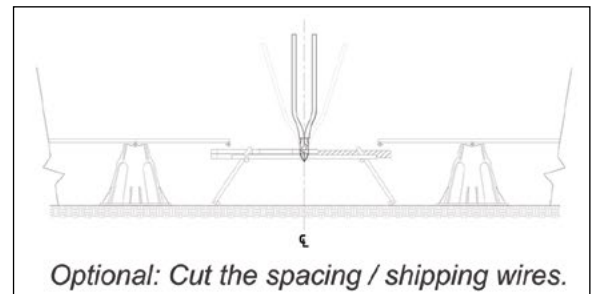
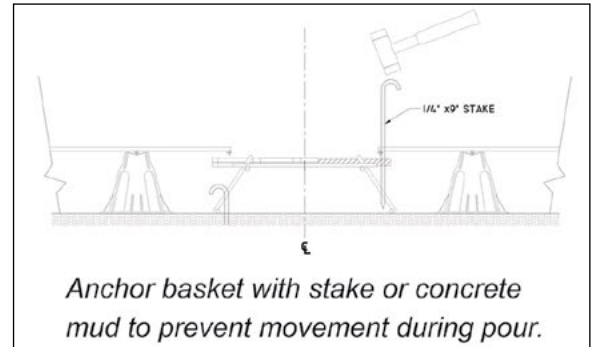
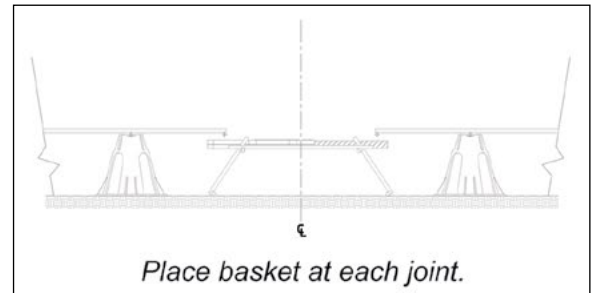

## Steel Edge Nosing

### Joint edge protection and precise load transfer in a single assembly

High-traffic industrial floors and pavements require precise load transfer, smooth slab-to-slab transition and joint protection. All of these requirements are met with the Steel Edge Nosing assembly.

A complete assembly includes the steel nosing, studs, dowel plates and full-depth channel for joint installations. The leave-in-place design eliminates conventional slab edge forming costs.

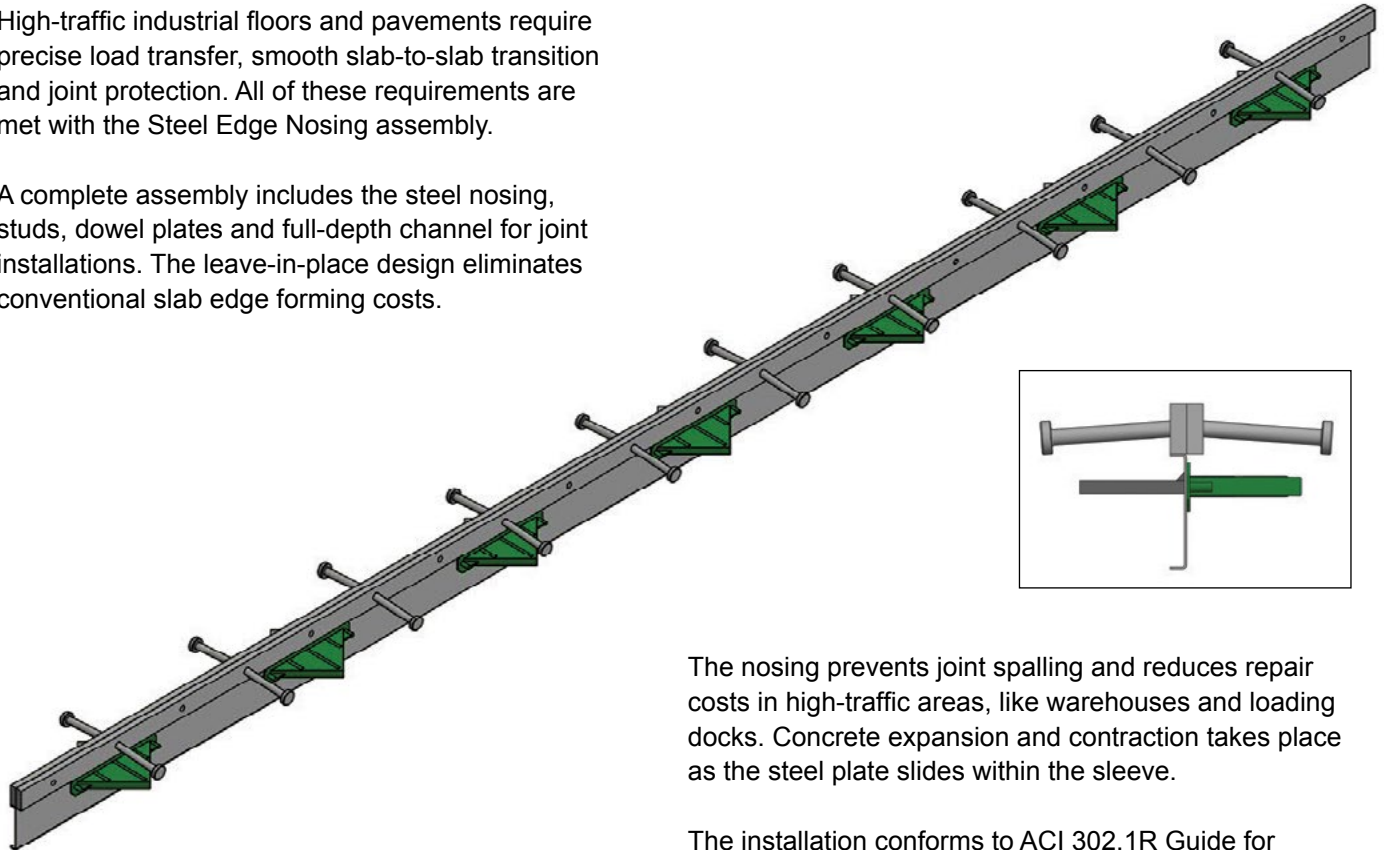

The nosing prevents joint spalling and reduces repair costs in high-traffic areas, like warehouses and loading docks. Concrete expansion and contraction takes place as the steel plate slides within the sleeve.

The installation conforms to ACI 302.1R Guide for Concrete Floor and Slab Construction and ACI 360 Design of Slabs-on-Ground.

### Steel Edge Nosing with Taper Dowel

Part No.	Description (height x length)	Slab	Plate Size	Spacing*
SBSEN6	SB Steel Edge Nosing 6"x10'	6"	1/4" x 4-1/2" x 4-1/2"	18"
SBSEN6WC	SB Steel Edge Nosing 6"x10' w/ Clip	6"	1/4" x 4-1/2" x 4-1/2"	18"
SBSEN7	SB Steel Edge Nosing 7"x10'	7"	3/8" x 4-1/2" x 4-1/2"	18"
SBSEN7WC	SB Steel Edge Nosing 7"x10' w/ Clip	7"	3/8" x 4-1/2" x 4-1/2"	18"
SBSEN8	SB Steel Edge Nosing 8"x10'	8"	3/8" x 4-1/2" x 4-1/2"	18"
SBSEN8WC	SB Steel Edge Nosing 8"x10' w/ Clip	8"	3/8" x 4-1/2" x 4-1/2"	18"



## Steel Edge Nosing Installation

1. Steel Edge Nosing assemblies should be placed in the planned joint location. Dowel plates should be no closer than 6" to joint intersections.
2. Steel Edge Nosing assemblies should remain plumb/parallel during placing. Position, support and tie slab reinforcement to the studs.
3. Place concrete normally, completely surrounding each dowel sleeve/plate location. Vibration is required to properly consolidate concrete and eliminate air entrapment. Do not strike or damage sleeves/plates with the vibrator.
4. The Steel Edge Nosing, with studs tied to the concrete slab reinforcement, provides joint edge protection and a smooth transition under load from one concrete section to another.

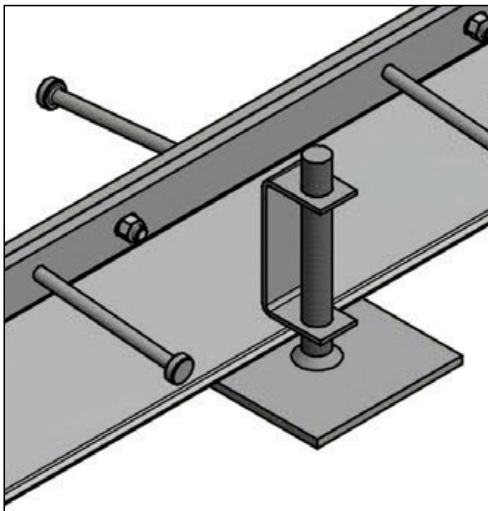

*Optional welded Clips can be provided to support the assembly, using Steel Stakes or Base Plates (as shown).*

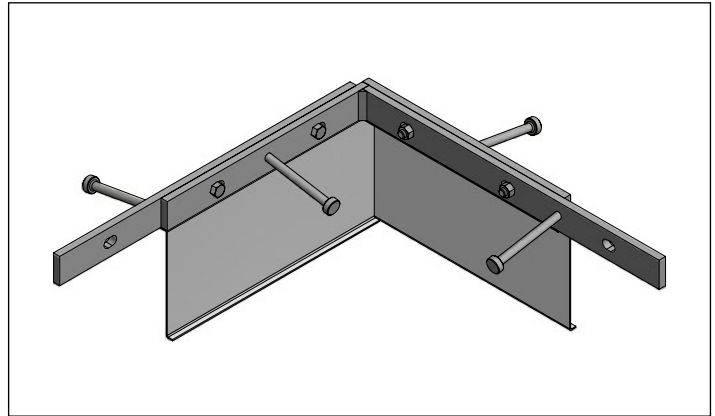

*Steel Edge Nosing w/ Clip - 2-Way Intersection*

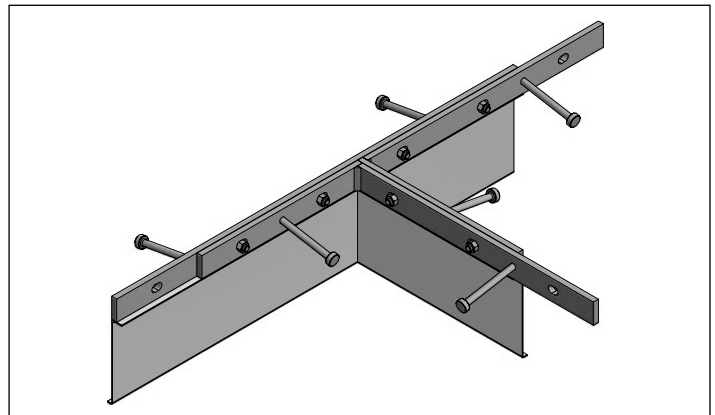

*Steel Edge Nosing w/ Clip - 3-Way Intersection*

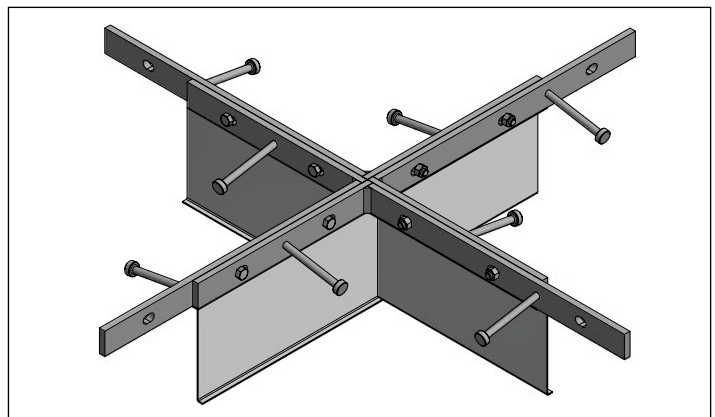

*Steel Edge Nosing w/ Clip - 4-Way Intersection*

## Steel Edge Nosing - Wood

### Joint edge protection and integrated load transfer

High-traffic industrial floors and pavements require precise load transfer, smooth slab to slab transition and joint protection. All of these requirements are met with the Steel Edge Nosing-Wood assembly.

A complete assembly includes the steel nosing, studs, dowel plates and full-depth channel for joint installations. The leave-in-place design eliminates conventional slab edge forming costs.

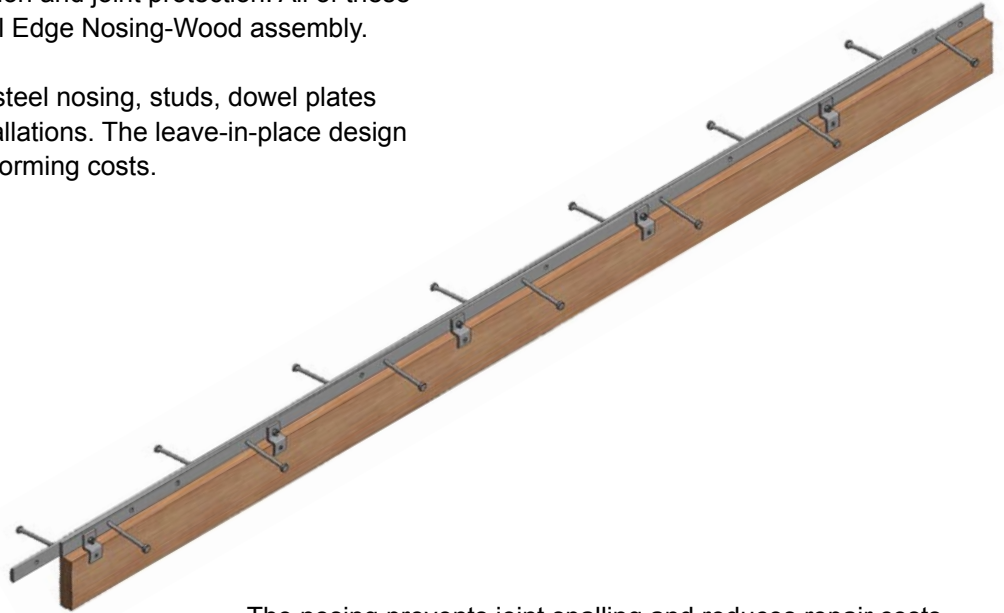
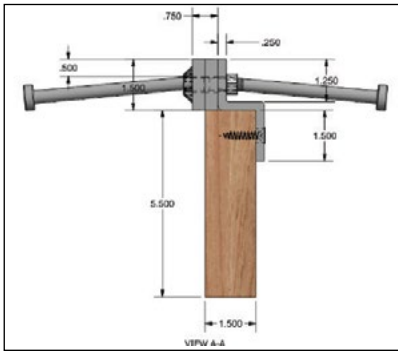

The nosing prevents joint spalling and reduces repair costs in high-traffic areas, like warehouses and loading docks. Concrete expansion and contraction takes place as the steel plate slides within the sleeve.

The installation conforms to ACI 302.1R Guide for Concrete Floor and Slab Construction and ACI 360 Design of Slabs-on-Ground.

### Dowel Sleeve and Nailing Plate for Construction Joints\*

Part No.	Description (height x length)	Slab	Plate Size	Spacing*
SBSEN6	SB Steel Edge Nosing 6"x10'	6"	1/4" x 4-1/2" x 4-1/2"	18"
SBSEN6WC	SB Steel Edge Nosing 6"x10' w/ Clip	6"	1/4" x 4-1/2" x 4-1/2"	18"
SBSEN7	SB Steel Edge Nosing 7"x10'	7"	3/8" x 4-1/2" x 4-1/2"	18"
SBSEN7WC	SB Steel Edge Nosing 7"x10' w/ Clip	7"	3/8" x 4-1/2" x 4-1/2"	18"
SBSEN8	SB Steel Edge Nosing 8"x10'	8"	3/8" x 4-1/2" x 4-1/2"	18"
SBSEN8WC	SB Steel Edge Nosing 8"x10' w/ Clip	8"	3/8" x 4-1/2" x 4-1/2"	18"

\* Spacing shown based on ACI 360 Design of Slabs-on-Ground.

## Steel Edge Nosing - Wood Installation

1. Steel Edge Nosing-Wood assemblies should be placed in the planned joint location. Dowel plates should be no closer than 6" to joint intersections.
2. Steel Edge Nosing-Wood assemblies should remain plumb/parallel during placing. Position, support and tie slab reinforcement to the studs.
3. Place concrete normally, completely surrounding each dowel sleeve/plate location. Vibration is required to properly consolidate concrete and eliminate air entrapment. Do not strike or damage sleeves/plates with the vibrator.
4. Steel Edge Nosing-Wood, with studs tied to the concrete slab reinforcement, provides joint edge protection and a smooth transition under load from one concrete section to another.

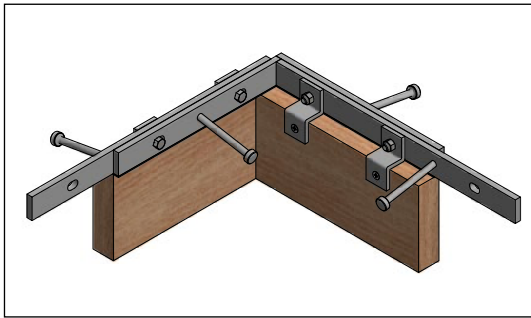

Steel Edge Nosing w/ Clip - 2-Way Intersection

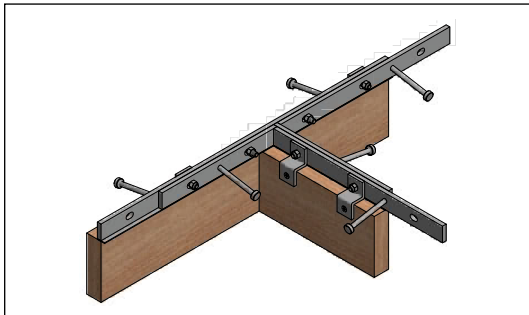

Steel Edge Nosing w/ Clip - 3-Way Intersection

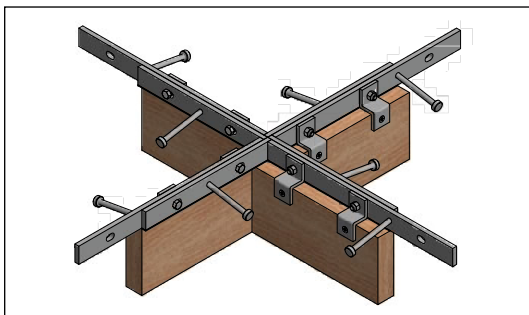

Steel Edge Nosing w/ Clip - 4-Way Intersection

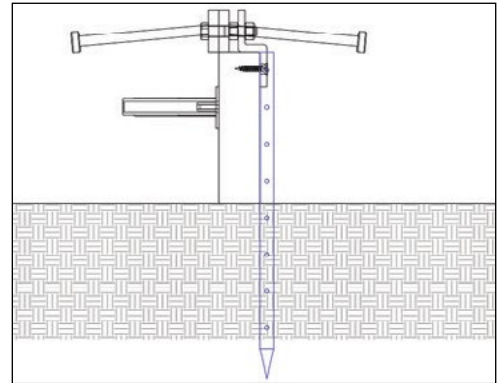

Step 1: Place Wood Form to Height with Top Rail.

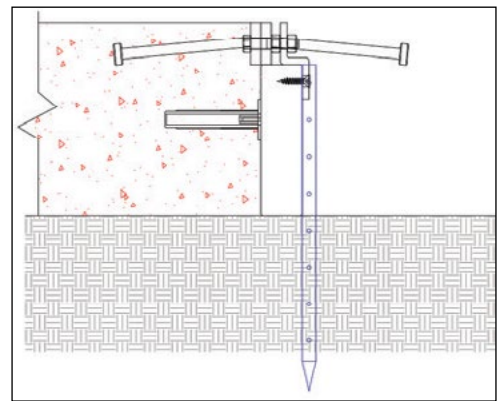

Step 2: Place Taper Sleeve in Form, Pour Concrete one side.

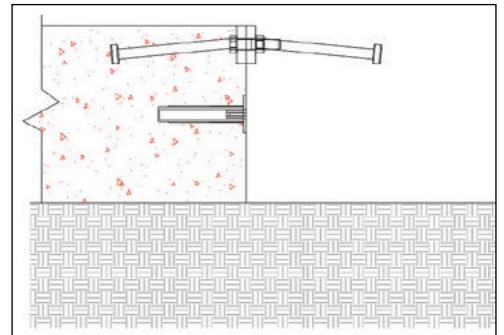

Step 3: Remove Wood Form and Fastener Clip.

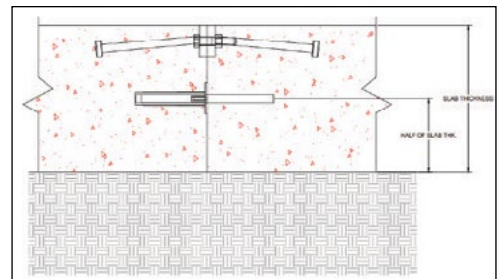

Step 4: Place Taper Dowel and Pour Other Side.

## Steel Edge Nosing - E2N

### Stabilize construction joints for existing to new concrete

Additions to high-traffic industrial floor buildings and pavements require precise load transfer, smooth slab-to-slab

transition and joint protection. All of these requirements are met with the Steel Edge Nosing - E2N assembly.

A complete assembly includes the steel nosing, studs, square dowels and full-depth channel for joint

installations. The leave-in-place design eliminates conventional slab edge forming costs.

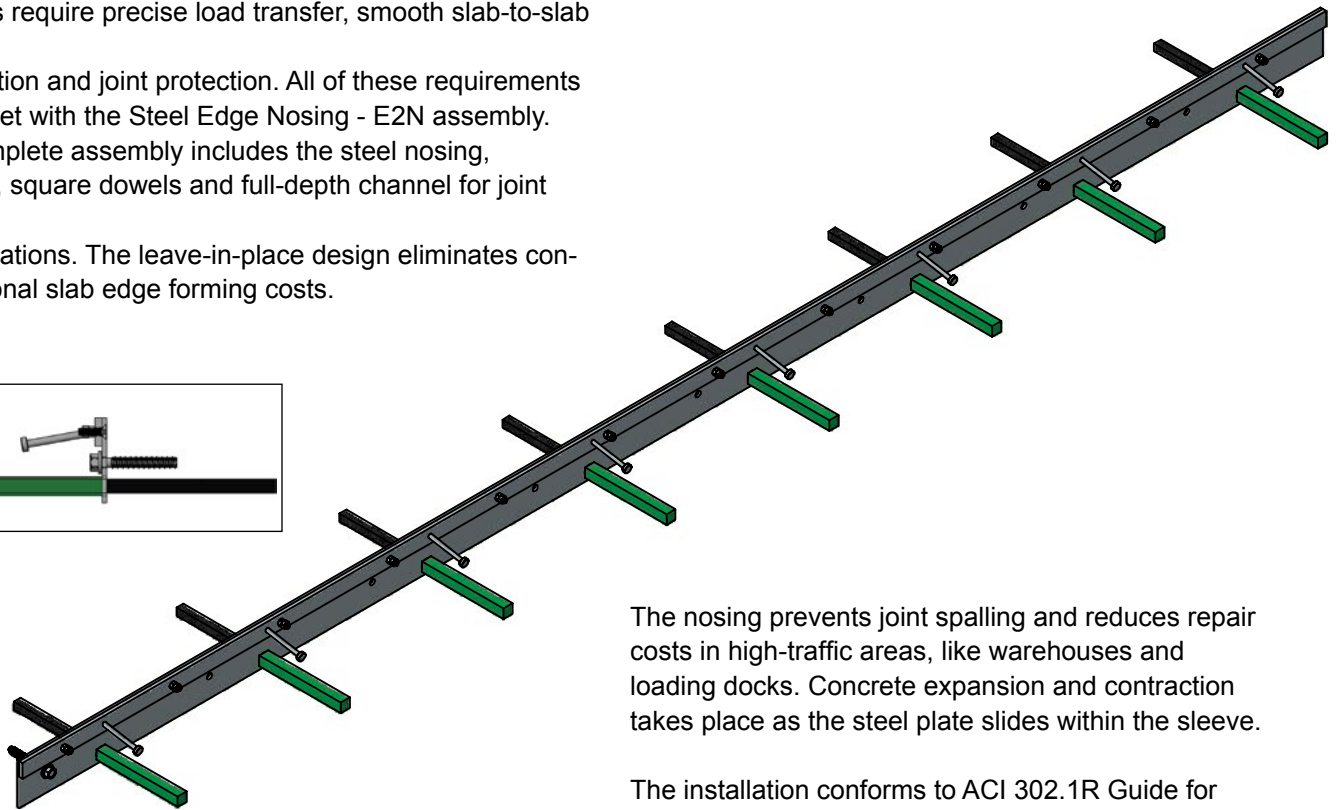
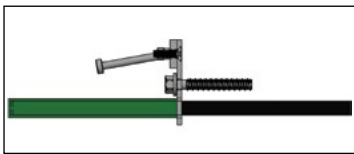

The nosing prevents joint spalling and reduces repair costs in high-traffic areas, like warehouses and loading docks. Concrete expansion and contraction takes place as the steel plate slides within the sleeve.

The installation conforms to ACI 302.1R Guide for Concrete Floor and Slab Construction and ACI 360 Design of Slabs-on-Ground.

### Steel Edge Nosing - E2N

Part No.	Description (height x length)	Slab	Dowel Size	Spacing*
SBSENE2N6	Seel Edge Nosing 6"x10'	6"	3/4" x 3/4" x 18"	18"
SBSENE2N6DT	Seel Edge Nosing 6"x10" w/ Dowel & Tube	6"	3/4" x 3/4" x 18"	18"
SBSENE2N7	Steel Edge Nosing 7"x10'	7"	3/4" x 3/4" x 18"	18"
SBSENE2N7DT	Steel Edge Nosing 7"x10' w/ Dowel & Tube	7"	3/4" x 3/4" x 18"	18"
SBSENE2N8	Steel Edge Nosing 8"x10'	8"	3/4" x 3/4" x 18"	18"
SBSENE2N8T	Steel Edge Nosing 8"x10' w/ Dowel & Tube	8"	3/4" x 3/4" x 18"	18"
SBSENE2N9	Steel Edge Nosing 9"x10'	9"	3/4" x 3/4" x 18"	18"
SBSENE2N9DT	Steel Edge Nosing 9"x10' w/ Dowel & Tube	9"	3/4" x 3/4" x 18"	18"
SBSENE2N10	Steel Edge Nosing 10"x10'	10"	3/4" x 3/4" x 18"	18"
SBSENE2N10DT	Steel Edge Nosing 9"x10' w/ Dowel & Tube	10"	3/4" x 3/4" x 18"	18"

## Steel Edge Nosing - E2N Installation

1. Position and hold steel plate and steel bar flush with the surface of the existing slab. Mark the locations of the hole in the steel plate for the square dowels and anchor bolts. Remove Steel Edge Nosing - E2N.
2. Drill holes 10" into slab, parallel to slab surface using 1-4" drill bit for the 3/4" square dowels. Drill holes 4-1/2" into slab, parallel to slab surface using 1/2" drill bit. Attach joint assembly to existing slab with anchor bolts. Check assembly for flush elevation and adjust as needed.
3. Epoxy grout 3/4" x 18" square dowels with dowel tube into pre-drilled holes so that dowel sleeve is flush with existing concrete surface. Dowel with sleeve must be installed so that it is wider than it is tall to allow side-to-side movement. Allow epoxy to cure.
4. If the Steel Edge Nosing - E2N will butt up to a sawcut contraction joint, cut through the full depth of the side of the Steel Edge Nosing that abuts the saw-cut to allow activation of the joint.
5. Remove the steel alignment nut from nut and bolt alignment assembly to allow joint to activate.
6. Place and finish concrete normally. Vibration is required to properly consolidate concrete and eliminate air entrapment. Do not strike or damage sleeves/plates with the vibrator.
7. Concrete paste can be removed from top of Steel Edge Nosing - E2N plate and bar during finishing.
8. If concrete leveling is needed, grind joint flush or saw-cut 1/2" deep, 18 - 24 inches back into existing slab, chip existing slab down 1/2 - 3/4" and top with approved epoxy materials.
9. See project specifications for joint filler installation.

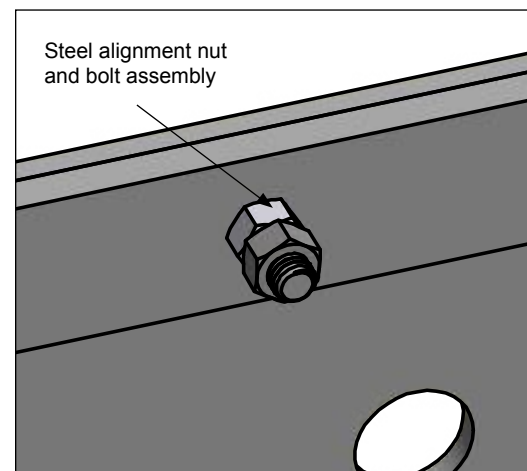
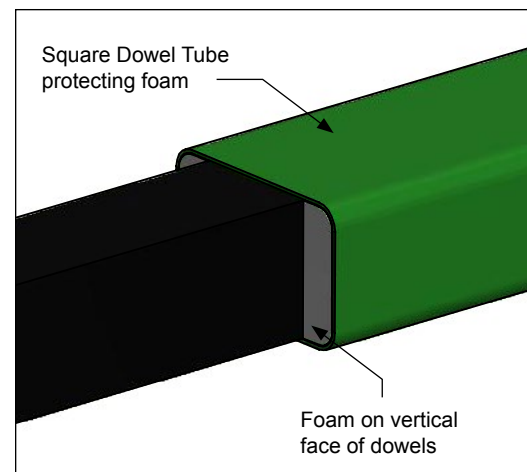
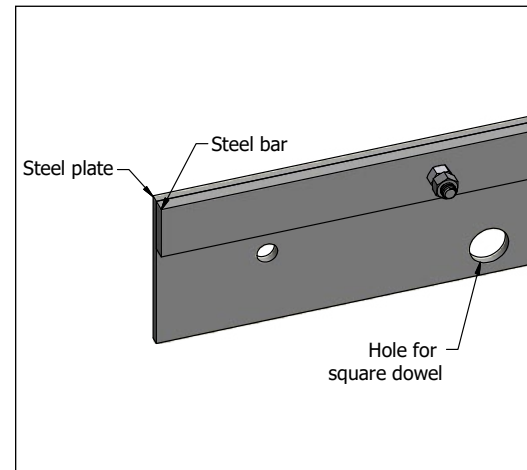

## E2N Square Dowel and Tube

### Stabilize construction joints for existing to new concrete floors and flatwork

Designed for joint activation and free horizontal movement of existing-to-new concrete without restraint.

The E2N Square Dowel and Tube has compressible foam on both sides of the 3/4" square steel dowel protected by a plastic tube.

This allows new concrete to shrink adjacent to existing concrete without the dowel causing unintended damage to the concrete.

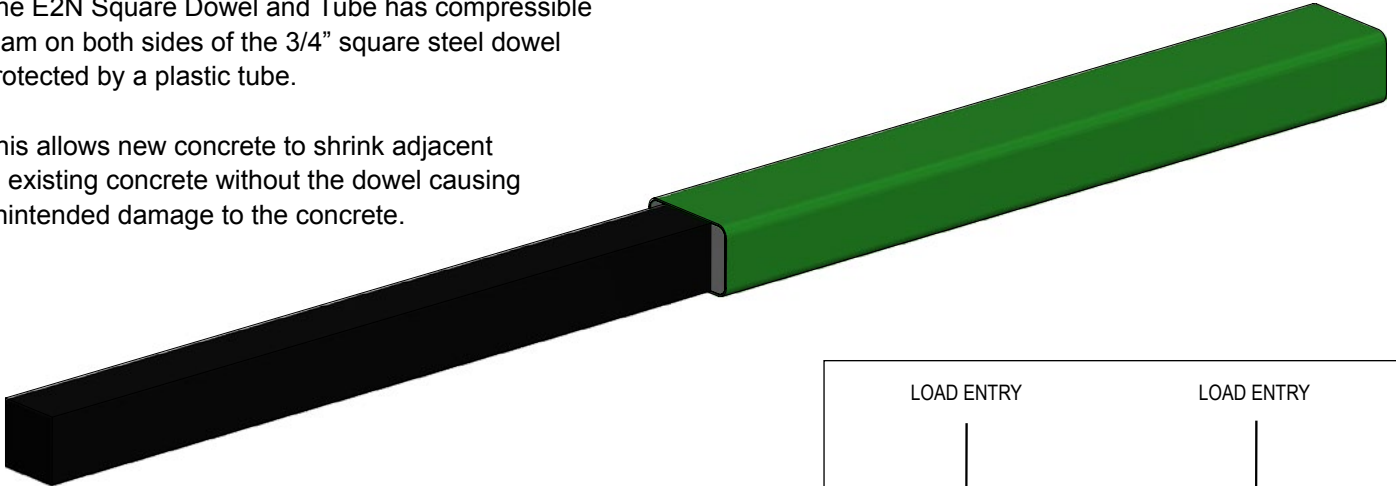

The comparison to the right shows the load transfer on square bars compared to round bars. The load transfer directly down into the concrete effectively eliminates splitting stresses within the concrete.

Square bars have greater resistance to bending, reducing edge and corner curling without increasing the amount of steel used.

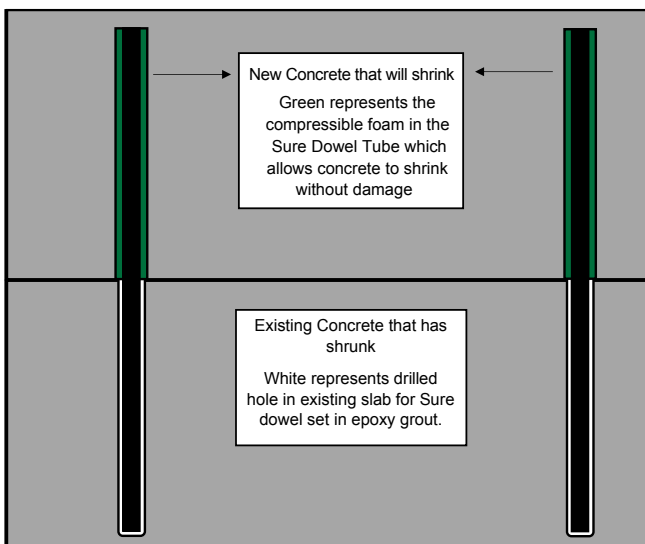
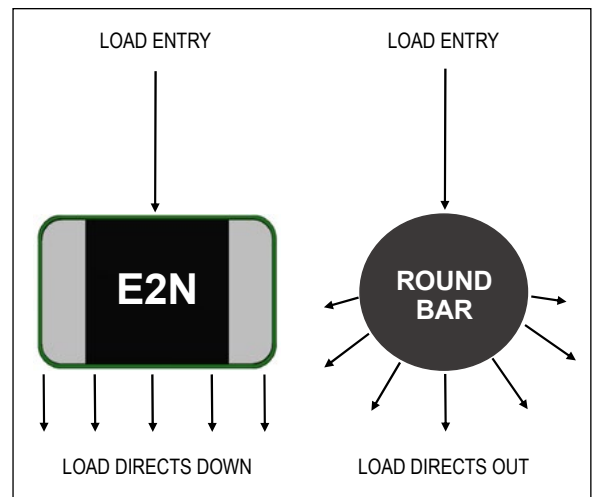

## E2N Square Dowel and Tube Installation Guide

1. Drill 1-1/8" hole to 9-1/2" at mid-slab depth. Space E2N Square Dowels at 18" O.C.



2. Set E2N Square Dowel and Tube in epoxy grout with Tube flush with existing slab.

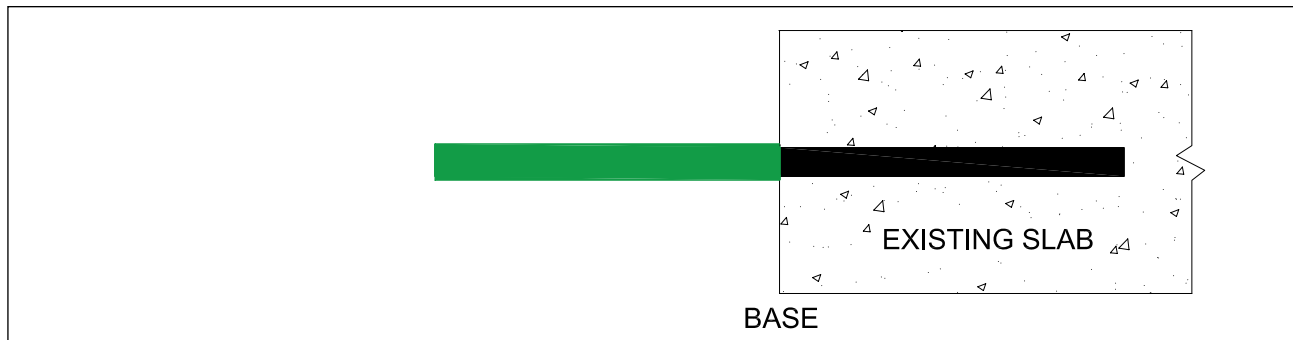

3. Place and finish new concrete.

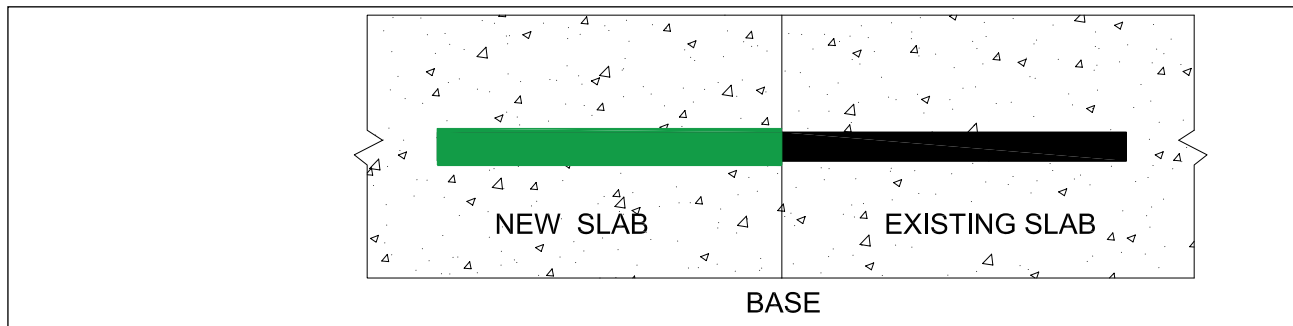

Part No.	Description	Slab Thickness	Square Dowel Size	Dowel Length	Square Dowel Clip Length	Embedment (in)
SBE2NSD18	Square Dowel	any	0.5"	9"	9"	9"
SBE2NSDT9	Square Dowel Tube					

## Dowel Sleeve - Construction Joint

**Used with lumber edge forms to accurately position smooth steel dowels at a construction joint**

Positioning smooth dowels with lumber edge forms is easy with the plastic Dowel Sleeve and Nailing Plate. The plate is attached to the form at the required spacing and the sleeve is pushed onto the plate before concrete placement.

When the lumber edge forms are removed, a smooth steel dowel is placed into each sleeve for the adjoining concrete slab. The plastic Dowel Sleeve holds each dowel in proper horizontal alignment for the best possible load transfer between sections.

Normal concrete expansion and contraction takes place as the smooth steel dowel slides inside the plastic sleeve.

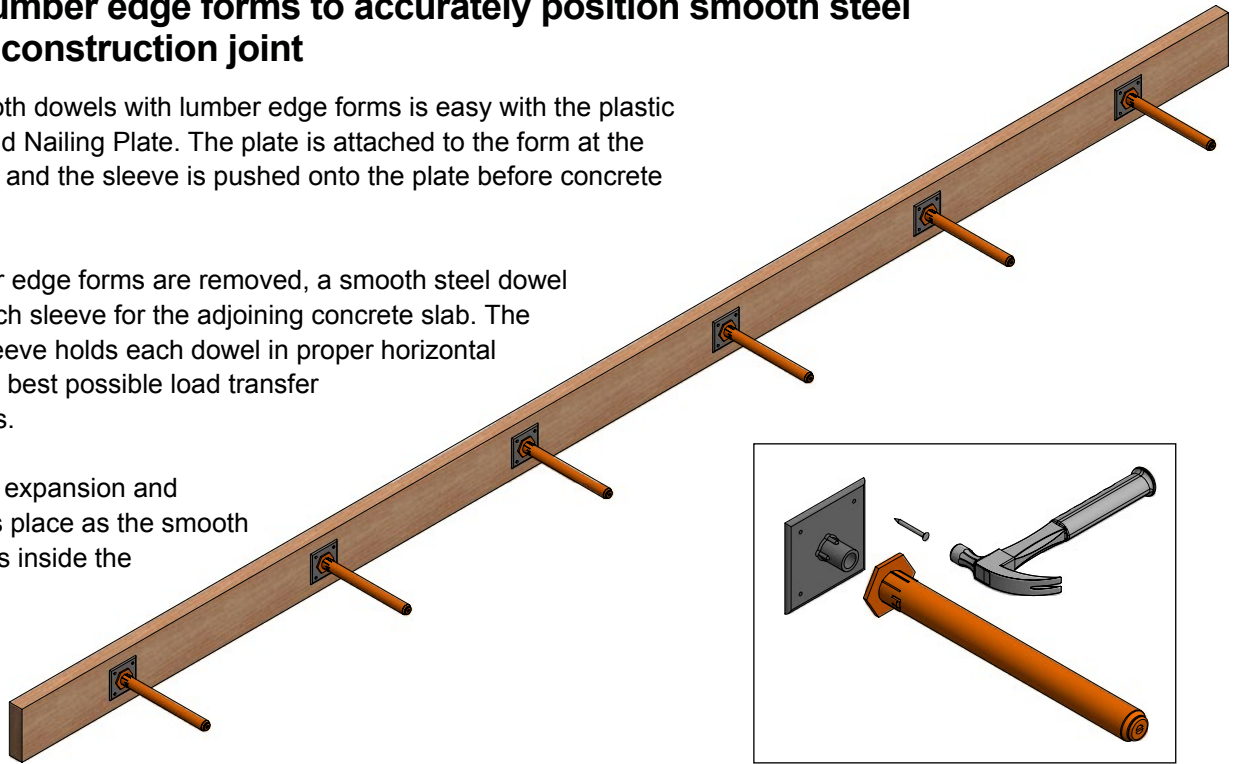

### Dowel Sleeve and Nailing Plate for Construction Joints\*

Part No.	Description	Sleeve Diameter	Sleeve Length	Dowel Size**
SBDSCJ129	SB Dowel Sleeve and Nailing Plate - 1/2" x 9"	1/2"	9"	1/2" x 18"
SBDSCJ349	SB Dowel Sleeve and Nailing Plate - 3/4" x 9"	3/4"	9"	3/4" x 18"
SBDSCJ19	SB Dowel Sleeve and Nailing Plate - 1" x 9"	1"	9"	1" x 18"
SBDSCJ1149	SB Dowel Sleeve and Nailing Plate - 1-1/4" x 9"	1-1/4"	9"	1-1/4" x 18"

\*Consult project engineer for required dowel size and spacing

\*\* Dowels Sold Separately

### Smooth Steel Dowel

Part No.	Description
SBDWL1218	SB Smooth Steel Dowel 1/2" x 18"
SBDWL3418	SB Smooth Steel Dowel 3/4" x 18"
SBDWL118	SB Smooth Steel Dowel 1" x 18"
SBDWL11418	SB Smooth Steel Dowel 1-1/4" x 18"



## Dowel Sleeve - Expansion Joint

**Used with stay-in-place expansion board to accurately position smooth dowels**

Positioning smooth dowels with leave-in-place expansion boards, like cedar or polypropylene, is easy with the Dowel Sleeve.

Expansion boards are predrilled to the proper hole size and spacing to meet specifications. Once the predrilled boards are in position, the sleeves are quickly snapped into place. Integrated collar tabs keep each sleeve in position and perpendicular to the board face.

The plastic sleeve holds each smooth steel dowel in proper horizontal alignment for the best possible load transfer between concrete pavement sections.

Normal concrete expansion and contraction takes place as the smooth steel dowel bar slides inside the sleeve.

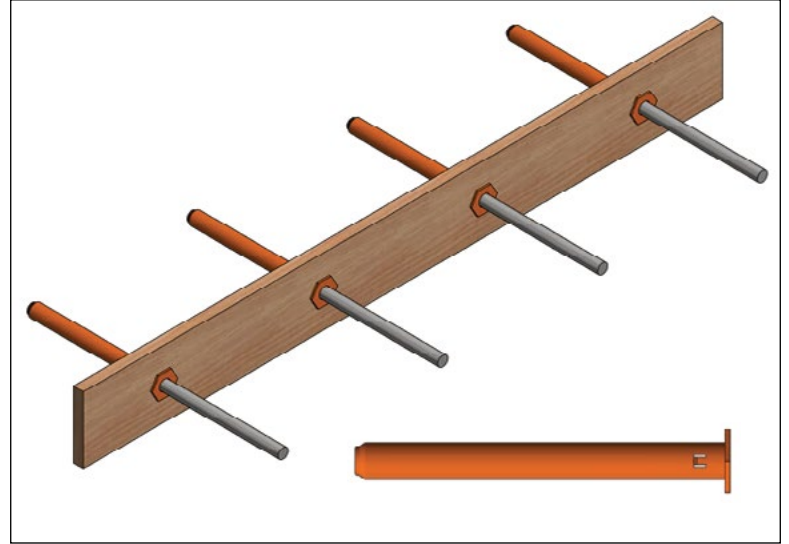

*Plastic sleeves are used with predrilled expansion boards, like cedar or polypropylene, to accurately position and align smooth steel dowels in the adjoining concrete section.*

### Dowel Sleeve for Expansion Board\*

Part No.	Description	Sleeve Diameter	Sleeve Length	Dowel Size**
SBDSEJ129	SB Dowel Sleeve for Expansion Board 1/2" x 9"	1/2"	9"	1/2" x 18"
SBDSEJ349	SB Dowel Sleeve for Expansion Board 3/4" x 9"	3/4"	9"	3/4" x 18"
SBDSEJ19	SB Dowel Sleeve for Expansion Board 1" x 9"	1"	9"	1" x 18"
SBDSEJ1149	SB Dowel Sleeve for Expansion Board 1-1/4" x 9"	1-1/4"	9"	1-1/4" x 18"

\*Consult project engineer for required dowel size and spacing

\*\* Dowels Sold Separately

### Smooth Steel Dowel

Part No.	Description
SBDWL1218	SB Smooth Steel Dowel 1/2" x 18"
SBDWL3418	SB Smooth Steel Dowel 3/4" x 18"
SBDWL118	SB Smooth Steel Dowel 1" x 18"
SBDWL11418	SB Smooth Steel Dowel 1-1/4" x 18"

## Curing Concrete

The Slab Therapy System is for compatability from start to finish

## Curing Blanket

Superior hydration, less discoloration, and even cure of slab

<b>SureCure SOG</b> Single-use, non-woven engineered absorbent fabric, Exceeds ASTM C-171		
Part No.	Description	sf/roll
SBSCSOG1600	Slab on grade, flatwork, retail, industrial, tilt-up	1600



## Curing Chemicals

Full line of flooring chemicals & joint fillers

<b>Hydrate</b>		
Product	Description	Package
SureFilm	Evaporation Retarder / Finishing Aid (Concentrate)	5 gal, 55 gal
SureCure	ASTM C 309 Modified Cure (Steel Trowel)	5 gal, 55 gal
SureRez	ASTM C 309 Dissipating Resin	5 gal, 55 gal
SureCure & Seal WB	ASTM C 309, Water-Based, Acrylic Curing Compound	5 gal, 55 gal
SureCure & Seal 25	ASTM C 309, Solvent-Based, Acrylic Curing Compound	5 gal, 55 gal

refer to full data sheets online

## Tilt-Up Profiles

Detailed lines, chamfered edges and smooth reveals for a better concrete appearance

<b>Saw Cut Cover</b> A semi-rigid, plastic t-strip used to seal concrete saw cut joints before pouring tilt-up panels.			
Part No.	Description	lf/bundle	
SBSCC2	Cover Strip 3/8" Top x 5/8" Deep x 8'	1000	

## Protecting Concrete

Increase abrasion resistance and protect saw cut joints

### SureSeal Li

An economical lithium-silicate sealer/densifier that deeply penetrates and reacts with cured concrete to reduce porosity, reduce dusting, reduce water permeability and increase abrasion resistance. When properly applied, SureSeal Li will not leave the whitish blush characteristic of other sodium silicate products.

- Reduce application costs with one step low pressure spray application on broom or power troweled finishes.
- Achieve architectural finishes, does not contribute to Alkali Surface Reaction (ASR)
- Can be used interior and exterior.
- Fast-curing. Ready for traffic in one hour for most floors
- Apply on new or existing concrete Improves abrasion resistance, light reflectivity and gloss



### SureFlex CJ

A 100% solids, two-component, UV resistant, semirigid, rapid-curing, polyurea for filling control and construction joints in heavy duty industrial concrete floors. SureFlex CJ allows for joints to be shaved quickly for fast turnaround. SureFlex CJ has been designed for use in compliance with ACI 302, section 4.10 recommendations for joint fillers used in saw cut/control joints with a Shore A Durometer of 85. SureFlex CJ can also be used for the repair of damaged or spalled joint nosing and cracks.

- Easy 1 to 1 ratio, pourable/pumpable consistency
- High elongation (200%) to resist tearing due to excessive movement
- Industrial & Commercial Floors
- Control & Construction Joints
- Crack & Joint repair

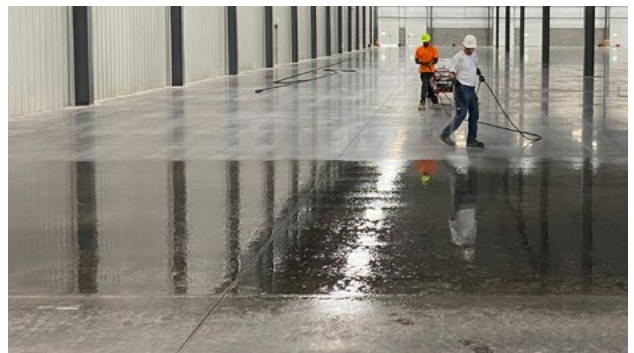

## Protect

Product	Description	Package
SureSeal Li	Lithium Silicate Sealer / Densifier	5 gal, 55 gal
SureSeal So	Sodium Silicate Sealer / Densifier	5 gal, 55 gal
Citrus Cleaner	Natural Citrus Solvent Floor Cleaner	5 gal, 55 gal
SureFlex CJ	Semi-Rigid, Rapid Curing, UV Resistant, Polyurea, 100% Solids, two component	10 gal
SureFlex CJ Guard	Prevents or reduces staining of concrete due to overfill of epoxy or polyurea joint fillers	5 gal, 55 gal

refer to full data sheets online

### **Articulated Waler**

Radius forming from 20' to 180', with 3/4" plywood, aluminum or wood beams, and an adjustable waler.

### **Bar Support**

Wire slab bolsters and high chairs, with optional epoxy-coat, plastic-dip, plastic-tip or plate, to meet almost any slab requirement.

### **Bridge Deck**

Overhang brackets and hangers provide an efficient deck forming solution for precast concrete or steel I-beam bridge structures.

### **Coil Ties**

2-Strut and 4-Strut designs, in standard and heavy-duty capacities, with optional cones, waterseals or custom combination, for job-built forming.

### **Euro Rod**

15mm and 20mm taper ties, she-bolts, inner ties, washers and wing nuts compatible with European-brand forming systems.

### **Floor Dowels**

Plates, sleeves, baskets and joint nosings for high-performance concrete floors.

### **Pipe Braces**

Contractor-preferred braces, with rated capacities and lengths ranging from 7'6" to 62'6", for almost any forming application.

### **Precast**

Inserts, anchors, connectors and lifting systems for efficient precast concrete production.

### **Self-Riser**

Integrated hydraulic system for multi-story building cores that virtually eliminates crane time.

### **Shoring**

A conventional 12K load/leg system, with base plates, cross braces, screw jacks and U-heads, for productive deck support.

### **Snap Ties**

Ties and brackets, with 3/4" plywood and 2x4 lumber, create a simple and effective plywood forming system.

### **Staybox**

A pre-engineered and pre-assembled rebar keyway that simplifies forming at wall and deck intersections.

### **Stud Rail**

A reinforced column-to-deck connection that reduces shearing, transfers load further into the slab and eliminates column capitals.

### **SureCurve™ RC**

Concrete tanks and curved walls quickly take shape with this flexible gangform system.

### **SurePly™**

An industry-recognized handset system, with more than 80 standard panel and filler sizes, for almost any forming application.

### **Tilt-Up**

A start-to-finish system of lifting inserts, plates and hardware for tilt-up panel construction.

### **Walers**

Double channel walers align panels, carry taper tie loads and maximize the surface area of almost any gang.