

FluoroSeal Inc.



**LINED PLUG VALVES**

# LINED PLUG VALVES CATALOGUE

## TABLE OF CONTENTS

|   | Page |
|---|------|
| Design Features                         | A1   |
| Components                              | A3   |
| Options                                 | B1   |
| EZ-SEAL® Option                         | B2   |
| Other Options                           | B4   |
| Accessories                             | C1   |
| Stem Extension — Lever Operator         | C2   |
| Stem Extension — Gear Operator          | C2   |
| Handwheel Extension — Gear Operator     | C2   |
| T-Wrench and Extension Option           | C3   |
| Crank Handle                            | C3   |
| Chain Wrench                            | C3   |
| Chain Wheel                             | C3   |
| Locking Devices                         | C4   |
| Technical Data                          | D1   |
| Lined Plug Valves Ordering Instructions | E1   |
| Terms & Conditions                      | F1   |

**PRECISION CAST BODY, PLUG AND COVER**

All FluoroSeal® Lined Plug Valves major pressure-bearing components are produced by investment casting, ensuring tight tolerance control and superior surface finish.

- All casting components traceable to mill test certificates
- Investment casting of all materials for sizes 1/2" – 10" (ANSI/ASME Class 150 lbs)
- Investment casting of all materials for sizes 1/2" – 6" (ANSI/ASME Class 300 lbs)
- Investment casting of all materials for sizes DN 15 – DN 150 (PN 16 – PN 40)

**CORROSION PROTECTION**

FluoroSeal® standard base model offers Carbon Steel body, plug and cover (ASTM A216 Gr. WCB, 1.0619). Even though FluoroSeal Inc. offers the low porosity PFA (Perfluoroalkoxy) as standard, all cast parts have an epoxy-based coating prior to lining for added protection from corrosion attack due to permeation.

**LOCKED -IN LINER**

Lined Plug Valves feature a virgin, unpigmented PFA lining applied by Transfer Molding and locked onto the castings with machined or cast dovetail-shaped grooves and anchoring holes. This helps prevent liner collapse in vacuum in vacuum applications, and blow-out in applications with a combination of high pressure/high temperature.

The Transfer Molding method ensures equal distribution and consistency of liner throughout the entire surface of the lined components. FluoroSeal® Lined Plug Valves comply with the industry specifications (ASTM F1545) dictating the liners' uniform thickness across the entire valve and guarantee the absence of any weak section in the valve liner. Absence of pigmentation in the PFA renders all defects visible and testifies to FluoroSeal Inc.'s commitment of quality first.

The use of virgin PFA reduces stress in the lining which could result from the use of regrind in its composition.

**CAVITY-FREE DESIGN**

By design, Plug Valves are cavity-free both in open and closed positions. This prevents the accumulation of particles between the plug and body and makes the valve ideal for corrosive slurry applications.



Lined Plug Cutaway

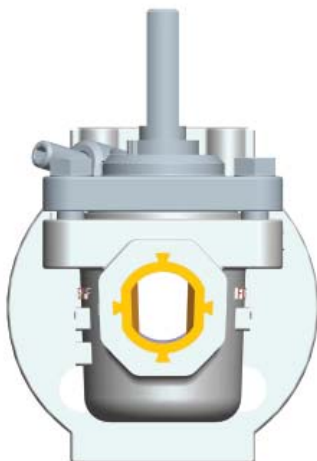

Dovetail Liner Section  
Pictured with EZ-SEAL® Cover  
(Optional)

PLUG-LINED-R001-2013

## LARGE SEALING AREA

The interface between the tapered outer plug and the tapered inner body liner provides a 360° sealing area. This results in a tight shutoff. The seal is created due to compression between the plug and body, thus the valve is bidirectional and seals on both upstream and downstream sides simultaneously.

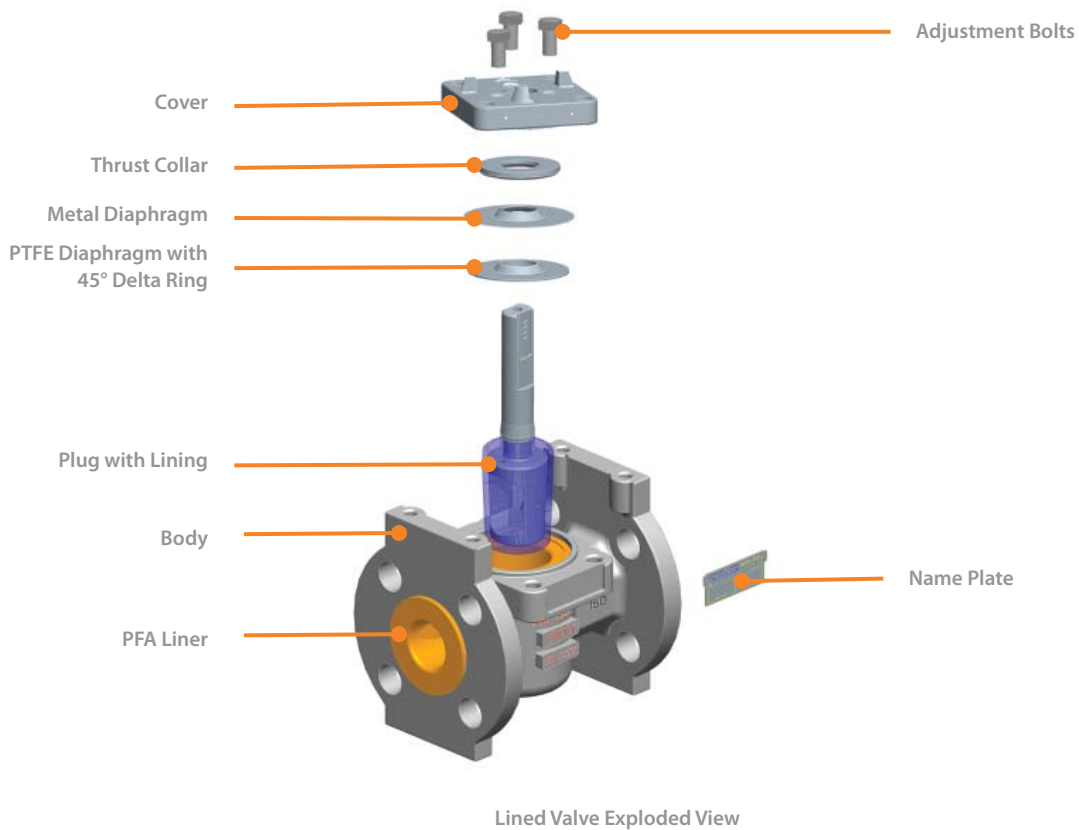

Full Port, Multi-Port, and Severe Service Lined Plug Valves are available upon request only.



Class 150 Lbs FluoroSeal® Lined Plug Valve, Bare Stem

**MATERIALS OF CONSTRUCTION**

|                                     |                                      |
|-------------------------------------|--------------------------------------|
| Body and Plug <sup>1</sup>          | As Specified                         |
| Cover <sup>2</sup>                  | Carbon Steel or 304 SS               |
| Cover Bolts <sup>2</sup>            | Carbon Steel or 304 SS               |
| Adjusting Bolts                     | 304 SS                               |
| Thrust Washer                       | 304 SS                               |
| Metal Diaphragm                     | 304 SS                               |
| Delta Ring                          | PTFE Fluorocarbon                    |
| Diaphragm                           | PTFE Fluorocarbon                    |
| Lining (Body and Plug) <sup>3</sup> | As Specified                         |
| Wrench Operator                     | Carbon Steel                         |
| Wrench Bolt                         | Steel                                |
| Gear Assembly                       | Heavy Duty Cast Carbon Steel Housing |
| Gear Adaptor                        | Hi-Strength Steel                    |
| Gear Mounting Bracket               | 304 SS                               |
| Mounting Bracket Bolts              | Steel                                |

1. See BODY & PLUGS MATERIAL TABLE for material selections.
2. Cover and bolt materials of standard valves will be supplied in accordance with the following table:

| SPECIFIED BODY      | COVER        | ANSI/ASME COVER BOLT | DIN COVER BOLT |
|---------------------|--------------|----------------------|----------------|
| Ductile Iron        | Carbon Steel | ASTM A193 Gr. B7     | DIN EN 10269   |
| Carbon Steel        | Carbon Steel | ASTM A193 Gr. B7     | DIN EN 10269   |
| All Other Materials | CF8          | ASTM A193 Gr. B8     | DIN EN 10269   |

Covers can be delivered in the same material as body if specified at time of order.

3. See BODY & PLUGS MATERIAL TABLE for lining material selection.

PLUG-LINED-R001-2013

# LINED PLUG VALVES

## LINED ANSI/ASME CLASS 150 LBS

Flanged Ends

Wrench or Enclosed Gear Operated

Actuators Optional on All Sizes

Dimensions to ANSI B16.5 & B16.10

EG = Enclosed gear operated

N = Number of holes

Two (2) top holes in flanges are tapped with UNC threads. See Hole-UNC column

\* Available upon request

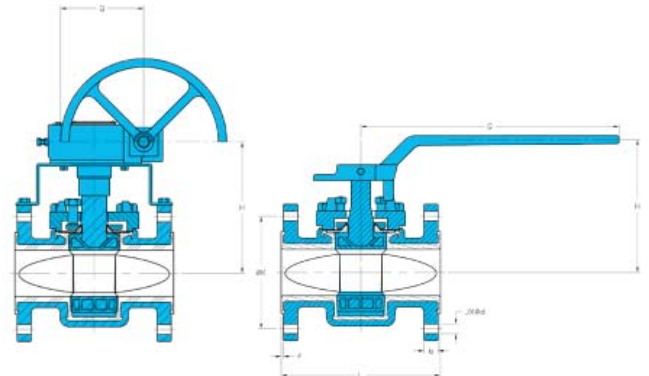

| SIZE & PRODUCT DESCRIPTION | L     |        | H     |        | D     |        | K     |        | g     |        | b    |       | f    |      | d    |       | Q     |        | N  | Hole-UNC |
|----------------------------|-------|--------|-------|--------|-------|--------|-------|--------|-------|--------|------|-------|------|------|------|-------|-------|--------|----|----------|
|                            | in    | mm     | in    | mm     | in    | mm     | in    | mm     | in    | mm     | in   | mm    | in   | mm   | in   | mm    | in    | mm     | #  |          |
| 1/2" LR152F/W-WCB/PFA      | 4.33  | 109.98 | 3.70  | 93.98  | 3.50  | 88.90  | 2.38  | 60.45  | 1.38  | 35.05  | 0.31 | 7.87  | 0.06 | 1.52 | 0.63 | 16.00 | 8.00  | 203.00 | 4  | -        |
| 3/4" LR152F/W-WCB/PFA      | 4.69  | 119.13 | 3.70  | 93.98  | 3.88  | 98.55  | 2.75  | 69.85  | 1.69  | 42.93  | 0.34 | 8.64  | 0.06 | 1.52 | 0.63 | 16.00 | 8.00  | 203.00 | 4  | -        |
| 1" LR152F/W-WCB/PFA        | 5.00  | 127.00 | 4.40  | 111.76 | 4.25  | 108.00 | 3.13  | 79.50  | 2.00  | 50.80  | 0.38 | 9.65  | 0.06 | 1.52 | 0.63 | 16.00 | 9.00  | 229.00 | 4  | -        |
| 1 1/2" LR152F/W-WCB/PFA    | 6.50  | 165.10 | 5.20  | 132.08 | 5.00  | 127.00 | 3.88  | 98.60  | 2.88  | 73.20  | 0.50 | 12.70 | 0.06 | 1.52 | 0.63 | 16.00 | 14.25 | 362.00 | 4  | -        |
| 2" LR152F/W-WCB/PFA        | 7.00  | 177.80 | 6.00  | 152.40 | 6.00  | 152.40 | 4.75  | 120.70 | 3.63  | 92.00  | 0.56 | 14.22 | 0.06 | 1.52 | 0.75 | 19.00 | 16.50 | 419.00 | 4  | -        |
| 3" LR152F/W-WCB/PFA        | 8.00  | 203.20 | 6.60  | 167.64 | 7.50  | 190.50 | 6.00  | 152.40 | 5.00  | 127.00 | 0.69 | 17.53 | 0.06 | 1.52 | 0.75 | 19.00 | 16.50 | 419.00 | 4  | -        |
| 4" LR152F/W-WCB/PFA        | 9.00  | 228.60 | 7.80  | 198.12 | 9.00  | 228.60 | 7.50  | 190.50 | 6.19  | 157.20 | 0.88 | 22.40 | 0.06 | 1.52 | 0.75 | 19.00 | 23.60 | 599.44 | 8  | -        |
| 4" LR152F/EG-WCB/PFA       | 9.00  | 228.60 | 9.00  | 228.60 | 9.00  | 228.60 | 7.50  | 190.50 | 6.19  | 157.20 | 0.88 | 22.40 | 0.06 | 1.52 | 0.75 | 19.00 | 7.25  | 184.00 | 8  | -        |
| 6" LR152F/EG-WCB/PFA       | 10.50 | 266.70 | 10.70 | 271.78 | 11.00 | 279.40 | 9.50  | 241.30 | 8.50  | 215.90 | 0.94 | 23.88 | 0.06 | 1.52 | 0.88 | 22.40 | 7.25  | 184.00 | 8  | -        |
| 8" LR152F/EG-WCB/PFA*      | 11.50 | 292.10 | 13.00 | 330.20 | 13.50 | 342.90 | 11.75 | 298.50 | 10.63 | 269.80 | 1.06 | 26.92 | 0.14 | 3.56 | 0.88 | 22.40 | 9.75  | 248.00 | 8  | 3/4"-10  |
| 10" LR152F/EG-WCB/PFA*     | 13.00 | 330.20 | 14.90 | 378.46 | 16.00 | 406.40 | 14.25 | 362.00 | 12.75 | 323.90 | 1.12 | 28.45 | 0.14 | 3.56 | 1.00 | 25.40 | 9.75  | 248.00 | 12 | 7/8"-9   |
| 12" LR152F/EG-WCB/PFA*     | 14.00 | 355.60 | 15.70 | 398.78 | 19.00 | 482.60 | 17.00 | 431.80 | 15.00 | 381.00 | 1.19 | 30.23 | 0.14 | 3.56 | 1.00 | 25.40 | 13.75 | 349.25 | 12 | 7/8"-9   |
| 14" LR152F/EG-WCB/PFA*     | 15.00 | 381.00 | 15.70 | 398.78 | 21.00 | 533.40 | 18.75 | 476.30 | 16.25 | 412.80 | 1.31 | 33.27 | 0.14 | 3.56 | 1.12 | 28.40 | 13.75 | 349.25 | 12 | 1"-8     |

## LINED ANSI/ASME CLASS 300 LBS

Flanged Ends

Wrench or Enclosed Gear Operated

Actuators Optional on All Sizes

Dimensions to ANSI B16.5 & B16.10

EG = Enclosed gear operated

N = Number of holes

Two (2) top holes in flanges are tapped with UNC threads. See Hole-UNC column

\* Available upon request

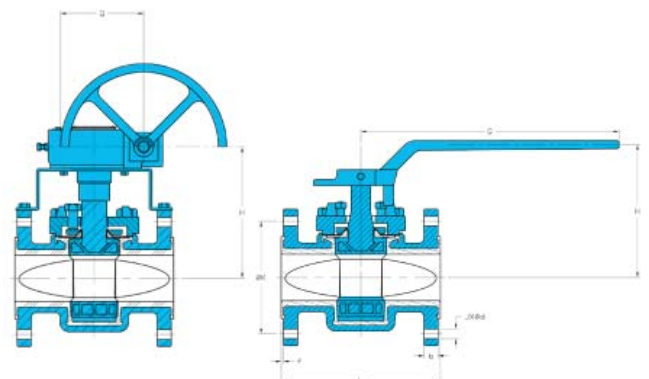

| SIZE & PRODUCT DESCRIPTION | L     |        | H     |        | D     |        | K     |        | g    |        | b    |       | f    |      | d    |       | Q     |        | N  | Hole-UNC |
|----------------------------|-------|--------|-------|--------|-------|--------|-------|--------|------|--------|------|-------|------|------|------|-------|-------|--------|----|----------|
|                            | in    | mm     | in    | mm     | in    | mm     | in    | mm     | in   | mm     | in   | mm    | in   | mm   | in   | mm    | in    | mm     | #  |          |
| 1" LR302F/W-WCB/PFA        | 6.54  | 166.12 | 4.40  | 110.74 | 4.88  | 123.95 | 3.50  | 88.90  | 2.00 | 50.80  | 0.62 | 15.75 | 0.04 | 1.02 | 0.75 | 19.05 | 9.00  | 228.60 | 4  | -        |
| 1 1/2" LR302F/W-WCB/PFA    | 7.54  | 191.52 | 5.20  | 132.91 | 6.12  | 155.45 | 4.50  | 114.30 | 2.88 | 73.15  | 0.75 | 19.05 | 0.04 | 1.02 | 0.88 | 22.23 | 14.30 | 361.95 | 4  | -        |
| 2" LR302F/W-WCB/PFA        | 8.54  | 216.92 | 6.00  | 151.85 | 6.50  | 165.10 | 5.00  | 127.00 | 3.62 | 91.95  | 0.81 | 20.57 | 0.04 | 1.02 | 0.75 | 19.05 | 16.50 | 419.10 | 8  | -        |
| 3" LR302F/W-WCB/PFA        | 11.14 | 282.96 | 6.60  | 166.43 | 8.25  | 209.55 | 6.62  | 168.15 | 5.00 | 127.00 | 1.06 | 26.92 | 0.04 | 1.02 | 0.88 | 22.23 | 16.50 | 419.10 | 8  | -        |
| 4" LR302F/W-WCB/PFA        | 12.04 | 305.82 | 7.80  | 197.31 | 10.00 | 254.00 | 7.88  | 200.15 | 6.19 | 157.23 | 1.19 | 30.23 | 0.06 | 1.52 | 0.88 | 22.23 | 23.60 | 600.08 | 8  | -        |
| 4" LR302F/EG-WCB/PFA       | 12.04 | 305.82 | 9.00  | 229.08 | 10.00 | 254.00 | 7.88  | 200.15 | 6.19 | 157.23 | 1.19 | 30.23 | 0.06 | 1.52 | 0.88 | 22.23 | 7.30  | 184.15 | 8  | -        |
| 6" LR302F/EG-WCB/PFA       | 15.92 | 404.37 | 10.70 | 272.26 | 12.50 | 317.50 | 10.62 | 269.75 | 8.50 | 215.90 | 1.38 | 35.05 | 0.06 | 1.52 | 0.88 | 22.23 | 7.30  | 184.15 | 12 | -        |

# FluoroSeal Inc.

Specialty Valves



OPTIONS

## LINED PLUG VALVES — EZ SEAL® OPTION



### EZ-SEAL® TOP SEAL & ADJUSTMENT SYSTEM

This innovation places FluoroSeal® Plug Valves at the leading edge of technology in the industrial valve market .

FluoroSeal® Lined Plug Valves can be equipped with the state-of-the-art EZ-SEAL® (patented) adjustment mechanism, available on sizes 1/2" to 6" (DN 15 to DN 150).

The EZ-SEAL® offers 360° simultaneous and even compression adjustment of the packing and plug, eliminating side loading. Visual indication takes the guess work out of valve adjustment and remaining service life diagnostic.

### THE EZ-SEAL® CONCEPT

An easily accessible, single point frontal adjustment system that introduces the ease and precision of maintenance planning and cost savings on both manual and automated valve applications. Achievement is two-fold:

1. Maintenance technicians now have a trouble-free way of resealing both manual and automated valves with a single, quick and easy adjustment point (in comparison to time-consuming, cumbersome multiple adjustment bolt designs) — no special tooling needed
2. Visual gauging offers up-front knowledge of valve status, useful in scheduling valve change-out on shutdowns

### DESIGN FEATURES SUMMARY

1. Single point frontal adjustment system
2. 360° simultaneous and even compression of top seal and plug
3. Plug adjustment is linear, impossible to side load
4. Tapered stem for increased sealing capabilities
5. Visual Min / Max cam adjustment indicator
6. Combination formed metal diaphragm and static eliminator
7. ISO mount stem
8. All-in-one ISO bracket and locking device, as standard
9. All components are high precision investment cast
10. Explosion-proof stem design
11. Positive shutoff



EZ-SEAL® (Patented)  
Bracket and Lock

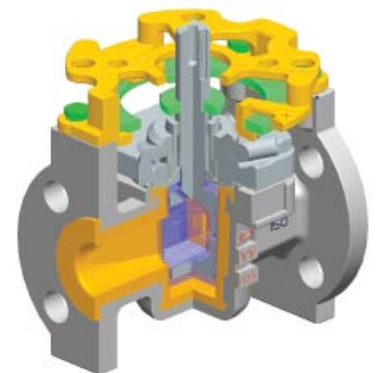

Lined Valve Section View  
Pictured with EZ-SEAL® Cover  
(Optional)

PLUG-LINED-R001-2013



QUADRUPLE ATMOSPHERIC SEAL WITH EZ-SEAL®

Single point external adjusting bolt (patented) in the EZ-SEAL® optional cover ensures equilibrium to the compression of the stem and in-line seals by imparting a balanced force through a metal thrust cam inserted in the cover above the formed metal diaphragm. This system provides a definitive advantage over other adjustment methods available on the market by eliminating all side loading and related wear-and-tear on the liner.

The primary seal of the plug valve is between the plug and body liner. The additional sealing levels are an integrated delta ring and PTFE diaphragm completely encapsulated by a metal diaphragm. The delta ring and PTFE diaphragm have a double role of plug and stem seal. The specially formed metal diaphragm assists in encapsulation, acts as an antistatic device, and is a metal seal to atmosphere, in case of PTFE failure. The combined mechanism provides an excellent, quadruple seal to atmosphere and in-line seal adjustment.

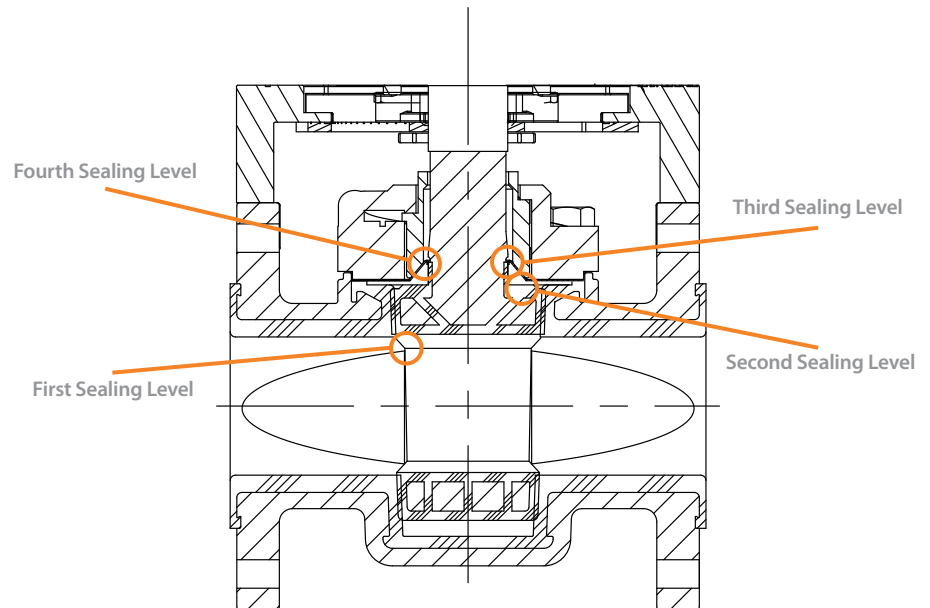

## LINED PLUG VALVES — OTHER OPTIONS

### CHLORINE SERVICE

FluoroSeal® Plug Valves are manufactured in accordance with the recommendations of the Chlorine Institute Pamphlet 6 and provide superior performance in this demanding application. All FluoroSeal® Chlorine Valves are made from thoroughly cleaned and dried components under controlled conditions and this control is maintained throughout parts preparation, assembly, testing, and special protective packaging. Other customer requirements can be incorporated upon request, provided that they conform to the specifications of Pamphlet 6.

FluoroSeal® Lined Chlorine Service Valves can be provided with the optional vented plug to relieve pressure to the upstream side. This modification results in a uni-directional valve which is indicated on the valve with a flow direction arrow.

### V-PORT & CHARACTERIZED PLUGS

FluoroSeal® Plug Valves are also available with Characterized Plugs for fine control applications. Standard V-Ports in 60° and other custom configurations are available in all trim materials.

The design and features of the FluoroSeal® Plug Valve makes it an excellent choice for fine throttling in slurry and chemical applications. The no-cavity design allows the plug valve to throttle without exposing the stem seal to line pressure, a definite advantage over most ball valves specifically in high cycling applications.



Chlorine Service Packaging Caution Tags



V-Port Lined Plug

# FluoroSeal Inc.

Specialty Valves

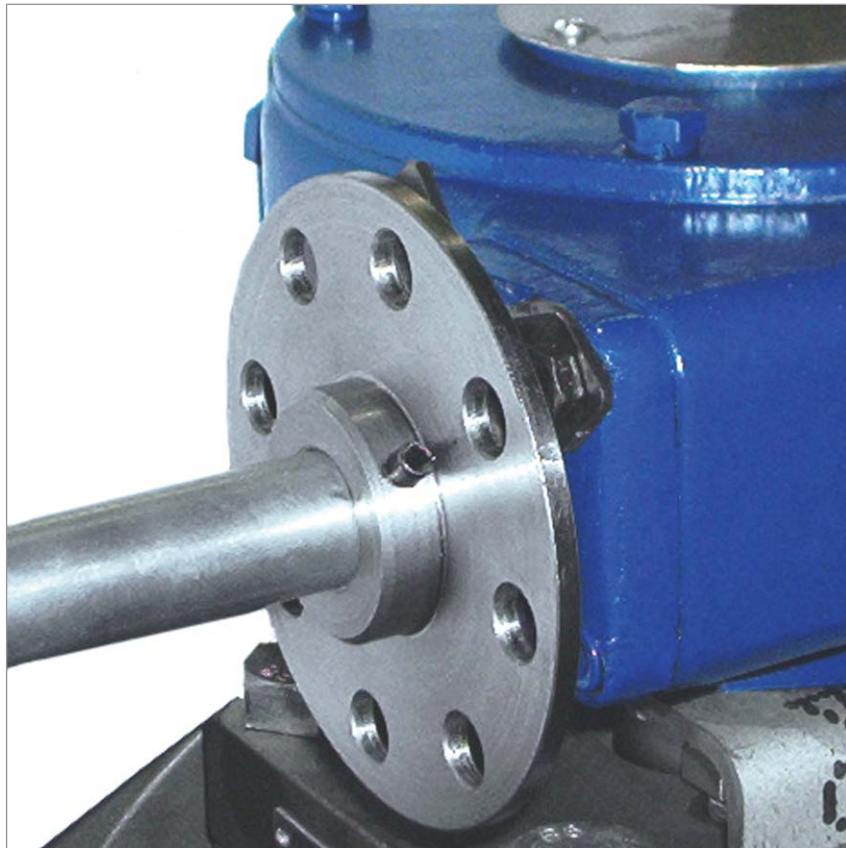

## ACCESSORIES

## ACCESSORIES

### STEM EXTENSION — LEVER OPERATOR

Stem extensions are used for remote operation of the valve. A fixed length of 4" is standard for a stem extension on a lever operated lined valve. Not available on the EZ-SEAL® option (bracket supplied with valve should provide adequate space for insulation). Other lengths available upon request.

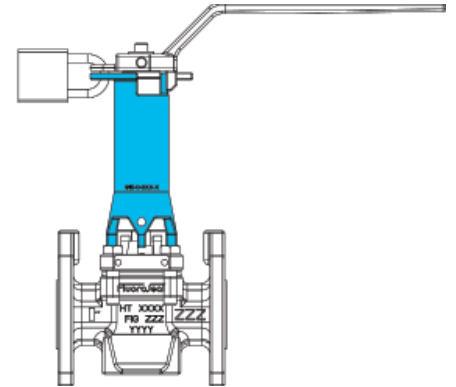

### STEM EXTENSION — GEAR OPERATOR

Stem extensions are used for remote operation of the valve. Actuators can be attached to the top of the extension. Specify the length (L) of the extension required and the figure number of the valve it is to be attached to. Not available on the EZ-SEAL® option.

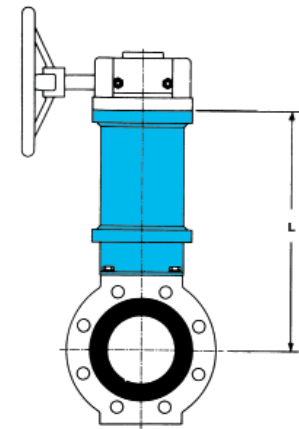

### HANDWHEEL EXTENSION — GEAR OPERATOR

Custom extension to fit your particular space requirements. Please specify the length (L) needed. Support may be required depending on the length of the extension. (To be supplied by the customer.)

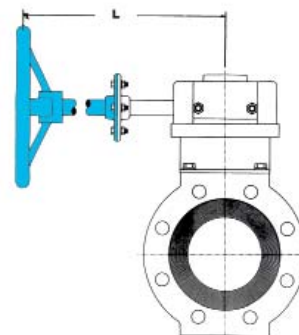

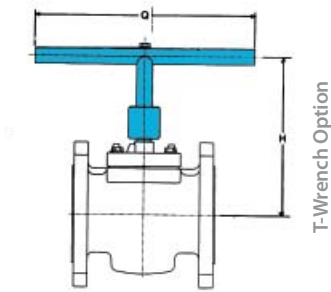

**T-WRENCH AND EXTENSION OPTION**

If longer "H" dimension, please specify.

| VALVE SIZE | 1/2" (DN 15) |        | 3/4" (DN 20) |        | 1" (DN 25) |        | 1 1/2" (DN 40) |        | 2" (DN 50) |        | 3" (DN 80) |        | 4" (DN 100) |         |
|------------|--------------|--------|--------------|--------|------------|--------|----------------|--------|------------|--------|------------|--------|-------------|---------|
|            | in           | mm     | in           | mm     | in         | mm     | in             | mm     | in         | mm     | in         | mm     | in          | mm      |
| Q          | 12.00        | 304.80 | 12.00        | 304.80 | 18.00      | 457.20 | 28.00          | 711.20 | 36.00      | 914.40 | 36.00      | 914.40 | 42.00       | 1066.80 |
| H          | 6.80         | 172.72 | 6.80         | 172.72 | 7.40       | 187.96 | 8.00           | 203.20 | 8.40       | 213.36 | 9.00       | 228.60 | 9.60        | 243.84  |

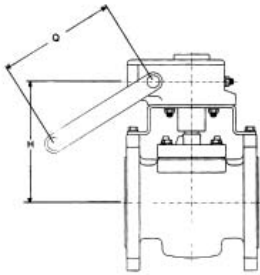

**CRANK HANDLE**

| VALVE SIZE | 4" EG (DN 100) |        | 6" EG (DN 150) |        | 8" EG |        | 10" EG |        | 12" EG |        |
|------------|----------------|--------|----------------|--------|-------|--------|--------|--------|--------|--------|
|            | in             | mm     | in             | mm     | in    | mm     | in     | mm     | in     | mm     |
| Q          | 7.25           | 184.15 | 7.25           | 184.15 | 9.75  | 247.65 | 9.75   | 247.65 | 13.75  | 349.25 |
| H          | 10.75          | 273.05 | 11.50          | 292.10 | 13.00 | 330.20 | 15.50  | 393.70 | 17.25  | 438.15 |

**CHAIN WRENCH**

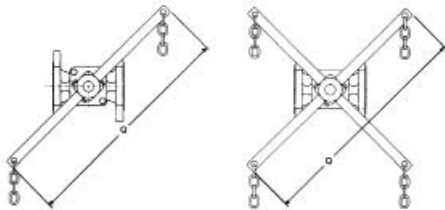

Specify the chain length required and whether the valve will be installed in a horizontal or vertical line. To calculate chain length:

- 90° rotation: 1. Double required drop  
 2. Multiply Q by 0.5  
 3. 1+2 = required chain length
- 180° rotation: Double calculation for 90°

| VALVE SIZE | 1/2" (DN 15) |        | 3/4" (DN 20) |        | 1" (DN 25) |        | 1 1/2" (DN 40) |        | 2" (DN 50) |        | 3" (DN 80) |        | 4" (DN 100) |         |
|------------|--------------|--------|--------------|--------|------------|--------|----------------|--------|------------|--------|------------|--------|-------------|---------|
|            | in           | mm     | in           | mm     | in         | mm     | in             | mm     | in         | mm     | in         | mm     | in          | mm      |
| Q          | 13.00        | 330.20 | 13.00        | 330.20 | 16.00      | 406.40 | 24.00          | 406.40 | 36.00      | 914.40 | 36.00      | 914.40 | 60.00       | 1524.00 |

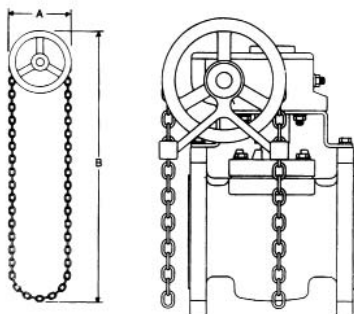

**CHAIN WHEEL**

Specify the chain length required and whether the valve will be installed in a horizontal or vertical line. To calculate chain length:

1. Double required drop B  
 2. Multiply chain wheel diameter A by 2.6  
 3. 1+2 = required chain length

PLUG-LINED-R001-2013

WRENCH OPERATOR LOCKING DEVICE

Padlock is not supplied. Locking device is included by default on the EZ-SEAL® option.

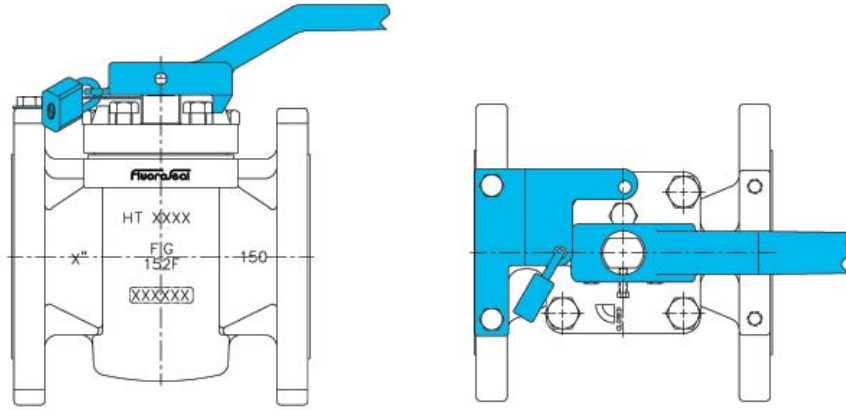

Locking Device on Regular Cover

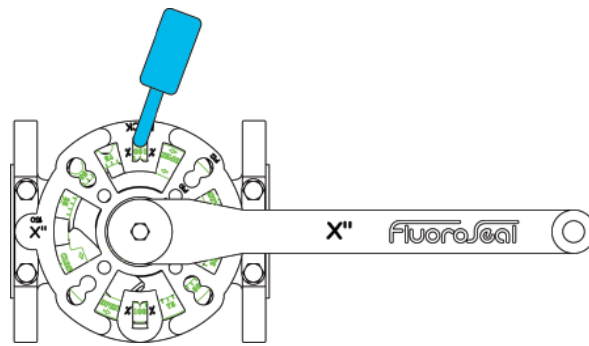

Locking Device on EZ-SEAL®

GEAR OPERATOR LOCKING DEVICE

Padlock is not supplied.

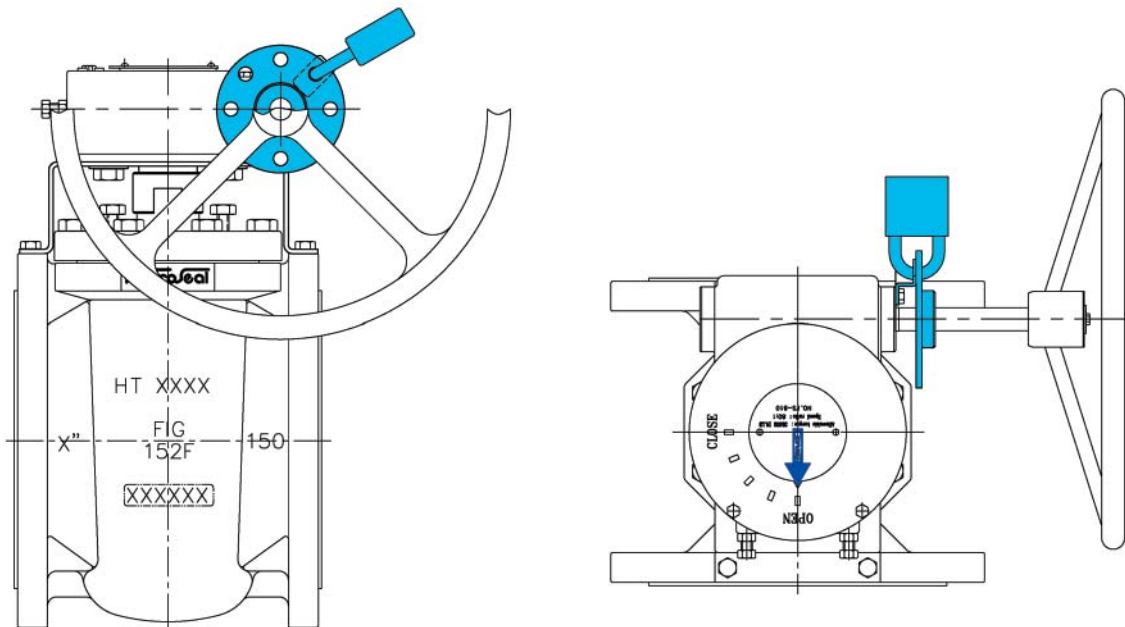

# FluoroSeal Inc.

Specialty Valves

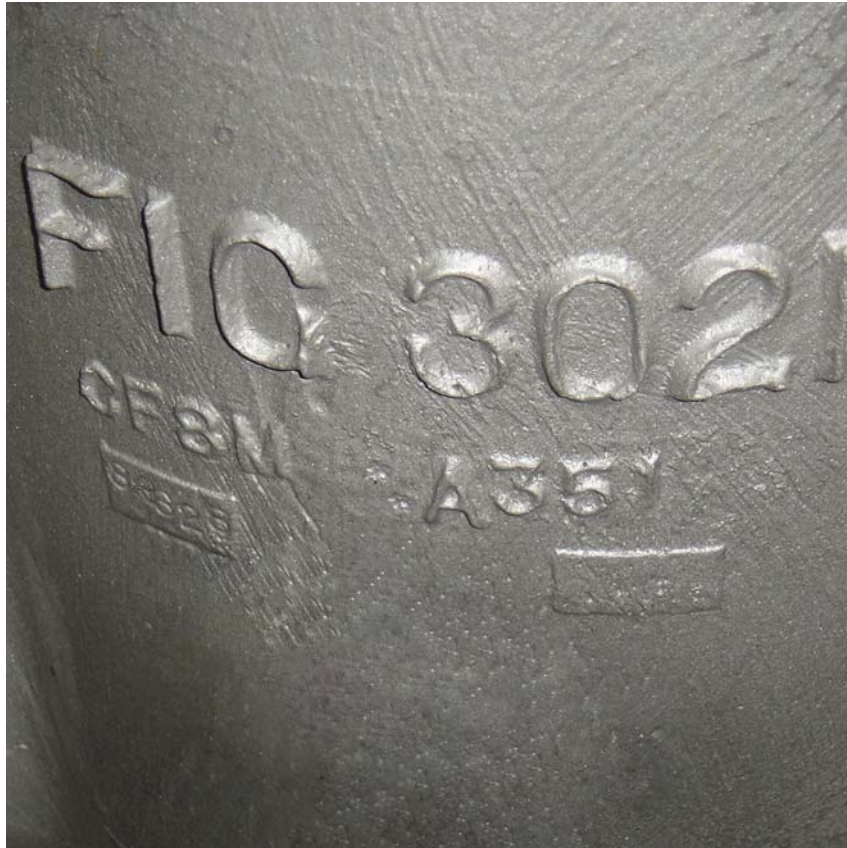

## TECHNICAL DATA

MATERIAL PROPERTIES

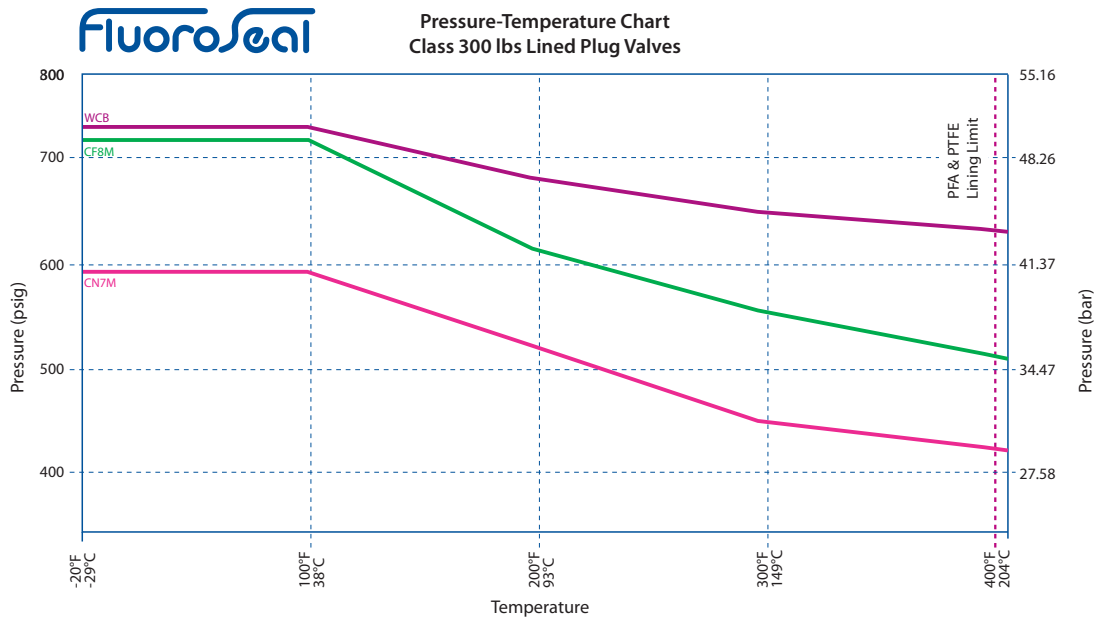
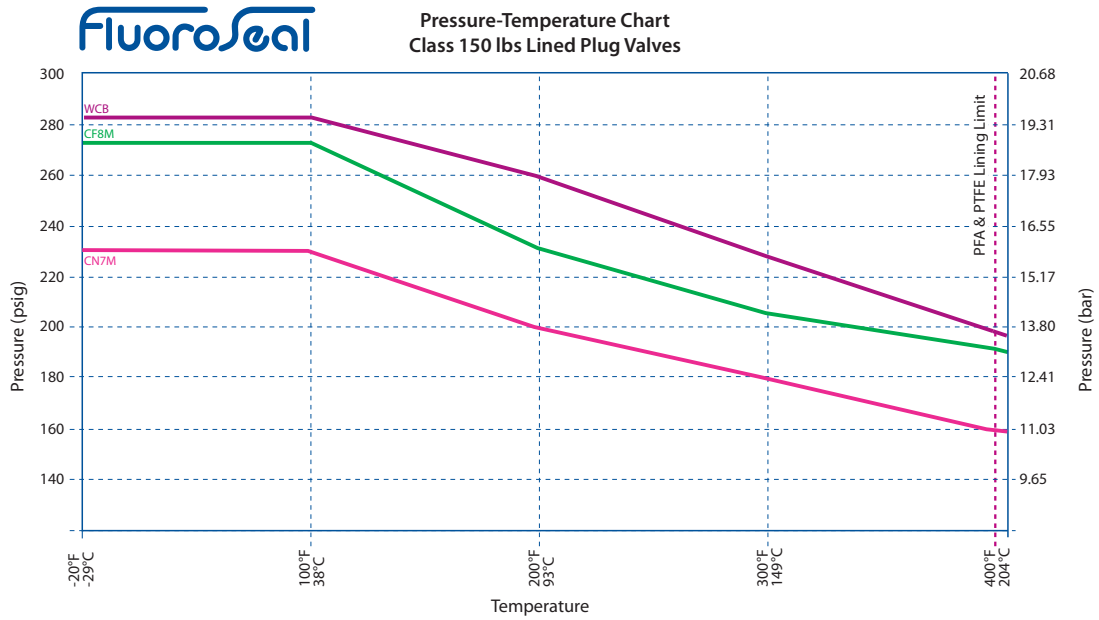



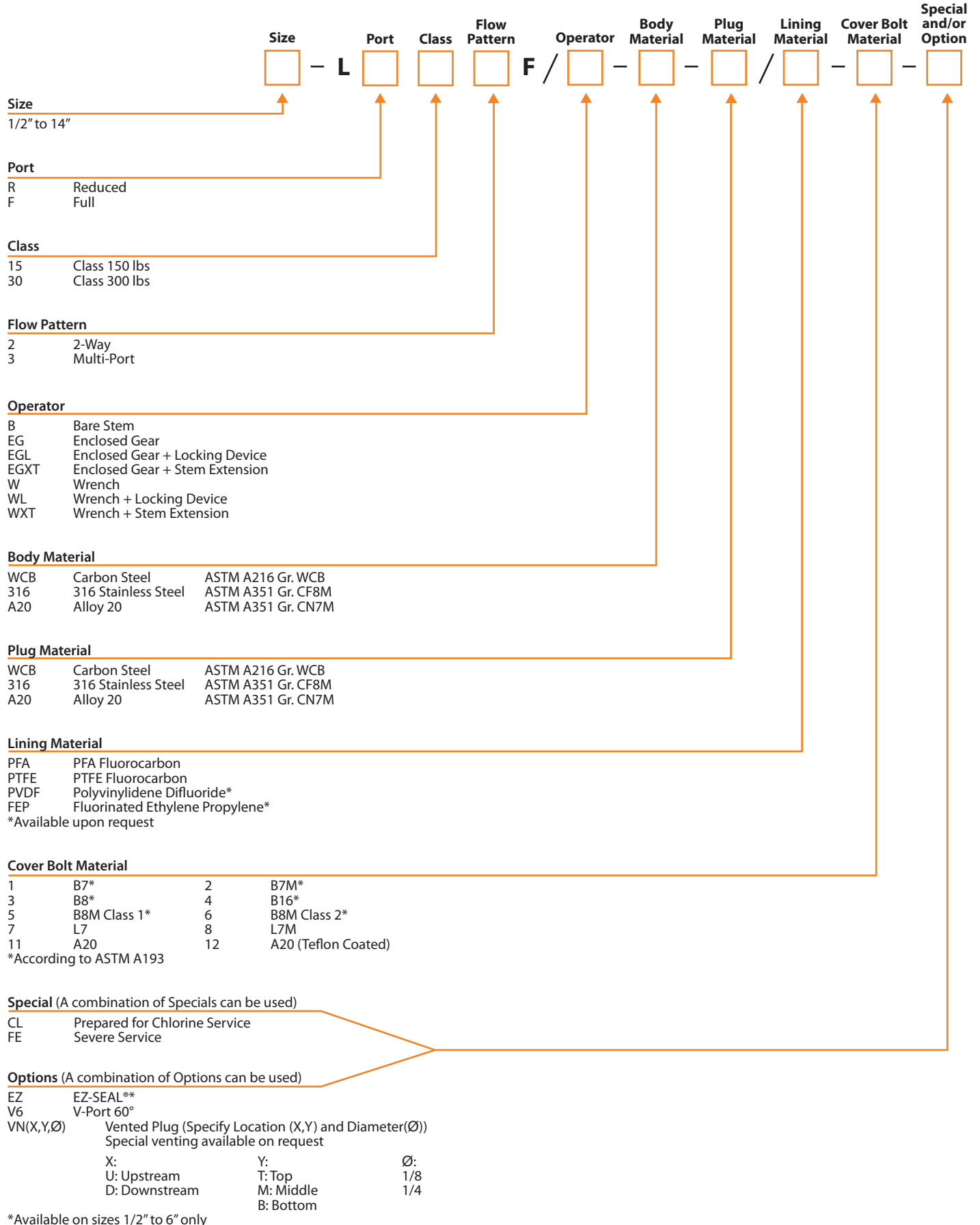

PLUG-LINED-R001-2013

# TERMS & CONDITIONS



## CONTROLLING PROVISIONS

These terms and conditions shall control with respect to any purchase order or sale of FluoroSeal Inc.'s products. No waiver, alteration or modification of these terms and conditions whether on Buyer's purchase order or otherwise, shall be valid unless the waiver, alteration or modification is specifically accepted in writing and signed by an authorized representative of FluoroSeal Inc.

**DELIVERY** FluoroSeal Inc. will make every effort to complete delivery of products as indicated on its acceptance of an order, but FluoroSeal Inc. assumes no responsibility or liability, and will accept no back charge, for loss or damage due to delay or inability to deliver caused by acts of God, war, labor difficulties, accident, delays of carriers, by contractors or suppliers, inability to obtain materials, shortages of fuel and energy, or any other causes of any kind whatever beyond the control of FluoroSeal Inc. FluoroSeal Inc. may terminate any contract of sale of its products without liability of any nature, by written notice to Buyer, in the event that the delay in delivery or performance resulting from any of the aforesaid causes shall continue for a period of sixty (60) days. Under no circumstances shall FluoroSeal Inc. be liable for any special or consequential damages or for loss, damage, or expense (whether or not based on negligence) directly or indirectly arising from delays or failure to give notice of delay.

**WARRANTY** FluoroSeal Inc. warrants for one year from the date of shipment of its manufactured products to the extent that FluoroSeal Inc. will replace those having defects in material or workmanship when used for the purpose and in the manner which FluoroSeal Inc. recommends. If FluoroSeal Inc.'s examination shall disclose to its satisfaction that the products are defective, and an adjustment is required, the amount of such adjustment shall not exceed the net sale price of the defective product(s) only and no allowance will be made for labor or expense for repairing or replacing defective products or workmanship or damage resulting from the same. FluoroSeal Inc. warrants the products which it sells of other manufacturers to the extent of the warranties of their respective makers. Where engineering design or fabrication work is supplied, Buyer's acceptance of FluoroSeal Inc.'s design or of delivery of work shall relieve FluoroSeal Inc. of all further obligation, other than expressed in FluoroSeal Inc.'s product warranty.

THIS IS FLUOROSEAL INC.'S SOLE WARRANTY. FLUOROSEAL INC. MAKES NO OTHER WARRANTY OF ANY KIND, EXPRESSED OR IMPLIED, AND ALL IMPLIED WARRANTIES OF MERCHANTABILITY AND FITNESS FOR A PARTICULAR PURPOSE WHICH EXCEED THE AFORE STATED OBLIGATION ARE HEREBY DISCLAIMED BY FLUOROSEAL INC. AND EXCLUDED FROM THIS WARRANTY.

FluoroSeal Inc. neither assumes, nor authorizes any person to assume for it, any other obligation in connection with the sale of its engineering designs or products. This warranty shall not apply to any products or parts of products which (a) have been repaired or altered outside of FluoroSeal Inc.'s factory, in any manner; (b) have been subjected to misuse, negligence or accidents; (c) have been used in a manner contrary to FluoroSeal Inc.'s instructions or recommendations. FluoroSeal Inc. shall not be responsible for design errors due to inaccurate or incomplete information supplied by Buyer or its representatives.

**LIABILITY** FluoroSeal Inc. will not be liable for any loss, damage, cost of repairs, incidental or consequential damages of any kind, whether based upon warranty (except for the obligation accepted by FluoroSeal Inc. under "Warranty" above), contract or negligence, arising in connection with the design, manufacture, sale, use or repair of the products or of

the engineering designs supplied to Buyer. Any litigation will be interpreted in accordance with the laws of the Province of Québec, Canada and any suit, action or proceeding relating to these terms and conditions may be instituted in any competent court sitting in the district of Montréal, Québec, Canada.

**RETURNS** FluoroSeal Inc. cannot accept return of any product(s) unless its written permission has been first obtained, in which case same will be credited subject to the following: (a) all material returned must, on its arrival at FluoroSeal Inc.'s plant, be found to be in first-class condition; if not, cost of putting in saleable condition will be deducted from credit memoranda; (b) a restocking charge will apply based on the nature of the product returned, and will be deducted from all credit memoranda issued for material returned; (c) transportation charges, if not prepaid, will be deducted from credit memoranda.

**SHIPMENTS** All products sent out will be carefully examined, counted and packed. The cost of any special packing or special handling caused by Buyer's requirements or requests shall be added to the amount of the order. No claim for shortages will be allowed unless made in writing within ten (10) days of receipt of a shipment. Claims for products damaged or lost in transit should be made to the carrier, as FluoroSeal Inc.'s responsibility ceases, and title passes, on delivery to the carrier.

**SPECIAL PRODUCTS** Orders covering special or non-standard products are not subject to cancellation except on such terms as FluoroSeal Inc. may specify on application.

**PRICES AND DESIGNS** Prices and designs are subject to change without notice. All prices are F.O.B. Point of Shipment, unless otherwise stated.

**TAXES** The amount of any sales, excise or other taxes, if any, applicable to the products, shall be added to the purchase price and shall be paid by Buyer unless Buyer provides FluoroSeal Inc. with an exemption certificate acceptable to the taxing authorities.

**NUCLEAR PLANTS** Where the products, engineering design or fabrication is for nuclear plant applications, Buyer agrees (a) to take all necessary steps to add FluoroSeal Inc. as an insured under the American Nuclear Insurers (ANI) pool and under the Mutual Atomic Energy Reinsurance Pool (MAERP) for property damage and liability insurance and if necessary steps could have been taken, but are not taken, Buyer shall hold FluoroSeal Inc. harmless against all such losses which could have been thus covered; (b) Buyer agrees to hold FluoroSeal Inc. harmless with respect to any personal injury or death, property damage or any other loss in a nuclear incident which is caused directly or indirectly by defective design, material, or workmanship, furnished by FluoroSeal Inc. and which is covered by insurance maintained by Buyer (or which could be so covered but with respect to which Buyer has elected to self-insure), and further agrees to waive subrogation by its carriers of such insurance against FluoroSeal Inc.; (c) as to nuclear hazards for which Buyer cannot obtain insurance coverage, the liability of FluoroSeal Inc. for any personal injury or death, property damage or any other loss directly caused by defective design, material, or workmanship furnished by FluoroSeal Inc. shall not exceed the value of the material furnished by FluoroSeal Inc. at the time of the loss occurrence.

**MINIMUM INVOICE** \$250 plus shipping.

**TERMS** Cash, net 30 days unless otherwise specified.

Most recent terms and conditions are available in the Downloads section of our website.

# FLUROSEAL INC. WORLDWIDE

## HEADQUARTERS

### FluroSeal Inc.

1875, 46e Avenue, Lachine, QC  
Canada H8T 2N8  
1 888 269 0220 (Canada and U.S.A.)  
T: (514) 739 0220  
F: (514) 739 5452  
[sales@fluorosealvalves.com](mailto:sales@fluorosealvalves.com)  
[www.fluorosealvalves.com](http://www.fluorosealvalves.com)

## CHINA

### FluroSeal Suzhou

1319 Jinfeng South Road  
Suzhou 215101, China  
T: 86 512 66389383  
F: 86 512 66569571  
[chinasales@fluorosealvalves.com](mailto:chinasales@fluorosealvalves.com)  
[www.fluorosealvalves.com](http://www.fluorosealvalves.com)

## EUROPE

### FluroSeal Europe GmbH

Künkelstr. 43 / Gebäude D5  
D-41063 Mönchengladbach, Germany  
T: 0049 2161 83905 70  
F: 0049 2161 83905 77  
[slange@fluorosealvalves.com](mailto:slange@fluorosealvalves.com)  
[www.fluorosealvalves.com](http://www.fluorosealvalves.com)

## U.S.A.

### FluroSeal U.S.A.

13350 South Gessner Rd.  
Missouri City, TX 77489  
T: (281) 741 7855  
F: (281) 741 3345  
[usasales@fluorosealvalves.com](mailto:usasales@fluorosealvalves.com)  
[www.fluorosealvalves.com](http://www.fluorosealvalves.com)

