



***FM 1-113**

Field Manual
No. 1-113

Headquarters
Department of the Army
Washington, DC, 25 June 1997

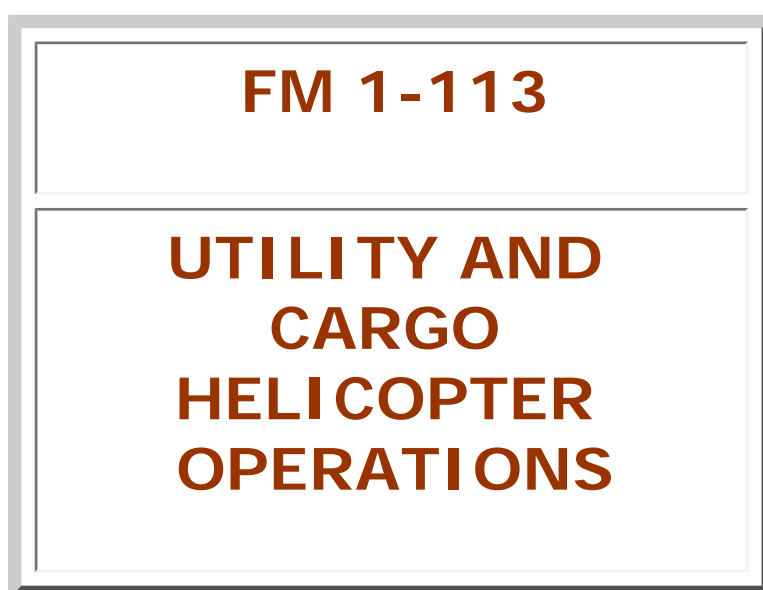

Table of Contents

[PREFACE](#)

[CHAPTER 1. UTILITY AND CARGO HELICOPTER FUNDAMENTALS](#)

[Doctrine Fundamentals](#)

[Utility and Cargo Helicopters in the Offense and Defense](#)

[Utility and Cargo Helicopter Unit organizations](#)

Capabilities and Limitations of Utility and Cargo Helicopters

CHAPTER 2. BATTLE COMMAND

Command and Control Duties and Responsibilities

Command Relationships

Support Relationships

Decision Making in the Utility and Cargo Helicopter Unit

Command Posts

Communications

CHAPTER 3. AIR ASSAULT OPERATIONS

General

Air Assaults in the Close, Deep, and Rear Fight

Capabilities and Limitations of Air Assault Forces

Air Assault Roles

Air Assault Task Force Key Personnel

Command and Control

Air Assault Planning Stages

Air Assault Planning

Air Assault Security

CHAPTER 4. AIR MOVEMENT OPERATIONS

General

[Utility and Cargo Helicopters in Air Movement Operations](#)

[Air Movement Planning Considerations](#)

[CHAPTER 5. COMMAND AND CONTROL OPERATIONS](#)

[General](#)

[Roles and Missions](#)

[Command and Control Configuration](#)

[Command and Control Mission Planning Considerations](#)

[CHAPTER 6. CASUALTY EVACUATION OPERATIONS](#)

[General](#)

[Levels of Care](#)

[Battlefield Casualty Evacuation Structure](#)

[Utility and Cargo Helicopter Casualty Evacuation Capabilities](#)

[Backhaul of Casualties During Air Assault Operations](#)

[Casualty Evacuation Mission Planning Considerations](#)

[CHAPTER 7. COMBAT SEARCH AND RESCUE](#)

[Combat Search and Rescue Functions](#)

[Combat Search and Rescue Imperatives](#)

[Combat Search and Rescue Operations](#)

[Combat Search and Rescue Mission Execution](#)

[Individual Combat Search and Rescue Preparation](#)

[CHAPTER 8. AERIAL MINE WARFARE \(VOLCANO\)](#)

[The Volcano Mine Dispensing System \(Description\)](#)

[Capabilities and Limitations](#)

[Employment Principles](#)

[Air Volcano in Combat Operations](#)

[Air Volcano Mission Execution](#)

[CHAPTER 9. STABILITY AND SUPPORT OPERATIONS](#)

[General](#)

[Operational Concept](#)

[Stability and Support Operations Principles](#)

[Stability and Support Operations Missions](#)

[Stability and Support Operations Planning Considerations](#)

[CHAPTER 10. COMBAT SERVICE SUPPORT](#)

[General](#)

[Planning](#)

[Fueling Operations](#)

[Maintenance and Recovery](#)

[Personnel Service Support](#)

[Ammunition](#)

APPENDIX A. UTILITY AND CARGO AIRCRAFT CHARACTERISTICS

APPENDIX B. INITIAL PLANNING CONFERENCE CHECKLIST

APPENDIX C. AIRCREW BRIEF

APPENDIX D. LIAISON OFFICER CHECKLIST AND BRIEF

APPENDIX E. FORWARD ARMING AND REFUELING POINT OPERATIONS

APPENDIX F. RISK MANAGEMENT/RISK ASSESSMENT

APPENDIX G. AIRCRAFT SURVIVABILITY

APPENDIX H. FLIGHT CREW MISSION BRIEF

APPENDIX I. ASSEMBLY AREA OPERATIONS

GLOSSARY

REFERENCES

AUTHENTICATION

DISTRIBUTION RESTRICTION: Approved for public release; distribution is unlimited.

This publication supersedes FM 1-113, 28 October 1986.



PREFACE

This manual describes how utility and cargo helicopter units plan and conduct a variety of combat, combat support, and combat service support missions. It provides doctrine for employing the utility and cargo helicopter unit on the modern battlefield. Appendix A provides aircraft characteristics and planning considerations for the use of utility and cargo aircraft. Appendixes B through D provide an example of a initial planning conference checklist, a aircrew briefing format, and a liaison officer checklist and a liaison officer briefing. Appendix E discusses the use of UH-60s and CH-47s for conducting FARP operations (Fat Hawk/Fat Cow). Appendixes F and G provide supplemental information for risk management and risk assessment and aircraft survivability. Appendix H provides a sample of a flight crew mission brief. Appendix I discusses assembly area operations for the utility and cargo helicopter unit. This manual is designed to act as an interim document for use by the current Army and will be updated as we move closer to the Force XXI Army. The TOE designed by the ARI serves as the basis for the units discussed. This publication is based on the doctrinal and tactical employment principles outlined in FMs [100-5](#), [1-100](#), [1-111](#), [100-15](#), and [100-20](#) and is a combination of the former FM 1-113 and TC 1-115.

This publication applies to commanders and staffs who will lead, employ, or fight with the utility and cargo helicopter units. It also serves as a reference document for flight crews learning to conduct various utility and/or cargo helicopter operations.

The proponent of this publication is HQ, TRADOC. Send comments and recommendations on DA Form 2028 (Recommended Changes to Publications and Blank Forms) to Commander, United States Army Aviation Center and Fort Rucker, ATTN: ATZO-TDS-D, Fort Rucker, AL 36362-5263.

Unless this publication states otherwise, masculine nouns and pronouns do not refer exclusively to men.

This publication has been reviewed for OPSEC considerations.

This publication implements the following international agreements:

STANAG 2019 (Edition Three)
and QSTAG 509

Military Symbols for Land Based
Systems--APP-6

STANAG 2041 (Edition Four)
and QSTAG 520

Operations Orders, Tables and
Graphics for Road Movement

STANAG 2404	Joint Anti-Armor Operations (Draft)
STANAG 2868 (Edition Four)	Land Force Tactical Doctrine-- ATP-35(A)
STANAG 2889 (Edition Three) and QSTAG 742	Marking of Hazardous Areas and Routes Through Them
STANAG 2999 (Edition One)	Use of Helicopters in Land Operations--ATP-49
STANAG 3497 (Edition One)	Aeromedical Training of Aircrew in Aircrew NBC Equipment and Procedures
QSTAG 277 (Edition Three)	Procedures for the Employment of Helicopters in the Antiarmor Role



CHAPTER 1

UTILITY AND CARGO HELICOPTER FUNDAMENTALS

Utility and cargo helicopters operate throughout the battlefield. As a fully integrated member of the combined arms team, utility and cargo helicopter units conduct combat, combat support and combat service support operations in support of the commander. They operate throughout the battlefield framework and are capable of conducting operations day and night. Utility and cargo helicopters also play a vital role in the conduct of SASO. This chapter explains how utility and cargo helicopters are used in Army operations, roles in the offense and defense, organization of utility and cargo helicopter units, and the capabilities and limitations of those units.

1-1. DOCTRINE FUNDAMENTALS

a. General. Army operations require worldwide strategic mobility. Given this requirement, utility and cargo helicopter units must be able to conduct operations in multiple environments. These operations range from war to stability and support operations. Army aviation doctrine focuses on the integration and synchronization of helicopters as a member of the combined arms team. The ability to successfully conduct operations depends on the correct application of the five basic tenets of Army doctrine. These tenets include initiative, agility, depth, synchronization, and versatility.

(1) Initiative. Initiative allows the commander to set the terms of the battle. Initiative retains friendly force options while limiting the enemy's options. During the defense, operations must be offensive in nature. Utility and cargo helicopters can rapidly move assault forces and supplies to the decisive point on the battlefield. Aviation's capabilities, such as speed, agility, and long range allow the commander to set the terms of the battle. In combat operations, aviation commanders set the tempo by seizing the initiative.

(2) Agility. Agility is the ability of friendly forces to act faster than the enemy and is a prerequisite for seizing and holding the initiative. In combat operations, aviation commanders exploit the agility of their units through speed, mobility, and reaction time. Technological developments in intelligence gathering, aviation mission planning, and communications have improved situational awareness throughout the duration of the mission.

Situational awareness provides an edge to aviation commanders. Aviation assets can now be directed to critical places on the battlefield at critical times.

(3) Depth. Depth is an extension of operations in time, space, resources, and purpose. In combat operations aviation commanders understand depth as the ability to conduct simultaneous close, deep, and rear operations. Commanders sustain the momentum by taking advantage of all available resources. With access to joint and combined arms capabilities, aviation commanders can plan for and control numerous utility and cargo operations simultaneously.

(4) Synchronization. Synchronization is the application of military forces in time, space, and purpose to produce maximum combat power at the decisive place and time. Synchronization requires intensive planning to ensure that all elements of combat power are delivered at the decisive time and place. It requires exact coordination among the various combat, combat support, and combat service support units involved in an operation. Joint and multinational capabilities must be considered when applicable. Effective liaison is imperative for the utility and cargo helicopter unit to be fully synchronized with the supported unit.

(5) Versatility. Versatility is the ability of units to meet diverse mission requirements. It is the essence of utility and cargo helicopter operations. Aviation commanders demonstrate versatility by their ability to shift focus, tailor forces, and conduct simultaneous operations rapidly and efficiently. Aviation forces must be prepared to deploy from one geographical region to another and from one type of operation to another.

b. Framework of the Battlefield. The Army's warfighting doctrine specifies that deep, close, and rear operations occur simultaneously. A utility and cargo helicopter unit can conduct operations throughout the entire framework during offensive and defensive operations. Deep operations allow corps and division commanders to influence the close operations before the enemy closes with friendly forces. During the conduct of close operations, utility helicopters allow the corps and division commander to exploit success by rapidly shifting forces on the battlefield. Utility and cargo helicopters can influence the commander's rear area fight by rapidly moving and assaulting forces to stop penetrations and enemy assaults into the rear area.

c. Utility and Cargo Helicopters in Combat Operations. The force commander's assessment of the factors of METT-T influences the missions that are assigned to utility and cargo helicopter units. Utility and cargo helicopter units will conduct combat, combat support, and combat service support operations day and night throughout the battlefield framework. With the aviation commander's assistance, the force commander determines how to best employ the utility and cargo helicopters. From the force commander's mission and intent, the aviation unit commander determines how best to employ his unit. Some of the common missions the utility and cargo helicopter unit conducts are--

- Air assault operations.

- Air movement operations.
- C².
- Aerial mine delivery operations (Volcano).
- CSAR.
- CASEVAC.

1-2. UTILITY AND CARGO HELICOPTERS IN THE OFFENSE AND DEFENSE

a. *Forms of the Offense.*

(1) *Movement to contact.* A movement to contact is used to gain or reestablish contact with the enemy. It may be used when contact with the enemy has been temporarily lost, or it may be used to initiate an attack. Utility and cargo helicopters may be called upon to conduct the full range of missions during this operation. The search and attack is a limited purpose application of the movement to contact. Search and attack operations are conducted by small, light maneuver units, air cavalry, and air assault forces. The purpose of this operation is to destroy enemy forces, protect the force, deny areas to the enemy, and collect information. Utility helicopters may be called upon to conduct air assault, air movement, C², and CASEVAC missions in support of a search and attack. During a movement to contact, air assaults, air movements, and CASEVAC are missions to be expected. Considering the fluidity of the battlefield during a movement to contact, the aviation unit can expect to conduct C² operations. This allows commanders to move quickly about the battlefield to make critical decisions.

(2) *Attack.* There are two types of attacks--hasty and deliberate.

(a) *Hasty attack.* A hasty attack is an operation for which a unit has not made extensive preparations. It is conducted with the resources immediately available to maintain momentum or take advantage of the enemy situation. Since planning time for a hasty attack is limited, the utility helicopter unit must be prepared to support the force commander with quick, responsive combat, combat support and combat service support operations. Since this type of attack occurs without extensive time to prepare, the utility and cargo helicopter units could expect to concentrate their efforts during the hasty attack to air assaults, air movement of ammunition, CASEVAC, C², and aerial mine operations. The aviation unit staff should focus on being prepared to conduct these missions with little planning and preparation time. To minimize the risk to utility and cargo aircraft, aviation commanders should maximize the use of battle drills. Hasty attacks supported by habitual supporting aviation units increase the likelihood for success.

(b) *Deliberate attack.* A deliberate attack is conducted against an enemy that is well organized and cannot be turned or bypassed. It is planned and carefully coordinated with all elements involved in the attack. The deliberate attack is based on a thorough reconnaissance, an evaluation of all available intelligence and relative combat strength, an analysis of various courses of action, and other factors affecting the situation. With a more deliberate decision making process, air assault operations could be expected for this operation. In the CS and CSS role, utility and cargo helicopters will air move large amounts of ammunition and supplies, primarily repair parts, as the maneuver force prepares for the attack. CASEVAC, C², CSAR, and Volcano are also expected missions to conduct during the deliberate attack.

(3) *Exploitation.* An exploitation usually follows a successful attack and is designed to take advantage of weakened or collapsed enemy defenses. It prevents the enemy from reorganizing a defensive system or conducting an orderly withdrawal. Maneuver forces can be air moved or air assaulted to critical locations on the battlefield to keep the enemy from reorganizing the defense. Since this offensive operation follows an attack, air movement of critical supplies, primarily ammunition, will be critical to allowing the maneuver forces to continue the momentum. Volcano operations, CSAR, CASEVAC, and C² continue to be important roles for utility helicopters in the exploitation.

(4) *Pursuit.* A pursuit is an offensive operation taken after a successful attack or developed during an exploitation. The pursuit takes advantage of enemy weaknesses and its inability to establish an organized defense. As the enemy forces disengage, friendly forces maintain relentless pressure in an attempt to destroy enemy forces completely. A pursuit requires unrelenting speed and mobility to complete the destruction of the enemy. Utility and cargo helicopters contribute to this operation through air assaults, air movements, C² operations, CASEVAC, and Volcano operations.

b. *Forms of the Defense.*

(1) *Area defense.* An area defense is conducted when the maneuver force is directed to defend specified terrain, when the enemy enjoys a mobility advantage over the defending force, when well-defined avenues of approach exist, and the defending force has sufficient combat power to cover the likely enemy avenues of approach in sector. The orientation of the area defense is to deny the enemy designated terrain. Air movement operations are critical for utility and cargo helicopters during an area defense. Utility and cargo units can expect to reposition large amounts of class IV barrier material, class V, and class IX repair parts forward. Volcano may be employed to emplace obstacles at critical places during the battle. C² and CASEVAC operations will also be a vital mission for the utility helicopter unit to perform during the area defense.

(2) *Mobile defense.* A mobile defense allows the enemy force to advance to a point where it is exposed to a decisive attack by a striking force. The end state of a mobile defense is destruction of the enemy force. In addition

to the missions stated in the area defense, the utility and cargo unit can expect to conduct air assault operations. The force commander may choose to conduct an air assault as part of the striking force to complete the destruction of the enemy.

1-3. UTILITY AND CARGO HELICOPTER UNIT ORGANIZATIONS

a. Assault Helicopter Battalion. The AHB provides division and corps commanders with a highly mobile, flexible, and responsive combat force. This force can plan and execute combat, combat support and combat service support operations. The AHB's speed and mobility enable the commander to adjust force ratios across the entire battlefield, carrying the fight to the enemy.

(1) Corps aviation brigades are authorized one AHB (see Figure 1-1). It consists of a HHC, 2 companies of 15 UH-60s each, and an AVUM. Presently, all corps AHBs are Army National Guard organizations.

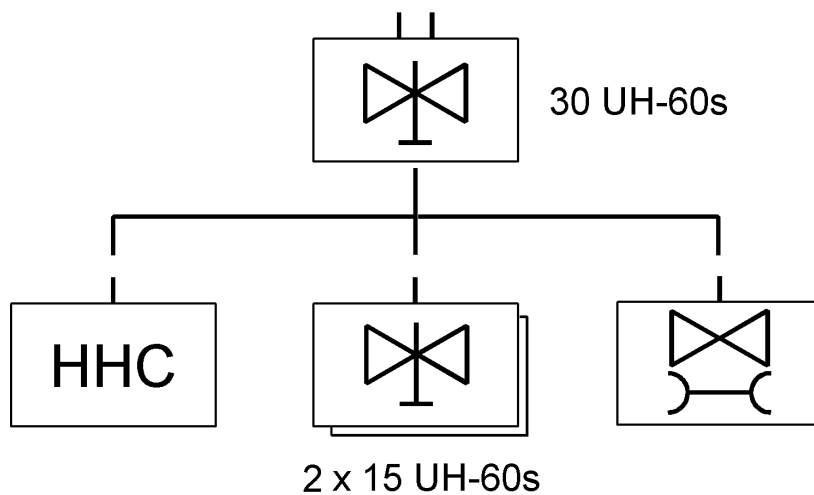

Legend: See the glossary for acronyms and abbreviations.

Figure 1-1. Corps AHB

(a) The HHC provides C², logistics support, and ground maintenance support for the battalion. The headquarters section consists of the battalion commander, his staff, and staff sections. The headquarters company consists of a company headquarters, a supply section, an automotive maintenance section, a food service section, a communications section, a medical treatment team, and a class III platoon.

(b) The AVUM company provides unit level maintenance for battalion aircraft. The company consists of a company headquarters, a quality assurance section, an aircraft maintenance section, and an aircraft component repair section.

(c) The two assault helicopter companies provide the corps commander with air assault capabilities. Each company consists of a headquarters section and three platoons of five UH-60s each.

(2) Light infantry divisions and airborne divisions are authorized one AHB (see Figure 1-2). It consists of an HHC, 2 companies of 15 UH-60s each, one command aviation company of eight UH-60s and four EH-60s, and an AVUM company. This battalion provides the air assault capability for the division commander, as well as supporting C² operations and providing aircraft to the attack battalion of the division for C² and CSAR operations. The organization of the companies is the same as the corps AHB with the following changes:

(a) Class III support is provided by the aviation brigade HHC; the battalion has no class III platoon.

(b) The CAC consists of a headquarters section, one platoon of eight UH-60s, and one platoon of four EH-60s. This company provides the C² capability for the division, aerial mine warfare, and the division's aerial electronic warfare capability. Additionally, the CAC is equipped to conduct missions using the FRIES, paradrop, and HELOCAST systems.

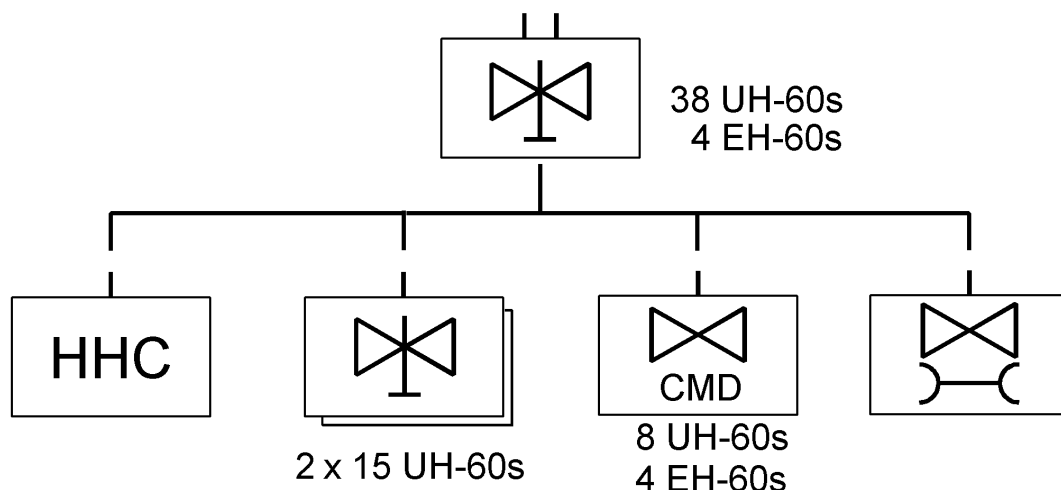

Legend: See the glossary for acronyms and abbreviations.

Figure 1-2. Light division/airborne division AHB

(3) The air assault division is authorized three AHBs (see Figure 1-3). Each battalion consists of an HHC, 2 companies of 15 UH-60s each, and an AVUM company. The AHB of the air assault division provides the division commander with a flexible, highly mobile force capable of conducting air assaults throughout the battlefield framework. The organization of the AHB is identical to the corps AHB.

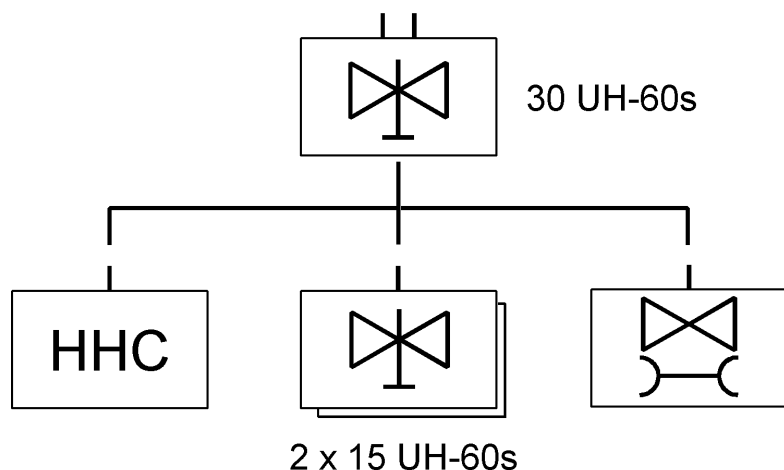

Legend: See the glossary for acronyms and abbreviations.

Figure 1-3. Air assault division AHBs

b. Heavy Helicopter Battalions. All heavy helicopter units provide the force commander a highly mobile and rapid means of moving priority combat systems, personnel, and supplies throughout his AO. Additionally, the heavy helicopter battalion, coupled with AHBs, provides the force commander with a robust air assault force capable of moving large numbers of combat soldiers great distances. The use of the heavy helicopter battalion enables the force commander to rapidly concentrate combat power at the decisive time and place on the battlefield. EAC, corps aviation brigades, and air assault divisions are authorized one heavy helicopter battalion. The EAC heavy lift battalion consists of an HHC, and 2 companies of 16 CH-47Ds (see Figure 1-4). The corps heavy helicopter battalion consists of an HHC and 4 companies of 16 CH-47Ds (see Figure 1-5). The air assault division heavy helicopter battalion consists of an HHC and 3 companies of 16 CH-47Ds (see Figure 1-6).

(1) The HHC performs the same functions as those listed for the corps air assault battalion.

(2) All heavy helicopter companies are designed to operate independently from the parent battalion HHC. Each company consists of a company headquarters, flight operations section, supply section, automotive maintenance section, food service section, communications section, class III platoon, two platoons of eight CH-47s each, and an AVUM platoon.

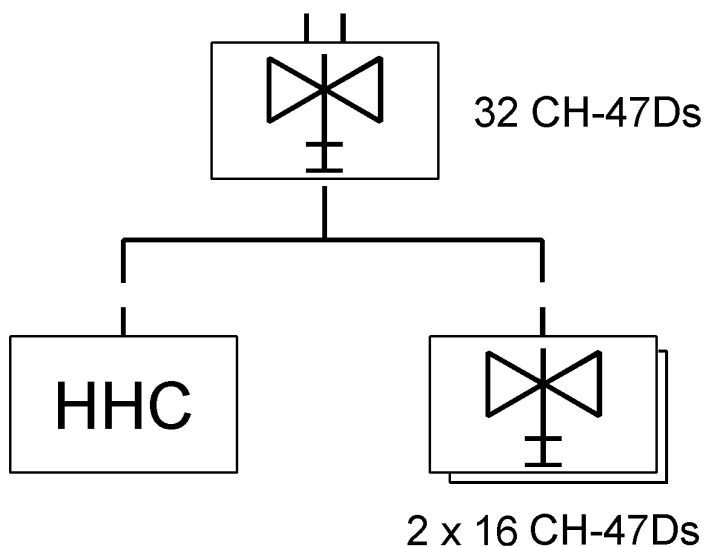

Legend: See the glossary for acronyms and abbreviations.

Figure 1-4. EAC heavy helicopter battalion

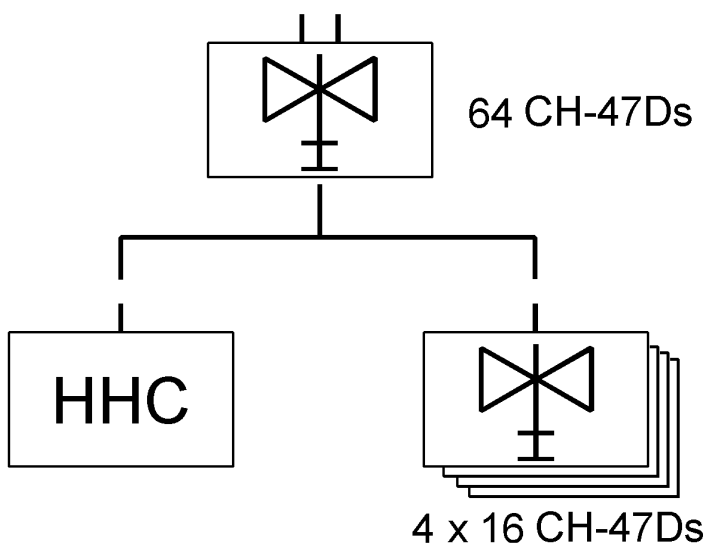

Legend: See the glossary for acronyms and abbreviations.

Figure 1-5. Corps heavy helicopter battalion

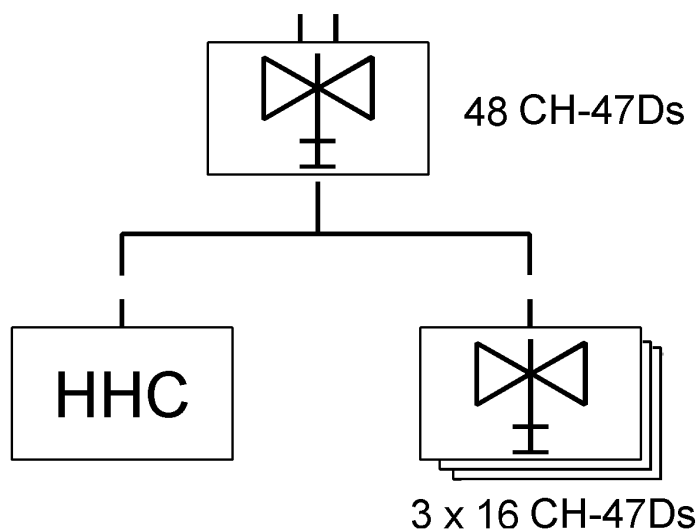

Legend: See the glossary for acronyms and abbreviations.

Figure 1-6. Air assault division heavy helicopter battalion

c. General Support Aviation Battalions. The GSAB provides the armored and mechanized division commanders with a highly mobile, flexible, and responsive combat force. The GSAB's unique makeup provides the commander with a wide variety of capabilities, including air movement operations, CASEVAC, C², and electronic warfare operations. Although it is not designed for it, this battalion has the capability to conduct limited air assault operations. Armored and mechanized divisions are authorized one GSAB (see Figure 1-7). It consists of an HHC; two SACs of eight UH-60s each; one CAC of eight UH-60s, four EH-60s, and six OH-58Cs; and an AVUM company. The organization of the HHC and AVUM is the same as the corps assault battalion.

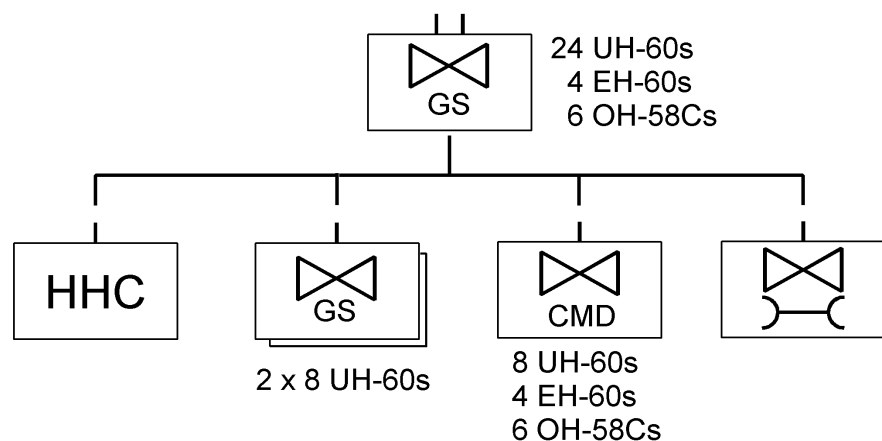

Legend: See the glossary for acronyms and abbreviations.

Figure 1-7. GSAB

(1) Each SAC consists of a company headquarters and two platoons of four UH-60s each.

(2) The CAC consists of a company headquarters, one platoon of eight UH-60s, one platoon of four EH-60s, and one platoon of six OH-58Cs. The OH-

58s may be used in the general support aviation role (C², air movement) or may conduct a target acquisition and reconnaissance role.

d. Combat Support Aviation Battalions. Corps aviation brigades are authorized one CSAB (see Figure 1-8). This battalion's primary mission is to support the logistics effort of the corps. However, companies within the CSAB can augment the corps AHB to provide a large scale air assault force. They may also augment assault and general support battalions of divisions within the corps. The CSAB consists of an HHC, four SACs of eight UH-60s each, and an AVUM company. The internal structure of the HHC, SACs, and AVUM is the same as the divisional GSAB.

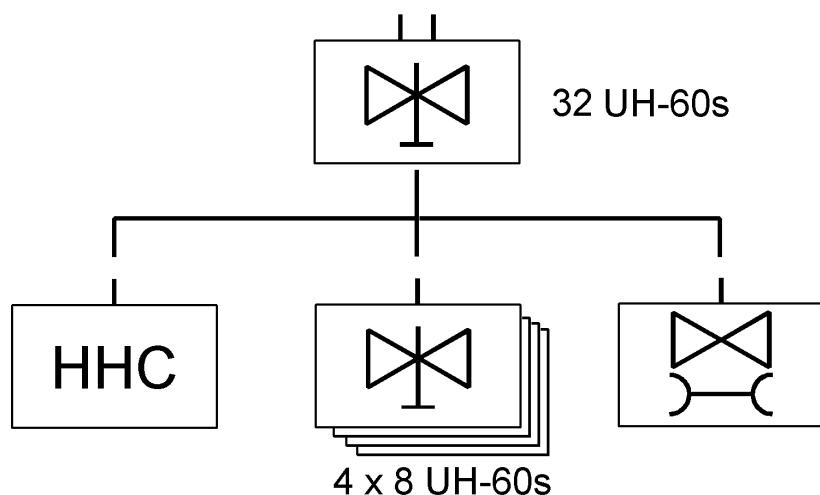

Legend: See the glossary for acronyms and abbreviations.

Figure 1-8. CSAB

e. Command Aviation Battalions. CABs provide enhancement of C³. They accomplish this mission by providing the means by which air and ground commanders can rapidly traverse and see the battlefield. The battalion moves liaison teams, messages, and provides an aerial retransmission capability.

(1) Echelons above corps are authorized one CAB (see Figure 1-9). It consists of an HHC, two SACs of eight UH-60s each, one CAC of eight UH-60s, and an AVUM company. This battalion provides C² support to the theater commander and accomplishes special missions in support of theater operations, such as LRSD insertions.

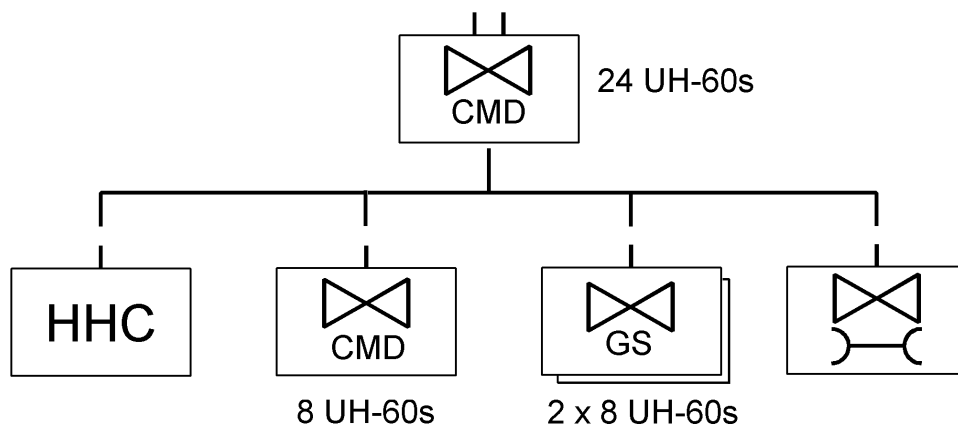

Legend: See the glossary for acronyms and abbreviations.

Figure 1-9. EAC CAB

(2) The corps aviation brigade is authorized one CAB (see Figure 1-10). Its mission is to provide C² support to the corps commander and staff and conduct reconnaissance and target acquisition. It consists of an HHC, three CACs of eight UH-60s each, 1 TARC of 15 OH-58Cs or OH-58Ds (I), and an AVUM company.

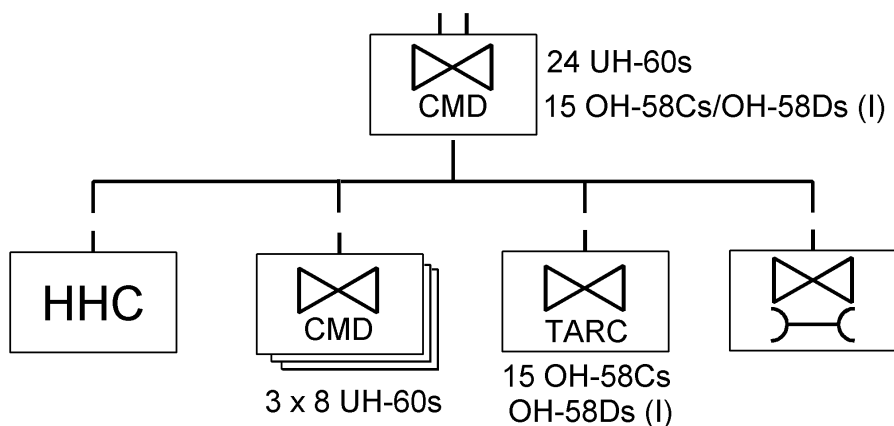

Legend: See the glossary for acronyms and abbreviations.

Figure 1-10. Corps CAB

(3) The air assault division is authorized one CAB (see Figure 1-11). Its mission is to provide C³ enhancement, electronic warfare, aerial mine warfare, and general support aviation to the air assault division. Additionally, the CAB is equipped to conduct missions using the FRIES, paradrop, and HELOCAST systems. This battalion accomplishes much of the air movement operations of the division, freeing up the AHBs and heavy helicopter battalion to focus on the primary mission of air assault. It consists of an HHC, one CAC of eight UH-60s and four EH-60s, one CAC of eight UH-60s, one SAC of eight UH-60s, one pathfinder company, and an AVUM company.

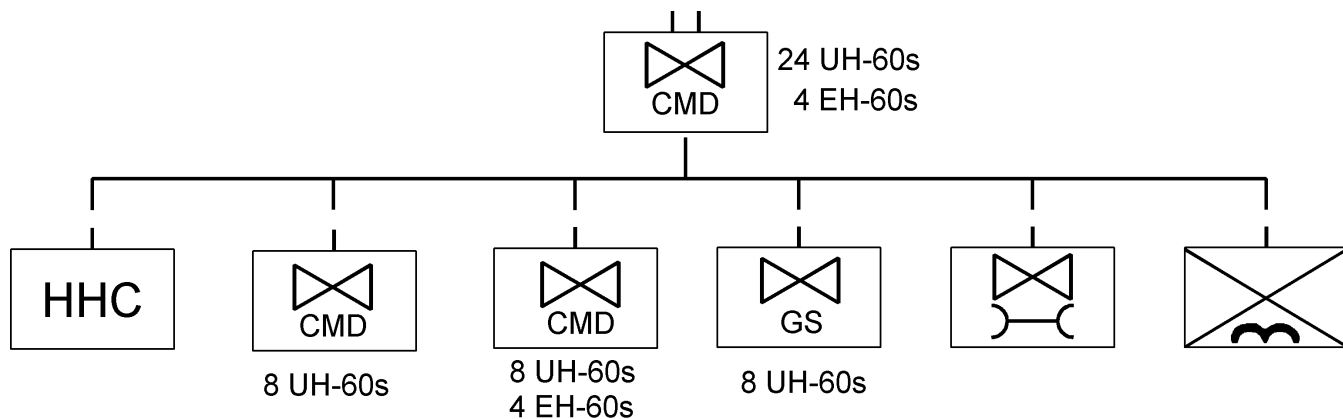

Legend: See the glossary for acronyms and abbreviations.

Figure 1-11. Air assault division CAB

f. Light Utility Aviation Battalion. The light utility aviation battalion provides the corps aviation brigade with the ability to transport staff, personnel, and equipment in support of corps and division operations (see Figure 1-12). All light utility aviation battalions are presently in the Army National Guard. This battalion consists of an HHC and four companies of eight UH-1s each. Like the heavy helicopter company, the light utility aviation companies are designed to operate independently from the parent battalion HHC. Each light utility aviation company has an organic operations and full unit level logistics.

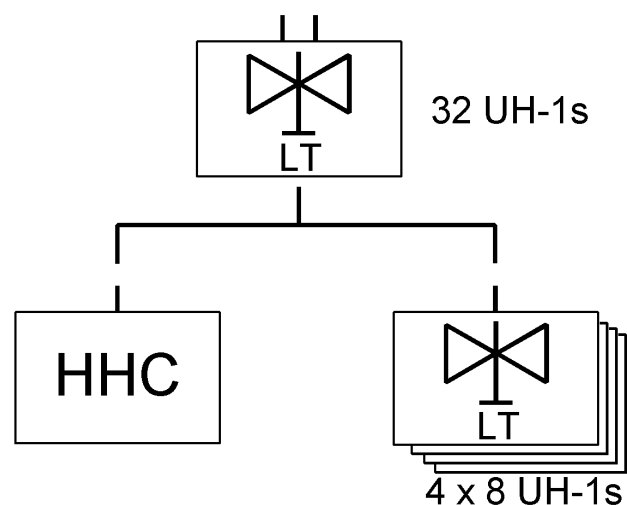

Legend: See the glossary for acronyms and abbreviations.

Figure 1-12. Light utility aviation battalion

g. Regimental Aviation Squadron, Assault Helicopter Troop. The assault troop of the ACR provides the regimental commander with a highly mobile, flexible, and responsive force. This unit can conduct a wide variety of combat, CS, and CSS missions. This troop provides the regiment with the ability to conduct limited air assaults, air movement operations, CASEVAC, and C² operations. The assault troop of the RAS consists of a troop headquarters and three platoons of five UH-60s.

1-4. CAPABILITIES AND LIMITATIONS OF UTILITY AND CARGO HELICOPTERS

a. *Capabilities.* While conducting combat, CS and CSS operations, the utility and cargo helicopter unit significantly influences the commander's fight by--

- (1) Conducting day, night, and limited visibility combat, CS, and CSS operations across the entire length and width of the battlefield and in SASO.
- (2) Conducting operations against an enemy force from multiple directions.
- (3) Influencing the tempo of friendly operations.
- (4) Rapidly moving tactical units over great distances during close, deep, and rear operations.
- (5) Bypassing enemy positions, barriers, and obstacles to achieve surprise.
- (6) Enhancing the C³ process.
- (7) Moving large amounts of supplies and equipment to sustain combat operations.
- (8) Moving critical repair parts quickly to increase the combat power of the force.
- (9) Emplacing Volcano minefields to disrupt, delay, turn, or block enemy forces.
- (10) Conducting operations beyond the FLOT.
- (11) Providing CSAR coverage in the AO.
- (12) Conducting CASEVAC and personnel replacement operations (transporting replacements forward).
- (13) Providing refuel capability using Fat Hawk/Fat Cow.
- (14) Performing DART.

b. *Limitations.* Utility and cargo helicopter units are subject to operating limitations that the commander must consider when planning the employment of the utility unit. These limitations are as follows:

- (1) The extreme environmental effects (temperature, altitude) may reduce the capabilities of the aircraft to perform the full range of missions.
- (2) The unit has limited capability to secure unit AAs with organic assets.

(3) Missions require adequate planning and coordination time to fully capitalize on utility helicopter assets.

(4) The unit may be subjected to inadequate CS/CSS because of its extended range of operations and limited organic logistics support.

(5) Terrain may limit the availability of adequate PZs and LZs.

(6) Helicopters require large amounts of fuel (class III) and repair parts (class IX).

(7) Some units can provide a limited number of aircraft to support a large combat force.

(8) Battlefield obscuration (smoke, dust) can have a detrimental effect on utility helicopter operations.

(9) Crew endurance and crew sustainment cycle affects continuous operations. Based on risk reduction measures taken by the commander, there are planning methods that allow for 24-hour support without affecting crew endurance cycles.

(10) Cargo helicopters have a large, unsuppressed IR signature that makes them vulnerable to IR missiles.

(11) Helicopters require extensive maintenance support for extended operations.



CHAPTER 2

BATTLE COMMAND

Battle command may be the most difficult and the most important ingredient for successful utility and cargo helicopter operations. This chapter discusses the duties of the aviation commander and staff, command post operations, the decision making process, and communications.

2-1. COMMAND AND CONTROL DUTIES AND RESPONSIBILITIES

a. Commander. The utility and cargo helicopter commander is responsible for the overall success of unit operations. He receives missions from higher headquarters, decides how his assets are to be employed, and directs the execution of operational plans. The commander must position himself during planning and execution in a location that will ensure success of the mission. At times, the commander of the utility and cargo unit may conduct liaison functions, ensuring that his assets are being used to their maximum capabilities by the supported unit. During mission execution the commander must position himself to provide command, control, and support to his committed assets to ensure their success. The commander maintains control and directs actions by--

- Issuing specific orders.
- Issuing guidance and commander's intent to the staff that directs their planning efforts.
- Developing an estimate based on METT-T.
- Allocating available resources to accomplish tasks.
- Establishing SOPs to ensure personnel accomplish routine tasks and operations.
- Applying risk management to protect his force from unnecessary risk.

b. Staff. Through the staff, the unit commander must monitor the continuous flow of information, make timely decisions, and issue clear, concise orders. The primary functions of the staff are to--

- Provide the commander with the essential information he needs to make the best decision.
- Provide the subordinate units the information and resources they need to successfully execute their assigned missions.

The staff must have the latitude and flexibility to make recommendations or

decisions when appropriate in response to rapidly changing situations on the battlefield. The staff must also deal with routine matters associated with running the battalion, to allow the commander to focus on the critical decisions to be made. [FM 101-5](#) describes the general duties and responsibilities of staff officers. Additional, specific responsibilities of utility and cargo unit staffs are listed below:

(1) Executive officer. The XO is the principal assistant to the commander and has the responsibility of directing the staff. The XO may assume command in the absence of the commander. The duties and responsibilities of the XO should be clearly defined by the battalion commander. The duties the commander may assign the XO may include any or all of the following:

(a) Staff supervisor. As the staff supervisor, the XO is responsible for directing the staff, monitoring the execution of staff tasks, and coordinating the staff's efforts. The XO is responsible for monitoring the staff planning process, keeping the staff on the timeline, and ensuring staff planning remains focused on the commander's intent.

(b) Tactical operations center supervisor. The XO may be responsible for the operations of the TOC. This allows the XO to keep abreast of the current situation, keep the TOC focused, and ensure that planning for future operations is ongoing while the commander controls the current fight.

(c) Logistics manager. The XO may be responsible for managing, planning, and synchronizing the logistics and maintenance effort of the battalion. The commander may designate the S3 to supervise and control TOC operations while the XO ensures that all logistics functions are in place and synchronized with current battalion combat operations.

(d) Administrative/logistics operations center supervisor. The XO may be designated as the supervisor of the ALOC (the aviation CSS CP that is part of the main CP). This allows the XO to keep the S1 and S4 focused on the logistics systems and to ensure that combat plans and logistics are synchronized. By locating in the ALOC the XO will be able to anticipate logistics shortfalls and develop solutions before they affect current battalion operations.

(2) S1. The S1 operates from either the TOC or the ALOC. He is responsible for all matters and issues relating to personnel in the battalion. The S1--

- Monitors personnel accountability and strength reporting.
- Processes replacements and develops procedures for integrating combat replacements into the unit.
- Ensures casualties are reported timely and accurately.
- Monitors media operations.

- Administers the unit POW program.
- Plans health service support for the unit, coordinating with medical assets for required support and planning the casualty evacuation of unit soldiers in support of unit operations.
- Monitors unit strength and estimates personnel losses.
- Coordinates religious, legal, finance, and public affairs services.

(3) S2. The S2 normally remains at the TOC where communication assets are available for coordinating surveillance and reconnaissance activities and updating the current situation. The S2--

- Conducts IPB.
- Provides weather information and analysis of the effects of weather on the mission.
- Develops and refines SITEmps.
- Develops an assessment of environmentally sensitive areas within the AOs for depiction on SITEmps.
- Assists the S3 in developing target lists based upon the current enemy situation.
- Prepares an analysis of the AOs and the area of interest.
- Prepares intelligence and counterintelligence estimates.
- Informs the commander on enemy capabilities and the enemy's ability to effect the unit's mission.
- Develops the R&S plan with the S3.
- Develops the IPB and PIR.
- Tracks the enemy situation and forecasts enemy intentions.
- Develops an event template and DST for the AA, which results in decision points necessary for planning and executing AA displacement.

(4) S3. The operations officer coordinates and plans the combat operations of the unit. He monitors current and future operations, ensuring essential combat assets are provided when and where required, and anticipates developing situations and missions. The S3 and his staff section must be constantly aware of the changing situation. They must be fully aware of the combat capability of the unit and advise the commander of the ability of the unit to meet all assigned missions. The S3 must coordinate closely with all staff sections, ensuring the staff is synchronized to fully support current and future operations. The S3 section must be able to conduct current operations while looking ahead and planning future operations. If the commander employs a TAC, the S3 will collocate with the TAC to execute current operations. Like the commander, the S3 may fill the role of an LNO when the unit's assets are task organized under another headquarters. This way, the S3 can ensure that the assets are employed within their maximum capabilities. The S3--

- Maintains current combat power of the unit.
- Integrates fire support into unit operations.
- Prepares plans and orders.
- Establishes communications priorities.
- Coordinates and controls civil-military operations.
- Coordinates airspace and conducts airspace management.

- Requests airspace control measures, if required.
- Selects the locations of CPs (TOC, TAC).
- Monitors and controls the TAC CP.
- Coordinates and integrates force protection activities, to include the development, implementation, and evaluation of risk control measures using the risk management process.

(5) S4. The S4 operates from either the TOC or the ALOC. He must thoroughly understand the commander's intent and initiate timely actions to support that intent. The S4 must monitor the tactical situation to provide timely logistics support. He must be integrated into the operational planning to fully synchronize logistics with the combat plans and orders. The S4 keeps the commander informed on all matters regarding logistics. The S4--

- Prepares logistics estimates.
- Tracks the status of MSRs and requests alternate MSRs, if required.
- Tracks current unit status of supplies and maintenance.
- Plans and controls movements.
- Plans for supply and maintenance requirements.
- Plans for transportation requirements and requests additional assets if the transportation ability of the unit is exceeded.
- Requests, receives, stores and distributes supplies.
- Establishes CSS and maintenance support priorities according to the commander's guidance.
- Determines the requirements for civilian labor and logistics support.
- Collects and disposes of excess property, salvage, and captured material.
- Collects and prepares hazardous wastes for shipment to a treatment, storage, and disposal facility.
- Collects and ships all hazardous materials and hazardous wastes according to applicable environmental and shipping regulations.
- Conducts a CSS rehearsal, synchronizing all CSS elements with current unit operations.

(6) Command sergeant major. The CSM is the senior NCO in the battalion. He acts in the name of the commander when dealing with the other NCOs in the battalion and is the commander's primary advisor concerning enlisted soldiers. He is not an administrator, but must understand the administrative, logistics, and operational requirements of the battalion. He is the most experienced soldier in the battalion and keeps his finger on the pulse of the command. He focuses his attention on any function critical to the success of the operation. To accomplish this task, the CSM must be mobile. He must be able to move where the commander needs him the most. The CSM assists the commander by--

- Training company first sergeants.
- Monitoring NCO development, assignments, and promotions within the battalion.
- Monitoring the level of proficiency of training and the morale of subordinate soldiers.

- Providing recommendations and expediting the procurement and preparation of replacements.
- Monitoring logistics functions in the battalion.
- Assisting in controlling battalion movement.
- Leading the battalion reconnaissance or quartering party during AA occupation.

(7) Special staff officers. Special Staff Officers assist the battalion commander in professional, technical, and other functional areas. In utility and cargo helicopter units, the special staff may include--

- S3 (Air).
- A²C² personnel.
- Communications-electronics officer.
- CHEMO.
- Safety Officer.
- Chaplain.
- Flight surgeon.
- FSO.
- ALO.
- ADA officer.
- Battalion SIP.
- Battalion TOO.
- Aviation LNO.

2-2. COMMAND RELATIONSHIPS

The command relationships of the utility and cargo helicopter unit are organic, assigned, attached, OPCON, and TACON. Utility and cargo helicopter assets can expect to be employed on the battlefield in all of these command relationships. Specific definitions and missions are listed below.

a. Organic. Organic assets are "assigned to and forming an essential part of a military organization. Organic assets are those listed in the unit's MTOE." Utility and cargo helicopters are in this command relationship when conducting missions in support of their own unit.

b. Assigned. Assigned is "to place units or personnel in an organization where such placement is relatively permanent, and/or where such organization controls or administers the unit or personnel for the primary functions of the unit." As in organic, utility and cargo helicopters will have this relationship when C² is exercised by their parent headquarters.

c. Attached. Attached is the "placement of units or personnel in an organization where such placement is relatively temporary. The commander of the unit that receives the attachment is responsible for the sustainment and logistics support that is beyond the capability of the attached unit." An example of this relationship is a cargo helicopter platoon being attached to a division for the duration of an operation. Another example is when utility helicopters are attached to an AHB to form an aviation task force. Aircraft participating in SASO may also be attached to another headquarters.

d. Operational Control. OPCON is a "command relationship that gives a commander the authority over subordinate forces to organize and employ the assets, designate objectives, assign tasks, and give direction regarding accomplishment of the mission. The commander exercising OPCON authority has no responsibility for logistics sustainment of the supporting unit." Utility and cargo helicopters will be under the OPCON of the AATFC during the conduct of an air assault operation.

e. Tactical Control. TACON is a "command relationship that gives a commander authority over assigned or attached forces or commands, or military capability or forces made available for tasking, that is limited to the detailed, and, usually, local direction and control of movements or maneuvers necessary to accomplish missions or tasks assigned." Utility and cargo helicopter units may be TACON during the conduct of SASO operations, particularly when working for a nonmilitary agency. An example of this is when SAC is under the TACON of the DEA for counter-drug operations, and when a heavy helicopter platoon is under the TACON of the U.S. Forest Service for a forest fire mission.

2-3. SUPPORT RELATIONSHIPS

The support relationships of the utility and cargo helicopter unit are DS and GS. Utility and cargo helicopter assets can expect to be employed in the DS and GS role. Specific definitions and missions are listed below.

a. Direct Support. DS is a "mission requiring a force to support another specific force and authorizing it to answer directly to the supported force's request for assistance." Utility and cargo helicopters will often be placed in a DS role for the conduct of air movement operations, particularly in the conduct of a logistics movement. When operating in a DS role, the missions can be coordinated directly between the aviation unit and the supported unit.

b. General Support. GS is the "support that is given to the supported force as a whole and not to any particular subdivision thereof." Utility and cargo helicopters assigned at EAC and corps levels may be placed in GS to several units within the theater or corps. These units will receive missions from their parent headquarters based upon support priorities established by theater and corps commanders. When operating in a GS role, the supported unit must request aviation support from the appropriate headquarters (division G-3 for divisional aviation assets, corps G-3 for corps aviation assets).

2-4. DECISION MAKING IN THE UTILITY AND CARGO HELICOPTER UNIT

The military decision making process is discussed in-depth in [FM 101-5](#). This section is designed to provide utility and cargo commanders and staffs with guidance on decision making for their particular unit. Often, utility and cargo units do not have the time to complete a detailed deliberate decision making process. However, it is critical that utility and cargo commanders and staffs conduct the decision making process. Even if time does not permit a full deliberate process, an abbreviated process is essential for mission success.

a. Abbreviated Decision Making. The focus of any decision making is to quickly

develop a flexible plan that increases the likelihood of mission success with the fewest casualties possible. While difficult to do in an abbreviated manner, all staffs must be capable of producing a sound plan in a short time. Anticipation, coordination, and preparation are the keys to success in a time constrained environment. There are three primary techniques to save time in the decision making process.

(1) Increase the commander's involvement, allowing him to make decisions during the planning process without waiting for detailed briefings.

(2) The commander must become more directive in his guidance and limit options. This focuses the staff on the things the commander feels are most important.

(3) The commander must limit the number of COAs that are developed. In extreme cases, he may direct that one course of action be developed. In a time constrained environment, the importance of WARNORDs increases as available time decreases. Subordinate units must have information to allow them to conduct parallel planning.

b. *Mission Analysis.* Mission analysis is the first major step in the tactical decision making process and, for the utility and cargo commander and staff, is the critical step in successful mission accomplishment. Often the utility and cargo unit will be tasked to support different missions and units. The commander and staff must make a careful analysis of their mission to ensure they can meet all assigned missions with available assets. Mission analysis consists of command and staff actions related to--

- Gathering facts.
- Making assumptions.
- Analyzing higher mission and intent.
- Developing specified and implied tasks from orders, guidance, and habitual relationships.
- Determining essential tasks.
- Determining limitations and availability of assets.
- Developing a list of all important information needed (RFIs) from higher headquarters and submit the list to the higher headquarters.
- Identifying force protection hazards.

Once these factors are analyzed the commander can approve a restated mission for the unit.

c. Development of a Concept of Support. For utility and cargo units that will conduct numerous CSS missions where the unit's aircraft are task organized to another headquarters (OPCON, DS, or GS), the mission analysis should be further developed into a concept of support for their unit. The commander and staff must assess the status of the unit (maintenance, crew cycle) and match that against the current mission load of the unit. Based on this assessment, the staff determines the best method to employ the unit aircraft to accomplish all assigned missions. Once the support concept is developed and approved by the commander, the staff develops orders for subordinate units. This process may prove to be most successful for the GSAB, CSAB, CAB, and heavy helicopter battalion.

d. Developing Courses of Action. To develop COAs the staff must focus on key information necessary to make decisions. An essential element in COA development for utility and cargo units is that the course developed must support another unit's scheme of maneuver and purpose. The COA developed by the aviation unit must allow the supported unit commander to achieve his purpose. The COA developed must be done in conjunction with the supported unit to ensure that the two plans are mutually supporting. Focusing on the supported unit's mission and scheme of maneuver during COA development allows the staff to remain focused and will most likely limit the number of COAs developed, thus saving time, which is most often limited. COA development includes the following elements:

- Analysis of assets available (maintenance, crew cycles, crew experience).
- Develop a scheme of maneuver.
- Determine C² means and minimum required control measures.
- Develop a COA statement and sketch.

e. Course of Action Analysis and Comparison. Staff analysis identifies the best COA for recommendation to the commander. Analysis begins when the S3 briefs the staff about each COA. An analysis of each COA is accomplished by each staff section to determine if any are unfeasible. During the analysis, information identified by any staff member that might affect another staff section's analysis must be shared. If a COA is deemed inadequate, the staff must modify the COA to make it feasible or eliminate it. Once a COA is determined to be feasible, it is compared with other feasible COAs. The results of this comparison are briefed to the commander who decides which COA will be developed into the order.

f. Decision Making Process Planning Considerations. The commander and staff must always keep in mind the following considerations when developing the orders for the utility and cargo helicopter unit:

(1) Staff integration. All staff members play a critical role in the development of plans and orders. The XO must ensure that each staff section is integrated into the planning process so that all battalion elements can be synchronized.

(2) Time management. Planning for utility and cargo helicopter missions requires detailed coordination with external units. When supporting other units, often information received initially is incomplete. The staff must work diligently to gather all facts regarding missions in a timely manner. The XO must ensure the staff remains on a strict timeline, and that orders are produced in a timely manner, providing the subordinate units with maximum planning time.

(3) Warning orders. WARNORDs may be written or verbal, but they must occur to ensure that as information flows into the battalion, the companies are updated with all the latest mission data. In utility and cargo helicopter operations, all of the information may not be available at one time, so effective WARNORDs by the staff are critical to the success of the unit's missions.

2-5. COMMAND POSTS

a. Main Command Post. The main CP includes all soldiers, equipment, and facilities employed to C² the battalion. The TOC is the operations cell within the main CP. Additionally, the commander may establish an ALOC within the main CP, or these functions may be controlled from the TOC. The battalion TOC is the control, coordination, and communications center for the utility and cargo helicopter battalion. The TOC is located in or near the battalion AA and is composed of the S2, S3, and special staff sections. TOC operations are supervised by the XO or S3, as designated by the commander. TOC operations are critical to the success of the unit. Therefore, personnel access to the TOC must be kept to a minimum to avoid confusion.

(1) Tactical operations center functions. The TOC monitors and assists in C² by maintaining contact and coordinating with higher, adjacent, and supported units. The TOC continuously updates friendly and enemy situations, keeping up to date information on the locations of known enemy and friendly units on the battlefield. The TOC plans and coordinates future missions for the battalion and tracks the status of current missions. It analyzes and disseminates information, maintains situation maps, maintains current status of the battalion's combat capability, and synchronizes the staff to ensure all battalion operations are fully supported.

(2) Tactical operations center operations. The primary considerations in positioning the TOC are communications, accessibility, and survivability. Personnel who operate in the TOC must be organized to maintain TOC functions and provide security on a continuous basis. Coordination between the S3 and S1/S4 must be continuous to ensure that CSS is factored into every mission. The security of the TOC is enhanced by its capability to rapidly displace. Displacements should be planned to ensure that the TOC is stationary during critical stages of the battle.

b. Tactical Command Post. When established by the commander, the TAC is the forward, decision making node of the battalion. It usually is minimally staffed and contains only the minimum essential equipment to conduct effective C². The TAC does not plan for future operations, but focuses on effective C² of current combat operations. It may be established on the ground, or it may be airborne in

a C² aircraft. The TAC CP should be located in an area where the commander can execute C² over his units. For utility and cargo missions supporting different headquarters simultaneously, the commander must decide where the critical location is on the battlefield and position the TAC to support what he considers his priority mission.

c. Administrative/Logistics Operations Center. The ALOC is the CSS center for the battalion and is located within the main CP. The S1 and S4 operate the ALOC. The S4 is responsible for the operation of the ALOC. Besides being the CSS center for the battalion, it may also function as an alternate CP should the TOC or TAC be compromised. The XO must also take responsibility for supervising the activities of the ALOC. The primary function of the ALOC is to plan and coordinate the CSS for the battalion and to track the current status of CSS assets in the battalion. The S1 and S4 must constantly interface with the other staff sections to ensure CSS is integrated into all battalion operations. The ALOC must maintain a current status of the maintenance posture for the unit, both ground and air. As an alternate CP, the ALOC must keep up to date on the current status of combat operations in the battalion. It should maintain maps depicting the current combat operations. Additionally, the ALOC maintains a map showing the current MSRs.

2-6. COMMUNICATIONS

a. Radio Nets. Successful employment of utility and cargo helicopter battalions depends upon their ability to communicate with all echelons. The primary means of tactical communications within the battalion is FM-secure radio. The use of UHF and VHF nets by battalion aircraft helps reduce the load on the FM nets. These radios are primarily used by companies to control combat operations. The battalion commander normally conducts C² functions within the battalion on the FM-secure net. The utility and cargo battalion must maintain MSE communications as well. During the planning process, coordination with the supported unit is essential, and may often be outside the range of FM communications. When emplacing the TOC, the commander must consider the location in relation to the MSE coverage plan, to ensure he can effectively command the unit and coordinate for future operations. Figures 2-1 and 2-2 show example radio nets for a utility and cargo battalion.

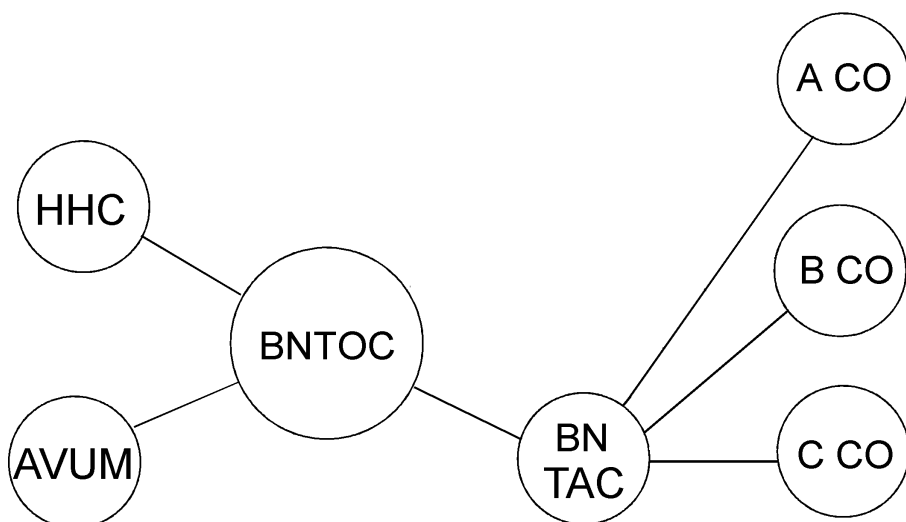

Legend: See the glossary for acronyms and abbreviations.

Figure 2-1. Sample battalion command FM net (secure)

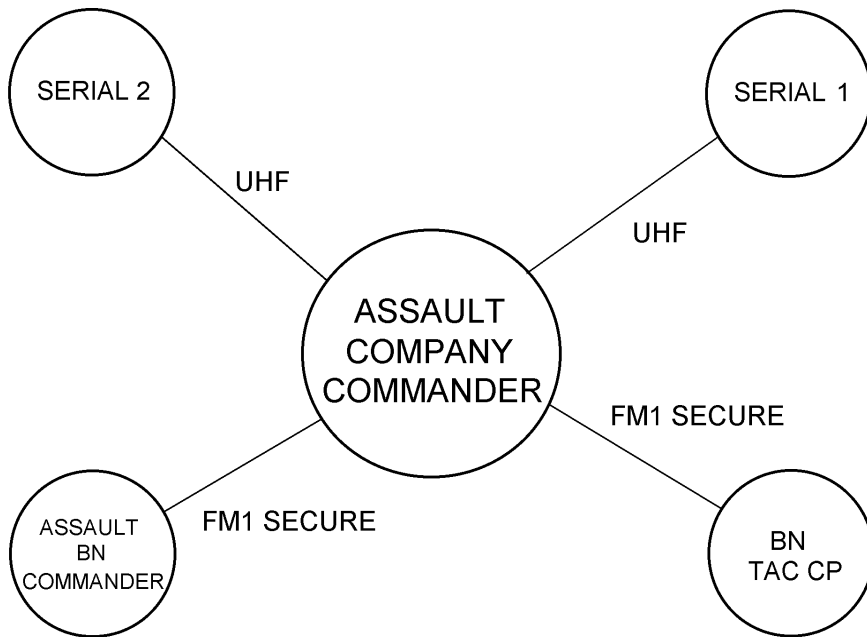

Legend: See the glossary for acronyms and abbreviations.

Figure 2-2. Sample company nets

b. Wire. Though its wire laying capability is limited, the utility and cargo battalion has the assets to establish wire communications in the AA. The wire network links the TOC with the companies and the ALOC. Figure 2-3 shows a battalion wire net.

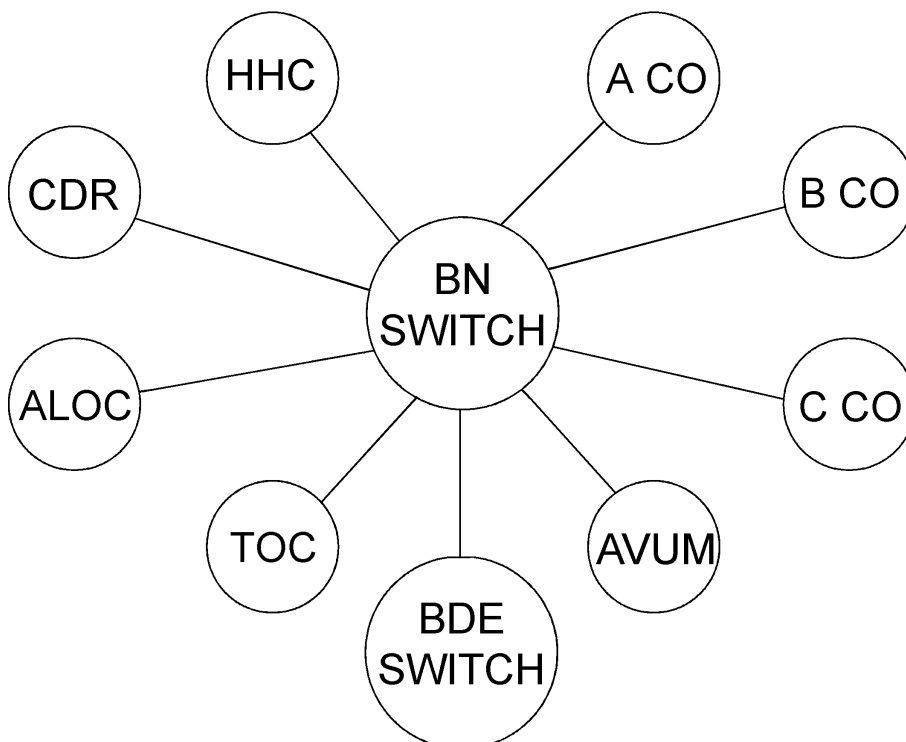

Legend: See the glossary for acronyms and abbreviations.

Figure 2-3. Sample battalion wire net

c. Aviation Mission Planning System.

(1) The AMPS is an automated aviation mission planning/synchronization tool designed specifically for the aviation commander. There are two levels of AMPS--brigade/ battalion and company. Each level provides the capacity to plan and synchronize aviation operations.

- Brigade/battalion AMPS. Hosted on the CHSII platform, consisting of a TCU with 128 MB of RAM, a 4.2 GB removable hard disk drive, a CD-ROM drive, a 1.3 GB magneto optical drive, a 19-inch color monitor and a character graphics computer.
- Company AMPS. Hosted on the CHSII platform or LCU. All components of the company AMPS are the same as the battalion/brigade AMPS.

All of the AMPS components have been ruggedized for field use. Additionally the AMPS has a 9600 baud modem. AMPS software allows two systems to transfer data files over telephone lines. Secure or nonsecure files may be transmitted. Some utility and cargo aircraft have data transfer receptacles and data cartridges for loading/downloading mission data in the aircraft.

(2) The functions of AMPS can be broken into 3 areas--tactical planning, mission management, and maintenance management functions.

(a) Tactical planning function. This function includes planning tasks normally performed at the brigade/battalion level, such as intelligence data processing, route planning, communications planning, navigation planning, and mission briefing/review.

(b) Mission management function. This function includes planning which occurs at company level. Planning at company level consists of aircraft weight and balance, aircraft performance planning, route planning and timing, crew endurance planning, and other flight planning.

(c) Maintenance management function. This function is provided primarily for the unit level maintenance functions. It will permit postmission downloading of aircraft data for maintenance personnel.

(3) AMPS data may be saved onto a DTC that is used to upload mission data to the host aircraft via the data transfer module. The data created at battalion level is given to the companies for detailed company and aircrew planning. There are six printed hard copy output products--weight and balance forms, strip maps, flight plans, OPORDS/FRAGOs, route navigation cards, and communications cards.

(4) AMPS map data bases are created from ADRG CD-ROM and DTED media available from the Defense Mapping Agency. The maps obtained on the CD-ROMs are digitally cut and pasted for a particular AO and stored for ready access on the magneto optical drive disks or the AMPS hard drive.

Data bases of different areas of operations or various scale maps can be maintained and organized on disks.

(5) AMPS can be used for detailed terrain analysis, such as LOS between a PZ and an LZ. Using the perspective view feature, pilots can gain a feel for prominent terrain along the flight route to be flown.

(6) The AMPS is a standard IBM compatible system. The AMPS software uses the UNIX operating system with X-windows environment and a Motif graphical user interface. The AMPS has multiple ports on the back panel that will accommodate commercial, off-the-shelf computer peripherals such as laser printers, mouse pointer, external monitors, or scanners. Some units use the AMPS for more than a mission planner. By using additional removable hard drive system setups, many units use the AMPS as a reconfigurable tactical workstation for word processing, graphics, and data communications.

(7) The AMPS is an additional automation tool that the aviation commander and staff use to manage battlefield information. AMPS and MCS are complementary systems. MCS receives and transfers enemy locations, friendly locations, preplanned artillery locations, and forecast weather to the AMPS. AMPS applies the technical characteristics of the aircraft to give the commander mission alternatives. AMPS also provides the digital transfer device to move this information to the onboard aircraft computers to initialize systems. At the end of the mission, the mission history can be downloaded from the aircraft to the AMPS. Postmission products such as enemy locations and battle damage assessment can be provided to MCS to update the tactical situation.



CHAPTER 3

AIR ASSAULT OPERATIONS

3-1. GENERAL

Army aviation and infantry units can be fully integrated with other members of the combined arms team to form an AATF that is powerful, flexible, and responsive. These task forces project combat power throughout the entire framework of the battlefield. Air assaults provide the force commander with a decisive combat capability. Massing a unit's combat power at the decisive time and place on the battlefield will have a devastating effect on the enemy. It also requires detailed planning and precise synchronization of all elements of the combined arms team. This chapter focuses on air assault operations and discusses air assault planning for the AHB. [FM 90-4](#) discusses the planning for the AATF. This chapter's focus is on planning the aviation portion of the air assault. It is not intended for this chapter to replace [FM 90-4](#). It is designed to complement [FM 90-4](#) and discuss planning considerations that are unique to the aviation units conducting the air assault operation.

3-2. AIR ASSAULTS IN THE CLOSE, DEEP, AND REAR FIGHT

a. Definition. Air assaults are those operations in which assault forces (combat, CS, and CSS), using the firepower, mobility, and total integration of helicopter assets, maneuver on the battlefield under the control of the AATFC to engage and destroy enemy forces or seize and hold key terrain. The number of aircraft involved in the operation does not define the air assault. For example, an assault helicopter battalion will conduct an air assault when it transports an infantry battalion to seize an objective. However, a single UH-60 transporting a LRSD team is also considered an air assault, and, thus, requires the same in-depth planning as a large assault. All air assault operations, regardless of the number of assets involved, must be planned and executed as combined arms operations. Time required for planning may vary depending on METT-T, but planning considerations should be the same.

b. Close Operations.

(1) An air assault operation may be conducted at any time during a ground maneuver force's close operations. The commander may request helicopter assets when he needs speed and mobility to mass his forces where they are most needed. Air assault operations allow the commander to take the battle to the enemy. Rapid movement of forces during the close battle allows friendly forces to maintain momentum and force the enemy to fight in a changing situation. An air assault operation planned in support of the close fight can be executed rapidly when the force commander orders it to be executed.

(2) Air assaults that may be flown in support of close operations include reinforcement of committed forces, assaults to seize key terrain, assaults to set up blocking positions, and air assaults to prevent a penetration.

c. Deep Operations.

(1) Deep operations are activities directed against enemy forces that are not currently engaged but could influence division or corps close operations in the future (approximately 24 to 72 hours). Deep air assaults will normally be conducted during offensive operations. Deep operations are planned by the force commander to influence the close fight. Air assaults executed in the deep fight should be planned with a purpose of having some effect

on the commander's close battle. Deep operations are high risk, high payoff operations that require precise planning.

(2) Planning deep operations creates unique challenges for the AATFC. In deep operations, the AATF will most often be assaulted behind the enemy FLOT. In this operation, the assault helicopter commander must be prepared to provide support to the task force, even after the air assault is complete. Resupply, CASEVAC, and extraction operations during deep operations most likely will not be able to be accomplished by ground. It may be necessary to use CH-47Ds to reposition artillery forward to support the air assault. The assault helicopter commander must plan carefully for these operations to prevent the AATF from becoming cut off from friendly forces. The DOCC at division or corps level will be very active in planning the deep air assault. The AATF and aviation staff must work closely with the DOCC to coordinate and synchronize the deep air assault.

(3) Air assaults that may be flown in support of deep operations include raids to destroy high payoff targets (ammunition storage areas, C² nodes), assaults to cut off retreating enemy forces (pursuits), assaults to set up blocking positions and shape the battlefield, and air assaults to seize and hold key terrain.

d. Rear Operations.

(1) Rear operations are conducted to ensure freedom of maneuver and continuity of operations from the corps rear boundary forward to the rear boundaries of committed battalions. Rear area air assault operations will most likely consist of a TCF designated by the maneuver commander designed to counter a rear area attack.

(2) Rear area operations offer a unique challenge to the AATF in that the location of the air assault will be determined by the enemy. The AATF must, during the planning process, identify the most likely infiltration routes and targets that enemy air assault, airborne, and special operations units will attack. This will allow the AATF to identify potential PZs and LZs, flight routes, and fire support targets. The AATF then develops a plan to monitor these targets for any indications of an attack. A precise observer plan for likely rear area targets, developed by the AATF staff, will allow the air assault to be executed rapidly in the event the rear area is threatened.

(3) Rear area operations are coordinated with designated military police, civil affairs units, and host nation authorities, if required.

(4) The AATF in rear area operations may be given missions that include destruction of enemy forces in the rear area, assault to secure key locations (such as ammunition supply points, and C² nodes), and assaults to fix the enemy until a larger force can move in to destroy the enemy force.

3-3. CAPABILITIES AND LIMITATIONS OF AIR ASSAULT FORCES

a. Capabilities. An AATF provides commanders with unique capabilities. They can extend the battlefield, move and rapidly concentrate large amounts of combat power, and take the battle to the enemy. An AATF can--

- Attack enemy positions from any direction.
- Delay a much larger force without becoming decisively engaged.
- Bypass obstacles and strike objectives in otherwise inaccessible areas.
- Conduct deep operations beyond the FLOT.
- React rapidly to tactical opportunities.

- Exploit success to complete the destruction of the enemy.
- React to rear area threats.
- Rapidly secure and defend key terrain.
- Achieve surprise.
- Conduct operations at night.
- Rapidly reinforce committed units.

b. *Limitations.* The AATF has limitations that the commander must consider. These limitations include--

- Adverse weather (heat, dust, snow, visibility) can hinder helicopter operations.
- Reliance of the AATF on air lines of communications.
- Reduced ground mobility once inserted.
- Availability of suitable landing zones and pickup zones.
- Battlefield obscuration can hinder helicopter operations.
- Significant fuel requirements.
- Requirements for detailed planning.

3-4. AIR ASSAULT ROLES

a. *Utility Helicopters.* The primary mission of the utility helicopter in the air assault is to move troops. With the seats installed, the ACL for the UH-60 is 11 combat-loaded soldiers. If the seats are removed, the ACL increases. Without seats, the UH-60 ACL is dependent on the type of equipment being carried by the troops. For planning purposes, a UH-60 is capable of transporting approximately 16 combat-loaded troops and 20 without full combat loads. The combat loads of the soldiers being lifted will determine the actual ACL for the aircraft. Commanders must consider the risk involved versus mission necessity when deciding whether to operate with or without seats. A secondary mission for the UH-60 is to transport equipment and supplies. The UH-60s can expect to move external loads in support of the assault force. UH-60s may also assist cargo helicopters in conducting an artillery raid by moving artillery or ammunition forward.

b. *Cargo Helicopters.* The CH-47D helicopter provides the AATFC with a tremendous capability. It can be used to move troops and equipment in support of the air assault. In a troop carrying mode the CH-47D can transport up to 31 combat-loaded troops. The CH-47D provides the AATFC the ability to move large amounts of equipment. Missions for the cargo helicopters include artillery raids designed to reposition artillery in support of the air assault, assaulting TOW mounted HMMWVs into designated LZs to support the ground tactical plan, and conducting resupply operations in support of the air assault. Equipment can often be transported as internal or external cargo.

3-5. AIR ASSAULT TASK FORCE KEY PERSONNEL

a. *Air Assault Task Force Commander.* The AATFC is normally the infantry brigade or battalion commander whose units form the predominance of forces in the AATF. Under certain instances, the force commander may designate the aviation battalion commander as the AATFC. This would most likely occur during rear area air assaults or in SASO. In this instance the ground maneuver unit, the supporting artillery, and attack/cavalry helicopter assets will be placed under the OPCON of the aviation battalion commander. The AATFC commands the air assault and is overall responsible for its planning and execution. Since an air assault requires detailed planning, the

AATFC should be the commander of the unit one level above that conducting the mission. For example, for a battalion sized air assault, the brigade commander should be the AATFC, and the battalion commander would be the AATFC for a company sized air assault.

b. Air Assault Task Force Staff. The staff of the AATFC is responsible for planning the air assault operation. The AATF staff has the responsibility for developing the air assault in conjunction with the infantry unit being assaulted and the assault helicopter unit. The AATF staff works closely with the assaulting force headquarters to develop the air assault to support the assault force commander's intent and scheme of maneuver. The AATF staff has the responsibility for synchronizing all elements of the combined arms team and providing the resources to the air assault force to successfully conduct the operation.

c. Air Mission Commander. The supporting helicopter unit provides an AMC. For air assaults involving all, or most, of the battalion assets, the battalion commander should be the AMC. For air assaults conducted by a company within the aviation battalion, the battalion commander may designate a company commander or platoon leader to be the AMC. Figure 3-1 outlines selection criteria for the AATFC and the AMC. The AMC--

- Receives and executes the AATFC's guidance and intent.
- Ensures that all aviation units (assault, cargo, attack, cavalry) conduct air operations according to the AMB.
- Coordinates actions during the mission and synchronizes cavalry, attack, quickfix, and artillery assets as required.
- Advises the AATFC on any situation that might require him to adjust the air assault scheme of maneuver and recommends changes as required to take advantage of aircraft capabilities.
- Designates a flight lead, serial commanders (if required), an LNO (if not already designated), and a planning cell (if necessary) to the AATF headquarters.

Size Of Unit Assaulted	Avn Unit	AATFC	AMC	Ground TF CDR
Bde	Bn +	ADC/Bde Cdr	Avn Bn Cdr	Bde Cdr
Bn	Bn	Bde Cdr	Avn Bn Cdr	Bn Cdr
Co	Co	Bn Cdr	Avn Co Cdr	Co Cdr

Legend: See the glossary for acronyms and abbreviation.

Figure 3-1. AMC selection guidelines

d. The Aviation Liaison Officer . The LNO is the AMC's representative to the AATFC. His role is to locate with the AATF headquarters and advise the AATFC on all matters relating to aviation's mission in the air assault. The LNO should assist the AMC and AATF staff in developing the air movement table, selecting PZs, LZs, and primary/alternate flight routes, coordinating airspace, developing a fire support plan, and executing PZ operations. The LNO does not replace the AMC during the planning phase of the air assault. The AMC must interact with the AATFC directly on all matters relating to the air assault. In absence of the AMC, the LNO acts according to the AMC's guidance. See Appendix D for suggested formats for an LNO checklist and an LNO briefing. Air assault LNO considerations are as follows:

(1) Deploy early. When the aviation unit is given a WARNORD to conduct an air assault, the commander must delegate an LNO and send him to the AATF headquarters.

(2) Air mission commander's intent. The LNO must understand the intent of the AMC for using helicopters to support the air assault. The LNO must constantly contact the AMC and keep him updated on air assault planning status and receive guidance from the AMC.

(3) Keep the air mission commander informed. The LNO must advise the AMC on all changes and adjustments to the air assault made by the AATFC.

(4) Decision making. The LNO should not make decisions for the AMC unless the AMC has delegated that authority to him. The LNO should take all issues requiring a decision to the AMC, who should coordinate directly with the AATFC for resolution.

(5) Equipment. The LNO must be equipped for success. He should not become a permanent part of the AATF headquarters. The LNO must have the ability to move and communicate. As a minimum, the LNO should have transportation available to provide the aviation unit with products (overlays, INTSUMs, air movement tables) as they are developed by the AATFC and communications from the AATF headquarters to the aviation unit (MSE, FM). Appendix D gives a suggested format for an air assault LNO checklist.

e. Flight Lead. The flight lead is responsible for assisting the AMC on selecting flight routes (primary and alternate), developing timing for the routes, submitting route card data to the aviation staff for production of route navigation cards, navigating the flight routes, and ensuring the air assault times are met according to the air movement table.

f. Pickup Zone Control Officer. A PZCO is designated for each pickup zone. If there is more than one PZ for the air assault, the AATFC selects a PZCO for each PZ. He organizes, controls, and coordinates PZ operations and pushes the lifted unit out of the PZ. He operates on the designated PZ control frequency and executes mission changes according to the AATFC's orders and aircraft availability. The PZCO executes the bump plan if necessary, and keeps the AATFC informed of any PZ situation that may require adjustment of the air assault scheme of maneuver. The PZCO ensures the PZ is clear of obstacles, marks the PZ, plans PZ security, plans fire support for the PZ, and communicates to the aircraft on the PZ control net. Although the PZCO will be designated from the assault force, the AMC should designate someone from the aviation unit to be present during PZ setup and mission execution to offer aviation expertise and to recommend changes to the PZCO should conditions change, such as changes in wind direction could require changing PZ landing direction. The LNO should be the AMC's choice to be at the PZ during mission execution. The LNO knows the assault force and how they operate. He must collocate with the PZCO and be prepared to offer guidance on PZ operations to ensure that the PZ is setup to ensure mission success. It may be necessary for the AMC to designate more than one person to be at the PZ. If the air assault is planned using multiple PZs, an aviation unit representative should be at each PZ to assist in PZ setup and execution.

g. Aviation Unit Staff. The staff of the aviation battalion conducting the air assault has a significant responsibility during the planning and execution of the air assault operations. Although not being in a direct planning role as the actual AATF headquarters, the aviation staff must interact continuously with the AATF staff to ensure that the aviation assets are used to their maximum capabilities. During the IPC, the battalion S2 and S3 should conduct face-to-face coordination with the AATF staff. The S3 assists the AMC and LNO in the development of the aviation scheme of maneuver and prepares the aviation plans and orders for the commander. The S3 also coordinates airspace and passage of lines and develops a fire support plan to support the aviation task force. The aviation S2 must coordinate with the AATF S2 to develop the threat to the helicopters. In coordination with the AATF S2, the aviation S2 analyzes the threat to the aviation unit and coordinates with the AATF S2 to develop an observation plan to assist in locating actual threats on the battlefield. The aviation S2 also coordinates with the aviation S3 and AATF S3 to develop a fire support plan to support the ingressing helicopters. The aviation staff produces an OPORD for the aviation elements participating in the air assault.

h. Air Cavalry/Attack Helicopter Commander. Air cavalry and/or attack helicopters will be a part of the AATF. The air cavalry troops and attack helicopter companies must be prepared to provide both reconnaissance and security for the AATF. The size of the support provided will

depend on the size of the air assault and may range from a team (2-4 aircraft) to a company/troop (8 aircraft) or more.

(1) Air cavalry commander. During all phases of the air assault, the air cavalry unit is positioned to provide security for the AATF. The air cavalry unit usually precedes the flight and provides reconnaissance for the flight routes, landing zones, and objective areas. The air cavalry unit calls for fire according to the fire support plan developed by the AATF staff. The air cavalry unit may be responsible for initiating SEAD fire missions or preparatory fires around the LZ. During the air assault, the air cavalry unit will be maneuvered by the air cavalry commander under the control of the AMC. The scheme of maneuver for the air cavalry unit will be developed by the air cavalry commander, working with the AATFC and AATF S3. The scheme of maneuver for the air cavalry must support the AATFC's intent and must be briefed to and approved by the AATFC at the air mission brief. Upon completion of the air assault, the cavalry may continue to maneuver in support of the AATF, providing reconnaissance and security during the ground tactical phase.

(2) Attack helicopter commander. The attack helicopter unit's primary mission during the air assault is to protect the AATF. In the absence of air cavalry the attack commander must also provide reconnaissance and security for the AATF. The attack commander maneuvers his assets according to the AATFC's plan, under the control of the AMC. He may provide suppressive fires around the PZ and LZ, attack enemy positions encountered in route to the LZ, or attack repositioning enemy forces. The attack helicopter unit may also serve as the AATF reserve when assaulting against a mechanized or armored threat. The scheme of maneuver for the attack helicopters will be developed by the attack helicopter company commander, working with the AATFC and the AATF S3. The scheme developed will support the AATFC's intent for air assault security. The scheme of maneuver for the attack helicopters will be briefed to and approved by the AATFC during the AMB.

3-6. COMMAND AND CONTROL

The AATFC must address C² requirements early in the planning phase of an air assault. He must establish an effective C² system that allows him to control diverse, widely dispersed air and ground elements between the PZ and the LZ. C² of an air assault operation must be planned in detail. It must address the location of key air assault leaders, the location and composition of C² nodes, and the radio nets that will be used during the air assault operation. The key to successful air assault C² lies in precise, centralized planning and aggressive, decentralized execution.

a. Command Posts. The AATFC designates a CP for the execution of the air assault operation. The AATF CP may be a ground C² node of the AATFC's headquarters, or it may be an airborne C² aircraft. If the AATF CP is on the ground, the aviation unit should collocate a TAC CP with the AATF CP. This will allow the AMC or S3 to interface with the AATFC, maintain communications on the air assault nets through the AATF CP, and maintain communications with the aviation CPs through the aviation unit FM nets. If the AATFC decides to use an airborne CP, the personnel accompanying the AATFC may be limited by the aircraft ACL, but should include, as a minimum, the AATFC, AATF S2, AATF FSO, AMC (or aviation S3), and ALO (if CAS is part of the AATF). The AATF CP should be staffed with the following key personnel:

- (1) AATFC.
- (2) AATF S2.
- (3) AATF FSO.
- (4) AATF S3.
- (5) AMC. (The AMC may be a part of the mission as a crew member. If the AMC is flying on the mission, the aviation S3 should collocate with the AATFC as the AMC's representative.)
- (6) Assault force LNO.

(7) AATF ALO, if CAS is planned or available for the air assault operation.

b. Radio Nets. A mix of air-to-air, air-to-ground, and ground-to-ground radio nets is established to provide the necessary C² for the air assault operation. Air assault operations will most likely occur at night, so C² becomes imperative to reduce confusion. The radio nets established by the AATF will make C² easier and contribute to the success of the operation. Often, there are requirements to monitor more radio nets than are available in the aircraft. Usually, no single aircraft can monitor all of the radio nets needed for an air assault. In this case, the AMC and serial commanders will delegate responsibility for monitoring and reporting on the different nets to other aircraft within the air assault. Figure 3-2 shows the air assault radio nets. Radio nets that will be established for the air assault will be--

(1) **Air assault task force command net.** This net is an FM net (normally the command net of the lifted force or the command net of the AATF headquarters) that is used for ground-to-ground communications during an air assault. It is used by the AATFC to communicate with subordinate unit commanders.

(2) **Combat aviation net.** This is an FM radio net dedicated to air-to-ground communications between the AMC, the AATFC, the PZCO, and the assault force commander. All aviation elements should monitor this net. This net must be dedicated to communications between the lifted unit and the assault helicopter unit. It is used to pass situation reports and mission changes between the assault force and the assault helicopters. It is also used for communications between the AMC/flight leads and the PZCO. The PZCO will communicate with the assault helicopters on this net, providing information on PZ security status, PZ hazards, and changes to PZ operations.

(3) **Air battle net.** The air battle net is normally a UHF frequency for air-to-air communications. All aviation elements (assault helicopters, air cavalry, attack) will monitor this net. The purpose of the ABN is for the AMC to communicate with the commanders of the aviation assets involved in the air assault.

(4) **Fire support net.** This is an FM net operated by the AATF FSO. All aviation elements must have access to this frequency to call for fire support. The fire support net becomes a very busy net during the air assault operation. All of the aviation elements do not need to monitor this net, only those responsible for initiating fire. However, all aircrews must have the frequency and call signs in case they pick up responsibility for calling fire due to losing aircraft.

(5) **Aviation internal nets.** These nets are usually VHF nets and are used for internal flight communications between serials or lifts. Use of a VHF net provides the flight or serial commanders with a dedicated frequency with which to direct and control individual aircraft, platoons, or teams.

(6) **PZ control net.** This is an FM net established by the PZCO used to control the flow of personnel and vehicles in and around the PZ. The PZCO uses this net to communicate with the PZ control elements (security, chinks, PZ control group). This ensures that chinks are lined up in the appropriate area, external loads are ready, the bump plan is activated if necessary, and vehicles and personnel are kept clear of PZ operations.

(7) **Assault battalion command net.** This FM net will be used by the AMC or the battalion S3 to communicate back to the aviation TOC (located in the AA). Communications on this net will be used to keep the TOC informed of the status of the air assault and to alert the TOC of the need for support from the aviation battalion (maintenance, fuel, back-up aircraft, CSAR).

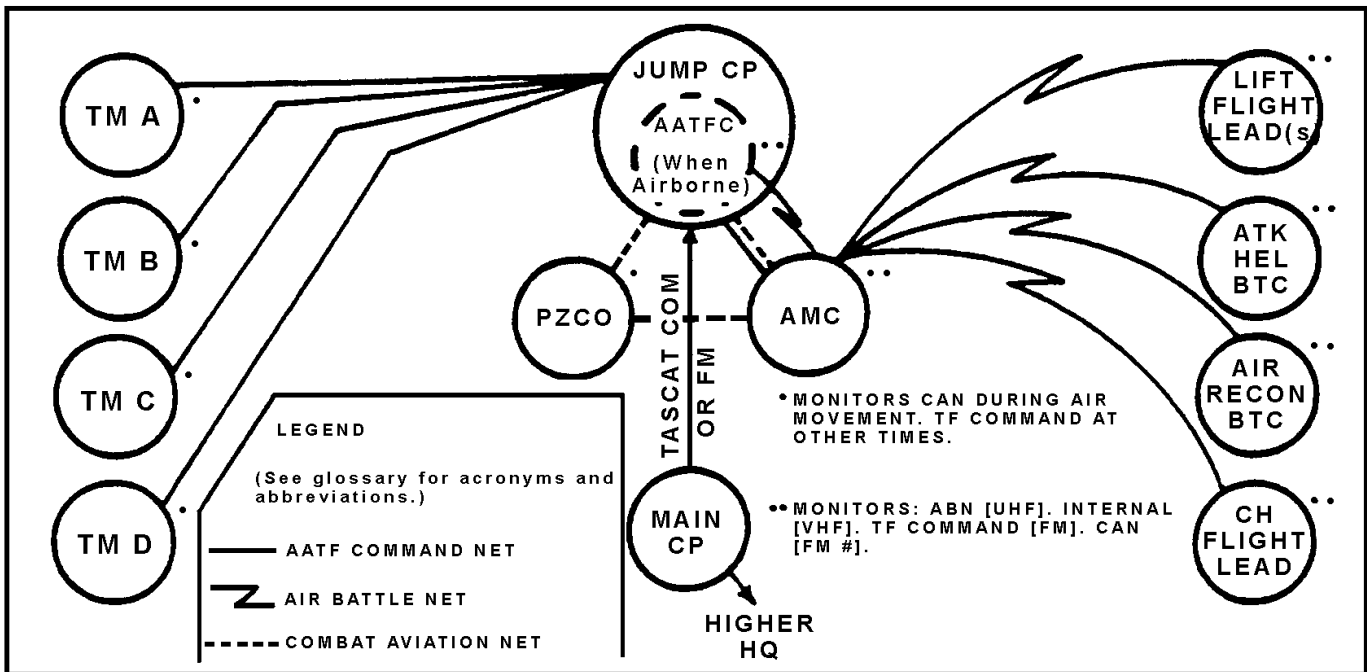
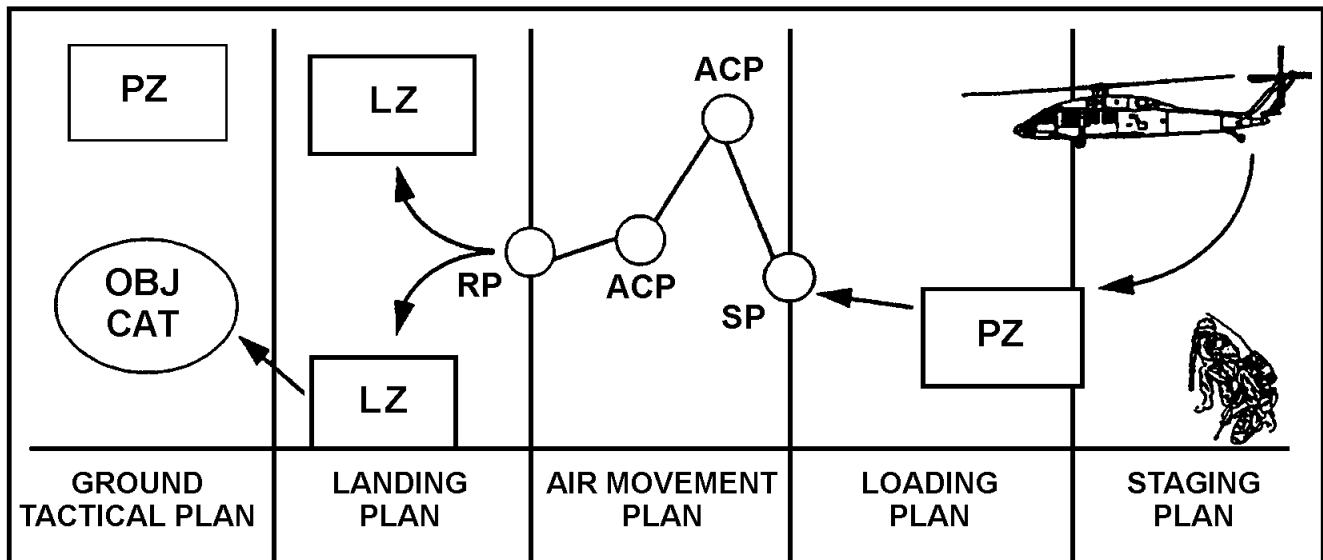

Figure 3-2. Air assault radio nets

3-7. AIR ASSAULT PLANNING STAGES

The successful execution of an air assault is based upon a careful analysis of the factors of METT-T and a detailed, precise reverse planning sequence. The five basic plans that comprise an air assault operation are the ground tactical plan, the landing plan, the air movement plan, the loading plan, and the staging plan. Air assaults are planned in reverse order, beginning with the ground tactical plan and working backwards to the staging plan. Reverse planning is imperative, as each successive planning step has an impact on the step that precedes it. The landing plan, for example, helps the air assault planners to determine the sequence and composition of lifts during the air movement phase. Figure 3-3 shows the reverse planning sequence.



LEGEND: See the glossary for acronyms and abbreviations.

Figure 3-3. Reverse planning sequence

a. Ground Tactical Plan. The foundation of a successful air assault is the ground tactical plan. All other air assault planning stages are based on the ground tactical plan. The ground tactical plan specifies actions in the objective area that will lead to accomplishment of the mission. The ground tactical plan addresses the following areas:

(1) Organization for combat. The mission, enemy situation, terrain, maneuver forces, and fire support assets all help air assault planners determine the task force organization for combat. Emphasis is placed on--

- Maximizing combat power in the assault to heighten surprise and shock effect. This is especially important if the AATF plans to land on or near the objective.
- Ensuring that the task force inserts enough force to accomplish initial objectives quickly. AATFs must be massed in the LZ and build up a significant combat power capability early to prevent being defeated by repositioning mobile enemy forces.
- Ensuring the AATFC properly allocates his CS and CSS assets to sustain the task force until follow on forces arrive.

(2) Fire support. The AATFC must consider relocating artillery if the LZ is out of range of the supporting artillery. Utility and cargo helicopters may be required to move the artillery. The amount of artillery available to support the air assault and the location of supporting artillery units are critical factors in determining the ground tactical plan and the subsequent plans of the air assault.

(3) Scheme of maneuver. The AATFC develops a scheme of maneuver to accomplish his mission and seize assigned objectives. Development of the scheme of maneuver must be done prior to development of the air assault. Occasionally the scheme of maneuver will be developed concurrently with the air assault. An example of this is when there are limited LZs. In this case it may be necessary to plan the scheme of maneuver around the landing plan. Scheme of maneuver development by the AATF headquarters will allow subsequent planning phases of the air assault to be accomplished. Development of the AATF ground tactical plan need not be complete to begin air assault mission planning. As a minimum, the AATFC must provide the following information for the AATF and aviation staffs to begin the air assault planning process. The ground scheme of maneuver must be known for air assault planning to begin. The AATF planners should not wait for the completed assault force OPORD to begin planning. When the general scheme of maneuver is approved by the assault force commander, the AATF staff and aviation units can begin air assault planning.

(4) Commander's intent. The AATFC must articulate early his intent for the air assault. Air assault planning can often begin after the AATFC issues his intent, even though the ground tactical plan may not be complete. The commander's intent for the air assault will allow the air assault planners to clearly understand the method and end state and begin to piece together the subsequent plans. Commander's intent for the air assault will include such things as whether the assault force will land on the objective or land near it and maneuver to it. The commander's intent for the air assault may include surprise as a critical element, which leads to the development of the fire support and SEAD plans. Intent will vary based on the factors of METT-T, but it is critical that the AATF planners receive the commanders intent as soon as possible after the mission is received.

(5) Air cavalry/attack helicopters in support of the ground tactical plan. Once the infantry is on the ground, the air cavalry and/or attack helicopters may switch roles. The AATFC may designate that at this time C² of the security assets change from the AMC to the ground force commander. During the ground fight the air cavalry and attack helicopters assist the assault force commander by providing reconnaissance in the vicinity of the LZs, destroying repositioning forces, destroying counterattacking forces, and calling fire. The shift in C² from the AMC to the assault force commander is critical, and must be planned and rehearsed in detail. It may occur that during an air assault with multiple lifts the cavalry and attack helicopters will support the air assault and ground fight (some elements will provide reconnaissance and security for the air assault and other elements will screen for the assault force). If this happens, synchronization of the attack and cavalry assets must be precise and detailed to eliminate confusion and to ensure that the flow of the air assault is not disrupted.

b. Landing Plan. The scheme of maneuver and ground tactical plan directly impacts on the selection of LZs, landing formation, and amount of combat power that must be assaulted into the LZ. The landing plan must be planned in conjunction with the development of the ground tactical plan. The landing plan must support the assault force commander's intent and scheme of maneuver. The landing plan outlines the distribution, timing, and sequencing of aircraft into the LZ.

(1) LZ selection. In coordination with the AMC and LNO, the AATFC selects primary and alternate LZs. The number of selected LZs is based upon the ground scheme of maneuver and LZ availability. The aviation planners advise the AATFC on LZ suitability. The considerations for selecting suitable landing zones are--

- Location. The LZ must be located in an area that supports the ground tactical plan of the AATFC. It may be located on the objective, close by, or at a distance. The factors of METT-T should be considered when selecting LZs.
- Capacity. The selected LZ must be big enough to support the number of aircraft the AATFC requires on air assault lifts.
- Enemy disposition and capabilities. The AMC must consider ADA locations and weapons ranges, and the ability of the enemy to reposition ground forces to react to the air assault. LZ selection must involve the AATF S3, the AMC, and the S2s from the AATF and aviation task force. S2s provide intelligence information that will affect the selection of LZ locations.
- Unit tactical integrity. Squads must land intact in the LZ, and platoons must land in the same serial. This ensures fighting unit integrity during the air assault.
- Supporting fires. LZs must be selected that are in the range of supporting fires (artillery, CAS, naval gunfire).
- Obstacles. LZ selection must include existing obstacles on the LZ as well as reinforcing. LZs should be selected that are beyond enemy obstacles.
- Identification from the air. The LZ should be identifiable from the air if possible.

(2) Single or multiple landing zones. The decision to use a single or multiple LZs is based upon the ground tactical plan and the AATFC's intent. However, there are advantages to using single or multiple LZs. The single LZs--

- Make controlling the operations easier.
- Require less planning and rehearsal time.
- Centralize any required resupply operations.
- Concentrate supporting fires on one location.
- Provide better security on subsequent lifts.
- Mass more combat power in a single location.
- May make the detection of the air assault by enemy units more difficult because the air assault operation is confined to a smaller area of the battlefield.

The multiple LZs--

- Do not group the entire force in one location.
- Force the enemy to fight in multiple directions.
- Allow rapid dispersal of ground elements to accomplish tasks in separate areas.
- Make determining the size of the assault force difficult for the enemy.

(3) Air cavalry/attack helicopters in support of the landing plan. During the landing plan the air cavalry and/or attack helicopters will provide overwatch of the LZs, conduct a reconnaissance of the egress flight routes, call for fire (if designated to do so), and set up a screen for supporting the assault force commander during the ground tactical plan. The AMC must be certain that the missions of the attack and cavalry aircraft are synchronized with the assault helicopters.

c. Air Movement Plan. The air movement plan is based on the ground tactical and landing plan. It specifies the schedule and provides the instructions for the movement of troops, equipment, and supplies from the PZ to the LZ. It provides coordinating instructions regarding air routes, ACPs, aircraft speeds, altitudes, formations, and fire support. The AATFC develops the air movement plan in conjunction with the AMC, LNO, and flight lead. The air movement plan results in the production of the air movement table.

(1) Selection of flight routes is always based upon the factors of METT-T. The AATF staff and the AMC consider the location of friendly troops, enemy disposition, air defense systems, terrain, and the locations of the PZ and LZ to select the best flight route. Flight route selection should be accomplished by the AATF staff, to include the S3 and S2, the AMC (or LNO), and flight lead. Selected flight routes should always be laid over the enemy situational

template produced by the S2 to ensure that a flight route is selected that best avoids known or suspected enemy positions.

- (2) The AATF staff and the AMC must select primary and alternate flight routes. Alternate flight routes are selected to provide the assault force with a preplanned, precoordinated method of moving from the PZ to LZ if the primary route becomes compromised.
- (3) Flight routes that pass through adjacent unit sectors must be coordinated and approved by the adjacent unit to avoid potential fratricide.
- (4) When selecting flight routes, the AMC and AATF staff must consider the following factors:
 - (a) **Airspace management.** Flight routes are designed to ensure that aviation task force maneuver space is free from friendly fire. Flight routes must be planned that do not conflict with artillery or ground maneuver forces that may be operating. They should not overfly friendly artillery locations. Flight routes must be coordinated with all forces to ensure prevention from fratricide.
 - (b) **Support of the landing plan.** Flight routes should provide for approach to and departure from the LZ so as to minimize the ability of the enemy to see the LZ. It must support the landing plan.
 - (c) **Enemy capabilities.** To minimize enemy observation and acquisition, flight routes should make maximum use of terrain, cover, and concealment and avoid known or suspected enemy positions.
 - (d) **Fire support.** Flight routes should be selected that are within the range of friendly fire support assets.
 - (e) **Distance.** To reduce aircraft exposure time and the ability of the enemy to observe the air assault, flight routes should be as short as possible.
- (5) Air cavalry/attack helicopters can be used in support of the air movement plan. During the air movement phase the air assault security forces provide reconnaissance and security for the assault helicopters. This may be accomplished in a number of ways. For example, prior to the assault helicopters departing the PZ, the attack/cavalry aircraft can conduct a reconnaissance of the ingress route and set up overwatch positions along the route to provide security, or the attack/cavalry aircraft can fly ahead of and/or behind the assault helicopters to provide security.

d. Loading Plan. The AATFC bases the loading plan on the air movement plan and the ground tactical plan. The loading plan ensures that troops, equipment, and supplies are loaded on the correct aircraft. It establishes the priority of loads, the bump plan, and the cross loading of equipment and personnel. Detailed load planning will ensure that the aatf arrives at the LZ configured to support the ground tactical plan. A bump plan ensures that essential troops and equipment are loaded ahead of less critical loads in case aircraft are lost during the air assault. Planning for the loading plan must include the organization and operation of the PZ, the loading of aircraft, and the bump plan.

(1) **Pickup zone selection.** The first step in the loading plan is selection of a suitable PZ or PZs. Primary and alternate PZs should be selected during this process. Multiple primary PZs may be necessary to facilitate a smooth flow of personnel and equipment. The AATFC may elect to have separate LZs for troops and equipment (heavy and light PZs). The heavy PZ contains any external loads that will be used for the air assault, and the light PZ is where the troops will be lifted from. Selection of PZs is based on METT-T, the intent of the AATFC, the location of the assault forces in relation to the PZ, and the size and capability of available PZs. The AATF staff, AMC, and LNO select suitable PZs that support the intent of the AATFC. PZ selection should be based on the following considerations:

(a) **Number.** The AATFC specifies the number of PZs based on the factors discussed

above. Multiple PZs may have an advantage over single PZs in that they avoid concentrating the force in one location. However, multiple PZ operations require detailed and precise planning.

(b) Size. Each PZ should accommodate all supporting aircraft at one time.

(c) Proximity to troops. PZs should be selected that are close to the troops being lifted, so they are not required to travel a long distance.

(d) Accessibility. PZs should be accessible to vehicles that move support assets and infantry. However, PZs should be located in an area that limits traffic from vehicles or personnel that are not directly involved in PZ operations.

(e) Vulnerability to attack. PZs should be masked by terrain from enemy observation.

(f) Conditions. PZ selection needs to take into account the surface conditions of the area. Excessive slope, blowing dust or sand, blowing snow, and natural and man-made obstacles all create potential hazards to PZ operations.

(2) Pickup zone control. Once the AATFC selects the PZ, the PZCO organizes, controls, and coordinates the PZ operation. To establish control over the PZ, the PZCO forms a control group consisting of PZ control teams, support personnel, air traffic services personnel (if available), and security personnel.

(3) Aviation involvement. The assault helicopter unit must ensure that aviation expertise is present on the PZ. The LNO, or another designated representative, should locate with the PZCO during the PZ selection, set-up, and execution phase. The aviation representative provides guidance on the PZ setup, taking into consideration aircraft factors. For example, the PZ landing direction may change if the wind changes significantly. Additionally, the aviation representative can offer advice on surface conditions and their effect on helicopter operations.

(4) Pickup zone communications. Communications must be by the most secure means available. PZ operations may be conducted under radio listening silence to avoid electronic detection. This requires detailed planning. If under radio listening silence, it is imperative that aircrews remain on schedule to allow the PZCO to keep a smooth flow of troops from the PZ. PZ communications will be accomplished on the established FM PZ control net, with transmissions kept to a minimum.

(5) Pickup zone marking. The PZCO directs the marking of the PZ. PZ marking must be done so that the PZ is identifiable from the air. Far and near recognition signals are needed, especially at night, to allow the pilots to orient on the PZ quickly. Touchdown points must be clearly marked. The PZCO must ensure that no other lighting is on the PZ. Extraneous lights in the area of the PZ will cause confusion to the aircrews and result in slow loading times and delayed air assault times.

(6) Disposition of loads on the pickup zone. Personnel and equipment must be positioned on the PZ to conform with the landing formation. Flight crews must understand the loading plan on the PZ, and be prepared to accept troops and equipment immediately on landing. PZ sketches depicting location of loads in the PZ will assist flight crews in loading troops and equipment quickly once the aircraft arrive in the PZ. Flight crews should be provided a PZ diagram. Figure 3-4 shows an example of a PZ diagram. Figure 3-5 shows the duties of the PZCO and the aviation LNO during the execution of the PZ operations.

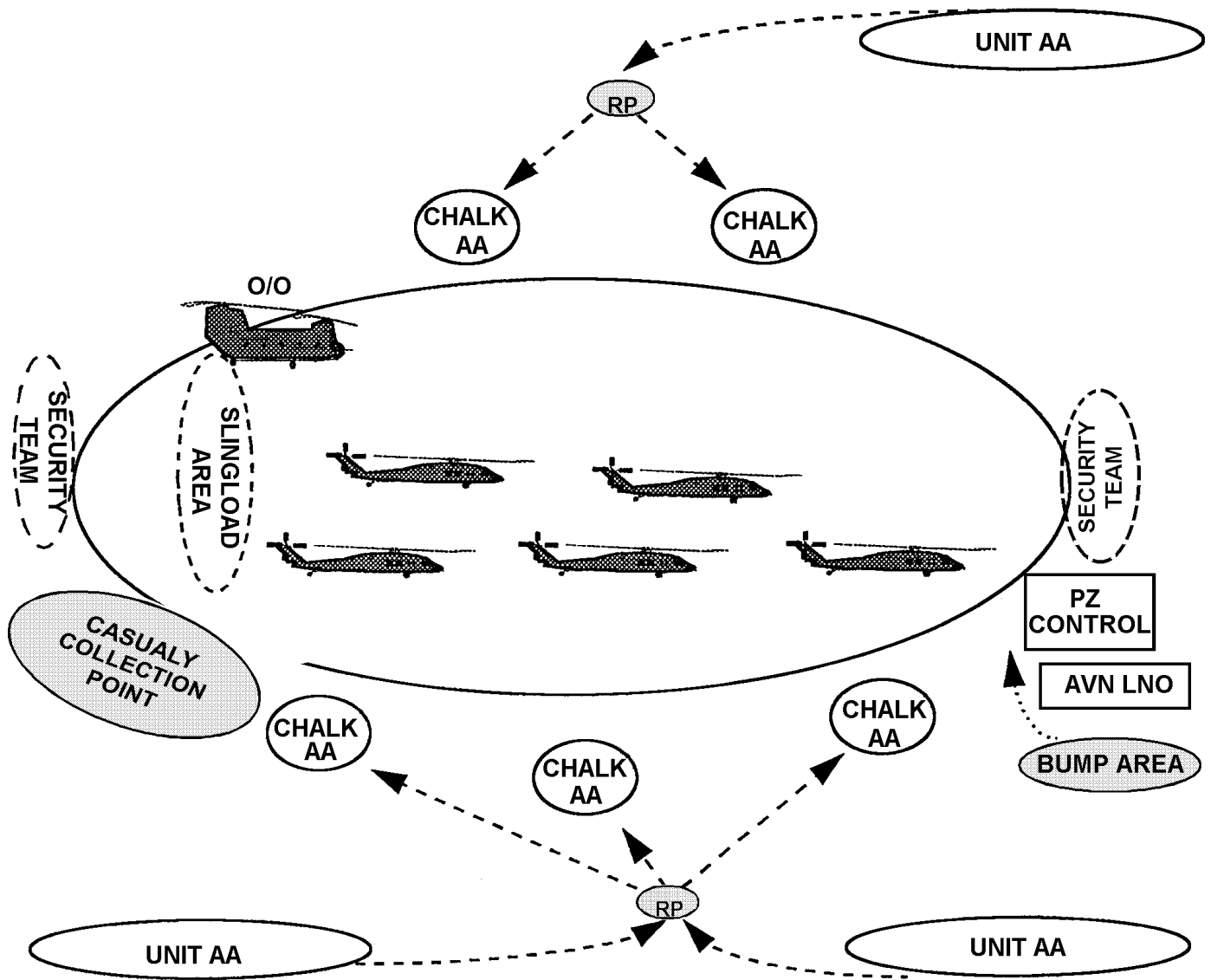

LEGEND: See the glossary for acronyms and abbreviations.

Figure 3-4. PZ operations

PZ CONTROL OFFICER

- Forms PZ control group
- Establishes communication
- Plans and initiates fire support (PZ security)
- Plans and initiates PZ security
- Clears PZ of obstacles
- Marks the PZ (never use blue/green chem lights)
 - PZ requirements depend on type and number of aircraft and is based on minimum acceptable distance between aircraft*
- Responsible for the execution of the bump plan
- Established CASEVAC/sling load areas
- Overall responsibility for the successful conduct of the PZ

AVIATION LNO

- Assist in the control of aircraft arrival to PZ
- Advises PZCO of changes due to aircraft problems
- Monitors the CAN and aviation internal nets
- Collocate with the PZCO

* Minimum acceptable distances for the establishment of PZ pick-up points are as follows: For day operations, the external load distance is at least 100 meters for CH-47 aircraft and 50 meters for UH-60 aircraft. At night, the external load distance is at least 150 meters for CH-47 aircraft and 75 meters for UH-60 aircraft. These are minimum separation distances between the internal load PZ points and the external load PZ points.

LEGEND: See the glossary for acronyms and abbreviations.

Figure 3-5. PZCO and LNO PZ responsibilities

(7) Air cavalry/attack helicopters in support of the loading plan. During the loading phase, the attack and cavalry aircraft can assist the AATFC by providing overwatch of the PZs and by conducting a route reconnaissance of the air assault flight routes.

e. Staging Plan. The staging plan is based on the loading plan and prescribes the proper order for movement of personnel and aircraft to the PZ. Loads must be ready before the aircraft arrive at the PZ. During mission planning, the PZCO determines the time required to set up the PZ and selects times (based upon the air assault H-hour) that the PZ control group will establish the PZ. During the staging plan, the aviation unit is conducting mission planning, orders, and necessary checks to ensure that the mission times are met once the air assault is executed. During the staging plan, the aviation unit should be focusing on mission planning, precombat checks and inspections, FARP operations, and routes to the PZ.

(1) Mission planning. Mission planning includes the coordination between the AATF and the AMC, development of the aviation OPORD, issuing of the OPORD and AB, and rehearsals.

(2) Precombat checks and inspections. During the staging plan, the aircraft are prepared for the operation. Unit commanders ensure that aircraft have sufficient fuel,

COMSEC fills are loaded and equipment is operational, cargo hooks are operational, and aircraft log books and keys are accessible. They also ensure that aircraft are prepared to accept the loads for the air assault (internal or external).

(3) Forward arming and refueling point operations. If a FARP will be used during the air assault mission, it must be planned and positioned during the staging plan. Consideration should be given to site selection, time required to be operational, travel time, safety inspection criteria, and night set-up considerations (if applicable).

(4) Routes to the pickup zone. The AMC must select flight routes to the PZ that allow the aircraft to arrive at the PZ on time in the proper landing direction and configuration to accept loads.

3-8. AIR ASSAULT PLANNING

The success of any mission depends largely on the planning process. This section is designed to assist in the planning of the air assault operation. The time available for planning an air assault operation will vary. However, enough planning time must be allotted for detailed planning and synchronization to occur. For company level air assaults, a minimum of 24 hours should be allotted for air assault planning. For battalion and brigade level air assaults, 72 hours should be allotted for air assault planning. Air assault operations involving small numbers of aircraft and personnel (LRSD, scout insertions) may not require as much planning time. These missions should be able to be accomplished successfully with at least 6 hours planning time. These planning times are recommended and are based upon the ability to thoroughly plan and synchronize all air assault assets. Air assaults may be conducted with less time to plan than this, but the AATFC must understand that a much greater risk is assumed with a condensed planning time. Figure 3-6 shows the air assault planning process.

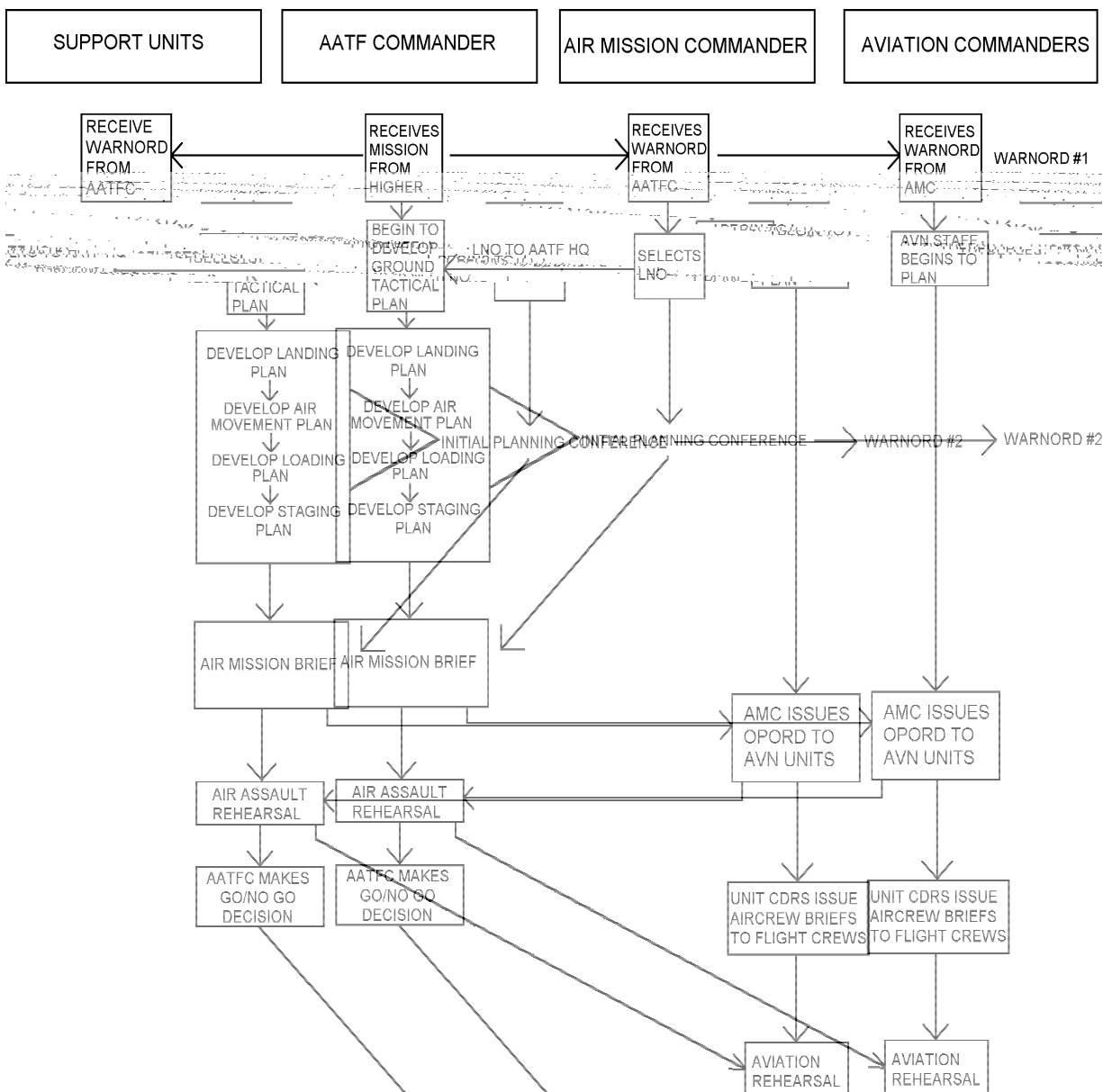

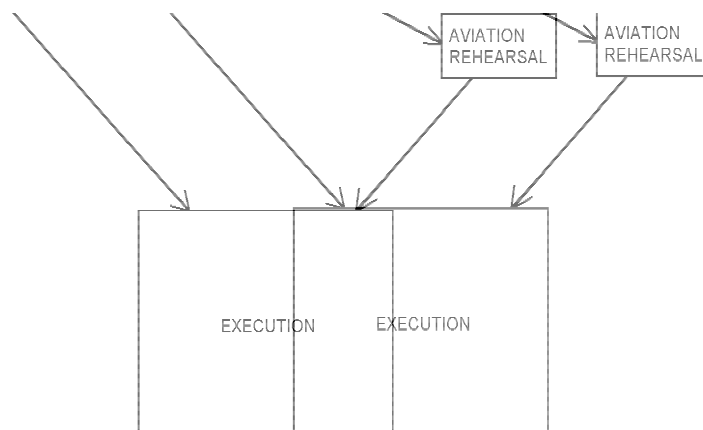

LEGEND: See the glossary for acronyms and abbreviations.

Figure 3-6. Air assault planning diagram

a. Warning Order. Air assault planning begins when the aviation unit receives a WARNORD from higher headquarters on the upcoming air assault mission. The WARNORD should specify who the AATFC is. This will allow the aviation commander to dispatch an LNO early to the AATF headquarters and prepare the aviation unit for the initial planning stages of the air assault.

b. Initial Planning Conference. The IPC is the first meeting between the AATF staff and the aviation unit. The aviation unit should be represented by the AMC, LNO, battalion S2, battalion S3, flight leads, and additional members of the battalion that the AMC selects to bring. The location of the IPC is at the AATF headquarters or at a location selected by the AATFC. The IPC should occur early in the air assault planning process. When the AATFC has a general idea of the intent and ground tactical plan scheme of maneuver, the planning can start. The IPC is covered in Appendix B.

c. Commander's Critical Information Requirements. At IPC, the AATFC must establish his CCIR.

CCIR: Information required by the commander that directly affects his decisions and dictates the successful execution of operational or tactical operations. CCIR will normally result in the generation of three types of information requirements: priority intelligence requirements (PIR), essential elements of friendly information (EEFI), and friendly force information requirements (FFIR). [FM 101-5-1](#), *Operational Terms and Graphics*, Drag Version, 15 November 196. (Estimated publication date is August 1997.)

The AATFC must establish and define his CCIR early in the air assault planning process, as this will result in decision points that will affect the air assault. Abort criteria for the air assault results from the decision points established by the CCIR. Examples of CCIR in relation to the air assault are--

(1) Priority intelligence requirements.

- (a) What are the locations of air defense systems that can affect me at night and range the PZ, LZ, and routes?
- (b) What ground forces have the ability to reposition and influence the LZ?
- (c) Is the LZ in direct fire range of any enemy forces?

(2) Friendly force information requirements.

- (a) The air assault requires 12 UH-60s and 3 CH-47s. As a minimum, we can execute with 10 UH-60s and 2 CH-47s. The commander must be notified if UH-60 availability drops below 10 or CH-47 availability drops below 2.
- (b) Weather must be greater than the established minimums not later than 12 hours

prior to the air assault. The commander must be notified if weather is less than established minimums at H-12 hours.

(3) Essential elements of friendly information.

(a) Preparation, marking, and setup of the PZ.

(b) Air assault rehearsals.

The result of the CCIR is that the AATFC must establish decision points that affect the air assault. If and when these decision points are reached, they require the AATFC to do one of three things--abort the mission, change the scheme of maneuver, or accept risk and continue as planned.

d. The Air Mission Briefing. The air mission briefing is the final coordination meeting of key air assault personnel. The AMB is designed for key AATF personnel to brief the plan to the AATFC. AMBs are not planning sessions. The planning for the air assault should be complete by this time. The AMB is a coordinated staff effort that is the culmination of the air assault planning process. Once the AMB is complete, the AATFC approves the air assault plan. The approval of the air assault plan by the AATFC signifies the "good idea cut off point." For the aviation assault unit, the minimum attendees should be the AMC, aviation S3, aviation S2, serial commanders, flight leads, and the LNO. The AMC should brief the aviation portion of the AMB. [FM 90-4](#) discusses the format for the AMB.

e. Aviation Orders Development. Throughout the air assault mission planning process, the aviation unit is producing the aviation OPORD, conducting ABs at company and serial level, and conducting a rehearsal of the aviation portion of the air assault.

(1) Operation order. The aviation staff prepares an OPORD for the aviation portion of the air assault. The OPORD is approved by the AMC, and is planned in parallel with the air assault mission planning process. The OPORD discusses the aviation mission, and includes all members of the aviation portion of the air assault, to include the cavalry and attack helicopter assets. The OPORD is briefed to the commanders of the assault, medium lift, cavalry, and attack helicopter commanders involved in the air assault. Aviation task force staffs must pay attention to the 1/3-2/3 rule during the orders process. It is not always possible to follow a strict 1/3-2/3 planning timeline. In this case the use of WARNORDs becomes critical. WARNORD must be issued early and often to keep the company commanders and flight crews abreast of the current air assault plan. Maximum time must be provided to subordinate aviation commanders so that those aircrews executing the mission have sufficient mission preparation time.

(2) Aircrew brief. Aviation unit commanders brief the flight crews that will execute the air assault mission. This briefing is called the AB and covers the essential flight crew actions and aviation planning necessary to successfully accomplish the mission. ABs are briefed by the unit commander or serial commander. However, the aviation battalion staff should be available to provide expertise and assistance (the S2 may brief the enemy situation). The AB is the critical portion of the aviation unit's piece of the air assault. Flight crews must fully understand the mission and execution for the air assault to be executed successfully. An example of an AB is included in Appendix C.

(3) Rehearsals. The aviation battalion must conduct a rehearsal to synchronize all elements of the air assault. It must conduct rehearsals as part of the AATF. The aviation rehearsal focuses on synchronizing the aviation assets involved in the air assault. It should have a representative from the lifted unit and a representative from the AATF FSE. The type of rehearsal conducted is dependent upon METT-T. However, it must be focused on synchronizing the assets involved and coming up with contingencies for the most likely events that can affect the plan.

3-9. AIR ASSAULT SECURITY

Air assault security operations provide force protection for air assault operations. Air assault security encompasses the entire range of planning and operations conducted to protect the AATF as it moves

from the PZ to the LZ. It is planned and executed as an integral part of the air assault operations and is planned by the AATF headquarters. Air assault security is a highly synchronized operation often involving many different types of units executing reconnaissance, security, electronic warfare, and other missions in support of the AATF. A security force will precede the assault force on the route (based on METT-T), ensuring that the route is secure for the lifting aircraft.

a. Units Involved in Air Assault Security.

(1) Air cavalry. Reconnaissance and security are vital components of air assault security operations. Air cavalry units play a major role in these operations. Missions for the air cavalry include screening, route reconnaissance of air axes and flight routes, PZs, and LZs, providing suppressive fire, and coordinating passage of lines. METT-T determines how these units are actually employed. If attack helicopters are not available, air cavalry units may be required to perform attack missions within the limits of their capabilities.

(2) Ground cavalry. Ground cavalry units may also be employed in the air assault security role. Missions for the ground cavalry units include PZ security, reconnaissance of routes, security of FARPs, and passage of lines coordination.

(3) Attack helicopters. AHBs or companies are capable of performing the missions of the air cavalry units and can be expected to conduct these missions when air cavalry is unavailable. The attack helicopter units also conduct overwatch and screening of the air assault force during movement along the flight route from the PZ to LZ, providing protection from enemy ground fire or attacks. They can provide suppressive fires, SEAD, and may be used as a reserve force to counterattack threats to the AATF. Attack helicopters may also be integrated in the scheme of maneuver for the ground tactical phase, where they may be used to conduct screen or guard missions, hasty attacks, or other missions in support of the AATF.

(4) Military intelligence units. Corps MI units equipped with UAVs can provide R&S for air assault operations. Corps LRSD teams can provide similar intelligence products. UAVs equipped with day television or FLIR sensor packages are capable of reconnoitering flight routes, LZs, and objectives before and during air assault operations.

b. Air Assault Security Planning. Although air assault security is performed by the air cavalry or attack units, the AMC will control the operations of these assets. However, the method of employment and maneuvering of the security elements should be left to the commander of the security element.

(1) Scheme of maneuver development. During air assault planning the security element commander will develop his scheme of maneuver to provide the best, most responsive support for the AATF. The plan developed by the security element will be planned in conjunction with the air assault to ensure that it supports the air assault phases. Additionally, the security plan must be briefed to the AATFC as part of the AMB. The AATFC is the final approval for the scheme of maneuver to be used by the air assault security element. (An example of a scheme of maneuver developed by the security element commander is the security teams/companies/troops may fly ahead of the air assault and set up overwatch positions in the vicinity of the route and LZ; they may travel behind the lifting helicopters and be prepared to respond to any threat that is encountered.) The security team commander will decide, based on METT-T, the best way to employ the cavalry or attack aircraft. Once the scheme of maneuver is developed, the AMC will brief the AATFC, who will approve the air assault security plan.

(2) Airspace deconfliction. The AMC and the aviation staff will be responsible for coordinating the airspace during the air assault. They will ensure that an adequate plan is developed to deconflict the lifting helicopters, the cavalry, and attack helicopters. The AMC must ensure that all aviation commanders understand the airspace management plan prior to executing the air assault.



CHAPTER 4

AIR MOVEMENT OPERATIONS

4-1. GENERAL

Air movement operations are those operations designed to move supplies, equipment, and personnel. Air movement operations are not conducted in direct contact with the enemy and may or may not include other members of the combined arms team. Examples of air movement operations include--

- Repositioning of forces on the battlefield.
- Logistics resupply operations.
- External load operations.
- Movement of liaison personnel.
- Downed aircraft recovery.
- Noncombatant personnel evacuation operations.

4-2. UTILITY AND CARGO HELICOPTERS IN AIR MOVEMENT OPERATIONS

a. Moving Personnel.

(1) Large troop movement. Utility helicopters may be assigned missions to move units on the battlefield for the purpose of repositioning forces. UH-60s and CH-47s can be expected to conduct troop movement on the battlefield. Planning for this operation should be accomplished as if it were an air assault mission. The time required to plan the air movement will be less, but the principles and steps of air assault planning are the same. Chapter 3 discusses planning and coordination for air assault operations. The air movement of large troop units should be planned using the same principles. The difference is that in air movement operations the force is not being moved into a combat operation and will not use all of the combined arms assets that would be included in an air assault operation.

(2) Passenger transport. Utility helicopters, primarily UH-60s, can be expected to conduct air movement of personnel. This mission differs from

large troop movements in that passenger transport missions will normally be accomplished by a single aircraft. Passenger transport missions include transporting LNOs, orders groups, commanders and staffs, chaplain support missions, and any other mission involving movement of passengers. While relatively simple to execute, this mission requires thorough planning and preparation. Air movement planning must be the same as the planning for any other mission the utility and cargo helicopter unit must accomplish. Air movement planning considerations listed in this chapter should be adhered to in order to accomplish passenger transport missions.

b. Moving Supplies. Movement of supplies and equipment on the battlefield is a critical mission for the utility and cargo helicopter unit. The speed and mobility of utility and cargo helicopters make them an invaluable asset to the commander for transporting priority supplies throughout the AOs. With the lift capability of the CH-47, air movement of large quantities of supplies not only gets equipment to its destination rapidly, but also frees up ground transportation assets. Logistics will be moved by UH-60 and CH-47 throughout the AOs. CH-47s move supplies forward from the corps support area to the DSAs. CH-47s task organized to the division and divisional UH-60s move supplies from the DSA to BSAs and down to the battalion task force level (see Figure 4-1). Logistics resupply operations are further discussed by class of supply.

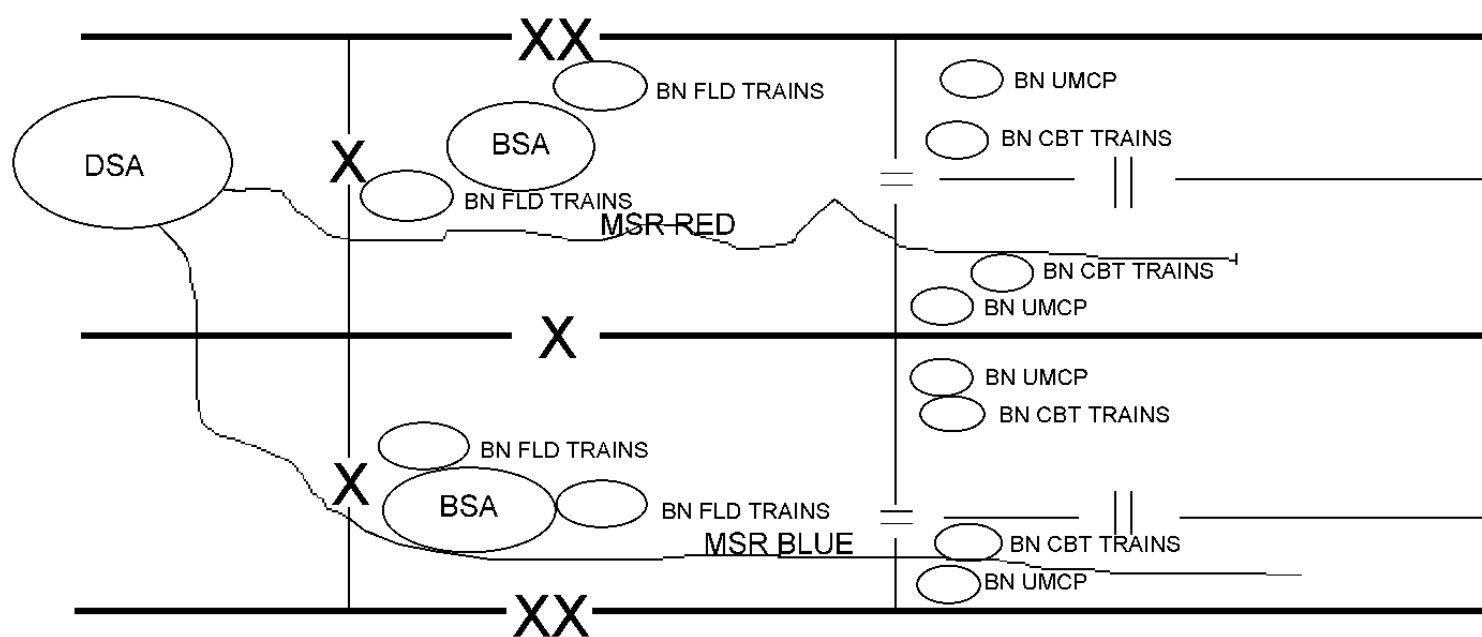

Legend: See the glossary for acronyms and abbreviations.

Figure 4-1. Division logistics structure

(1) Class I (subsistence items). Utility helicopters can expect to move large quantities of class I on the battlefield. CH-47s from the corps medium lift battalion will be used to move class I supplies from the COSCOM forward to the DSA. Utility helicopters (UH-60s and CH-47s), operating under division control, will move class I from the DSA forward to the BSA and, in some instances, as far forward as battalion combat trains. During hot weather operations, aircraft may move water and ice forward to battalion combat trains. LZs will be established at DSAs and BSAs specifically for class I.

(2) Class II (organizational clothing/individual equipment). Utility

helicopters may find themselves moving class II on an occasional basis. Replenishing stockage levels of class II may become a mission for the CH-47s in the corps. These aircraft will move class II supplies forward from the COSCOM to the DSA. Air movement forward from the DSA will most likely be accomplished by ground.

(3) Class III (petroleum, oil, and lubricants). Utility and cargo helicopters offer a unique capability for moving class III. Fuel can be transported rapidly around the battlefield. The utility and cargo helicopter's function in moving class III is a part of forward arming and refueling operations.

(a) Forward area refueling equipment or advanced aviation forward area refueling system. Utility and cargo helicopters can externally transport the FARE system, AAFARS, and 500-gallon fuel blivets. A complete FARE system is capable of providing up to six aircraft refueling points, and the AAFARS can provide up to four refueling points. Air moving a FARP forward allows attack and cavalry aircraft to rapidly refuel, rearm, and continue the attack or reconnaissance mission. UH aircraft can also resupply forward FARPs with class V, allowing a full refuel and rearm capability. Once the FARE system or AAFARS is emplaced, the utility helicopters can continue to resupply the FARP by externally moving fuel blivets. Once FARP operations are complete, the utility aircraft are used to extract or reposition the FARP to a new location. UH-60s can move up to two fuel blivets, while CH-47s can transport five fuel blivets externally. The use of utility and cargo helicopters to transport the FARE system offers some advantages, while there are also disadvantages to this method. Advantages for using utility and cargo aircraft for transport of the FARE/AAFARS are--

- Minimum LZ time for the aircraft moving the system.
- Ability to transport personnel internally (CH-47 only). The ability to move internal passengers in the UH-60 may be limited due to the weight of the external loads, particularly the fuel blivets.
- Increased flexibility to use aircraft on other missions (no aircraft modification required).
- Increased flexibility to use backup aircraft if the primary has mechanical difficulties.
- Ability to jettison the load if the situation dictates.

Disadvantages to using utility and cargo aircraft for transport of the FARE/AAFARS are--

- Higher flight altitude.
- Slower speeds.
- Reduced aircraft maneuverability.
- Reduced fuel load (for UH-60s). For the UH-60, it may be necessary to reduce fuel on board to lift the external loads (fuel blivets). In this case, mission endurance will be decreased.

(b) UH-60/CH-47 forward arming and refueling point operations. UH-60s and CH-47s can be used for rapid refueling operations for attack and cavalry aircraft. Not all aircraft can accomplish this mission. CH-47s and UH-60s performing this mission must have auxiliary fuel tanks.

Commanders must decide early if they want to use the utility and cargo aircraft for this type of FARP so that the appropriate preparation of the aircraft can be made. Appendix E covers the use of these aircraft to conduct refueling operations.

(4) Class IV (construction and barrier material). Class IV resupply is a critical mission for utility helicopters, particularly during a defensive operation. Ground forces preparing for a defense will use a tremendous amount of class IV, particularly wire. Utility helicopters are invaluable in moving these supplies forward from the DSA and BSA to task force class IV points, where it will be used for battlefield preparations. As in all air movement operations, resupply of class IV by air allows for rapid preparation of defensive sectors.

(5) Class V (ammunition). In high tempo combat operations we can expect to expend large amounts of ammunition. Utility helicopters play a vital role in keeping the force resupplied with ammunition. Ammunition is normally stored in a division ASP. High usage items will be moved forward to temporary ATPs. Movement of ammunition by helicopters can be broken down into the following areas:

(a) Ammunition supply point to ammunition transfer point. Air movement from ASP to ATP is normally done externally. Using the speed and lifting capability of the utility helicopter, the DISCOM commander will use these assets to rapidly move ammunition forward. Using UH aircraft allows for 24-hour operations, keeping the force supplied with ammunition.

(b) Emergency resupply. Emergency class V resupply is normally done from the ATP forward to a unit in contact or who has recently broken contact. This operation is critical for the utility unit in that rapid resupply is necessary for the ground forces to continue the attack. However, consideration must be given to the friendly and enemy situation, A²C² measures established, friendly weapons control status, and call signs and frequencies of the receiving unit before executing this mission. Time is essential during an emergency class V resupply. Anticipation of this mission by the utility helicopter battalion staff can result in prior coordination and ultimately quick response time.

(c) Resupply of aviation assets. As with moving class III forward to jump FARPs, utility aircraft may also be used to bring forward ammunition to the FARPs. UH-60s will be given missions to transport Hellfire missiles, 30mm ammunition, 2.75-inch rockets, and Stinger missiles forward from main FARPs and ATPs to sustain the rapid tempo of attack helicopter and air cavalry operations.

(6) Class IX (repair parts). The use of UH-60s and CH-47s to move repair parts is critical to the success of the ground force battle. CH-47s at corps level can move class IX parts forward from the COSCOM to the DSA. Movement of class IX can be done either internally or externally. Aircraft operating under division control (UH-60s and CH-47s) can expect to move class IX repair parts forward from the DSA to the BSAs. Aircraft may also move critical repair parts past the BSAs direct to the task force UMCPs. Movement of critical class IX repair parts is a vital mission for utility helicopters. Operating day and night, these aircraft can provide the ground commander with parts that will enable

him to fix combat systems.

(7) Resupply of air assault forces. Air assault forces normally go into an LZ with only the minimum essential supplies (normally class V and class I, water). Utility and cargo helicopters must be prepared to follow up an air assault with resupplying the assault forces. Lifting aircraft must be prepared to conduct rapid refueling operations and return to a designated PZ to load with critical supplies and await for the designated launch time. The aviation battalion staff must include resupply of air assault forces as part of the planning of air assault operations.

c. Air Movement Responsibilities.

(1) Sending unit. The unit that is preparing the loads (internal or external) to be air moved is responsible for all facets of PZ operations. The responsibilities of the sending unit include preparation of the PZ (marking, clearing, communications), rigging of external loads, prioritizing loads, and tracking loads (where the load is going, and what the load consists of). The sending unit also provides the flight crew with the correct destination for the loads (LZ location, frequency, call sign, marking, POC).

(2) Moving unit (aviation unit). The aviation unit that will move the loads is responsible for ensuring the load is safe to fly and moving the cargo (internal or external) to the correct location. The moving unit also notifies the receiving unit if any changes are made to the established plan.

(3) Receiving unit. The unit that will accept the loads (internal or external) to be air moved is responsible for all facets of LZ operations. The responsibilities of the receiving unit include preparation of the LZ (clearing, marking, signaling, communications) and derigging the loads and loading the rigging material for backhaul, if required.

4-3. AIR MOVEMENT PLANNING CONSIDERATIONS

Air movement operations require detailed planning to accomplish successfully. For air movements of large troop formations, planning should be accomplished as if it were an air assault. Chapter 3 outlines air assault mission planning. Mission planning for general support missions, passenger transports, and logistics resupply missions requires detailed planning also. These missions can present a high level of risk. Often these missions are accomplished by single aircraft, and the distances involved, particularly for corps aviation aircraft, may be great. Corps utility and cargo aircraft will find themselves working beyond the range of communications from their parent organization. Mission details received by the utility and cargo helicopter battalion may be sketchy. Planning considerations for utility and cargo aircraft to conduct an air movement mission are listed below. Battalion staffs must consider these factors before sending aircraft out on small scale air movement operations.

a. Logistics. Aircraft conducting air movement operations may be a long distance from their parent organization. Consideration must be given to where these aircraft will receive fuel and maintenance support if needed. Coordination with adjacent aviation units can be accomplished so that aircraft can refuel at other units' FARPs. This will allow the aircraft to continue their mission and increase station time as they do not have to travel a long way to return to their own FARP. Additionally, when

under the control of the DISCOM, it is possible for the DSA to provide fuel. Battalions sending aircraft to conduct mission in support of the DISCOM should arrange for the DSA to provide fuel for their aircraft.

b. Command and Control. A set C² relationship must exist and the aircrews conducting the mission must understand what that relationship is. When sent on an air movement mission, it is essential that a POC be provided to the aircrews. Since the aircraft may be operating out of communications range of the parent organization, it is imperative that the aircrew know who to contact at the supported unit if there are mission changes or if they need support.

c. Army Airspace Command And Control. Aircrews conducting air movement missions must understand and comply with the airspace structure that is currently active. It will be published in the ACO. Adherence to the airspace structure is imperative, as it reduces the risk of fratricide. Utility helicopter battalions must know what airspace structure the aircraft will use to track aircraft location and mission status. A more detailed discussion of A²C² and the ACO can be found in [FM 100-103](#) and [JP 3-56.1](#).

d. Intelligence. Aircraft operating on air movement missions present a unique challenge for the utility battalion S2. Often these aircraft will operate across a large area of the battlefield. Corps aviation assets may push forward and support divisions, perhaps more than one division within the corps simultaneously. The S2 must recognize this and use all available assets to provide the aircrews with a detailed enemy situation. The S2 must evaluate potential threats that may effect the aircrews and recommend changes to their scheme of maneuver for them to accomplish their mission and avoid potential threats. For the S2 of the utility helicopter battalion, this may be the most difficult challenge he must face. Tapping in to other intelligence sources (such as aviation brigade S2, ground brigade S2s, Division G2s) will allow the S2 to provide an accurate intelligence update to the flight crews conducting an air movement.

e. Fire Support. For large scale troop movements, fire support should be planned. The assault battalion should be prepared to respond to any threat with quick, responsive fires. Working with the supported unit FSO targets can be developed to support the air movement. For small air movement operations, fire support will probably not be planned. However, aircrews should understand how to contact fire support assets if necessary. Aircraft conducting air movements must know the locations of friendly artillery that could effect their missions and adhere to the airspace structure to avoid fratricide.

f. Communications. Communications present a big challenge to flight crews and battalion staffs of aircraft conducting air movement operations. Aircraft on these missions will be under the control of the supported unit, normally in a DS role. However, the parent unit will still maintain C² functions for certain areas, such as maintenance, fuel, and CSAR. Since these aircraft will often be operating out of direct FM range from the parent headquarters, alternate arrangements must be made to keep the utility battalion aware of mission status. The commander may decide to deploy a retransmission team to bridge the gap and maintain FM communication with unit aircraft. Aircrews may be briefed to conduct periodic situation reports when in FM communications range or to arrange to provide SITREPs via MSE. Whatever technique is employed, it is essential that the utility unit recognize the communications challenge and determine a solution to overcome it.

g. *Flight Crew Mission Briefs.* Flight crews should be thoroughly briefed by the utility battalion staff prior to executing any air movement mission. For small scale air movement missions, a detailed OPORD or AB may not be necessary, but no flight crew should depart the AA without understanding their mission. Appendix H contains a suggested format for a flight crew mission brief that can be used to brief flight crews given a mission to conduct a small scale air movement operation.



CHAPTER 5

COMMAND AND CONTROL OPERATIONS

5-1. GENERAL

UH-60 aircraft can be configured with a C² console to provide maneuver commanders with an aerial C² platform. CACs have aircraft equipped with a command console that will allow commanders to move rapidly around the battlefield while maintaining communications with their subordinate units. C² aircraft allow commanders to maintain communications with their forces and provide timely information to support critical decisions without sacrificing mobility and efficiency.

5-2. ROLES AND MISSIONS

UH-60 aircraft can be task organized to provide C² support to maneuver commanders. Aircraft will be placed under the OPCON of the maneuver commander. C² aircraft may fly missions in support of the division command group, ground brigade commanders, or attack helicopter battalion commanders. C² aircraft will not normally be task organized below brigade level, except to support an attack helicopter battalion commander. Using a C² aircraft, the commander enjoys maximum mobility without sacrificing access to information and without jeopardizing continuity of operations due to CP relocation.

5-3. COMMAND AND CONTROL CONFIGURATION

a. Description. The UH-60 C² aircraft contains a command console and a map board that can function as an airborne or ground CP, providing communications in both secure and nonsecure modes. The C² aircraft provides the using commander with--

- VHF/AM or FM secure communications.
- FM SINCGARS frequency hopping/secure communications.
- HF secure with Have Quick I and II communications.
- SATCOM.
- HF nonsecure communications.

The C² aircraft is configured with a C² console in the front of the aircraft. The C² console contains the radio sets, console controls, and six ICS boxes for internal aircraft communications and receiving/transmitting on the console radio systems. The back row of the UH-60 contains a map board with 4 additional ICS boxes, allowing 10 personnel to be hooked up to the console's radio systems. The C² console is NVG compatible, allowing the commander to conduct C² operations at night. The C² console runs off of aircraft power and internal aircraft antennas. Figure 5-1 shows the aircraft configuration with the C² console installed.

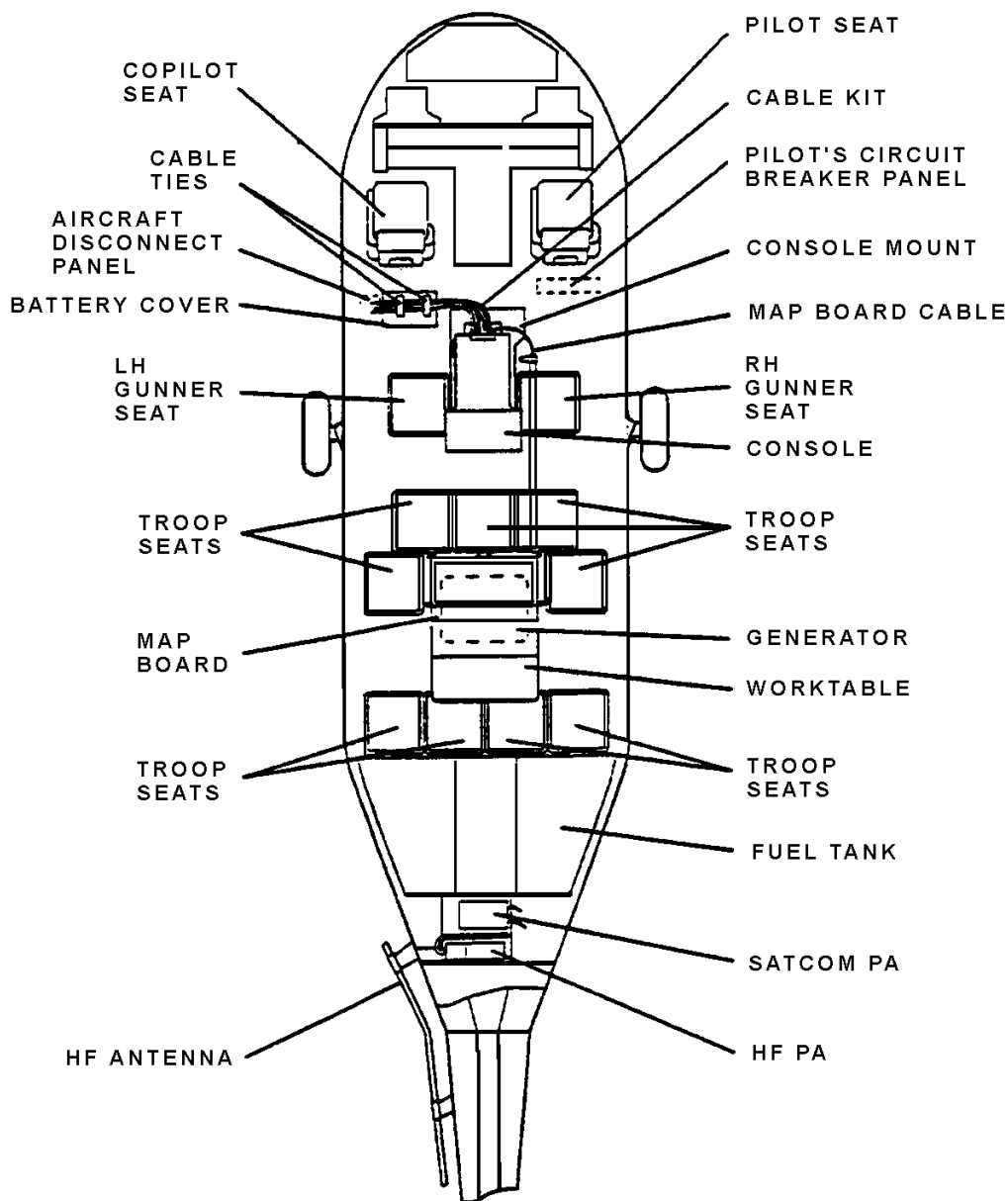

Legend: See the glossary for acronyms and abbreviations.

Figure 5-1. C² aircraft diagram

b. Ground Configuration. The C² console has the capability to operate in a ground mode. In this configuration the console can either remain mounted on the aircraft or can be dismounted and operated away from the aircraft. Using the C² console in a ground mode requires a generator for power and external antennas. Figure 5-2 shows the ground configuration for the C² console.

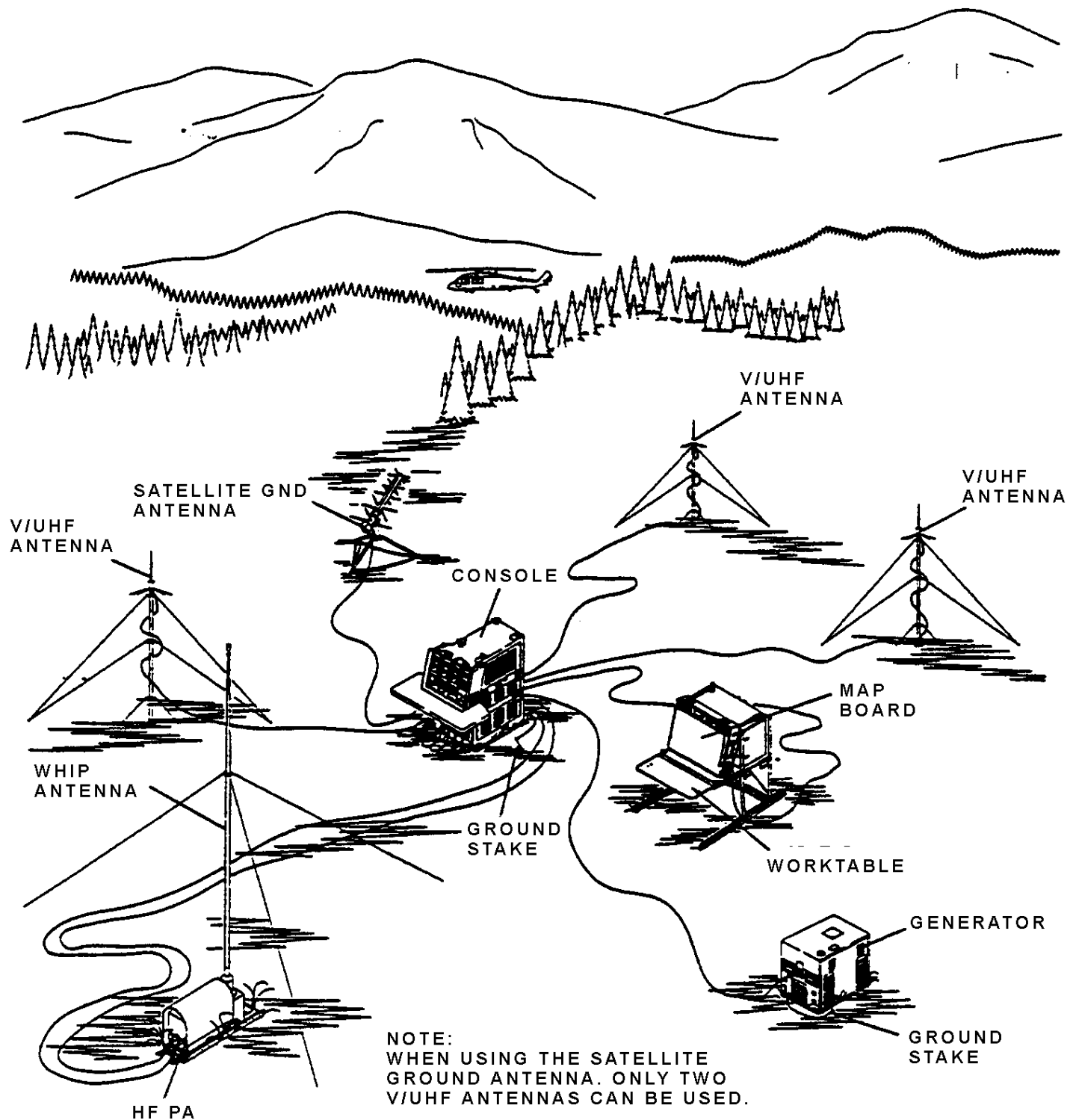

Legend: See the glossary for acronyms and abbreviations.

Figure 5-2. Ground based C² console

c. Capabilities.

- (1) With the ERFS mounted, the C² aircraft provides the commander with 4 to 6 hours of on-station time.
- (2) The C² aircraft console provides retransmission capability for VHF, UHF, and SINCGARS, increasing the communications range for the supported

unit.

- (3) C² aircraft console can be used for ground-based operations.
- (4) VHF/AM and UHF radio can store up to 30 preset frequencies.
- (5) C² aircraft console provides VHF and UHF scanning of up to four frequencies.
- (6) C² aircraft console can store two SATCOM preset channels.

d. *Limitations.*

- (1) An individual trained in the operation of the console is required to run the system. The crew chiefs of the aircraft are not C² system operators. The supported unit should have someone trained to operate the console.
- (2) It takes at least 1 hour and four personnel to remove the C² console from the aircraft for ground-based operations. Reinstallation in the aircraft requires special mounting hardware.
- (3) With only one SINCGARS radio, the console can only load six FM frequency hop sets at a time. This limits the commander's ability to communicate on all the FM channels that he needs, and retransmission capability is lost.

5-4. COMMAND AND CONTROL MISSION PLANNING CONSIDERATIONS

a. *Army Airspace Command and Control* . C² aircraft must operate within a designed airspace structure. Normally, a ROZ or ACA will be established for the C² aircraft. Selection of a suitable ROZ must consider several factors--scheme of maneuver, threat, communications, and routes to/from the ROZ.

- (1) ***Scheme of maneuver.*** The ROZ must be selected in an area that does not conflict with current operations of the supported unit. The S3, or S3 (air), of the supported unit should request the ROZ. The ROZ must be in an area that supports the maneuver commander's plan without interfering with the operations of subordinate units. It may be necessary to plan for multiple ROZs. In offensive operations, on order ROZs need to be planned so as the battle moves the C² aircraft can move forward and continue to provide effective C².
- (2) ***Threat.*** Aviation battalion S2s and S3s must carefully analyze the threat and the impact potential threats can have upon aircraft working in a ROZ. ROZ operations can be high risk. Often aircraft will be operating in a ROZ for an extended period of time and may go above the coordinating altitude. A careful analysis of the ROZ by the aviation unit will ensure that the ROZ can support the ground maneuver commander's concept and remain clear of high threat areas.

(3) Communications. The ROZ must be selected so that LOS communications are capable of being maintained with all elements of the unit. Altitude will be a factor in ROZ selection. Higher altitudes will allow for better communications, but will increase risk from threat systems. A careful analysis of the factors of METT-T will allow the ROZ to be selected in an area that provides security and uninterrupted communications.

(4) Routes to/from the ROZ. Flight routes must be developed that will support the aircraft's transition to the ROZ. These flight routes must be planned carefully, should avoid overflight of friendly artillery units and should be opened and closed as needed by the C² aircraft.

b. Console Operator. A console operator must be available to run the console operations while the commander and staff are controlling the battle. The operator may or may not be from the supporting aviation unit. There are no special requirements needed to operate the console, just an understanding of the system operational controls. The aviation unit may not have personnel available to operate the system. The supported unit commander must be prepared to provide an additional soldier to operate the console during missions.

c. Communications Fills. Some consoles require a fill from a modified ANCD, that exists at brigade level and higher. Coordination must be made as soon as possible after the receipt of the mission for the supported unit to provide the necessary ANCD fills. To ensure that the COMSEC fills are compatible, the console operator should conduct communications checks with the supported unit prior to mission execution. If unsuccessful, the aircrew should try loading the COMSEC fills from the secure loading device (KYK-13 or ANCD) at the supported unit.

d. Command Relationships. Aircraft conducting C² missions will be under the OPCON of the maneuver commander. The aviation unit providing the aircraft must coordinate with the supported unit early to integrate the C² aircraft during the planning process. The aircrew of the C² aircraft should attend orders and rehearsals of the supported unit to fully understand the operational scheme of maneuver and the concept for the C² aircraft.



CHAPTER 6

CASUALTY EVACUATION OPERATIONS

6-1. GENERAL

Commanders of medical units in a theater of operations use their resources to effectively evacuate and treat sick, injured, and wounded soldiers. Whether a soldier survives when wounded on the battlefield often depends on the time it takes to receive treatment. Quick responsive care is essential to protecting the force. Under current force structures, corps medical brigades are equipped with an evacuation battalion, each with 3 to 5 air ambulance companies with 15 UH-60s or UH-1s. Corps medical brigades may be augmented by attached air ambulance detachments and companies from the reserve component. The corps commander will task organize these air ambulances in direct support to division and ACR level on a priority basis. For planning purposes, division commanders can expect a company of MEDEVAC helicopters to be in direct support of the division. The air ambulance company will provide the division with responsive MEDEVAC support. However, during high tempo combat operations it may become necessary to reinforce the supporting MEDEVAC unit. If the situation requires movement of a large number of casualties, or if the force commander believes that reinforcing existing MEDEVAC assets is necessary, he may elect to use utility and cargo helicopters to move casualties to a treatment center. This chapter discusses the use of utility and cargo helicopters for CASEVAC.

a. *Medical Evacuation.* MEDEVAC is defined in [FM 8-10-6](#) as the timely, efficient movement and en route care by medical personnel of the wounded, injured, and ill persons, from the battlefield and other locations to MTFs. The term MEDEVAC refers to both ground and air assets. Divisions are equipped with both ground and air MEDEVAC assets.

b. *Casualty Evacuation.* CASEVAC is defined as movement of casualties to initial treatment facilities and movement of casualties to MTFs in the combat zone. It does not include en route care by medical personnel and implies that nonmedical assets (UH-60s or CH-47s) are being used to move casualties. CASEVAC should only be used when the unit has a large number of casualties (exceeding the ability of the MEDEVAC aircraft to carry) or MEDEVAC is not available.

c. *Casualty Evacuation Support for Operations.* Use of CASEVAC aircraft for combat operations will be determined by the force commander. He should always request the use of MEDEVAC aircraft first. If current MEDEVAC support is insufficient to meet his requirements for evacuation of casualties, he should request CASEVAC support from the aviation brigade. If necessary, requests to use utility helicopters for CASEVAC operations will be made through the division G3. MEDEVAC aircraft that are DS to a division will receive their missions through the DMOC. The DMOC is responsible for airspace control measures and mission planning for MEDEVAC assets. Utility and cargo aircraft conducting CASEVAC support will not be controlled by the DMOC; however, coordination should be made between the aviation brigade and the DMOC for deconfliction of aircraft evacuating casualties. Normally, utility and cargo helicopters will be task organized in a DS role no lower than brigade level. If task organized at division level, these assets will be under the

control of the main support clearing company, which locates in the division support area. If under the control of a brigade, the aircraft may be under the control of either the FSMC or the FSB SPO. In either case, the ground commander requesting CASEVAC support must understand that CASEVAC support provides transportation for casualties and does not provide any care en route to the treatment facility.

d. Advantages of Using Utility and Cargo Aircraft in the Casualty Evacuation Role.

- (1) The aircraft's speed and range make it possible to move casualties by air relatively long distances in a short period of time.
- (2) Helicopters can move patients quickly over rough terrain and get into areas inaccessible to ground ambulances.
- (3) Because of the range and speed, casualties can be transported to the MTF that can best deal with the patient's condition.
- (4) Utility and cargo aircraft can be diverted from other missions, making them available immediately.

e. Disadvantages of Using Utility and Cargo Aircraft in the Casualty Evacuation Role.

- (1) There is no en route medical care for casualties.
- (2) Aircraft in the CASEVAC role are not protected under the Geneva Convention.

6-2. LEVELS OF CARE

There are four levels of treatment that have a direct impact on patients as they are treated and evacuated from the FLOT to higher level care facilities. Utility helicopter assets can expect to transport patients between levels I and II. Levels III and IV transport will most likely be accomplished by the corps air ambulance company.

a. Level I. Care is provided by designated individuals or elements organic to combat and CS units. Emphasis is placed on those measures necessary to stabilize the patient and evacuate to the next level of care. Level I care includes individual care (self-aid, buddy aid, combat lifesaver) and battalion aid station care.

b. Level II. Care is rendered at a medical clearing station. Here the casualty is examined and wounds and status are evaluated to determine the treatment and evacuation precedence. Level II care includes the brigade medical clearing company, the division medical company, and corps medical assets.

c. Level III. Care is rendered at a medical treatment facility staffed and equipped to provide resuscitation, initial wound surgery, and post operative treatment. Level III care includes corps CSH, contingency hospitals, fleet hospitals, and hospital ships.

d. Level IV. In level IV care the patient is treated in a hospital staffed and equipped for general and specialized medical procedures.

6-3. BATTLEFIELD CASUALTY EVACUATION STRUCTURE

Evacuation of casualties on the battlefield begins with the individual unit. The tiered MEDEVAC

system begins at company level. Each successive level provides more life sustaining care. Utility helicopters will interact with this system to ensure that casualties are moved from the fight to medical aid as quickly as possible. Figure 6-1 shows the division medical structure.

a. Company Level Care. Company first sergeants and Xos are normally given responsibility to coordinate CASEVAC for the company. The first sergeant ensures that combat lifesavers have the required equipment on hand, and that company transportation, if available, is prepared to move casualties.

b. Battalion Level Care. Each maneuver battalion contains a medical platoon. If the situation dictates, the battalion aid station may split into two treatment teams. One team is headed by the battalion surgeon and the other by the battalion physician's assistant. These two teams, called the MAS and FAS can operate independently for up to 24 hours. The medical platoon has an ambulance section that has the responsibility of going forward to the maneuver companies and picking up casualties. They transport these casualties from the company collection point to the battalion MAS or the battalion FAS. Battalions may be augmented with a team from the ambulance section of the brigade FSMC.

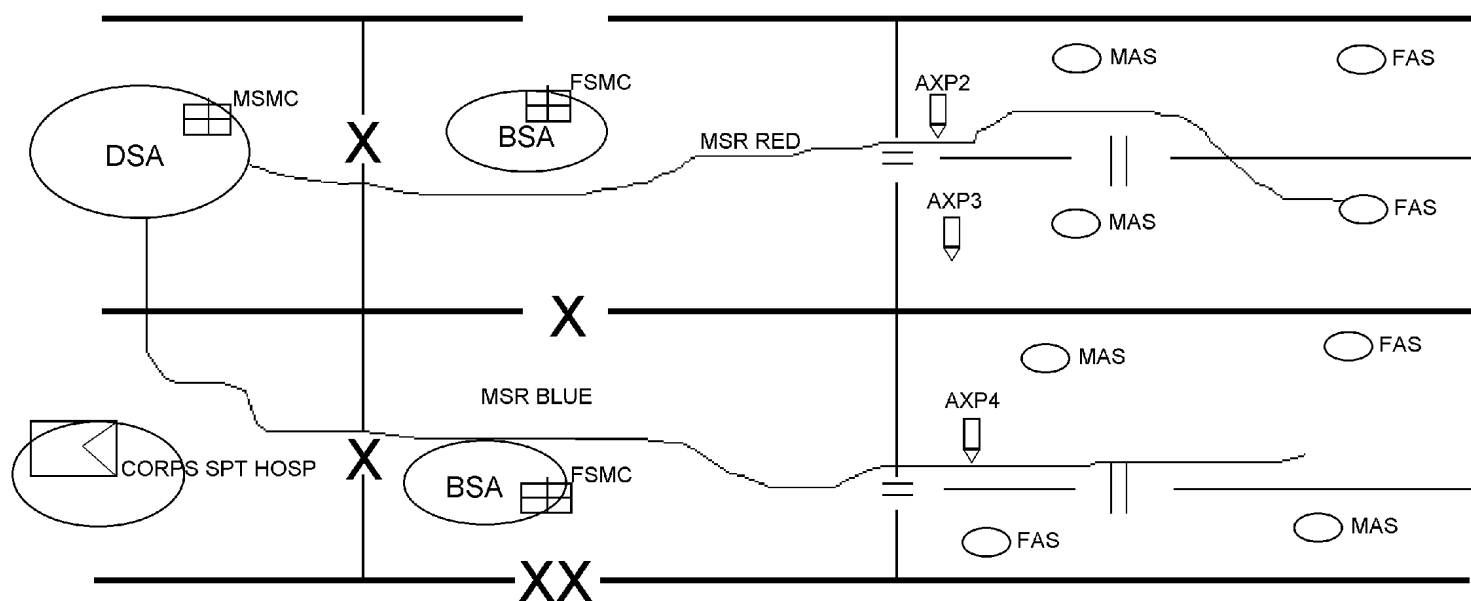

Legend: See the glossary for acronyms and abbreviations.

Figure 6-1. Division medical structure

(1) The MAS consists of the battalion surgeon, medics, and ambulances. At this location patients are evaluated, treated for immediate life sustaining care, and stabilized for transport to a higher level treatment facility. Equipment assigned to the MAS will vary depending on the type of battalion.

(2) The FAS is set up identical to the MAS, except that the primary care provider at the FAS is the battalion PA. It is equipped just as the MAS is and provides the same function.

(3) The MAS and FAS provide the battalion with two Level I medical care facilities. They normally operate in a "leapfrogging" mode. As the battle moves, the MAS and FAS will move to remain in support of the battalion. As one facility sets, the other will move forward of it (leapfrogging). This allows the maneuver battalion to sustain the tempo of the attack without loss of medical care. Additionally, if the battalion loses one aid station they continue to have a medical treatment facility.

c. *Brigade Level Care.* Casualties are moved from the battalion MAS and FAS to the FSMC located at the BSA. Battalion assets are responsible for transferring patients from the battalion aid stations to AXPs, where responsibility is passed to the brigade medical assets.

(1) *Ambulance exchange point.* An AXP is a location where casualties are transferred from the battalion to the brigade ambulances. AXPs will be designated in the OPORD under the service support annex. AXPs will be activated and deactivated based on the current situation on the battlefield. The brigade medical company will position ambulances from the ambulance platoon at the AXPs to accept casualties from the battalion. Evacuation will then be to the BSA.

(2) *Brigade forward support medical company.* The FSMC is located in the BSA. It is a level II treatment facility. The FSMC will establish an LZ within the BSA specifically for casualty movement operations.

d. *Division Level Care.* The division medical care consists of the MSMC. This level II facility is located in the DSA. Like the medical company in the BSA, this company will establish a casualty LZ located in the vicinity of the medical hospital.

6-4. UTILITY AND CARGO HELICOPTER CASUALTY EVACUATION CAPABILITIES

a. *UH-60s.* UH-60s can provide CASEVAC support to the brigade and division. The number of casualties that can be transported by the UH-60 varies depending on aircraft configuration, such as seats in or seats out and other equipment that may be on board the aircraft. Additionally, the severity of the wounds of the casualties, as determined by the company combat lifesavers or battalion medics, may determine the ACL for the UH-60 for particular missions. UH-60s can expect to be used as far forward as possible to evacuate casualties to the battalion aid stations (MAS/FAS) or the FSB medical company.

b. *CH-47s.* CH-47s can be used for CASEVAC using several different configurations.

(1) *Seats folded.* With seats folded up, the number of casualties that can be transported is dependent on the type of casualty (ambulatory versus litter) and the severity of the injuries and wounds to the casualties.

(2) *Seats down.* With seats folded down, the lifting capacity for litter patients will be reduced. Ambulatory capabilities in this configuration will be 30 seated ambulatory casualties and others loaded on the floor, as directed by the aircrew.

(3) *Litter configuration.* CH-47s can be equipped with a litter kit. This kit gives the CH-47 the capacity to transport 24 litter patients. When set up in the litter configuration, the CH-47 seats are replaced with six tiers of litters, four litters high.

Note: The litter support kit of the CH-47 consists of the poles and supports only. Litters and tie-down straps must be provided by the supported unit. The litters must be provided by the medical assets belonging to the unit the CASEVAC aircraft are supporting.

6-5. BACKHAUL OF CASUALTIES DURING AIR ASSAULT OPERATIONS

a. *General.* During air assault operations, the AATF staff and aviation battalion plan for the use of lifting aircraft to backhaul casualties from the LZ. Additionally, the force commander plans for MEDEVAC aircraft to support his operations. However, flowing MEDEVAC aircraft in during the air assault may become difficult and conflict with the ongoing operation. In this case, the AATFC and AMC will plan for CASEVAC operations by the assaulting aircraft. On air assaults with multiple lifts, the AATF plans for using the lifting aircraft to pick up casualties during successive lifts. On single lift air assaults, aircraft are designated to

remain on standby for CASEVAC operations. These aircraft will normally stand by at a central location, most likely the PZ, FARP, or established holding area.

b. Mission Planning. The backhaul of casualties on an air assault is a critical mission for the utility helicopters, and one that requires detailed planning to execute successfully. During the planning stages of the air assault, the AATF S3, S3 (air), AMC, aviation S3, and LNO must all be involved in the planning for this operation. If the AATF commander's intent is to backhaul casualties, then the planning must include the following considerations:

(1) Air assault task force commander's intent. The AATFC must clearly state his intent for casualty backhaul during the air assault. The AMC must inform the commander of the tradeoff between using lifting aircraft for backhaul and continuing with the air assault. If the AATF takes casualties early in an air assault operation, it may become necessary to reduce the amount of lifting aircraft to accomplish backhaul of casualties. The AATFC should determine the number of aircraft he can bump from the air assault to pick up casualties. He may decide not to bump any and conduct all MEDEVAC or CASEVAC after the completion of the air assault, or he may designate aircraft in each lift (such as the last two aircraft) for backhaul of casualties from the LZ. It is imperative that the AMC understand the AATFC's intent on casualty backhaul and advise him on courses of action.

(2) Casualty locations. The AATF should designate an area in the LZ for casualties to be brought. This will facilitate rapid movement and minimize ground time in the LZ for the aircraft. Since most air assaults will occur at night, it is critical that the casualty point be designated and that all members of the AATF know its location. The aircrews, as they arrive at the LZ, will be able to focus on the casualty point and be prepared to accept casualties.

(3) Signaling. Night operations provide a significant challenge for casualty backhaul operations. Light signals should be planned so that aircraft arriving at the LZ can be prepared to accept casualties. For example, a flashlight or chem light coming from the designated LZ casualty location may indicate that there are casualties to be backhauled. This way the aircrews know that they must remain on the LZ and be prepared to accept casualties.

(4) Communications. Once established in the LZ, communications on the CAN or a predesignated radio net can alert the flight of the necessity to backhaul casualties from the LZ.

(5) Designated area for dropping off casualties. The AATF commander must decide where to transport casualties if they occur during the air assault. During the planning process, the AATFC should develop a plan for the use of MEDEVAC helicopters. As the lifting aircraft drop off casualties, they can be loaded on to a MEDEVAC aircraft for transportation to higher level care facilities. Options include the PZ, the FSMC at the BSA, or another designated area. Considerations for selecting a casualty collection point should be--

(a) Casualty status. A site should be selected that is secure and has medical personnel ready to accept casualties.

(b) Aircraft availability. Aircraft conducting casualty backhaul will separate from the serial at some point. The AATF commander must be prepared to effect the bump plan if the aircraft carrying casualties do not return to the PZ for the next lift.

(c) Confusion. A casualty collection point should be selected so that it does not interfere with the air assault that is still in progress. Aircraft arriving at the

PZ full of casualties may cause confusion on the PZ as troops are trying to load, and casualties are being unloaded from the aircraft.

(d) Aircraft rejoin. A site should be selected that allows the lifting helicopters to quickly drop off the casualty and return to the PZ to continue the tempo of the air assault operation.

6-6. CASUALTY EVACUATION MISSION PLANNING CONSIDERATIONS

CASEVAC mission planning must be detailed. The air movement planning considerations listed in Chapter 4 apply to CASEVAC operations as well. Units conducting CASEVAC missions should refer to this chapter to thoroughly plan and accomplish the mission. In addition, the following mission planning considerations should also be considered when preparing to conduct a CASEVAC mission:

a. Landing Zones/Pickup Zones. LZs /PZs for CASEVAC operations are the responsibility of the supported unit. For example, battalion aid stations are responsible for setting up the LZ/PZ for CASEVAC operations. LZ/PZ selection criteria for a CASEVAC LZ/PZ are location, marking, communications, capacity, and obstacles.

(1) Location. The LZ/PZ must be in close proximity to the aid station. Casualties may have to be carried by hand to the waiting aircraft. However, the LZ/PZ must be set up at a distance where it will not interfere with aid station operations. If possible, set the LZ/PZ up downwind from the aid station. This will help prevent blowing dust on the aid station. A minimum distance of 150 meters should be acceptable to keep aircraft from interfering with aid station operations.

(2) Marking. LZ/PZ markings must be visible from the air. During the day, marking of the LZ/PZ can be accomplished using a VS-17 panel, smoke, or signal mirror. If using a VS-17 panel, ensure it is visible from the air. At night, an inverted Y is used to designate the aircraft touchdown point. However, this may not be visible from the air. LZs/PZs should also have a far recognition signal, such as a swinging chem light or strobe light, to make the LZ/PZ easier to find.

(3) Communications. Air-to-ground communications should be maintained between the aircraft and the LZ/PZ. Effective communications will make movement times faster and assist the aircraft in locating the LZ/PZ.

(4) Capacity. LZ/PZ selection is based on the number of aircraft and type aircraft that will be used for the CASEVAC operation. The size determines how many aircraft can be landed at one time to load casualties.

(5) Obstacles. LZs/PZs should be free of obstacles. Obstacles such as cables, wires, antennas, large rocks, excessive slope, and large ruts can make the location unsuitable. Obstacles that cannot be cleared from the location should be marked. If communications are maintained with the aircrew, advisories should be provided to the crews as to hazards in the LZ/PZ.

b. Medical Support. As defined, CASEVAC operations do not provide any en route medical treatment. Commanders and medical personnel must consider this when determining if utility helicopters should be used to transport casualties.

c. Litters. Flight crews conducting CASEVAC missions must be told what to do with litters. The battalion aid stations need to have litters resupplied as casualties are evacuated to a higher level of care. Aircraft on CASEVAC missions may need to pick up litters at the drop off location and return them to the casualty PZ to keep the battalions resupplied. For example, once helicopters move casualties from a battalion aid station (MAS or FAS) to the

BSA, the MAS or FAS may need the aircraft to backhaul litters for use in further CASEVAC missions. Flight crews must be briefed of this requirement and be prepared to execute litter backhaul to keep the battalion aid stations supplied with necessary litters.

d. Army Airspace Command and Control. If the division has MEDEVAC aircraft attached or OPCON to it, the DMOC will be responsible for planning the A²C² measures that these aircraft will be using. Utility helicopters conducting CASEVAC missions in support of the medical companies of the BSA or DSA should check with the DMOC for the current MEDEVAC airspace structure. These procedures will also be specified in the airspace control order or SPINS.



CHAPTER 7

COMBAT SEARCH AND RESCUE

Recent combat experience has demonstrated the importance of commanders at all levels to plan for CSAR. In Vietnam, the ratio of rescued pilots to those taken as POW was 2.1:1. During Desert Storm, the ratio dropped dramatically, to 1:5.75. For every one downed pilot rescued, almost six were taken prisoner. Further, 72 percent of all rescued pilots in Vietnam were rescued in the first 2 hours following their downing. In Desert Storm, none of the rescued pilots were picked up in the first 2 hours. Commanders at all levels must have a plan for picking up downed pilots. Utility helicopters will play essential roles in CSAR. Although the Army has no aircraft dedicated solely to performing CSAR, all utility helicopters must be prepared to accomplish this mission. This chapter discusses roles for CSAR, CSAR imperatives and planning factors, SAR procedures, and individual aircrew responsibilities for CSAR. Detailed procedures for joint CSAR can be found in Joint Publication 3-50.2. Army CSAR procedures can be found in [FM 90-18](#).

7-1. COMBAT SEARCH AND RESCUE FUNCTIONS

Each service is responsible for performing CSAR in support of their own operations.

a. *Joint Force Commanders.* JFCs have primary responsibility for CSAR in their AOR. JFCs will normally delegate the responsibility for picking up downed aviators to the force component commanders. Additionally, the JFC should establish a JSRC.

b. *Joint Search and Rescue Center.* The JSRC is a primary SAR facility equipped and staffed to plan, coordinate, and execute joint CSAR operations. This facility is operated by personnel from two or more services. JSRC responsibilities include--

- (1) Developing and disseminating SPINS to be included in the air tasking order. SPINS specify the primary theater CSAR guidance, concepts, and specific instructions.
- (2) Alerting components of known locations of isolated personnel.
- (3) Coordinating with national, theater, and host nation intelligence assets for information regarding the area around the isolated personnel.

(4) Coordinating and deconflicting CSAR operations among the different services.

(5) Monitoring all CSARs performed by the RCC.

c. Component Commanders. The Army component commander, as part of a joint force, is responsible for planning and coordinating CSAR in support of Army operations. To do this, the Army component commander establishes a RCC.

d. Rescue Coordination Center. An RCC is established by the Army component commander to plan, coordinate, and execute CSAR operations within the commander's AOs. The component commander may not directly establish an RCC. If an RCC is not established, the Army commander must designate an existing headquarters or staff section to perform the duties of the RCC. The RCC is responsible for--

(1) Notifying the JSRC as soon as possible when conducting CSAR operations.

(2) Extracting information from the JSRC E&R plan that is Army specific and disseminate that information to all Army units in theater.

(3) Requesting JCSAR support from the JSRC when the CSAR can not be accomplished by Army assets.

(4) Forwarding pertinent data regarding isolated personnel to the JSRC.

e. Unit Commanders. Unit commanders must be prepared to conduct CSAR operations in support of their own operations. Commanders must ensure that CSAR contingencies and CSAR procedures are incorporated into their plans and orders.

7-2. COMBAT SEARCH AND RESCUE IMPERATIVES

a. Immediate Recovery. History has demonstrated that the quicker a downed aviator is located and rescued, the greater his chances of survival. Army aviation commanders must plan to use their assets to conduct CSAR. CSAR must be integrated into all operations.

b. Detailed Planning. CSAR operations must be planned in detail. This is essential for operations that are cross-FLOT. Commander's must integrate utility helicopters into their operational plans for use as CSAR platforms and ensure all aircrews understand the immediate CSAR procedures established for a particular mission.

c. Decision Process. Commander's must make a critical decision if aviators are lost during a mission. This decision must be made rapidly, but with caution. Commanders must not risk losing more aircraft by committing assets into an area that is high threat. A commander must consider the factors of METT-T when deciding to execute an immediate recovery, delayed recovery with his own

assets, or delayed recovery using joint CSAR assets. Figure 7-1 shows a commander's CSAR decision making cycle.

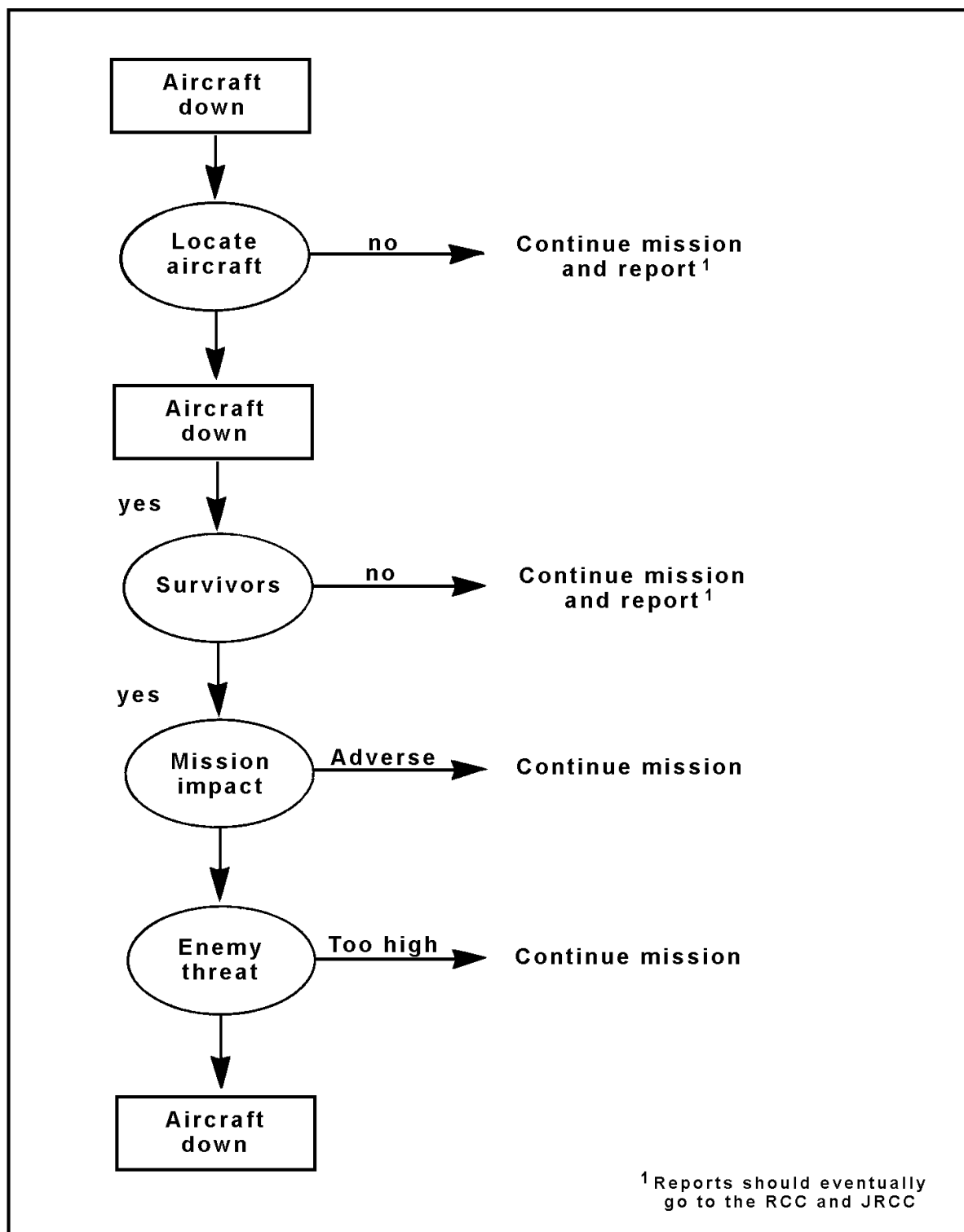

Legend: See the glossary for acronyms and abbreviations.

Figure 7-1. CSAR decision matrix

d. Use of Available Resources. Commanders must dedicate all available resources to recovery of downed aviators. If the commander decides to attempt an immediate CSAR, consideration must be given to availability of air cavalry and attack helicopters to escort the rescuing aircraft, fire support, and EW assets that are available to support the operation.

7-3. COMBAT SEARCH AND RESCUE OPERATIONS

CSAR operations can be placed into two separate categories--immediate and deliberate.

Commanders must recognize and prepare for both types of CSAR operations.

a. *Immediate Recovery.* Immediate recovery is the rescue of downed aircrews during the conduct of a mission. For example, during an air assault, immediate recovery would be accomplished by having an aircraft in the flight follow a downed aircraft to rescue the flight crew. Immediate recovery is the most effective method for rescuing downed aircrews. Immediate pickup of downed aircrews is desirable because friendly aircraft are in the area, enemy forces have not had the opportunity to react, and medical treatment, if required, will be most beneficial. The commander must consider certain factors when planning for immediate recovery.

(1) *Continuation of the mission.* Immediate recovery may take aircraft away from the primary mission. Commander's must consider the intent of the mission and decide if it is feasible to take an aircraft away from an ongoing mission to conduct an immediate recovery mission. If the mission is an air assault, the aviation commander must consult with the AATFC before executing immediate recovery. The aviation commander may decide to have a flying spare aircraft designated to conduct immediate recovery if required.

(2) *Pick up aircraft.* The commander may designate specific aircraft with the responsibility to conduct immediate recovery, or the responsibility may fall on the nearest aircraft in support of the downed aircraft. The commander must specify and select the aircraft to be used for immediate recovery during the planning process.

(3) *Recovery aircraft location.* The aircraft designated for immediate recovery may be a part of the mission and formation, or it may be an additional aircraft. The commander must decide where to position the CSAR aircraft so that it can best support the pickup of downed aircrews and not interfere with the ongoing mission.

(4) *Army airspace command and control.* Separate airspace control measures may be developed to allow CSAR aircraft to extract downed aircrews without interfering with the ongoing mission. If the CSAR aircraft will use the same structure as the mission aircraft, effective C² must be established to deconflict aircraft.

b. *Delayed Recovery.* Delayed recovery is planned as part of the commander's operations. Using the RCC and JSRC assets for CSAR are part of a delayed recovery operation. However, commander's may use internal assets to conduct a delayed recovery. A delayed recovery will normally occur after the completion of the current mission and includes a detailed plan for conducting rescue of downed aviators. Aircraft designated as CSAR aircraft must be integrated thoroughly into the plan. Planning considerations for aircrews conducting a delayed recovery

CSAR mission are as follows:

(1) Concept of the operation. Aircrews designated to provide CSAR coverage must understand the operations that they are supporting. If utility helicopters are not supporting their parent headquarters, they should be placed under the OPCON of the operational commander. The aircrews must be integrated into the planning process and attend all plans, orders, and rehearsals. The commander must establish a CSAR concept to support his operations. CSAR concepts may include:

- Moving CSAR aircraft as part of the operation, following maneuver elements and maintaining a standoff distance to provide CSAR coverage if necessary.
- Moving the CSAR aircraft forward to a holding area and awaiting a call to conduct CSAR, if necessary. Using this method, the commander may elect to establish a ROZ for the CSAR aircraft so that the aircraft can stay airborne.
- Keeping the CSAR aircraft at another location (AA, FARP) and assuming appropriate REDCON level as determined by the commander.

The commander must consider the factors of METT-T, the complexity of the scheme of maneuver, and the threat potential when considering how to use and plan for internal CSAR.

(2) Communications procedures. Aircraft that are shot down on the battlefield may or may not be able to use the radios onboard the aircraft to communicate. The commander must consider how communications with downed aircrews will be established. Communications may not be necessary for immediate CSAR.

(3) Command and control. C² of the CSAR must be planned in advance. A C² node must be designated and an AMC must be designated for the CSAR operation. Procedures need to be devised to form the CSAR force, move the force forward, and conduct the rescue of the downed aircrew. During the mission, the C² node is responsible for coordinating fires, deconflicting security and the rescue aircraft, and controlling the rescue of the aircrew.

(4) Signaling. Signaling procedures must be developed. It may become necessary for the downed crew to evade and leave the aircraft site. Signal procedures must be coordinated during the planning process to allow for quick pickup of downed aviators.

(5) Drop off location. CSAR crews must be thoroughly briefed on the location to drop off downed pilots once they are rescued. If they are not injured, they may be returned to the aviation unit AA. If injured, the crew must be taken to a medical facility. The CSAR crews should have frequencies and call signs of medical treatment facilities and have their locations programmed into their navigation devices (GPS, Doppler, etc).

(6) Combat search and rescue team makeup. The commander must determine the makeup of the team that will be conducting the delayed recovery. This operation should consist of attack or cavalry assets to

provide reconnaissance and security, a C² facility, and at least two aircraft for the rescue operation. Using two aircraft allows for faster search times, a backup aircraft should the primary break down, and the ability to move more dismounted personnel for security. Additionally, the commander should designate medical personnel to accompany the recovery aircraft to provide initial medical aid when the downed crew members are recovered.

7-4. COMBAT SEARCH AND RESCUE MISSION EXECUTION

Utility helicopters used for CSAR operations should only be used to conduct the rescue of downed aviators. Commanders should try to conduct the search for downed aircrews with cavalry or attack helicopter assets. It may be that Army utility or cargo helicopters will work with USAF aircraft to conduct a JCSAR mission. In this case the helicopters would be moved forward to a holding area and be directed to the pickup site by the USAF aircraft conducting the search. If the isolated personnel are not located, the helicopters will not be involved in the mission. This may not always be possible, and utility and cargo helicopter crews should be prepared to conduct a full CSAR mission if called upon. Considerations for the execution of the CSAR mission are listed below:

a. Intelligence Updates. The aircraft conducting the mission should use all available intelligence sources to find out about the threat in the search area. The S2 of the aviation battalion can use other available sources to give the aircraft the most current threat situation.

b. Information on the Downed Crew. Utility and cargo aircraft conducting CSAR missions should have access to--

- ISOPREP packets. These cards contain personal information about the crew to include a picture. They are used to make a positive identification when picking up an individual.
- EPA. This is the plan the downed personnel will execute if immediate rescue is not available or feasible. It discusses the nearest DARPs the crew will move to for pick up, signaling methods, authentication they will use, and frequencies they will have loaded into their survival radio.
- Signaling procedures.

c. Search Techniques. It may be necessary to conduct a search for downed aircrews. If this becomes necessary, search aircraft should use the following search techniques:

(1) Boundary method. CSAR forces conduct the operation by designating the entire search area within the confines of prominent terrain features. The next step is to further reduce the search area into subelements also defined by identifiable terrain features. From the larger to the smaller scales, terrain features such as mountains, rivers, small towns/villages, secondary roads, and natural or man-made obstacles can be used to piecemeal the operation. The search track will be conducted systematically within the shape of the terrain parameters until the isolated personnel have been acquired.

(2) Grid method. CSAR forces conduct the operation by designating boundaries and search patterns using eight-digit grid coordinates to define the search area.

(3) Track line method. CSAR forces conduct this operation by planning search routes along what is estimated to be the isolated personnel's track from isolation point to the extraction point, according to the EPA. These search areas will consist of a series of connected rectangular boxes, defined in terms of length and width, initiating at the isolation point and continuing to the planned extraction point.

(4) Feature trace. CSAR forces conduct this operation by searching along specific terrain features estimated to be used by the isolated personnel, according to their EPA. These features may include rivers, roads, etc. Threat lines of communication and other high traffic areas should be avoided.

(5) Reference trace conducted over large bodies of water without reference to land. This method will usually be done in conjunction with a rescue ship. The ship establishes a track and the aircraft flies a pattern that crosses the bow of the ship in an "S" shaped pattern in front of the ship.

d. Code Words/Authentication. Once the isolated personnel are located, the rescue aircraft must be prepared to authenticate and set up the rescue operation. Once contact is made with the isolated personnel, the flight crew must proceed cautiously. Downed aircrews will be very excited about the prospect of rescue. It is critical that the contacting CSAR aircraft attempt to keep the isolated personnel calm. Locations should be given in code, or with reference to terrain features, or designated SAFE points, if possible. Threat EW assets may be monitoring, and giving the location of isolated personnel on an unsecured radio net will alert the enemy to the location as well.

7-5. INDIVIDUAL COMBAT SEARCH AND RESCUE PREPARATION

CSAR planning should begin when the army force deploys or immediately after arrival in the AOs. Commanders of aviation units must place emphasis on the CSAR process and ensure that their units are prepared in the event an aircraft is lost during the fight. Procedures that should be followed to ensure aircraft are prepared for CSAR are--

a. Single Aircraft Operations. Commanders must consider if single aircraft operations are desirable. Aircraft operating together increase the possibility for immediate CSAR. The factors of METT-T must be weighed for missions being flown to allow the commander to make the best decision in this area.

b. Evasion Plan of Action. Each aircrew must have an EPA for missions being flown. It may not be possible for communications to be established once an aircraft goes down. The aircrew must be prepared to conduct evasion in case communications are not possible or the enemy situation dictates. A predetermined evasion plan will help make successful CSAR possible.

c. Isolation Preparation. Commanders need to ensure that all aircrews have

current ISOPREP cards filled out, and that they are accessible in case they are needed.

d. *Special Instructions/Air Control Order.* These documents provide a wealth of information, particularly with the current CSAR procedures. The SPINS and ACO will contain current authentication codes, CSAR special procedures (such as word of the day, color of the day), active SAFE points, and other information. Flight crews must be familiar with these procedures prior to executing missions.

e. *Survival Radios.* Aircrews must ensure that their survival radios are operational, have the appropriate frequencies programmed into them, and that they know how to use them.



CHAPTER 8

AERIAL MINE WARFARE (VOLCANO)

The primary mission of the Volcano mine dispensing system is to provide the force commander with the capability to rapidly emplace large minefields under varied conditions. The Volcano can be attached to the UH-60. It is used to emplace minefields designed to reinforce existing obstacles, close lanes, gaps, and defiles, and protect flanks.

8-1. THE VOLCANO MINE DISPENSING SYSTEM (DESCRIPTION)

The Volcano mine dispensing system consists of the M139 mine dispenser, the M87 mine canisters, DCU, carrying cases, and special mounting hardware. The system for the UH-60 is identical with the ground version of the volcano, except the mounting hardware. Figure 8-1 shows the M139 mine dispensing system mounted on a UH-60. Each system can dispense mines 35 to 70 meters from the aircraft flight path. The aircraft flies at a minimum altitude of 5 feet, at speeds ranging from 20 to 120 knots. One aircraft can deliver up to 960 mines per sortie. Each division, corps aviation brigade, and regimental aviation squadron is equipped with three air Volcano systems. The aviation unit that owns the systems is responsible for transporting and mounting the air volcano. Employment of the Volcano system will be planned at division level by the ADE, and ammunition for the system will be located at ATP or ASP.

a. M87 Mine Canister. The M87 mine canister is prepackaged with five AT mines and one AP mine. The mixture of mines is fixed and cannot be altered in the field. The group of mines in each canister are electrically connected by a nylon web that also functions as a lateral dispersion device as the mines exit the canister. Spring fingers mounted on each mine prevent the mine from coming to rest on edge. Upon coming to rest, each mine has a delayed arming time. The AT mine takes 2 minutes and 15 seconds to arm, and the AP mine takes 4 minutes to arm.

b. M139 Dispenser. The dispenser consists of four launching racks that are mounted in the doors of the UH-60. Each rack can hold up to 40 M87 mine canisters. Each canister contains six mines, so the total capacity for the M139 dispenser is 960 mines. The mounting hardware secures the racks to the UH-60 and provides for a jettison assembly that can propel the racks away from the aircraft in case of an aircraft emergency.

c. Dispensing Control Unit. The DCU is the central control panel for the air Volcano mine dispensing system. The operator uses the DCU to perform fault isolation tests on the system, to provide delivery speeds, set self-destruct times, and initiate the arming sequence of the system. The start-stop firing switch is located on both cyclic sticks, allowing either pilot to initiate or stop the dispensing of mines. A counter on the DCU indicates the number of canisters remaining on each side of the aircraft.

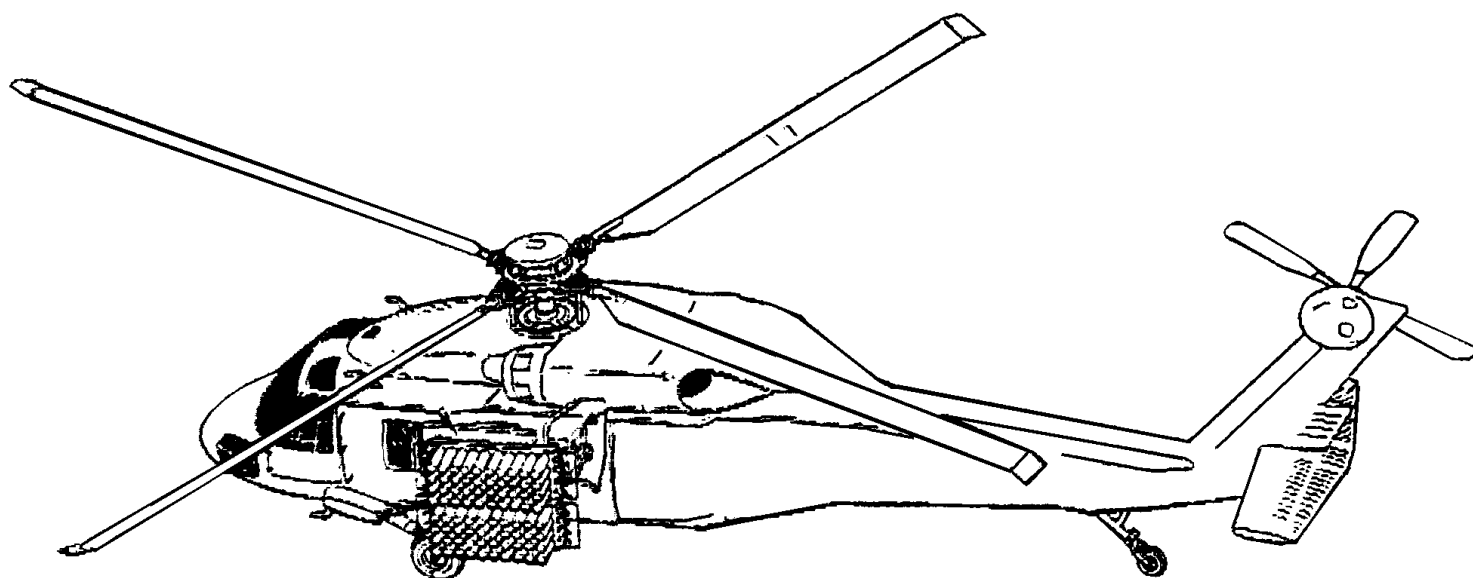

Figure 8-1. Air Volcano system

8-2. CAPABILITIES AND LIMITATIONS

a. Capabilities.

- (1) Each aircraft carries 960 mines (800 AT mines, 160 AP mines).
- (2) The mines have three programmable self-destruct times (4 hours, 48 hours, or 15 days).
- (3) The system allows the force commander to quickly lay minefields. The Air Volcano is capable of emplacing a planned (on order/be prepared) minefield 1,115 meters by 120 meters with 960 mines in as little as 17 seconds.
- (4) The system is designed to provide the commander with an offensive or defensive mine dispensing capability.
- (5) Air Volcano allows the commander to emplace a minefield at night.

b. Limitations.

- (1) The air Volcano system weighs 6,413 pounds. With air Volcano mounted, a full crew, and one system operator, the aircraft will be close to maximum gross weight. It may be necessary, based upon weather and environmental conditions, for the aircraft to execute the mission without a full fuel load, reducing en route time.
- (2) The flight crew cannot operate the M60D machine gun with the air Volcano installed.
- (3) It takes approximately 4 hours for the system to be installed in the UH-60.
- (4) The three systems assigned to a division require two 5-ton cargo trucks for transport. The aviation unit that owns the system does not get an increase in their assigned number of vehicles, so the transportation of the systems must come from internal battalion assets.

8-3. EMPLOYMENT PRINCIPLES

a. The Volcano system can emplace a minefield with an average AT mine density of 0.72 mines per meter and an AP density of 0.14 mines per meter. The densities will vary slightly since some mines will fail the arming sequence and self-destruct 2 minutes after dispensing, some mines may not orient correctly, or will not deliver their full mine effect. The probability of failing the arming sequence or misorienting is relatively small and does not appreciably degrade the minefield lethality. For tracked vehicles, the AT density yields more than 80 percent probability of encounter. Volcano AT mines do not have antidisturbance devices but are highly sensitive to movement once they are armed.

b. Air Volcano can be used to emplace four types of minefields--disrupt, fix, turn, and block. The force commander determines the type of minefield to be emplaced based upon the desired effect of the minefield. Table 8-1 shows the planning factors for the different types of minefields. Table 8-2 shows the time required to emplace minefields at different airspeeds. General guidelines for determining the type of minefield the commander will emplace are as follows:

(1) **Disrupt.** For this minefield, the lethality and density is low. The commander's intent is to cause confusion in the enemy formation.

Table 8-1. Volcano planning factors

TYPE OF MINEFIELD	DEPTH (METERS)	FRONT (METERS)	NUMBER OF STRIPS	CANISTERS PER STRIP	TOTAL CANISTERS	MINEFIELDS PER LOAD
DISRUPT	140	278	1	40/20 PER SIDE	40	4
FIX	140	278	1	40/20 PER SIDE	40	4
TURN	340	557	2	80/40 PER SIDE	160	1
BLOCK	340	557	2	80/40 PER SIDE	160	1

Table 8-2. Minefield emplacement times

KNOTS	disrupt and fix MINEFIELD	TURN AND BLOCK MINEFIELD	160 CANISTER LOAD

20	27 Seconds	54 Seconds	108 Seconds
30	18 Seconds	36 Seconds	72 Seconds
40	13 Seconds	27 Seconds	54 Seconds
55	<u>9 Seconds</u>	18 Seconds	39 Seconds
80	<u>6 Seconds</u>	<u>13 Seconds</u>	27 Seconds
120	<u>4 Seconds</u>	<u>9 Seconds</u>	18 Seconds
Width of Minefield	278.7 Meters	557.5 Meters	1,115 Meters
Number of Passes Per Minefield	Disrupt and Fix	2 (See Note)	1
Number of Canisters Per Pass	27 Seconds	80 Canisters	160 Canisters

Notes: Black Hawks operating in pairs can lay turn and block minefields in one pass, firing 80 canisters each. Underlined items indicate airspeeds that are not recommended for Volcano dispensing operations

(2) Fix. For this minefield, placement is critical. The commander plans this type of minefield carefully. The location must be synchronized to allow the ground forces to mass their fires on the enemy once the enemy has been fixed by the obstacle.

(3) Turn. For this minefield, density and lethality are critical. Individual minefields may be stacked so as to influence the enemy movement. The commander's intent is to influence the maneuver of the enemy formations.

(4) Block. For this mine field, the commander is attempting to deny the enemy use of terrain. This minefield requires high density and lethality, as well as reinforcement from other obstacles (natural and man-made), to help stop the enemy's use of the

terrain.

c. Disrupt and Fix Minefields. Disrupt and fix minefields use one centerline to give a minefield depth of 140 meters. The strip centerline is 278 meters long. The aircraft moves toward the start point, maintaining the ground speed selected in the DCU. The pilot initiates the launch by depressing the launch switch at the desired start point, and finishes the launch by again depressing the launch switch over the selected finish point. Figure 8-2 shows an example of a disrupt and fix minefield.

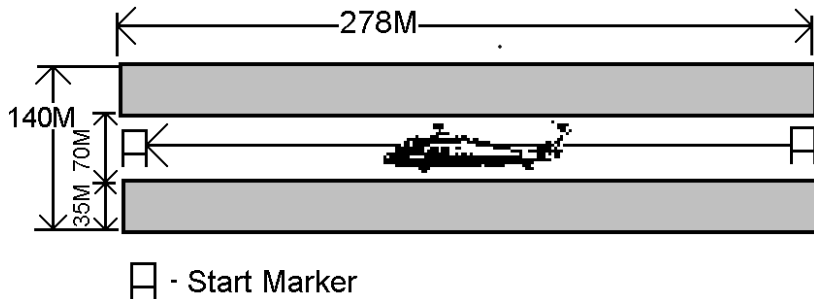

Legend: See the glossary for acronyms and abbreviations.

Figure 8-2. Disrupt and fix minefields

d. Turn and Block Minefields. Turn and block minefields are emplaced using the same basic procedures as disrupt and fix minefields. However, turn and block minefields use a two strip centerline to give a total minefield depth of 340 meters. The strip centerline is 557 meters long. The emplacement of turn and block minefields requires one aircraft to make two passes. If two aircraft are available, the time to emplace the minefield is cut in half. Additionally, it may be possible to use one ground and one air Volcano system to emplace these types of minefields, each system providing a different strip. Figure 8-3 shows an example of a turn and block minefield.

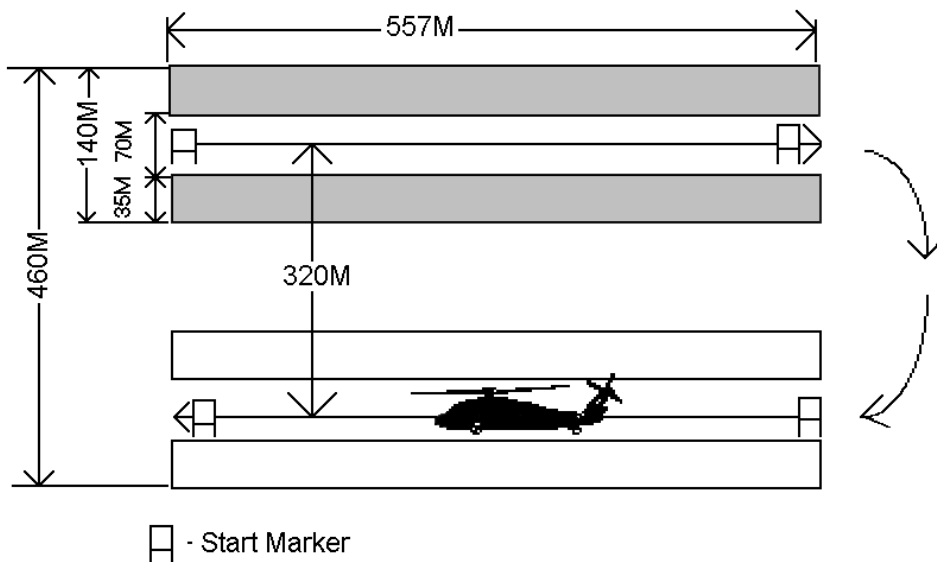

Legend: See the glossary for acronyms and abbreviations.

Figure 8-3. Turn and block minefields

8-4. AIR VOLCANO IN COMBAT OPERATIONS

a. Air Volcano in Offensive Operations. During offensive operations, Volcano mines can

be rapidly emplaced by air to secure a flank during a movement to contact. The Volcano mines can be used to block potential avenues of approach from a flank and reduce friendly forces vulnerability to enemy counterattack. During a deliberate or hasty attack, an exposed flank can be quickly reinforced by helicopter emplaced minefields. Additionally, routes out of the objective can be blocked to deny the enemy potential counterattack routes or avenues for withdrawal.

b. Air Volcano in Defensive Operations. During defensive operations, air Volcano mines can be quickly emplaced in the covering force area to delay and disrupt enemy formations. When used to reinforce natural obstacles, air emplaced minefields provide the covering forces with the time and opportunity to engage the attacking enemy forces. In the MBA, turning minefields can be emplaced to force the enemy into engagement areas and fixing minefields can be emplaced to support the destruction of the enemy.

c. Employment Guidelines. Air Volcano minefields may be emplaced in the deep battle or close battle areas. Commanders must develop a plan for minefield coverage. It may be necessary when emplacing deep minefields to emplace scouts or COLTs to maintain observation on the minefield. Utility helicopters can expect to emplace these scout teams along with the minefield.

d. Employment Principles.

(1) Deliberate and hasty dispensing. Based upon the enemy situation, the pilots must decide whether to conduct a deliberate or hasty dispensing run. A deliberate run means that the pilots will make a preliminary "dry" run to verify the positions of the start and end points, check the terrain, and verify altitude and airspeed for the actual dispensing run. In hasty situations the pilots will not be able to make a dry run. He must rely on detailed mission planning and a thorough map reconnaissance to emplace the minefield on the first run.

(2) Site layout. Site layout for air Volcano minefields is extremely important. When the situation allows, the limits of the minefield are marked before minefield emplacement. When the situation does not allow premarking of the site, the flight crew must determine through premission planning and reconnaissance (map and actual) the start and stop points and minefield limits.

e. Air Volcano Delivery Techniques. Positive control of air Volcano missions are essential. It is imperative that the flight crew emplace the mines at the right location. Failure to put the mines in the correct location will decrease the desired effect of the minefield and increase the potential for fratricide, especially for unobserved deep battle minefields or hasty minefields that may not be marked. The following techniques have been developed to ensure that the mines are emplaced in the correct location:

(1) Visual identification technique. This positive control technique focuses on visual identification for emplacement of the minefield. During the preparation stage, engineer units will mark the limits of the minefield and the start and stop firing points for the Volcano. This provides a visual signal for the pilot to start and stop the firing of the canisters. This control technique is good for open terrain with adequate visibility and little canopy coverage.

(2) Time lapse technique. This control technique focuses on airspeed versus Volcano firing times. Once the firing is initiated by the pilot at a predetermined start point, the canisters are fired for a preset time based upon the aircraft airspeed (see Table 8-2). This technique is good for limited visibility conditions or when time does not permit for complete marking of the minefield. The engineer unit (or another designated unit) will still be required to mark the minefield start point.

(3) *Canisters fired technique.* This positive control technique focuses on number of canisters fired. Once the air Volcano is initiated, the pilot terminates the firing when the DCU counts down to a predetermined number of canisters. Number of canisters fired is based upon the type of minefield that will be emplaced (see Figures 8-2 and 8-3). This technique is good for limited visibility situations, when the minefield area is covered, and when time to fully mark the minefield is limited. This technique allows the flight crew to focus on flying the aircraft, since the operator or crew chief can monitor the DCU and announce when the desired number of canisters has been dispensed. It will reduce pilot workload. This method, when combined with the time lapse technique, will provide for an accurately emplaced minefield.

(4) *Doppler/global positioning system guidance technique.* This technique focuses on using aircraft navigation systems to emplace the minefield. During the mission preparation phase, the planners conduct a thorough map reconnaissance. They determine the grid coordinates for the start and stop firing points. These grids are provided to the pilots, who place the points into their navigation systems. When the start point is reached, the pilot initiates the firing and terminates at the end point. This technique is good for minefields emplaced in the deep fight and for hastily emplaced minefields. Pilots using Doppler navigation systems must pay attention to the accuracy of the system and ensure that updates are accomplished accurately to ensure the minefield is emplaced in the desired location.

8-5. AIR VOLCANO MISSION EXECUTION

a. *Volcano Emplacement.* The decision to emplace a Volcano minefield (air or ground) will usually be made by the division commander or higher. The division commander, based upon the tactical situation and recommendations from division staff sections, will approve the emplacement of the Volcano mine system using a UH-60. The commander will provide his intent and guidance as to minefield type, delivery method, size, markings, and minefield duration.

b. *Mission Planning.* Mission planning for emplacement of air Volcano is done within the division G3 section. The ADE and the ADAO, with assistance from the division G3 (Air) and airspace management element, will conduct the mission planning. Upon receipt of the mission from the commander, the ADAO will provide a WARNORD to the aviation brigade, who will in turn give a WARNORD to the executing unit. The aircrews involved in the mission, along with assistance from the battalion staff, will develop flight routes and submit them to the ADAO for airspace deconfliction. The aircrews will load the system and determine fuel requirements.

c. *Mission Coordination.* Since this is a division mission, planning for the mission will be accomplished at division level. The ADE will develop the minefield plan, to include minefield type, observer plan, and marking plan. The ADAO, with assistance from the brigade and battalion S3, will develop a fire support and SEAD plan for the mission, using available assets. If the mission is in support of a deep operation, assets that may be used include field artillery, CAS, and attack helicopters. Employment methods for CAS and attack helicopters are the same as for an air assault. Throughout the planning process the brigade and battalion S3s must be involved to ensure that all combat systems are synchronized.

d. *Aircrew Briefing.* The flight crew will be briefed on the mission by the battalion staff, or they may be briefed directly by the division on the mission execution. The AB will be similar as that for an air assault, but will include minefield specific information, to include minefield marking procedures, the delivery technique, and the purpose of the minefield. It is important that the flight crews understand the purpose of the minefield. If the navigation systems (GPS, Doppler) onboard the aircraft fail, the pilots can still emplace the minefield that accomplishes the commander's purpose. Based upon a thorough map reconnaissance, enemy situation, and analysis of available assets, the pilots should select the delivery method with which they are most comfortable. The ADAO and the ADE should provide a

sketch of the minefield for the aircrews during the AB.

e. Logistics Planning. The division G4 section provides logistics support information to the DAO concerning the air Volcano mission. The DAO will identify which ATP or engineer mine dump will provide the mines for the mission. If the ATP/mine dump is notified early, the ammunition can be broken down and prepared for loading prior to the arrival of the aircraft. The location of the ATP/mine dump is passed to the ADAO, who sends it through the aviation brigade to the aircrews conducting the mission. At a predetermined time, the aircraft will reposition to the ATP/mine dump, where the canisters will be drawn and loaded into the dispensers by the flight crew or personnel from the aviation battalion sent to the ATP/mine dump.

f. Reporting Requirements. Upon completion of the mission, the aircrews conducting the mission must give the ADE the exact coordinates for the start point and end point of the minefield dispensing strip, and the exact time that the aircraft emplaced the minefield. The flight crews should use the SCATMINWARN reporting format found in [FM 20-32](#). This will allow the ADE to provide for proper marking and safe distance determination for the minefield. Reporting will be done as soon as possible following mine emplacement. Notification should be made using FM secure mode. If communications with the division are not possible, the aircrew must relay the information through the aviation battalion to the division. Following mission completion, the aircrew should verify that the ADE received the entire report from the pilots.



CHAPTER 9

STABILITY AND SUPPORT OPERATIONS

9-1. GENERAL

Aviation units have participated and can anticipate participating in SASO. Aviation's ability to rapidly deploy and operate in austere environments makes it an invaluable asset in SASO. Cargo and utility helicopters can expect to play a vital role in the conduct of SASO.

9-2. OPERATIONAL CONCEPT

a. SASO may require the deployment of the entire aviation brigade or just a portion of it. The aviation brigade may also be modified and a task force formed that encompasses elements from different units within the brigade. Cargo and utility helicopters can expect to be part of these task forces. C² is a function of the size and make up of the task force. Utility and cargo helicopters may be attached to another headquarters, or the utility and cargo battalion may become the task force headquarters.

b. Often, SASO focus on CS and CSS missions. Units participating in SASO will often work in concert with US and foreign military and civilian agencies, international organizations, and private organizations. Examples of US Army aviation SASO include transporting personnel, providing humanitarian aid, counterdrug operations, and special event support.

9-3 STABILITY AND SUPPORT OPERATIONS PRINCIPLES

a. Army aviation doctrine has long been based on the principles of war. SASO also have principles that guide the conduct of operations. The relative application of each principle will vary with each specific operation. Cargo and utility helicopter commanders must understand the implications of these principles as they may be designated as the task force headquarters. The SASO principles are--

- Objective. Direct every military operation towards a clearly defined, decisive, and attainable objective.
- Unity of effort. Seek unity of effort towards every objective.

- Legitimacy. Sustain the willing acceptance by the people of the right of the government to govern, or of a group or agency to make and carry out decisions.
 - Perseverance. Prepare for the measured, protected application of military capability in support of strategic aims.
 - Restraint. Apply appropriate military capability prudently.
 - Security. Never permit hostile factions to acquire an unexpected advantage.
- b. FMs [100-5](#), [71-100](#), [1-100](#), and [100-20](#) further define the principles of SASO.

9-4. STABILITY AND SUPPORT OPERATIONS MISSIONS

Army cargo and utility helicopters can expect to conduct many different types of missions in SASO. These missions can be conducted according to the planning considerations listed in the earlier chapters of this manual. The uniqueness of SASO makes it impossible to list all of the missions that cargo and utility aircraft will be tasked to accomplish, but following is a list of missions that can be expected in SASO:

- a. *Show of Force.*** A show of force is a mission carried out to demonstrate US resolve in which US forces deploy to defuse a volatile situation that may be detrimental to US interests. It may take the form of a combined training exercise, rehearsals, forward deployments of military forces, or introduction and buildup of military forces in a region.
- b. *Noncombatant Evacuation Operations.*** NEO relocates threatened civilian noncombatants from locations in a foreign country or host nation. NEO may be conducted in a peaceful environment or it may require force. Utility and cargo helicopters must be prepared to conduct these operations in a high threat environment.
- c. *Counterdrug Operations.*** Military efforts towards counter-drug support complement, rather than replace, the efforts of other US agencies. Utility and cargo aircraft support these missions by conducting reconnaissance and air moving counterdrug personnel.
- d. *Support for Insurgencies and Counterinsurgencies.*** US forces may directly support a host nation's counterinsurgency operations. Utility and cargo helicopters may support these operations by conducting air movement operations, C² operations, and air assaults. Aviation units in this type of operation can expect to be task-organized into a task force consisting of utility, cargo, attack, and cavalry assets.
- e. *Peace Enforcement.*** These operations are taken in support of diplomatic efforts to restore peace between hostile factions. Utility and cargo helicopters can expect to conduct air movement operations in a peace enforcement mission.
- f. *Air Assault.*** Air assault operations may be conducted as part of a SASO mission. Utility and cargo helicopters should be prepared to conduct limited air

assaults designed to achieve objectives such as securing key terrain, restoring order, and quelling civil unrest.

g. Disaster Relief. These operations may occur in CONUS or OCONUS. Army utility and cargo aircraft may be used to assist the civilian population in the event of natural disasters (hurricanes, earthquakes, fires, floods). Missions during these operations range from air movement of supplies and personnel to fire bucket missions.

h. Humanitarian Assistance. During peace operations, US forces may assist in providing humanitarian assistance to those in need. Assistance missions include air movement of food, water, and other critical supplies, air movement of personnel, to include medical personnel who will provide essential care to the local population.

i. Air Movements. Utility and cargo helicopters will conduct air movements during all types of operations. In SASO, units can expect to be tasked to move troops, supplies, equipment, diplomats, allied forces, and media.

j. Command and Control. In SASO, C² is a critical function. Since the organization of a JTF may consist of troops from different units, C² is essential. Utility aircraft can assist in the effective control of SASO by providing the JTF and unit commanders with a platform for conducting C² operations.

k. Special Event Support. Utility and cargo helicopters may be called upon to support special events within CONUS and OCONUS. Examples of these types of missions include support for sporting events, Olympic Games, and support for dignitaries, both US and foreign. Support missions consist of providing aircraft for air movements of antiterrorist teams, supporting media, movement of security personnel, and movement of supplies and equipment.

9-5. STABILITY AND SUPPORT OPERATIONS PLANNING CONSIDERATIONS

Once given a mission to conduct a SASO, the cargo and utility helicopter commander faces challenges that may be different from those involved in conventional operations. Some of the planning factors that commanders must consider are listed below.

a. Mission Analysis. Perhaps the greatest obstacle for the commander to overcome in SASO will be defining the mission for his unit. When the unit receives the OPLAN/OPORD, mission analysis begins. Careful mission analysis will allow the commander to determine if he is task organized correctly to meet the intent of the JTF commander. During the mission analysis, the aviation commander must pay particular attention to limitations placed upon him by the ROE or political considerations.

b. Task Organization. Task organization for a SASO is METT-T driven. The commander must assess the battalion's capabilities versus the mission he is given. He must determine if the task organization is capable of accomplishing the assigned missions. If not, the commander must notify the JTF commander and request to modify the task force so that the JTF commander's mission and intent can be met by the cargo and utility helicopter unit.

c. *Command Relationship.* A cargo and utility helicopter unit may often deploy on a SASO without their parent brigade headquarters, or a company may be attached to another battalion headquarters to form an aviation task force. Further, it is possible that the aircraft may work for another service or US nonmilitary agency, such as DEA and FBI. It is critical that the command relationships for the SASO be established early. A clear understanding of the C² relationship will help reduce confusion throughout the operation. Determining the command relationship early will allow the aviation unit to integrate with the headquarters they are attached to early, resulting in a cohesive organization during the execution of the SASO.

d. *Advanced Party Operations.* Advanced party personnel need a comprehensive overview of their unit's mission, commander's intent, capabilities, and requirements prior to deployment. Advanced party personnel must interface with the gaining command or JTF as well as with the local population. Advanced party personnel should be carefully selected by the commander, and the makeup of the party is METT-T driven. For example, deploying to another country with an undeveloped logistics base may require the advanced party to be heavily logistics weighted and contain foreign language specialists, while other missions within CONUS, such as counterdrug operations, can have an advanced party weighted with operational personnel. Whichever the commander chooses, the advanced party must receive guidance and focus from the commander prior to deployment. The advance party must also keep the commander informed as to their actions and the current situation in the AOs.

e. *Split-Based Operations.* The cargo and utility commander will often deploy on SASO with a portion of their unit and into a theater that has an immature logistics base. Often, logistics operations will be conducted in theater and from the unit's home station. This is termed split-based operations. The cargo and utility commander who deploys on an operation that is conducting split-based operations must consider the type of support that must be provided from home station. The commander must pay special attention to communications between the theater of operations and the home station and to the transportation means available to provide a timely flow of logistics to the deployed unit.

f. *Deployment.* SASO deployments deserve special consideration because many times the aviation battalion, or elements of the battalion, will deploy alone and not with their parent organization. The commander must ensure that the deploying units are fully supported during the preparation and execution phases of the deployment. Special emphasis for deployment should be placed on the following areas:

(1) *Early involvement of movement control personnel.* Commanders must integrate early with the organizations providing movement control. Early coordination will ensure that that rail and ship operations are conducted smoothly.

(2) *Packing lists.* Units need to identify a packing list and stick by it. Shipping containers will be based upon the packing lists submitted by the units. Careful attention needs to be placed on developing load plans that make the best use of the space available in the containers provided.

(3) *Liaison.* SASO often require units to do missions for which they are not trained. Commanders must select LNOs and deploy them early to critical locations to provide the commander with information and to assist the unit in conducting a smooth deployment. Critical locations requiring LNOs include departure airfields, sea ports, rail heads, and higher headquarters.

(4) *Movement personnel.* All units, regardless of their home station location, may deploy to another theater to conduct SASO. Self-deployment is not always possible, and units may require ships or strategic aircraft to move their assets. All units should have qualified load planners and personnel trained to certify hazardous cargo for movement.

(5) *Loading teams.* Cargo and utility unit commanders must anticipate the need for teams to load equipment on to ships or planes. They must designate them early and properly train them prior to mission execution.

g. *Logistics.* During SASO, logistics is a critical element. The logistics base may be well developed or may be nonexistent. Commanders must determine the logistics available to support the mission. The priority for logistics in SASO goes to class III, class V, class IX, and class I.

(1) *Class III (petroleum, oil, and lubricants).* Host nation POL may or may not be available to supporting aircraft. Advanced party operations must include determining availability of refuel in theater. The advanced party may have to establish contracts with host nation fuelers to provide fuel for aviation tankers or provide fuel from host nation sources. If fuel is not available in theater, the commander must coordinate with the higher headquarters for fuel resupply.

(2) *Class V (ammunition).* Commanders must consider how their aircraft will get ammunition for the M60D door guns. Additionally, ammunition may be required for force protection within the aviation AA. Commanders and staffs must plan for and request adequate class V. Class V requirements will be based on an analysis of the threat. Advanced parties should integrate with the higher headquarters to establish class V accounts and to determine the procedures for class V requisition and resupply.

(3) *Class IX (repair parts).* Class IX accounts must be established with the higher headquarters as soon as possible. The advanced party should make all necessary arrangements for class IX parts ordering before the unit arrives. For a SASO without an established system for ordering class IX parts, the unit should arrange for alternate methods of receiving repair parts.

(4) *Class I (food).* Class I accounts are another critical logistics element that the advanced party must set up prior to the arrival of the unit. Coordination should be made with the higher headquarters for establishing class I contracts with host nation assets.

h. Force Protection. The aviation commander must consider force protection as essential throughout the conduct of the SASO. External security assets must be requested if needed. Coordination for any external security force should be accomplished prior to deployment to the AOs. Commanders must make an assessment of their AA. Staff operations must consider the defense of the AA. Careful staff planning and coordination with higher headquarters will ensure that the soldiers are well protected.

i. Rules of Engagement. ROE are designed to control the application of force. These rules stipulate under what conditions US soldiers can use force. The ROE will be prepared and issued at the theater, JTF, or national level. The aviation unit commander must clearly understand the ROE and ensure that all the soldiers in the unit understand it also. All personnel should be briefed on the current ROE in effect prior to executing a mission.

j. Host Nation Considerations. Civil and military laws, airspace procedures, radio frequency usage, ground convoy clearances, flight restrictions, local customs, and host nation contracting are all factors the commander must consider prior to executing SASO in another country. The aviation commander must adapt to local procedures to accomplish his mission.

k. Landing Zones. Adequate LZs may not be available for the conduct of SASO missions. This is especially critical in urbanized terrain. The aviation staff must use available resources (local population, imagery, photos, higher intelligence sources) as well as their own area analysis (map reconnaissance, actual reconnaissance) to determine the location, adequacy, and capabilities of potential LZs in the SASO area.



CHAPTER 10

COMBAT SERVICE SUPPORT

10-1. GENERAL

Combat service support is the support provided to sustain combat forces, primarily in administrative and logistics. It includes administrative services, chaplain services, civil affairs, food service, finance, legal services, and medical services. It also includes maintenance, supply, and transportation. This chapter focuses on CSS planning considerations for utility and cargo helicopter units.

10-2. PLANNING

Combat operations planning and CSS planning must be done in conjunction with operational planning, so that the CSS plan supports the operational plan. Successful utility helicopter unit operations require timely reports that reflect the unit's CSS status. The aviation brigade supporting the utility and cargo helicopter unit is employed without an FSB; therefore, tactical and CSS planning must include aviation unit support packages throughout the division's AO. The aviation brigade in the heavy division does have an ASB. This battalion provides GS maintenance for ground systems, aviation intermediate maintenance, and supply and transport activities. It does not provide a level II medical facility like the FSB. The DISCOM must be prepared to provide support to the utility helicopter unit.

10-3. FUELING OPERATIONS

Fuel (class IIIA) is a critical commodity for all utility helicopter unit operations. Unit aircraft consume large quantities of fuel during each mission. To ensure a continuous unit readiness posture, the unit's logistics planners must accurately plan for and constantly monitor fuel consumption.

a. Requesting Fuel Supplies. The unit initiates periodic status reports on bulk POL products. These reports are processed through the aviation brigade S4 who consolidates user needs and coordinates delivery through the DMMC. When possible, corps tanker assets will direct bulk aviation fuel to the utility and cargo helicopter units or to the closest support battalion fuel distribution point. If an emergency fuel shortage arises, organic unit tankers, or aircraft, can go to the division airfield where the MSB maintains aviation fuel. Corps cargo and utility aircraft may also be available for limited aerial resupply fuel from corps sources.

b. Calculating Requirements.

(1) Fuel requirements are based on both daily and mission needs. Daily needs are figured by multiplying the estimated daily hours each aircraft will fly by the consumption rate of that particular aircraft. That total is multiplied by the total number of aircraft in the unit.

(2) The consolidated fuel total of unit aircraft is the daily fuel quantity that must be requisitioned. Mission needs are figured by applying the same formula used to calculate daily needs, except that mission-available aircraft totals are used instead of organic totals, and mission hours are substituted for daily hours. Considered the fuel that is in aircraft tanks when the mission begins, fuel totals derived may be adjusted. This gives the true amount of fuel the FARP requires to support a given mission. Table 10-1 shows fuel consumption rates used in calculating daily and mission needs of an AHB. For example, the mission is expected to last 5 hours. There are 10 UH-60s available to participate. The minimum fuel required for the mission is calculated as follows: 5 hours x 145 gph x 10 UH-60s = 7,250 gallons. Assuming all aircraft are full of fuel at the start, equaling 10 x 362 gallons or 3,620 gallons, then 7,250 minus 3,620, or 3,630 gallons will need to be provided.

Table 10-1. Aircraft fuel consumption rates

Aircraft	Fuel Consumption (gph)
UH-60	145
UH-1	90
CH-47D	385

Legend: See the glossary for acronyms and abbreviations.

NOTE: Fuel consumption rates are approximate. Actual rates will be based on missions, environmental conditions and aircraft factors. The S4 and the POL platoon leader must coordinate with the S3 and the units to determine average fuel consumption rates for the theater and the conditions in which they are operating.

(3) Accurate fuel planning requires continuous coordination between the S3, S4, and the POL platoon leader. The S4 must be integrated into operational planning so that sufficient fuel can be requested, and available, for the mission.

10-4. MAINTENANCE AND RECOVERY

The utility and cargo helicopter unit has an organic unit maintenance element. However, the large number of aircraft, ground vehicles, and other critical pieces of equipment necessitates additional maintenance assistance from outside the unit (DS, GS, depot support) to sustain operations. The MAC in the equipment manual assigns the maintenance functions. It explains at what maintenance level particular tasks are performed. The MAC must always be referred to before a maintenance task is started. Maintenance functions include inspecting, testing, servicing, repairing, requisitioning, rebuilding, recovering, and evacuating equipment. Repair and recovery are accomplished as far forward as possible, and at the lowest capable level. When equipment cannot be repaired on site, it is moved only as far to the rear as necessary for repair. This concept insures timely repairs and keeps the maximum amount of equipment operational. The utility and cargo helicopter unit uses the principles of flexible unit structure, direct support, and general support to implement this concept. The key to maintenance management is sound planning and establishing a disciplined maintenance management system to ensure that equipment remains operational. Additionally, the flow of DA Forms 2404 must be planned with an established maintenance tracking system developed and adhered to.

a. Ground Maintenance.

(1) Unit maintenance. Unit maintenance is performed by organizational maintenance personnel, vehicle or equipment operators, and crews. Unit maintenance includes scheduled and unscheduled unit maintenance repair and PMCS, which are performed according to the PMCS table in the equipment manual. The table specifies when, and under what condition, each preventive maintenance check and service is performed. Generally, the operator and/or crew, or the using unit, is primarily responsible for performing PMCS. The purpose of PMCS is to improve the operational readiness of equipment through preventive maintenance and early diagnosis of problems.

(2) Direct support maintenance. DS maintenance units provide one-stop maintenance services for the supported units. They provide extensive maintenance support to the assault helicopter unit, including component repair and repair parts supply support. DS maintenance units at the division level are located in the ASB and the FSB, located in the BSA.

(3) General support maintenance. A GS maintenance unit is characterized by an extensive component repair capability. It supports the supply system within the theater by repairing damaged systems for issue through the supply system as class II, VII or IX items. This level of maintenance is normally found at division and higher. The DISCOM contains a GS maintenance company that is located in the DSA.

(4) Depot maintenance. Army Materiel Command depots or activities, contractors, and host nation support personnel perform depot maintenance to support the supply system. Depot tasks are outlined in [AR 750-1](#). These tasks must also be outlined in a memorandum of understanding when they are performed in the theater of operations. Depot maintenance is production-line oriented and is performed in fixed facilities in CONUS and the theater of operations. Repair parts supply for depot maintenance is limited to items that are needed to support assigned maintenance missions.

b. Aviation Maintenance. Aviation maintenance operations continue around the clock. The governing concept is to "replace forward, repair rear," to enable the utility helicopter unit to return aircraft to the battle rapidly. Damaged or inoperable aircraft that require time-consuming repairs are handled in more secure areas toward the rear. [TM 1-1500-204-23-1](#) outlines general aircraft maintenance procedures. DA Pamphlet 738-751 contains detailed information on the Army maintenance management system.

(1) Aviation maintenance. Aviation maintenance functions are divided into two categories--scheduled and unscheduled.

(a) Scheduled maintenance. The critical aspect here is the continuous coordination and involvement between unit operations and unit maintenance to accomplish the scheduled maintenance, while also accomplishing the unit's mission. This cooperative effort requires a daily exchange of information to reveal the continuously changing situation that exists in any utility and cargo helicopter unit. Scheduled maintenance includes predetermined cyclic inspections of aircraft systems and component replacement. These events are scheduled either on a calendar or flying-hour basis.

(b) Unscheduled maintenance. Unscheduled maintenance is required when an aircraft system, or component, malfunctions or fails unexpectedly. It is also required to correct damage incurred as a result of improper operation or battlefield activity. Because unscheduled maintenance cannot be predicted, units are doctrinally and organizationally prepared to make unscheduled repairs as needed.

(2) Aviation support system structure. The support system comprises a three-level structure--AVUM, avim, and depot maintenance. Depot maintenance is coordinated at the AVIM level or higher and is discussed in [FM 1-500](#). Specific organizational structures vary somewhat, depending on whether they are in a division (light or heavy) or corps. However, the basic concepts of aircraft maintenance discussed below are generally applicable in all organizations.

(a) Aviation unit maintenance. All operational aviation units are responsible for AVUM. The objective of unit maintenance operations is to ensure that the maximum number of fully mission-capable aircraft is available to the battlefield commander. The general concept is for crew chiefs assigned to specific aircraft to perform daily servicing and inspections, while also performing normal repairs involving simple parts exchange. Scheduled maintenance, other than daily inspections and the more time-consuming operator-level repairs, is normally done by the AVUM platoon or company. The AVUM platoon/company must be prepared to accept aircraft from the battle area for immediate repair or to make on-site repairs. These on-site repairs are completed by contact teams. The AVUM platoon/company recommends whether the aircraft should be repaired on-site, or evacuated to the rear. If the repairs are minor and require no

specialized skills, only repair parts are brought forward. Repair time is a major factor in determining whether evacuation is necessary, as maintenance support teams may be able to make on-site repairs faster than the aircraft can be evacuated. The bulk of the platoon/company mission is scheduled maintenance, component repair, repair part requisition and storage, and major unscheduled repair. The AVUM technician maintains close contact with the forward element of the platoon/company to ensure that the maintenance status of the unit aircraft is coordinated and accurately communicated. The platoon/company must maintain the highest degree of mobility and coordinate continuous AVIM support, when needed. Shortage of repair parts may require the utility and cargo helicopter unit commander to use battle-damaged, or unserviceable, aircraft as a source for repair parts during combat operations. The intensity of combat, need for operational aircraft, and availability of the repair parts through the supply system will dictate the extent that operational substitution is necessary.

(b) Aviation intermediate maintenance. AVIM will provide intermediate level maintenance for AVUM and operating organizations. AVIM serves as the connection between AVUM and depot(s) located away from the battlefield. The goal of the AVIM is the same as that of the AVUM; to provide the battlefield commander with the maximum number of fully mission-capable aircraft.

(3) Additional maintenance considerations.

(a) Night operations. Army operational doctrine demands around-the-clock operations. This requires a fully productive, continuously running maintenance capability. Working on aircraft and vehicles day and night dramatically shortens repair time and maximizes the number of mission capable aircraft. This around-the-clock maintenance capability ensures that aircraft can be used on successive days, or nights, by completing the required maintenance during those alternate hours. Flexibility is key to a successful operation. The closer to the FLOT a unit operates, the more restrictive noise and light discipline becomes. This is a factor in determining whether an aircraft is repaired on-site or evacuated to a more secure area. The terrain that exists in the AO is also a factor in night operations. For example, night operations in a desert environment can be detected from a far greater distance than those in a wooded environment. A single overall concept for night maintenance operations is not feasible and requires each organization to establish and alter its plan according to environmental conditions and changes in the threat. Successful mission completion must also include human factors, such as crew endurance criteria for maintenance personnel, which should be included in the company's tactical SOP. In short, night operations must be thoughtfully planned and carefully considered, so as to complete the mission, while avoiding enemy detection.

(b) Environment conditions. Aircraft maintenance operations must be carefully planned to permit completion in any environment,

including the desert, jungle, mountains, or extreme cold climate. [FM 1-500](#) lists the special considerations for aircraft operating in such environments. Finally, commanders must also consider the--

- Communication restrictions.
- Special shelter requirements.
- Specialized equipment and clothing requirements.
- Mobility and transportation requirements.
- Physiological effects of the environment on all personnel.
- Increased stockage levels of filters, bearings, and seals necessary for operation in the harshness of any environment with an unusual amount of wind and sand.

c. Ground Vehicle And Equipment Recovery. The goal of this operation is the timely return of equipment to operational status with the least expenditure of resources. This will require careful coordination of all parties. Recovery operations are normally conducted according to certain general principles. These principles are discussed below.

(1) Initiating the recovery. This action begins where, and when, the item becomes disabled. When the operator detects an inoperable condition, he must assess the damage or problem and initiate action based on his assessment and the tactical situation. Using the unit SOP, he then informs the chain of command, considering all factors such as communication ability, his location, and the location and availability of recovery equipment and personnel.

(2) Self-recovery. The utility and cargo helicopter unit is responsible for the recovery of its disabled equipment. When the unit lacks the physical means to recover an item, it requests assistance from the supporting maintenance element.

(3) Task organizing. The commander organizes recovery resources to best support the unit's mission. The type and quantity of supported equipment, as well as the tactical situation, may require the reorganization of recovery assets.

(4) Maintenance. Recovery operations are coordinated with the maintenance effort. Maintenance personnel repair equipment as far forward as the tactical situation, the amount of damage sustained, and the availability of resources will allow. The maintenance time required to repair the equipment aids in determining the method of recovery or repair and the maintenance activity level to which the equipment is to be returned.

(5) Recovery equipment. The proper recovery equipment must be employed to perform the recovery. Wreckers are normally used to recover wheeled vehicles. Selection of the proper equipment becomes critical as the work load increases.

(6) Fix forward concept. Recovery vehicles do not return vehicles farther to the rear than is absolutely necessary. Usually, equipment is recovered to

the supporting maintenance collection point. This concept maximizes availability of the maintenance recovery equipment and ensures the most timely return of the damaged equipment to the owning unit.

(7) Ground guides. Accurate location information is provided to the recovery manager and crews. Ground guides may be required when specific location information is not available, or when the tactical situation is not well defined.

(8) Multiple vehicle recovery. Multiple recovery involves towing more than one disabled vehicle at a time. Careful route selection is critical to ensure the safe recovery operation, such as avoiding steep grades that would exceed the braking capability of the tow vehicle or unusually sharp corners that would impede the recovery.

(9) Recovery prioritizing. With limited recovery vehicles, the commander must establish the priority sequence according to the tactical situation and the subsequent need for any item. Usually, combat vehicles are recovered before a tactical vehicle. A list, in descending order, follows: the first items should be classified items, followed by items that require minimal repair time, then items requiring long recovery or repair times, finally recovering contaminated items as well as those requiring repair that is uneconomical or enemy equipment.

d. Aircraft Recovery. Combat operations result in a greater demand for operational aircraft and a large increase in the number of flying hours. These increased requirements will be complicated by higher attrition and battle-damage rates, which create shortages of repair parts and replacement aircraft. To offset these shortages and to maintain an effective combat aviation force, the rapid recovery and repair of aircraft is essential.

(1) Aircraft recovery responsibility. The owning unit is responsible for aircraft recovery. The unit must coordinate the recovery effort with the units involved, specifically the AVIM and the AVUM. The operation also must be coordinated with any organization that may provide aircraft or vehicle assets necessary for the recovery, such as the CH-47 company.

(2) Aircraft recovery team. The AVIM provides the key members of the recovery team. The team includes personnel who are trained and approved to rig the aircraft for air transport. They also advise the recovering aircraft flight crew on the details of the flight, such as maximum airspeed, load configuration, tandem or single hook load. The AVIM will also provide the necessary equipment, including sling kits and the appropriate FMs, for the recovery. This role of the AVIM cannot be overstated, if the inoperable aircraft is to be successfully recovered with no further damage. The AVUM can assist in this effort, but the critical expertise belongs to the AVIM. Each team usually includes this AVIM slingload expert, an aircraft maintenance officer, a forward repair and recovery team chief, a technical inspector, and any additional personnel deemed necessary to assist.

(3) Options. The maintenance and recovery team must consider several factors in determining the best course of action, including the location of

the damaged aircraft, the tactical situation, and the time available for the recovery effort. The team may decide to defer further maintenance, effect minimal repairs, and fly the aircraft to the rear. They might also decide to rig the aircraft for air transport by sling loading, or they may decide to selectively cannibalize the aircraft, destroy and abandon it according to SOPs and/or approving authorities.

10-5. PERSONNEL SERVICE SUPPORT

Personnel assigned to the PAC, battalion aid stations, and the UMT perform personnel service support functions. Those companies designed as "stand alone" companies (heavy helicopter company and light utility company) have clerks at the company level that are equipped to conduct these functions. Personnel services support functions fall into three general categories--combat critical, health service support, and sustainment. The combat critical and health service support functions must happen regardless of combat intensity, whereas the sustainment functions can be curtailed, suspended, or postponed during the intense periods.

a. *Combat Critical.* These functions will have priority not only during combat, but also preparation for combat. They include the following:

(1) *Personnel accounting and strength reporting.* This includes updating the unit battle roster, based on duty positions for the unit TOE, and preparing and forwarding the personnel status roster. The personnel status roster is submitted daily and after significant changes in unit strength.

(2) *Processing replacements.* These actions include assigning replacements based on critical leadership assignment. They also include performing administrative and personnel actions such as inprocessing personnel, preparing SIDPERS transactions, updating battle rosters, and briefing replacements on the tactical situation and unit SOPs. Battalion and brigade S-1s should have developed a detailed SOP for inprocessing replacements.

(3) *Casualty reporting.* These actions include reviewing casualty feeder reports and witness statements for completeness and accuracy, checking the battalion aid station casualty treatment log to ensure all casualties have been reported, and forwarding the casualty report.

(4) *Media operations.* This should include briefing all soldiers on communicating with the media, including legalities, permitted topics, and those items of information that cannot be discussed. In this age of communication, media operations must have a priority, so as to not jeopardize the mission.

b. *Health Service Support.* These functions also have priority during combat and preparation for combat. They include the following:

(1) Unit level health service support personnel have the primary mission of preventing illness, providing emergency and routine medical treatment, and

medically evacuating the sick, injured, and wounded. Medical personnel are responsible for supervising the training of first aid, buddy aid, and combat lifesaver skills. Additionally, medical personnel provide assistance in preventive medicine measures, such as field sanitation and personal hygiene. Limited health support services resources in the unit require additional personnel be trained in combat lifesaver skills to assist medical personnel in the initial treatment of casualties.

(2) Medical aid personnel assigned to the HHC medical treatment squad/section accompany FARP personnel when they move forward. One medical aid person should be stationed at each FARP location. The flight surgeon or physician's assistant assigned to the aviation battalion should accompany treatment teams that move forward.

(3) Provisions for a S-1 must be included in the planning process. The S-1 should consider the following: the estimated casualty work load, the augmentation of medical personnel, preplanned patient collecting points and ambulance exchange points, and the augmentation of medical evacuation resources by corps level evacuation assets.

c. Personnel Services. These support actions may be curtailed, suspended, or postponed during intense periods of combat. These actions include evaluation reports, SIDPERs transactions, awards and decorations, and promotions or reductions. They also include the following:

(1) Finance services. The degree of financial services varies with the tactical situation. In mid- and high-intensity conflicts, regularly established paydays are suspended in the theater of operations.

(2) Postal services. The corps direct support postal unit provides postal services for the utility and cargo helicopter units assigned.

(3) Religious support. Comprehensive religious support is provided by the unit ministry team of the aviation battalion. Support provided by this team includes the normal religious services. The team's mission provides pastoral care in nurturing the living, caring for casualties, and honoring the dead. The team should also advise the command on moral, ethical, and religious issues affecting the unit's mission. Religious support is covered in [FM 16-1](#).

(4) Legal services. These actions include processing UCMJ actions, etc. They also include processing Article 32 and 15-6 investigations, assembling investigation reports, and witness statements.

(5) Morale and welfare services. These activities include determining the needs and interests of the soldiers, obtaining support from agencies, and obtaining recreation related supplies. Also, equal opportunity counseling and drug and alcohol counseling are included.

(6) Public affairs services. This will include disseminating information and published material received from higher headquarters. It also includes

implementing a hometown news release program.

10-6. AMMUNITION

a. *Basic Load.* This is the quantity of ammunition authorized by the theater commander for wartime purposes and required to be designated for, and carried into, by a unit. The basic load provides the unit with enough ammunition to sustain itself in combat, until the unit can be resupplied. Ammunition basic load quantities will not exceed quantities the unit is capable of moving into combat in the first lift using organic transportation and equipment.

b. *Ammunition Requests.* Ammunition is normally requested by the battalion S-4 on a DA Form 581.

c. *Ammunition Transfer Point.* At the Division, all FSBs can run one ATP. These ATPs are located in the BSA and contain ammunition to support all the division units operating in the brigade area.



APPENDIX A

UTILITY AND CARGO AIRCRAFT CHARACTERISTICS

A-1. PURPOSE

The purpose of this appendix is to list aircraft characteristics and planning considerations for the use of utility and cargo aircraft. It is not designed to cover all aircraft characteristics, but those deemed critical in the planning of successful utility and cargo helicopter operations.

A-2. UH-60A/L

This section discusses aircraft characteristics, capabilities and limitations of the UH-60A/L Black Hawk helicopter.

a. Characteristics.

- (1) The UH-60A/L is a twin-engine, single rotor helicopter. Primary mission capability of the helicopter is air assault and air movement. Secondary missions include SASO, CSAR, C² platform, CASEVAC, and air Volcano (mine setting) during day, night, visual, and instrument conditions.
- (2) The aircraft is approximately 65 feet long with, approximately, a 54-foot main rotor span.
- (3) Maximum gross weight for the UH-60A is 22,000 pounds. Maximum gross weight for the UH-60L is 22,000 pounds. (With an external load exceeding 8,000 pounds, the maximum gross weight is 23,500 pounds.)
- (4) Maximum airspeed is 193 knots with a normal cruise speed of 130 knots. However, the speed for any mission will vary greatly depending on load configuration (internal or external), time of day, weather conditions, METT-T, etc.
- (5) The minimum crew for tactical missions is four, two pilots and two crew chiefs. It is essential that two crew chiefs be used when conducting air assault, NVG operations, and sling loads.
- (6) The aircraft can be operated in light or moderate turbulence.
- (7) The aircraft can be operated in IMC.

b. Capabilities.

- (1) The UH-60A cargo hook can carry external loads up to 8,000 pounds. The UH-60L cargo hook can carry external loads up to 9,000 pounds.
- (2) With seats install, the UH-60A/L can carry up to 11 combat-loaded troops. With seats removed, the UH-60A/L can carry up to 16 combat-loaded troops or up to 20 troops

without full combat load.

(3) Aircraft internal loads can be up to maximum gross weight, with a limitation of aircraft space and loading not to exceed 300 pounds per square foot.

c. Limitations.

(1) UH-60A/L endurance is 2.5 hours without external fuel tanks and 5.0 hours with external fuel tanks.

(2) UH-60A/L combat radius is approximately 225 kilometers.

(3) UH-60A/L combat radius, with external fuel tanks installed, is approximately 450 kilometers.

(4) The UH-60A/L shall not be started or shutdown in winds (including gusts) in excess of 45 knots.

(5) UH-60A/L helicopters with the following equipment installed can fly into trace or light icing conditions; however, flight into light is not recommended without the blade deice kit:

- Windshield anti-ice.
- Pitot heat.
- Engine anti-ice.
- Engine inlet anti-ice modulating valve.
- Insulated ambient air sensor.

For flights into moderate icing conditions, all the equipment listed above and the blade deice kit must be installed and operational.

A-3. CH-47D

This section discusses aircraft characteristics, capabilities, and limitations of the CH-47D Chinook helicopter.

a. Characteristics.

(1) The CH-47D is a twin-engine, tandem rotor helicopter designed for transportation of cargo, troops, and weapons during day, night, visual, and instrument conditions.

(2) The aircraft fuselage is approximately 50 feet long. With a 60-foot rotor span, on each rotor system, the effective length of a CH-47D (with blades turning) is approximately 100 feet from the most forward point of the forward rotor to the most rearward point on the aft rotor.

(3) Maximum gross weight is 50,000 pounds.

(4) Maximum airspeed is 170 knots with a normal cruise speed of 130 knots. However, speed for any mission will vary greatly depending on load configuration (internal or external), time of day, weather conditions, METT-T, etc.

(5) The minimum crew for tactical operations is four, two pilots, one flight engineer, and one crew chief. For more complex missions, such as NVG operations and air assaults, commanders may consider using five crew members and add one additional crew chief.

(6) The aircraft can be operated in light or moderate turbulence.

(7) The aircraft can be operated in IMC.

b. Capabilities.

(1) **Cargo hook (external load).** The limits presented below are structural limitations only.

(a) The structural limit of the forward and aft hook is 17,000 pounds.

(b) The maximum single load that can be suspended as a tandem load from the forward and aft hooks is 25,000 pounds.

(c) The center cargo hook is limited to a maximum load of 26,000 pounds.

(2) **Load configuration.** Consideration must be given to the advantages and disadvantages of any particular external load configuration. For example, while it is generally true that a tandem load will ride better and permit a higher airspeed, it is also true that a tandem load usually requires ground personnel to attach the load to the aircraft. All appropriate references must be researched to insure compliance with any directives regarding load configuration, that is, many loads allow center hook or tandem hook attachment.

(3) **Internal load.**

(a) Troop seating arrangement for up to 31 fully equipped ground troops is provided in the CH-47D. This is broken down by 10 three-man seats and 3 one-man seats (See Figure A-1). This total number varies greatly due to the configuration of the aircraft's interior. For example, is the aircraft equipped with a single ERFS tank, or is the crew required to carry additional survival equipment due to extreme weather? This factor requires extensive consideration before committing a specific number of aircraft with a specific ACL to a given mission. Additionally, the troop commander's jump seat may be available, but is unwieldy and time consuming to use. Troops are normally loaded and unloaded through the lowered aft cargo door and ramp.

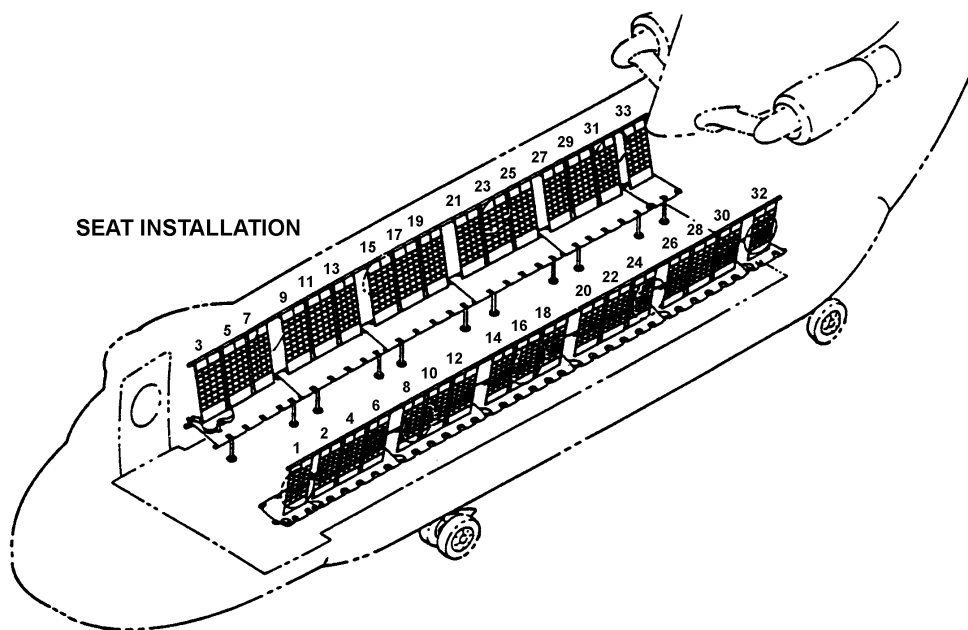

Figure A-1. CH-47D seating arrangement

(b) The CH-47D litter arrangement provides for up to 24 litters. These 24 litters are configured in six tiers of four litters each (see Figure A-2). In this 24-litter configuration, it may be possible to leave the three, one-man seats in position. It is not necessary to remove the troop seats to install the litters.

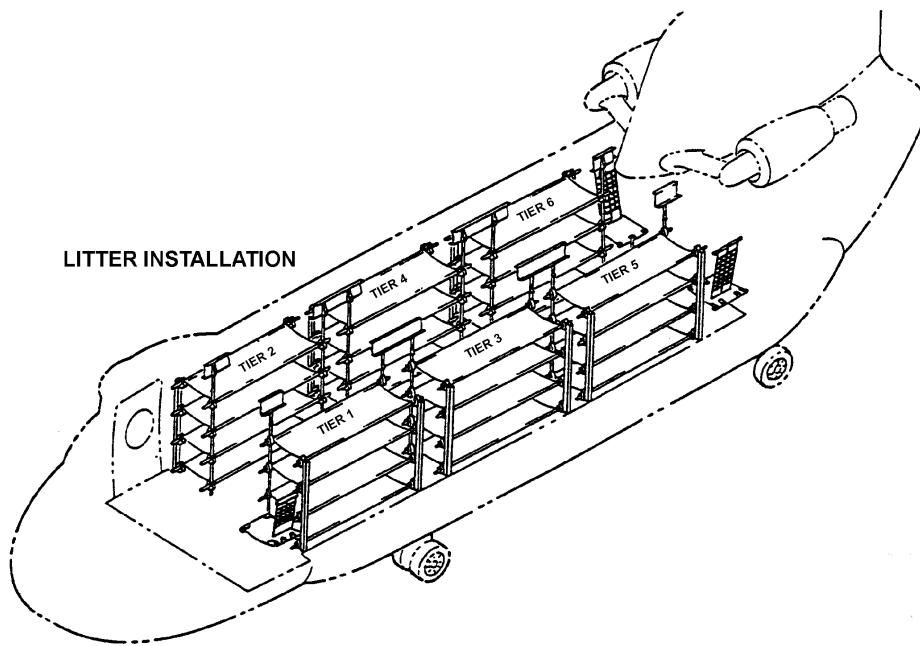

Figure A-2. CH-47D litter configuration

(c) **Cargo loading (internal).** The dimensions of the cargo compartment are 366 inches long, 90 inches wide, and 78 inches high. These dimensions are uniform throughout the cargo compartment. However, there are some restrictions when fitting items through the two doors; reference [TM 55-1520-240-10](#). This same TM should be referenced for detailed information on tie-down points, etc.

(d) **Helicopter internal cargo handling system.** CH-47D units have the necessary equipment for four aircraft to be equipped with HICHS. This system provides for quick loading, securing, and unloading of palletized cargo. The system generally uses either the 463L pallet (up to 3 simultaneously) or warehouse wooden pallets (up to 10, depending on size). While cargo can be carried without the use of the HICHS, this system expedites the loading and unloading process.

(e) **Winch/hoist system.** The CH-47D is equipped with a 3,000 pounds capacity hydraulically operated winch that can be employed in either of two modes. For the purpose of loading and unloading cargo internally, this system is used in the CARGO mode. This mode permits the winching of cargo up to 3,000 pounds on a straight-line pull, or up to 12,000 pounds, with the aid of pulley blocks. The remaining mode, described as the RESCUE mode, permits the use of this system as a rescue hoist (up to 600 pounds) and is not used for cargo loading.

b. Limitations.

- (1) CH-47D endurance is 2.5 hours without ERFS tank(s) and 4.0 hours with one ERFS tank installed.
- (2) The combat radius of the CH-47D is approximately 225 kilometers.
- (3) The combat radius of the CH-47D, with one ERFS tank installed, is approximately 350 kilometers.
- (4) The aircraft shall not be started or shutdown in winds (including gusts) in excess of 30

knots.

(5) Continuous flight in light-icing conditions below 5 degrees C is not recommended since blade damage can occur from asymmetric ice shedding.

A-4. UH-1H

This section discusses aircraft characteristics, capabilities, and limitations of the UH-1H helicopter.

a. *Characteristics.*

(1) The UH-1H is a single engine, single rotor helicopter. Primary mission capability of the helicopter is air movement of supplies and personnel. Secondary missions include SASO, air assault, and C² operations under day, night, visual, and instrument conditions.

(2) The aircraft is approximately 57 feet long with a 48-foot main rotor span.

(3) Maximum gross weight is 9,500 pounds.

(4) Maximum airspeed is 124 knots (roof mounted pitot tube) or 112 knots (nose mounted pitot tube), with a normal cruise speed of 100 knots. However, the speed for any mission will vary greatly depending on the load configuration, time of day, and weather conditions.

(5) The minimum crew for tactical operations is three, two pilots and one crew chief.

(6) The aircraft can be operated in IMC.

b. *Capabilities.*

(1) The UH-1H cargo hook can carry external loads up to 4,000 pounds.

(2) With seats install, the UH-1H can carry up to 11 combat-loaded troops.

(3) Aircraft internal loads can be up to maximum gross weight, with a limitation of aircraft space and loading not to exceed 100 pounds per square foot.

c. *Limitations.*

(1) The UH-1H endurance is approximately 2.5 hours without auxiliary fuel tanks and approximately 6 hours with auxiliary fuel tanks. **Note:** The auxiliary fuel tanks in the UH-1H are mounted internally, which reduces the passenger and cargo carrying capacity of the helicopter.

(2) The aircraft shall not be started with winds in excess of 30 knots or a gust spread of 15 knots or greater.

(3) Intentional flight into known moderate icing conditions is prohibited.

(4) Intentional flight into moderate turbulence is not recommended. Flight into severe or extreme turbulence is prohibited.

A-5. STRATEGIC AIR MOVEMENT PLANNING FACTORS

Figure A-3 shows the strategic air movement planning factors for UH-60 and CH-47.

<u>UH-60</u>	<u>C5A</u>	<u>C141</u>	<u>C17</u>
Maximum Load Capacity	6 acft	2 acft	4 acft
<u>TIMES</u>			
Disassemble	1.0 hr	3.0 hrs	2.0 hrs
Load	1.5 hrs	1.0 hr	1.0 hr
Unload	1.5 hrs	1.0 hr	1.0 hr
Assemble	1.5 hrs	3.0 hrs	2.0 hrs
NOTE:	<ol style="list-style-type: none"> 1. Times above represent one aircraft, 6 person crew 2. Figures do not include 0.5 hrs. for test flight 3. Major disassembly work: C5A - remove stabilator, fold blades (main and tail) C141/C17 - same as above plus: fold pylon, drop main rotor head, fairing steps and antennas 		
<hr/>			
<u>CH-47D</u>	<u>C5A</u>	<u>C141</u>	<u>C17</u>
Maximum Load Capacity	2 acft	0 acft	0 acft
<u>TIMES</u>			
Disassemble	17.5 hrs	N/A	N/A
Load	2.0 hrs	N/A	N/A
Unload	2.0 hrs	N/A	N/A
Assemble	23.0 hrs	N/A	N/A
Notes:	<ol style="list-style-type: none"> 1. Times above represent one aircraft, 6 person crew 2. Figures do not include 0.5 hrs for test flight 3. Major disassembly work: C5A - remove forward and aft blades, remove aft pylon, remove forward transmission package C141/C17 - N/A 		

Legend: See the glossary for acronyms and abbreviations.

Figure A-3. Strategic air movement planning factors



APPENDIX B

INITIAL PLANNING CONFERENCE CHECKLIST

B-1. PURPOSE

The purpose of this appendix is to provide a suggested format of an example checklist for air assault planning. This checklist should be used by the aviation battalion staff during the IPC, the first step in the development of the air assault plan. This checklist is designed to assist the aviation battalion staff in developing critical information needed by both the aviation task force and the AATF. The information gained in the IPC will be used to develop the aviation OPORD and AMB.

B-2. INITIAL PLANNING CONFERENCE CHECKLIST

Figure B-1 shows a suggested format for the IPC checklist.

<p>DTG _____</p> <p>Supported Unit _____ Aviation Unit _____</p> <p>1. Initial information required from the AATFC:</p> <p>a. Ground Unit Mission _____</p> <p>b. Enemy Situation (Get SITEMP from the AATF S2)</p> <p> 1. Location/Equipment.</p> <p> 2. Capabilities.</p> <p> 3. Probable COAs during the air assault.</p> <p>c. Friendly Situation (Get Operations overlay from the AATF S3)</p>
--

Figure B-1. Suggested format for an IPC checklist

1. Mission of next higher unit.

2. AATF Commander's Intent.

3. Location of adjacent units.

d. Air Assault Task Organization.

1. Forces available for the air assault.

2. Command relationship of available forces.

e. Concept of the Ground Operation. _____

f. Force Required to be Air Assaulted/Air Moved.

1. Total number of passengers: _____

2. Total number of Sling Loads (by type):

<u>TYPE</u>	<u>NUMBER</u>	<u>WEIGHT</u>
_____	_____	_____
_____	_____	_____
_____	_____	_____

3. Internal Cargo Requirements (Type, amount, and weight): _____

g. Proposed PZ Locations: _____

h. Proposed LZ Locations: _____

i. Fire Support Assets Available: _____

Figure B-1. Suggested format for an IPC checklist (continued)

<p>k. Attack Helicopter Missions: _____</p>
<p>_____</p>
<p>l. Air Cavalry Missions: _____</p>
<p>_____</p>
<p>m. Planned Rehearsals (DTG):</p>
<p> 1. Assault Force Operations Rehearsal: _____</p>
<p> 2. Air Assault Operations Rehearsal: _____</p>
<p> 3. Fire Support Rehearsal: _____</p>
<p> 4. PZ Rehearsal: _____</p>
<p>2. Fire Support/IEW Plan:</p>
<p> a. Supporting Artillery Unit (Type and Location): _____</p>
<p> b. Gun-Target Line for Firing Batteries: _____</p>
<p> c. Receive a copy of current target lists produced by the FSO.</p>
<p> d. EW Assets available for the mission: _____</p>
<p> e. Close Air Support:</p>
<p> 1. Unit/Type Aircraft: _____</p>

Figure B-1. Suggested format for an IPC checklist (continued)

2. Number of Missions/Sorties: _____

3. Munitions: _____

4. Final Control Procedures: _____

5. Airspace Control Measures in Effect for CAS: _____

4. Landing Plan.

a. Tentative H-Hour (if known): _____

b. Primary LZ Selection:

<u>LZ NAME</u>	<u>LZ LOCATION</u>
_____	_____
_____	_____
_____	_____

c. Alternate LZ Selection:

<u>LZ NAME</u>	<u>LZ LOCATION</u>
_____	_____
_____	_____
_____	_____

d. Total Number of Loads for each LZ: _____

Figure B-1. Suggested format for an IPC checklist (continued)

<p>e. LZ Preparatory Fires.</p> <p>1. Initiated by: _____</p> <p>2. Initiate at (Time/Loc): _____</p> <p>3. Type of Last Round: _____</p> <p>f. Attack/Air Cavalry Helicopter Supporting Fire Plan: _____</p> <hr/> <p>1. Weapons Configuration: _____</p> <p>2. Holding Area Locations: _____</p> <p>3. ABFP/BP Locations: _____</p> <hr/> <p>4. On-Station Times: _____</p> <p>5. Relief Times: _____</p> <p>6. Weapons Orientation: _____</p> <p>7. Sectors of Fire: _____</p> <p>8. Fire Control Measures (TRPs, EAs, Engagement Priorities, Target Priorities)</p> <p>9. Weapons Control Status: _____</p> <hr/> <p>g. M60D Door Gunner Weapons Control Status: _____</p> <hr/> <hr/>

Figure B-1. Suggested format for an IPC checklist (continued)

h. Laager Site Locations: _____

i. Extraction Requirements:

1. Primary PZ Selection:

<u>PZ NAME</u>	<u>PZ LOCATION</u>	<u>PZ MARKING</u>
_____	_____	_____
_____	_____	_____
_____	_____	_____

2. Alternate PZ Selection:

<u>PZ NAME</u>	<u>PZ LOCATION</u>	<u>PZ MARKING</u>
_____	_____	_____
_____	_____	_____
_____	_____	_____

3. Extraction Code Words: _____

5. Air Movement Plan.

a. Air Routes/Corridors/Axis:

1. Primary (See Overlay): _____

2. Alternate (See Overlay): _____

b. Attack/Air Cavalry Helicopter Concept: _____

1. Link-up Time and Location with Assault Assets: _____

Figure B-1. Suggested format for an IPC checklist (continued)

<p>2. Attack Routes: Primary: _____</p>								
<p style="text-align: center;">Alternate: _____</p>								
<p>3. Actions on Contact: _____</p>								
<p>c. Fire Support Plan:</p>								
<p>1. Responsibility for Calling Fires: _____</p>								
<p>2. Firing Battery Gun-Target Line, Call Sign, Frequency: _____</p>								
<p>3. Target List (on overlay if possible)</p>								
<p>d. False Insertions En route:</p>								
<table style="width: 100%; border: none;"> <thead> <tr> <th style="text-align: center; width: 50%;"><u>LZ NAME</u></th> <th style="text-align: center; width: 50%;"><u>LZ LOCATION</u></th> </tr> </thead> <tbody> <tr> <td style="text-align: center;">_____</td> <td style="text-align: center;">_____</td> </tr> <tr> <td style="text-align: center;">_____</td> <td style="text-align: center;">_____</td> </tr> <tr> <td style="text-align: center;">_____</td> <td style="text-align: center;">_____</td> </tr> </tbody> </table>	<u>LZ NAME</u>	<u>LZ LOCATION</u>	_____	_____	_____	_____	_____	_____
<u>LZ NAME</u>	<u>LZ LOCATION</u>							
_____	_____							
_____	_____							
_____	_____							
<p>e. Time warnings the flight crews will provide to the assault force: _____</p>								
<p>f. Hazards en route: _____</p>								
<p>_____</p>								
<p>_____</p>								

Figure B-1. Suggested format for an IPC checklist (continued)

g. Downed Aircraft Procedures:

1. Flight Crew
2. Passengers

h. Bump

Plan: _____

i. En route Mission Abort Criteria.

1. Loss of _____ aircraft
2. Other: _____

6. Loading Plan:

a. PZ Data:

Pick-up Zone number: _____

Pick-up Zone Name: _____

PZ Location: _____

PZ Landing Heading: _____

PZ Markings: _____

PZ Control Frequency and Procedures: _____

PZ Control Officer: _____

PZ Diagram (Attach to this a sketch of the PZ)

External Load Procedures.

b. Total passengers to be moved: _____

c. PZ Security Plan.

Figure B-1. Suggested format for an IPC checklist (continued)

d. Aircraft Loads:

1. ACL for each aircraft: _____
2. Ammo/Pyro: _____
3. Combat Load of the Passengers (Rucks?, Weapons?): _____

4. Special Equipment
Required: _____

5. Number/Type of Sling Loads: _____

6. Sling Load Procedures (Hook up Procedures, Markings, Rigging, Location in PZ): _____

e. Static Loading Required (Yes/NO)

f. Doors Open/Doors Closed?

7. Other Coordination Requirements:

- a. Follow-on Missions/Contingencies:
 1. CASEVAC (Determine pick up locations, drop off locations, call signs and frequencies of drop off sites, code words).
 2. Resupply Operations: _____

Figure B-1. Suggested format for an IPC checklist (continued)

<p>b. DART Team Procedures, Security, and Location.</p> <p>c. ALSE Requirements:</p> <p style="padding-left: 40px;">1. Water Wings (Yes/NO)</p> <p style="padding-left: 40px;">2. Life Rafts (Yes/No)</p> <p>d. MOPP Level: _____</p> <p>e. Location and Time of the Air Mission Brief: _____</p>
<p>f. Location and Time of the Aviation OPORD: _____</p>
<p>8. Command and Signal.</p> <p>a. AATFC Location during the air assault: _____</p> <p>b. Ground Force Commander Location: _____</p> <p>c. AMC Location: _____</p> <p>d. Aviation S3 Location: _____</p> <p>e. AATF CP Location for Air Assault: _____</p>
<p>f. Will Airborne CP be Used (Yes/No)</p> <p style="padding-left: 40px;">1. Pick up Time and Location: _____</p> <p style="padding-left: 40px;">2. Passengers: _____</p> <p style="padding-left: 40px;">3. COMSEC Loading Procedures: _____</p>

Figure B-1. Suggested format for an IPC checklist (continued)

4. ROZ Limits/Procedures: _____

g. Communications Procedures:

1. Establish Radio Nets for PZ Control, AATF Commandd Net, CAN, Air Battle Net, Fire Support Net.
2. Verify COMSEC fills.
3. Establish Retransmission plan if necessary.

9. Refuel Procedures: Establish refuel procedures and coordinate for land to emplace a FARP if necessary.

10. Force Protection:

a. Fratricide Avoidance Measures: _____

b. Weapons Handling: _____

c. Risk Assessment: _____

11. GPS Time Hack with Key Air Assault Personnel.

Legend: See the glossary for acronyms and abbreviations.

Figure B-1. Suggested format for an IPC checklist (concluded)



APPENDIX C

AIRCREW BRIEF

C-1. PURPOSE

The purpose of this appendix is to provide a suggested format for an AB. This briefing is to be used for air assault operations. It is in the format of an OPORD and may be used by the battalion to issue the air assault OPORD or be used by company commanders in issuing the AB.

C-2. AIRCREW BRIEF

Figure C-1 shows a suggested format for an AB.

AIRCREW BRIEF		
Roll Call _____	Time Zone Used _____	Time Hack _____
OPORD References _____		
Unless asked for, hold all questions until the end of the brief.		
Task Organization:		
	<u>TF</u> _____	<u>X-XXX</u>
	CO/	
	CO/	
	CO/	
I. SITUATION:		
a. Enemy Forces.		
	(1) IN/AR _____	

Figure C-1. Suggested format for an AB

(2) FA _____

(3) ADA _____

(4) Air support (FW/RW) _____

(5) Strength and morale. _____

b. Friendly Forces.

(1) Mission of the next higher headquarters and commander's intent

(2) Command relationships with supported ground forces _____

c. Attachments and Detachments and Effective Dates and Times _____

(1) Missions _____

(2) Command relationships _____

d. ADA _____

(1) IFF procedures and times _____ / _____

e. Weather and NOTAMS.

Ceiling _____ Vis _____ Wind _____ Max temp _____ Max PA _____

Max DA _____ EENT _____ BMNT _____ Dew Point _____ Spread _____

SR _____ SS _____ MR _____ MS _____ % Illum _____

Weather warning/advisories _____

*Weather decision time/location _____ WX abort criteria _____

Figure C-1. Suggested format for an AB (continued)

NOTAMS _____

II. MISSION: (Who, What, When, Where, Why) _____

III. EXECUTION: GENERAL OVERVIEW-(details briefed at subunit).

a. Concept of the Operation and Commanders Intent _____

b. Maneuver (Air Movement Table).

(1) Refer to page 4 (3a. Load Plan), for crew chief's attending brief.
 At aircraft time _____

(2) Number of aircraft by type and unit _____

(3) Air routes/corridors and mission profiles. (details briefed at subunit)

(4) Objectives/H-hour _____

(5) Time or event driven _____

(6) Phasing _____

c. Fires:

(1) FA unit and mission (DS/GS/R/GSR) _____ / _____

Priority of fires 1. _____ 2. _____ 3. _____

Figure C-1. Suggested format for an AB (continued)

Chemical _____

Illumination (planned or on call) _____

(2) CAS _____

ATK Support (Detailed at subunit) _____

Battle positions (Detailed at subunit) _____

(3) Naval Gun Fire _____

(4) ROZ (C², CASEVAC) _____

d. Deception Plan (Detailed at subunit).

(1) Air route _____

(2) False insertion _____

(3) Code words _____

****QUESTIONS****

e. Subunit Instructions. (Detailed briefing) Briefed by Flt Lead

(1) Crews, duties, frequencies, call signs (Refer to Crew Cards)

(2) Commo/line up/takeoff times _____ / _____ / _____

(3) Fuel required (in hrs and min) _____ / _____

Figure C-1. Suggested format for an AB (continued)

f. Staging plan.

(1) Route from FOB to PZ.

Dept type (S/S - Flt) _____

Name _____ Formation _____ En route G/S - A/S _____

Rotor Sep _____ Angle _____ Altitude _____

SP _____ ACPs _____ RP _____

(2) PZ name and Location. _____

Landing Form/Direction _____ / _____

Markings/Control _____ / _____

PZ landing Time _____ PZ Hazards _____

Go arounds Flt _____ Single Ship _____

Estimated time in the PZ _____

ATK msn from FOB to PZ _____

(3) Actions while in the PZ.

(a) Loading plan

ACL (combat troops) _____ Aircraft config _____

Troop load procedures _____ Cargo doors _____

Internal cargo _____ Special equip _____

External cargo _____

Figure C-1. Suggested format for an AB (continued)

Bad load criteria _____

Bump plan _____

g. Air Movement Plan.

Crank Proced APU _____ Eng _____ Up call _____

Dept time and heading _____ / _____

Dept type(SS/Flt) _____

(1) Route from PZ to LZ.

Name _____ /ALT _____ Formation _____

En route G/S _____ Rotor Sep _____ Angle _____

Altitude _____ SP _____

ACPs _____ / _____ / _____ RP _____

En route hazards Pri _____ Alt _____

Penetration points Pri _____ Alt _____

SEAD plan (if required)
Pri _____ Alt _____

False Insertion pts (if required)
Pri _____ Alt _____

(2) LZ name and location Pri _____ Alt _____

Landing direction and formation
Pri _____ Alt _____

Figure C-1. Suggested format for an AB (continued)

Markings and control Pri _____ Alt _____
 LZ landing time Pri _____ Alt _____
 Go around (flight/single ship)
 Pri _____ Alt _____
 LZ hazards Pri _____ Alt _____
 LZ fire support/control Pri _____ Alt _____
 Troop exit procedures Pri _____ Alt _____
 External load procedures Pri _____ Alt _____
 ADA status Pri _____ Alt _____
 Weapons status Pri _____ Alt _____
 ATK msn from PZ thru LZ Pri _____
 Alt _____
 Battle positions (name and location)
 1 - Pri _____ Alt _____
 2 - Pri _____ Alt _____
 3 - Pri _____ Alt _____
(3) Route from LZ, to PZ.
 Departure type (single ship/as flight) _____
 Name _____ Formation _____
 En route G/S - A/S _____ Rotor Sep _____
 Angle _____ Altitude _____
 SP _____ ACPs _____ RP _____

Figure C-1. Suggested format for an AB (continued)

En route hazards _____

Penetration points _____

(4) PZ name and location _____

Landing direction and formation _____ Land time _____

Markings and control _____ PZ hazards _____

Go around (single ship/flight) _____

(5) Actions while in the PZ

(a) Loading plan

ACL (combat troops) _____ aircraft config _____

Troop load procedures _____ Cargo doors _____

Internal cargo _____ Special equip _____

External cargo _____

Bad load criteria _____

Bump plan _____

h. Coordinating Instructions.

(1) Aircraft preparation

(a) Cargo hook/rappel rings/FRIES bar required _____

(b) Belts extended/headsets for passenger _____

(c) Identaplate/credit card required _____

Figure C-1. Suggested format for an AB (continued)

- (2) Special equipment required _____
- * (3) Door gun status RED _____ AMBER _____ GREEN _____
- (4) ADA status FREE _____ TIGHT _____ HOLD _____
- (5) ADA warnings WHITE _____ YELLOW _____ RED _____
- (6) MOPP level/NBC warning status _____ / _____
- (7) IFF procedures/times Code A _____ Code B _____
- (8) Chaff and ALQ-144 employment _____
- (9) Mission contingencies _____
- (a) Spare aircraft procedures _____
- *(b) Abort criteria (aircraft) _____
- (c) Threat breakup procedures _____
- *(d) Lead change/formation exit procedure _____
- *(e) Lost contact/in-flight join up procedures _____
- (f) Downed ACFT procedures _____
- (g) DARP/SAR plan _____
- (h) SERE plan _____
- (10) Light signals _____
- (11) External lighting _____
- (12) Lost comms (day/night) _____ / _____

Figure C-1. Suggested format for an AB (continued)

***(13) NVG specific Procedures**

(a) NVG failure procedures _____

(b) Spare NVGs and batteries _____

(14) IIMC Base Alt _____ Dir of turn/number of degs _____ / _____

Afld _____ Freq _____

(15) PPC (on your own) special considerations _____

***(16) Mission brief sheet completed and signed? _____**

***(17) Risk assessment completed/signed? _____**

***(18) Safety considerations/Hazards _____**

(19) OPSEC/COMSEC considerations
(SOI/kneeboard/sheets/overlays/maps)

(20) Debrief location and time _____ / _____

****QUESTIONS****

NOTE: Items annotated with an asterisk (*) are mandatory briefing items.

IV. Service Support.

a. **Class I** - (MREs/water aboard) _____ / _____

b. **Class III** (as required)

(1) FARP location/markings/diagram _____

(2) Freq./call sign _____ / _____

(3) FARP procedures/fuel quantity _____

Figure C-1. Suggested format for an AB (continued)

(4) Alternate refuel/airfield sites _____

c. **Class V** _____

d. **Class VIII (Medical)** _____

V. COMMAND AND SIGNAL

a. Command.

(1) AATF commander's location _____

(2) Avn TF AMC/location _____ / _____

(3) Internal chain of command _____

b. Signal.

(1) Additional call signs and frequencies

<u>UNIT</u>	<u>FREQ</u>	<u>C/S</u>	<u>UNIT</u>	<u>FREQ</u>	<u>C/S</u>
_____	_____	_____	_____	_____	_____
_____	_____	_____	_____	_____	_____
_____	_____	_____	_____	_____	_____
_____	_____	_____	_____	_____	_____

(2) Code Words

“BINGO” = LOW FUEL _____ lbs _____ / _____

_____ = Flight ready/up _____ / _____

_____ = Lost/disoriented _____ / _____

_____ = Lead change _____ / _____

Figure C-1. Suggested format for an AB (continued)

(3) Challenge/password. _____ / _____

(4) SOI/secure fill positions _____ / _____

**MISSION BRIEF BACK / FINAL QUESTIONS-
IP / ASO COMMENTS -
COMMANDER'S COMMENTS-**

Enclosure - 1

g. **Air Movement Plan - _____ to _____**

Crank Proced (if required) APU _____ Eng _____ Up call _____

Dept type (Single ship/as flight) _____ Dept head _____ Dept time _____

() **Route from _____ to _____**

Name _____ /ALT _____ Formation _____ En route G/S _____

Rotor Sep _____ Angle _____ Altitude _____

SP _____ ACPs _____ RP _____

En route hazards Pri _____ Alt _____

Penetration points Pri _____ Alt _____

SEAD plan (if required) Pri _____ Alt _____

False Insertion pts (if required) Pri _____ Alt _____

() **Name and Location** Pri _____ Alt _____

Landing formation and direction Pri _____ Alt _____

Markings and control Pri _____ Alt _____

Figure C-1. Suggested format for an AB (continued)

Landing time	Pri _____	Alt _____
Go around (flight single ship)	Pri _____	Alt _____
Hazards	Pri _____	Alt _____
FARP procedure	Pri _____	Alt _____
Fire support/control	Pri _____	Alt _____
Troop entry/exit procedures	Pri _____	Alt _____
External load procedures	Pri _____	Alt _____
ADA status	Pri _____	Alt _____
Weapons status	Pri _____	Alt _____
() ATK msn	Pri _____	Alt _____
Battle positions (name and location)	Pri _____	Alt _____

Legend: See the glossary for acronyms and abbreviations.

Figure C-1. Suggested format for an AB (concluded)



APPENDIX D

LIAISON OFFICER CHECKLIST AND BRIEF

D-1. PURPOSE

The purpose of this appendix is to provide suggested formats for two checklists. The first checklist (Figure D-1) is for the LNO. It contains a list of required equipment for effective LNO operations, as well as a list of information needed and actions to take at both the parent headquarters and the supported unit. Figure D-2 is a suggested format for the LNO briefing. This checklist is in a briefing format. This briefing contains essential information the LNO should provide to the supported unit commander or POC as soon as possible after arriving at the supported unit. This will most likely not be a formal type briefing. However, the LNO should seek out the supported unit commander or POC immediately upon arrival and provide them the critical information contained in this checklist.

D-2. LIAISON OFFICER CHECKLIST

Figure D-1 presents a suggested format for the LNO checklist to assist the LNO in preparing for this duty.

- 1. Required Equipment. This equipment list is the minimum essential equipment for an LNO to sustain operations and provide essential support:**
- a. Must have mobility matching the supported unit's vehicles.
 - b. Camouflage to cover vehicle.
 - c. Secure communications equipment capable of reaching parent unit from supported unit. Must include remote operation capability and spare batteries.
 - d. Tentage.
 - e. Mapboard of the AO.

Figure D-1. Suggested format for an LNO checklist

- f. GPS.
 - g. NODs.
 - h. Paper, acetate, alcohol, shop towels, pens, paper, alcohol markers, and tape.
 - i. Class I.
 - j. A current SOI.
 - k. Reference materials (type of reference material will vary depending on the mission).
 - l. Signaling devices (strobe lights, IR chem lites, bean bag lights).
 - m. RTO.
2. LNO Checklist.
- a. Actions prior to departure to supported unit.
 - 1. Location of supported unit.
 - 2. POC (by name if possible).
 - 3. Frequency and call sign of supported unit.
 - 4. Challenge and password of supported unit.
 - 5. Current unit status.
 - Aircraft status.
 - Personnel status/crew cycles.
 - Communications.
 - Security equipment.

Figure D-1. Suggested format for an LNO checklist (continued)

6. Locations.

- Bn TOC (current and future).
- Subordinate units.
- FARP (current and future).

7. Intelligence Update.

- Enemy situation.
- Known locations.
- Probable COAs.
- Weather outlook for the anticipated mission times.

8. Mission.

- Special equipment requirements.
- Understanding of the mission and commander's intent.
- Copy of graphics and OPORD.
- REDCON status.

9. General Information.

- Friendly ADA locations.
- Friendly ground units in the AO (call signs and frequencies).
- Decon sites.
- Medical support in the AO.
- Decision points to launch the mission.
- Boundaries and required coordination.
- CAS availability (call sign and frequency).

Figure D-1. Suggested format for an LNO checklist (continued)

b. Actions at Supported Unit.

1. Determine the ground commander's intent for aviation use and mission.
2. Determine locations of TOCs and TACs (for brigade and task force units).
3. Determine the front line trace of friendly units.
4. Find out the location of all artillery PAs for all firing batteries.
5. Determine the locations of all friendly ADA assets operating in the AO.
6. Brief POC on the capabilities of the aviation assets supporting him.
7. Determine the ground tactical plan (ground scheme of maneuver).
8. Coordinate passage of lines.
9. Determine supported units communications plan.
10. Coordinate fires as required (obtain target lists from the FSO and assist in developing fire support plans for aviation missions).
11. Coordinate airspace for the aircrews operating in the AO.
12. Determine H-hour.
13. Coordinate for EW support for missions.
14. Determine locations of medical support facilities in the AO.

Legend: See the glossary for acronyms and abbreviations.

Figure D-1. Suggested format for an LNO checklist (concluded)

D-3. LIAISON OFFICER BRIEF

Figure D-2 presents a suggested format for an LNO brief. This will assist the LNO in preparing for the briefing to the supported unit.

A. INTRODUCTION.

1. Classification of the briefing.
2. Purpose of the briefing.
3. What unit the LNO is from.

B. INTELLIGENCE.

1. Enemy actions in and around the supporting aviation unit's AA (past 24 to 48 hours).
2. Expected enemy contact in the aviation unit's area of operations.
3. Aviation constraints that may effect the mission (weather).

C. OPERATIONS.

1. Current location of the supporting aviation unit(s).
2. Location of supporting aviation unit(s) in the next 24 to 48 hours.
3. Attachments to the aviation unit.
4. Detachments from the aviation unit.
5. Committed aircraft not available for support (division or brigade commanders aircraft, Fat Cow configured aircraft, etc.).
6. Number and type of aircraft available to support the mission.
7. Planning ACL per aircraft.
8. Number of day and night crews available for the mission.

Figure D-2. Suggested format for an LNO brief

D. LOGISTICS.

1. Current aircraft status.
2. Current weapons system status (M-60D, attack helicopters, if attached).
3. Expected aircraft status in the next 24 to 48 hours.
4. Expected major weapons system status in the next 24 to 48 hours.
5. Current fuel and ammo status.

E. COMMAND AND SIGNAL.

1. Call sign and frequency of supporting aviation unit and LNO.
2. Current chain of command.
3. Number of C² aircraft available for the mission.
4. Planned location of the aviation LNO - before, during, and after the operation.
5. Procedural and positive control measure(s) that exist in the supported units area of operation (A²C²).

F. CROSS COORDINATION (things the LNO should get from the supported unit).

1. Planning time line.
2. Mission (two levels up).
3. Command relationships.
4. Initial planning graphics.
5. Call sign and frequencies.
6. Time hack.

G. SUMMARY. Once this information has been received, the LNO should return to the parent aviation unit and continue to go between the supported unit and parent unit as necessary to coordinate mission details and conduct mission coordination.

Legend: See the glossary for acronyms and abbreviations.

Figure D-2. Suggested format for an LNO brief (concluded)



APPENDIX E

FORWARD ARMING AND REFUELING POINT OPERATIONS

E-1. PURPOSE

The purpose of this appendix is to discuss the use of UH-60s and CH-47s to conduct refueling operations (Fat Hawk/Fat Cow). This appendix is devoted solely to air-transportable FARPs. [FM 1-111](#) provides complete details on FARP operations. [FM 1-111](#) is a vital part of any flight operations, or LNO, library and remains the primary reference for FARP operations. [FM 1-111](#) should be readily available to utility and cargo helicopter operations personnel, especially when deployed or displaced from their unit.

E-2. FORWARD ARMING AND REFUELING POINT PRINCIPLES Principles.

a. The FARP is vital to the success of the aviation combat mission. Attack, air assault, and support aviation units depend on the FARP to provide fuel and ammunition where and when they are needed. A FARP is a temporary arming and refueling facility that is organized, equipped, and deployed by an aviation unit commander to support tactical operations. It is usually located closer to the AOs than the CSS area of an aviation unit. The FARP provides fuel and ammunition for aviation units in combat. The fluid situation of the battlefield demands that it be austere, transitory, and able to support specific mission objectives. It should be flexible enough to self-deploy or to be aurally inserted, and it must meet the class III/V needs of mission aircraft. The FARP increases the time on station for the commander by reducing the turnaround time associated with refueling and rearming. It is operated and organized according to the factors of METT-T.

b. There are three basic principles that must be satisfied when planning a FARP to support aviation units. They are as follows:

- (1) The FARP must meet unit mission requirements.
- (2) The FARP must provide support throughout the battlefield under all conditions.
- (3) The FARP must avoid threat observation and engagement.

E-3. ADVANTAGES AND DISADVANTAGES

The utility or cargo helicopter's ability to move combat assets quickly throughout the battlefield makes it a unique and valuable resource to the maneuver commander. However, there are advantages and disadvantages to using UH-60s and CH-47s for refueling.

a. *Advantages.*

- Easy for the supported unit.
- Lower flight altitude.
- Extended range due to ERFS.
- Can reposition rapidly.
- Can be inserted into areas inaccessible to ground vehicles (rough terrain, cross-FLOT).

b. *Disadvantages.*

- Noncrashworthy fuel systems (ERFS).
- No ballistic protection (ERFS).
- Reduced single engine capability for the UH-60 and CH-47.
- Limited ability to refuel large numbers of aircraft (UH-60).
- Aircraft must shut down to the APU (UH-60).
- Limited FARP security (especially cross-FLOT).

E-4. CH-47D FORWARD ARMING AND REFUELING POINTS (FAT COW).

a. The CH-47D is the primary aircraft used for air transporting FARPs. The CH-47D has the capability to transport, and to pump, up to 2,320 gallons of aviation fuel. This fuel is contained in 600-gallon, noncrashworthy tanks. Each 600-gallon tank has only 580 gallons usable, hence the 2,320 gallons (4 x 580) available total. The respective totals are 580, 1,160, 1,740, or 2,320 gallons, depending on the number of tanks carried by any one CH-47D aircraft.

Each CH-47D is a complete package by itself, with no additional aircraft required to make the FARP functional.

b. The CH-47D may also be equipped to refuel itself by employing the ERFS equipment, which would feed from those tanks carried internally. See Figure E-1

for the CH-47D FARP layout.

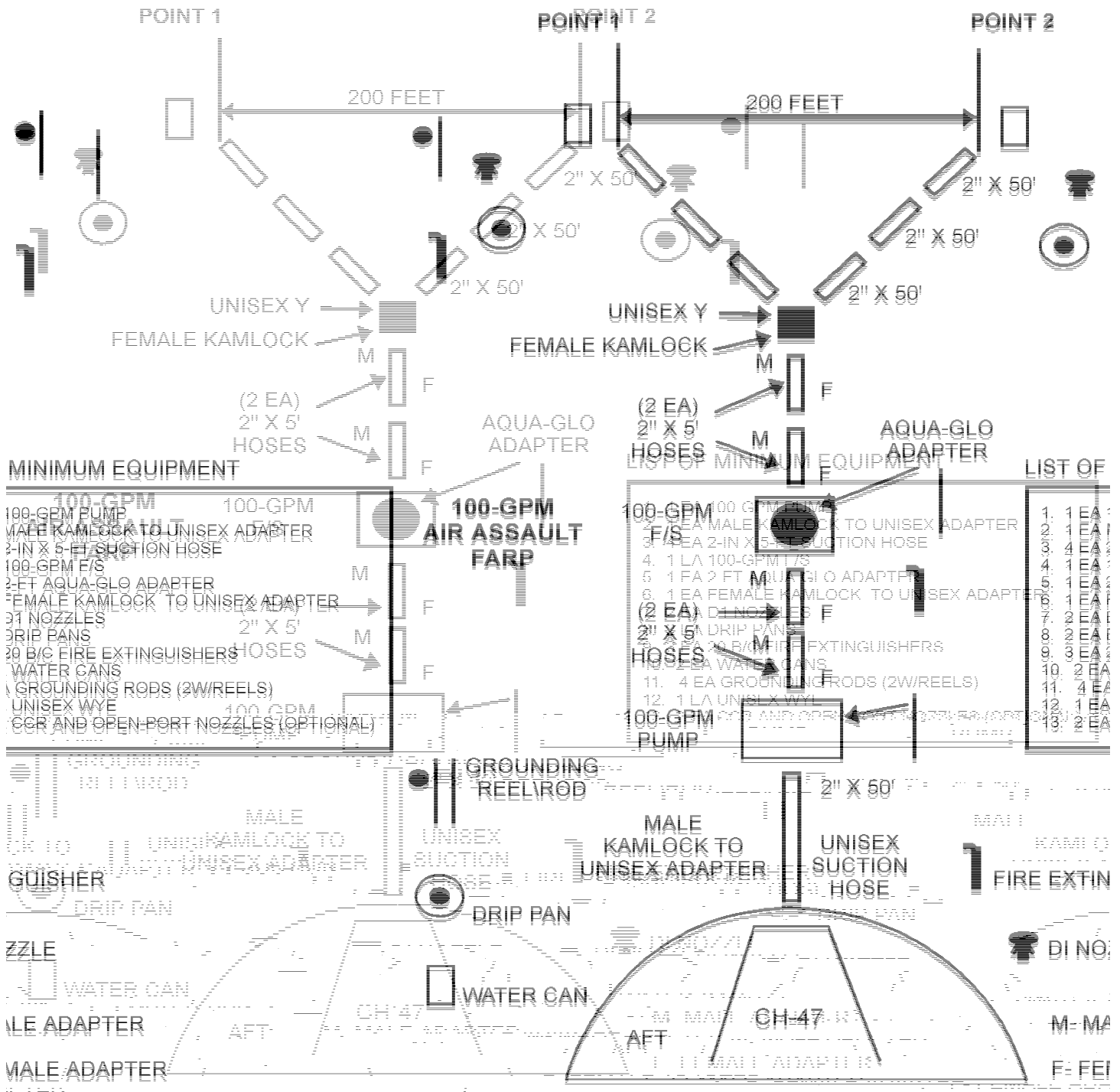

Legend: See the glossary for acronyms and abbreviations.

Figure E-1. CH-47 FARP site

E-5. UH-60 FORWARD ARMING AND REFUELING POINTS (FAT HAWK)

a. The UH-60 has become a viable tool in FARP operations with the employment of the Fat Hawk system. Fat Hawk refers to a UH-60 configured for refueling and rearming. The Fat Hawk consist of a UH-60 with the ERFS, a micro-fare system to pump fuel, two fuel handlers, and ammunition. The type of ammunition carried by the aircraft will be METT-T dependent, but will most probably consist of Hellfire missiles, 2.75-inch rockets, .50 caliber, or a combination of the above. The ERFS

allows the UH-60 to carry either 230-gallon or 450-gallon external fuel tanks, so the amount of fuel available for the refueling operation is dependent on the aircraft configuration. Additionally, aircraft configuration will affect the amount of ammunition that the UH-60 can carry (based upon weight).

b. The system operates from the micro-fare system carried aboard the aircraft. Once set at the refueling point, the fuel handlers will set up the pumps and hoses and prepare for refueling operations. On the UH-60, refueling occurs by pumping fuel out of the main fuel tanks, which are replenished by fuel transfer from the external tanks. A disadvantage of the Fat Hawk is that fuel transfer occurs at a slower rate than fuel pumping. This results in two things--the aircraft must shut down to idle for refueling operations, and delays may occur between aircraft refueling to allow the UH-60 to replenish the main fuel tanks. A properly configured aircraft and a well-planned mission will result in the ability for two UH-60s with ERFS to refuel and rearm a platoon of OH-58D (I) aircraft in 15 minutes.

c. *Aircraft Preparations.*

- (1)** Excess seats are removed to make room for the FARE equipment and ammunition.
- (2)** Personnel requirements consist of two crew chiefs per aircraft, three fuel handlers (single point refueling) or four fuel handlers (dual point refueling), three rearming personnel, combat lifesaver or medic, and security personnel (as required based on METT-T).
- (3)** Aircraft load configuration is based on METT-T.
- (4)** A minimum of two aircraft should be used for the most efficient and rapid operation.
- (5)** See Figure E-2 for the single and dual point UH-60 FARPs.

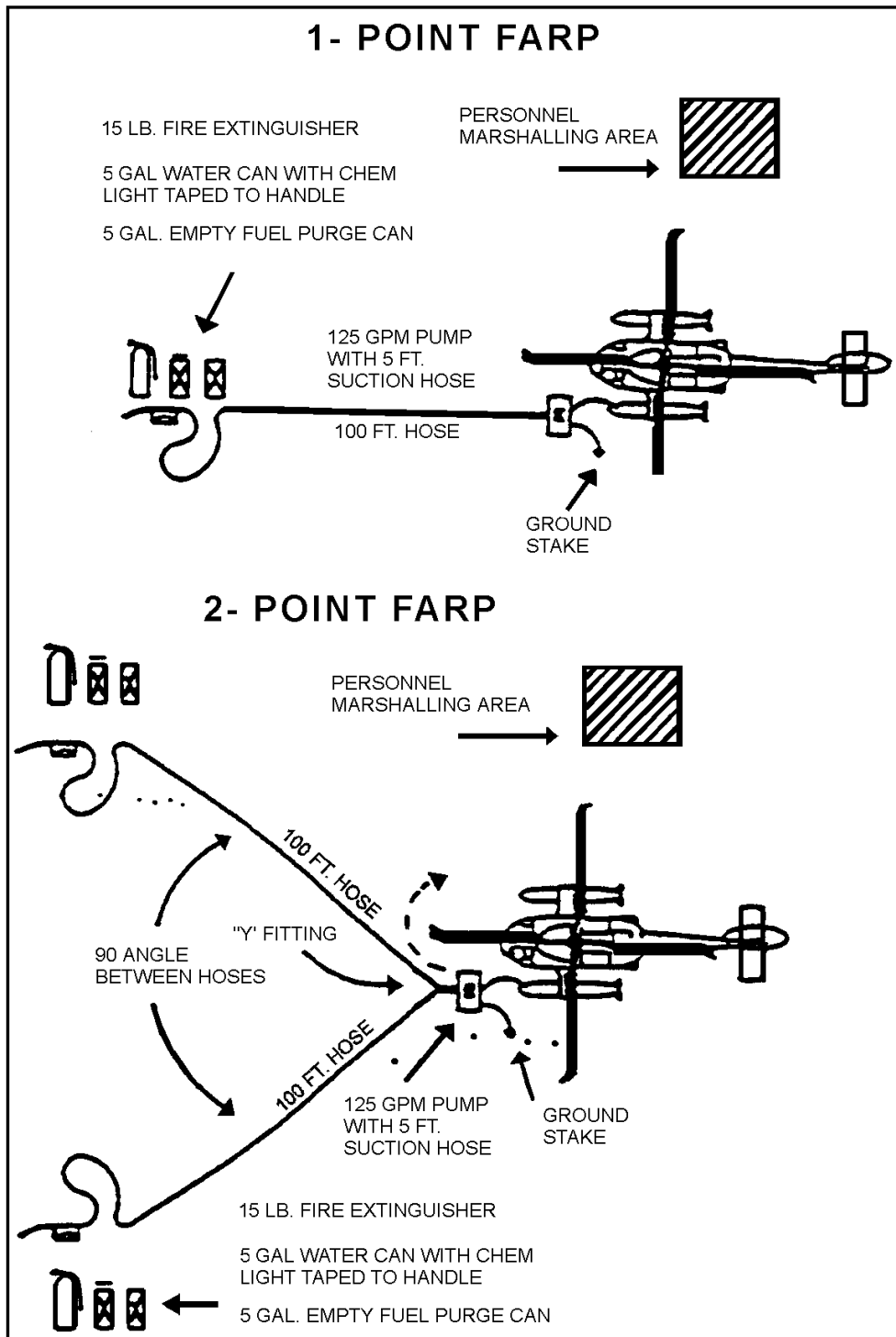

Legend: See the glossary for acronyms and abbreviations.

Figure E-2. UH-60 FARP site



APPENDIX F

RISK MANAGEMENT/RISK ASSESSMENT

Tough, realistic training conducted to standard is the cornerstone of Army warfighting skills. An intense training environment stresses both soldiers and equipment, creating a high potential for accidents. The potential for accidents increases as training realism increases, just as it does in combat. The end result is the same, the soldier or asset is lost. Commanders must find ways to protect individuals, crews, teams, and equipment from accidents during training and combat. How well they do this could be the decisive factor in winning or losing. Risk management is a commonsense tool that leaders can use to make smart risk decisions in tactical and everyday operations. It is a method of getting the job done by identifying the areas that present the highest risk and taking action to eliminate, reduce, or control the risk. It is not complex, technical, or difficult. It is a comparatively simple decision making process, a way of thinking through a mission to balance mission demands against risks.

F-1. COMMAND RESPONSIBILITIES

The commanders are responsible for effectively managing risk. They must--

- Willingly determine the proper balance that will achieve optimum performance from their command.
- Select the best risk-reduction options from those that the staff provides.
- Accept or reject residual risk, based on perceived benefits.
- Recommend appropriate control measures.
- Train and motivate leaders at all levels to effectively use risk management concepts.
- Ensure that risk controls are integrated into plans and orders.
- Ensure that unnecessary safety restrictions are eliminated to maximize training and combat effectiveness.
- Maintain a total commitment to mission accomplishment and the welfare of subordinates.

- Use the risk management process to identify, assess, and control hazards for their mission.
- Report risks beyond their control or authority to their superiors for resolution.

F-2. INDIVIDUAL RESPONSIBILITIES

Each individual soldier must--

- Understand, accept, and implement risk reduction guidance and the concept of risk management and assessment.
- Maintain a constant awareness of the changing risks associated with the operation.
- Make leaders immediately aware of any unrealistic risk reduction procedure
- Report risks beyond their control or authority to their superiors for resolution.

F-3. FIVE-STEP RISK MANAGEMENT PROCESS

a. Step 1. Identify Hazards. Identify the major events that are expected to occur during the operation and the hazards associated with all specified and implied tasks. The staff reviews and expands, as appropriate, the list of hazards and major events during the training or combat scenario. This procedure helps to ensure that all significant hazards have been identified, and the staff can determine the appropriate force protection measures.

b. Step 2. Assess Hazards.

(1) Hazards are assessed based on their probability of occurrence and severity of effect. Based on this assessment, the staff can--

- Determine the level of risk associated with a given hazard.
- Decide where and when control measures are appropriate to protect the force.

(2) Risk assessment matrices provide a simple analysis method of subdividing an operation into its major operational events to discover areas where the staff might eliminate or reduce risk. Each unit should develop its own risk assessment matrix with applicable major operational events similar to the one shown in [TC 1-210](#). Units can use the risk assessment matrix alone or with other analysis techniques. The matrix is nearly always more effective than intuitive methods in identifying the extent of risk. When using a risk-assessment matrix, the risk assessor must--

- Review each situation to ensure he has evaluated all significant areas of concern, even if the matrix does not include them.
- Use the matrix to analyze risk and target areas of concern for risk reducing techniques.

- Review individual areas of concern before recommending options.

(3) Another technique the risk assessor can use is the METT-T risk assessment procedure. Leaders can subjectively decide the likelihood and extent of accidental loss based on this type of analysis. When using the METT-T format, the risk assessor must--

- Determine the mission's complexity and difficulty.
- Assess the enemy situation and identify specific hazards.
- Consider all aspects of the terrain as well as weather and ability.
- Determine the supervision required and evaluate the experience, training, morale, and endurance of units and their equipment.
- Determine the time available for planning and executing the mission.

c. Step 3. Develop Controls. Control measures are developed that reduce the risk to the mission. The staff must--

- Identify hazards and assess risk.
- Focus on critical events first.
- Eliminate unnecessary risks.
- Reduce the amount of mission-essential and prudent risks by applying controls.
- Develop control options that synchronize the operation that eliminate or reduce risks.
- Recommend options for the commander's decision. Check for residual effects before suggesting options. Visualize what will happen once the option has been implemented.. Sometimes reducing one risk will only introduce other risks.
- Leaders can detect and eliminate unnecessary safety restrictions that impede the realism or effectiveness of training. With proper controls, these restrictions can be eliminated or reduced. Sensible consideration and consultation with the unit's most experienced personnel is the key here.

d. Step 4. Implement Controls. Decide, implement controls, and integrate specific controls into plans, OPORDs, SOPs, and rehearsals. Knowledge of controls, from the commander to the individual soldier, is essential for successfully implementing and executing controls.

e. Step 5. Supervise.

(1) The commander must enforce controls. Leaders monitor, follow-up, verify, and correct or modify, as appropriate, controls that the commander imposes on his subordinates. When monitoring operational activities, leaders must--

- Avoid administrative intrusions on their subordinates time.
- Go where the risks are and spend time at the heart of the action.
- Analyze and think through issues, not just observe.
- Work with key personnel to improve operational procedures after the action. Leaders must not hesitate to assess imminent danger issues on the spot.
- Fix systemic problems that are hindering combat effectiveness.
- Retain and disseminate lessons learned from mishaps, near misses, etc., to affect present and future operations.

(2) Leaders must also balance the cost of risks with the value of the desired outcome. They must consider and manage risks in making such decisions using three general rules--

- Never accept an unnecessary risk. The leader who has the authority to accept or reject a risk is responsible for protecting his soldiers from unnecessary risks. If he can eliminate or reduce a risk and still accomplish the mission, the risk is unnecessary.
- Make risk decisions at the appropriate level. The leader who must answer for an accident is the person who should make the decision to accept or reject the risk. In most cases, he will be a senior officer, but small-unit commanders and first-line leaders might also have to make risk decisions during combat. Therefore, they should learn to make risk decisions during training.
- Ensure that the benefits of a prudent risk outweigh the possible cost of the risk. Leaders must understand the possible risk and have a clear picture of the benefits to be gained from taking that risk.



APPENDIX G

AIRCRAFT SURVIVABILITY

Utility and cargo helicopters operate throughout the entire battlefield during the conduct of their assigned missions. The purpose of this appendix is to discuss aircraft survivability.

G-1. FUNDAMENTALS OF AIRCRAFT SURVIVABILITY

Aircraft survivability encompasses a vast array of disciplines. There is a tendency to think of ASE as the complete picture of aircraft survivability. ASE is only a portion of EW that is one portion of EW supporting information operations and information warfare. The Joint Chief of Staff MOP-6 changed the Army's EW terminology to reflect the unity of these functions. The three functions of EW are described below.

a. *Electronic Attack (formerly Electronic Countermeasures)*. EA is the division of EW involving the use of electromagnetic or directed energy to attack personnel, facilities, and equipment for the purpose of degrading, neutralizing, or destroying enemy combat capability. EA includes actions taken to prevent, or reduce, the enemy's effective use of the electromagnetic spectrum through jamming, destruction, and electromagnetic deception. EA also includes the employment of weapons using either electromagnetic or directed energy as the primary destructive mechanism. These weapons might include lasers, radio frequency, or particle beams. Finally, EA includes using sources of electromagnetic energy as the primary means of terminal weapons guidance to damage or destroy personnel, facilities, or equipment. ASE employed to defeat the EA systems include chaff, flares, radar jamming, and IR jamming.

b. *Electronic Protection (formerly Electronic Counter-Countermeasures)*. EP is the part of EW involving actions taken to protect personnel, facilities, and equipment from effects of friendly or enemy EW actions that may degrade, neutralize, or destroy friendly combat capability. To minimize their vulnerability to EA, EP should be considered for all battlefield systems deriving operational capabilities through the use of the electromagnetic spectrum. Included are optical, electronic, infrared, and radar target acquisition, noncooperative target recognition systems, and smart weapons systems' sensors, fuses, guidance, and control components. ASE employed systems include antenna design, signature reduction, infrared absorbing paint, etc.

c. *Electronic Support (formerly Electronic Support Measures)*. ES is the division of EW involving actions tasked by, or under the direct control of, an operational commander. The ES's responsibilities are search for, intercept, identify, and locate sources of radiated electromagnetic energy for immediate threat recognition in support of EW operations and other tactical actions, such as threat avoidance, homing, and targeting. ES focuses on surveillance of the electromagnetic spectrum in support of the commander's immediate decision making requirements for the employment of EW or other tactical actions, such as threat avoidance, targeting, or homing. ES is normally provided by organic intelligence and sensing devices based on EW technology integrated into other weapon systems, or assets from other echelons capable of providing combat information to the supported command. The purpose of ES is to ensure EA and EP applications receive the input needed to operate effectively. (Examples of ES include, battlefield systems that execute direction finding operations, detecting and identifying enemy missions, or other electromagnetically-measured signatures that enable immediate exploitation, locating high value targets for electronic attack, or providing threat avoidance information.) ASE systems include radar, laser, and infrared missile detecting sets.

d. Aircraft Survivability Equipment Philosophy. The role of ASE is to reduce the vulnerability of our aircraft, thus allowing aircrews to accomplish their immediate mission and to survive. The methodology for achieving survivability is supported by the ASE philosophy, a five-step approach to ensure that Army aircrews are able to accomplish their mission again and again. These five steps include the following, in order of least cost and most effective to the most cost and least effective:

(1) Step 1. Tactics (electronic protection). Proper tactics reduce exposure times to enemy weapons. NOE flight limits LOS exposure times and places the aircraft's radar, infrared, and optical signature in a cluttered environment. NOE tactics, combined with ASE protection, allow Army aviation to survive and perform its mission. ASE protection is severely degraded when the aircraft is not flown tactically sound (blue sky background).

(2) Step 2. Signature reduction (electronic protection). These measures are implemented through engineering or design changes, such as flat canopies, exhaust suppressers, and coating the aircraft with low-infrared reflective paint. Signature reduction alone greatly increases survivability. Without signature reduction, ASE effectiveness is degraded and, in some cases, erased. Signature control is also influenced by the aviator choosing how much signature to expose to the threat.

(3) Step 3. Warning (electronic support). The next step, in the ASE philosophy, is to provide warning to aircrews when they are about to be engaged, allowing time to react. Examples include radar, laser detecting sets, and infrared missile warning systems.

(4) Step 4. Jamming and decoying (electronic attack). When aircrews must stay on station despite warnings, there is a requirement for countermeasures capable of jamming, and/or decoying the fire control or guidance systems of threat weapons. Chaff, flares, and radar and IR jammers provide this type of protection.

(5) Step 5. Aircraft hardening (vulnerability reduction). This step provides for ballistic tolerance, redundant critical flight systems, and crashworthy features, to assist in minimizing the damage to an aircraft after it has been hit.

G-2. THREAT CONSIDERATIONS

This section is not designed to be system specific in nature, rather to provide a general knowledge of threat systems, which can be applied to specific threats on a case by case basis.

a. Threat Engagement Sequence. All weapon systems must complete a series of events, called an engagement sequence, to actually have an effect on the target (aircraft). Missing any step in the engagement sequence forces the threat engagement sequence to be started over again. Weapon systems sensors must--

- Detect.
- Acquire.
- Track.
- Launch and guide (or fire and ballistics).
- Assess damage.

b. Example Threat System. Five elements required to a compute an AAA fire control solution are *range, azimuth, elevation, velocity, and time of flight*. If one of the fire elements is incorrect, the AAA system will not hit the target.

c. Target Acquisition. The threat must detect, acquire, track (establish fire control solution), and fire at the aircraft. The time of flight of the projectile must be determined. The threat must predict where the aircraft target will be (within a few meters) as the ordinance travels to a point in space and time.

d. Threat Avoidance. Tactics, signature reduction, warning, jamming and decoys are the tools available to preclude a successful threat engagement. If hit, you may have to rely on aircraft

hardening.

e. Detection, Acquisition, and Tracking. The difference between detection and acquisition, versus tracking is very important. In detection and acquisition, the threat weapon system does not have enough refined data to facilitate firing at the aircraft. The threat weapon system must track the aircraft long enough to acquire range, azimuth, elevation, and velocity, to determine the time and position of firing. Indications of search or acquisition activity may provide the aircrew time to initiate a response. Tracking indications alert the aircrew to an immediate action requirement, such as masking, employing ASE decoys, or executing evasive maneuvers.

f. Engagement Envelope. All threat systems are confined by physics. Each threat system has a minimum and maximum effective altitude and range. These numbers are computed against a cooperative engagement (nonmaneuvering aircraft, blue sky background, flat terrain, steady velocity, etc.). The effective envelope for a threat system is based upon a 50 percentile. That is, at the maximum (or minimum) effective range (or altitude), the weapon system is able to hit the target one out of two times. As the target progresses further into the threat envelope, the probability of a first shot kill increases. As the target progresses further outside the threat envelope, the probability of being hit decreases, until the target has reached a point where it is impossible to be hit.

g. Decreasing the Probability of Hit. The aircrew has the ability to make the engagement more difficult for the threat. A stationary target allows the threat to adjust each shot from the previous shot, until it hits the aircraft. A moving, constant velocity target provides a more difficult engagement procedure. A prediction can be made from the previous shot and adjustments imposed to enhance accuracy. The most difficult engagement is the moving target that varies range, altitude, elevation, and velocity. This makes prediction nearly impossible, since four factors are changing at differing rates.

h. Threat Weapon Sensors. There are generally four major types of threat weapon sensors. These may be man-portable or transported by land, sea, or aerial platforms. It is important to determine the actual sensor type, and guidance package, for each threat and understand their inherent capabilities and limitations. (For in-depth information concerning particular threat systems, contact your unit electronic warfare officer or tactical operations officer.) The four major types of threat weapon sensors are radar, IR, laser and DEW, and optical/EO.

(1) Radar. Direct threat radar weapons require LOS to hit the target. Direct threat radar weapons are either fire controlled AAA or for missile systems command, semiactive radar homing, active radar homing, track via missile, or ground aided seeker. Radar weapons must detect, acquire, track, launch and guide (or fire a ballistic solution), and assess damage. Radar systems have trouble with ground clutter. To pick out targets from ground clutter, radar systems can detect movement through the use of moving target indicator, Doppler (continuous wave radar), or Pulse Doppler. Modern radar systems can track the movement of the aircraft, while some systems also detect the movement of rotor blades. A few older radar systems had blind speeds (called a Doppler notch), where they could not detect an aircraft flying a specific speed towards or away from the radar. Modern radar systems cancel blind speeds. Radar systems can be detected, avoided, decoyed, jammed, and destroyed by direct and indirect fires (self, artillery, and antiradiation missiles).

(2) Infrared. All IR direct threat weapons require LOS to be established prior to launch and the in-flight missile must maintain LOS with the target until impact (or detonation of the proximity fuse). IR missiles require the operator to visually detect the target and energize the seeker before the sensor acquires the target. The operator must track the target with the seeker caged to the LOS until it is determined that the seeker is tracking the target and not any background objects (natural or man made objects to include vehicles, the sun, or reflected energy of the sun off clouds, etc.). The IR sensor is also susceptible to atmospheric conditions (haze, humidity), the signature of the aircraft and its background, flares, decoys, and jamming. Generally IR systems are--

- Difficult to detect prior to launch (passive sensor).
- Difficult to predict where they may be located (portability).
- Difficult to respond to (short time of flight after launched).

- Difficult to hard kill (requires shooting at an in-flight missile).

(3) Laser and directed energy weapons. Laser/DEW weapons really fit two distinct categories--laser guided or aided weapons and pure laser/DEW weapons. Laser guided, or aided weapons, are those who use the laser to perform ranging, tracking, or guiding functions for conventional explosive missiles or projectiles. Pure laser/DEW weapons use Laser and other forms of DEW to inflict damage to the aircraft or its sensors, including the eyes of the aircrews. Pure laser/DEW weapons are not required to burn a hole in the target to destroy it (although these weapons are reaching that capability). Simply igniting fuel vapor near vents or burning through fuel lines are effective, as well as glazing the cockpit glass so the aircrew cannot see out. Inherently, laser/DEW weapons are short duration, hard to detect, extremely hard to decoy or jam, and hard to kill. Fortunately they must rely upon LOS, certain atmospheric conditions, and are somewhat short range, at present.

(4) Optical/electro-optical. Optical/EO sensors are used as either the primary or secondary sensor for all weapon systems. Although they rely upon LOS, they are, with very few exceptions, completely passive. They are limited by human eyes, atmospheric conditions, distance, operator movement, and in many cases, by darkness. The optical/EO sensors are most difficult to detect and seldom can be decoyed; however, they can be jammed by obscurants, and when located, can be hard killed.

G-3. AIRCRAFT SURVIVABILITY EQUIPMENT SYSTEMS

a. Aircraft Signature Reduction. All cargo and utility helicopters are painted with nonreflecting IR absorbing paint. UH-60 and EH-60 aircraft are equipped with HIRSS, which reduces the IR signature by suppressing hot exhaust gases. HIRSS aids the effectiveness of the AN/ALQ-144A IR missile jammer. CH-47 aircraft do not presently have exhaust suppression. The CH-47 aircraft are protected from IR missiles by the combination of the AN/ALQ-156 countermeasures set and the M-130 flare dispenser. The radar and IR signature of utility and cargo helicopters is least when viewed from the front. The maximum IR signature is from the rear quadrants, whereas the maximum radar signature is from the side aspects. The aircrews have the ability of decreasing the signature exposed to threats by changing the aspect of the aircraft. This is least effective in the CH-47 aircraft.

b. Aircraft Survivability Equipment Suites.

(1) EH-60 aircraft survivability equipment suite capabilities. The EH-60 ASE suite provides for PW radar and CW radar signal detection, CW radar jamming, and decoying for radar directed threats. Additionally the ASE suite provides omnidirectional IR jamming and decoying for IR directed threats. The aircraft signature reduction capabilities includes both nonreflective IR absorbing paint and HIRSS, which suppresses hot exhaust gases (see Figure G-1).

(2) UH-60 aircraft survivability equipment suite capabilities. The UH-60 ASE suite provides for PW radar and decoying for radar directed threats. Additionally the ASE suite provides omnidirectional IR jamming for IR directed threats. The aircraft signature reduction capabilities include both nonreflective IR absorbing paint and HIRSS, which suppresses hot exhaust gases (see Figure G-1).

(3) CH-47 aircraft survivability equipment suite capabilities. The CH-47 ASE suite provides for PW radar signal detection for radar directed threats. Additionally the ASE suite provides omnidirectional IR decoying for IR directed threats. The aircraft signature reduction capability consists of nonreflective IR absorbing paint only (see Figure G-2).

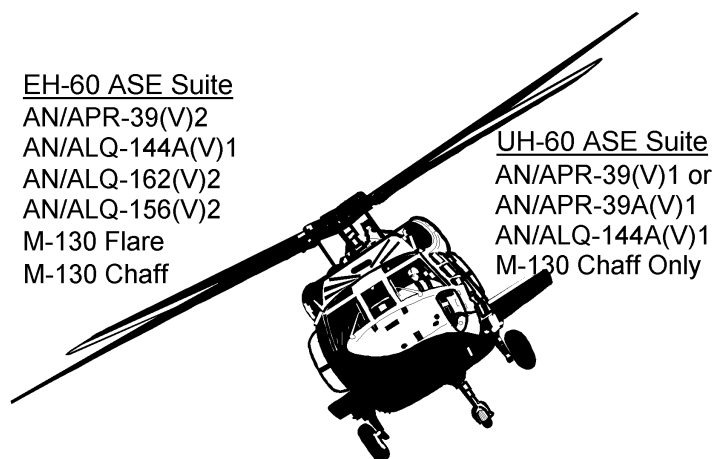

Figure G-1. EH-60 and UH-60 ASE suites

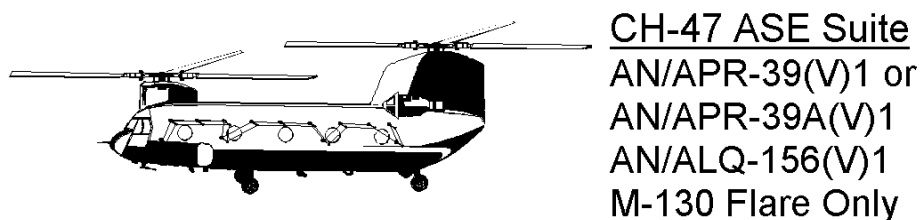

Figure G-2. CH-47 ASE suite

c. Situational Awareness. All cargo and utility aircraft are equipped with PW RSDS (such as AN/APR-39(V)1, AN/APR-39(V)2, or AN/APR-39A(V)1), which provide the aircrew with alerts of radar activity. Aircrews use the cues from the RSDS to change modes of flight (contour to NOE) or to increase vigilance by actively seeking terrain features for masking. EH-60 aircraft also detect the presence of CW radar through the use of the AN/ALQ-162 continuous wave radar jammer.

d. Active Countermeasures. ASE countermeasures assist the aircrew in buying time when masking terrain is not readily available, and the aircraft must maneuver to masking terrain or move outside the threat range. IR threats can be jammed by AN/ALQ-144A(V)1 or through the combined use of the AN/ALQ-156(V)2/3 and the flare equipped M-130 general purpose dispenser. Radar threats can be decoyed by use of the M-130 with chaff. CW radar can be jammed by the AN/ALQ-162(V)1.

e. Radar Warning Receivers.

(1) AN/APR-39(V)1 radar signal detecting set. The AN/APR-39(V)1 RSDS is the basic version of RSDS, which uses a signal comparator, signal intensity strobe display, and audio cues to provide detection of PW radar. It provides coverage for C/D and E through J band PW radar. The system has the capability of detecting all pulse radars normally associated with hostile SAM, airborne intercepts, or anti-aircraft weapons. Indications require direct aircrew interpretation since this system has no EID software.

(2) AN/APR-39(V)2 radar signal detecting set. The AN/APR-39(V)2 RSDS is a special version of RSDS, which uses a digital processor and alphanumeric display to provide detection of PW radar for special electronic mission aircraft. It provides coverage for C/D and E through J band pulsed wave radar. The system has the capability of detecting all pulse radars normally associated with hostile SAM, airborne intercepts, or anti-aircraft weapons. The EID software is reprogrammable and must be specific theater selected before flight.

(3) AN/APR-39A(V)1 radar signal detecting set. The AN/APR-39A(V)1 RSDS is an

upgraded version of the AN/APR-39(V)1, which uses a digital processor, alphanumeric symbology display, and synthetic voice warning to alert the aircrew to the presence of radar directed air defense threat systems. It provides coverage for C/D and E through M band PW radar. The theater specific EID software is reprogrammable.

f. AN/ALQ-144A(V)1 Countermeasure Set. This CMS is an active, continuously operating omnidirectional, IR jammer system for helicopters, designed to confuse or decoy threat IR missile systems. The AN/ALQ-144A(V) CMS is designed to provide jamming of all known threat IR missile systems, and it must be operated on an aircraft equipped with low reflective paint and engine exhaust suppressers. The system has specific jam program number settings that must be set prior to flight (see Figure G-3).

g. AN/ALQ-162(V)2 Countermeasure Set. This CMS provides warning and protection against SAM and airborne intercept missiles using CW illuminator radar for guidance. The CW signals detected by the system will be validated, and jamming initiated, in conjunction with threat identification given to the aircrew. The specific action taken by the system is determined by warning and jamming thresholds programmed into the system. The system has specific jam settings that must be set prior to flight.

h. AN/ALQ-156(V)1/2 Countermeasure Set. This CMS is an airborne radar system that provides protection to the aircraft by detecting the approach of anti-aircraft missiles. Upon detection, the missile detector automatically initiates a signal that triggers the M-130 general dispenser system. The dispenser system releases a flare to decoy an IR seeking missile away from the aircraft.

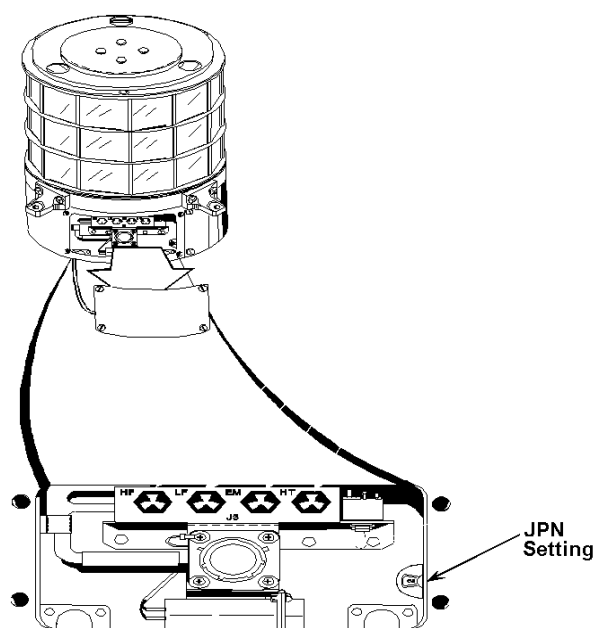

Legend: See the glossary for acronyms and abbreviations.

Figure G-3. AN/ALQ-144A(V)1 CMS

i. M-130 General Purpose Dispenser. The M-130 dispenses chaff and flares. The system is operated manually or automatically through interface with other countermeasure systems. The chaff provides protection against radar directed anti-aircraft weapon systems, while the flares provide protection against IR directed missile systems. When dispensing chaff, the M-130 reduces or eliminates the enemy's ability to hit and destroy aircraft by use of radar-controlled, anti-aircraft weapons. When dispensing flares, the M-130 reduces or eliminates the enemy's ability to hit and destroy aircraft by use of IR guided missiles. When the M-130 is set to dispense chaff, the electronic control module must have the program setting installed prior to flight.

j. Tactical Operations Officer. For ASE to provide effective protection during a mission, configuration settings must be optimized for the threats encountered. The TOO at the brigade and battalion staff will assist the S3 operations officer in mission planning for aircraft survivability

during mission accomplishment. TOE place the TOO in the aviation company as a CW3, in the battalion operations as a CW4 (CW5 at battalion for CH-47 Battalions), and in the brigade as a CW5. TOO is identified by the SQI I (such as 153BI). The ASE/EW officer is a CW2 in the aviation company. ASE/EW officer is identified by the ASI H3 (such as 153B0H3) ASE/EW officer ensures optimum ASE configurations settings are prepared for each flight.

G-4. OPERATIONAL EMPLOYMENT CONSIDERATIONS

a. Aircraft survivability functions must be included throughout mission planning, rehearsal, execution, and recovery operations. Mission planning begins with the receipt of the mission. It continues through mission execution, including the after-action review. It is important to plan and implement aircraft survivability functions when receiving the mission and enemy situation. Figure G-4 shows staff responsibilities for EW planning.

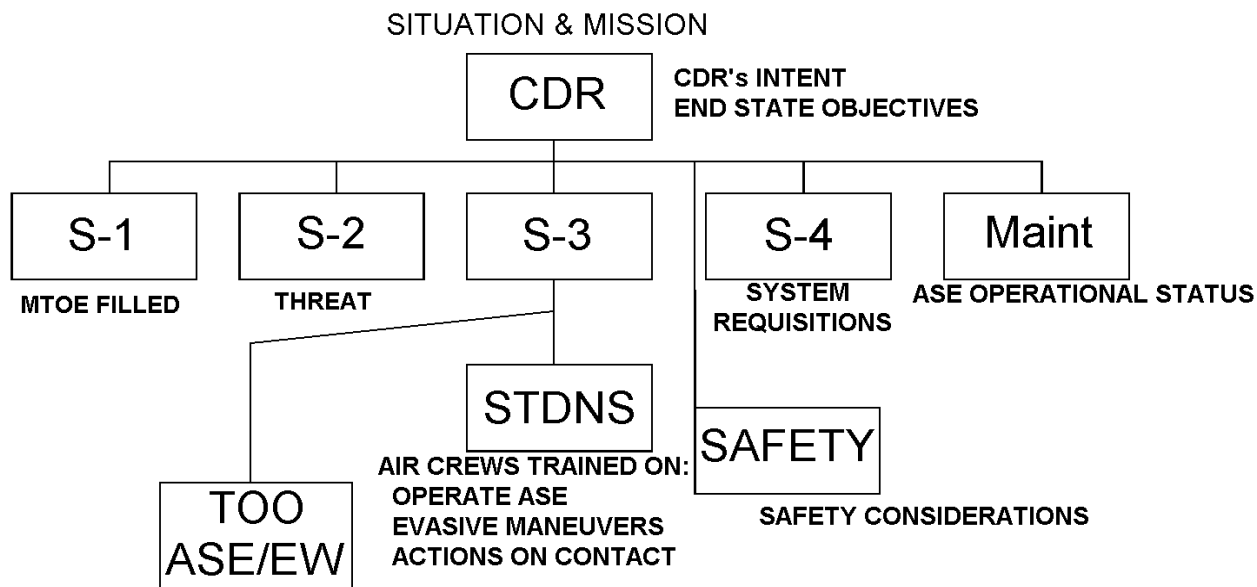

WHAT IS PRIORITY OF THREATS?
 COUNTERMEASURES EFFECTIVE?
 DETECT/NOT DETECT?
 JAM AND DECOY/NOT JAM / NOT DECOY?
 OPTIMUM ASE SETTINGS FOR MISSION?
 RISK REDUCTION OF NONCOUNTERED THREATS?

Legend: See the glossary for acronyms and abbreviations.

Figure G-4. Roles and functions

b. ASE and EW must be considered in all phases of mission planning. The level of planning involved is always predicated on the time, information, and personnel available. OPLANs and OPORDs for military operations are extensive in scope and contain information that serves as a baseline for most unit operations.

c. The generation of the OPORD begins upon receipt of the enemy and friendly situation, the mission, and the commander's intent. Figure G-5 links EW planning with OPORD/FRAGO development. The EW annex (Figure G-6) is created to support the OPORD or OPLAN, using this information. The enemy and friendly situations are further defined with the emphasis on the EW capabilities of both, and their ability to find, fix, jam, deceive, disrupt, or destroy each other. Once the situation is clearly defined, the mission is analyzed to evaluate the risk to friendly forces, while accomplishing the mission within the prescribed guidelines. After the risk assessment is complete, risk reduction techniques are specified in the execution instructions. These techniques may require the commander's approval if the mission constraints need to be altered significantly from the original intent. The next step is to determine service support for EW and the command and signal guidance necessary to accomplish the EW phase of the mission.

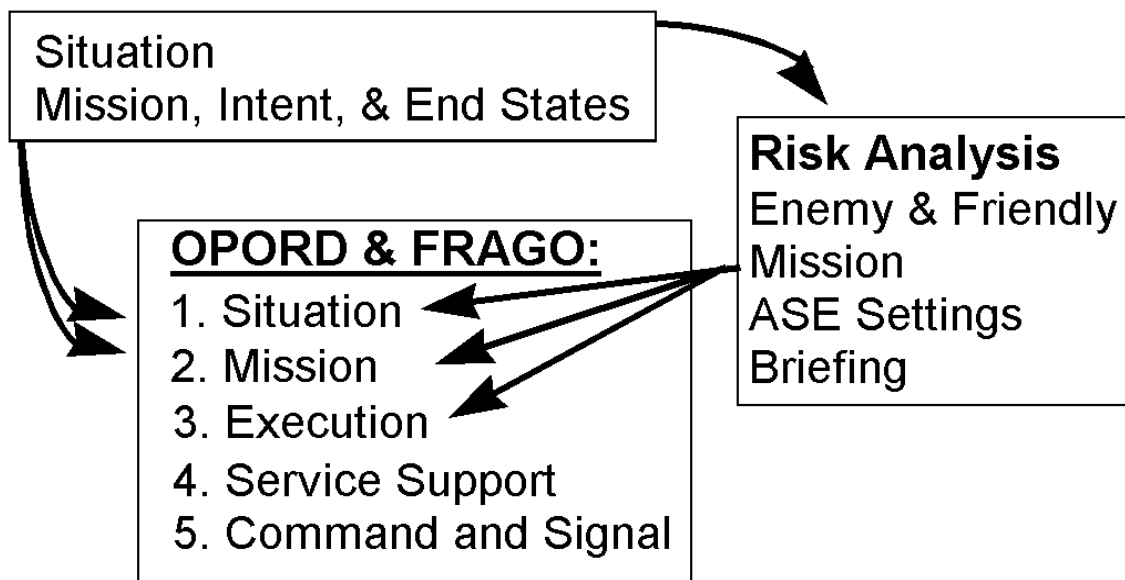

Legend: See the glossary for acronyms and abbreviations.

Figure G-5. OPORD and FRAGO

SECURITY CLASSIFICATION	
	ISSUING HEADQUARTERS LOCATION DAY, MONTH, YEAR, HOUR, ZONE
<u>ANNEX I (ELECTRONIC WARFARE) TO OPORD XXXX-XX (U)</u>	
() References: List basic documents required.	
1.	<p>() <u>Situation</u></p> <p>a. () <u>Enemy</u>. Refer to annex B. Provide an estimate of the enemy's communications, noncommunications, and EW systems capabilities, limitations, and vulnerabilities including the ability to interfere with the accomplishment of the EW mission stated herein. Determine the ability to detect radar altimeter, Doppler, ALQ-156, FM, VHF, and UHF communications, and the ability to interrogate transponder for modes 1, 2, 3A, and 3C. Determine air defense EW systems and analyze parameters (frequencies, PRF, PRI, scan type, wavelength, etc.) for use in risk analysis.</p> <p>b. () <u>Friendly</u>. Provide a list of friendly EW systems available for the mission (such as communications, noncommunications, navigation, sensors, countermeasures, electro-optical systems). Include friendly EW assets that can exploit and disrupt the enemy's usage of the electromagnetic spectrum.</p> <p>c. () <u>Assumptions</u>. State any assumptions about friendly or enemy EW capabilities and possible courses of action that may influence the planning or execution of EW operations.</p>
2.	() <u>Mission</u> . State the EW operations necessary to support the mission in the basic plan.
3.	<p>() <u>Execution</u></p> <p>a. () <u>Concept of operations</u>. Summarize the scope of EW operations and the methods and resources to be used. Include TTPs for the threats that may be encountered.</p> <p>b. () <u>Tasks</u>. In separate subparagraphs, assign individual tasks to EWOs and crews, including instructions</p>

b. () **Tasks.** In separate subparagraphs, assign individual tasks to EWOs and crews, including instructions and references.

c. () **Coordinating Instructions.** Place instructions applicable to two or more subunits in the final subparagraph.

1. () **Guiding Principles.** State, or refer, to policies, doctrine, tactics, techniques, and procedures that provide guidance to be followed. Establish any additional guidance and authorized deviations from standardized practices. Describe any constraints that may apply to the mission.

2. () **Special Measures.** Provide any special procedure to be used that is not provided elsewhere.

Figure G-6. Suggested format for an EW annex to OPORD

4. () **Service Support.** Specify support units to provide EW service support. Include verification of threat parameters and ASE settings through the army reprogramming analysis team.

5. () **Command and Signal.** Provide information on IFF mode settings and mode activation/deactivation line, ASE configuration settings, Have Quick settings, SINCGARS settings, A²C² frequencies, AWACS contact points, brevity codes, etc.

Acknowledge:

Name (Commander's last name)

Rank (Commander's rank)

OFFICIAL:

APPENDICES:

DISTRIBUTION:

(SECURITY CLASSIFICATION)

(This sample EW appendix is unclassified, but when actually accomplished should show proper classification markings of each paragraph.)

Legend: See the glossary for acronyms and abbreviations.

Figure G-6. Suggested format for an EW annex to OPORD (concluded)

G-5. ELECTRONIC WARFARE RISK ASSESSMENT

a. To perform a thorough risk assessment, detailed information about threat system operating procedures, tactics, system capabilities, and locations must be analyzed to determine the enemy's advantages or disadvantages in the use of EW. The capabilities and limitations of friendly EW systems must be compared to the threats to assess the level of risk associated with the mission. During mission planning, the following threats must be identified:

- Operating frequencies of radar threats.
- RF threats that can, or cannot, be detected.
- RF threats that may be affected by radar jamming equipment.
- RF threats that can be decoyed.

- IR threats that may be encountered.
- IR threats that can be detected.
- IR threats that can be jammed or decoyed.

b. The threat systems should be prioritized and the ASE settings optimized for the highest priority threats. Determine the level of risk based on the threat's capabilities and limitations, the capabilities and limitations of the ASE, and the mission. Figure G-7 shows a suggested format for a worksheet used to assess EW risk. Lethal threats that cannot be countered by ASE, must be identified and PIR developed and submitted to higher. For example, the SA-X is very lethal and no organic ASE counters it. This threat would pose a high risk to mission accomplishment and must be located within the AOs to ensure aircrew safety. Apply risk reduction techniques to minimize the risk and enhance the probability of survival. Risk reduction measures are as follows:

- Plan mission time earlier or later to take advantage of night operations.
- Use only suppressed aircraft for the higher risk portions of the mission.
- Request escort aircraft to suppress threats.
- Plan SEAD at critical points to reduce vulnerability.
- LZ/PZ preparation with indirect fires.
- Alter flight routes to avoid known air defense areas.
- Deception plan to include false insertion.
- Signature reduction (EMCON).
- Adjust formation/sortie size.

c. The ASE/EW mission briefing disseminates information and instructions to the aircrews prior to the mission. The briefing will alert aircrews to the risks associated with the threats, the optimum ASE settings, and a review of the tactics specific to the mission. These tactics include evasive maneuvers, actions on contact, multiship breakup and reformation procedures, and rules of engagement for countermeasures employment and crew served weapons.

d. Once the OPORD (and EW Annex) is generated, it becomes the base document. For specific missions, complete OPORDs may not always be required. In these instances, FRAGOs outlining the changes from the basic OPORD are created and issued to affected units. Upon receipt of the FRAGO, the staff planners must evaluate the information available and revalidate the EW Annex. Any changes to the EW Annex must be detailed and disseminated to the aircrews as part of the mission briefing. Figure G-8 is a suggested format for an ASE/EW mission briefing to assist EWOs in completing this task.

Survivability Risk Analysis

ACFT Type: _____ **Mission:** _____ **Date:** _____

Mission Profile:		<100' AGL	>100' AGL	Value: _____
	Night	Low	Medium	
	Day	Medium	High	

IR Threats:		Suppressed	Unsuppressed	Value: _____
	IRCM	Low	Medium	
	Non-IRCM	Medium	High	

RF Threat:		Warning	No-Warning	Value: _____
	IRCM	Low	Medium	
	Non-IRCM	Medium	High	

E/O Threat:		Low Visibility and Contrast	High Visibility and Contrast	Value: _____
	Masking	Low	Medium	
	No-Masking	Medium	High	

Laser/DEW Threat:		Warning	No-Warning	Value: _____
	Masking	Low	Medium	
	No-Masking	Medium	High	

Highest Value: _____

Overall Risk:

	Reevaluate mission profile, ASE, or flight routes.	Low
	Reevaluate mission profile, ASE, or flight routes.	Medium
		High

Priority Threats:

IR:	A	B	C	D
RF:	A	B	C	D
E/O:	A	B	C	D
Laser/DEW:	A	B	C	D

ASE Configuration Settings:

ALQ-144: _____
 ALQ-162: _____
 APR-39A(V)1: OFF: _____
 APR-39A(V)2: _____
 M-130 Chaff PRGM: UH-60: _____
 ALQ-156: _____
 IFF: Mode1 Mode2 Mode3A Mode3C Mode4

EID: _____ EH-60: _____	IR=Infrared IRCM=IR Countermeasures Suppressed=IR Paint & Exhaust RF=Radio Frequency RFCM=RF Countermeasures E/O-Electro-Optical
--	---

Legend: See the glossary for acronyms and abbreviations.

Figure G-7. Suggested format for a risk assessment worksheet

ASE/EW Briefing

OVERALL RISK: Low Medium High

CAUSED BY: Mission Profile
 ASE Suite
 Threat

ASE and IFF Configuration Settings:

ASE can detect:

ASE cannot detect:

ASE can jam:

ASE cannot jam:

Primary Threats: IR
 RF
 E/O
 Laser/DEW

Risk Reduction Measures:

Changes to Standard TTPs:

QUESTIONS:

Legend: See glossary for acronyms and abbreviations.

Figure G-8. Suggested format for an ASE mission brief

e. During the conduct of mission execution it is important for aircrews to be familiar with the ASE situational awareness displays and the expected threat indications. Some actions must be performed without delay. When the visual indications reveal a gun or missile being fired at the aircraft, or the ASE indicates a radar track or launch, the aircrew has limited time to perform an action preventing the aircraft from being engaged. Crew coordination of evasive maneuver performance must be rehearsed, and standardized terminology, such as "missile three o' clock, break right," used to avoid confusion. There are situations when evasive maneuvering is not required, such as during radar search or acquisition. Three distinct elements of reacting to threat engagements are--

- Indication (determine immediate actions).
- Evasive maneuver (when masking terrain is not readily available).
- Actions on contact (decision to continue or abort mission).

f. Formation types, and spacing intervals, should be selected to provide all aircraft the necessary maneuver space for hostile fire avoidance. Standardized terminology, such as "chalk two breaking right...missile" or "chalk three breaking left...tracers at nine o' clock," should be used to alert the flight to your actions. Briefings should include evasive formation break up procedures and the method for reforming after breaking the engagement. It is important to communicate your ASE indications to other aircraft in the formation, since you may be the only aircraft receiving indications, due to terrain, narrow radar beam, altitude, or maintenance problems.



APPENDIX H

FLIGHT CREW MISSION BRIEF

H-1. PURPOSE

The purpose of this appendix is to present a suggested format for a flight crew mission brief. Flight crews should be thoroughly briefed by the utility and cargo battalion staff prior to executing any air movement mission. A detailed OPORD or AB may not be necessary for small scale air movement missions, but no flight crew should depart the AA without understanding their mission. This is a suggested format for a flight crew mission briefing that can be used to brief aircrews conducting air movement operations.

H-2. AIR MOVEMENT FLIGHT CREW MISSION BRIEF

Figure H-1 is a suggested format for a flight crew mission brief.

1.	SITUATION
	<ul style="list-style-type: none"> a. Enemy. <ul style="list-style-type: none"> (1) Weather effects on operations (2) Locations of enemy units or activities in the area of operations (the area the aircraft will be operating in) (3) Significant enemy activity in the aircraft AO (4) Location of known or suspected enemy ADA assets b. Friendly. <ul style="list-style-type: none"> (1) Location of friendly units in the area of operations (center of mass for battalion sized units should be sufficient)

Figure H-1. Suggested format for a flight crew mission brief

- (2) Standardized layout of COSCOM, DSA, and BSA, if known.
 - (3) Locations of artillery and ADA units operating in the division and/or corps rear areas (Patriot, MLRS, Corps Arty).
 - (4) Locations of friendly aviation unit AAs in the AO that could provide support, if necessary.
2. **MISSION.** Who, what, when, where, and why for the aircrews conducting the air movement mission.
 3. **EXECUTION.**
 - a. **Commander's Intent.** A clearly defined intent as to the purpose and end state of the air movement mission being flown. Commander's may not personally issue this intent for small scale air movements (one or two aircraft). However, the briefer (normally the S3 or Battle Captain) should receive the intent for the commander and issue it to the aircrews so they understand completely their task, purpose, and end state.
 - b. **Coordinating Instructions.**
 - (1) **Command and Control/POC.** Define who the aircraft are working for, and who the point of contact is at the supported unit.
 - (2) **Aircraft loading requirements.**
 - (a) Is cargo to be loaded internally or externally?
 - (b) Load weights.
 - (c) Load rigging and inspection responsibility.
 - (d) Type cargo to be hauled.
 - (e) Disposition of the slings after movement of external loads.

Figure H-1. Suggested format for a flight crew mission brief (continued)

(f) Dropped load procedures.

(g) Special considerations for loads (ammo, fuel, etc).

(3) CSAR/downed aircrew procedures. Aircraft on this mission may be operating out of communications range from the parent headquarters and are susceptible to mission changes once supporting another organization. Therefore, it is essential that these aircrews understand CSAR procedures and each individual aircrew EPA.

(4) A²C². Review the current ACO with the aircrews conducting the mission and determine what A²C² measures will be used during the mission.

(5) LZ/PZ procedures.

(a) Call signs and frequencies for PZs and LZs.

(b) Locations of all possible PZs and LZs (COSCOMs, DSAs, and BSAs may have different LZs for different classes of supply. Locations of actual LZs and PZs need to be passed, not a center of mass location for the BSA, DSA, or DISCOM.

(6) Additional fratricide prevention controls in effect.

4. SERVICE SUPPORT.

a. Fuel.

(1) Location of parent unit main FARP, call sign, landing procedures.

(2) Location of other unit FARPs in the area of operations, call sign, frequency, and landing procedures.

(3) Refuel procedures if the refueling operation will be conducted at the COSCOM, DSA, or BSA.

Figure H-1. Suggested format for a flight crew mission brief (continued)

- b. **Ammunition.** Location of ammunition and amount to be carried on the mission for the aircraft door guns.
 - c. **Maintenance Support.**
 - (1) Location of maintenance contact teams and frequency for contacting if problems arise during run-up.
 - (2) Location of other aviation maintenance units in the area of operations that could provide maintenance assistance if needed.
5. **SIGNAL.**
- a. Frequencies and call signs of all supported units for the mission.
 - b. Flight following procedures and required SITREP calls back to the parent headquarters. (This may be done using a retransmission and FM communications, or it may be done via MSE.) Whatever method is chosen, the aircrews need to understand their requirements for keeping the parent headquarters informed of their mission status.
 - c. SOI edition that is in effect.
 - d. IFF procedures (codes that are in effect).

Legend: See the glossary for acronyms and abbreviations.

Figure H-1. Suggested format for a flight crew mission brief (concluded)



APPENDIX I

ASSEMBLY AREA OPERATIONS

I-1. GENERAL

The purpose of this appendix is to discuss AA operations for the utility and cargo helicopter unit. An AA is a location where the utility and cargo helicopter unit prepares for future operations, issues orders, accomplishes maintenance, and completes resupply activities. The AA for the utility and cargo helicopter unit will be as varied as these organizations are, from fixed based airfields to remote field sites. Regardless of the type of AA the unit will occupy, certain principles must be adhered to by the commander and staff to ensure the survivability of the unit. AAs are usually located in the corps or division rear area and in or near the aviation brigade AA. Aviation AAs are usually located out of the range of enemy artillery and should be large enough to ensure adequate dispersion of units. An AA must provide--

- Security.
- Concealment.
- Accessibility to MSRs.
- Air avenues of approach.
- Proximity to friendly units.
- Suitable ingress and egress routes.

I-2. ASSEMBLY AREA RESPONSIBILITIES

In all cases, the commander must designate who is responsible for the selection, occupation, and securing of the unit AA. Responsibilities for the AA are listed below. The commander may decide to assign these responsibilities to other people.

a. Battalion S3. The responsibilities of the battalion S3 are to--

- (1) Select future main CP sites.

- (2) Select site for the TOC within the main CP.
- (3) Develop an R&S plan in conjunction with the S2.
- (4) Establishes a jump, or temporary, TOC, if necessary, until the TOC is established at the main CP site.
- (5) Develop plans and orders for moving the AA, if directed by the commander.
- (6) Plan for air routes and conduct airspace management for the air routes to the new AA.
- (7) Plan for fires to support the AA move.
- (8) Develop a plan for reconnaissance of the movement routes and new AA location.
- (9) Plan, and request support if necessary, for MEDEVAC assets to assist during the move.
- (10) Coordinate with higher headquarters or adjacent units for land to establish an AA.
- (11) Request engineer support to assist in AA improvement.
- (12) Coordinate and request air defense support for the AA.

b. Battalion Executive Officer. The responsibilities of the battalion XO are to--

- (1) Establish timelines for AA moves.
- (2) Develop triggers, based upon a decision support template (developed by the S2), for displacement of the AA.
- (3) Conduct a rehearsal of AA moves and occupations.

c. Command Sergeant Major. The responsibilities of the battalion CSM are to--

- (1) Assist the S3 and S4 in the development of movement orders.
- (2) Supervise the break down of the AA.
- (3) Lead the quartering/advanced party, as directed by the commander.
- (4) Supervises the establishment of the new AA.

d. Battalion S4. The responsibilities of the battalion S4 are to--

- (1) Develop plans and orders for moving the AA, if directed by the commander.
- (2) Develop march tables for the vehicle convoy to the new AA.
- (3) Select the location for the ALOC within the main CP.

e. Headquarters and Headquarters Company Commander/First Sergeant.

The responsibilities of the HHC commander/1SG are to--

- (1) Organize the march serials, designates serial commanders, and conducts convoy briefings.
- (2) Lead the quartering/advanced party, as directed by the commander.
- (3) Select locations for future AAs in conjunction with the S3.
- (4) Conduct a reconnaissance of proposed AA sites.
- (5) Select emergency displacement AAs.

f. Battalion S2. The responsibilities of the battalion S2 are to--

- (1) Develop an event template and DST for the AA, which results in DPs necessary for planning and executing AA displacement.
- (2) Develop NAIs in the vicinity of the AA and assists the S3 in developing an R&S plan for the AA.
- (3) Track the enemy situation in relation to the displacement decision points and inform the commander when the enemy reaches the selected DPs.
- (4) Assist the HHC commander and S3 in selecting new AAs by conducting a threat and terrain analysis of the proposed AA location.

g. Communications-Electronics Officer. The responsibilities of the communications-electronics officer are to--

- (1) Analyze potential AA sites and determines their suitability in terms of providing communications for the battalion
- (2) Establish a retransmission, if required to assist during unit moves.
- (3) Analyze potential AAs for their proximity to MSE nodes.

I-3. ASSEMBLY AREA OCCUPATION

The AA is a battalion position. It is chosen based upon the mission of the battalion, a map reconnaissance, and a physical reconnaissance of the selected area. Once an AA has been selected and coordinated, it is occupied when the unit receives the order to move to and occupy the new AA. Occupation of the AA should be well planned and rehearsed. Occupation of an AA is a four phase operation--

- Phase 1: Reconnaissance.
- Phase 2: Quartering party/advanced party operations.
- Phase 3: Main body arrival (air and ground).
- Phase 4: AA improvement.

a. *Reconnaissance.*

(1) Area reconnaissance. An area reconnaissance of the AA location and the surrounding terrain should be accomplished as soon as possible after the AA site has been selected. This area reconnaissance may be conducted by air or ground. If the reconnaissance is conducted by air, the aircraft should land and allow the reconnaissance party to physically walk and observe the layout of the terrain. Items to be looked for during the AA reconnaissance include suitability of the area, NBC contamination (if in a suspected NBC area), enemy activity, and concealment.

(2) Route reconnaissance. A route reconnaissance of the convoy routes should be conducted prior to the movement to the new AA location. The commander may elect to use battalion aircraft to conduct this reconnaissance. The purpose of this reconnaissance is to verify the suitability of the convoy route, locate any areas along the route that will cause delays for the convoy, determine if there is traffic on the route, and look for enemy in the area that can influence the convoy. The route reconnaissance should be conducted prior to the quartering

party movement. The commander may elect to conduct continuous reconnaissance along the route during the duration of the convoy.

b. Quartering Party/Advanced Party Operations. The quartering party consists of the quartering party and the advanced party. The quartering party conducts to initial occupation of the AA, which includes a reconnaissance for security and NBC contamination if it is suspected. The advanced party conducts an initial set up of the AA and prepares the site for the arrival of the main body. The quartering party and advanced party may move together or be separated by a time interval. If they move together, the advanced party will stop at a designated point outside the new AA and wait for the quartering party to finish their operations, and the advanced party will occupy the new AA. The quartering party and advanced party are normally led by the CSM, HHC Commander, HHC 1SG, or others as designated by the commander. Specific responsibilities are listed below.

(1) *Quartering party.* The responsibilities of the quartering party are to--

(a) Conduct reconnaissance. (NBC reconnaissance should be conducted if NBC contamination is suspected or likely. Prior to movement, the S2 should be consulted to determine the likelihood of NBC contamination in the new AA.)

(b) Establish security. Security at this point may consist of establishing OPs along the most likely enemy avenues of approach.

(2) *Advanced Party.* The advanced party conducts their operations after completion of the quartering party reconnaissance. The advanced party--

(a) Establishes security.

(b) Establishes communications with the TOC in the AA.

(c) Determines the locations of the TOC, ALOC, company elements, and FARP.

(d) Confirms suitability of the area.

(e) Clears any safety hazards from the area.

(f) Establishes internal wire communications to the company areas.

(g) Clears and marks aircraft parking positions.

(h) Establishes LP/OPs and dismount point.

(i) Emplaces M8 alarms.

c. *Main Body Arrival (Air And Ground).* The main body of the battalion should arrive in two parts, beginning with the ground vehicles and followed by the aircraft.

(1) *Ground arrival.* When the ground vehicles arrive, they are met by members of the advanced party who guide them along a selected route to each company's position. The priority of tasks upon closure of the main body is to--

(a) Establish security. The type and amount of security are dependent on the factors of METT-T, and may range from establishing LP/OPs along the most likely enemy avenues of approach to full perimeter security. The CSM must consult with the S2 to determine the threat and establish security that will meet that threat.

(b) Reestablish the TOC. Communications should be established with higher headquarters as soon as possible after occupation of the AA.

Note: Communications with higher headquarters must never be lost. The advanced party must establish communications with higher headquarters prior to the TOC breaking down and moving.

(c) Camouflage.

(d) Establish individual fighting positions and survivability positions ("flop holes" designed to be used in the case of attacks by indirect fire).

(e) Establish crew served weapons fighting positions.

(f) Establish a dismount point.

(g) Coordinate with adjacent units for security. Ensure that coordination and communications with adjacent units are established if the adjacent unit is within range of the battalion's direct fire weapons systems.

(h) Develop an R&S plan. The S2 develops NAIs, and the S3 develops a plan to keep the NAIs under observation.

(i) Submit sector sketches. Companies submit sector sketches to the battalion for incorporation into the battalion security plan.

(j) Establish a QRF.

(k) Conduct accountability of all personnel and weapons.

(2) Air arrival. Battalion aircraft should arrive after the ground portion of the main body. During AA movement, the battalion must consider and make provisions for maintaining communications with the battalion aircraft located at the previous AA site. When the aircraft arrive they should be positioned in a predetermined location selected by the advanced party. The location of the aircraft should provide the maximum concealment possible. The aircraft should not park too close together. Upon arrival, aircrews should complete a post flight inspection, report any problems to the commander, and assist in the establishment of the AA.

d. Assembly Area Improvement. The AA is continuously improved as time allows. Some key areas that require improvements are field sanitation, ground obstacles, camouflage, and maintenance and living conditions. Continuous camouflaging must be conducted to reduce the radar, heat, noise, electronic, and visual signatures of the battalion.

I-4. ASSEMBLY AREA SECURITY

Security of an AA is a difficult task for all aviation units. Limited personnel makes this a

challenging, but not impossible, task. The utility and cargo helicopter unit can accomplish the basics of AA security, which leads to force protection.

a. Obstacles. All roads that lead into the AA that are not necessary for AA operations should be blocked with obstacles and covered with fire. Obstacles may be natural or man-made. Assistance in emplacing obstacles may be necessary. The battalion may have to coordinate with higher for engineer assistance in developing obstacles.

b. Fighting Positions. The utility and cargo unit establishes crew served fighting positions that cover the most likely enemy avenues of approach. The fighting positions should be continuously occupied. Range cards must be prepared and present, so that new guard shifts are aware of their responsibilities in securing the AA.

c. Listening Posts/Observation Posts. The battalion may establish LP/OPs in the vicinity of the AA. The purpose of these locations is to provide early warning to the battalion of anyone approaching the AA. LP/OPs should be placed along the most likely enemy avenues of approach and far enough away from the AA to provide adequate warning to the battalion of impending attack. The LP/OP must maintain communications with the TOC.

d. Dismount Point. The battalion may establish a dismount point to control the flow of traffic in and out of the AA. If engineer support is available, the remainder of the AA may be blocked (berms may be established around the AA). The dismount point controls traffic flow in and out of the AA and raises suspicion on any vehicle that is approaching the AA from a direction other than the dismount point.

e. Indirect Fire. The battalion may plan indirect fire in the vicinity of the AA. Final protective fires are established to protect the battalion during a displacement due to enemy attack. The LP/OPs may also have responsibility for fire support targets within their area. When planning indirect fire for the AA, the commander must develop an observer plan.

f. Assembly Area R&S Plan. The S2 and S3 work together to establish an R&S plan for the battalion. The S2 does a thorough analysis of the area and develops NAIs. The S3 develops a plan for reconnaissance of those NAIs. The reconnaissance plan may consist of aerial reconnaissance by battalion aircraft, or it may consist of ground reconnaissance by LP/OPs or ground vehicles.

g. Displacement Assembly Areas. The battalion must establish locations for both the ground vehicles and aircraft to scatter to in the event of an emergency displacement. These areas may not be the same place. As soon as possible after arrival at the AA site, scatter locations must be selected. All battalion aircrews and vehicle drivers must know the location of the scatter site and the route to get to the site. Strip maps should be prepared for each vehicle and aircraft, and a sketch of the emergency displacement plan should be located in the TOC.

h. Friendly Air Defense Artillery. Coordination should be made with friendly ADA units that may be in the vicinity of the AA. These units may be able to

provide the aviation unit with area air defense coverage of the AA. If not, the battalion can request from higher for air defense assets to cover critical battalion assets. Additionally, coordination should be made with friendly ADA units to ensure they are aware of the presence of friendly aircraft in the area. These ADA units may be able to assist in checking IFF equipment by interrogating battalion aircraft as they depart and arrive at the AA.

I-5. ASSEMBLY AREA DISPLACEMENT

A utility and cargo helicopter battalion is most vulnerable while occupying AAs. If the battalion comes under artillery, air, or ground attack, it will conduct an emergency displacement. The two types of plans for displacement are the surprise and early warning displacement. The displacement plan is part of the security for the AA and must be established as soon as possible after occupation of the AA. Displacement plans for each company will consist of the direction and route for leaving the AA, location of HAs, and alternate AAs. Areas to which the battalion will displace must be coordinated for through higher headquarters. Once established in the AA, the unit should conduct a rehearsal of the displacement to ensure all procedures are understood by the battalion elements.

a. *Surprise Displacement.* In the event of a surprise attack, the battalion will conduct an immediate displacement. Aircraft will depart individually if the situation allows. For survivability, it may be necessary for the flight crews to remain in their individual fighting positions or survivability positions until the immediate threat has passed before executing the displacement. Upon departing the AA, the aircraft move to the designated holding area or scatter site, conduct a reconnaissance, establish security, establish communications with the TOC or TAC, and transmit a situation report to the commander.

b. *Early Warning Displacement.* An early warning displacement occurs after thorough planning has been accomplished.

(1) *Establishing decision points.* During initial set-up of the AA, the S2 develops an event template and a DST for AA displacement. The DST results in DPs that the battalion commander can use as triggers for AA displacement. Once the DPs are determined, the S2 and S3 determine the best method for tracking the enemy situation in relation to the selected decision points.

(2) *Establishing readiness condition levels.* Based upon the decision points established by the S2, the commander designated REDCON levels for the battalion. As each decision point is reached, the battalion upgrades their readiness level and conducts sequential preparations for displacement. As the DPs are reached, the battalion gets more prepared to move, so when the enemy reaches the DP that calls for the AA to displace, the battalion is already prepared to move. Establishing REDCON levels ensures that the battalion is ready to move immediately when required and ensures that essential equipment is not left behind during the displacement.



GLOSSARY

ABBREVIATIONS AND ACRONYMS

A ² C ²	Army airspace command and control
AA	assembly area
AAA	antiaircraft artillery
AAFARS	advanced aviation forward area refueling system
AATF	air assault task force
AATFC	air assault task force commander
AB	aircrew brief
ABFP/BP	attack by fire position/battle position
ABN	air battle net
ACA	airspace coordination area
ACB	aircrew brief
acft	aircraft
ACL	allowable cargo load
ACO	airspace control order
ACP	air control point
ACR	armored cavalry regiment
ADA	air defense artillery
ADAO	assistant division aviation officer
ADE	assistant division engineer
ADRC	ARC digitized raster graphic
AHB	assault helicopter battalion
ALO	air/aviation liaison officer
ALOC	administrative/logistics operations center
ALSE	aviation life support equipment
ALT	altitude
AM	amplitude modulation
AMB	air mission brief
AMC	air mission commander
ammo	ammunition
AMPS	aviation mission planning system

ANCD	automated net control device
AO	area of operations
AOR	area of responsibility
AP	antipersonnel
APU	auxiliary power unit
AR	Army regulation/artillery
ARAT	Army reprogramming analysis team
ARI	Aviation Restructure Initiative
ASB	aviation support battalion
ASE	aircraft survivability equipment
ASI	additional skill identifier
AT	antitank
atk	attack
ATP	ammunition transfer point
AVIM	aviation intermediate maintenance
avn	aviation
AVUM	aviation unit maintenance
AWACS	airborne early warning and control system
AXP	ambulance exchange point
BDE	brigade
BN	battalion
BNTOC	battalion tactical operations center
BOS	battlefield operating system
BSA	brigade support area
C ²	command and control
C ³	command, control, and communications
CAB	command aviation battalion
CAC	command aviation company
CAN	combat aviation net
CAS	close air support
CASEVAC	casualty evacuation
CAT	category
CBT	combat
CCIR	commander's critical information requirements
Cdr	commander
CD-ROM	compact disk-read only memory
chem	chemical
CHEMO	chemical officer
CHSII	common hardware/software II
CMD	command

CMS	countermeasure set
CO	company
COA	course of action
COLT	combat observation lasing team
commo	communications
COMSEC	communications security
CONUS	continental United States
COSCOM	corps support command
CP	command post
CS	combat support
CSAB	combat support aviation battalion
CSAR	combat search and rescue
CSH	combat support hospital
CSM	command sergeant major
CSS	combat service support
CSS CP	combat service support command post
CW	continuous wave
DAD	department of the Army
DAO	division ammunition officer
DARP	downed aircrew recovery point
DART	downed aircraft recovery team
DCU	dispensing control unit
DEA	Drug Enforcement Administration
dept	departure
DEW	directed energy weapon
DISCOM	division support command
DMMC	division materiel management center
DMOC	division medical operations center
DOCC	deep operations coordination cell
DP	decision point
DS	direct support
DSA	division support area
DST	decision support template
DTC	data transfer cartridge
DTED	digital terrain elevation data
DTG	date-time group
E/O	electro-optical
E&R	evasion and recovery
EA	electronic attack
EAC	echelons above corps

ECC	Melectronic counter-countermeasure
ECM	electronic countermeasures
EEFI	essential elements of friendly information
EENT	end of evening nautical twilight
EID	emitter identification database
EMCON	emission control
eng	engine
EO	electro-optical
EP	electronic protection
EPA	evasion plan of action
ERFS	extended range fuel system
ES	electronic support
ESM	electronic support measure
EW	electronic warfare
EWO	electronic warfare officer
FA	field artillery
FARE	forward area refueling equipment
FARP	forward arming and refueling point
FAS	forward aid station
Fat Cow	A CH-47 configured with internal extended range fuel tanks that provide fuel to other aircraft.
Fat Hawk	A UH-60, configured with external fuel tanks, that provides fuel and ammunition to other aircraft.
FBI	Federal Bureau of Investigation
fld	field
FFIR	friendly force information requirements
FLIR	forward looking infrared
FLOT	forward line of own troops
FM	frequency modulated/field manual
FOB	forward operating base
FRAGO	fragmentary order
freq	frequency
FRIES	fast rope insertion/extraction system
FSB	forward support battalion
FSE	fire support element
FSMC	forward support medical company
FSO	fire support officer
ft	foot/feet
FW	fixed wing
gal	gallon

GAS	ground aided seeker
GB	gigabyte
gnd	ground
gph	gallons per hour
GPM	gallons per minute
GPS	global positioning system
GS	general support
GSAB	general support aviation battalion
GSR	ground surveillance radar
HA	holding area
hel	helicopter
HF	high frequency
HHC	headquarters and headquarters company
HICHS	helicopter internal cargo-handling system
HIRSS	hover infrared suppression system
HMMWV	high-mobility multipurpose wheeled vehicle
hosp	hospital
HQ	headquarters
hrs	hours
IBM	International Business Machine [corporation]
ICS	intercom system
IEW	intelligence and electronic warfare
IFF	identification, friend or foe [radar]
illum	illumination
IMC	instrument meteorological condition
IN	infantry
INTSUM	intelligence summary
IO	information operations
IPB	intelligence preparation of the battlefield
IPC	initial planning conference
IR	infrared
IRCM	infrared countermeasures
ISOPREP	isolation preparation
IW	information warfare
JCSAR	joint combat search and rescue
JFC	joint force commander
JPN	jam program number
JSRC	joint search and rescue center
JTF	joint task force

km	kilometer
lbs	pounds
LCU	lightweight computer unit
LH	left hand
LNO	liaison officer
LOS	line of sight
LP/OP	listening post/observation post
LRSD	long-range surveillance detachment
LT	light
LZ	landing zone
M	meter
MM	millimeter
MAC	maintenance allocation chart
maint	maintenance
MAS	main aid station
max	maximum
MB	megabyte
MBA	main battle area
MCS	maneuver control system
MEDEVAC	medical evacuation
METT-T	mission, enemy, terrain, troops available, and time
MI	military intelligence
min	minute
MLRS	multiple launch rocket system
MOP	memorandum of policy
MOPP	mission-oriented protective posture
MRE	meal, ready-to-eat
MSB	main support battalion
MSE	mobile subscriber equipment
MSEC-BBS	multiservice electronic combat-bulletin board system
MSMC	main support medical company
msn	mission
MSR	main supply route
MTF	medical treatment facility
MTI	moving target indicator
MTOE	modification table of organization and equipment
NAI	named area of interest
NCO	noncommissioned officer

NCTR	noncooperative target recognition
NEO	noncombat evacuation operation
NLT	not later than
NOD	night observation device
NOE	nap-of-the-earth
NOTAM	notice to airman
NVG	night vision goggles
OBJ	objective
OCONUS	outside continental United States
OP	observation post
OPCON	operational control
OPLAN	operation plan
OPORD	operation order
OPSEC	operations security
PA	physician's assistant/position areas
PAC	personnel and administrative center
pax	passengers
PCC	precombat checks
PCI	precombat inspections
PIR	priority intelligence requirements
PMCS	preventive maintenance checks and services
POC	point of contact
POL	petroleum, oil, and lubricants
POW	prisoner of war
PPC	performance planning card
PRF	pulse repetition frequency
PRI	pulse repetition interval
PW	pulsed wave
PZ	pickup zone
PZCO	pickup zone control officer
QRF	quick reaction force
QSTAG	Quadripartite Standardization Agreement
R	reinforce
R&S	reconnaissance and surveillance
RAM	random access memory
recon	reconnaissance
RAS	regimental aviation squadron
RCC	rescue coordination center

REDCON	readiness condition
RF	radio frequency
RFCM	radio frequency countermeasures
RFI	request for information
RH	right hand
ROE	rules of engagement
ROZ	restricted operations zone
RP	reverse planning
RSDS	radar signal detecting set
RTO	radiotelephone operator
RW	rotary wing
S1	Adjutant [US Army]
S2	Intelligence Officer [US Army]
S3	Operations and Training Officer [US Army]
S4	Supply Officer [US Army]
SAC	support aviation company
SAFE	selected area for evasion
SAM	surface-to-air missile
SAR	search and rescue
SARH	semiactive radar homing
SASO	stability and support operations
SATCOM	satellite communications
SCATMINWARN	scatterable mine warning
SEAD	suppression of enemy air defense
SEMA	special electronic mission aircraft
sep	separate
SERE	survival, evasion, resistance, and escape
SIDPERS	standard installation/division personnel system
SINCGARS	single channel ground and air radio system
SIP	standardization instructor pilot
SITEMP	situational templates
SITREP	situation report
SOI	signal operation instructions
SOP	standing operating procedure
SP	staging plan
SPINS	special instructions
SPO	support operations officer
SPT	support
SQI	skill qualification identifier
STANAG	standardization agreement
STNDS	standards

STUIII	secure telephone unit
TAC	tactical
TAC CP	tactical command post
TACON	tactical control
TARC	target acquisition and reconnaissance company
TC	training circular
TCU	tactical computer unit
TF	task force
TM	technical manual
TOC	tactical operations center
TOE	table of organization and equipment
TOF	time of flight
TOO	tactical operations officer
TOW	tube-launched, optically tracked, wire-guided
TRADOC	US Army Training and Doctrine Command
TRP	target reference point
TTP	tactics, techniques, and procedures
TVM	track-via-missile
UAV	unmanned aerial vehicle
UCMJ	Uniform Code of Military Justice
UHF	ultra high frequency
UMCP	unit maintenance collection point
UMT	unit ministry team
US	United States
USAF	United States Air Force
VHF	very high frequency
vis	visibility
WARNORD	warning order
WX	weather
xmsn	transmission
XO	executive officer
#	number



REFERENCES

SOURCES USED

These sources have been quoted, paraphrased, or referred to in the publication of this manual.

Army Regulations

AR 95-1. Army Aviation: Flight Regulations. 30 May 1990.

AR 611-112. Manual of Warrant Officer Military Occupational Specialties. 26 June 1995.

AR 525-15. (S) Software Reprogramming Policy for Target Sensing Weapon Systems (U). 1 February 1993.

AR 750-1. Army Materiel Maintenance Policy and Retail Maintenance Operations. 1 August 1994.

Field Manuals

[FM 1-100](#). Army Aviation Operations. 21 February 1997.

[FM 1-111](#). Aviation Brigades (Final Draft). May 1996.

[FM 1-112](#). Attack Helicopter Operations. 2 April 1997.

[FM 1-500](#). Army Aviation Maintenance. 27 January 1995.

[FM 7-20](#). The Infantry Battalion. 6 April 1992.

[FM 8-10-6](#). Medical Evacuation in a Theater of Operations. 31 October 1991.

FM 14-7. Finance Operations. 17 August 1994.

[FM 16-1](#). Religious Support. 26 May 1995.

[FM 20-32](#). Mine/Countermine Operations. 30 September 1992.

[FM 34-10-7](#), Quickfix Operations, 30 September 1991.

FM 34-42. Multi-Service Procedures for Electronic Warfare Operations in a Joint Environment. 1 July 1994.

[FM 63-2](#). Division Support Command, Armored, Infantry, and Mechanized Infantry Divisions. 20 May 1991.

[FM 63-20](#). Forward Support Battalion. 26 February 1990.

[FM 71-100](#). Division Operations. 28 August 1996.

FM 90-18. Multi-Service Procedures for Combat Search and Rescue. 31 May 1991.

[FM 90-4](#). Air Assault Operators. 16 March 1987.

[FM 100-5](#). Operations. 14 June 1993.

[FM 100-103](#). Army Airspace Command and Control in a Combat Zone. 7 October 1987.

[FM 101-5](#). Staff Organization and Operations. 25 May 1984.

[FM 100-10](#). Combat Service Support. 3 October 1995.

[FM 100-15](#). Corps Operations. 29 October 1996.

Department of the Army Forms

DA Form 581. Request for Issue and Turn-in of Ammunitions. August 1989.

DA Form 2028. Recommended Changes to Publications and Blank Forms. 1 February 1974

DA Form 2404. Equipment Inspection and Maintenance Worksheet. 1 April 1979.

Joint Publications

[JCS Pub 3-50.2](#). Doctrine for Joint Combat Search and Rescue. 26 January 1996.

[JCS Pub 3-56.1](#). Command Control for Joint Operations. 14 November 1994.

Technical Manuals

TM 1-1500-204-23-1. Aviation Unit Maintenance (AVUM) and Aviation Intermediate Maintenance (AVIM) Manual for General Aircraft Maintenance (General Maintenance and

Practices) Volume I. 31 July 1992.

[TM 1-1520-237-10](#). Operator's Manual for UH-60A Helicopter, UH-60L Helicopter, EH-60A Helicopter. 31 August 1994

TM 11-5895-1449-12. Operator's Manual and Aviation Unit Maintenance Manual for Communicating Central AN/ASC-15B. 1 September 1995

TM 55-1520-240-10. Operator's Manual for Army CH-47D Helicopter. 30 April 1992

Department of the Pamphlets

DA PAM 738-751. Functional Users Manual for the Army Maintenance Management System-Aviation. 15 June 1992.

Training Circulars

[TC 1-210](#). Aircrew Training Program Commander's Guide to Individual and Crew Standardization. 3 October 1995.

DOCUMENTS NEEDED

These document must be available to the intended user of this publication.

Army Regulations

AR 5-9. Intraservice Support Installation Area Coordination. 1 March 1984.

AR 25-400-2. The Modern Army Recordkeeping System (MARKS). 26 February 1993.

AR 55-4. CONUS Military Installation Materiel Outloading and Receiving Capability Report. 15 December 1984.

AR 55-60. Official Table of Distances (Continental United States, Alaska, Hawaii, Canada, Canal Zone, Central America, Mexico, and Puerto Rico). 1 December 1981.

AR 55-71. Transportation of Personal Property and Related Services. 1 June 1983.

AR 55-355. Defense Traffic Management Regulation. 31 July 1986.

AR 59-18. Management of System 463L Pallets, Nets, and Tie-Down Equipment. 25 March 1988.

AR 70-47. Engineering for Transportability. 19 August 1985.

AR 71-31. Management System for Tables of Organization and Equipment. 20 July 1989.

AR 190-11. Physical Security of Arms, Ammunition, and Explosives. 30 September 1993.

AR 220-10. Preparation for Oversea Movement of Units (POM). 15 June 1973.

[AR 220-15](#). Journals and Journal Files. 1 December 1983

AR 310-25. Dictionary of United States Army Terms. 15 October 1983.

AR 310-49. The Army Authorization Documents System (TAADS). 15 December 1980.

AR 380-5. Department of the Army Information Security Program. 25 February 1988.

AR 385-10. Army Safety Program. 23 May 1988

AR 700-15. Packaging of Materiel. 25 October 1990.

AR 740-32. Responsibilities for Technical Escort of Dangerous Materials. 5 June 1975.

AR 746-1. Packaging of Army Materiel for Shipment and Storage. 8 October 1985.

Department of the Army Forms

DA Form 1594. Daily Staff Journal or Duty Officer's Log. 1 November 1962.

DA Form 4004. Message Book M-210-B. 1 February 1977.

DA Pamphlets

DA PAM 25-30. Consolidated Index of Army Publications and Blank Forms. 1 April 197

DA PAM 746-1. Pallets and Storage Aids for Army Use. 28 October 1988.

Field Manuals

FM 1-102. Army Aviation in an NBC Environment. 30 September 1985.

FM 1-104. Tactics, Techniques, and Procedures for Forward Arming and Refueling Points. 12 September 1994.

FM 1-116. Tactics, Techniques, and Procedures for the Air Cavalry/Reconnaissance Troop. 20 February 1991.

FM 1-117. Air Reconnaissance Squadron. 30 May 1989.

FM 1-202. Environmental Flight. 23 February 1983.

FM 1-301. Aeromedical Training for Flight Personnel. 29 May 1987.

FM 1-546. Shipboard Operations. Projected Publication Date: 29 June 1997.

[FM 3-4](#). NBC Protection. 29 May 1992.

[FM 3-6](#). Field Behavior of NBC Agents (Including Smoke and Incendiaries). 3 November 1986.

[FM 3-7](#). NBC Field Handbook. 29 September 1994.

[FM 3-100](#). Chemical Operations Principles and Fundamentals. 8 May 1996.

[FM 5-33](#). Terrain Analysis. 11 July 1990.

FM 5-36. Route Reconnaissance and Classification. 10 May 1985.

[FM 6-20](#). Fire Support in the AirLand Battle. 17 May 1988.

[FM 8-9](#). NATO Handbook on the Medical Aspects of NBC Defensive Operations. 1 February 1996..

[FM 8-285](#). Treatment of Chemical Agent Casualties and Conventional Military Chemical Injuries. 22 December 1995.

[FM 10-27](#). General Supply in Theaters of Operations. 20 April 1993.

[FM 12-6](#). Personnel Doctrine. 9 September 1994.

[FM 21-11](#). First Aid for Soldiers. 27 October 1988.

[FM 34-1](#). Intelligence and Electronic Warfare Operations. 27 September 1994.

FM 34-3. Intelligence Analysis. 15 March 1990.

FM 34-40. (S)Electronic Warfare Operations(U). 9 October 1987.

[FM 34-81](#). Weather Support for Army Tactical Operations. 31 August 1989.

[FM 44-8](#). Small Unit Self-Defense Against Air Attack. 30 December 1981.

[FM 55-10](#). Movement Control in a Theater of Operations. 8 December 1992.

[FM 55-20](#). Army Rail Transport Units and Operations. 31 October 1986.

[FM 71-3](#). The Armored and Mechanized Infantry Brigade. 8 January 1996.

[FM 90-21](#). JAAT Multi-service Procedures for Joint Air Attack Team Operations. 16 October 1991.

[FM 100-15](#). Corps Operations. 29 October 1996.

[FM 100-103](#). Army Airspace Command and Control in a Combat Zone. 7 October 1987.

Technical Bulletins

TB 55-45. Certification of Military Equipment for Transport in MCA/CRAF Aircraft. 15 January 1995.

TB 55-46-1. Standard Characteristics (Dimensions, Weight, and Cube) for Transportability of Military Vehicles and Other Outsize/Overweight Equipment. 1 January 1996.

TB 55-46-2. Standard Transportability Characteristics (Dimensions, Weight, and Cube) for Military Vehicles and Equipment. 15 January 1997.

Technical Manuals

TM 3-4240-280-10. Operations Manual for Mask, Chemical-Biological: Aircraft, ABC-M24 and Accessories and Mask, Chemical-Biological, Tank, M25A1 and Accessories. 15 March 1988.

TM 38-230-1. Packaging of Materiel: Preservation (Vol I). 1 August 1982.

TM 38-230-2. Packaging of Materiel: Preservation (Vol II). 15 June 1977.

TM 55-603. Movement of Military Impediments by Commercial Carriers. 28 October 1977.

PROJECTED PUBLICATIONS

Projected publications are sources of information that are scheduled for printing but are not yet available. Upon print, they will be distributed automatically via pinpoint distribution. They may not be obtained from the US Army Publications Distribution Center, 2800 Eastern Boulevard, Baltimore, Maryland 21220-2896, until indexed in DA Pamphlet 25-30.

Field Manuals

[FM 1-111](#). Aviation Brigades. Projected Publication Date: September 1997.

FM 1-140-1. Master Gunner Handbook. Projected Publication Date: August 1997.

FM 90-36. Targeting. (Final Signature Draft dated May 1996) Project Publication Date:

July 1977

[FM 100-20](#). Stability and Support Operations. (Final draft dated April 1996) Projected Publication Date: July 1997.

FM 100-40. Tactics. (Initial draft dated 15 March 1996) Projected Publication Date: July 1997.

[FM 101-5-1](#). Operational Terms and Graphics. (Draft Version dated 15 November 1996) Projected Publication Date: August 1997.



FM 1-113
12 SEPTEMBER 1997

By Order of the Secretary of the Army:

Official:

JOEL B. HUDSON
*Administrative Assistant to the
Secretary of the Army*
03803

DENNIS J. REIMER
General, United States Army
Chief of Staff

DISTRIBUTION:

Active Army, Army National Guard, and U.S. Army Reserve: To be distributed in accordance with the initial distribution number 110713, requirements for FM 1-113.

*U.S. Government Printing Office: 1997 - 527-027/60100

