



QB-180/300

Oil Burners – Series 2

For Weil-McLain GO, 66 & 68 Boilers

Burner Manual



Patent 5,961-316

Read all instructions before installing

WARNING

This manual must only be used by a qualified heating installer/service technician. Failure to comply could result in severe personal injury, death or substantial property damage.

Installer Leave all documentation with burner for future reference.

User Burner must be installed and annually serviced by a qualified installer/service technician.



IMPORTANT! – Read this page first

Hazard definitions

The following defined terms are used throughout this manual to bring attention to the presence of hazards of various risk levels or to important information concerning the life of the product.

<p>DANGER Indicates presence of hazards that will cause severe personal injury, death or substantial property damage.</p>	<p>CAUTION Indicates presence of hazards that will or can cause minor personal injury or property damage.</p>
<p>WARNING Indicates presence of hazards that can cause severe personal injury, death or substantial property damage.</p>	<p>NOTICE Indicates special instructions on installation, operation or maintenance that are important but not related to personal injury or property damage.</p>

- WARNING** Read and follow instructions below to install or service the burner to reduce risk of severe personal injury, death or substantial property damage.
- Appliance must be connected to a flue with sufficient draft at all times to assure proper operation.
 - Do not use crankcase drainings or any oil containing gasoline as it is more combustible than No. 1 or No. 2 fuel oil.
 - Do not attempt to start burner when excess oil has accumulated in combustion chamber, when boiler is full of vapor, or when combustion chamber is very hot.
 - Always keep manual fuel supply valve shut off if burner is shut down for an extended period of time.
 - Do not start burner unless flue collector hood, jacket cap, flue cap and burner mounting door are secured in place.
 - Never burn garbage or paper in the appliance.
 - Never leave combustible material around appliance.



Contents

	Hazard definitions	2
	Table of contents	3
1	Pre-installation considerations	4
2	Burner installation	5
3	Fuel pumps and oil lines	8
4	Wiring, operation and service	11
5	Troubleshooting	12
6	Parts list	14
	Weil-McLain Limited Warranty	Back cover



1

Pre-installation considerations

Codes and standards

- Install burner in accordance with NFPA 31, Standard for Oil-Burning Equipment and all local codes and regulations of authorities having jurisdiction. In Canada, refer to CSA B139, Installation Code for Oil-Burning Equipment. Regulations of these authorities take precedence over instructions in this manual.
- All wiring must comply with National Electrical Code and local ordinances; in Canada, CSA C22.1 Canadian Electrical Code Part One and any local codes. Refer to wiring diagram in **Control Supplement** supplied with burner.
- Underwriters Laboratories has certified this burner to comply with ANSI Standard 296.6 and has listed it for use with No. 1 or No. 2 fuel oil as specified in ASTM D396.

Chimney or vent

WARNING

Inspect existing chimney or vent before installing new burner. Failure to do the following will cause severe personal injury or death.

- Clean chimney, including removal of blockage.
- Repair or replace damaged pipe or liner.
- Repair mortar and joints.

Set the over-fire draft to the appliance manufacturer's recommended setting if available, or to -0.01" to -0.02" water column. Install barometric control in breeching, per control manufacturer's instructions, when excess draft needs to be relieved or to comply with applicable codes and regulations. Use draft gauge to adjust proper opening.

Combustion and ventilation air openings

See appliance manual and **NFPA 31, Standard for Oil-Burning Equipment** for details. For recommended practice in Canada, refer to **CSA Standard B139**.

WARNING

Adequate combustion and ventilation air must be provided to assure proper combustion and reduce risk of flue gas leakage and carbon monoxide emissions, leading to severe personal injury or death.

When the boiler is installed in a confined space (volume of space less than 50 cubic feet per 1,000 Btuh input of all appliances in space), **two** permanent openings must be provided:

- One near the top of the enclosure
- One near the bottom.
- Each opening must have a free area of not less than one (1) square inch per 1,000 Btuh (140 square inch per gph), of the total input rating of all the appliances in the space.

When building is of unusually tight construction, has a kitchen ventilating system, exhaust fans, clothes dryer or vented fireplaces, it may be necessary to duct outside air directly to the burner in order to support clean combustion. Weil-McLain QB-A1 Outside Air Kit, part number 644-500-056, provides outside air directly to the burner.

NOTICE

- If QB-180 or QB-300 Oil Burner is received separately for field installation, proceed to page 5, **Burner Installation**.
- If QB-180 or QB-300 Oil Burner is received installed on the boiler, proceed directly to page 8, **Fuel Pumps and Oil Lines**.



2

Burner installation

Figure 1 Burner components

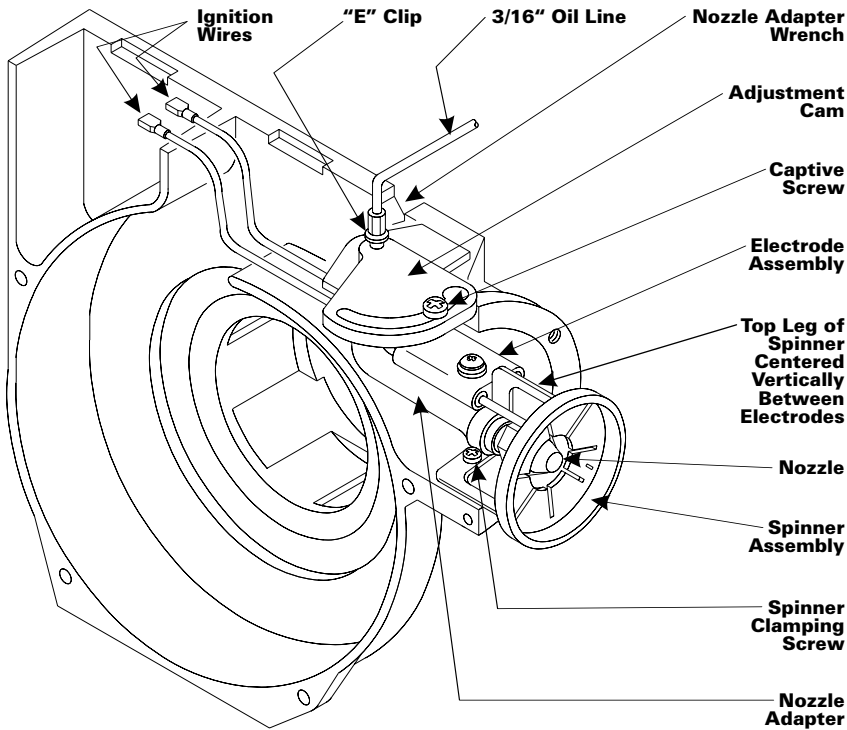

GUN ASSEMBLY Includes:

- Adjustment Cam**
- Electrode Assembly**
- Spinner Assembly**
- Nozzle**
- Nozzle Adapter**
- Oil Line**
- Ignition Wires**

06502

Mounting burner

1. Remove burner from packing box.
2. Detach and save plastic bag with instructions and bypass plug from fuel pump.
3. Install or verify correct nozzle as applicable:
 - a. Loosen, but do not remove, screw holding housing cover plate in place. Pull ignitor back and up to swing open cover plate.
 - b. Disconnect oil line from solenoid valve.
 - c. Disconnect ignition wires from ignitor. Loosen, but do not remove, captive screw securing adjustment cam in place. Turn adjustment cam so that the larger end of the slot aligns with the captive screw. Pull gun assembly back and up to remove.
 - d. Loosen clamping screw on spinner assembly and slide assembly off nozzle adapter.
 - e. See **Table 1** on page 6 for proper nozzle size. Make sure nozzle is tight in adapter (110 in-lbs nominal). Nozzle adapter wrench in burner housing can hold nozzle adapter while you tighten nozzle.
 - f. Check electrode settings per **Figure 2**.
 - g. Replace spinner assembly on nozzle adapter. Top leg of spinner must align vertically back against the shoulder on adapter. Tighten clamping screw.

Figure 2 Electrode settings

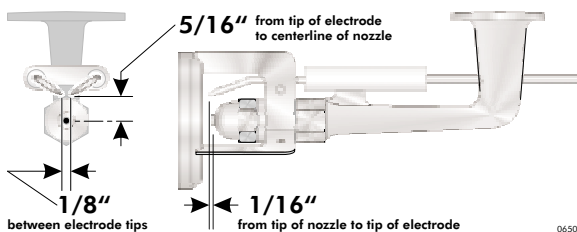

WARNING

Fuel pump is factory set at **140** psig (QB-300) or **150** psig (QB-180). Use of a nozzle selected for 100 psig pressure could result in severe personal injury, death or substantial property damage.



2

Burner installation continued

Table 1 Burner nozzle selection **CAUTION** Use only the nozzles specified.

Boiler model	QB-180 burner nozzle size (Pump pressure is 150 psig)				Pump pressure (psig)	Cam setting	Air band setting
	Preferred	Alternates					
	Delavan	Hago	Danfoss	Steinen			
GO-2	0.65 70° A	0.65 70° B	0.65 70° AS	0.65 70° S	150	0.70/0.95	3.25
GO-3	0.85 70° A	0.85 70° B	0.85 70° AS	0.85 70° S	150	0.70/0.95	5.25
GO-4	1.00 70° B	1.00 70° B	1.00 70° AS	1.00 70° S	150	1.20	5.50
GO-5	1.25 60° B	1.25 45° B	1.25 60° AS	1.25 70° S	150	1.45	6.25
GO-6	1.50 45° B	1.50 45° B	-	1.50 45° S	150	1.75	6.75
268 *	0.65 70° A	0.65 70° H	-	0.65 70° H	150	0.70/0.95	3.00
368	0.85 70° A	-	0.85 70° AH	-	150	0.70/0.95	5.00
468	1.10 70° A	1.10 70° ES	1.10 70° AS	1.10 80° S	150	1.20	5.25
568	1.25 60° B	1.25 70° B	1.25 60° AS	-	150	1.45	6.00
668	1.50 45° B	1.50 60° B or 1.50 45° ES	1.50 60° AS	1.50 60° S	150	1.75	6.50
266 *	0.65 70° A	0.65 70° H	-	0.65 70° H	150	0.70/0.95	3.00
366	0.85 70° A	0.85 70° B	0.85 70° AS	-	150	0.70/0.95	5.00
466	1.10 70° A	1.10 60° H	1.10 70° AH	1.10 70° H	150	1.20	5.25
566	1.25 60° B	1.25 70° B	1.25 60° AS	-	150	1.45	6.00
666	1.50 45° B	1.50 60° B or 1.50 45° ES	1.50 60° AS	1.50 60° S	150	1.75	6.50

* Install baffle clip per instructions packed with kit.
 1. Nozzle: Tighten to 110 in/lbs.
 2. Nozzle types: A, AH, H = hollow; SS = semi-solid B, ES, R, S, AS = solid
 3. Suggested settings are for set-up with listed nozzle sizes only. Final adjustments must be made with combustion test equipment and should provide zero smoke with proper CO₂.
 4. For I=B=R boiler capacity, refer to individual boiler manual.

Boiler model	QB-300 burner nozzle size (Pump pressure is 140 psig)			Pump pressure (psig)	Cam setting	Air band setting
	Preferred	Alternates				
	Hago	Delavan	Steinen			
GO-6	1.50 60° B or 1.50 45° B	1.50 45° B	1.50 60° S	140	1.75	2.25
GO-7	1.75 60° B or 1.75 45° B	1.75 60° B	1.75 70° S	140	2.00	3.75
GO-8	2.00 60° P or 2.00 45° P	2.00 70° B	2.00 70° S	140	2.30	5.75
GO-9	2.25 60° P or 2.25 45° P	2.25 60° B or 2.25 45° B	2.25 60° S	140	2.55	5.25
668	1.50 60° B or 1.50 45° B	1.50 45° B	1.50 60° S	140	1.75	2.25
768	1.75 60° B or 1.75 45° B	1.75 60° B	1.75 70° S	140	2.00	3.75
868	2.00 45° P	2.00 70° B	2.00 70° S	140	2.30	5.75
968	2.25 60° P	2.25 60° B	2.25 60° S	140	2.55	5.25
666	1.50 60° B or 1.50 45° B	1.50 45° B	1.50 60° S	140	1.75	2.25
766	1.75 60° B or 1.75 45° B	1.75 60° B	1.75 70° S	140	2.00	3.75
866	2.00 45° P	2.00 70° B	2.00 70° S	140	2.30	5.75
966	2.25 60° P	2.25 60° B	2.25 60° S	140	2.55	5.25

1. Suggested settings are for set-up with listed nozzle sizes only. Final adjustments must be made with combustion test equipment and should provide zero smoke with proper CO₂.
 2. For I=B=R boiler capacity, refer to individual boiler manual.
 3. Nozzle types: B, ES, P, S = solid
 4. Nozzle: Tighten to 110 in/lbs.



Burner settings

4. Reinstall gun assembly:
 - a. Insert gun assembly into burner – do not force it. The gun assembly must be lifted and guided into air cone at end of air tube.
 - b. Turn adjustment cam so that the larger end of the slot drops over the captive screw.
 - c. Position gun assembly by rotating adjustment cam (**Figure 3**) to correct setting. See **Table 1**, page 6, for correct adjustment cam setting. Tighten captive screw to lock adjustment cam in place.
 - d. Connect oil line to solenoid valve.
 - e. Connect ignition wires to ignitor.
 - f. Swing cover plate closed and push forward to engage locking pins.
 - g. Tighten screw holding housing cover plate in place.
5. Mount burner to boiler with gasket supplied.
6. Verify attenuating air band setting. See **Table 1**, page 6, and **Figure 4**.

Figure 3 Adjustment cam setting

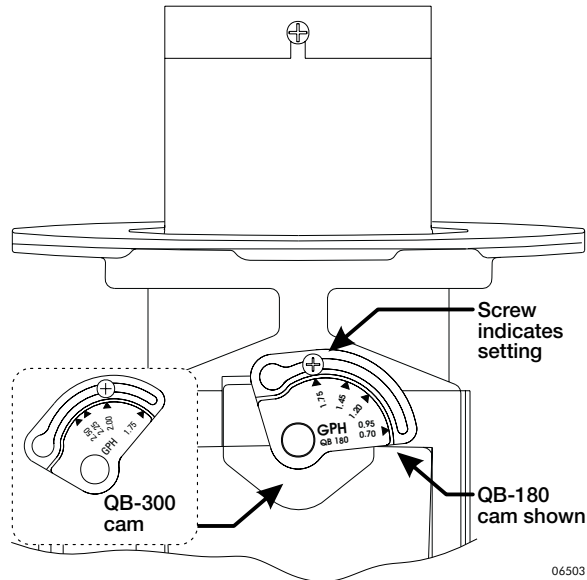

06503

Figure 4 Attenuating air band setting

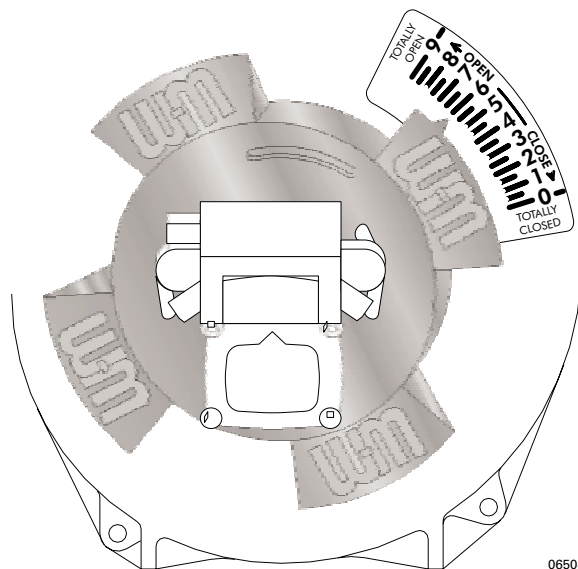

06504

WARNING

Starting settings in **Table 1** are for setup only. Final adjustments must be made with combustion test equipment and should provide zero smoke with proper CO₂. See **Final adjustments** on page 11.

Adjust the air band setting first. If adjustments of the air band do not result in clean combustion, then adjust the cam setting. Increase the setting to increase air. Decrease the setting to reduce air. Cam adjustments should be minor only.



3

Fuel pumps and oil lines

General

All installations must comply with national or local codes and ordinances.

WARNING

Oil line must be piped properly to avoid risk of serious personal injury, death or substantial property damage. Follow these recommendations:

- When installing oil lines, use continuous runs of heavy-wall copper tubing.
- Be sure all connections are airtight. Flared fittings are recommended. Do not use compression fittings. Do not use Teflon tape.
- Use an oil filter of adequate size for all installations. Install filter inside building between tank shutoff valve and burner. For easy servicing, locate shutoff valve and filter near burner.
- Long or oversized inlet lines may require the pump to operate dry during initial bleeding period. In such cases, assist priming by injecting fuel oil into pump gasket.
- Never exceed 3 psi pressure to inlet side of pump. Pressure over 3 psi may damage shaft seal and allow it to leak oil.

Solenoid valve

Solenoid valve supplied in nozzle line is a non-delay valve and provides instant oil supply shutoff to nozzle.

Vacuum gauge

Vacuum gauge may be installed in either of the 1/4" inlet ports. Vacuum is total of all pressure drops in system from tank to pump inlet.

Oil pump pressure

To check operating pressure, use gauge port or nozzle

port. Do not use easy flow air bleed valve. It contains higher pressure than operating pressure.

Setting pump pressure with gauge in easy flow air bleed valve will result in wrong operating pressure.

Average cutoff pressure is 120 psig. Check cutoff pressure by installing pressure gauge in nozzle port of fuel pump. Run burner for short time. Shut off burner. Gauge shows cutoff pressure.

Figure 5 Fuel pump — Typical

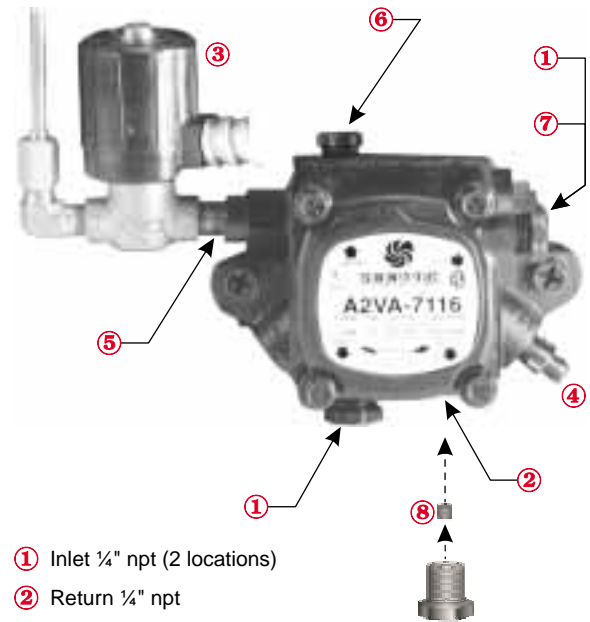

- ① Inlet 1/4" npt (2 locations)
- ② Return 1/4" npt
- ③ Solenoid valve
- ④ Easy flow air bleed valve
- ⑤ Nozzle port 1/8" npt (read operating pressure)
- ⑥ Pressure gauge port 1/8" npt (read operating pressure)
- ⑦ Regulating pressure (behind inlet)
- ⑧ 1/16" bypass plug — insert for **two-pipe systems ONLY** (use 5/32" allen wrench)

06505



One-pipe oil systems (Figure 6)

Use one-pipe oil piping only when:

- the fuel is gravity fed — or —
- the fuel must be lifted **no more than 8 feet**. See **Figure 6**. (If the fuel lift is greater than 8 feet use two-pipe fuel piping — **Figure 7** on page 10.)
- fuel suction line **vacuum is less than 6" Hg** for either a single-stage or two-stage burner fuel pump.

Burner fuel pump bypass plug must not be used with one-pipe installations.

One-pipe installations must be absolutely air tight to prevent leaks or loss of prime. Bleed line and fuel pump completely. Bleed for 15 seconds after last air bubble is seen from easy flow air bleed valve to be certain lines are air free. When bleeding oil pumps on burners equipped with lockout-type controls, you may have to cycle the burner several times to complete purging.

Figure 6 One-pipe oil system, typical

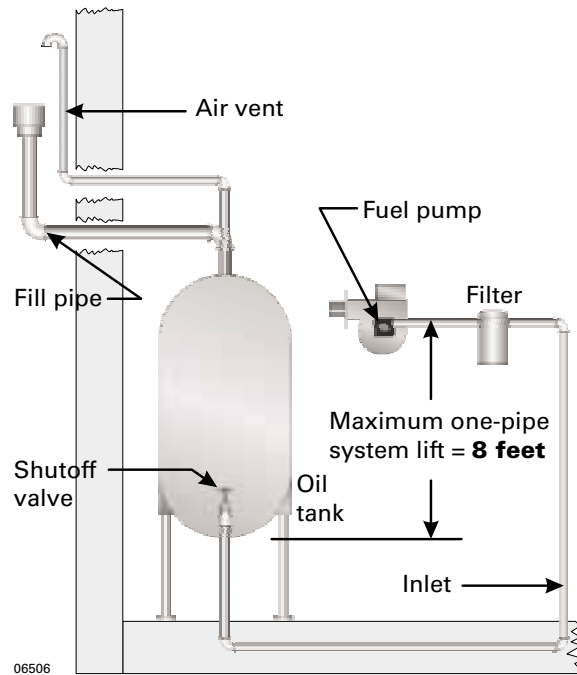



3

Fuel pumps and oil lines continued

Two-pipe oil systems (Figure 7)

Use two-pipe installations when fuel must be lifted greater than 8 feet.

Burner fuel pump — A single-stage pump is limited to a fuel lift height of no more than 10 feet. For greater lifts install a two-stage pump on the burner.

Fuel suction line vacuum must not exceed 12" Hg for a single-stage pump or 17" for a two-stage pump.

Bypass plug must be used with two-pipe installations. Remove plug from plastic bag attached to fuel pump. Remove 1/4" plug from return port. Insert bypass plug. Attach return and inlet lines.

Always terminate return line as shown in **Figure 7**.

To determine two-pipe maximum line lengths, use **Table 2**, page 10.

Figure 7 Two-pipe oil system, typical

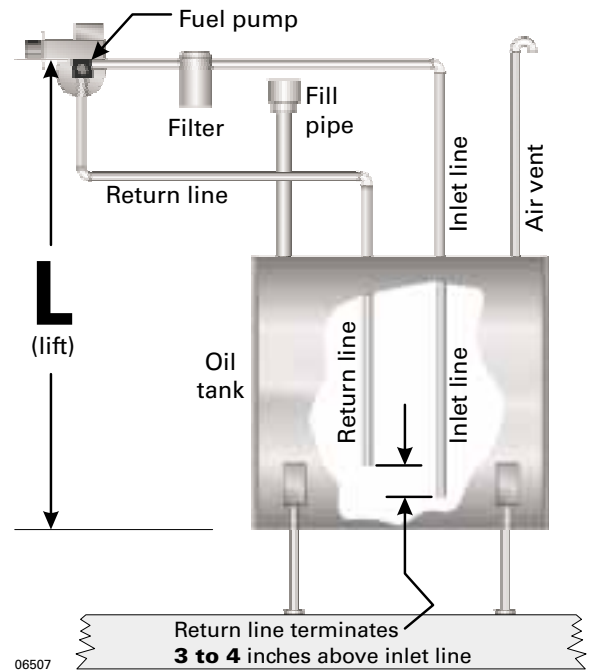

Table 2 Two pipe oil system maximum oil line lengths (feet)

Lift "L"	Single-stage oil pump		Two-stage oil pump	
	3/8" O.D.	1/2" O.D.	3/8" O.D.	1/2" O.D.
0	84	100	93	100
2	73	100	85	100
4	63	100	77	100
6	52	100	69	100
8	42	100	60	100
10	31	100	52	100
12	Not recommended — use two-stage pump		44	100
14			36	100
16			27	93
18			--	65

Note: Line lengths include total of vertical and horizontal lengths.



4

Wiring, operation and service

Wiring

Wire the burner (and boiler) following instructions in the burner **Control Supplement** and the **Boiler Manual**.

Start-up

Read the sequence of operation and start-up procedures in the burner **Control Supplement**.

Final Adjustments

WARNING

You must use **test instruments** to properly start, check and adjust burner. Failure to do so could result in severe personal injury, death or substantial property damage.

1. Make sure combustion and ventilation air supply is sufficient for normal appliance operation. Close windows and doors in appliance area to simulate normal job condition. Start boiler and allow for a 10-minute warm up.
2. Check for $-.01''$ to $-.02''$ W.C. draft in combustion chamber. Adjust barometric damper as necessary.
3. Check for 0 smoke.
4. Check for CO₂ between 11% and 12 ½%.
 - To **increase** CO₂, **close** attenuating air band setting.
 - To **decrease** CO₂, **open** attenuating air band setting.
5. Check CO₂, smoke and draft levels again.
6. Start and stop unit several times.
7. Check operation of limits, thermostats and timing of combustion control.
8. Check for oil leaks.
9. **Recheck all installations** after one to two weeks of operation.

Service

WARNING

Electrical shock hazard. Failure to shut off electrical supply before servicing can cause severe personal injury, death or substantial property damage.

1. See **Boiler Service/Maintenance Guide** for details of annual service call, including cleaning boiler flueways.
2. Oil blower motor (if required). Refer to motor name plate/specifications label for any instructions.
3. Replace oil filter cartridge once a year to prevent fuel oil contamination from plugging fuel pump and nozzle.
4. Replace nozzle once a year before start up of heating season. Always use proper nozzle. See **Table 1** on page 6.
5. Check electrode settings once a year. See page 5.
6. Clean fan and blower housing regularly to keep free of dirt and lint.
7. Check and adjust burner according to **Start-up** procedures in **Control Supplement** after each servicing.
8. Contact your Weil-McLain distributor for all burner parts that need replacement.

When servicing a NO HEAT call:

Check each item below, making sure to complete each check before going to the next one.

- Thermostat(s).
- Main fuse and power supply.
- Service switch on boiler.
- Oil level in oil tank.
- Oil valves.
- Limit control.
- Primary control.
- Motor.

When all of the above checks are made, then refer to **Troubleshooting** on pages 12 and 13.



5

Troubleshooting

If burner does not start

The relay in the primary control may not be pulling in – Check for:

- Broken wires
- Defective thermostat
- Dirty thermostat contacts
- Defective primary control

The motor is out on thermal overload – Check for:

- Seized motor bearing
- Seized fuel pump
- Fan locked against housing
- Start winding burned out
- Defective starter switch
- Defective wiring

If burner starts, but there is no flame

Primary control may have pre-purge – Check Control Supplement.

There may be insufficient oil flow – Check for:

- Defective fuel pump
- Air leaks in suction line
- Pump strainer clogged
- Clogged or dirty nozzle
- Defective solenoid valve
- Clogged fuel filter
- Loose coupling

There is no ignition spark – Check for:

- Defective/loose wiring connections at primary control or electrode assembly
- Defective porcelain insulator on electrode assembly
- Incorrect electrode settings
- Defective ignitor

There is oil and spark, but no flame – Check for:

- Loose, dirty or defective nozzle
- Improper oil conditions
- Low pump pressure
- Improper spinner position. To verify position, see page 5, step 3g.
- Excess air/high draft
- Incorrect electrode settings

If burner starts and has flame, but flame goes out

Primary control will shut off flame – Check for:

- Dirty cad cell
- Defective primary control
- View of fire obstructed, so that cad cell cannot see flame
- Loss of oil prime
- Defective cad cell



If burner starts and has a smoky flame

- Check for:**
- Insufficient combustion air
 - Improper mixing of oil and air
 - Insufficient draft
 - Flame impingement on target wall or crown sheet of boiler
 - Nozzle afterdrip due to faulty solenoid or cutoff valve

If you hear mechanical noise from the burner

- Check for:**
- Loose fan
 - Air in oil line
 - Defective pump gears
 - Obstructed suction line
 - Defective motor bearings
 - Pump and motor shaft misaligned
 - Defective ignitor
 - Defective primary control

If you hear combustion noise

- Check for:**
- Insufficient draft in breeching or overfire
 - Improper mixing of oil and air
 - Incorrect attenuating air band setting
 - Incorrect adjustment cam setting
 - Loose or dirty fan

If there is puffback from burner

- Check for:**
- Delayed ignition
 - Nozzle afterdrip due to poor cutoff
 - Excessive draft
 - Incorrect attenuating air band setting

If there is nozzle drip

- Check for:**
- Air in supply line from oil tank to fuel pump
 - High vacuum
 - Hot nozzle or gun assembly due to improper draft, misadjusted burner or blocked flueways in boiler



6

Parts list

Item Number	Description	Weil-McLain Part Number	
		QB-180	QB-300
1	Motor with flange, 120 V.A.C., 1/7 HP, 3450 RPM	643-900-050	
2	Blower wheel	643-900-025	
3	Burner coupling 3 1/4" Length	643-900-105	
4	Air tube gasket	643-900-095	
5	Air tube	644-200-042	644-200-046
5a	Air cone	644-200-050	644-200-051
6	Flange gasket	643-900-100	
7	Burner plug — GO boiler series only	643-900-020	
8	Attenuating air band	643-900-030	643-900-305
9	Fuel pump — Suntec, A2VA-7116-7, single-stage	643-900-060	
Not shown	Fuel pump — Suntec, B2VA-8216, two-stage	643-900-315	
10	Solenoid valve, Combu 50010 E7-LUS/115 volt, no delay opening	643-900-065	
Not shown	Solenoid coil replacement kit	643-900-008	
11	Spinner assembly, 12 vane	643-900-110	643-900-310
12	Nozzle adapter kit	643-900-005	
13	Electrode assembly kit	643-900-010	
14	Adjustment cam kit	643-900-325	643-900-326
15	Screw, captive, 8-32 x 3/8" (12 per bag)	643-900-085	
16	Wire assembly, transformer to electrode assembly	643-900-080	
17	Oil line 3/16" diameter with fittings	643-900-115	
18	Solid state ignitor kit, including adapter plate and hardware Transformer PRI-120 V.A.C., secondary, 10,000 @ 23 ma.	643-900-318	643-900-055
19	Cover plate kit	643-900-015	
20	Cad cell	643-900-070	
21	Primary control — R8184G, 1336 with T-T terminals	643-900-075	
Not shown	Primary control — 50200-02 with T-T and alarm contacts	643-900-319	
Not shown	Primary control — 60200-02 with T-T and alarm contacts, with prepurge and postpurge	643-900-317	
22	"E" clip, oil line to cam 3/8" shaft diameter (12 per bag)	643-700-218	
23	Mounting flange	644-700-201	
Not shown	Baffle clip kit — 266 or 268 boiler sizes only	643-900-006	--
Not shown	Burner head protector	643-900-007	
Not shown	Outside Air Kit QB-A1	643-900-056	

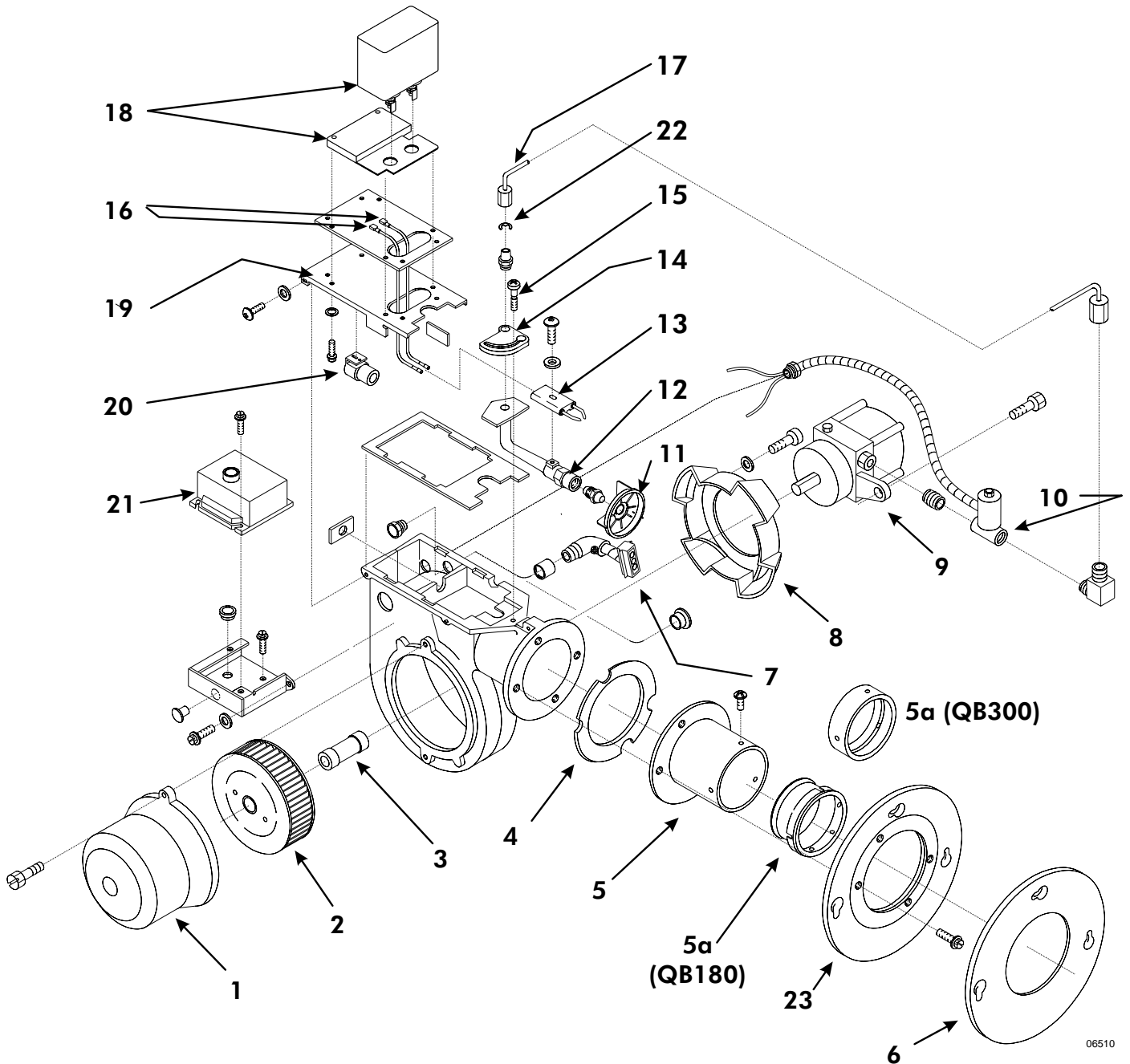

Weil-McLain Limited Warranty for QB-180 and QB-300 Burners

RESIDENTIAL OIL-FIRED BURNERS

3-Year Limited Warranty

Weil-McLain warrants that its residential oil-fired burners are free from defects in material and workmanship for three years from the date of installation. If any parts are found to be defective in manufacture, Weil-McLain will provide replacement of such defective parts with the following exceptions:

- nozzles
- cad cell

The provisions of this warranty for the above parts are limited to 12 months from the date of installation or 18 months from the date of manufacture, whichever date occurs first.

This warranty does not cover:

1. Workmanship of any installer of Weil-McLain's residential oil-fired burners. In addition, this warranty does not assume any liability of any nature for unsatisfactory performance caused by improper installation.
2. Filters, strainers or any other routine maintenance part as supplied through the contractor.
3. Any costs for labor for removal and reinstallation of the alleged defective part, transportation to Weil-McLain, if necessary, and any other materials necessary to perform the exchange.
4. Unsatisfactory performance or damage caused by improper burner adjustments, control settings, care or maintenance.
5. Burners operated with combustion air contaminated externally by chemical vapors or with improper fuel additives.

This warranty extends only to the first retail purchaser of the burner and only to a burner that has not been moved from its original installation site.

THE WARRANTY DESCRIBED ABOVE IS IN LIEU OF ALL OTHER WARRANTIES, EXPRESS OR IMPLIED, INCLUDING BUT NOT LIMITED TO ANY IMPLIED WARRANTIES OF FITNESS FOR A PARTICULAR PURPOSE AND MERCHANTABILITY. WEIL-McLAIN EXPRESSLY DISCLAIMS AND EXCLUDES ANY LIABILITY FOR CONSEQUENTIAL, INCIDENTAL, INDIRECT OR PUNITIVE DAMAGES FOR BREACH OF ANY EXPRESS OR IMPLIED WARRANTY.

For prompt warranty claims, notify the installer who, in turn, will notify the Weil-McLain distributor from whom he purchased the burner. If this action does not result in warranty service, contact Weil-McLain Consumer Relations Department, 500 Blaine Street, Michigan City, Indiana 46360-2388, with details in support of the warranty claim. Alleged defective part or parts must be returned through trade channels in accordance with the Weil-McLain procedure currently in force for handling returned goods for the purpose of inspection to determine cause of failure. Weil-McLain will furnish new part(s) to an authorized Weil-McLain distributor who, in turn, will furnish the new part(s) to the heating contractor who installed the burner. If you have any questions about the coverage of this warranty, contact Weil-McLain at the address above.



WEIL-McLAIN
A United Dominion Company

Weil-McLain
500 Blaine Street
Michigan City, IN 46360-2388
<http://www.weil-mclain.com>