

INSTALLATION GUIDE

DS4+

FORD6



This product is intended for installation by a professional installer only! Attempts to install this product by a person other than a trained professional may result in severe damage to a vehicle's electrical system and components.

2017-06-20

DIRECTED®

Contents

Warning! Safety first	3
Introduction	4
Pre-installation and application warnings	4
Vehicle application guide	5
Wiring connections	6
Main harness (H1), 12-pin black connector	6
Relay harness (H2), 10-pin white connector	6
Data harness (H3), 8-pin white connector	6
Analog input/output harness (H4), 22-pin white connector	7
RF Port harness (H5), 2-pin white connector	7
D2D harness (H6), 4-pin white (1) and black (2) connectors	7
Temperature sensor harness (H7), 2-pin black connector	7
Installation (wiring diagrams, fuse selection & vehicle wiring reference charts)	8
Type 1 - with T-Harness (THFON1)	8
Type 1	9
Type 2 - with T-Harness (THFON1)	21
Type 2	22
Key2GO	25
Understanding the difference between a Ford 80 & 40 bit	25
What does it mean?	25
How do I differentiate between the 40 & 80 bit?	25
Configuring the system	26
Important!	26
Vehicles equipped with a manual transmission	26
RF Systems	26
8504D Combo Sensor	26
When used in conjunction with SmartStart	26
D2D port configuration	27
Module programming - Using 2 Keys	28
Module programming - 1-Key programming using Key2GO	29
LED diagnostics and troubleshooting	30
Soft reset	32
Hard reset	32
Learning the Tach (not needed with Virtual Tach)	33
Initializing Virtual Tach (not needed with hardwired or data tach applications)	33
Limited lifetime consumer warranty	34
Quick Reference Guide	35

Warning! Safety first

 The following safety warnings must be observed at all times:

- Due to the complexity of this system, installation of this product must only be performed by an authorized Directed dealer.
- When properly installed, this system can start the vehicle via a command signal from the remote control. Therefore, never operate the system in an area that does not have adequate ventilation.

The following precautions are the sole responsibility of the user; however, authorized Directed dealers should:

- Never use a test light or logic probe when installing this unit. Always use a multimeter.
- Never operate the system in an enclosed or partially enclosed area without ventilation (such as a garage).
- When parking in an enclosed or partially enclosed area or when having the vehicle serviced, the remote start system must be disabled using the installed toggle switch. It is the user's sole responsibility to properly handle and keep out of reach from children all remote controls to assure that the system does not unintentionally remote start the vehicle.
- **USER MUST INSTALL A CARBON MONOXIDE DETECTOR IN OR ABOUT THE LIVING AREA ADJACENT TO THE VEHICLE. ALL DOORS LEADING FROM ADJACENT LIVING AREAS TO THE ENCLOSED OR PARTIALLY ENCLOSED VEHICLE STORAGE AREA MUST REMAIN CLOSED AT ALL TIMES.**

Use of this product in a manner contrary to its intended mode of operation may result in property damage, personal injury, or death. Except when performing the Safety Check outlined in this installation guide, (1) Never remotely start the vehicle with the vehicle in gear, and (2) Never remotely start the vehicle with the keys in the ignition. The user is responsible for having the neutral safety feature of the vehicle periodically checked, wherein the vehicle must not remotely start while the car is in gear. This testing should be performed by an authorized Directed dealer in accordance with the Safety Check outlined in this product installation guide. If the vehicle starts in gear, cease remote start operation immediately and consult with the user to fix the problem immediately.

OPERATION OF THE REMOTE START MODULE IF THE VEHICLE STARTS IN GEAR IS CONTRARY TO ITS INTENDED MODE OF OPERATION. OPERATING THE REMOTE START SYSTEM UNDER THESE CONDITIONS MAY RESULT IN PROPERTY DAMAGE OR PERSONAL INJURY. IMMEDIATELY CEASE THE USE OF THE UNIT AND REPAIR OR DISCONNECT THE INSTALLED REMOTE START MODULE. DIRECTED WILL NOT BE HELD RESPONSIBLE OR PAY FOR INSTALLATION OR REINSTALLATION COSTS.

Remote starters for manual transmission pose significant risks if not properly installed and operated. When testing to ensure the installation is working properly, only remote start the vehicle in neutral gear, on a flat surface and with a functional, fully engaged parking brake. Do not allow anyone to stand in front of or behind the vehicle.

This product should not be installed in any convertible vehicles, soft or hard top with a manual transmission. Installation in such vehicles may pose certain risk.

Introduction

The FORD6 firmware for DS4+ is compatible with specific Ford and Lincoln vehicles. It is a complete solution for remote start, security (when security features are enabled), bypass, and features built in Bluetooth 4.0 allowing you to configure and control your system. This guide provides information on the installation of the module using FORD6. Please refer to the DirectLink application or www.directechs.com for more information about which configuration is best for your application.

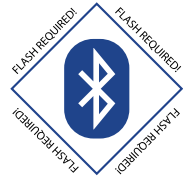

Warning! This module is designed to be configured using the DirectLink application for mobile devices, however it can also be configured using the web tool located at www.directechs.com. To download the DirectLink mobile application, please visit the Google Play or Apple store.

Pre-installation and application warnings

Start here

Firmware notes: This section highlights important information for this specific firmware and will assist in pricing accordingly, as well as bringing awareness to any operational or vehicle limitations.

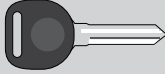
T-Harness compatible 	Yes <input checked="" type="checkbox"/> - THFON1		Keys required for programming 2	Keys required for operation 0
--	---	---	--	--

- The optional Plug & Play **THFON1** T-Harness is sold separately.
- The OBDII Diagnostic Connector features will remain the same even when the T-Harness is installed.
- Key2GO is required if only one key is available. You can program the interface without the need for Key2GO if two keys are present.
- Keys required to program:
 - 80-Bit Encryption transponder: Requires two (2) keys for programming. Key2GO is NOT compatible.
 - 40-Bit Encryption transponder: Programming can be completed with two (2) keys or with one (1) key if using Key2GO. (See "Understanding the difference between a Ford 80 & 40 bit" on page 25 for more information)
- Unless specified otherwise, all connectors are displayed from the wire side, with the exception of the OBDII diagnostic connector.
- It is important to check that the fuses are positioned correctly in the module. Refer to the "Fuse selection" section following each installation type for more information.
- Refer to the "Vehicle wiring reference chart" following each installation type.

General notes: This section highlights important information for this specific firmware.

- [1] The installation of an aftermarket hood pin is **ONLY** required on vehicles that are **NOT** equipped with a factory hood pin.
- [2] The siren is **ONLY** required when enabling the security features during module flashing.
- [3] Only required if OEM alarm equipped.
- [4] Ford Expedition & Lincoln Navigator are **NOT** compatible with optional T-Harness THFON1.

Additional parts required (maximum required):

 1 x 6A Diodes	 1 x Relay	 0 x Resistor	 0 x Fuse
--	--	--	---

Vehicle application guide

The following table lists the vehicles and features which are compatible with this product. The number assigned to each year allows you to determine which installation type should be used for your vehicle.

Vehicles	2016	2015	2014	2013	2012	2011	2010	2009	2008	PK-Immobilizer Bypass-Data No Key Req'd	DL-Arm Factory Security	DL-Disarm Factory Security	DL-Door Lock Control	DL-Door Unlock	DL-Trunk / Hatch Release	FOB-Control of aftermarket alarm with OEM remote	Key2GO	RS-3x LOCK START (Start control using OEM Remote)	RS-3x LOCK STOP (Stop control using OEM Remote)	RS-RAP Shut Down (Retained ACC Power)	RS-SmartStart	RS-Tach / RPM Output	SS-Entry Monitoring ALL Door Pins	SS-Entry Monitoring Driver Door Pin	SS-Entry Monitoring Hood Pin	SS-Entry Monitoring Trunk/Hatch Pin	ST-Brake Status (foot brake)	ST-Door Locks Status	ST-E-Brake Status
Ford																													
Edge (SA Key)			2	2	2	2				•	•	•	•	•	•	•	•	•	•	•	•	•	•	•	•	•	•	•	•
Escape					1	1	1	1	1	•	•	•	•	•	•	•	•	•	•	•	•	•	•	•	•	•	•	•	•
Escape Hybrid					1	1	1	1	1	•	•	•	•	•	•	•	•	•	•	•	•	•	•	•	•	•	•	•	•
E-Series (SA Key)			1							•	•	•	•	•	•	•	•	•	•	•	•	•	•	•	•	•	•	•	•
Expedition	1	1								•	•	•	•	•	•	•	•	•	•	•	•	•	•	•	•	•	•	•	•
Expedition (SA Key) 4			1	1	1	1				•	•	•	•	•	•	•	•	•	•	•	•	•	•	•	•	•	•	•	•
Explorer (SA Key)	2	2	2	2	2	2				•	•	•	•	•	•	•	•	•	•	•	•	•	•	•	•	•	•	•	•
F-150 (SA Key)			1	1	1	1				•	•	•	•	•	•	•	•	•	•	•	•	•	•	•	•	•	•	•	•
F-150 (SA Key)						1				•	•	•	•	•	•	•	•	•	•	•	•	•	•	•	•	•	•	•	•
F-250	1									•	•	•	•	•	•	•	•	•	•	•	•	•	•	•	•	•	•	•	•
F-250 (SA Key)		1	1	1	1	1				•	•	•	•	•	•	•	•	•	•	•	•	•	•	•	•	•	•	•	•
F-350	1									•	•	•	•	•	•	•	•	•	•	•	•	•	•	•	•	•	•	•	•
F-350 (SA Key)		1	1	1	1	1				•	•	•	•	•	•	•	•	•	•	•	•	•	•	•	•	•	•	•	•
F-450	1									•	•	•	•	•	•	•	•	•	•	•	•	•	•	•	•	•	•	•	•
F-450 (SA Key)		1	1	1	1	1				•	•	•	•	•	•	•	•	•	•	•	•	•	•	•	•	•	•	•	•
Flex	1	1								•	•	•	•	•	•	•	•	•	•	•	•	•	•	•	•	•	•	•	•
Flex					1	1	1			•	•	•	•	•	•	•	•	•	•	•	•	•	•	•	•	•	•	•	•
Flex (SA Key)			1	1	1	1				•	•	•	•	•	•	•	•	•	•	•	•	•	•	•	•	•	•	•	•
Fusion (SA Key)					1	1				•	•	•	•	•	•	•	•	•	•	•	•	•	•	•	•	•	•	•	•
Mustang (SA Key)			1	1						•	•	•	•	•	•	•	•	•	•	•	•	•	•	•	•	•	•	•	•
Taurus (SA Key)			1	1						•	•	•	•	•	•	•	•	•	•	•	•	•	•	•	•	•	•	•	•
Lincoln																													
Navigator 4			1	1	1	1				•	•	•	•	•	•	•	•	•	•	•	•	•	•	•	•	•	•	•	•

Legend:

- DL: OE Door Lock & Alarm Controls
- FOB: Sync CAN Interface w/ FOB Remote
- PK: Transponder & Immobilizer Override
- RS: Remote Start & Engine Controls
- SS: Integrated Security & Monitoring
- ST: Function/Feature Status

Wiring connections

The wiring connections listed below are specific to this firmware.

Main harness (H1), 12-pin black connector

Conn./Pin	Color	Description
H1/1	Blue/White	Relay 1 N.C. – No Connection ¹
H1/2	Blue/Red	Relay 1 N.O. – (+) 12V Input ¹
H1/3	Blue	Relay 1 COM – (+) Ignition Output ¹
H1/4	White/Brown	Relay 3 N.C. – No Connection ¹
H1/5	White	Relay 3 COM – (+) Parking Light Output ¹
H1/6	Red	(+) 12 Volt (Battery)
H1/7	Lt. Green/Red	Relay 2 N.O. – No Connection ¹
H1/8	Lt. Green	Relay 2 COM – RAP Off Interrupt ¹
H1/9	Lt. Green/White	Relay 2 N.C. – RAP Off Interrupt ¹
H1/10	Black	(-) Ground
H1/11	White	Relay 3 COM – Parking Light Output ¹
H1/12	Red	(+) 12 Volt (Battery)

Relay harness (H2), 10-pin white connector

Conn./Pin	Color	Description
H2/1	N/A	No Connection
H2/2	Red/Black	No Connection
H2/3	Pink/Black	No Connection ¹
H2/4	Pink/White	No Connection ¹
H2/5	Red	No Connection
H2/6	Green	No Connection ¹
H2/7	Violet	No Connection ¹
H2/8	Orange	No Connection ¹
H2/9	Red/White	No Connection
H2/10	Pink	No Connection

Data harness (H3), 8-pin white connector

Conn./Pin	Color	Description
H3/1	Tan	MS CAN Low
H3/2	Tan/Black	MS CAN High
H3/3	Orange/Brown	HS CAN High
H3/4	Orange/Green	HS CAN Low
H3/5	Lt. Green	No Connection
H3/6	Violet/Brown	No Connection
H3/7	Orange/Black	Data RX
H3/8	Yellow/Black	Data TX

1. If these outputs are not used by the firmware, they can be configured by the installer when the module is flashed.

Analog input/output harness (H4), 22-pin white connector

Conn./Pin	Color	Description
H4/1	Lt. Green/Black	No Connection ¹
H4/2	Blue/White	(-) Ground When Running (Status) Output ¹
H4/3	Dk. Green/Black	(-) Lock Output ¹
H4/4	Red/White	(-) Trunk Release Output ¹
H4/5	Brown/Black	(-) Horn ¹
H4/6	Brown/White	N/A
H4/7	White	(+) Accessory/Keysense Output ¹
H4/8	Violet/Black	(+) Starter Output ¹
H4/9	Dk. Blue/Black	(-) Unlock Output ¹
H4/10	Lt. Blue/Black	(-) Factory Alarm Disarm ¹
H4/11	Brown/Red	(+) Siren Output ¹
H4/12	Pink	(+) Ignition Sense Input
H4/13	Violet	(+) Door Input ²
H4/14	Brown	(+) Brake Input ²
H4/15	White/Blue	(-) Activation (Start Trigger) Input ²
H4/16	Red/Blue	No Connection ²
H4/17	Black/White	(-) Parking Brake Input (Manual Transmission) ²
H4/18	Orange/Black	(-) Instant Alarm Trigger Input ²
H4/19	Blue	(-) Trunk Trigger Input ²
H4/20	Green	(-) Door Input ²
H4/21	Gray	(-) Hood Pin Input ²
H4/22	Violet/White	(AC) Tach Input

RF Port harness (H5), 2-pin white connector

Conn./Pin	Color	Description
H5/1	N/A	RF Loop
H5/2	N/A	RF Loop

D2D harness (H6), 4-pin white (1) and black (2) connectors

Conn./Pin	Color	Description
H6/1	Blue	(Data) TX
H6/2	Black	(-) Ground
H6/3	Green	(Data) RX
H6/4	Red	(+) 12 Volt

Temperature sensor harness (H7), 2-pin black connector

Conn./Pin	Color	Description
H7/1	Black	Temperature Sensor
H7/2	Black	Temperature Sensor

1. If these outputs are not used by the firmware, they can be configured by the installer when the module is flashed. Note that they are low current and a relay may be necessary.
2. These connections are only required if the corresponding statuses are not supported by the firmware. See "Vehicle application guide" on page 5 for a list of compatible features. If these outputs are not used by the firmware, they can be configured by the installer when the module is flashed. Note that they are low current and a relay may be necessary.

Installation (wiring diagrams, fuse selection & vehicle wiring reference charts)

Type 1 - with T-Harness (THFON1)

⚠ Refer to "Pre-installation and application warnings" on page 4 and "Vehicle wiring reference chart" on page 10 for important information on this installation.

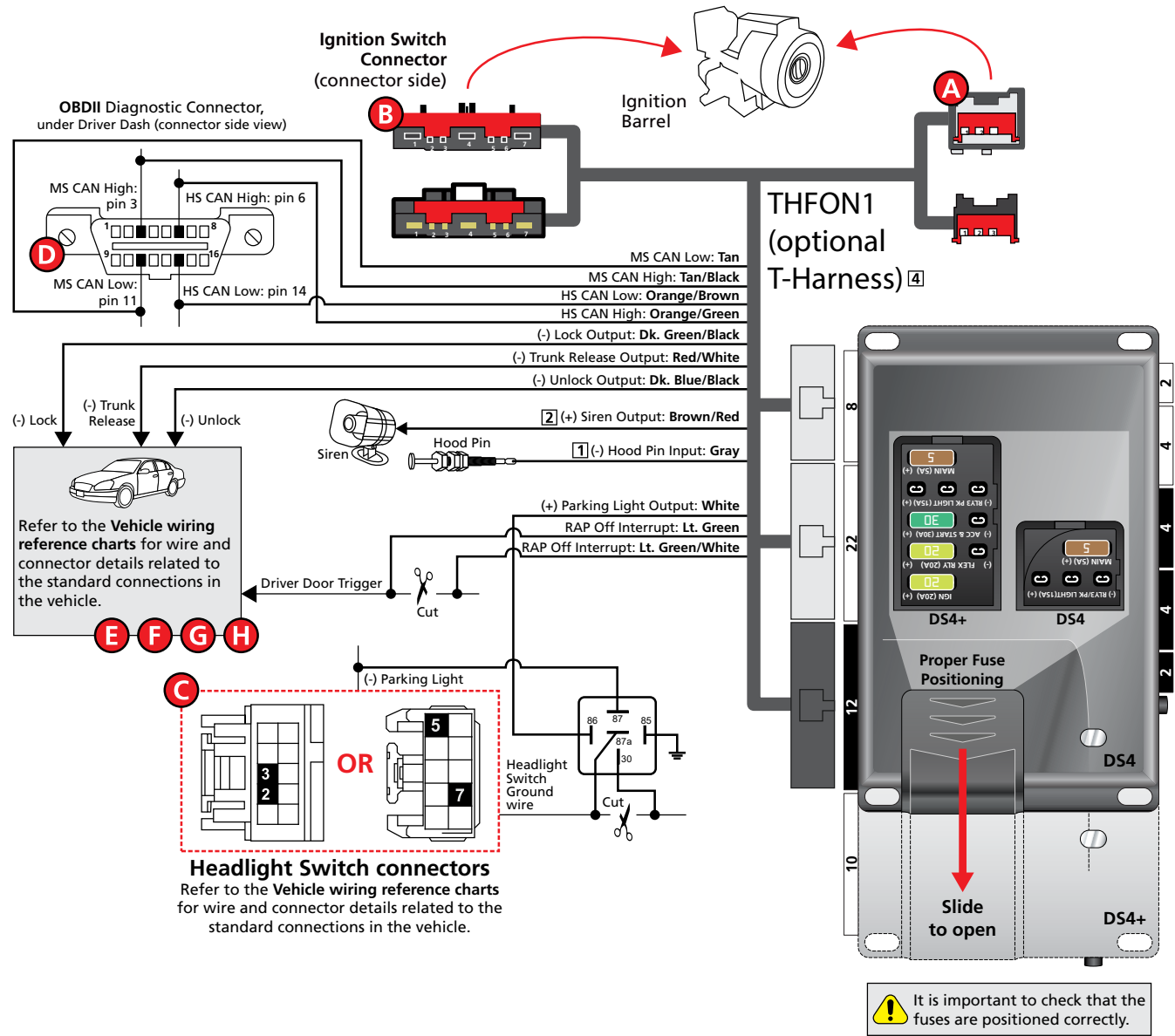

Type 1

Refer to "Pre-installation and application warnings" on page 4 and "Vehicle wiring reference chart" on page 10 for important information on this installation.

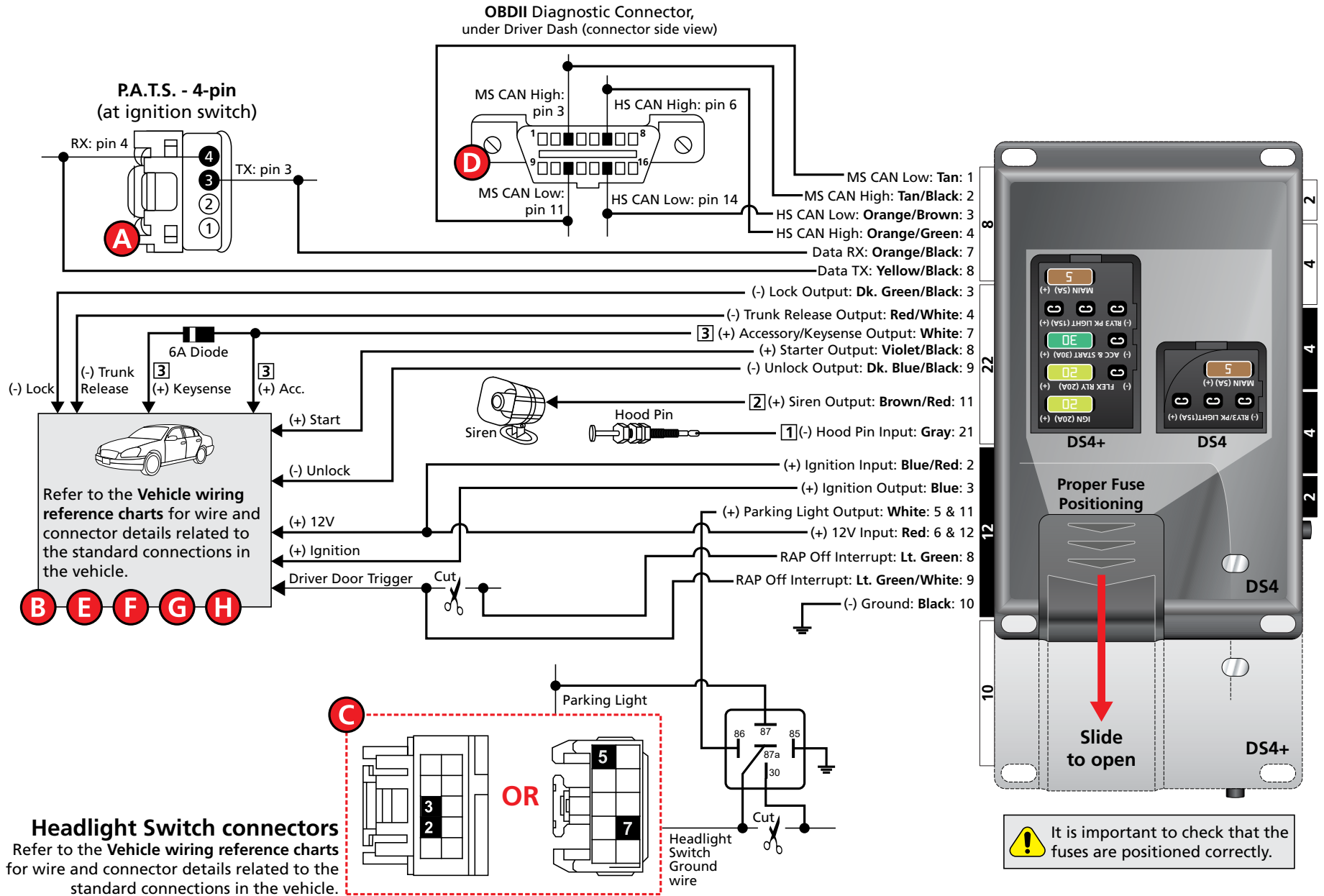

Vehicle wiring reference chart

This section provides vehicle wiring information to guide you through the various stages of your installation. Refer to www.directechs.com for additional information.

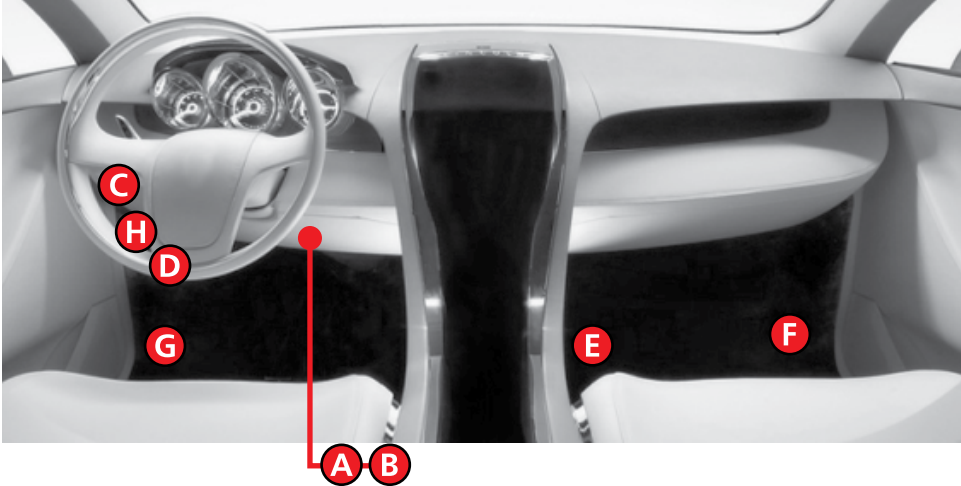

Wire Information				Connector Information			
Function	Color	Pin	Polarity	Location	Color	Pins	Ref.
Ford E-Series (SA Key) 2014							
RX	Violet/Gray	4	Data	PATS connector at ignition switch	Black	4	A
TX	Yellow/Orange	3	Data	PATS connector at ignition switch	Black	4	A
Headlight Switch Ground	Black/Blue	3	(-)	Headlight Switch	Gray	10	C
Parking Lights	Gray	2	(-)	Headlight Switch	Gray	10	C
12V	Blue/Red	2	(+)	Ignition Switch	Gray	13	B
Accessory	Brown/Yellow	8	(+)	Ignition Switch	Gray	13	B
Ignition	White/Orange	1	(+)	Ignition Switch	Gray	13	B
Keysense	Blue/Gray	10	(+)	Ignition Switch	Gray	13	B
Start	Blue/White	5	(+)	Ignition Switch	Gray	13	B
MS CAN High	Gray/Orange	3	Data	OBDII Diagnostic Connector	Black	16	D
MS CAN Low	Violet/Orange	11	Data	OBDII Diagnostic Connector	Black	16	D
HS CAN High	White/Blue	6	Data	OBDII Diagnostic Connector	Black	16	D
HS CAN Low	White	14	Data	OBDII Diagnostic Connector	Black	16	D
Driver Door Trigger	Green/Violet	14	Cut	BCM/SJB in driver side dash	Gray	26	H
Lock	Gray/Yellow	17	(-)	SJB in driver side dash	Gray	26	H
Unlock	Violet/Gray	4	(-)	SJB in driver side dash	Gray	26	H

Wire Information				Connector Information			
Function	Color	Pin	Polarity	Location	Color	Pins	Ref.
Ford Escape 2008-2012							
RX	Violet/Gray	4	Data	PATS connector at ignition switch	Black	4	A
TX	Yellow/Orange	3	Data	PATS connector at ignition switch	Black	4	A
Headlight Switch Ground	Black/Blue	7	(-)	Headlight Switch	Gray	10	C
Parking Lights	Blue/Gray	5	(-)	Headlight Switch	Gray	10	C
12V	Blue/Red	4	(+)	Ignition Switch	Gray	7	B
Accessory	Violet/Green	6	(+)	Ignition Switch	Gray	7	B
Ignition	White/Orange	1	(+)	Ignition Switch	Gray	7	B
Keysense	Blue/Gray	5	(+)	Ignition Switch	Gray	7	B
Start	Blue/White	7	(+)	Ignition Switch	Gray	7	B
MS CAN High	Gray/Orange	3	Data	OBDII Diagnostic Connector	Black	16	D
MS CAN Low	Violet/Orange	11	Data	OBDII Diagnostic Connector	Black	16	D
HS CAN High	White/Blue	6	Data	OBDII Diagnostic Connector	Black	16	D
HS CAN Low	White	14	Data	OBDII Diagnostic Connector	Black	16	D
Driver Door Trigger	Green/Violet	14	Cut	BCM/SJB in passenger side center console	Gray	26	E
Trunk/Hatch Release	Brown	7	(-)	BCM/SJB in passenger side center console	Gray	26	E
Lock	Blue/Green	17	(-)	SJB in passenger side center console	Gray	26	E
Unlock	Yellow/Violet	4	(-)	SJB in passenger side center console	Gray	26	E
Ford Escape Hybrid 2008-2012							
RX	Violet/Gray	4	Data	PATS connector at ignition switch	Black	4	A
TX	Yellow/Orange	3	Data	PATS connector at ignition switch	Black	4	A
Headlight Switch Ground	Black/Blue	7	(-)	Headlight Switch	Gray	10	C
Parking Lights	Blue/Gray	5	(-)	Headlight Switch	Gray	10	C
12V	Blue/Red	4	(+)	Ignition Switch	Gray	7	B
Accessory	Violet/Green	6	(+)	Ignition Switch	Gray	7	B
Ignition	White/Orange	1	(+)	Ignition Switch	Gray	7	B
Keysense	Blue/Gray	5	(+)	Ignition Switch	Gray	7	B
Start	Blue/White	7	(+)	Ignition Switch	Gray	7	B
MS CAN High	Gray/Orange	3	Data	OBDII Diagnostic Connector	Black	16	D
MS CAN Low	Violet/Orange	11	Data	OBDII Diagnostic Connector	Black	16	D
HS CAN High	White/Blue	6	Data	OBDII Diagnostic Connector	Black	16	D
HS CAN Low	White	14	Data	OBDII Diagnostic Connector	Black	16	D
Driver Door Trigger	Green/Violet	14	Cut	BCM/SJB in passenger side center console	Gray	26	E
Trunk/Hatch Release	Brown	7	(-)	BCM/SJB in passenger side center console	Gray	26	E
Lock	Blue/Green	17	(-)	SJB in passenger side center console	Gray	26	E
Unlock	Yellow/Violet	4	(-)	SJB in passenger side center console	Gray	26	E

Wire Information				Connector Information			
Function	Color	Pin	Polarity	Location	Color	Pins	Ref.
Ford Expedition 2015-2016							
RX	Blue/Gray	4	Data	P.A.T.S. connector at ignition switch.	Black	4	A
TX	Violet/Brown	3	Data	P.A.T.S. connector at ignition switch.	Black	4	A
Power Liftgate	Gray/Yellow	7	(-)	Power liftgate switch.	Black	8	H
Headlight Switch Ground	Black/White	7	(-)	Headlight switch	Gray	10	C
Parking Light	Gray	2	(-)	Headlight switch	Gray	10	C
12V	Green/Red	4	(+)	Ignition switch	Gray	7	B
Accessory	Violet/Green	7	(+)	Ignition switch	Gray	7	B
Ignition	White/Orange	1	(+)	Ignition switch	Gray	7	B
Keysense	Blue/Gray	5	(+)	Ignition switch	Gray	7	B
Start	Blue/White	7	(+)	Ignition switch	Gray	7	B
MS CAN High	Gray/Orange	3	Data	OBDII diagnostic connector.	Black	16	D
MS CAN Low	Violet/Orange	11	Data	OBDII diagnostic connector.	Black	16	D
HS CAN High	White/Blue	6	Data	OBDII diagnostic connector.	Black	16	D
HS CAN Low	White	14	Data	OBDII diagnostic connector.	Black	16	D
Driver Door Trigger	Green/Violet	9	Cut	BCM/SJB in passenger kick panel.	Gray	26	F
Lock	White/Brown	6	(-)	BCM/SJB in passenger kick panel.	Gray	26	F
Unlock	Blue/Brown	8	(-)	BCM/SJB in passenger kick panel.	Gray	26	F
Trunk/Hatch Release	Brown	23	(-)	BCM/SJB in passenger kick panel.	Gray	26	F
Ford Expedition (SA Key) 2011-2014							
RX	Blue/Gray	4	Data	P.A.T.S. connector at ignition switch.	Black	4	A
TX	Violet/Brown	3	Data	P.A.T.S. connector at ignition switch.	Black	4	A
Power Liftgate	Gray/Yellow	7	(-)	Power liftgate switch.	Black	8	H
Headlight Switch Ground	Black/White	7	(-)	Headlight switch	Gray	10	C
Parking Light	Blue/Gray	5	(-)	Headlight switch	Gray	10	C
12V	Blue/Red	8	(+)	Ignition switch	Gray	10	B
Accessory	Brown/Yellow	7	(+)	Ignition switch	Gray	10	B
Ignition	White/Orange	1	(+)	Ignition switch	Gray	10	B
Keysense	Blue/Gray	3	(+)	Ignition switch	Gray	10	B
Start	Blue/White	10	(+)	Ignition switch	Gray	10	B
MS CAN High	Gray/Orange	3	Data	OBDII diagnostic connector.	Black	16	D
MS CAN Low	Violet/Orange	11	Data	OBDII diagnostic connector.	Black	16	D
HS CAN High	White/Blue	6	Data	OBDII diagnostic connector.	Black	16	D
HS CAN Low	White	14	Data	OBDII diagnostic connector.	Black	16	D
Driver Door Trigger	Green/Violet	14	Cut	BCM/SJB in passenger kick panel.	Gray	26	F
Lock	White/Brown	17	(-)	BCM/SJB in passenger kick panel.	Gray	26	F
Unlock	Blue/Brown	4	(-)	BCM/SJB in passenger kick panel.	Gray	26	F
Trunk/Hatch Release	Brown	20	(-)	BCM/SJB in passenger kick panel.	Gray	26	F

Wire Information				Connector Information			
Function	Color	Pin	Polarity	Location	Color	Pins	Ref.
Ford F150 (SA Key) 2011-2014							
RX	Violet/Gray	4	Data	P.A.T.S. connector at ignition switch.	Black	4	A
TX	Yellow/Orange	3	Data	P.A.T.S. connector at ignition switch.	Black	4	A
12V	Green/Red	4	(+)	Ignition switch	Black	7	B
Accessory	Violet/Green	6	(+)	Ignition switch	Black	7	B
Ignition	White/Orange	1	(+)	Ignition switch	Black	7	B
Keysense	Blue/Gray	5	(+)	Ignition switch	Black	7	B
Start	Blue/White	7	(+)	Ignition switch	Black	7	B
Headlight Switch Ground	Black	3	(-)	Headlight switch	Gray	10	C
Parking Light	Gray	2	(-)	Headlight switch	Gray	10	C
MS CAN High	Gray/Orange	3	Data	OBDII diagnostic connector.	Black	16	D
MS CAN Low	Violet/Orange	11	Data	OBDII diagnostic connector.	Black	16	D
HS CAN High	White/Blue	6	Data	OBDII diagnostic connector.	Black	16	D
HS CAN Low	White	14	Data	OBDII diagnostic connector.	Black	16	D
Driver Door Trigger	Green/Violet	9	Cut	BCM/SJB in passenger kick panel or at driver kick panel harness.	Black	26	F or G
Lock	Blue/Green	6	(-)	BCM/SJB in passenger kick panel or at driver kick panel harness.	Black	26	F or G
Unlock	Yellow/Violet	8	(-)	BCM/SJB in passenger kick panel or at driver kick panel harness.	Black	26	F or G
Ford F250 2016							
RX	Yellow/Orange	4	Data	P.A.T.S. connector at ignition switch.	Black	4	A
TX	Violet/Gray	3	Data	P.A.T.S. connector at ignition switch.	Black	4	A
12V	Green/Red	4	(+)	Ignition switch	Black	7	B
Accessory	Violet/Green	6	(+)	Ignition switch	Black	7	B
Ignition	White/Orange	1	(+)	Ignition switch	Black	7	B
Keysense	Blue/Gray	5	(+)	Ignition switch	Black	7	B
Start	Blue/White	7	(+)	Ignition switch	Black	7	B
Headlight Switch Ground	Black/Gray	3	(-)	Headlight switch	Gray	10	C
Parking Light	Yellow/Orange	2	(-)	Headlight switch	Gray	10	C
MS CAN High	Gray/Orange	3	Data	OBDII diagnostic connector.	Black	16	D
MS CAN Low	Violet/Orange	11	Data	OBDII diagnostic connector.	Black	16	D
HS CAN High	White/Blue	6	Data	OBDII diagnostic connector.	Black	16	D
HS CAN Low	White	14	Data	OBDII diagnostic connector.	Black	16	D
Driver Door Trigger	Green/Violet	9	Cut	BCM/SJB in passenger kick panel or at driver kick panel harness.	Black	26	F or G
Lock	Blue/Green	6	(-)	BCM/SJB in passenger kick panel or at driver kick panel harness.	Black	26	F or G
Unlock	Yellow/Violet	8	(-)	BCM/SJB in passenger kick panel or at driver kick panel harness.	Black	26	F or G

Wire Information				Connector Information			
Function	Color	Pin	Polarity	Location	Color	Pins	Ref.
Ford F250 (SA Key) 2011-2015							
RX	Yellow/Orange	4	Data	P.A.T.S. connector at ignition switch.	Black	4	A
TX	Violet/Gray	3	Data	P.A.T.S. connector at ignition switch.	Black	4	A
12V	Green/Red or Blue/Red	4	(+)	Ignition switch	Black	7	B
Accessory	Violet/Green	6	(+)	Ignition switch	Black	7	B
Ignition	White/Orange	1	(+)	Ignition switch	Black	7	B
Keysense	Blue/Gray	5	(+)	Ignition switch	Black	7	B
Start	Blue/White	7	(+)	Ignition switch	Black	7	B
Headlight Switch Ground	Black/Gray	3	(-)	Headlight switch	Gray	10	C
Parking Light	Yellow/Orange	2	(-)	Headlight switch	Gray	10	C
MS CAN High	Gray/Orange	3	Data	OBDII diagnostic connector.	Black	16	D
MS CAN Low	Violet/Orange	11	Data	OBDII diagnostic connector.	Black	16	D
HS CAN High	White/Blue	6	Data	OBDII diagnostic connector.	Black	16	D
HS CAN Low	White	14	Data	OBDII diagnostic connector.	Black	16	D
Driver Door Trigger	Green/Violet	9	Cut	BCM/SJB in passenger kick panel or at driver kick panel harness.	Black	26	F or G
Lock	Blue/Green	6	(-)	BCM/SJB in passenger kick panel or at driver kick panel harness.	Black	26	F or G
Unlock	Yellow/Violet	8	(-)	BCM/SJB in passenger kick panel or at driver kick panel harness.	Black	26	F or G
Ford F350 2016							
RX	Yellow/Orange	4	Data	P.A.T.S. connector at ignition switch.	Black	4	A
TX	Violet/Gray	3	Data	P.A.T.S. connector at ignition switch.	Black	4	A
12V	Green/Red	4	(+)	Ignition switch	Black	7	B
Accessory	Violet/Green	6	(+)	Ignition switch	Black	7	B
Ignition	White/Orange	1	(+)	Ignition switch	Black	7	B
Keysense	Blue/Gray	5	(+)	Ignition switch	Black	7	B
Start	Blue/White	7	(+)	Ignition switch	Black	7	B
Headlight Switch Ground	Black/Gray	3	(-)	Headlight switch	Gray	10	C
Parking Light	Yellow/Orange	2	(-)	Headlight switch	Gray	10	C
MS CAN High	Gray/Orange	3	Data	OBDII diagnostic connector.	Black	16	D
MS CAN Low	Violet/Orange	11	Data	OBDII diagnostic connector.	Black	16	D
HS CAN High	White/Blue	6	Data	OBDII diagnostic connector.	Black	16	D
HS CAN Low	White	14	Data	OBDII diagnostic connector.	Black	16	D
Driver Door Trigger	Green/Violet	9	Cut	BCM/SJB in passenger kick panel or at driver kick panel harness.	Black	26	F or G
Lock	Blue/Green	6	(-)	BCM/SJB in passenger kick panel or at driver kick panel harness.	Black	26	F or G
Unlock	Yellow/Violet	8	(-)	BCM/SJB in passenger kick panel or at driver kick panel harness.	Black	26	F or G

Wire Information				Connector Information			
Function	Color	Pin	Polarity	Location	Color	Pins	Ref.
Ford F350 (SA Key) 2011-2015							
RX	Yellow/Orange	4	Data	P.A.T.S. connector at ignition switch.	Black	4	A
TX	Violet/Gray	3	Data	P.A.T.S. connector at ignition switch.	Black	4	A
12V	Green/Red or Blue/Red	4	(+)	Ignition switch	Black	7	B
Accessory	Violet/Green	6	(+)	Ignition switch	Black	7	B
Ignition	White/Orange	1	(+)	Ignition switch	Black	7	B
Keysense	Blue/Gray	5	(+)	Ignition switch	Black	7	B
Start	Blue/White	7	(+)	Ignition switch	Black	7	B
Headlight Switch Ground	Black/Gray	3	(-)	Headlight switch	Gray	10	C
Parking Light	Yellow/Orange	2	(-)	Headlight switch	Gray	10	C
MS CAN High	Gray/Orange	3	Data	OBDII diagnostic connector.	Black	16	D
MS CAN Low	Violet/Orange	11	Data	OBDII diagnostic connector.	Black	16	D
HS CAN High	White/Blue	6	Data	OBDII diagnostic connector.	Black	16	D
HS CAN Low	White	14	Data	OBDII diagnostic connector.	Black	16	D
Driver Door Trigger	Green/Violet	9	Cut	BCM/SJB in passenger kick panel or at driver kick panel harness.	Black	26	F or G
Lock	Blue/Green	6	(-)	BCM/SJB in passenger kick panel or at driver kick panel harness.	Black	26	F or G
Unlock	Yellow/Violet	8	(-)	BCM/SJB in passenger kick panel or at driver kick panel harness.	Black	26	F or G
Ford F450 2016							
RX	Yellow/Orange	4	Data	P.A.T.S. connector at ignition switch.	Black	4	A
TX	Violet/Gray	3	Data	P.A.T.S. connector at ignition switch.	Black	4	A
12V	Green/Red	4	(+)	Ignition switch	Black	7	B
Accessory	Violet/Green	6	(+)	Ignition switch	Black	7	B
Ignition	White/Orange	1	(+)	Ignition switch	Black	7	B
Keysense	Blue/Gray	5	(+)	Ignition switch	Black	7	B
Start	Blue/White	7	(+)	Ignition switch	Black	7	B
Headlight Switch Ground	Black/Gray	3	(-)	Headlight switch	Gray	10	C
Parking Light	Yellow/Orange	2	(-)	Headlight switch	Gray	10	C
MS CAN High	Gray/Orange	3	Data	OBDII diagnostic connector.	Black	16	D
MS CAN Low	Violet/Orange	11	Data	OBDII diagnostic connector.	Black	16	D
HS CAN High	White/Blue	6	Data	OBDII diagnostic connector.	Black	16	D
HS CAN Low	White	14	Data	OBDII diagnostic connector.	Black	16	D
Driver Door Trigger	Green/Violet	9	Cut	BCM/SJB in passenger kick panel or at driver kick panel harness.	Black	26	F or G
Lock	Blue/Green	6	(-)	BCM/SJB in passenger kick panel or at driver kick panel harness.	Black	26	F or G
Unlock	Yellow/Violet	8	(-)	BCM/SJB in passenger kick panel or at driver kick panel harness.	Black	26	F or G

Wire Information				Connector Information			
Function	Color	Pin	Polarity	Location	Color	Pins	Ref.
Ford F450 (SA Key) 2011-2015							
RX	Yellow/Orange	4	Data	P.A.T.S. connector at ignition switch.	Black	4	A
TX	Violet/Gray	3	Data	P.A.T.S. connector at ignition switch.	Black	4	A
12V	Green/Red	4	(+)	Ignition switch	Black	7	B
Accessory	Violet/Green	6	(+)	Ignition switch	Black	7	B
Ignition	White/Orange	1	(+)	Ignition switch	Black	7	B
Keysense	Blue/Gray	5	(+)	Ignition switch	Black	7	B
Start	Blue/White	7	(+)	Ignition switch	Black	7	B
Headlight Switch Ground	Black/Gray	3	(-)	Headlight switch	Gray	10	C
Parking Light	Yellow/Orange	2	(-)	Headlight switch	Gray	10	C
MS CAN High	Gray/Orange	3	Data	OBDII diagnostic connector.	Black	16	D
MS CAN Low	Violet/Orange	11	Data	OBDII diagnostic connector.	Black	16	D
HS CAN High	White/Blue	6	Data	OBDII diagnostic connector.	Black	16	D
HS CAN Low	White	14	Data	OBDII diagnostic connector.	Black	16	D
Driver Door Trigger	Green/Violet	9	Cut	BCM/SJB in passenger kick panel or at driver kick panel harness.	Black	26	F or G
Lock	Blue/Green	6	(-)	BCM/SJB in passenger kick panel or at driver kick panel harness.	Black	26	F or G
Unlock	Yellow/Violet	8	(-)	BCM/SJB in passenger kick panel or at driver kick panel harness.	Black	26	F or G
Ford Flex 2015-2016							
RX	Violet	4	Data	P.A.T.S. connector at ignition switch.	Black	4	A
TX	Yellow	3	Data	P.A.T.S. connector at ignition switch.	Black	4	A
Power Liftgate	Gray	6	(-)	Power liftgate switch.	Black	6	H
Accessory	Violet	6	(+)	Ignition switch	Black	7	B
Ignition	White/Orange	1	(+)	Ignition switch	Black	7	B
Keysense	Blue	5	(+)	Ignition switch	Black	7	B
Start	Blue/White	7	(+)	Ignition switch	Black	7	B
Headlight Switch Ground	Black/Blue	3	(-)	Headlight switch	Gray	10	C
Parking Light	Gray	2	(-)	Headlight switch	Gray	10	C
MS CAN High	Gray/Orange	3	Data	OBDII diagnostic connector.	Black	16	D
MS CAN Low	Violet/Orange	11	Data	OBDII diagnostic connector.	Black	16	D
HS CAN High	White/Blue	6	Data	OBDII diagnostic connector.	Black	16	D
HS CAN Low	White	14	Data	OBDII diagnostic connector.	Black	16	D
Driver Door Trigger	Violet	9	Cut	BCM/SJB under driver dash.	Gray	26	H
Lock	Blue	6	(-)	BCM/SJB under driver dash.	Gray	26	H
Unlock	Yellow	8	(-)	BCM/SJB under driver dash.	Gray	26	H
12V	Red	6	(+)	BCM/SJB under driver dash.	White	32	H
Trunk/Hatch Release	Brown	23	(-)	BCM/SJB under driver dash.	Black	26	H

Wire Information				Connector Information			
Function	Color	Pin	Polarity	Location	Color	Pins	Ref.
Ford Flex 2009-2011							
RX	Violet/Gray	4	Data	P.A.T.S. connector at ignition switch.	Black	4	A
TX	Yellow/Orange	3	Data	P.A.T.S. connector at ignition switch.	Black	4	A
Power Liftgate	Gray/Yellow	6	(-)	Power liftgate switch.	Black	6	H
12V	Blue/Red	4	(+)	Ignition switch	Black	7	B
Accessory	Violet/Green	6	(+)	Ignition switch	Black	7	B
Ignition	White/Orange	1	(+)	Ignition switch	Black	7	B
Keysense	Blue/Gray	5	(+)	Ignition switch	Black	7	B
Start	Blue/White	7	(+)	Ignition switch	Black	7	B
Headlight Switch Ground	Black/Blue	3	(-)	Headlight switch	Gray	10	C
Parking Light	Gray	2	(-)	Headlight switch	Gray	10	C
MS CAN High	Gray/Orange	3	Data	OBDII diagnostic connector.	Black	16	D
MS CAN Low	Violet/Orange	11	Data	OBDII diagnostic connector.	Black	16	D
HS CAN High	White/Blue	6	Data	OBDII diagnostic connector.	Black	16	D
HS CAN Low	White	14	Data	OBDII diagnostic connector.	Black	16	D
Driver Door Trigger	Green/Violet	14	Cut	BCM/SJB under driver dash.	Gray	26	H
Lock	Blue/Green	17	(-)	BCM/SJB under driver dash.	Gray	26	H
Trunk/Hatch Release	Brown	7	(-)	BCM/SJB under driver dash.	Gray	26	H
Unlock	Yellow/Violet	4	(-)	BCM/SJB under driver dash.	Gray	26	H
Ford Flex (SA Key) 2011-2012							
RX	Violet/Gray	4	Data	P.A.T.S. connector at ignition switch.	Black	4	A
TX	Yellow/Orange	3	Data	P.A.T.S. connector at ignition switch.	Black	4	A
Power Liftgate	Gray/Yellow	6	(-)	Power liftgate switch.	Black	6	H
12V	Blue/Red	4	(+)	Ignition switch	Black	7	B
Accessory	Violet/Green	6	(+)	Ignition switch	Black	7	B
Ignition	White/Orange	1	(+)	Ignition switch	Black	7	B
Keysense	Blue/Gray	5	(+)	Ignition switch	Black	7	B
Start	Blue/White	7	(+)	Ignition switch	Black	7	B
Headlight Switch Ground	Black/Blue	3	(-)	Headlight switch	Gray	10	C
Parking Light	Gray	2	(-)	Headlight switch	Gray	10	C
MS CAN High	Gray/Orange	3	Data	OBDII diagnostic connector.	Black	16	D
MS CAN Low	Violet/Orange	11	Data	OBDII diagnostic connector.	Black	16	D
HS CAN High	White/Blue	6	Data	OBDII diagnostic connector.	Black	16	D
HS CAN Low	White	14	Data	OBDII diagnostic connector.	Black	16	D
Driver Door Trigger	Green/Violet	14	Cut	BCM/SJB under driver dash.	Gray	26	H
Lock	Blue/Green	17	(-)	BCM/SJB under driver dash.	Gray	26	H
Trunk/Hatch Release	Brown	7	(-)	BCM/SJB under driver dash.	Gray	26	H
Unlock	Yellow/Violet	4	(-)	BCM/SJB under driver dash.	Gray	26	H

Wire Information				Connector Information			
Function	Color	Pin	Polarity	Location	Color	Pins	Ref.
Ford Flex (SA Key) 2013-2014							
RX	Violet	4	Data	P.A.T.S. connector at ignition switch.	Black	4	A
TX	Yellow	3	Data	P.A.T.S. connector at ignition switch.	Black	4	A
Power Liftgate	Gray	6	(-)	Power liftgate switch.	Black	6	H
Accessory	Violet	6	(+)	Ignition switch	Black	7	B
Ignition	White/Orange	1	(+)	Ignition switch	Black	7	B
Keysense	Blue	5	(+)	Ignition switch	Black	7	B
Start	Blue/White	7	(+)	Ignition switch	Black	7	B
Headlight Switch Ground	Black/Blue	3	(-)	Headlight switch	Gray	10	C
Parking Light	Gray	2	(-)	Headlight switch	Gray	10	C
MS CAN High	Gray/Orange	3	Data	OBDII diagnostic connector.	Black	16	D
MS CAN Low	Violet/Orange	11	Data	OBDII diagnostic connector.	Black	16	D
HS CAN High	White/Blue	6	Data	OBDII diagnostic connector.	Black	16	D
HS CAN Low	White	14	Data	OBDII diagnostic connector.	Black	16	D
Driver Door Trigger	Green/Violet	9	Cut	BCM/SJB under driver dash.	Gray	26	H
Lock	Blue	6	(-)	BCM/SJB under driver dash.	Gray	26	H
Trunk/Hatch Release	Brown	23	(-)	BCM/SJB under driver dash.	Gray	26	H
12V	Red	6	(+)	BCM/SJB under driver dash.	White	32	H
Ford Fusion (SA Key) 2011-2012							
RX	Yellow/Orange	4	Data	P.A.T.S. connector at ignition switch.	Black	4	A
TX	Violet/Gray	3	Data	P.A.T.S. connector at ignition switch.	Black	4	A
12V	Blue/Red	4	(+)	Ignition switch	Black	7	B
Accessory	Violet/Green	6	(+)	Ignition switch	Black	7	B
Ignition	White/Orange	1	(+)	Ignition switch	Black	7	B
Keysense	Blue/Gray	5	(+)	Ignition switch	Black	7	B
Start	Blue/White	7	(+)	Ignition switch	Black	7	B
Headlight Switch Ground	Black/Violet	3	(-)	Headlight switch	Gray	10	C
Parking Light	Gray	2	(-)	Headlight switch	Gray	10	C
MS CAN High	Gray/Orange	3	Data	OBDII diagnostic connector.	Black	16	D
MS CAN Low	Violet/Orange	11	Data	OBDII diagnostic connector.	Black	16	D
HS CAN High	White/Blue	6	Data	OBDII diagnostic connector.	Black	16	D
HS CAN Low	White	14	Data	OBDII diagnostic connector.	Black	16	D
Driver Door Trigger	Green/Violet	14	Cut	BCM/SJB under driver dash.	Gray	26	H
Lock	Blue/Green	17	(-)	BCM/SJB under driver dash.	Gray	26	H
Trunk/Hatch Release	Brown/Yellow	20	(-)	BCM/SJB under driver dash.	Gray	26	H
Unlock	Yellow/Violet	4	(-)	BCM/SJB under driver dash.	Gray	26	H

Wire Information				Connector Information			
Function	Color	Pin	Polarity	Location	Color	Pins	Ref.
Ford Mustang (SA Key) 2013-2014							
RX	Yellow/Orange	4	Data	P.A.T.S. connector at ignition switch.	Black	4	A
TX	Violet/Gray	3	Data	P.A.T.S. connector at ignition switch.	Black	4	A
12V	Blue/Red	4	(+)	Ignition switch	Black	7	B
Accessory	Violet/Green	6	(+)	Ignition switch	Black	7	B
Ignition	Gray/Violet	1	(+)	Ignition switch	Black	7	B
Keysense	Blue/Gray	5	(+)	Ignition switch	Black	7	B
Start	Blue/White	7	(+)	Ignition switch	Black	7	B
Headlight Switch Ground	Black/Violet	3	(-)	Headlight switch	Gray	10	C
Parking Light	Gray	2	(-)	Headlight switch	Gray	10	C
MS CAN High	Gray/Orange	3	Data	OBDII diagnostic connector.	Black	16	D
MS CAN Low	Violet/Orange	11	Data	OBDII diagnostic connector.	Black	16	D
HS CAN High	White/Blue	6	Data	OBDII diagnostic connector.	Black	16	D
HS CAN Low	White	14	Data	OBDII diagnostic connector.	Black	16	D
Driver Door Trigger	Green/Violet	14	Cut	BCM/SJB in passenger kick panel or at driver kick panel harness.	Gray	26	F or G
Lock	Blue/Green	17	(-)	BCM/SJB in passenger kick panel or at driver kick panel harness.	Gray	26	F or G
Trunk/Hatch Release	"Brown/Yellow or Brown/Violet"	20	(-)	BCM/SJB in passenger kick panel or at driver kick panel harness.	Gray	26	F or G
Unlock	Yellow/Violet	4	(-)	BCM/SJB in passenger kick panel or at driver kick panel harness.	Gray	26	F or G
Ford Taurus (SA Key) 2013-2014							
RX	Violet/Gray	4	Data	P.A.T.S. connector at ignition switch.	Black	4	A
TX	Yellow/Orange	3	Data	P.A.T.S. connector at ignition switch.	Black	4	A
Accessory	Violet/Green	6	(+)	Ignition switch	Black	7	B
Ignition	White/Orange	1	(+)	Ignition switch	Black	7	B
Keysense	Blue/Gray	5	(+)	Ignition switch	Black	7	B
Start	Blue/White	7	(+)	Ignition switch	Black	7	B
Headlight Switch Ground	Black/White	3	(-)	Headlight switch	Gray	10	C
Parking Light	Gray	2	(-)	Headlight switch	Gray	10	C
MS CAN High	Gray/Orange	3	Data	OBDII diagnostic connector.	Black	16	D
MS CAN Low	Violet/Orange	11	Data	OBDII diagnostic connector.	Black	16	D
HS CAN High	Blue/White	6	Data	OBDII diagnostic connector.	Black	16	D
HS CAN Low	White	14	Data	OBDII diagnostic connector.	Black	16	D
Driver Door Trigger	Green/Violet	9	Open	BCM/SJB under driver dash.	Black	26	G
Lock	Blue/Green	6	(-)	BCM/SJB under driver dash.	Black	26	G
Trunk/Hatch Release	Brown/Yellow	23 or 4	(-)	BCM/SJB under driver dash.	Black	26	G
Unlock	Yellow/Violet	8	(-)	BCM/SJB under driver dash.	Black	26	G
12V	Red	6	(+)	BCM/SJB under driver dash.	White	32	G

Wire Information				Connector Information			
Function	Color	Pin	Polarity	Location	Color	Pins	Ref.
Lincoln Navigator 2011-2014							
RX	Blue/Gray	4	Data	PATS connector at ignition switch	Black	4	A
TX	Violet/Brown	3	Data	PATS connector at ignition switch	Black	4	A
Power Liftgate	Gray/Yellow	7	(-)	Power liftgate switch	Black	8	H
Headlight Switch Ground	Black/White	7	(-)	Headlight Switch	Gray	10	C
Parking Lights	Blue/Gray	5	(-)	Headlight Switch	Gray	10	C
12V	Blue/Red	9	(+)	Ignition Switch	Gray	10	B
Accessory	Brown/Yellow	7	(+)	Ignition Switch	Gray	10	B
Accessory 2	Violet/Green	5	(+)	Ignition Switch	Gray	10	B
Ignition	White/Orange	1	(+)	Ignition Switch	Gray	10	B
Keysense	Blue/Gray	3	(+)	Ignition Switch	Gray	10	B
Start	Blue/White	10	(+)	Ignition Switch	Gray	10	B
MS CAN High	Gray/Orange	3	Data	OBDII Diagnostic Connector	Black	16	D
MS CAN Low	Violet/Orange	11	Data	OBDII Diagnostic Connector	Black	16	D
HS CAN high	White/Blue	6	Data	OBDII diagnostic connector.	Black	16	D
HS CAN Low	White	14	Data	OBDII diagnostic connector.	Black	16	D
Driver Door Trigger	Green/Violet	14	N.C.	BCM/SJB in passenger kick	Gray	26	F
Trunk/Hatch Release	Brown	7	(-)	BCM/SJB in passenger kick	Gray	26	F
Lock	White/Brown	17	(-)	SJB in passenger kick	Gray	26	F
Unlock	Blue/Brown	4	(-)	SJB in passenger kick	Gray	26	F

Type 2 - with T-Harness (THFON1)

⚠️ Refer to "Pre-installation and application warnings" on page 4 and "Vehicle wiring reference chart" on page 23 for important information on this installation.

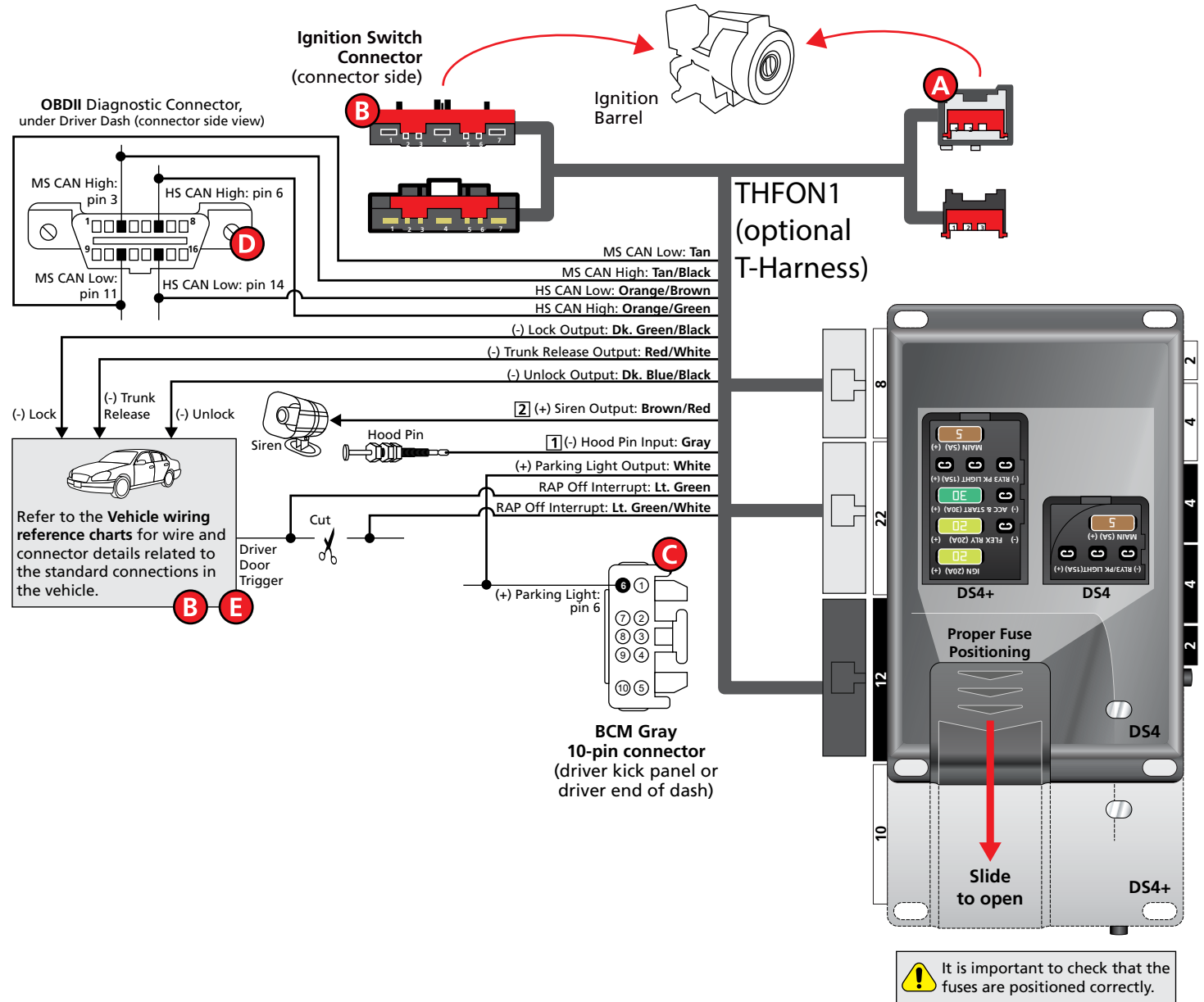

Type 2

 Refer to "Pre-installation and application warnings" on page 4 and "Vehicle wiring reference chart" on page 23 for important information on this installation.

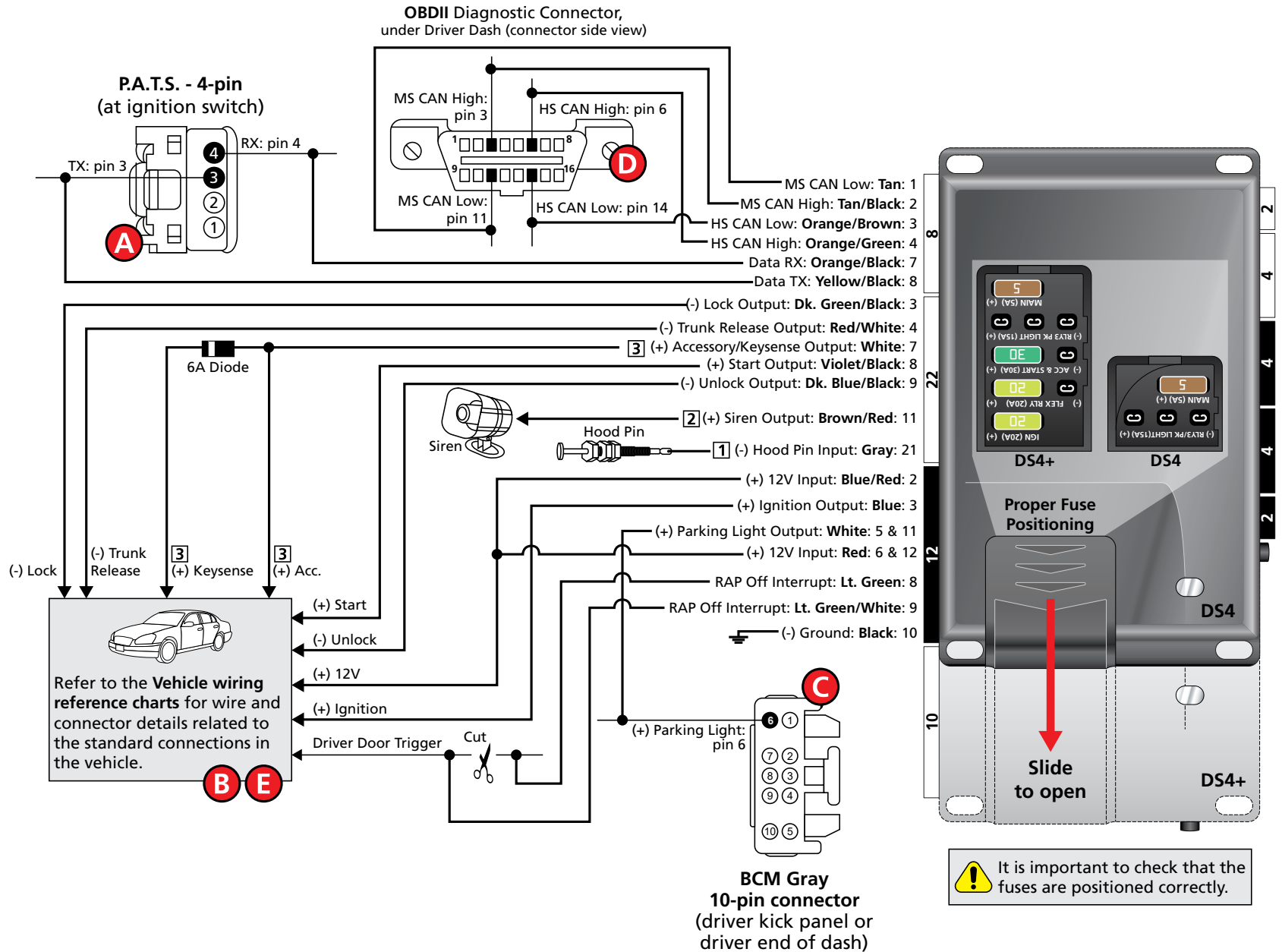

Vehicle wiring reference chart

This section provides vehicle wiring information to guide you through the various stages of your installation. Refer to www.directechs.com for additional information.

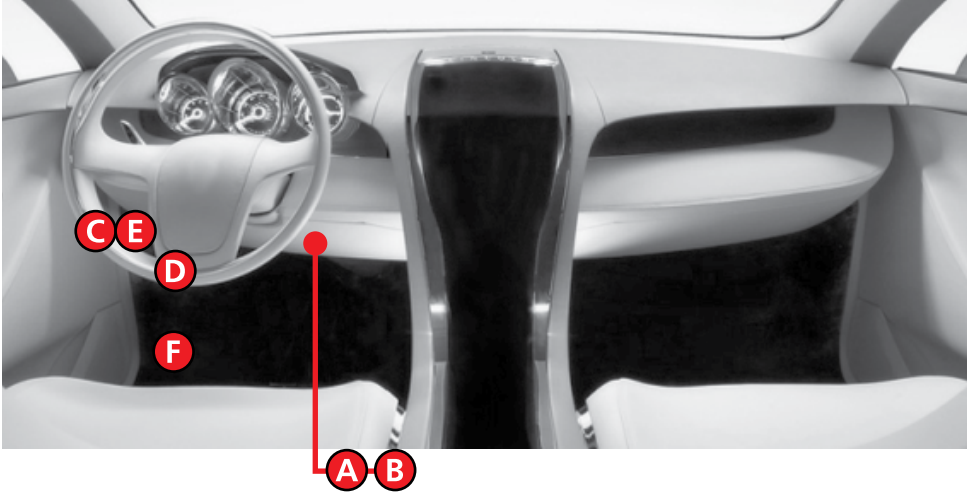

Wire Information				Connector Information			
Function	Color	Pin	Polarity	Location	Color	Pins	Ref.
Ford Explorer (SA Key) 2011-2015							
RX	Violet/Red or Violet	4	Data	P.A.T.S. connector at ignition switch.	Black	4	A
TX	Yellow/Orange or Yellow	3	Data	P.A.T.S. connector at ignition switch.	Black	4	A
Power Liftgate	Gray/Yellow	7	(-)	Power liftgate switch.	Black	8	E
12V	Green/Red	4	(+)	Ignition switch	Black	7	B
Accessory	Violet/Green	6	(+)	Ignition switch	Black	7	B
Ignition	White/Orange	1	(+)	Ignition switch	Black	7	B
Keysense	Blue/Gray	5	(+)	Ignition switch	Black	7	B
Start	Blue/White	7	(+)	Ignition switch	Black	7	B
Parking Light	Yellow/Blue	6	(+)	BCM/SJB under driver dash.	Gray	10	C
MS CAN High	Gray/Orange	3	Data	OBDII diagnostic connector.	Black	16	D
MS CAN Low	Violet/Orange	11	Data	OBDII diagnostic connector.	Black	16	D
HS CAN High	White/Blue	6	Data	OBDII diagnostic connector.	Black	16	D
HS CAN Low	White	14	Data	OBDII diagnostic connector.	Black	16	D
Driver Door Trigger	Green/Violet	9	Cut	BCM/SJB in driver kick panel.	Black	26	F
Lock	Blue/Green	6	(-)	BCM/SJB in driver kick panel.	Black	26	F
Trunk/Hatch Release	Brown	23	(-)	BCM/SJB in driver kick panel.	Black	26	F
Unlock	Yellow/Violet	8	(-)	BCM/SJB in driver kick panel.	Black	26	F

Wire Information				Connector Information			
Function	Color	Pin	Polarity	Location	Color	Pins	Ref.
Ford Edge (SA Key) 2011-2014							
RX	Violet/Gray	4	Data	P.A.T.S. connector at ignition switch.	Black	4	A
TX	Yellow/Orange	3	Data	P.A.T.S. connector at ignition switch.	Black	4	A
12V	Green/Red	4	(+)	Ignition switch	Black	7	B
Accessory	Violet/Green	6	(+)	Ignition switch	Black	7	B
Ignition	White/Orange	1	(+)	Ignition switch	Black	7	B
Keysense	Blue/Gray	5	(+)	Ignition switch	Black	7	B
Start	Blue/White	7	(+)	Ignition switch	Black	7	B
Power Liftgate	Gray/Yellow	6	(-)	Power liftgate switch.	Black	6	E
Parking Light	Yellow/Blue	6	(+)	BCM/SJB under driver dash.	Gray	10	C
Driver Door Trigger	Green/Violet	9	Cut	BCM/SJB under driver dash.	Black	26	C
Trunk/Hatch Release	Brown	23	(-)	BCM/SJB under driver dash.	Black	26	C
MS CAN High	Gray/Orange	3	Data	OBDII diagnostic connector.	Black	16	D
MS CAN Low	Violet/Orange	11	Data	OBDII diagnostic connector.	Black	16	D
HS CAN High	White/Blue	6	Data	OBDII diagnostic connector.	Black	16	D
HS CAN Low	White	14	Data	OBDII diagnostic connector.	Black	16	D
Lock	Blue/Green	6	(-)	BCM/SJB under driver dash.	Black	26	C
Unlock	Yellow/Violet	8	(-)	BCM/SJB under driver dash.	Black	26	C

Key2GO

 This feature is required if only one key is available. You can program the interface without the need for Key2GO if two keys are present.

Key2GO has been designed and developed to bypass the advanced encryption layers found in modern vehicles. It uses an array of servers to generate a duplicate of the original key, allowing the installation of a remote starter without having to give up a key.

The advantage is that this feature allows you to use one original key and the server to configure the bypass in the vehicle.

All Key2GO-compatible firmware are clearly indicated in the function list of each vehicle search result page and will also appear on the flash page. Any first-time user must re-register to gain access to Key2GO, and some additional information will be required to complete the registration process, such as your Directed account number and store name.

Key2GO is compatible with XKLoader2 and the online web tool, as well as XKLoader3 and the Directechs Mobile application.

Refer to "Module programming - 1-Key programming using Key2GO" on page 29 of this guide for instructions on how to program features using Key2GO.

Understanding the difference between a Ford 80 & 40 bit

Ford introduced an 80-bit encryption in late 2009 and this caused a lot of confusion as to which models it was available on. The main question is which models use the 80 and which use the old 40 bit?

Contrary to popular belief, the SA marking on the key does NOT indicate a vehicle uses 80-bit encryption. In reality, the SA marking indicates that the key is 80-bit compatible, but the vehicle itself could still be using 40-bit encryption.

What does it mean?

It means that Ford did in fact release SA keys equipped with an 80-bit transponder, but the reality is that the same transponder can also be used in 40-bit vehicle, making it backward compatible with older vehicles. Consequently, if you see an SA key it is important that you do not automatically assume it is an 80-bit type. It all depends on the vehicle, not the key.

How do I differentiate between the 40 & 80 bit?

To determine which encryption type you are dealing with, you must test pin 1 at the 4-pin IMMO connector on the key barrel for the following conditions to determine if it is 40 or 80-bit type.

An **80**-bit vehicle should provide the following values:

- NO key in barrel: 0V
- Key in barrel with IGN OFF: (+) 12V
- Key in barrel with IGN ON: (+) 12V

A **40**-bit vehicle should provide the following values:

- NO key in barrel: 0V
- Key in barrel with IGN OFF: 0V
- Key in barrel with IGN ON: (+) 12V

Configuring the system

Important!

Once the DS4+ module is installed in the vehicle following the instructions in "Installation (wiring diagrams, fuse selection & vehicle wiring reference charts)" on page 8, **launch** the DirectLink application on your mobile device, and **select** Configure DS4+/DS4+. **Follow** the on-screen instructions to configure the system.

Note: Your system can also be configured using XKLoader2 on www.directechs.com.

Vehicles equipped with a manual transmission

Additional connections may be required if these functions are not supported by the firmware.

Connection	Description
(-) E-Brake Status Input (Black/White, pin 17)	Must be connected to a working emergency brake in the vehicle. Although most vehicles have simple (-) trigger emergency brake circuits note some vehicles do not and may require unique integration methodologies.
(-) Door Trigger Input (Green, pin 20) OR (+) Door Input (Violet, pin 13)	Must be connected to a working door trigger in the vehicle, which monitors all doors. The unit must monitor the door pins to allow the Ready Mode process to be enabled. Note: Some vehicles may require unique integration methodologies for this circuit. For more information, refer to www.directechs.com .
(AC) Tachometer Input (Violet/White, pin 22)	Must be connected to a working tachometer signal in the vehicle (fuel injector, ignition coil, true tach, etc.) and learned successfully to the DS4+.

RF Systems

An RF System consists of one or multiple remotes, a Control Center (antenna), and an antenna cable – various combinations exist. An RF System allows the vehicle owner to control the system with enhanced range. Two-way models are available. Please follow the instructions included with the kit for appropriate installation and programming information.

8504D Combo Sensor

The 8504D Combo Sensor must be paired to the device before it can be used. To enter pairing, **turn** the vehicle ignition to the ON position, then **press** and **hold** the programming button on the Control Center (antenna) until the LED starts flashing. Once pairing mode has been entered, your Combo Sensor is ready to use.

Your Combo Sensor is preset for the majority of applications, however it can be adjusted using the DirectLink application, as well as a compatible LED or LCD remote. Please refer to the instructions included with your sensor for more information on how to make adjustments.

When used in conjunction with SmartStart

To enable D2D communication between the DS4+ and the SmartStart one of the following actions must be executed:

- SmartStart with **Loops** – The brown loop must be cut.
- SmartStart with **Pigtails** – The gray wire must be connected to a ground source.

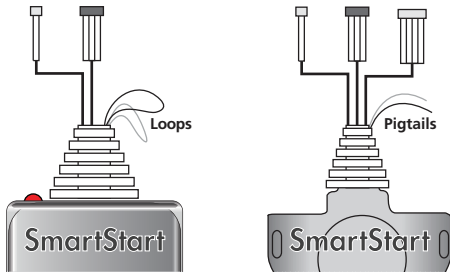

! **DO NOT** connect the SmartStart 2-pin power harness when using the DS4+. Power and ground will be provided by the D2D connector on main module. Refer to the SmartStart documentation for further details.

D2D port configuration

The system will automatically configure the D2D ports based on your selections in the module programming. The white D2D port is reserved for SmartStart. To ensure proper functionality with SmartStart, it is important that it is selected in the system programming of the DirectLink application or via the online web tool.

Note: Both black D2D ports are reserved for the Control Center (antenna) and 8504D Combo Sensor.

Module programming - Using 2 Keys

 Refer to "LED diagnostics and troubleshooting" on page 30 for more information and for troubleshooting purposes.



To connect the module:

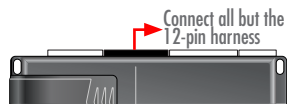

- 1** Please **ensure** that the vehicle is in a safe location and cannot move forward during programming. For vehicles equipped with a manual transmission, make sure the gearshift lever is in the neutral position.

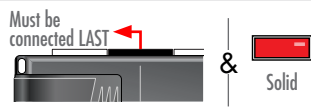

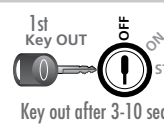

- 2** **Connect** all the harnesses to the DS4+, **EXCEPT** the 12-pin main power harness.

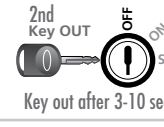
- 3** **Connect** the 12-pin main power harness, and wait until the LED turns ON solid red.



- 4** **Insert** the first key and **turn** it to the ON position, **wait** at least 3 seconds but no more than 10 seconds then **remove** it. The LED flashes green.





- 5** Within 5 seconds, **insert** the second key and **turn** it to the ON position, **wait** at least 3 seconds but no more than 10 seconds then **remove** it. The LED now flashes orange, otherwise repeat steps 4 and 5.



- 6** **Wait** for at least 3 seconds, but no more than 10 seconds, and **press** and **hold** the programming button. The vehicle ignition turns ON. The LED turns ON solid green for 3 seconds, then turns OFF.

Note: Release the Program button as soon as the orange LED goes out. If you wait too long to release the programming button, you will have to start the programming over.
- 7** **Pair** remotes (if applicable). For information on how to pair a specific remote, please refer to its corresponding owner documentation, which can be found inside the product packaging of the complete system or on www.directechs.com. *

- 8** By default, the tachometer is preprogrammed for the vehicle. For instructions on how to program tach, see page 33.



* Your aftermarket remote may differ from the model shown in the illustrations.

You have successfully completed the module programming sequence.

Module programming - 1-Key programming using Key2GO

 Refer to "LED diagnostics and troubleshooting" on page 30 for more information and for troubleshooting purposes.

To connect the module:

- 1** Please **ensure** that the vehicle is in a safe location and cannot move forward during programming. For vehicles equipped with a manual transmission, make sure the gearshift lever is in the neutral position.

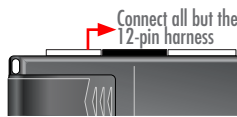

- 2** **Connect** all the harnesses to the DS4+, **EXCEPT** the 12-pin main power harness.



Connect all but the 12-pin harness
- 3** **Connect** the 12-pin main power harness, and wait until the LED turns ON solid red.

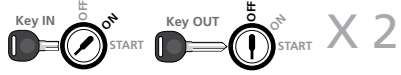

Must be connected LAST & Solid
- 4** **Insert** the key and **turn** ignition ON and OFF twice. The LED now flashes orange.



& Flashes Orange
- 5** **Remove** the module from the vehicle and **reconnect** it to your computer. The Directechs web site will automatically recognize that you are moving on to the second phase of the programming sequence.
- 6** **Select** the methos and click on [Submit Key2GO Request](#).
- 7** Once the configuration is completed, **reconnect** the unit to the vehicle. The LED then turns ON solid green for 3 seconds once the module is successfully programmed.



Solid x 3 secs
- 8** **Pair** remotes (if applicable). For information on how to pair a specific remote, please refer to its corresponding owner documentation, which can be found inside the product packaging of the complete system or on www.directechs.com.*



Pair remotes*
- 9** By default, the tachometer is preprogrammed for the vehicle. For instructions on how to program tach, see page 65.



Initialize tachometer









* Your aftermarket remote may differ from the model shown in the illustrations.

You have successfully completed the module programming sequence.









LED diagnostics and troubleshooting

This section provides LED diagnostics and troubleshooting information to guide you through the various stages of your installation.

Module programming

LED	Description	Troubleshooting
 Off	Module has no power.	Make sure the D2D harness is connected and that 12 Volt is present between the red and black wires. If 12 Volt is present, the module may be defective.
 Solid red	Waiting to begin the programming sequence.	Ensure the correct programming procedure is being followed.
 Flashes red & green	Initialization failed.	Reset the module and complete the programming again. If the issue persists, please contact Technical Support.
 Solid orange	Transponder functions were skipped.	(If compatible) when the RXT mode is not desired or convenience features are needed, please reset and reprogram the module.
 Flashes green	All required CAN networks has been detected.	Normal operation.
 Flashes orange	1 of 2 CAN networks has been detected.	Normal operation.
 Flashes orange slowly	Key2GO initiated.	Please follow the steps indicated in "Module programming - 1-Key programming using Key2GO" on page 29 to complete the Key2GO programming.
 Solid green x 3 secs	Module was successfully programmed with all functions.	Normal operation.
 Solid orange x 3 secs	Module was successfully programmed without transponder functions.	Normal operation.





Module programming – Error codes

LED	Description	Troubleshooting
 Flashes red x 1	CAN2 not detected.	Check the CAN2 Orange/Green and Orange/Brown wire connections. Wake up the data bus by turning the ignition on and try again. If your installation does not require this connection, skip this step by pressing the programming button 5 times.
 Flashes red x 1	J1850 not detected.	Check the J1850 wire connection. Wake up the data bus by turning the ignition on and try again.
 Flashes red x 2	CAN1 not detected.	Check the CAN1 Tan and Tan/Black wire connections. Wake up the data bus by turning the ignition on and try again. If your installation does not require this connection, skip this step by pressing the programming button 5 times.
 Flashes red x 3	Bypass data not detected.	Check the bypass line connection. If more than one wire is used, make sure they are not inverted. Ensure the vehicle still operates correctly using the factory key.
 Flashes red x 4	Bypass processing error.	The bypass calculation failed. Reset the module and try again. If the condition persists, please contact Technical Support.
 Flashes red x 5	ISO 1 not detected.	The Yellow/Black wire did not detect the expected signal. Refer to "Installation (wiring diagrams, fuse selection & vehicle wiring reference charts)" on page 8 to check the connections.
 Flashes red x 6	ISO 2 not detected.	The Orange/Black wire did not detect the expected signal. Refer to "Installation (wiring diagrams, fuse selection & vehicle wiring reference charts)" on page 8 to check the connections.
 Flashes red x 7	MUX not detected.	The Violet/Green or Violet/Brown wire did not detect the expected voltage value. Refer to "Installation (wiring diagrams, fuse selection & vehicle wiring reference charts)" on page 8 to check the connections.







External module synchronization

LED	Description	Troubleshooting
 (Flashes red, red, then orange) x 10	OBDII feature not supported.	The diagnostic data bus was not detected, therefore the SmartStart features will be limited.





Active Ground When Running (Status)

LED	Description	Troubleshooting
 Flashes green	Ground When Running (Status) command received.	The module has initialized the remote start sequence.
 Flashes red & orange	Ignition ON command received.	The module has received the Ignition ON command and is processing the remote start sequence.
 Flashes green quickly	Start ON command received.	The module has received the Start ON command and is processing the remote start sequence.
 Flashes red x 10	PTS shutdown error.	The PTS output from the module was not activated due to safety protection.
 Flashes red x 21	CAN bus incorrectly detected.	Verify the CAN1 and CAN2 connections. Refer to "Installation (wiring diagrams, fuse selection & vehicle wiring reference charts)" on page 8 to check the connections.

Commands

LED	Description	Troubleshooting
 Flashes orange x 1	LOCK command received.	If the bypass module fails to flash, it did not receive the signal. Commands can come from RF or D2D.
 Flashes orange x 2	UNLOCK command received.	
 Flashes orange x 3	TRUNK command received.	
 Flashes orange x 4	AUX1 command received.	
 Flashes orange x 5	AUX2 command received.	
 Flashes orange x 6	AUX3 command received.	

Shutdown codes

LED	Description	Troubleshooting
 Flashes green x 1	Takeover successful.	Normal operation.
 Flashes red x 1	Runsafe was not disabled.	No UNLOCK command was received prior to opening the door, or the 45 second timer expired in takeover mode.
 Flashes red x 2	Brake was not detected.	The brakes were not detected, which prevents the system from shutting down the vehicle.
 Flashes red x 3	Smart key was not detected.	The smart key was not detected, which prevents the system from shutting down the vehicle.
 Flashes red x 4	Speed was detected.	The vehicle was detected as moving, which prevents the system from shutting it down.

Analog error codes

LED	Description	Troubleshooting
 Flashes red, green & orange	DEI feature error.	A feature config file mismatch was detected. Please contact Technical Support.

Soft reset

A module reset will only erase the steps performed in "Module programming - Using 2 Keys" on page 28. The firmware and settings flashed to the module will not be affected.

- 1 If required for your installation, **connect** all the harnesses to the DS4+, **EXCEPT** the 12-pin main power harness. **Press** and **hold** the programming button, then **connect** the 12-pin harness to the module.

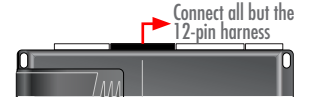

- 2 **Wait** 3 seconds until the LED turns ON solid orange then **release** the programming button. The LED turns ON solid red.



Hard reset

Warning Against Executing a Hard Reset!

A hard reset will revert the flashed firmware back to its default settings. Depending on the installation, some settings may need to be reconfigured. Connect your module to a computer and use the web configuration tool to edit its programmable features.

- 1 If required for your installation, **connect** all the harnesses to the DS4+, **EXCEPT** the 12-pin main power harness. **Press** and **hold** the programming button, then **connect** the 12-pin harness to the module.

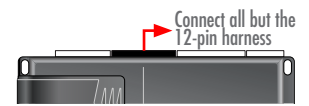

- 2 After 3 seconds the LED turns ON solid orange. **Keep holding** the programming button until the LED flashes red, then orange slowly.

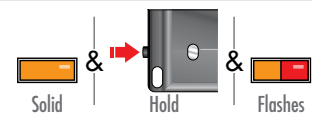

- 3 **Release** the programming button. The LED turns ON solid red.



Learning the Tach (not needed with Virtual Tach)

Tach comes preprogrammed, therefore learning is not required; however, it can be readjusted with the following operations:

1. Start the vehicle using the key.
2. Within 5 seconds, press and hold the Control Center* (antenna) or the main module programming button, until the LED on the Control Center (antenna) or the main module turns ON solid.
3. Release the button. Tachometer value is now stored in memory.

If the LED does not turn ON solid, find an alternate tach source.

* If the Control Center (antenna) was not included in your kit, the tach can be programmed using the programming button directly on the main module.

Note: When the tachometer is programmed, the main module automatically enters the Tachometer engine checking mode.

Initializing Virtual Tach (not needed with hardwired or data tach applications)

To program Virtual Tach:

1. After the install is complete, remote start the engine. The programming operation may require 3 cranks of the starter before the engine starts and runs. Do not turn off the remote start if this happens, it is a normal programming operation.
2. Once the engine begins running, let it run for at least 30 seconds.
3. Using the Remote, send the Remote start command to turn remote start off. Virtual Tach is programmed. To reset Virtual Tach, a module reset must be done.

Note: Virtual Tach cannot be used in Manual Transmission Mode. It is also not recommended for diesel trucks.

Virtual Tach handles disengaging the starter motor during remote starting – it does not address over-rev. If the customer wants to have the over-rev protection capability, the tach wire or data tach must be used.

Important! After successfully learning Virtual Tach, a small minority of vehicle starters may over crank or under crank during remote start. Use the VirtualTach Fine tune feature in the configuration wizard to adjust the starter output time in 50mS increments to compensate for such an occurrence.

Limited lifetime consumer warranty

Directed Electronics. ("Directed") promises to the original purchaser to repair or replace (at Directed's election) with a comparable reconditioned model any Directed unit (hereafter the "unit"), excluding without limitation the siren, the remote transmitters, the associated sensors and accessories, which proves to be defective in workmanship or material under reasonable use during the lifetime of the vehicle provided the following conditions are met: the unit was purchased from an authorized Directed dealer, the unit was professionally installed and serviced by an authorized Directed dealer; the unit will be professionally reinstalled in the vehicle in which it was originally installed by an authorized Directed dealer; and the unit is returned to Directed, shipping prepaid with a legible copy of the bill of sale or other dated proof of purchase bearing the following information: consumer's name, telephone number and address; the authorized dealers name, telephone number and address; complete product description, including accessories; the year, make and model of the vehicle; vehicle license number and vehicle identification number. All components other than the unit, including without limitation the siren, the remote transmitters and the associated sensors and accessories, carry a one-year warranty from the date of purchase of the same. ALL PRODUCTS RECEIVED BY DIRECTED FOR WARRANTY REPAIR WITHOUT PROOF OF PURCHASE FROM AN AUTHORIZED DEALER WILL BE DENIED. This warranty is non-transferable and is automatically void if: the unit's date code or serial number is defaced, missing or altered; the unit has been modified or used in a manner contrary to its intended purpose; the unit has been damaged by accident, unreasonable use, neglect, improper service, installation or other causes not arising out of defects in materials or construction. The warranty does not cover damage to the unit caused by installation or removal of the unit. Directed, in its sole discretion, will determine what constitutes excessive damage and may refuse the return of any unit with excessive damage.

TO THE MAXIMUM EXTENT ALLOWED BY LAW, ALL WARRANTIES, INCLUDING BUT NOT LIMITED TO EXPRESS WARRANTY, IMPLIED WARRANTY, WARRANTY OF MERCHANTABILITY, FITNESS FOR PARTICULAR PURPOSE AND WARRANTY OF NON-INFRINGEMENT OF INTELLECTUAL PROPERTY, ARE EXPRESSLY EXCLUDED; AND DIRECTED NEITHER ASSUMES NOR AUTHORIZES ANY PERSON OR ENTITY TO ASSUME FOR IT ANY DUTY, OBLIGATION OR LIABILITY IN CONNECTION WITH ITS PRODUCTS. DIRECTED DISCLAIMS AND HAS ABSOLUTELY NO LIABILITY FOR ANY AND ALL ACTS OF THIRD PARTIES INCLUDING ITS AUTHORIZED DEALERS OR INSTALLERS. DIRECTED SECURITY SYSTEMS, INCLUDING THIS UNIT, ARE DETERRENENTS AGAINST POSSIBLE THEFT. DIRECTED IS NOT OFFERING A GUARANTEE OR INSURANCE AGAINST VANDALISM, DAMAGE OR THEFT OF THE AUTOMOBILE, ITS PARTS OR CONTENTS; AND HEREBY EXPRESSLY DISCLAIMS ANY LIABILITY WHATSOEVER, INCLUDING WITHOUT LIMITATION, LIABILITY FOR THEFT, DAMAGE AND/OR VANDALISM. THIS WARRANTY DOES NOT COVER LABOR COSTS FOR MAINTENANCE, REMOVAL OR REINSTALLATION OF THE UNIT OR ANY CONSEQUENTIAL DAMAGES OF ANY KIND. IN THE EVENT OF A CLAIM OR A DISPUTE INVOLVING DIRECTED OR ITS SUBSIDIARY, THE VENUE SHALL BE SAN DIEGO COUNTY IN THE STATE OF CALIFORNIA. CALIFORNIA STATE LAWS AND APPLICABLE FEDERAL LAWS SHALL APPLY AND GOVERN THE DISPUTE. THE MAXIMUM RECOVERY UNDER ANY CLAIM AGAINST DIRECTED SHALL BE STRICTLY LIMITED TO THE AUTHORIZED DIRECTED DEALER'S PURCHASE PRICE OF THE UNIT. DIRECTED SHALL NOT BE RESPONSIBLE FOR ANY DAMAGES WHATSOEVER, INCLUDING BUT NOT LIMITED TO, ANY CONSEQUENTIAL DAMAGES, INCIDENTAL DAMAGES, DAMAGE TO VEHICLE, DAMAGES FOR THE LOSS OF TIME, LOSS OF EARNINGS, COMMERCIAL LOSS, LOSS OF ECONOMIC OPPORTUNITY AND THE LIKE. NOTWITHSTANDING THE ABOVE, THE MANUFACTURER DOES OFFER A LIMITED WARRANTY TO REPLACE OR REPAIR THE CONTROL MODULE SUBJECT TO THE CONDITIONS AS DESCRIBED HEREIN. THIS WARRANTY IS VOID IF THE UNIT HAS NOT BEEN PURCHASED FROM DIRECTED, OR AN AUTHORIZED DIRECTED DEALER, OR IF THE UNIT HAS BEEN DAMAGED BY ACCIDENT, UNREASONABLE USE, NEGLIGENCE, ACTS OF GOD, NEGLIGENCE, IMPROPER SERVICE, OR OTHER CAUSES NOT ARISING OUT OF DEFECT IN MATERIALS OR CONSTRUCTION.

Some states do not allow limitations on how long an implied warranty will last or the exclusion or limitation of incidental or consequential damages. This warranty gives you specific legal rights and you may also have other rights that vary from State to State.

This warranty is only valid for sale of product(s) within the United States of America and in Canada. Product(s) sold outside of the United States of America or Canada are sold "AS-IS" and shall have NO WARRANTY, express or implied.

For further details relating to warranty information of Directed products, please visit the support section of Directed's website at: www.directed.com.

This product may be covered by a Guaranteed Protection Plan ("GPP"). See your authorized Directed dealer for details of the plan or call Directed Customer Service at 1-800-876-0800.

(920-10011-01 2011-06)

Quick Reference Guide





Sending commands to your vehicle

Whether you want to remote start the engine, lock/unlock the doors or pop the trunk, there are 3 possible ways you can send commands to your vehicle, using the:

- Factory remote.
- Aftermarket remote.
- Directed SmartStart application via your smartphone.

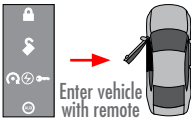

If applicable, you can also start the engine remotely by pressing the Lock button 3 times quickly on your factory remote.

Vehicle takeover with regular key

- 1 **Close** the vehicle doors, hood and trunk, then **send** the Remote Start command to start the vehicle.* 
- 2 **Send** the Unlock command on the factory or aftermarket remote.* 
- 3 **Enter** the vehicle, while making sure the factory remote is inside with you. 
- 4 **Insert** your key in the ignition barrel and **turn** it to the ON position. 
- 5 **Depress** the brake pedal, **put** the car in gear and **drive** off. 

* Icon and remote appearance may differ depending on the model purchased.



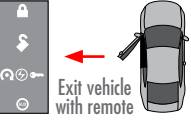

Pit stop/idle mode

- 1 **Stop** the vehicle in a safe parking spot and **put** the gear in Park (P). 
- 2 **Press** the Remote Start button on the transmitter.*  &  The parking lights will flash once to indicate the vehicle is now in Pit Stop Mode.
- 3 It is safe to **leave** the engine running and **exit** the vehicle with the factory remote in hand.  **Note:** We recommend that you always **lock** the doors of your vehicle when leaving it unattended.

* Icon and remote appearance may differ depending on the model purchased.

List of available commands

Note that the information below is for many Viper, Clifford, Python, Autostart and AstroStart models. Icons and commands may differ depending on the model and options purchased. Refer to your authorized installation center for more specific information.

Button(s)	Actions
	Press & hold for 1 second to lock.
	Press & hold for 1 second to unlock.
 *	Press & hold for 1 second to remote start.
 *	Press & hold for 5 seconds to activate the trunk release (optional).

* Icon and remote appearance may differ depending on the model purchased.

SmartStart compatible

This system is compatible with Directed SmartStart. For a complete list of supported features, please visit www.mysmartstart.com.

What is SmartStart?

Now you can remote start, lock and unlock your car just by pushing a button on your smartphone; using the SmartStart App from Directed, the leader in vehicle security and remote start. The simple graphical interface gives you control over the following features of your installed remote start or security with remote start system:

- Lock/Arm
- Unlock/Disarm
- Remote Car Starter
- Trunk Release
- Panic
- Aux Channels

You can also control multiple vehicles – great for families – and assign more than one user to control a vehicle. It's easy with SmartStart! But, this is only the beginning! SmartStart is loaded with additional features including GPS tracking, SmartSchedule, vehicle status, roadside assistance, parked car finder and more.

The application enables a “Cloud-Connected Car” like never before, providing 2-way interaction with your vehicle. Connectivity is managed through the Directed Cloud Services (DCS) network linking car, app, end user, and the Internet.

For more information, visit www.mysmartstart.com.

Notes
