

FORGING SOLUTIONS

Design Engineering Information From FIA

IMPRESSION DIE – CASE STUDIES

TABLE OF CONTENTS

Switch From Casting to Forging Increased Life of Large Connecting Rod

Forged Blocker Doors Used to Slow Planes on Landing Provided Cost Savings Compared to Fabricated Part Design

Precision Forging Provided Critical Properties and Cost Savings Over Machined Block

Forged Microalloyed Steel Delivered Right Combination of Strength and Toughness for Crankshafts

Forged Chain Stronger, Tougher and Outlasted Castings

Precision Forging Virtually Eliminates Machining, Cuts Cost of Large Structural Aircraft Part

Forged Adapter Cuts Cost by 50%, Resists 2000-psi Pressure Where Casting Could Not

Slack Adjuster Outperformed Casting, Cut Weight, Achieved Optimum ‘Value-Added’ Design on Trucks

Forged Microalloyed Steel Crankshaft Replaced ADI in High-Performance Engine

Ready-to-Assemble, Forged Steering Arm Replaced Weldment

Forged Tube Support Replaced Bar Stock, Eliminated All Machining and Cuts Cost by 85%

CVJ ‘tulip’ Finished As-forged, Cut Cost and Eliminated Expensive Machining Operations

Capability Analysis Brought Process into Control, Boosted Quality of Forged Automotive Parts

Co-Operative Redesign Delivered Forged Stop Nut, Eliminated Machining, and Consolidated Parts

Redesign Plus Teamwork Produced a Forged Part, Saving 80% in Material Cost Over Casting

Forged-microalloyed Yoke for Driveline Delivered Net Savings Plus Increased Performance

Forged Aluminum Ejector Cut Cost, Provided Critical Dimensions

Forging Techniques Made Steel Cam Cost-effective for High-volume Production

Forged Microalloyed Steel Engine Mount Cut Cost, Outperformed Alternatives

Forged Track Links Perform, Thanks to Harden-and-Temper + Induction

Forging Replaced Casting in Friction-welded Assembly, Cut Cost by Streamlining Manufacturing Operations

FORGING SOLUTIONS

Addressing these processes:

Impression Die ✓

Open Die

Rolled Ring

Cold

Design Engineering Information From FIA

CASE STUDY FROM THE FILES:

Switch from casting to forging increased life of large connecting rod

Field failures, an expensive proposition in terms of downtime and major pump damage, showed that cast connecting rods used to drive the pumps that keep coal slurry moving through pipelines were not strong enough.

The solution to the problem was found by redesigning the cast connecting rod as a forging. By refining grain flow in the closed-die hammer forging process, additional strength was distributed to the points of highest stress. Forging not only boosted the magnitude of the tensile strength over the cast version, but also significantly improved the strength of the connecting rods in the transverse direction. With the alternating stresses that the rod experiences while in service, longer life as a result of improved fatigue strength also became a reality.

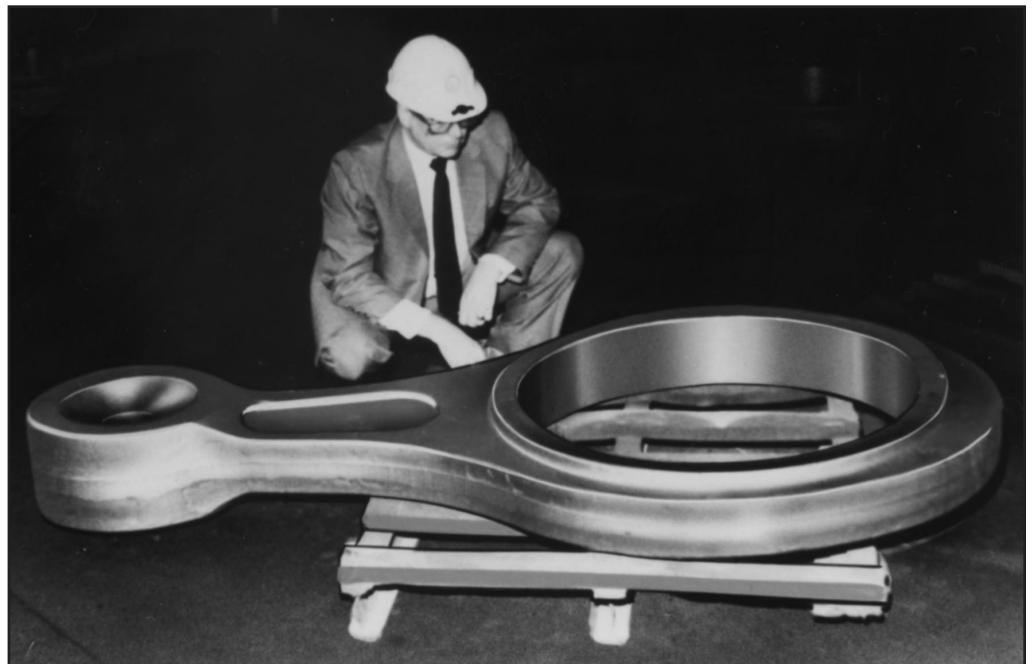

Refined grain flow in a 2450 lb. steel connecting rod delivers improved transverse strength, permitted a forging to succeed where a casting failed.

The forged 4140 steel connecting rod achieved critical straightness and thickness tolerances. See figure above. Tolerances are an important consideration, since as-forged surfaces must meet critical dimensional requirements to ensure a trouble-free installation. The tight tolerances permitted a large portion of the plan view area to be used as forged without subsequent finish machining.

As larger, more powerful pumps are designed and built to move greater volumes of slurry through larger pipelines over longer distances, the improved performance of forged connecting rods can increase the reliability of the pumps.

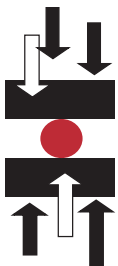

FORGING INDUSTRY ASSOCIATION

25 West Prospect Ave., Suite 300, Cleveland, OH 44115

Phone: 216-781-6260 Fax: 216-781-0102

E-mail: info@forging.org Website: www.forging.org

© Copyright 2007, Forging Industry Association

FORGING SOLUTIONS

Addressing these processes:

Impression Die ✓

Open Die

Rolled Ring

Cold

Design Engineering Information From FIA

CASE STUDY FROM THE FILES:

Forged blocker doors used to slow planes on landing provided cost savings compared to fabricated part design

Previously made as a complex fabricated build-up, precision forged aluminum blocker doors for jet engines delivered what is estimated as severalfold cost savings.

Actuated by the thrust reversers in a jet engine to reverse the jet stream and slow down a plane upon landing, the blocker doors were previously a built-up structure, consisting of aluminum sheet and honeycomb, which are both adhesively bonded and mechanically fastened.

As a one-piece forging, the re-designed blocker door incorporated integral stiffening ribs and a hinge attachment, both of which were formed to net shape. The only subsequent operation – a single symmetrical machining set-up – was performed on the conical-shaped back contour side. By establishing a single database to program tool paths for the EDM electrodes used to produce the forging dies, as well as for the machine/straightening fixture, the forger was able to achieve improved tolerances.

In addition to achieving savings in manufacturing and assembly, the forged doors were significantly more damage-tolerant than the sheet/honeycomb sandwich construction. As a result, longer service life provided further cost savings.

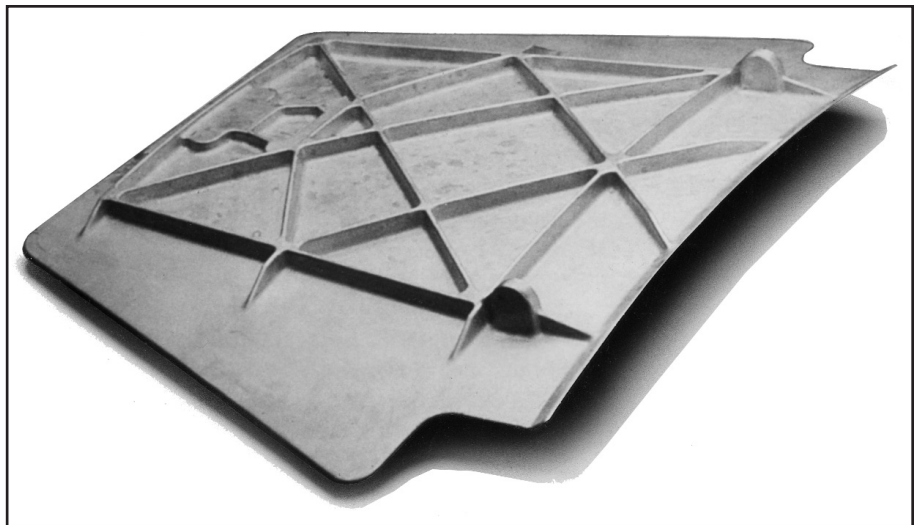

Precision forged of 2014-T6 aluminum to reduce cost, a blocker door for jet engines also outperformed its labor intensive fabricated predecessor. Shown are the detailed rib side and hinge attachment area, which was forged "net".

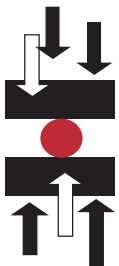

FORGING INDUSTRY ASSOCIATION

25 West Prospect Ave., Suite 300, Cleveland, OH 44115

Phone: 216-781-6260 Fax: 216-781-0102

E-mail: info@forging.org Website: www.forging.org

© Copyright 2007, Forging Industry Association

FORGING SOLUTIONS

Addressing these processes:

Impression Die ✓
Open Die
Rolled Ring
Cold

Design Engineering Information From FIA

CASE STUDY FROM THE FILES:

Precision forging provided critical properties and cost savings over machined block

A fracture-critical application, the flap track actuator bracket that supports the trailing-edge flap retraction mechanism on the A-320 Airbus was a “natural” for precision forged aluminum. The design not only demanded the safety and properties of forging, but also turned out to be extremely cost-effective, considering that alternatives would have required extensive, difficult machining to produce the complex shape. See figure on the right.

Performance requirements, including mechanical properties in thick sections, stress-corrosion resistance, and high fracture toughness, all ruled out castings. Additionally, the part was too big to be made by machining from plate. Consequently, the only other option was a “hogout” (extensive machining of a hand-forged block). This alternative was quickly dropped in favor of precision forging, since machining operations would not only have been very time-consuming and expensive, but also would have required cutting tools about the diameter of a pencil and 15 in. long to cut the sharp internal radii. Such tools would be prone to breakage, making machining an unreliable, tedious operation.

Because a failure of the part could have affected the proper raising or lowering of the flaps, 7050-T74 was chosen over more conventional aerospace aluminum alloys like 7075-T73, because of its good fracture toughness and its ability to maintain mechanical properties through sections up to 6 in. thick.

Ultimately, precision forging turned out to be more cost-effective than initially anticipated. The net-forged part, which required only minimal finish machining on some tight tolerance dimensions, cost the customer about 25% of what it would cost to machine a rectangular block.

Material savings was also a big contributor to cost savings. The hand-forged block weighed 175 lb.—more than 100 lb. greater than the 67 lb. starting material required for precision forging.



Made from a precision forged aluminum alloy, 7050-T74, the actuator brackets possessed high strength in thick sections. If the parts were machined from a rectangular block, the cost would have increased by four times as compared to the precision forging.

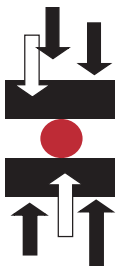

FORGING INDUSTRY ASSOCIATION

25 West Prospect Ave., Suite 300, Cleveland, OH 44115

Phone: 216-781-6260 Fax: 216-781-0102

E-mail: info@forging.org Website: www.forging.org

© Copyright 2007, Forging Industry Association

FORGING SOLUTIONS

Addressing these processes:

Impression Die ✓

Open Die

Rolled Ring

Cold

Design Engineering Information From FIA

CASE STUDY FROM THE FILES:

Forged microalloyed steel delivered right combination of strength and toughness for crankshafts

Crankshafts can be forged from vanadium microalloyed steel. The driving force, of course, is economics. 10% or more overall cost savings can be achieved by eliminating heat treatments that are standard procedure for quenched-and-tempered steels. See figure. Additional savings may also be realized from improved machinability.

Microalloyed steel is ideal for medium strength forging applications like crankshafts, which do not experience severe impact loads in service. Characterized as a low-carbon, higher-manganese version, the vanadium-modified microalloy comprises 0.3% C, 1.50% Mn, and 0.11% V. It possesses strength, hardness, and induction hardening

characteristics that are enhanced by the high Mn level and the microalloying element. The key to the crankshaft application is the development of a forging procedure that optimizes heating, hot working, and cooling of constant-volume, cylindrical steel billets. For example, lowering the forging temperature and increasing the forging reduction results in a finer austenite grain size, maximizing the ideal property combination.

Crankshafts forged from microalloyed steel can yield acceptable strength and toughness combinations for high-volume applications. Most important, both strength and hardness values are virtually identical from the surface to the center of the crankshaft. Ductility and toughness properties are slightly higher at the surface because of a finer grain size. Fatigue strength is estimated to be equivalent to that of a quenched-and-tempered plain carbon steel.

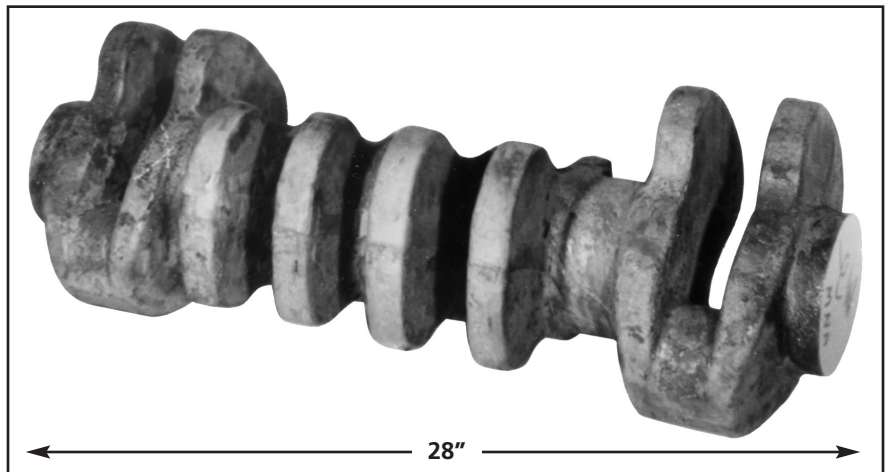

Starting with a 6 in. round cornered billets that were induction heated, the microalloyed steel crankshaft (5 in. main bearing diameter) was press forged, then fan cooled.

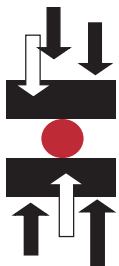

FORGING INDUSTRY ASSOCIATION

25 West Prospect Ave., Suite 300, Cleveland, OH 44115

Phone: 216-781-6260 Fax: 216-781-0102

E-mail: info@forging.org Website: www.forging.org

© Copyright 2007, Forging Industry Association

FORGING SOLUTIONS

Addressing these processes:

Impression Die ✓

Open Die

Rolled Ring

Cold

Design Engineering Information From FIA

CASE STUDY FROM THE FILES:

Forged chain stronger, tougher and outlasted castings

Used primarily in coal mining but also in other types of surface mining, giant dragline chains hoist buckets filled with coal, phosphate, or ore up from the mining site. As the old saying goes, "Any chain is only as strong as its weakest link."

One company found that cast dragline chains were not strong enough. The cast links were continually

failing. Engineers switched to forged chain links, significantly increasing service life over that of cast chains.

Forged chain links resulted in improved tensile strength, higher

toughness, and increased wear resistance, yielding a property profile unattainable by any other method of manufacture. See figure above. The alloy also had excellent weldability, ensuring the highest quality welds when chains are assembled.

Uniform chemical composition makes heat-treatment response more predictable, leading not only to more consistent properties from link to link, but also to better hardness control, which in turn boosts wear and abrasion resistance.

In contrast to chain links cast from steel or machined from plate, the forged alloy possesses an optimized grain-flow orientation. See figure on the left. Forging maximizes performance by putting strength and impact properties where they are needed the most. The structural integrity of the forged links, as well as their higher strength, contributes to longer life and fatigue resistance.

Unlike castings, forged links do not contain internal voids, deleterious inclusions, and other defects that can initiate failure. As a result, service life is estimated to be two to three times that of cast versions, as measured in millions of cubic yards of coal "dragged."



Forged in a series of sequential dies on a counterblow hammer, the dragline chain links delivered mechanical properties and performance that surpass other methods of manufacture. The link is 5.25 in. thick, 50 in. long and 26 in. wide, and it weighs 1375 lbs.

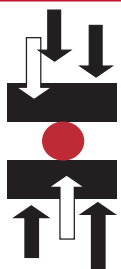
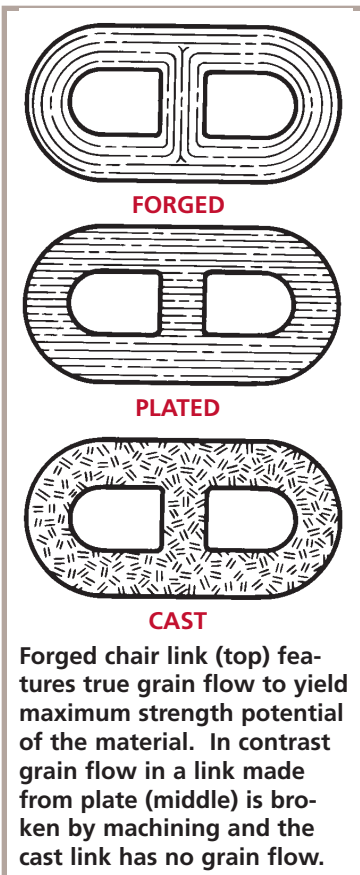

FORGING INDUSTRY ASSOCIATION

25 West Prospect Ave., Suite 300, Cleveland, OH 44115

Phone: 216-781-6260 Fax: 216-781-0102

E-mail: info@forging.org Website: www.forging.org

© Copyright 2007, Forging Industry Association

FORGING SOLUTIONS

Addressing these processes:

Impression Die ✓
Open Die
Rolled Ring
Cold

Design Engineering Information From FIA

CASE STUDY FROM THE FILES:

Precision forging virtually eliminates machining, cuts cost of large structural aircraft part

Manufacturing large aerospace parts can become very expensive when extensive machining is required to bring them to final dimensions. Such was the case with the Boeing 767 front-spar terminal fitting, a major structural component that connects the wing to the body of these commercial aircraft. See top figure on the right.

The machining previously required amounted to removing approximately 75% of the weight of a 120 lb conventional forging. In short, the entire part had to be machined to achieve the specified dimensions and tolerances. Had the component been made as a “hogout,” i.e., fabricated from a hand-forged block, more than 615 lb of aluminum would have had to be machined away from the 645 lb starting stock.

With a significant cost reduction as the driver, the forger was able to make a precision forged part 55-1/2 in. long and with a plan view area (PVA) of 432 sq in. This was made possible by equipping an 8000-ton press with speed and pressure controls.

As a precision forging, the front spar terminal fitting weighs only 29 lb and has a minimum web thickness of 0.260 in., which is thin for such a large-PVA part. In addition, the forger was able to hold tight tolerances throughout the part. Because of the capability to control die deflection, die-closure (thickness) toler-

Continued

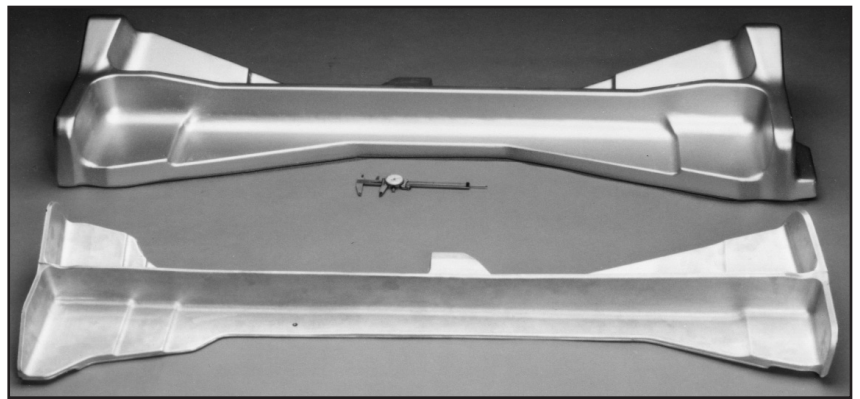

Made from 7175-T74 aluminum alloy, the precision forged terminal fitting (bottom) weighed less than 25% of the conventional forging (top)

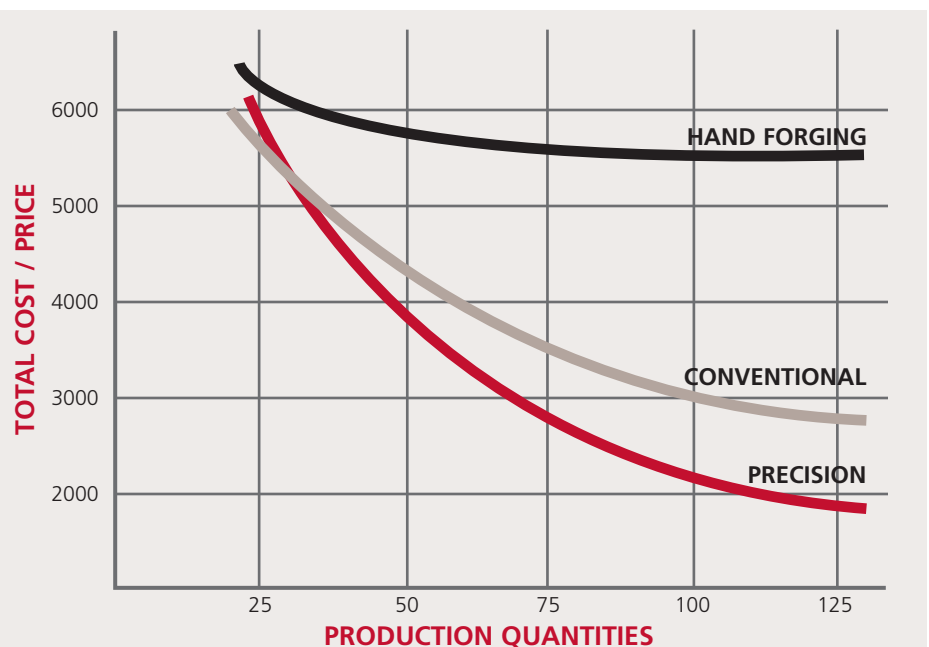

Manufacturing cost analysis showed dramatic cost savings achieved with precision forging versus hogout and conventional forging. The break-even point for the precision forging was less than 40 parts. The cost analysis included amortization of new tooling.

FORGING SOLUTIONS CONTINUED

ances were held to +0.030/-0.010 in., which are tighter than normal for a part of that size. Similarly, length dimensions are held to ± 0.010 in. by performing a simple machining operation on both ends.

Even if certain dimensions and tolerances on a precision component are not practical to forge, or are perhaps too expensive to hold in the forging process, economical options such as machining and chemical-milling can be used on specific part features.

The forger performs the only machining required, which facilitates attachment of mating parts. This value-added service eliminates any machining by the airframe manufacturer, other than merely drilling assembly holes.

Overall, significant cost savings are attributed to precision forging. See bottom figure on page 1. Savings in machining dollars were eight times greater than the increase in cost resulting from the switch from conventional to precision forging. Further, with practically no machining required, production time is considerably reduced.

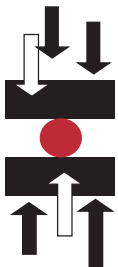

FORGING INDUSTRY ASSOCIATION

25 West Prospect Ave., Suite 300, Cleveland, OH 44115

Phone: 216-781-6260 Fax: 216-781-0102

E-mail: info@forging.org Website: www.forging.org

FORGING SOLUTIONS

Addressing these processes:

Impression Die ✓

Open Die

Rolled Ring

Cold

Design Engineering Information From FIA

CASE STUDY FROM THE FILES:

Forged adapter cuts cost by 50%, resists 2000-psi pressure where casting could not

Not trial and error, but good engineering know-how led to the cost saving design of a forged aluminum adapter for a line of electro-hydraulic rotary actuators. See figure on the right.

The actuators operate valves—butterfly, ball, flood—and other types of rotary devices on command for control of fluid transfer lines in petroleum refining, chemical processing, and related operations. Similar applications include control of industrial ventilation dampers.

The adapters were initially designed as aluminum die castings. This appeared to be the easiest and least costly choice, especially since the manufacturer already had captive die-casting facilities to produce similar components.

Unfortunately, prototype adapters die-cast of 381 and 411 aluminum alloys did not have the internal soundness required. Porosity in the cast parts resulted in leakage of the hydraulic passages and, more important, in a nonfunctioning actuator.

As a stop-gap measure to get actuators built and shipped, adapters were machined from industry-specifications 6061-T6 aluminum plate; but, because of the extensive machining required, overall cost of the finished product was excessive. Consequently, the company considered both forging and permanent-mold casting to reduce manufacturing costs.

Permanent-mold casting of 356 aluminum alloy might have produced less porous products, but quality related uncertainties, and tooling costs at least equal to those of forging, made forging the logical choice.

Forging the adapter from 6061-T6 aluminum proved to be the answer to ensuring part quality and functionality and, at the same time, proved to be much more economical than machining the part from plate. See figure on next page. Not

Continued



The forged adapter had the structural integrity to withstand 2000 psi hydraulic pressures.

FORGING SOLUTIONS CONTINUED

surprisingly, because the forged adapter could be designed closer to net shape than the machined version, it also saved weight.

Further, the structural integrity of forged adapters meant that 100% of these parts are acceptable, versus an overall yield of 15% (85% rejects) for the “best” lot of castings. In fact, one batch of 52 die cast adapters yielded 100% rejects.

Not even considering the high reject rate, the manufacturer decided not to put “acceptable” castings into service because of the possibility that they might fail prematurely and unexpectedly at a later date.

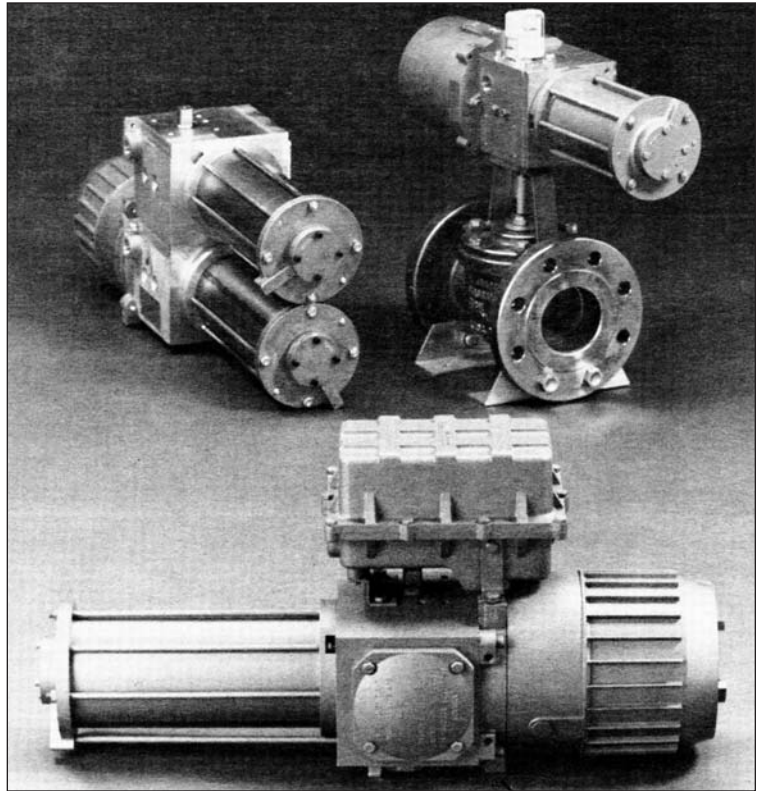

The forged aluminum adapter became an integral, function part of the electro-hydraulic rotary actuator. The adapter was used to mount the hydraulic pump motor, contain the hydraulic reservoir fluid and provide passages for high pressure hydraulic oil.

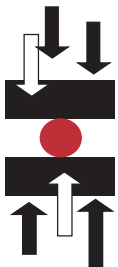

FORGING INDUSTRY ASSOCIATION

25 West Prospect Ave., Suite 300, Cleveland, OH 44115

Phone: 216-781-6260 Fax: 216-781-0102

E-mail: info@forging.org Website: www.forging.org

FORGING SOLUTIONS

Addressing these processes:

Impression Die ✓

Open Die

Rolled Ring

Cold

Design Engineering Information From FIA

CASE STUDY FROM THE FILES:

Slack adjuster outperformed casting, cut weight, achieved optimum 'value-added' design on trucks

A hammer-forged slack adjuster—a mechanical device on truck trailers used to adjust the slack on the braking system—was once conceived as a casting, but strength and impact requirements made forging the logical choice. See figure on the right. With inherent porosity, castings could not meet industry standards for tensile and impact strength required for field life, safety, and reliability.

After the forging was chosen, the manufacturer worked with the forging supplier to improve the original design. The initial design required the drilling of three holes through the thin wall of the forging to insert rivet pins, which were later peened down to attach the cover plate. Even though this fastening method was adequate, hole-drilling and assembly operations were both time-consuming and expensive. The holes also weakened the thin-walled forging. In addition, covers occasionally worked loose.



The forged slack adjuster was made from high carbon steel, which was resulfurized for improved machinability. It contained integral lugs that outperformed both pin riveted and spot-welded assemblies.

Design refinement (a value-added benefit that many forgers can provide) resulted in slack-adjuster bodies that now incorporate six forged lugs. Although not an easy part to forge, the design achieved three major benefits: (1) stronger components, (2) a more secure means of fastening than either riveting or spot welding, and (3) minimal processing and assembly labor. In the end, greater reliability and streamlined production were attained at a competitive cost, thanks to value-added design optimization and close cooperation between customer and forger.

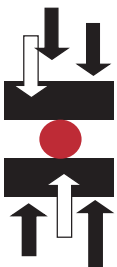

FORGING INDUSTRY ASSOCIATION

25 West Prospect Ave., Suite 300, Cleveland, OH 44115

Phone: 216-781-6260 Fax: 216-781-0102

E-mail: info@forging.org Website: www.forging.org

FORGING SOLUTIONS

Addressing these processes:

Impression Die ✓

Open Die

Rolled Ring

Cold

Design Engineering Information From FIA

CASE STUDY FROM THE FILES:

Forged microalloyed steel crankshaft replaced ADI in high-performance engine

A forged vanadium microalloyed steel crankshaft for a high-performance super charged engine delivered properties that far surpassed those of a conventional nodular-iron crankshaft. See figure on the right.

Although the original design specified ADI (austempered ductile iron), the material was incapable of achieving engineering targets for property consistency and machinability. This traces back to the complexities of melting and casting this material to achieve consistent response in heat treatment.

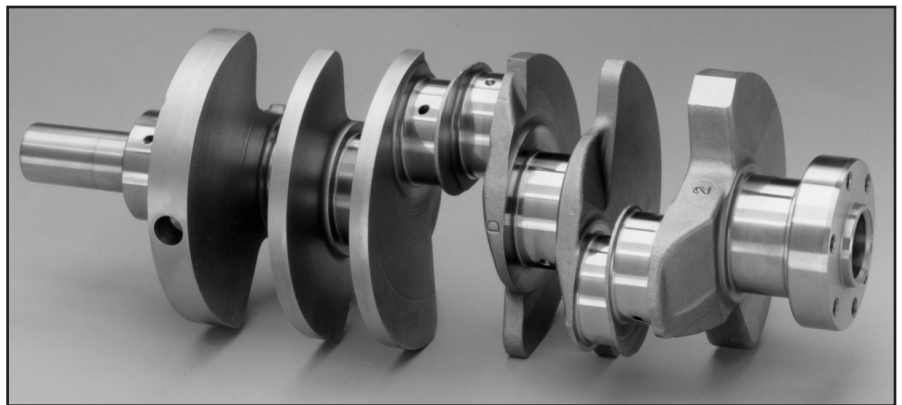

The forged microalloyed steel crankshaft for a supercharged engine outperformed conventional ductile iron cranks.

The best solution to this problem was the selection of a forging, whose strength, modulus, and fatigue properties fulfill higher-performance criteria required. Because a microalloyed steel was selected, properties were achieved “as-forged,” eliminating the expense of quenching and tempering operations that forged carbon-steel cranks routinely require.

Final properties of the microalloyed-steel forgings far surpass those of typical nodular iron. For the forged crank, minimum yield strength is 72,000 versus 55,000 psi for nodular iron; minimum tensile strength, 120,000 versus 85,000 psi. In addition, steel's modulus of elasticity is 30 million psi, compared to a minimum 22 million psi for nodular iron. This higher stiffness further enhances performance under higher in-service stresses. Equally important, fatigue strength of the forged crank (without additional operations to improve fatigue properties in selected areas) is estimated at 55,000 psi, far surpassing that of nodular iron at 32,000 to 35,000 psi.

To further boost fatigue life, engineers opted to use shot-peening and not the usual deep-rolling process to increase fatigue properties on main journals only. The shot-peening performed on all journals (both main and pin) increased fatigue strength by an estimated 30%. Basically, shot-peening of the steel crank's fillets induces compressive stresses (on the surface), which must be overcome before tensile stresses can affect those part areas. Consequently, designers expect longer lives, or no failures whatsoever.

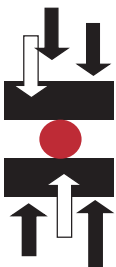

FORGING INDUSTRY ASSOCIATION

25 West Prospect Ave., Suite 300, Cleveland, OH 44115

Phone: 216-781-6260 Fax: 216-781-0102

E-mail: info@forging.org Website: www.forging.org

© Copyright 2007, Forging Industry Association

FORGING SOLUTIONS

Addressing these processes:

Impression Die ✓

Open Die

Rolled Ring

Cold

Design Engineering Information From FIA

CASE STUDY FROM THE FILES:

Ready-to-assemble, forged steering arm replaced weldment

Automobile manufacturers have moved toward fabricated assembly parts with the goal of cost reduction in mind. A good example of this trend was a multicomponent suspension assembly, consisting of two stampings and a screw-machine part. These three were then welded together to form the steering arm. See figure on the right.

Although stampings were considered inexpensive, extensive labor was required to assemble and weld the components. Unfortunately, the weldment's reliability was below par, as indicated by quality problems and assemblies that continually failed under test. In addition, the three-part weldment never attained manufacturing-cost goals.

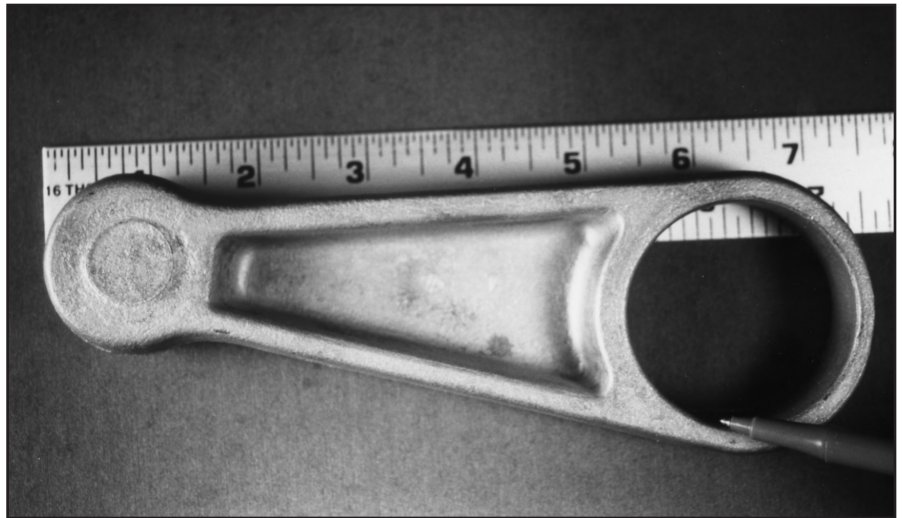

The forged steering arm not only was stronger than the welded assembly but also had reduced weight. The large hole was parallel pierced through the part thickness to maintain straightness and reduce subsequent machining operations.

To solve the performance problems, a creative forger redesigned the steering arm as a carbon-steel hot forging, which would provide the high strength, structural integrity and reliability required. From the customer's viewpoint, however, the retooling cost required for machining the heat treated forging was prohibitive. Refining the concept, the forger then proposed supplying an impression-die hot forging in the finished condition.

After forging, a coining operation brought the part closer to final dimensions, thereby minimizing subsequent machining operations. By outsourcing final machining, heat-treating, and painting operations, the forger was able to provide a ready-to-assemble product. This full-service approach relieved the customer of the burden of performing extensive and expensive finishing operations and contributed significantly to cost savings. The lighter, more reliable forging also helped to achieve two important customer goals: increasing mileage ratings and improving quality through longer-service-life parts.

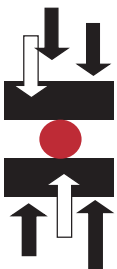

FORGING INDUSTRY ASSOCIATION

25 West Prospect Ave., Suite 300, Cleveland, OH 44115

Phone: 216-781-6260 Fax: 216-781-0102

E-mail: info@forging.org Website: www.forging.org

© Copyright 2007, Forging Industry Association

FORGING SOLUTIONS

Addressing these processes:

Impression Die	✓
Open Die	✓
Rolled Ring	✓
Cold	✓

Design Engineering Information From FIA

CASE STUDY FROM THE FILES:

Forged tube support replaced bar stock, eliminated all machining and cuts cost by 85%

In a concerted effort to reduce costs of its metal components, a major manufacturer of medium- and heavy-duty industrial and agricultural equipment worked closely with a local forging company to redesign a machined bar stock component as a more cost-effective forging. After conversion, the results were better than expected, for a simply configured, volume-sensitive component. The steel forging cost less than one-sixth that of machined bar stock.

Previously, four different operations were required to produce the part. First, a long piece of 1020 hot-rolled bar was cut in two, then flame cut, ground, and was finally placed into a lathe fixture where the bottom was turned. By making it a forging, the company was able to produce it close enough to net shape to eliminate all machining operations—a reduction from four in-plant operations down to none. See top figure. As received from the forger, the components were directly installed on the equipment. See bottom figure.

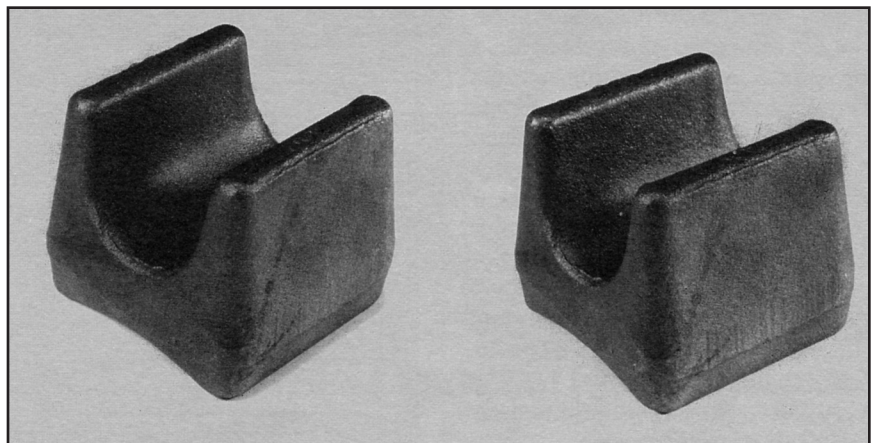

The as forged steel tube support was ready for assembly, as compared to the bar stock version, which required extensive machining.

COST ANALYSIS FOR STEEL TUBE SUPPORT

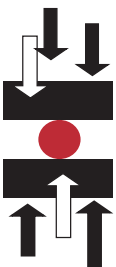
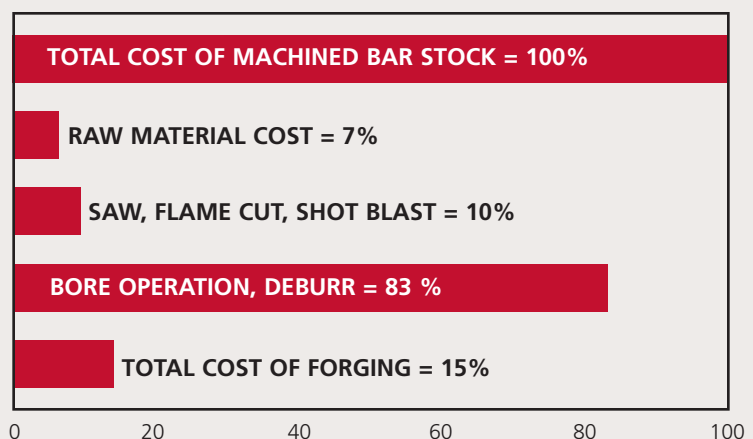

FORGING INDUSTRY ASSOCIATION

25 West Prospect Ave., Suite 300, Cleveland, OH 44115

Phone: 216-781-6260 Fax: 216-781-0102

E-mail: info@forging.org Website: www.forging.org

© Copyright 2007, Forging Industry Association

FORGING SOLUTIONS

Addressing these processes:

Impression Die	✓
Open Die	
Rolled Ring	
Cold	✓

Design Engineering Information From FIA

CASE STUDY FROM THE FILES:

CVJ 'tulip' finished as-forged, cut cost and eliminated expensive machining operations

Due to the refinement of the forging process, a critical component of a CVJ (constant velocity joint) for front-wheel-drive systems became more cost-effective and more efficiently made. The "tulip" features a sliding joint that accommodates the ups and downs of the suspension and the steering gears' turns while simultaneously transmitting power to the wheels. See figure.

Previously hot forged and subsequently machined, the tulip required very difficult machining. Not only did the three tracks require turning and grinding, but the trimming operation also involved interrupted cuts. This resulted in high tool wear and made it very difficult to attain the accuracy required. While the grinding operation was necessary to achieve the desired surface finish, it also created another potential problem: distortion upon subsequent induction hardening.

By switching to warm forging (actually warm extrusion at about 1200° F) the number of operations to machine the tulip were significantly reduced. After warm forming and just prior to cooling, the component was coined or sized to its final form, and then induction hardened. Since all cutting, grinding, and turning were eliminated, the resulting cost savings was considerable.

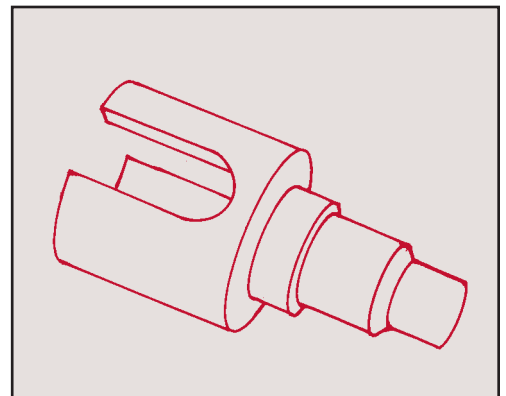

The steel "tulip" is finished as formed. No machining is necessary on the internal contours.

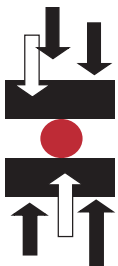

FORGING INDUSTRY ASSOCIATION

25 West Prospect Ave., Suite 300, Cleveland, OH 44115

Phone: 216-781-6260 Fax: 216-781-0102

E-mail: info@forging.org Website: www.forging.org

© Copyright 2007, Forging Industry Association

FORGING SOLUTIONS

Addressing these processes:

Impression Die	✓
Open Die	✓
Rolled Ring	✓
Cold	✓

Design Engineering Information From FIA

CASE STUDY FROM THE FILES:

Capability analysis brought process into control, boosted quality of forged automotive parts

Capability studies are powerful tools in controlling the forging process. In this example (relatively high volume aluminum die forgings), too many automotive parts were being produced outside the specification range. Although practically all parts could be reworked to bring them within the blueprint tolerance range, adjusting the process should theoretically produce all parts to specification.

To analyze the situation, engineers conducted a capability study using

the die closure dimension (thickness), which is normally the dimension of interest for evaluating how well the process is "in control." If this dimension is correct, so are all other dimensions.

Initial capability analysis showed that the spread was too wide for the specification, and that the process was off center, as indicated by a low process capability index or C_{pk} . By definition, C_{pk} = specification tolerance range divided by $\pm 3\sigma$ of the process capability range. A process capability index, C_{pk} , of greater than 1.33 means that more than 99.94% of the forged products are within the specified blueprint tolerance.

Adjusting specific process variables brought the process back into control, achieving a C_{pk} of 1.3820 versus the initial value of 0.0123. See table. The adjustments also brought the mean value much closer to center. See figure above. Consequently, all parts produced after process adjustment fell within the specification limits. Rework dropped from 49% to 0.

Other benefits included not only reduced inspection, but also the elimination of part sorting and restriking or oth-

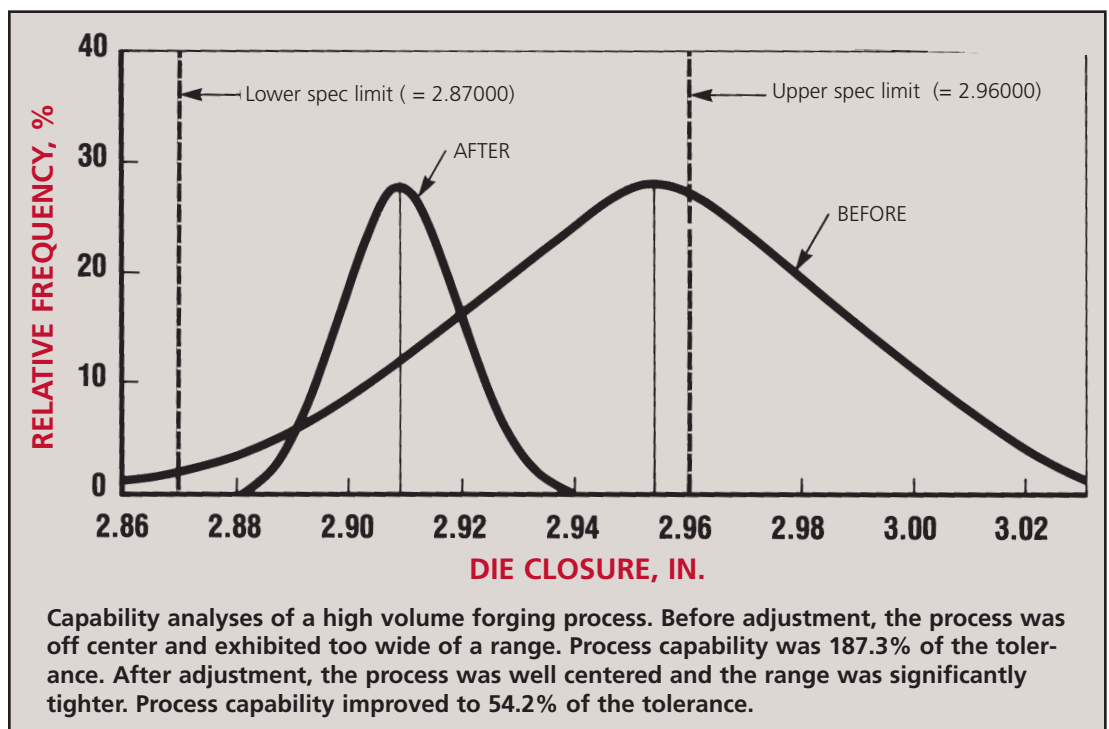

FORGING SOLUTIONS CONTINUED

erwise reworking parts to make them acceptable. Correspondingly, productivity and cost effectiveness also increased.

Finally, once the process was centered with a relatively high C_{pk} , it was relatively simple to maintain. Only statistical sampling and plotting of control chart points were necessary to monitor production. Once a process is adjusted, it tends to stay "in control."

PROCESS CAPABILITY PARAMETERS

Parameter	Before	After
Mean	2.9543	2.9085
Std. dev.	0.0281	0.0081
% < L.S.L.	0.89	0.0000
% > U.S.L.	48.8	0.0000
C_{pk}	0.0123	1.3820
Process capability, % of blueprint tolerance:	187.3	54.2
Specification limits		
(L.S.L. - U.S.L.)	2.870-2.960	
3 σ limits (Before)	2.870-3.039	
3 σ limits (After)	2.884-2.933	
4 σ limits (Before)	2.842-3.067	
4 σ limits (After)	2.876-2.941	

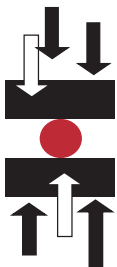

FORGING INDUSTRY ASSOCIATION

25 West Prospect Ave., Suite 300, Cleveland, OH 44115
Phone: 216-781-6260 Fax: 216-781-0102
E-mail: info@forging.org Website: www.forging.org

FORGING SOLUTIONS

Addressing these processes:

Impression Die	✓
Open Die	
Rolled Ring	
Cold	✓

Design Engineering Information From FIA

CASE STUDY FROM THE FILES:

Co-operative redesign delivered forged stop nut, eliminated machining, and consolidated parts

Because of cooperative engineering between a forging company and customer, a stop nut for a pipeline ball valve was redesigned as a steel forging. See figure. Significant cost savings was achieved as a result of part consolidation and elimination of virtually all machining operations. The successful design was then adopted for the entire family of parts.

With a basically square configuration, the stop nut fits on the stem of a ball valve and indicates the direction of flow. Its square shape allows it to be used in conjunction with an actuator or a tool to open and close the ball valve on cross-country pipelines that carry oil, gas, petroleum products, and other liquids and gases.

Originally made from square stock, the old design required extensive machining, including turning, milling and broaching a spline on the internal diameter. A two-piece cap, consisting of a round component and a pointer (to indicate flow direction) was then assembled with two hex-head cap screws and washers.

To eliminate expensive machining and reduce the number of components, a cold forging was designed that featured a blind spline and an integral cap with pointer—all in one piece. After cold forging the square stock with multiple "strikes," the only additional operation required was drilling a hole in the top. The customer then stocked the forging as a finished part.

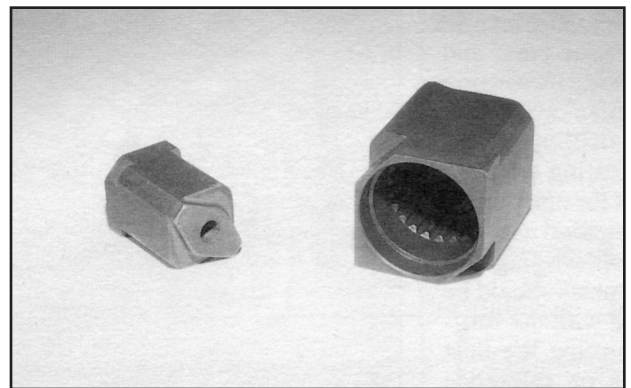

A one-piece multifunctional stop nut replaced machined bar stock and additional components.

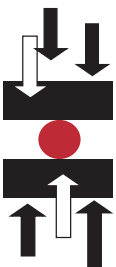

FORGING INDUSTRY ASSOCIATION

25 West Prospect Ave., Suite 300, Cleveland, OH 44115

Phone: 216-781-6260 Fax: 216-781-0102

E-mail: info@forging.org Website: www.forging.org

© Copyright 2007, Forging Industry Association

FORGING SOLUTIONS

Addressing these processes:

Impression Die ✓

Open Die

Rolled Ring

Cold

Design Engineering Information From FIA

CASE STUDY FROM THE FILES:

Redesign plus teamwork produced a forged part, saving 80% in material cost over casting

As part of a comprehensive, cooperative redesign program between a major agricultural/industrial equipment manufacturer and a local forging company, parts for hydraulic cylinders that were once castings are currently much less expensive as higher-performance steel forgings. In one instance, a redesigned port achieved a total cost reduction of 53%, comprised of an 85% reduction in material cost alone (based on the costs of the as-received forging and as-received casting) combined with more than a 50% reduction in machining. See figure. A similar part showed greater than an 80% reduction in material cost and the balance in machining savings, as a milling operation was completely eliminated.

Even where no labor savings was evident, over 50% total savings was typical. Added benefits attributed to the forged design included higher performance, significantly lower scrap, and elimination of testing. When these parts were made as castings, hundreds (of each model) were returned to the foundry each year because of porosity and other problems. With the forged versions, which can easily withstand 4000 psi pressure that the design requires, the reported scrap rate is less than 0.1%. Additionally, many of the cast parts had to be 100% inspected. This expense was virtually nonexistent with forgings.

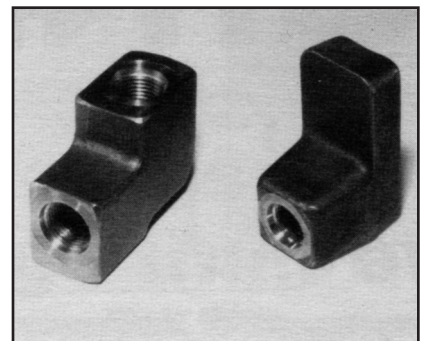

Close cooperation between the forger and manufacturer resulted in a cost effective port design.

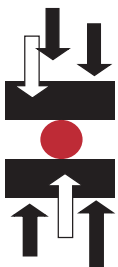

FORGING INDUSTRY ASSOCIATION

25 West Prospect Ave., Suite 300, Cleveland, OH 44115

Phone: 216-781-6260 Fax: 216-781-0102

E-mail: info@forging.org Website: www.forging.org

© Copyright 2007, Forging Industry Association

FORGING SOLUTIONS

Addressing these processes:

Impression Die ✓

Open Die

Rolled Ring

Cold

Design Engineering Information From FIA

CASE STUDY FROM THE FILES:

Forged-microalloyed yoke for driveline delivered net savings plus increased performance

Many yokes have been switched from heat treated grades to microalloyed steels, as a means to reduce costs. One example is a driveline yoke.

Previously made from 1141 resulfurized steel, the part—a weld yoke for the driveshaft of a heavy-duty truck—was normalized prior to machining, then quenched and tempered (Q&T) to attain the required properties. To reduce costs, the manufacturer opted for a microalloy steel forgings. Through cooperative development with the forger and steel suppliers, the end-user selected an 11V41 microalloy steel, a resulfurized 1141 steel with vanadium added, that permitted final properties to be achieved "as-forged," i.e., without post-forging heat treatment. See figure on the right.

Switching to the microalloy eliminated normalizing and Q&T operations, allowing the component to be machined as-forged, then welded and assembled. The properties achieved (86 ksi yield strength and hardness of 169 BHN) were equivalent to the Q&T counterpart, except for lower notch toughness, which was not a concern for the application. Forced-air cooling on a conveyor produced the desired microstructure: a fine-grained pearlite with grain-boundary ferrite.

In order to simulate in-service conditions, the customer put the MA forging through torsion testing on a driveshaft, continually reversing the shaft for the same number of cycles required for Q&T parts. The microalloy forgings exceeded all test criteria. Machinability testing also yielded good results.

Net cost savings was estimated to be at least \$0.10/lb. per part, taking into account the increase in material cost and the reduction in heat treating cost.



The forged 11V41 microalloyed steel, 11 lb. yoke for a truck drive shaft delivered significant cost savings.

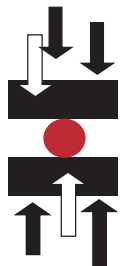

FORGING INDUSTRY ASSOCIATION

25 West Prospect Ave., Suite 300, Cleveland, OH 44115

Phone: 216-781-6260 Fax: 216-781-0102

E-mail: info@forging.org Website: www.forging.org

© Copyright 2007, Forging Industry Association

FORGING SOLUTIONS

Addressing these processes:

Impression Die	✓
Open Die	✓
Rolled Ring	✓
Cold	✓

Design Engineering Information From FIA

CASE STUDY FROM THE FILES:

Forged aluminum ejector cut cost, provided critical dimensions

Forged from 2014 aluminum alloy, an ice-cube ejector for refrigerators held up where cast, powder metal, and plastic components just could not perform. The 1 oz. forging provided the required strength and critical dimensions needed to mesh with mating parts and function without water leaking, which would stop the icemaker from operating.

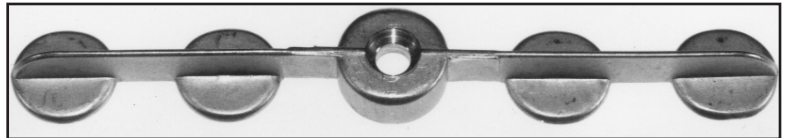

Approximately 5.5 in. long, the impression die forge aluminum ejector has performed well in refrigerators.

In the interest of cost savings, the manufacturer explored non-forging options. If water leaked and froze, the casting snapped in half under pressure when trying to push down and eject the ice cubes. It was the same result with both the powder metal (PM) and plastic versions. Although plastic and PM parts cost less initially, continual replacement of parts in the field was an extremely costly option and a short-lived one. The OEM certainly did not want its reputation tarnished. Forgings provided superior strength and unmatched service life. According to the forger, life cycle cost savings were significant.

Conventionally forged from 6 in. sections cut from 1 in. diameter 12 ft. long rods, the aluminum ejector was forged two at a time to maintain size and maximize die life. See figure. Flash was removed by clipping and, at the same time, a shaving operation was performed on the web thickness. The parts were then solution heat treated and aged to provide the required in-service strength and proper hardness for machining. Next, the forging went into an automatically fed saw that made two parts from one forging. Prior to vibratory deburring, parts were gauged to ensure straightness and thickness from one end of the part to another. After drilling and counter-boring of the center hole, the parts were clear anodized for additional corrosion resistance.

For proper function, the ejector had to meet stringent engineering specification, including a number of critical dimensions. For example, the pad diameters had to be accurate to prevent leading water and restriction of ejector movement. For the center pad, diameter was held to 0.798 to 0.810 in.

Web thickness also was critical in meeting assembly tolerances for mating parts. Essentially, the draft was shaved off, creating a straight wall. Excess thickness (0.095 to 0.085 in., as forged) was reduced to 0.085 in.

Even though dimensional tolerance of the forge was considered minimal for this part, secondary operations like shaving and automatic sawing hold critical dimensions to the close tolerances required.

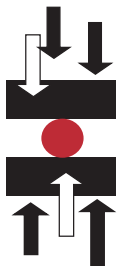

FORGING INDUSTRY ASSOCIATION

25 West Prospect Ave., Suite 300, Cleveland, OH 44115

Phone: 216-781-6260 Fax: 216-781-0102

E-mail: info@forging.org Website: www.forging.org

© Copyright 2007, Forging Industry Association

FORGING SOLUTIONS

Addressing these processes:

Impression Die ✓

Open Die

Rolled Ring

Cold

Design Engineering Information From FIA

CASE STUDY FROM THE FILES:

Forging techniques made steel cam cost-effective for high-volume production

In the past, forged-steel roller camshafts were not cost-effective for two reasons: 1) an extensive amount of material was required to provide proper flashing of the cam; and 2) extensive machining was required to adequately "clean up" the heavy machine stock.

To produce a more competitive steel camshaft for high-stress roller lifter applications, an innovative forging company and a major automaker teamed up and developed a new camshaft. The net result included a

reduction in capital investment (for rough machining) of 70%. The increase in machining productivity also allowed the customer to reduce overall labor costs by 50%. See figure. Not unexpectedly, the new production rates put forging on a par with cast-iron cams, but also added the benefit of superior performance, which leads to reduced life-cycle costs. Along with delivering impressive savings, the cam virtually eliminated camshaft warranty problems, which previously was an area of concern.

Making the cam in two sections (main shaft and larger hub), then friction welding the two parts together eliminated much of the previous machining waste. Additionally, a precision preform for the main shaft, made by cross-roll forming, was utilized prior to press forging the lobes. The shorter shaft length (i.e., without the flange) also allowed two cam preforms to be made in one rolling operation. The companies also opted for post-grind hardening through induction heating, rather than the conventional grinding of pre-hardened material.

Compared to traditional forging methods, these techniques created a variety of cost savings. Total material loss in forging was reduced by over 50%. Lower forging pressure also reduced die costs, while costs of rough-machining equipment dropped due to the smaller stock size.



Approximately 15.5 in. long with a 3.75 in. hub diameter, the forged 5150 steel camshaft was used on a fuel injected 3.8 L engine.

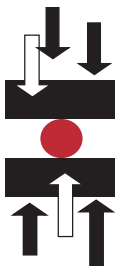

FORGING INDUSTRY ASSOCIATION

25 West Prospect Ave., Suite 300, Cleveland, OH 44115

Phone: 216-781-6260 Fax: 216-781-0102

E-mail: info@forging.org Website: www.forging.org

FORGING SOLUTIONS

Addressing these processes:

Impression Die ✓

Open Die

Rolled Ring

Cold

Design Engineering Information From FIA

CASE STUDY FROM THE FILES:

Forged microalloyed steel engine mount cut cost, outperformed alternatives

A forged microalloyed steel engine mount replaced a design stage casting and delivered a cost savings of 10% over a quenched-and-tempered steel forging. See figure.

Classified as a structural automotive component, the forged component was selected over a casting because it reduced weight, optimized strength and delivered superior strength. Improved reliability was also a deciding factor.

Unusual in shape, the asymmetrical part was not only a difficult part to design, but also a challenge to forge because of its unique configuration and parting-line location.

The 5 lb. part, which was made of a 10V45 microalloy steel, was impression-die forged, then air cooled via conveyor to achieve the required properties (see table). After forging, cold coining was utilized to bring the forging closer to final dimensions and to maintain critical complex angles, so that bolt holes aligned with those on the engine. Prior to shipping, the forging company performed value-added operations, including machining, painting, and packaging.



The forged microalloyed steel engine mount has a complex geometry. It provided the required property profile using a ferrite pearlite microstructure.

PROPERTIES OF FORGED 10V45 ENGINE MOUNT

Property	Test 1	Test 2
Tensile strength, psi	127,560	128,050
Yield strength, psi	78,000	78,960
Elongation,	13	14
Red. of area, %	17	21
Hardness, BHN	255	255

Chemical composition

C	Si	Mn	P	S
0.44	0.20	0.83	0.008	0.03
Cr	N	Mo	V	
0.07	0.06	0.01	0.11	

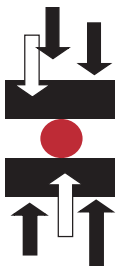

FORGING INDUSTRY ASSOCIATION

25 West Prospect Ave., Suite 300, Cleveland, OH 44115

Phone: 216-781-6260 Fax: 216-781-0102

E-mail: info@forging.org Website: www.forging.org

FORGING SOLUTIONS

Addressing these processes:

Impression Die ✓

Open Die

Rolled Ring

Cold

Design Engineering Information From FIA

CASE STUDY FROM THE FILES:

Forged track links perform, thanks to harden-and-temper + induction

Track links can be used in a variety of construction equipment because they are made of forged, heat-treated steel. Forging is the only manufacturing method that can produce properties to meet design requirements.

The track links, used in track chain on bulldozers, excavators and loaders, possess the superior fatigue life characteristic of hardened-and-tempered steel forgings, as well as the static strength required to retain press-fits of pins and bushings.

Forging provided high hardness and, wear resistance via induction hardening in the rail section of the component, while retaining a sufficiently low hardness in the main body of the component to provide good impact and fracture toughness.

The steel was a C/Mn/B grade, which provided sufficient hardenability to produce high strength and toughness throughout the cross-section of the forging.

Heat treatment was the key to meeting property requirements. After impression die forging, the links were austenitized at 1560°F, quenched in a water-based media, and then tempered (about 1/2 hr at 400°F) to a hardness in the HRC mid-30 range. The parts were then machined. The rail section was induction hardened to a hardness level in the HRC mid-50 range for wear resistance. See figure.



The hardened and tempered track link featured an induction hardened rail section (at the bottom of the part) that provided higher wear resistance.

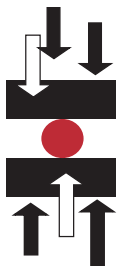

FORGING INDUSTRY ASSOCIATION

25 West Prospect Ave., Suite 300, Cleveland, OH 44115

Phone: 216-781-6260 Fax: 216-781-0102

E-mail: info@forging.org Website: www.forging.org

FORGING SOLUTIONS

Addressing these processes:

Impression Die ✓

Open Die

Rolled Ring

Cold

Design Engineering Information From FIA

CASE STUDY FROM THE FILES:

Forging replaced casting in friction-welded assembly, cut cost by streamlining manufacturing operations

By upgrading to a forging from a casting, an OEM of agricultural and construction equipment was able to more easily friction weld a shaft to a rod end, which was a key part of hydraulic cylinders for heavy-duty equipment. Essentially, use of a forging allowed the company to take two basically raw parts and put them together at a substantial cost savings. See figure.

In the past, the manufacturer had to core drill the steel casting, bore it, then face the end of it off prior to friction welding. Additionally, heat generated during welding significantly distorted the eye of the rod end, causing dimensional problems for a subsequently installed bushing.

Fortunately, the eye in the forged component could be hot pierced during forging and still maintained sufficient perpendicularity so that only a broaching operation was needed. The as-forged surface was then friction welded against a saw-cut shaft. The forging not only provided better dimensional control (compared to recurring shrinkage problems with the casting), but also eliminated distortion of the eye; no more egg shapes as with cast predecessors.

Overall, total savings amounted to 72%, consisting of a 76% cost cut in machining operations and a 69% cut in material cost (as-supplied forging versus as-supplied casting).



Forged from 1045 steel, the rod end needed only an inexpensive broaching operation prior to being friction welded to a shaft.

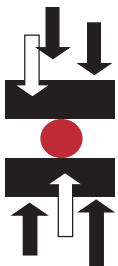

FORGING INDUSTRY ASSOCIATION

25 West Prospect Ave., Suite 300, Cleveland, OH 44115

Phone: 216-781-6260 Fax: 216-781-0102

E-mail: info@forging.org Website: www.forging.org

© Copyright 2007, Forging Industry Association