

**FORGING SOLUTIONS**  
**Design Engineering Information From FIA**

**ROLLED RING – ARTICLES**

**TABLE OF CONTENTS**

*Forged Grain Flow Boosts Fatigue Life*

*Structural Integrity Extends Design Limits of Forged Parts*

*Ten Ways that Forgings Help to Reduce Costs*

*Improved Alloys Boost Quality and Economy of Forged Components*

*Value-added Forgings Offer Design Options for Ready-to-Install Parts*

*Forging Size Plus Shape Capability Expands Metal Design Options*

*The Best Answer to the Cost/Performance Question*

*Continuous Improvement Helps Forgings Deliver Optimum Quality*

*Co-Engineered Forgings*

*Forgings Superior to Castings Due to Long-term Performance*

*Forged Rings: The Ultimate in Integrity and Properties*

*Forging Fundamentals: The Key to Optimum Design Practice*

*Design for Forgings-Specifications Help*

*The Language of Forging: Key Terms and Definitions*

# FORGING SOLUTIONS

Addressing these processes:

Impression Die	✓
Open Die	✓
Rolled Ring	✓
Cold	✓

Design Engineering Information From FIA

## FORGED GRAIN FLOW BOOSTS FATIGUE LIFE

Greatly improved fatigue life and impact strength in aerospace, automotive and other industrial applications, along with higher strength in thinner sections (which directly results in lighter parts), are the reasons why emphasis is placed on optimizing grain flow in forged components.

Orienting the grain structure can enhance mechanical properties, boosting service life several times. This provides one of the intrinsic benefits of forgings. Typical examples of these benefits include:

- *Six to ten times greater impact fatigue life* in precision-forged straight bevel gears and 100% to 300% better fatigue life in near-net-shape spiral bevel gears add up to longer lasting drive-train components in heavy trucks, construction, marine and agricultural equipment, as compared to standard “cut” steel gears. Optimum grain flow patterns in forged, net teeth make these performance increases possible.
- *Higher strength in reduced cross-sections* is achieved in forged truck and passenger car wheels, because controlled grain flow in the flange area puts the strength where it is needed. When compared to cast wheels, forged wheels save material, cut weight, and more easily meet mileage requirements.
- *Improved performance and cost effectiveness* are routinely achieved in structural aircraft and aerospace components, including many with large plan-view areas. Control of grain flow in precision aluminum forgings makes components stronger in several directions, permitting weight savings and facilitating part consolidation. Extensive labor savings are a major benefit over weldments and built-up composite structures.

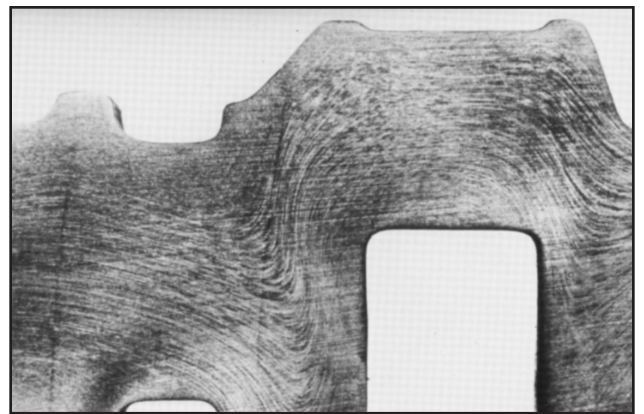

Etched surface of sectioned crankshaft reveals "classic" grain flow pattern that gives forged parts their strength.

### Pushing performance

Orientation of grain flow—alignment of the metal microstructure with the geometry of the part being forged—is directly responsible for developing maximum tensile strength, toughness (impact strength), fatigue resistance and, ultimately, the greater service-life expectancy that is characteristic of forged net-shaped parts.

No other metalworking components (including castings, machined bars and plates, weldments, and other fabricated assemblies) permit this degree of grain control and subsequent property enhancement. In castings, grain flow cannot be optimized since grain direction is characteristically random as a result of the solidification process. Similarly, machined components exhibit discontinuous grain flow. Because of extensive metal removal, grains are broken at the part surface, and the surface is where failure usually initiates. At best, grain orientation in machined parts is unidirectional, taking on the prior patterns of the original bar, billet, or plate.

Continued

# FORGING SOLUTIONS CONTINUED

“Classical” grain flow follows the contour of a forged part, as is characteristic of a forged crankshaft. However, certain geometries and performance requirements may benefit from a different type of grain flow. For example, circumferential-type hoop strength or strength in the axial direction may be needed, depending on the part geometry and stresses that the part will see in service. What can be accomplished in terms of grain flow is also dependent on the forging techniques and tooling utilized, both of which can affect cost as well as ultimate part performance.

In rib- and web-type forgings, longitudinal grain flow (the strongest orientation in terms of properties) coincides with the primary grain direction of the starting billet. This initial orientation is created by deformation during stock fabrication, which typically elongates the grains in a direction parallel to the primary working direction. Further working by closed-die forging modifies and refines the starting-billet grain structure to produce the best combination of properties in all test directions.

In most forgings, the initial grain flow direction (longitudinal and the strongest) is oriented within the part along the axis that will see the highest in-service loads. However, grain-flow modifications made by judicious use of tooling and forging techniques can be utilized to maximize strength in other directions without sacrificing properties along the principal direction.

## Grain-flow sensitivity

Some metals and alloys exhibit a “grain-flow sensitivity,” which is reflected by the degree of isotropy of the material being forged. Materials with high grain-flow sensitivity exhibit greater differences in properties between the longitudinal and transverse grain-flow directions. (This does not imply that forgings are strong in only one direction, since tests show that properties in any direction usually exceed those of non-wrought products, like castings.) The table below lists various metals according to their grain-flow sensitivity.

Grain-flow patterns can be controlled to a far greater extent in aluminum and other alloy precision forgings than in parts conventionally forged between two-piece upper and lower dies, due to the use of multi-segment dies. This type of tooling is standard for aluminum and some other alloy precision parts, and it creates controlled paths for the material to flow into several regions of the die cavity or into gutter areas surrounding the cavity. As with conventional forgings, additional modifications to grain direction can be achieved by the use of bending or preforming dies prior to blocking and finishing.

*Continued*

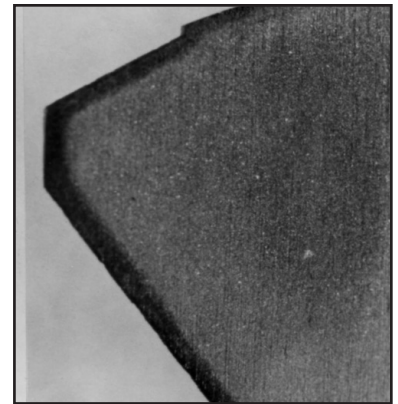

Grain flow that follows the contour of forged teeth in steel bevel gears is directly responsible for improvements in fatigue life over machined gears.

### Grain-flow sensitivity is a function of material

Depending on the type of metal or alloy and its microstructural characteristics, grain-flow sensitivity - reflected in the degree of anisotropy or property directionality - can vary widely. This dependence should be taken into account in forging design.

#### **Least sensitive**

*Pure metals:* aluminum, nickel, cobalt, silver and copper.

*Solid-state alloys:* nickel/copper and aluminum/copper alloys.

#### **Moderate sensitivity**

*Precipitation-hardenable alloys:* 300 series stainless steels, magnesium alloys, and nickel/chromium alloys.

*Steels:* carbon and alloy; 400 Series stainless.

#### **High sensitivity**

*Two-phase alloys:* Most high-strength aluminum alloys, 2014, 7075, 7079, etc.; many nickel and cobalt-based superalloys including INCO 718, Waspalloy and Astroloy.

*Two-phase alloys (not fully recrystallized):* Titanium alloys like Ti-6Al-4V; certain alloys of zirconium, molybdenum alloys like Mo-Ti-Zr.

# FORGING SOLUTIONS CONTINUED

## Two-way street

Proper development of grain-flow patterns, along with the ultimate property profile, can only be achieved by good communication between the design engineer and the forger. It is this two-way communication that facilitates a truly effective cost/performance balance.

Key to this balance is specifying grain-flow requirements only where they are absolutely necessary. In practice, only a few areas of a forging require optimum grain flow, and most non-critical areas are subject to considerably lower stresses. Highly stressed areas (aptly named "hotspots") can readily be identified by determining the failure mode.

Such analysis helps to avoid over-specifying grain flow, which increase costs. In many cases, optimum grain flow (hence, optimum properties for a particular component) is achieved by employing one or more clocker dies, and then finish dies. Conversely, multiple dies cannot improve the grain flow of some designs, and specifying a blocker operation merely increases the tooling cost. It always pays to discuss final component application with the forger in order to determine how best to optimize grain flow while simultaneously keeping tooling and production costs down.

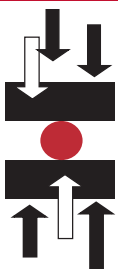
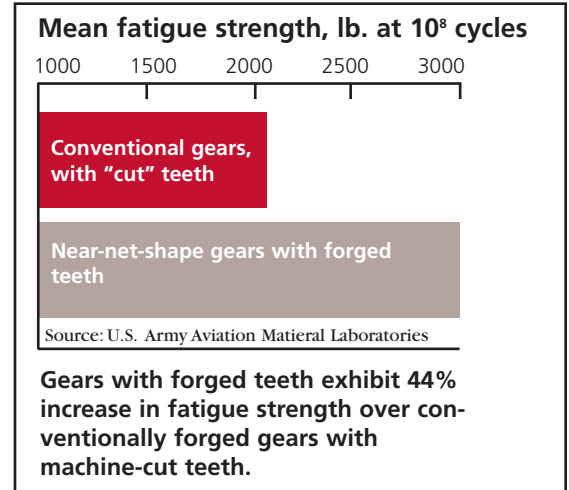

## FORGING INDUSTRY ASSOCIATION

25 West Prospect Ave., Suite 300, Cleveland, OH 44115

Phone: 216-781-6260 Fax: 216-781-0102

E-mail: [info@forging.org](mailto:info@forging.org) Website: [www.forging.org](http://www.forging.org)

# FORGING SOLUTIONS

Addressing these processes:

- Impression Die ✓
- Open Die ✓
- Rolled Ring ✓
- Cold ✓

Design Engineering Information From FIA

## STRUCTURAL INTEGRITY EXTENDS DESIGN LIMITS OF FORGED PARTS

Design engineers routinely find they can take greater advantage of the ultimate property values of forgings, as compared to metal components fabricated by other processes. This means that forgings can be lighter and smaller. Depending on the application, designs for forged components can be based on 75 to 80% of the yield strength, for instance. Not surprisingly, this design percentage is considerably lower for castings.

A specific example is the use of forgings with a high tensile strength in industrial dryers and rotary kilns, permitting the use of design limits that are 36% higher than castings. Similarly, forged gears can be designed to withstand higher stresses. Structural integrity, overall quality, higher strength, and the consistent properties of forgings place them above castings and components produced by other metalworking processes. The inherent soundness of forged components is reflected in their structural, metallurgical, and dimensional characteristics. Consequently, where metal components are concerned, forgings are the first choice for many applications, ranging from high-speed gears to critical aerospace components.

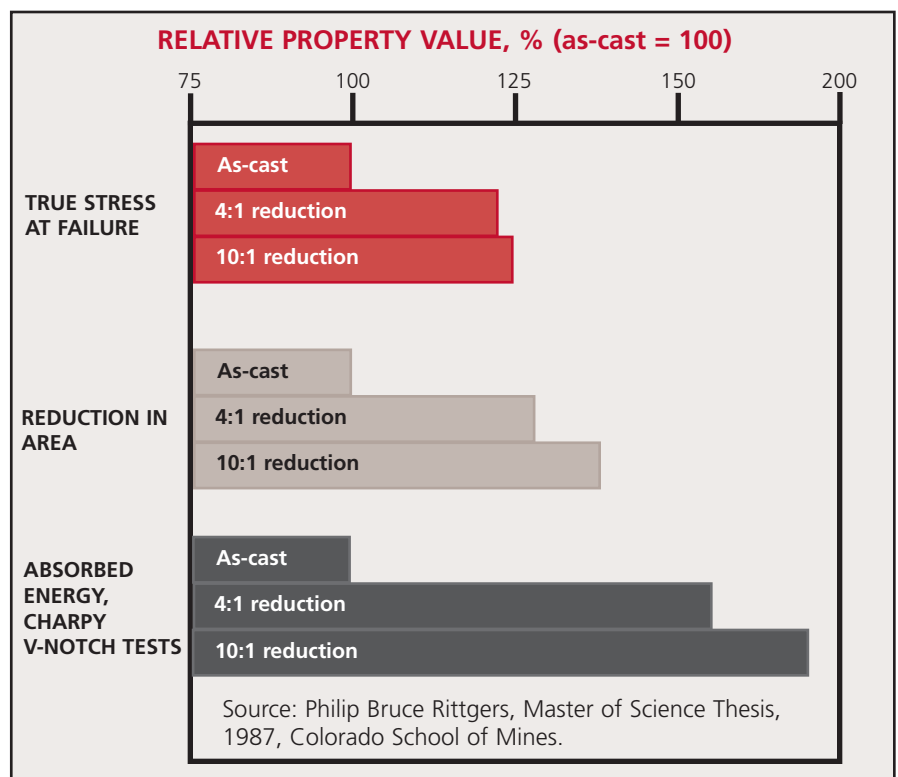

Hot-work reduction, as is characteristic of hot forging, produces significant mechanical property improvements versus as cast steels. Data are for quenched and tempered 4140 steel.

### Reliability via strength

When it comes to strength, the reputation that forgings possess is well deserved. Significantly higher property values for forged versus cast steel are dramatically depicted in the bar chart above. Through the reduction achieved in the forging process and the accompanying homogeneous microstructure, forged components consistently attain higher strength levels than castings and metal parts made by other methods. Even when transverse properties are increased to equal longitudinal property values via an upsetting operation prior to conventional forging, tensile properties and fatigue limits surpass those of competitive fabrication methods. Similarly, the corresponding toughness and ductility

*Continued*

# FORGING SOLUTIONS CONTINUED

achievable in forging surpass all other metalworking processes.

As frequency distributions for selected properties aptly demonstrate, the higher strength and ductility (indicated by reduction of area) of forged steel translate into higher reliability. See figure on the right. Similarly, the high ductility of forgings contributes an extra safety margin, should unexpected peak loads exceed the design-stress calculations. In addition, the much greater strength-to-weight ratio of forgings facilitates the design of lighter-weight parts with corresponding cost savings, and without sacrificing safety.

## High structural integrity

Microstructurally, forgings are optimal, achieving 100% density in contrast to porosity-prone castings and powder metal components. Castings, which are known for their inherent voids, segregation, microcracks, and non-uniform metallurgical structure, often have inconsistent properties. The better microstructure

allows forgings to deliver superior performance as compared to castings. See figure on the left.

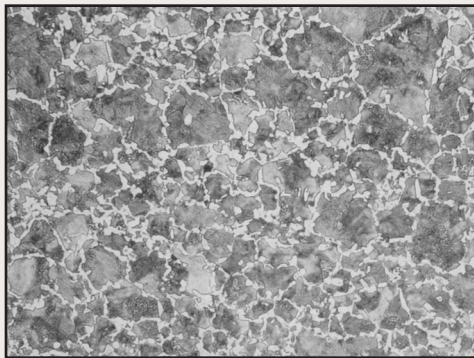

FORGED 100X

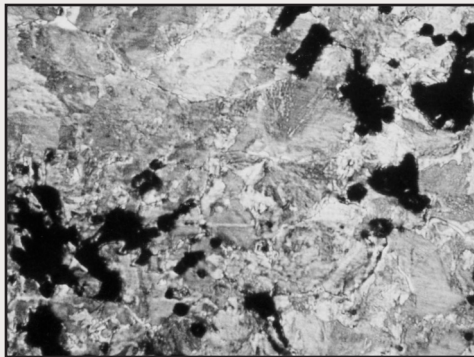

AS CAST 50X

Photomicrographs of hot forged 1045 steel (top) versus as cast 1045 steel (bottom) demonstrate the microstructural superiority of forged steel. Particularly significant is the freedom from center porosity in the forged specimen.

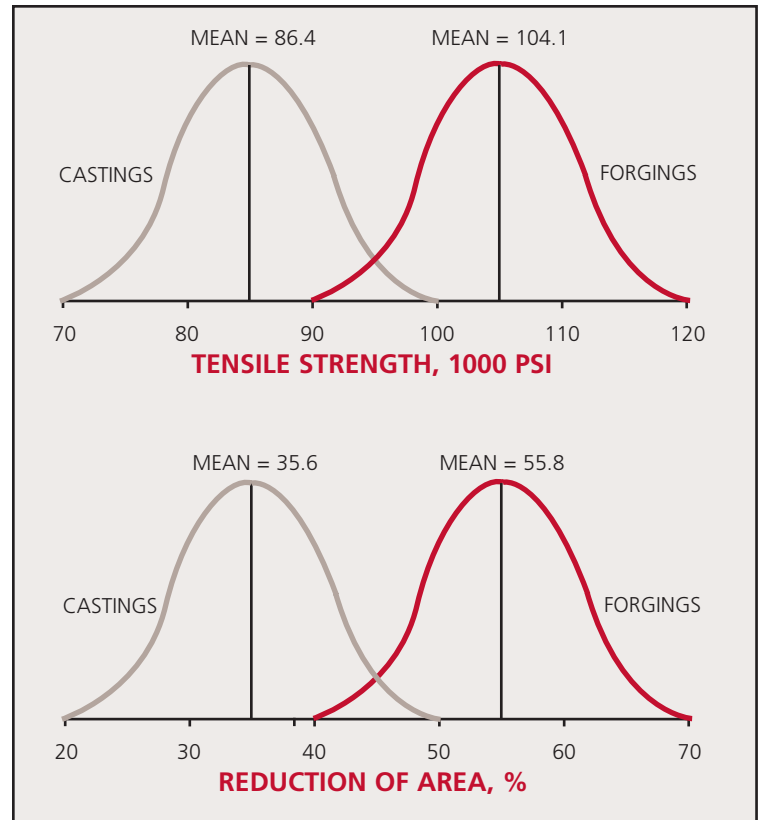

Frequency distributions for strength and ductility (indicated by reduction in area) demonstrate the superiority of forged over cast steel. When  $\pm 3\sigma$  curves are compared, they show that tensile strength and ductility values for forgings surpass those of castings over 99% of the time. Yield strength shows the same trend as tensile strength with a yield-to-tensile ratio of 0.71 for forgings compared to 0.49 from castings. Both sets of data are for normalized and tempered 0.37% to 0.38% carbon steel.

Forged large gears are preferred over castings because of their higher strength and structural integrity (absence of porosity, etc.). Both of these factors improve performance in large precision gears for high-speed applications, such as electrical generating equipment, marine power plants, and compressor drives.

Further, the clean, uniform microstructure that forged components possess allows gear makers to achieve higher, more uniform hardnesses, and to benefit from extended gear life and easier machining.

## Low product liability

Strength is the primary reason why forgings are initially chosen over other alternatives. However, some applications demand the high reliability of forgings.

Loads up to millions of pounds make rams for forging hammers one of the most severe applications imaginable. At the moment of impact, the hammer ram can experience a force up to 2,000 gs. In effect, the weight of a ham-

*Continued*

# FORGING SOLUTIONS CONTINUED

mer ram (typically ranging from 500 to 50,000 pounds) increases to 2,000 times that at impact. The resulting high stresses make forged rams the clear choice. Stronger and tougher than cast materials, forged 4140 and 4340 steel rams possess significantly higher endurance limits, making them more fatigue-resistant. Because of product liability considerations, cast rams are not even considered.

## A step above machining

Strength-wise, forgings outperform machined components, too. Even though parts machined from bar stock may not suffer from the effects of voids and inclusions, they still do not possess the integral strength of forgings, because the grain flow is interrupted at machined surfaces. In many instances, unusual shapes like a propeller nut can be forged “near-net” with the added benefit of cost savings due to reduced machining. Typically, conversion from machining to near-net shape forging (with its increased strength) boosts service life dramatically. In a number of cases, precision forging not only increases part life significantly, but causes manufacturing costs to drop, as well.

## Forged quality means less testing

Reduced testing is another important benefit derived directly from the integrity of forgings. The extreme strain rates generated during forging immediately identify the presence of defective raw material so that forgings are virtually “self-testing.” Because of the part-to-part uniformity of forgings, manufacturers do not have to ascertain the quality of every incoming component before putting parts through further in-house processing. This benefit is especially important with outside purchased components that are subsequently machined. While forgings readily lend themselves to quality control sampling plans, many castings need to be 100% tested to ensure their integrity.

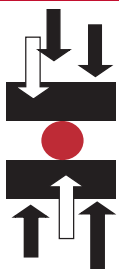

## FORGING INDUSTRY ASSOCIATION

25 West Prospect Ave., Suite 300, Cleveland, OH 44115

Phone: 216-781-6260 Fax: 216-781-0102

E-mail: [info@forging.org](mailto:info@forging.org) Website: [www.forging.org](http://www.forging.org)

# FORGING SOLUTIONS

Addressing these processes:

Impression Die	✓
Open Die	✓
Rolled Ring	✓
Cold	✓

Design Engineering Information From FIA

## TEN WAYS THAT FORGINGS HELP TO REDUCE COSTS

When properly designed, forgings can be more cost-effective than metal parts produced by alternative methods, such as castings, machined bar and plate, weldments, stampings, built-up structures, sheet metal, and other fabricated assemblies.

Even when forged parts initially cost more than competitive metal products, a look at life-cycle costs often justifies the use of forgings.

### 1. Greater strength-to-weight versus castings

Higher strength-to-weight ratios often make forgings competitive with castings; not only because of their lighter weight, but also because forgings outperform castings. Forged connecting rods for automobiles are more than 10% lighter on average, and they are also stronger than cast versions.

### 2. Eliminating weldments

Switching to forgings from multipart weldments also leads to cost reduction by eliminating labor-intensive welding and set-up operations. This approach has been successfully utilized in aircraft engines, where massive integral forgings eliminate electron-beam and inertial welds between adjacent components, and in primary missile structures, where a one-piece cylindrical forging with built-in stiffening ribs outperforms a structural shell made by welding sheet and plate to fabricate internal stiffening rings. See figure on the right.

### 3. Reduced inspection and testing

In pressure vessel applications, such as steam headers for utility boilers and catalytic crackers for petrochemical production, forgings do not require periodic inspections like welded parts do. This benefit is particularly important when welds are encased in concrete or otherwise difficult, if not impossible, to inspect.

When welds are unavoidable, flanges and other features can be incorporated in forged components to allow easily accessible butt welds to be made. In addition, increased section thickness in the boss area will help compensate for any weakness in the heat-affected zone, when welding is necessary.

Reduced quality control testing can also contribute to cost savings because forgings readily lend themselves to

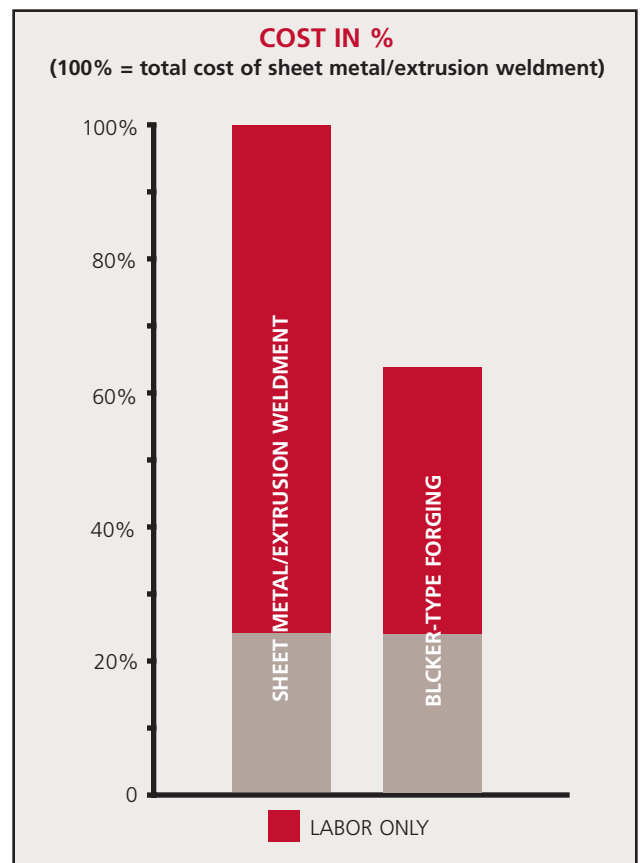

Cost analysis for a nose cowl frame shows that blocker type forgings are 36% cheaper than a sheet metal/extrusion weldment at 1200 parts. The major contributor to the higher cost of the fabrication is assembly labor.

Continued



# FORGING SOLUTIONS CONTINUED

quality control sampling plans, while 100% of critical castings need to be tested.

## 4. Replacing assemblies, fabrications

Cost savings are usually achieved when forgings replace complex fabrications and assemblies. For example, replacing a complex construction from a number of components with a single forging can cut overall manufacturing costs dramatically.

Cold forging, too, can be more economical than multicomponent assembly. Cold forging can consolidate the functionality that might have required multiple pieces plus joining into a single piece.

## 5. Less machining means lower cost

There is no doubt that forging is more economical than “hogouts” (fabricating metal components via extensive machining of plate, bar, billet, and block). See figure on the right. However, the magnitude of such savings is often surprisingly great. Particularly in aluminum aircraft applications, part complexity sometimes leads to a metal-removal cost of up to 75% of the total cost. Similarly, net-shape and near-net shape steel forgings for automotive engine, axle and transmission parts can minimize machining.

## 6. Quicker production, shorter delivery

In specific instances, in-place cost effectiveness of forgings can only be measured “after the fact.” Such was the case when a cast steel hub for a mining shovel cracked in service. It was soon discovered that a cast replacement would take at least four weeks to make. Fortunately, an open-die forged hub was produced in a matter of days, saving the customer hundreds of thousands of dollars in lost production.

## 7. Keeping competitive by fine-tuning the process

Specific process refinements are also contributing to cost competitiveness by way of material conservation. The trend worldwide in the transportation industry is to use forgings from hot to warm to cold forging (with increasing precision) in as many critical applications as possible. Drive pinions are warm forged and trunnions are cold formed, while forged connecting rods edge closer to near-net shape. See figure on next page.

Regardless of the level of precision achieved in the finished forging, careful control of billet weight and shape can eliminate flash and result in material savings of up to 40 percent in forged-steel automotive parts.

## 8. “Value-added” saves on secondary operations

Another trend is the “value-added” concept of having secondary operations like initial machining and some sub-assembly done at the forging plant, thereby reducing the cost of subsequent processing at the customer's facility.

Even when the customer does the machining, the forger can alleviate the burden of further processing. For instance, the coining process, which is used after parts are forged, produces better locating surfaces and facilitates machining. Benchmarks and positioning points can ease automation of handling and assembly. “Value-added” services at one forging plant that produces large steel blocks for plastics injection and compression molds include rough

*Continued*

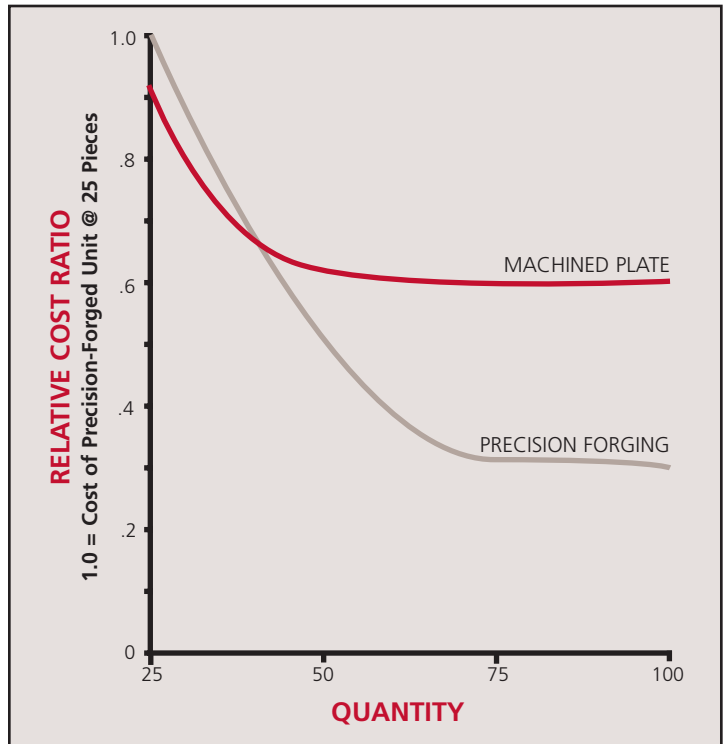

Cost comparison of precision titanium forging versus machined plate for an aircraft engine mount.

# FORGING SOLUTIONS CONTINUED

machining to within 0.5 in. of final dimensions. Consequently, customers realize both significantly lower machining costs and faster overall production times.

## **9. Materials innovations**

Less expensive, easier-to-process materials options like microalloyed steels deliver great economies in forged components such as automotive transmission and engine parts. Conserving energy by eliminating heat treatment, switching from quenched and tempered alloy steels to air-cooled microalloyed grades, saves as much as 15% on connecting rods, crankshafts, gears, steering arms, and wheel hubs. Also, forgings made from continuous cast steel on automatic presses can be cost-competitive with ductile-iron parts.

## **10. Design optimization**

There are many conventional ways to cut costs-reducing drafts, tolerances, reviewing process options, substituting lower-cost materials, making property trade-offs, and more-that should be considered to achieve the most cost-effective forging. However, optimization of a forging design should be all-inclusive for best economy.

When outside constraints limit the forging design, choosing another alloy or altering the heat-treatment practice can readily meet the increased strength requirements. However, with castings, the only recourse would be a change in design or configuration.



Warm forged automotive drive pinion (left) is produced closer to net shape than a hot forged version (right), saving material and energy and reducing required machining.

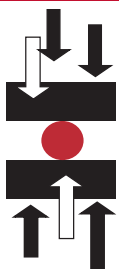

## **FORGING INDUSTRY ASSOCIATION**

25 West Prospect Ave., Suite 300, Cleveland, OH 44115

Phone: 216-781-6260 Fax: 216-781-0102

E-mail: [info@forging.org](mailto:info@forging.org) Website: [www.forging.org](http://www.forging.org)

# FORGING SOLUTIONS

Addressing these processes:

Impression Die	✓
Open Die	✓
Rolled Ring	✓
Cold	✓

Design Engineering Information From FIA

## IMPROVED ALLOYS BOOST QUALITY AND ECONOMY OF FORGED COMPONENTS

Materials developments and refinements on existing alloys can deliver higher quality, improved part performance, and significant economies for forged parts versus alternative metal components. At the top of the improved materials list are microalloyed steels, strand-cast steels, and titanium alloys.

### Microalloyed Steels

Microalloyed steels—intermediate carbon steel alloys (0.3 to 0.6% C) that incorporate small amounts of vanadium, niobium, or other elements—for forging applications offer potential economies, because mechanical properties are achieved “as-forged” via controlled cooling. See figure on right.

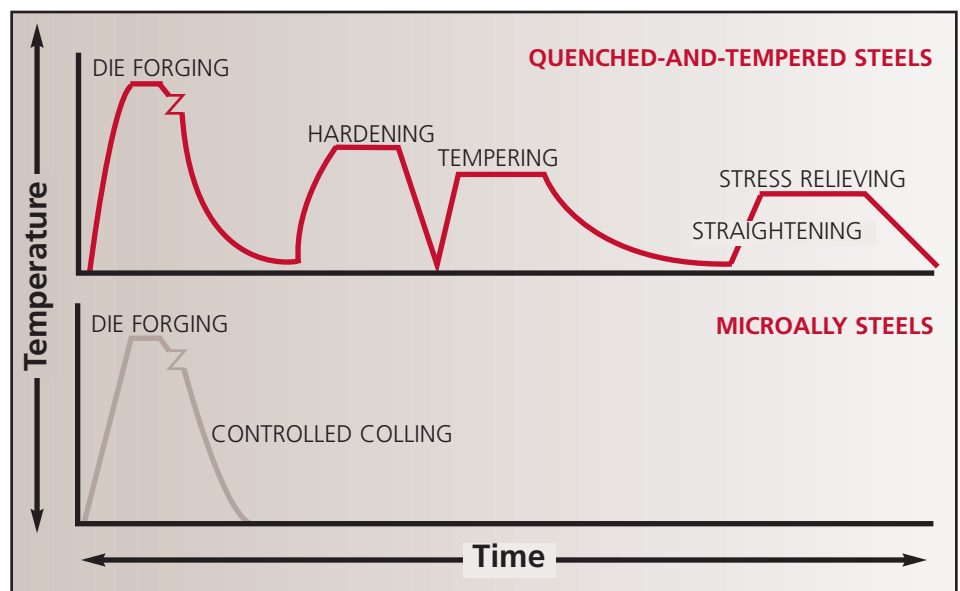

Microalloyed steel properties are developed in the “as-forged” condition. In contrast to conventional quenched and tempered steels, savings can be gained by elimination of hardening, tempering, and stress-relieving heat treatments.

A myriad of high-strength, forged components have been documented for their overall cost savings. These components include crankshafts, connecting rods, motorcycle flywheels, truck-wheel spindles, steering knuckles, lifting hooks and related hardware, and railroad coupling cylinders.

Although microalloy forgings have been utilized in Europe, Japan, and elsewhere since the early 1970s, their widespread usage in the U.S. was deferred in part because of concerns for adequate toughness and product liability. Things changed with the introduction of “second-generation” lower-carbon-content (0.1 to 0.3% C) microalloys with improved toughness and “third-generation” (0.15% C) microalloys with toughness up to six times that of earlier versions.

In fact, the third-generation microalloys with self-tempered martensite microstructures exhibit toughness and impact properties that equal or exceed those of higher alloys like quenched-and-tempered 4140, while delivering tensile strengths up to 190 ksi. See next figure. These higher-performance microalloys are targeted for automotive, agricultural, truck, and heavy equipment applications, some of which are nearing full production.

Equally significant are microalloyed steels with ferrite-bainite microstructure and low carbon content. They are suit-

*Continued*

# FORGING SOLUTIONS CONTINUED

able for a wide range of forging processes, from cold heading through conventional hot forging.

With the first-generation microalloyed steels, the Mn-Mo-Nb composition achieved a grain size of 5 microns under controlled rolling conditions. The toughness of these steels is definitely impressive: for a water quenched 138-ksi tensile strength steel, Charpy V-notch toughness exceeds 50 ft-lb at room temperature. See bottom figure. In addition, these new alloys responded well to surface hardening treatments, where extra fatigue- or wear-resistant properties are desired.

## Faster and better strand-cast materials

Steel suppliers have increased the production of strand-cast steel bar—practically all carbon and low-alloy steel grades—for forged components. Streamlined processing is moving from cast billet or bloom to forging stock to save both energy (virtually no reheating) and processing time (one rolling process versus two), resulting in cost reductions on the forging stock.

Just as important is the improved quality that is routinely achieved in strand-cast products for forging. Strand cast materials possess good internal structures, due to the incorporation of shrouding and electromagnetic stirring.

Shrouding the teeming stream prevents oxides from forming and produces a much cleaner steel that boosts fatigue performance. It also increases transverse toughness, and facilitates machinability of forged parts. Other benefits include forgings with improved surface finishes and highly uniform chemical compositions throughout.

## Materials for aerospace/high temperatures

STEEL/CONDITION	MECHANICAL PROPERTIES *				
	YS (KSI)	TS (KSI)	RA (%)	CVN (FT-LB)	
				0°F	75°F
1045/Q&T <sup>1</sup>	82	123	40	12	20
10V45/HR <sup>2</sup>	86	125	29	4	12
MAWQ <sup>3</sup> (FERRITE-BAINITE)	114	138	63	33	53
MA/AC <sup>4</sup> (FERRITE-BAINITE)	62	97	61	46	68

\* BAR FORGING TRIALS (1-IN. THICK DISKS)

1. QUENCHED AND TEMPERED. 2. HOT-ROLLED. 3. MICROALLY. 4. MICROALLY, AIR-COOLED.

**Microalloyed steels with a ferrite bainite microstructure exhibit good properties as compared to quenched and tempered steels.**

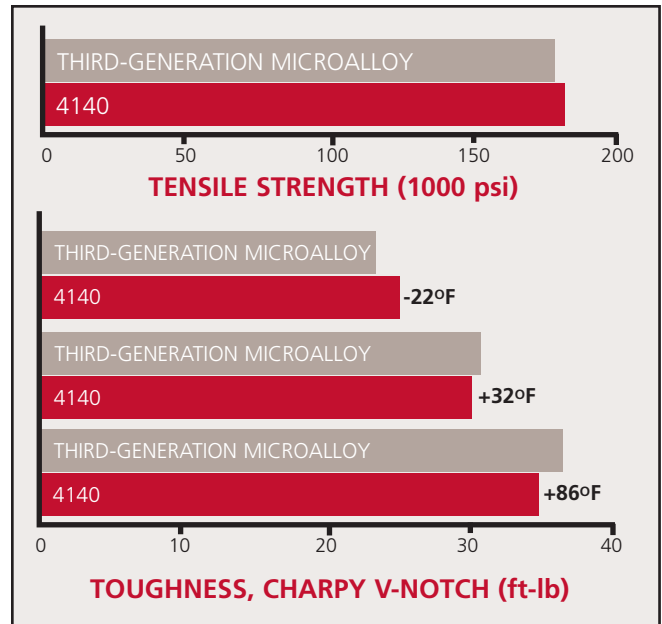

The third generation microalloyed steels possess properties equivalent to quenched and tempered carbon and alloy steels in the 35-45 HRC range.

Improved materials expanded the scope for precision forging of aerospace structural components. Although developments in hot-die technology, isothermal forging, and conventional forging techniques increased the capability to manufacture titanium net-shape forgings, alloy developments have also played a significant role.

For example, alloy Ti 10-2-3, a near-beta alloy, permits forging at lower temperatures and increases forgeability over alpha-beta alloys like Ti 6-4. Ti precision forgings can be produced with extended plan view areas (PVAs).

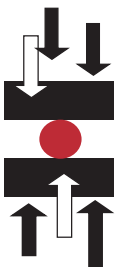

## FORGING INDUSTRY ASSOCIATION

25 West Prospect Ave., Suite 300, Cleveland, OH 44115

Phone: 216-781-6260 Fax: 216-781-0102

E-mail: [info@forging.org](mailto:info@forging.org) Website: [www.forging.org](http://www.forging.org)

# FORGING SOLUTIONS

Addressing these processes:

Impression Die	✓
Open Die	✓
Rolled Ring	✓
Cold	✓

Design Engineering Information From FIA

## VALUE-ADDED FORGINGS OFFER DESIGN OPTIONS FOR READY-TO-INSTALL PARTS

Original equipment manufacturers (OEMs) continue to demand more value-added services from their suppliers. They realize that their business should focus on design and assembly, of automobiles, trucks, planes, heavy equipment, or whatever their end product may be.

OEMs no longer want to support expensive, captive-component manufacturing operations such as forging, machining, finishing, grinding, and plating. Ideally, they want finished components delivered on a just-in-time (JIT) basis in special containers, pre-tested and ready to assemble.

Many custom forgers have been adding value to their products via heat treating and machining operations. See figures on this page. Forging companies have further augmented their capabilities with finish-machining, painting, plating, testing, and other capital equipment to facilitate the design and manufacture of ready-to-install or assemble products.

### Value-added forgings aid designers

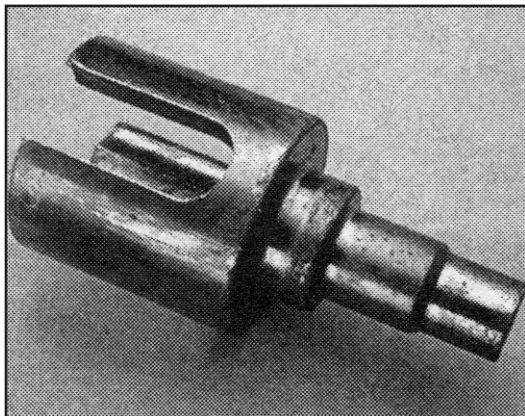

The forged "tulip" is a critical part for a constant velocity joint. It needs to accommodate the ups and downs of the suspension, the turns of the steering gear and deliver power to the wheels. The steel part was warm extruded to the finished form except for min or machining and location of specific induction hardening locations.

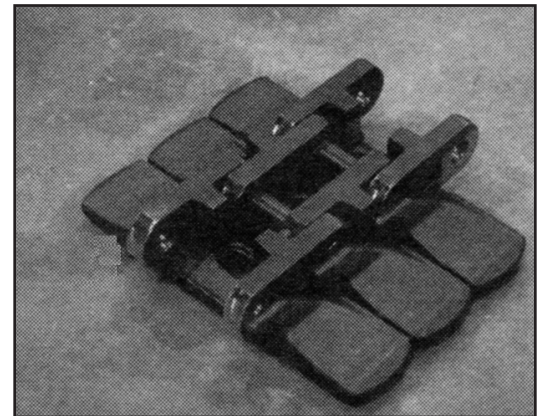

The crawler track assembly for mining machine outperformed earlier assemblies of cast low alloy steel track shoes that broke in service. The forger redesigned the shoe as a hot forged part that was 4 lb. lighter, assembled it with other forged and machined parts and delivered to the complete assembly to the customer.

While many value-added services translate directly into production-related economic benefits for the forging consumer, there are also inherent benefits for the designer. Based on design criteria—stresses the part will undergo, environmental conditions, service life, and more—designers can rely on the forger's expertise in identifying the most efficient and economical forging, heat-treating and finishing operations to produce the optimum part. A case in point is a forged slack adjuster that achieves greater levels of reliability and cuts production costs, thanks to a forger's redesign.

When a forger produces a finished, value-added forging, the limitations of in-house capabilities, the need to identify and perform interim processing steps, and the evaluation of potential secondary suppliers are no longer primary concerns. In effect, a single forging supplier requires less technical coordination than multiple suppliers or in-house operations. The range of services available expands the number of options open to the designer.

Perhaps even more important, the forger can make the designer's job easier by recommending processing changes and ancillary operations that

*Continued*

## Key cost saving benefits of value-added forgings

- ✓ Smaller, lighter, higher-performance parts.
- ✓ Improved designs for mating components.
- ✓ More accurate, tighter-tolerance parts.
- ✓ Higher-quality parts, resulting in fewer rejects.
- ✓ Reduction of in-house scrap.
- ✓ Minimized assembly operations.
- ✓ Additional capacity for in-house manufacturing.
- ✓ Streamlined procurement.
- ✓ Reduced technical coordination.
- ✓ Simplified quality assurance testing and source inspection.
- ✓ Better process control and fewer production problems.
- ✓ Reduced shipping, trafficking, and scheduling.
- ✓ Minimal technical staff support.
- ✓ Simplified receiving/stocking operations.
- ✓ Just-in-time (JIT) deliveries.
- ✓ Reduced inventory.
- ✓ Quick turnaround on similar designs.

in the forger's experience yield a nearer-to-net-shape part. Often, the forger can help come up with subtle design changes, features, or processing refinements that permit a smaller, lighter, or higher-performance forged component to do what otherwise might not have been possible.

## Significant cost savings

Why opt for value-added forgings? Simply put, studies point out that significant cost and time savings can be realized for just about any type of forged component. For the forged part consumer, fewer secondary operations mean fewer headaches, reduced in-process controls and inspection, less manpower, and a smaller capital investment in equipment. (See Table 1 for additional benefits.)

## Wide range of value-added services

Adding value to a forged product by performing ancillary operations normally done by the OEM can range from supplying pre-qualified parts (ready to go through further processing, such as machining ) to fully finished assemblies that incorporate forgings as the major component. In general, value-added services include just about any operation or process performed after forging, but are not limited to post-forging capabilities.

Some major value-added services may include:

- ✓ Custom processing results in more dimensionally accurate or closer-to-net shape parts, and it also helps reduce secondary operations. For instance, coining processes produce closer tolerances or better locating surfaces, which reduce a customer's machining operations. Combinations of hot and cold forging or warm forging produce components closer to net shape, eliminating expensive machining operations.
- ✓ Testing includes destructive and nondestructive (NDT) testing, as well as statistical data analysis for SPC (statistical process control), coordinate measuring machines, and others.
- ✓ Computerized design/analysis can be used to help design parts to the optimum configuration. CAD/CAM (computer-aided design/manufacturing), flow modeling, AI (artificial intelligence) systems, etc. can expedite accurate designs and shorten production schedules.
- ✓ Electronic data transfer includes transfer of engineering drawings, CAD data, and CAM data for machining at customers' plants and to conduct entire purchasing transactions-purchase orders, shipping and certification data, delivery dates, quotations, and more.
- ✓ Heat treating ranges from typical annealing and normalizing to full hardening and tempering, but also includes nitriding, vacuum heat treatments, and special treatments such as strain-aging, precipitation hardening, and double tempering, where deemed necessary for high performance alloys.
- ✓ Target dimensioning puts "targets" (benchmarks or reference points) on a part so that the customer can do subsequent machining without having to re-qualify the part. Coordinate measuring machines and six fixture points are sometimes used, especially for aerospace structural forgings, where up to 75% of the component weight is typically removed.
- ✓ Machining operations range from rough to finish operations with a specified surface roughness. Drilling holes, cutting threads, surface grinding, center drilling, CNC (computer numerical control) machining, and just about any other metal-removal operation are within the realm of these services.

*Continued*

# FORGING SOLUTIONS CONTINUED

- ✓ Finishing operations run the gamut of plating, anodizing, and protective-coating operations, including durable epoxy finishes for subassemblies.
- ✓ Subassembly work can be performed especially when automated assembly/manufacturing operations can occur due to long-term contracts.
- ✓ Special requirements, often requested by the customer, are becoming more prevalent. A prime example is the use of special containers, supplied by the customer and designed to facilitate assembly or further processing at the customer's plant. Another forger pre-balances forged wheels to save the customer this burden after delivery.

## Teamwork essential

Not surprisingly, taking full advantage of value-added forgings requires open communications. Your forging supplier must have a firm understanding of design criteria, and accurate final part drawings should be submitted as early as possible. All component details should be specified, including mating-surface conditions, subassembly work, and potential options on design features.

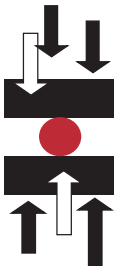

## FORGING INDUSTRY ASSOCIATION

25 West Prospect Ave., Suite 300, Cleveland, OH 44115

Phone: 216-781-6260 Fax: 216-781-0102

E-mail: [info@forging.org](mailto:info@forging.org) Website: [www.forging.org](http://www.forging.org)

# FORGING SOLUTIONS

Addressing these processes:

Impression Die	✓
Open Die	✓
Rolled Ring	✓
Cold	✓

Design Engineering Information From FIA

## FORGING SIZE PLUS SHAPE CAPABILITY EXPANDS METAL DESIGN OPTIONS

It is no design secret that forgings are often considered for their high strength, structural integrity, extra long service life, unmatched impact toughness, and other desirable characteristics. But what is not usually thought of is the tremendous design versatility, achievable by the wide range of components that can be forged with current technology.

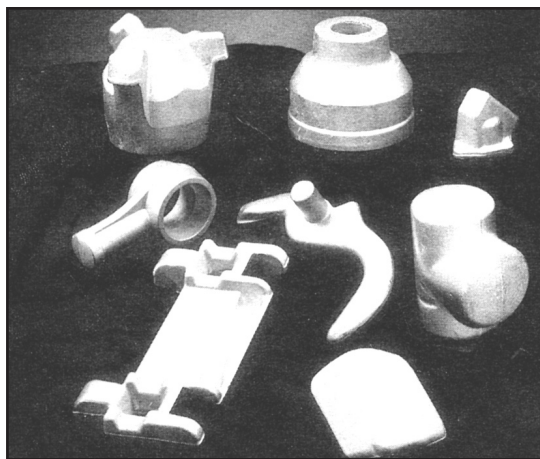

Figure 1. Impression die forging has great shape capability.

Evolutionary developments—among them, key processing refinements, computerized equipment, and newly developed alloys—permit larger-size components, more complex configurations, and closer tolerances to be achieved in most forging processes. Part size has expanded while shapes approach an ever-increasing degree of part complexity.

With few limitations, virtually any shape imaginable can be forged, or can be economically put together with forged components. Shapes range from bars with basic cross sections (round, square, hexagonal) and simple shafts to complex, contoured profiles that integrate a thin rib-and web structure and built-in attachment features. Similarly, size capability for all forging processes covers an enormous range, from ounces to more than 150 tons. However, each of the many forging processes has its own special design niche in terms of size, shape, part complexity, and material options.

Impression-die (closed-die) forging of steel can produce an almost limitless variety of three-dimensional shapes that range in weight from mere ounces up to more than 25 tons. See Figures 1 to 3. Additional flexibility in forming both symmetrical and nonsymmetrical shapes comes from preforming and blocking operations (sometimes bending) prior to forging in finisher dies.

Part geometries range from some of the easiest for forge, such as simple spherical shapes, block-like rectangular solids, and disc-like configurations, to the most intricate components with thin and long sections that incorporate thin webs, as well as relatively high vertical projections like ribs and bosses. Accompanying photos dramatically demonstrate forged-shape capability.

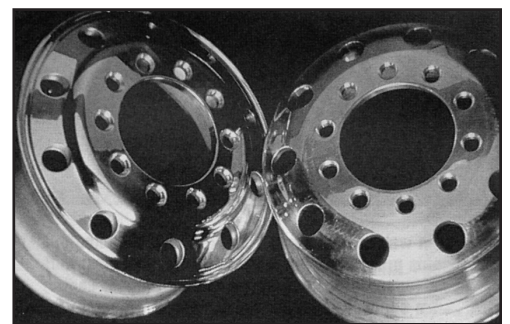

Figure 2. Impression die forged aluminum wheels.

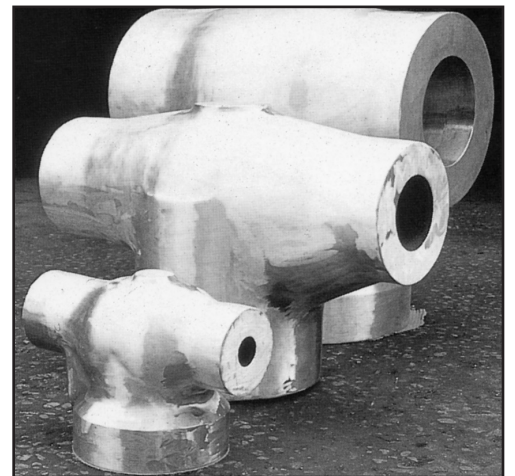

Figure 3. Steel valve bodies, press forged in closed dies.

*Continued*



# FORGING SOLUTIONS CONTINUED

Most engineering metals and alloy can be forged via conventional impression-die processes, including carbon and alloy steels, tool steels and stainless steels, aluminum and copper alloys, and certain titanium alloys. Strain-rate- and temperature-sensitive materials (magnesium, highly alloyed nickel-based superalloys, refractory alloys and some titanium alloys) may require more sophisticated forging processes or special equipment for forging in impression dies.

Applications span the industrial spectrum ranging from structural parts for automobiles, trucks, aircraft/aerospace, and heavy-duty manufacturing equipment to hardware, fixtures, and hand tools.

Open-die forging can produce forgings from a few pounds up to more than 150 tons. In addition to basic shapes, open-die processes yield stepped cylinders, large step slabs (upset or “pancake”), hollows, hubs, rings and contour-formed metal shells. See Figures 4 and 5. Practically all forgeable ferrous and non-ferrous alloys can be open-die forged, including exotic materials like age-hardening superalloys and corrosion-resistant refractory alloys.

Hollows, formed by open-die forging techniques (either forging over a mandrel or forging between an enlarging bar and the top die of a press) offer unique part geometries. See Figure 6 and 7. Basically cylindrical hollows, these carbon steel and alloy steel forgings can weigh just a few hundred to as much as several hundred thousand pounds.

With certain restrictions on other dimensions, forged hollows can attain 200 in. diameters or 300 in. lengths; smallest diameters are just under 12 in. In general, as diameter decreases, length can increase. Similarly, wall thickness depends on other dimensional constraints. For large diameters, a 2 to 3 in. minimum thickness is required. Hollows have been forged as thick as 24 in.

Hollows can be forged with steps on the outside, as well as steps and tapers on the inside, presenting in many smaller-diameter components a higher-performance alternative to tubing. Even large hollows can be contoured, forged with different diameters along the length, and incorporate forged-in ports or extruded nozzles by use of special forging techniques.

Forged rings, made by ring rolling or hammer forged over a saddle/mandrel set-up, can weigh from 1 lb. up to 350,000 lb., while outer diameters range from just a few inches up to 30 ft. in diameter. See Figure 8.

Seamless ring configurations can be flat (like a washer), or feature higher vertical walls (approximating hollow cylindrical sections). Heights of rolled rings range from less than an inch up to more than 9 ft. Depending on the equipment, wall thickness/height ratios can typically range from 1:6 up to 16:1, although greater proportions have

*Continued*



Figure 4. Open die forged shafts of hardened steel.

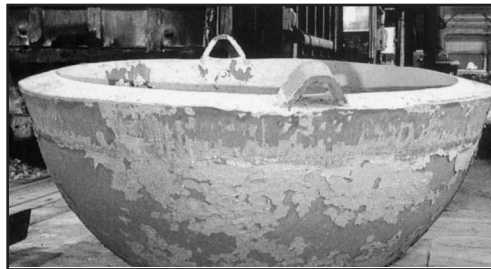

Figure 5. Contour formed pressure vessel component.

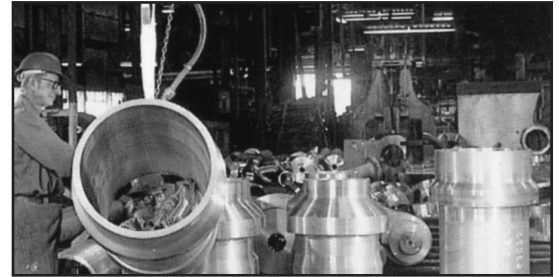

Figure 6. Hollows forged by open die forging.

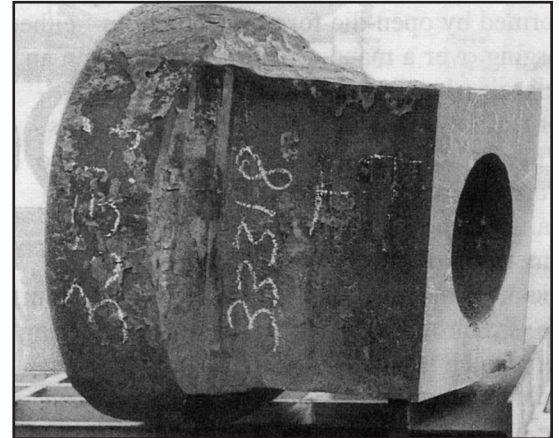

Figure 7. Open die forged hub for a mining shovel.

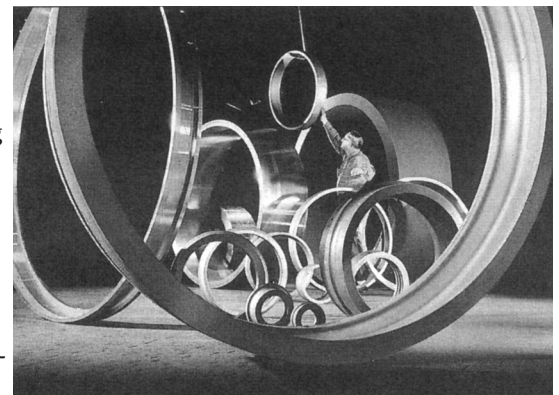

Figure 8. Shapes and sizes for seamless rolled rings.

# FORGING SOLUTIONS CONTINUED

been achieved with special processing. In fact, seamless tubes up to 48 in. in diameter and over 20 ft. long are extruded on 20- to 30,000-ton forging presses.

Beyond the basic shapes with rectangular cross-sections are rings with complex cross-sections. These contoured rolled rings can be produced in thousands of different shapes with contours on the inside and/or outside diameters.

High tangential strength and ductility make forged rings well-suited for torque- and pressure-resistant components, such as gears, wheel bearings, and couplings, rotor spacers, sealed discs and cases, flanges, pressure vessels, and valve bodies. Materials include not only carbon and alloy steels, but also nonferrous alloys of aluminum, copper, and titanium, as well as nickel-based alloys.

Upset forgings are ideal for cylindrical parts that incorporate a larger diameter or “upset” at one or more locations along the longitudinal axis. See Figures 9 and 10. Usually forged from bar, upsets typically weigh from 1 lb. up to about 400 lb. for 20 ft.-long components, although lengths up to 30 ft. have been forged. Depending on upsetter size, upset diameters range from just under 3 in. up to 17 in.

Once limited to simple parts “headed” on one or both ends, upset forgings include components with larger diameter sections upset in the center, more complex shapes via multiple dies, internal and offset upsets, and even double-ended upset hollow formed from tubular stock.

Targeted for such applications as gears, stub shafts, axles, roller shafts, steel bodies, as well as for blanks for further processing in other forging equipment (e.g., pinion-gear blanks), upsets are typically made of carbon or alloy steel, although any forgeable alloy can be used.

Precision forging produces component designs with most functional surfaces forged to net dimensions with virtually no contour machining required. See Figures 11 to 13. Typical structural part shapes in aluminum include: channel or “C” sections with flat backs; spar-type parts (long narrow parts with an “H” section or a combination of an “H” and channel with cross ribs) than can be 6 to 8 in. wide by 60 to 80 in. long; and large parts in a variety of shapes.

Along with design complexity, the size of precision aluminum forgings has also increased. High-definition parts (web thicknesses in the 0.070 to 0.080 in. range, ribs at about 0.100 in. thick, and contours on both sides) have been produced with plan-view areas (PVA) up to 600 in<sup>2</sup>.

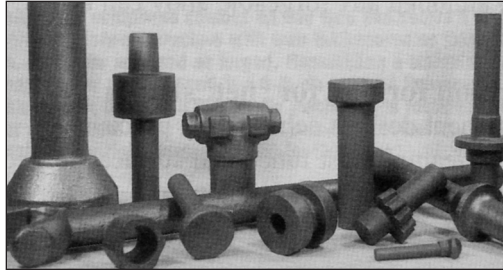

Figure 9. Upset shaft like parts ranging in weight from 2 to 110 lbs.

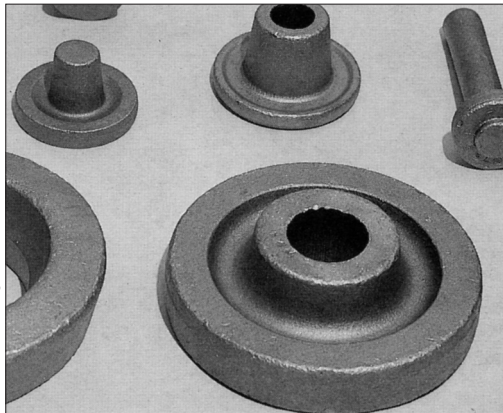

Figure 10. Additional shape capabilities of upset forging.



Figure 11. Precision forged steel gears.



Figure 12. Precision forged aluminum parts with ribs less than 0.1 in. thick.

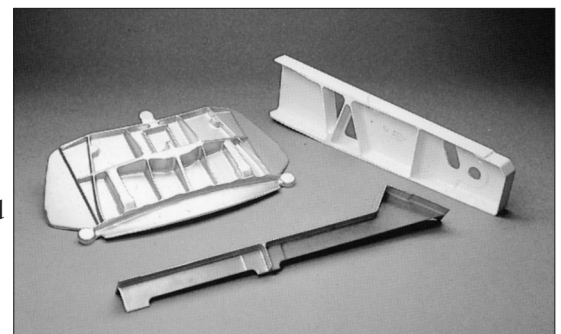

Figure 13. Precision forge titanium components.

*Continued*

# FORGING SOLUTIONS CONTINUED

The achievable PVA of a part depends on how restrictive the rib/web structure is, as well as on rib thicknesses, rib heights, etc. Larger, heavier parts (thicker ribs and webs) with 800 in<sup>2</sup> PVAs have been produced. Similarly, precision forged titanium components can be fairly large with some complexity.

Precision forging is not limited to only aircraft structurals of aluminum and titanium. Precision warm forging of steel has been successful in producing gears, geared shaft assemblies and similar shapes.

Cold forging encompasses many processes—bending, cold drawing, cold heading, coining, extrusion, punching, thread rolling and more—to yield a diverse range of part shapes. See Figure 14. These include various shaft-like components, cup-shaped geometries, hollow parts with stems and shafts, all kinds of upset (headed) and bent configurations, as well as combinations.

Parts with radial flow configurations with center flanges, rectangular parts, and non-axisymmetric parts with 3- and 6-fold symmetry have been produced by warm extrusion. With cold forging of steel rod, wire, or bar, shaft-like parts with 3-plane bends and “headed” design features are not uncommon.

Typical parts are most cost-effective in the range of 10 lb. or less, and symmetrical parts up to 7 lb. readily lend themselves to automated processing. Materials options range from lower-alloy and carbon steels to 300 and 400 series stainless steels, selected aluminum alloys, brass and bronze.

Often chosen for integral design features such as built-in bosses and flanges, cold forgings are frequently used in automotive steering and suspension parts; namely, in antilock-braking systems, hardware, defense components, and other applications where high strength, close tolerances, and volume production make them an economical choice.

Hot-die and isothermal forging make it possible to forge exotic vacuum-melted, titanium, and nickel-based alloys, such as Waspaloy, Astroloy, and P/M alloy IN100, which are far more difficult to forge by conventional techniques. See Figures 15 and 16. In this process, dies are heated close to the workpiece temperature, and in the case of isothermal forging to about 2000°F. A controlled atmosphere or vacuum is required.

Most are disk-type shapes with diameters from about 6 to 36 in., weighing from about 70 to 1,000 lb. In general, thicknesses can range from approximately 1/2 in. up to 9 in., while a cross-section in a typical part may have thicknesses that vary from a maximum of 3 to 7 in. down to 1/2 in. in a thinner web section. Part shapes are not as complex as those that can be achieved by precision forging of aluminum, but isothermal forging of titanium alloys can yield rib/web components with rib thicknesses from 1/8 to 1/4 in. Most applications are critical components for gas turbine engines and similar high temperature environments.



Figure 14. Precision forge titanium components.

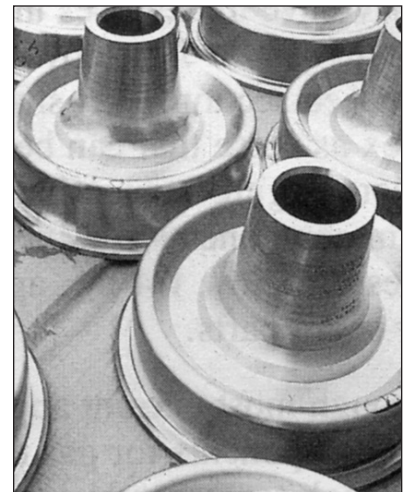

Figure 15. Gas turbine components hot die forged from titanium.

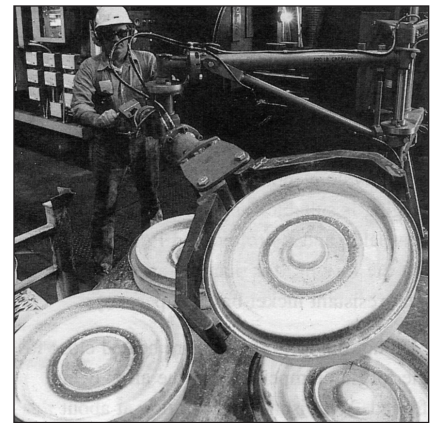
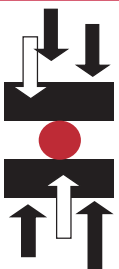

Figure 16. Isothermal forging of difficult to form alloys to near net shapes.



## FORGING INDUSTRY ASSOCIATION

25 West Prospect Ave., Suite 300, Cleveland, OH 44115

Phone: 216-781-6260 Fax: 216-781-0102

E-mail: [info@forging.org](mailto:info@forging.org) Website: [www.forging.org](http://www.forging.org)

# FORGING SOLUTIONS

Addressing these processes:

Impression Die	✓
Open Die	✓
Rolled Ring	✓
Cold	✓

Design Engineering Information From FIA

## THE BEST ANSWER TO THE COST/PERFORMANCE QUESTION

Conversion to forgings is an idea that does not often occur unless previous parts have failed in either service or prototype testing. However, considering success of forgings versus not-so-successful alternative components, designers are discovering many more reasons to convert to forgings. Even though the main thrust is usually higher performance and/or lower cost, equally important considerations (and some not so obvious) justify the switch to forgings. (See table).

It is no secret to forgers that competitive products are often not up to par with forgings, performance-wise. In fact, customers' requests to replace castings, machinings, weldments, composite assemblies, stampings, and the fabricated parts in virtually all markets are becoming more frequent. This is happening not only in aircraft and aerospace, but also in automobiles, transportation, mining and construction, chemical processing, tooling, and all kinds of heavy-duty and manufacturing equipment.

Not surprisingly, these changes are closely related to life-cycle cost analysis. In terms of service life, a higher-performance forging can cost a mere fraction of metal components made by alternative processes. Back when forging was connoted as a "blacksmith" trade, the advantages of forged hand tools over cast and other versions were quickly realized. The same quality advantage still holds true. 120 million sockets and millions more forged open-end wrenches, ratchets, and handles are sold every year. No one questions their reliability or performance.

One step up are pneumatic power tools like jack hammers, which have critical components made of forged, cast, or machined components. What is the difference? The quality advantage of pneumatic tools with forged fronthead and backhead cylinders permits longer warranties as compared to tools with non-forged critical parts. Higher performance via forgings commands only a 10% to 15% premium upon purchase, while delivering a ten-year life compared to one to two years for other methods. See top figure on next page.

### Aircraft, aerospace applications

Structural components in aerospace/aircraft applications have routinely switched to forgings, especially for complex design geometries that cannot be effectively made by any other process. Both conventional

### WHY CONVERT TO FORGING?

- ✓ Field failures of non-forged parts
- ✓ Improved overall quality
- ✓ Greater structural integrity
- ✓ Higher strength and/or toughness
- ✓ Longer service life
- ✓ Lighter weight
- ✓ Cost savings
- ✓ Materials savings
- ✓ Easier to manufacture
- ✓ Reduced warranty costs
- ✓ Expanded material choices
- ✓ Reduced machining and secondary operations
- ✓ Tighter dimensional tolerances
- ✓ Integrity to resist high pressures
- ✓ Higher wear resistance
- ✓ Greater transverse properties
- ✓ Better surface quality
- ✓ High acceptability rate (minimum rejects)
- ✓ Directional strength for more reliable, efficient designs
- ✓ Net and near-net shapes
- ✓ Ready-to-install parts
- ✓ Higher safety factor for life-critical applications
- ✓ Part consolidation
- ✓ Consistent, uniform properties
- ✓ Shorter lead/production times
- ✓ Volume-sensitive production
- ✓ Reduction of vendor base (forgers out source finishing, etc.)
- ✓ Minimum in-plant operations

*Continued*

# FORGING SOLUTIONS CONTINUED

and precision forgings have repeatedly been much more cost-effective and/or deliver higher performance than “hogouts” of plate, castings, advanced polymer-matrix composites, multi-part assemblies, and weldments. In life-critical applications, a larger safety factor is all the more reason to consider a reliable solution.

In such applications, the performance/cost balance is a primary driver. However, considering typical precision forgings with as-forged surfaces and built-in design features, machining cost can be cut by 90%. Overall, total cost can be cut in half, while properties, performance, and service life often improve. In one example of a precision-forged actuator bracket for a wide body jet, a “design stage” conversion cut cost by about 75% over machining a rectangular block, and at the same time, improved fracture toughness, stress-corrosion resistance, and eliminated almost all machining.

Other examples in the aerospace sector include “classic” conversions; namely, those where castings failed because they just were not strong enough. Such was the case with a primary structural component (bulkhead) for a loitering, radar-sensing missile. See bottom figure. Designed as a casting in the interest of lower initial cost. It was then converted in production to a forging because of performance. Similarly, another missile part was originally conceived as a casting, then as a hogout from bar stock. In the final analysis, it became a forging.

Fuel components for commercial gas turbine engines have been converted to forgings, then to investment castings, and now are back to forged stainless steel and nickel alloys. “True” cost-effectiveness is realized by the inherent quality of forgings plus the use of advanced machining centers. Similarly, a titanium compressor case for an aircraft engine went from a forging to a casting to save money. Unfortunately, casting the complex part created numerous, difficult production problems. It became a forging again.

Other examples of conversions include:

- ✓ a propeller nut converted to a near-net-shape forging with cost savings over a machining;
- ✓ a precision-forged aluminum blocker door that replaced a built-up composite structure; and
- ✓ a structural forging for a VTOL aircraft switched from an advanced-composite part because property “spread” of composites was excessive.

Moving into the “upgrade” mode, higher-performance/efficiency engines demand higher strength-to-weight-ratio forgings. Aircraft-engine forgings can provide 33% higher ultimate tensile strength versus castings, higher pressure capability, 5% to 10% lighter weight, and reduced section sizes.

## Ground transport: autos, trucks

Practically every major structural or high-load component in trucks and autos has been evaluated as a forging. Conversions to forging routinely occur when higher performance benefits or longer life are required. In both heavy trucks and luxury automobiles, higher performance has been attained by forged aluminum wheels that outperform cast versions. Crankshafts for high-performance engines have been converted to forged steel from ADI (austempered ductile iron) and cast iron. Worldwide, camshafts have been converted to steel forgings

Elsewhere in the automobile, many suspension parts are being converted to forgings. In one instance, a steering arm made as a multi-component weldment (two stampings plus one machined part) failed. Fortunately, a hot-forged, carbon steel part was not only stronger, but also lighter, closer to net shape, and less expensive. In parallel,

*Continued*

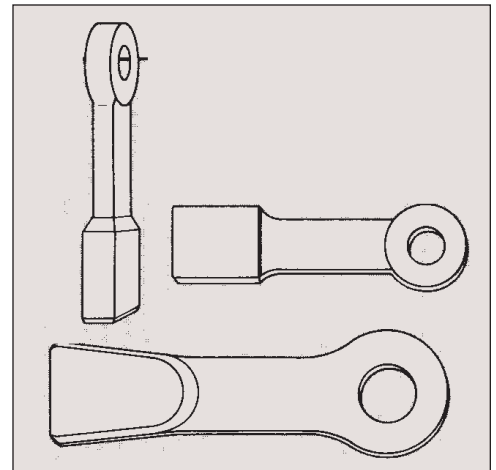

The forged 7 to 20 lb. steel hammers that pulverize coal and clay have replaced cast components. The product life has increased five times.

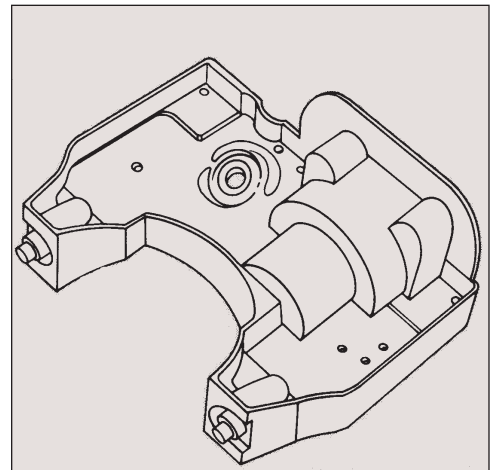

The precision forged bulkhead for a missile replaced a sand casting. Some of the webs are 0.120 in. thick.

# FORGING SOLUTIONS CONTINUED

a cold-forged-steel upper control arm replaced a stamped version.

Other examples of conversions include:

- ✓ forged-aluminum engine mounts replaced cast iron, cutting weight by more than 60%, reducing machining, and adding functions;
- ✓ steel gears for heavy trucks and construction vehicles forged with net-shape teeth to deliver up to ten times the impact fatigue life of machined counterparts;
- ✓ slack adjusted for braking systems of truck trailers switched to a steel forging when castings could not meet industry standards for life, safety, reliability; and
- ✓ brake-system components switched to forged aluminum for lighter weight.

## High pressure and hydraulics

More high-pressure parts than ever are being converted to forgings because of their inherent structural integrity, which translates into freedom from porosity, segregation, large inclusions and other as-cast defects. This makes forgings highly unlikely to leak under high pressures. Examples of conversions include:

- ✓ "flashless" precision-forged aluminum components for aircraft hydraulic systems, minimized parting-line end grain and replaced castings and machinings;
- ✓ forged-steel caps, rod ends and ports for 3000 psi hydraulic cylinders replaced leakage-prone bar stock, plate and cast steel for up to 85% cost savings;
- ✓ critical high-pressure components for submarines switch to forged high-temperature steels from castings for increased safety factors; and
- ✓ multi-port compressor cylinders that operate at 5000 psi were quickly switched to forgings from castings in the design stage due to as-cast porosity and low property levels.

## Energy, processing applications

Energy generation, ore and coal mining, and metal/chemical processing industries present some of the toughest environments for metal components. Forging conversions include:

- ✓ planetary gears for an industrial gas turbine engine first were made as castings, but manufacturing problems prompted the switch to higher-performance forgings;
- ✓ stopnut for an oil-field ball valve involved piercing, broaching, welding and drilling - a cold forging needs just one hole, and
- ✓ cast-steel shoes for mining machines that failed were redesigned as forgings.

## Simple parts

Switching to forgings can make economic sense for simple parts, as well as complex geometries. Support brackets, for instance, were converted to forgings at a 80% cost reduction.

If you are a designer, and you have not previously considered forgings for your metal-component designs, contact FIA ([www.forging.org](http://www.forging.org)) to explore what may be your best cost/performance alternative. Higher performance and/or cost-savings can be realized in aluminum, steel, titanium, and even exotic alloys.

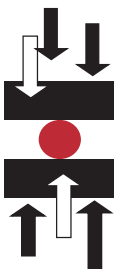

## FORGING INDUSTRY ASSOCIATION

25 West Prospect Ave., Suite 300, Cleveland, OH 44115

Phone: 216-781-6260 Fax: 216-781-0102

E-mail: [info@forging.org](mailto:info@forging.org) Website: [www.forging.org](http://www.forging.org)

# FORGING SOLUTIONS

Addressing these processes:

Impression Die	✓
Open Die	✓
Rolled Ring	✓
Cold	✓

Design Engineering Information From FIA

## CONTINUOUS IMPROVEMENT HELPS FORGINGS DELIVER OPTIMUM QUALITY

"Quality" has always been a primary concern for metal components. Engineers rank forgings above all other competitors for overall quality, structural integrity, high strength, longest service life, and unsurpassed toughness. The forging industry is not resting on its laurels, and the quest for improved quality continues.

Demands for even higher quality are being met by such techniques as total quality management (TQM), statistical problem solving, statistical process control (SPC) and design of experiments (DOE), as well as by process improvements and refinements, new materials, and technologies like CAD/CAM. The automotive, aerospace, military, and other users of forgings are requiring quality improvements from all suppliers.

In the forging industry, quality improvements are being made by practically every means imaginable, delivering such benefits as better dimensional control, tighter tolerances, improved property uniformity, optimized designs, lower scrap rates, and improved lead times.

- ✓ *Appropriate technology* like CAD/CAM is being utilized throughout the total production process to produce more dimensionally accurate forgings. In one instance, use of the CAD/CAM approach for design, die making, and finish machining operations allowed a complex rib/web structural forging to be produced to a 25% tighter-than-normal tolerance band on both die-closure and tolerance dimensions. Similarly, process modeling (metal-flow simulation, for example) is being used to produce optimum designs and, hence, more repeatable forgings.
- ✓ *Improved die-making practices* are the first step in producing more accurate forgings. CAD geometry may be utilized to produce the CNC tool path to machine electrodes for EDM (electrical discharge machining) of dies, thereby producing more accurate forgings. Where warranted, forging consumers can opt for more exotic techniques such as electrochemical polishing after EDM. This die-making approach can hold tooth-to-tooth dimensions to within 0.0005 in. on precision-forged steel gears.
- ✓ *Fast-tool-change capability* is another way to maintain dimensional repeatability in products forged in larger quantities. Typically, specialized tooling attachments permit fast tool changes to accommodate intentional, preplanned die insert replacement. This approach minimizes the effects of tool wear without decreasing productivity.
- ✓ *Target machining or center drilling* is another way that forgers help ensure overall dimensional precision by drilling, machining, or coining built-in X-Y-Z gauge points (reference points) on forged parts. This "prequalifies" forged components for subsequent machining or other operations, helping to maintain dimensional accuracy at the customer's plant.
- ✓ *Process combinations and refinements* can also be very effective in achieving closer tolerances. One example is hot forging combined with cold forging (coining) of a steel crankshaft to achieve tolerances half that of hot forging alone.

*Continued*

# FORGING SOLUTIONS CONTINUED

- ✓ Better materials, such as the use of microalloyed steels in place of standard heat-treated steels, can dramatically improve the consistency of a forged product. Not only is hardness more consistent, but also strength can be higher and more uniform.
- ✓ Induction heating is yet another process that is helping to produce more uniform forgings. In contrast to gas-fired furnaces, induction heating evenly heats bar stock, resulting in more uniform properties in forgings. It also significantly reduces surface scale.
- ✓ Coordinate measuring machines (CMMs) are utilized to confirm greater die accuracy and to measure critical part features, such as angles and complex curvatures, which could not previously be measured. Here, the ability to measure more accurately directly translates into forgings with more repeatable dimensions. When linked to a CAD database, CMMs can minimize or eliminate source inspection.

## Statistical means to a “quality” end

With improvement in mind, statistical analysis of the forging process has become a powerful tool to boost the overall quality of forgings. It has been implemented for both ferrous and nonferrous forgings, to achieve tighter tolerances, more consistent properties, lower reject rates, less rework, higher productivity, and other quality-related benefits, including increased cost effectiveness. Statistical process evaluation, process capability studies, process improvement programs, SPC (statistical process control) charting, design of experiments and other techniques have made impressive headway toward improving the forging process.

Process capability studies have proven invaluable for controlling the impression-die forging process. In one instance, tolerances for forged-steel components went from 150% of the product tolerance down to 30%. By adjusting process variables, the spread of dimensional variation was reduced by a factor of five. In another case, once a process capability index  $C_{pk}$  of 1.33 was attained, the company was able to adjust the process (and control limits) so that die life was maximized without sacrificing part quality.

The same techniques have yielded good results with aluminum impression-die forgings. For example, with an automotive structural part, a capability study of die-closure dimensions showed that the process was producing too many parts outside the specified range. Here, adjusting process variables brought the process into statistical control, reducing the rework rate from almost 50% down to 0.

Another aluminum-forging process was producing parts with dimensions on the high side of the range. By a simple process adjustment, dimensions were centered to produce a tighter spread. Because of the many process variables involved (some interdependent), some forging companies have ascertained that working toward "target" values for specific variables rather than specification ranges produces much more uniform dimensions and, consequently, more consistent forgings.

Rolled rings have improved in quality (dimensionally, property-wise and even economically) due to statistical problem solving and related techniques. At one forging company, deviations and rework decreased by 42% over two years—with savings of more than \$1 million in one year—as a result of analyzing which particular products were most difficult to manufacture. This approach helped to dramatically increase "first time" acceptable parts.

Because rolling operations are very operator-sensitive, the company supplied operators with process history and attribute data, which includes 34 different "cause codes," such as surface imperfections and eccentricity.

Another rolled-ring producer was able to adjust the process and/or directly modify equipment for long-term improvement. Typically, this approach involves investigating a particular area (like blank preparation or temperature control),

*Continued*



# FORGING SOLUTIONS CONTINUED

statistically analyzing that area, then making modifications to keep the process variable under control. In one example, the company adjusted the process to reduce ring weight, while still maintaining an optimum process control index. This resulted in cutting weight by 10 lb. per part and reducing machining operations, resulting in a calculated savings for both customer and forger.

During any program to improve the repeatability of forgings, it quickly becomes evident that forging is a very complex process with many variables, including heating, cooling, shrinkage, material-transformation effects, press speed and size, volume, die characteristics, and a host of others. Fortunately, a design of experiments approach can be invaluable in better understanding the forging process and determining which combination of variables yields the best results. A designed experiment identifies critical process variables and implies working toward "target" variable values instead of conventional ranges. The net result can be significant process improvement. This approach allowed one forging company to change key variables for a difficult-to-process alloy, resulting in a significant reduction of internal defects without sacrificing mechanical properties.

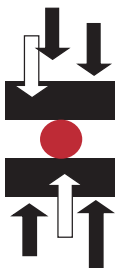

---

## FORGING INDUSTRY ASSOCIATION

25 West Prospect Ave., Suite 300, Cleveland, OH 44115

Phone: 216-781-6260 Fax: 216-781-0102

E-mail: [info@forging.org](mailto:info@forging.org) Website: [www.forging.org](http://www.forging.org)

# FORGING SOLUTIONS

Addressing these processes:

Impression Die	✓
Open Die	✓
Rolled Ring	✓
Cold	✓

Design Engineering Information From FIA

## CO-ENGINEERED FORGINGS

Co-engineering, simultaneous engineering, or cooperative engineering: no matter what it is called, the meaning is the same—customers working with forging suppliers to create the optimal metal component. This approach provides benefit to customers and forgers alike.

Essentially, co-engineering encompasses mutual cooperation between customer and forging supplier—from the initial design stage on—to achieve the best combination of manufacturability and ease of assembly, as well as maximum cost-effectiveness. In its widest sense, cooperative engineering also encompasses material selection and conservation, as well as interim processing like heat treating, finishing, and even design of mating parts. The table on the right lists the advantages of cooperative engineering.

### ADVANTAGES OF COOPERATIVE ENGINEERING

- ✓ Shape optimization
- ✓ Weight savings
- ✓ Optimum strength
- ✓ Materials savings
- ✓ Simplified machining (for the customer)
- ✓ Part consolidation
- ✓ Improved dimensional control
- ✓ Closer tolerances
- ✓ Unique design features
- ✓ Streamlined assembly

Cooperative engineering has become easier due to technology. Many forging companies and their customers share and refine CAD and CAM databases to complete new forging designs more quickly and accurately, to produce more accurate dies, to reduce lead times, and to tighten tolerances. Similarly, electronic data transfer is making two-way communication faster, and revisions easier.

A classic example of cooperative engineering is the production of more than 160 parts (all forgings, either redesigns or new designs) as the result of close cooperation between an ambitious forging company and a major manufacturer of agricultural and industrial equipment. In a comprehensive program to reduce costs of hydraulic cylinder components, mounting, and related components, average cost-savings of 50% per component were achieved. A forged part that replaced a cast version is typical of these components. The redesigns and similar new designs replaced machined bar stock, flame-cut plate, and castings. Not surprisingly, newly designed and redesigned forged parts virtually eliminated rework and dramatically increased the number of acceptable parts.

Here are just a few examples co-engineered forgings, developed via close cooperation between manufacturer and forger, and all of which boost performance and lower cost:

- ✓ a stop nut for a pipeline ball valve, forged in one piece to eliminate practically all machining operations;
- ✓ a near-net-shape, forged-steel, automotive steering arm, redesigned from a less reliable three-part weldment (including two stampings);
- ✓ a refined forging design for an industrial-compressor crankshaft that resulted in tighter tolerances via process improvement; and
- ✓ a slack adjuster for truck braking systems that incorporates built-in lugs to eliminate rivet pins, hold drilling and slow assembly.

*Continued*

# FORGING SOLUTIONS CONTINUED

## Timely communication is the key

When should cooperative engineering start? The answer is, the sooner, the better. To get the optimum results through cooperative engineering, early vendor involvement is of prime importance. The more that a potential customer can convey about the part, the better the chances are of attaining a final design configuration with an acceptable cost/performance balance.

Whether new designs, redesigns/conversions, or refinements of existing forging designs are involved in cooperative engineering, communication is the key to creative solutions of both design and manufacturing challenges. Success stories of co-engineered forgings abound in unique, weight-saving part geometries, built-in attachment features for mating parts, part consolidations, cost-effective material substitutions, and innovative design features—all due to effective communication.

While it may be standard practice for some, simply sending an engineering drawing will not cause all pieces of the manufacturing puzzle to fall into place. Even an expert designer may not be aware of all the subsequent operations and details for grinding/machining, required fixturing, assembly, finishing, and so forth to produce a part to final dimensions and tolerances.

A good rule of thumb is to avoid the convenient "make the part to print" approach. Considerations such as alignment of mating parts, assembly sequence, gauging requirements, etc. should be thoroughly examined, then discussed with the forging company.

## Do not forget "What if?" scenarios

Although it is often assumed that subsequent machining and other operations will be more efficient or cost-effective if done in-house (at the customer's facility), cooperative engineering discussions may reveal that many forging companies can perform value-added services that range from rough machining to finishing and even supplying ready-to-install assemblies.

The customer should do subsequent machining or manufacturing when it is cost-efficient to do so. Even in this instance, forging companies can provide the expertise to make operations like machining more cost-effective than ever. A key example of cooperative engineering is the use of target dimensioning or target machining to facilitate metal removal at a customer's plant.

## Target machining

Target machining (or target dimensioning) is just that. It gives forging customers a "target" (benchmark or gauge point) as reference for further machining. This approach prequalifies the part for subsequent machining or other operations, greatly reducing the customer's set up, fixturing expense and overall manufacturing costs for such operations.

This prequalification can be accomplished in various ways, depending on the customer's preference and the forging operations used to manufacture the part. If a part is to be coined as part of the forging sequence, it is a relatively simple matter to incorporate a reference mark at a convenient location. With high-volume production, a separate coining operation may be justified to accomplish this; namely, coining a positive locating feature with a V-die.

Coined locating surfaces and drilled centers are routinely used for such automotive parts as connecting rods, pinions, trunnions, tie rods and other steering gear and suspension components, resulting in certified parts delivered to the customer, thereby eliminating concern that downstream problems will interrupt the manufacturing sequence.

*Continued*

# FORGING SOLUTIONS CONTINUED

A simple approach to target machining is to utilize punched or drilled holes, which then establish the reference or datum plane for all subsequent gauging and machining. If holes are already an intrinsic part of a forged design, such as for attachment of mating parts, the gauge point already exists. If not, holes may be added as long as they do not interfere with part function. In either case, the forging supplier should machine or punch the holes so components are certified before shipping. This removes the burden and expense of gauging and inspection, sometimes amounting to a significant savings for the customer.

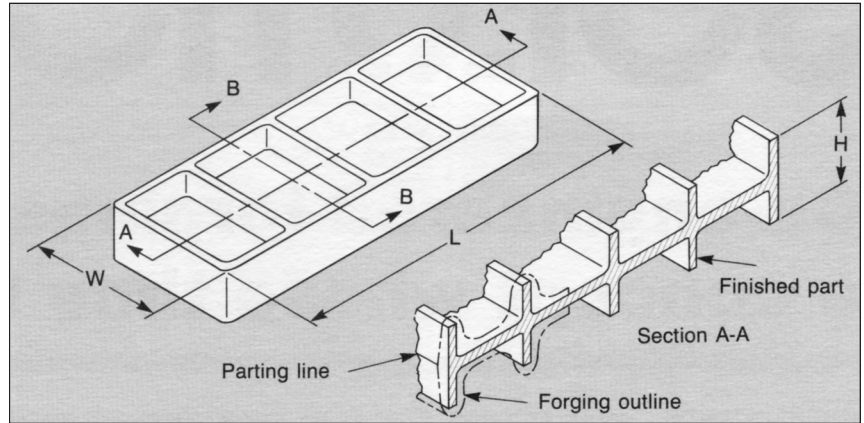

Rib/web structure typical of large aerospace forgings, which undergo extensive machining.

## 'Targets' for large, structural forgings

Cooperative engineering becomes more important when target machining large structural forgings, especially complex rib/web configurations where up to 75% of the weight is removed. See top figure. Such forgings usually require more involved methods than simpler parts and may utilize coordinate measuring machines to maximize accuracy. Both three-point center-drilling operations and six-point fixturing are used to prequalify forgings for machining. Regardless of the method used for target machining, both forging and finished part requirements should be thoroughly discussed with the forging supplier to determine the best way to locate holes or reference points.

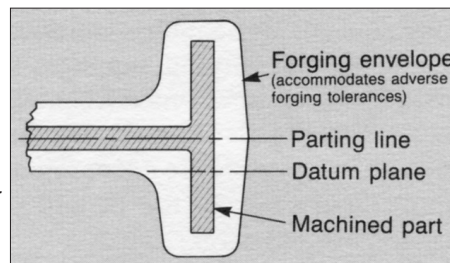

Finished part configuration in relation to as forged outline. Section B-B from figure above.

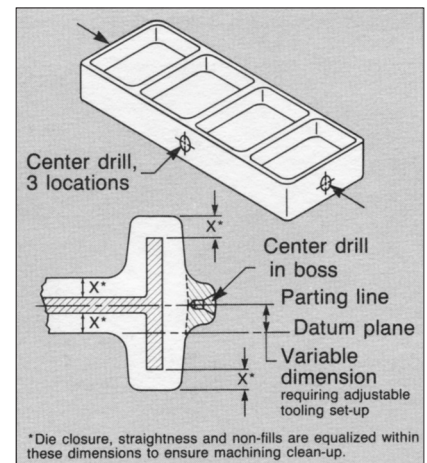

Three hole center drilling (top) accurately locates forgings for machining. Actual forging envelope (bottom) is equalized on adjustable points for center drilling with optimum location.

Three-hole center drilling is not only less expensive than the six-point tooling approach, but can more readily accommodate adjustments. Here, the forger prequalifies the forging by optimizing the final part configuration within the machining envelope, based on the finished part geometry supplied by the customer. See middle figure. Three locating holes, typically drilled in the parting-line area where machining stock is usually at a maximum, indicate the optimum orientation for machining of the forging. If the magnitude of the machining envelope is not sufficient for the depth of the tapered holes, a small boss can be added to the forging. See bottom figure.

These three holes effectively restrain six degrees of freedom (motion and rotation) of the forging, and are usually drilled in the forging while in the qualifying fixture, often matching the customer's machining fixture. (This avoids the extra set-up for milling that is required when tooling pads are used to adjust the forging.)

When implemented, center drilling does not compromise the high standards or tolerances normally associated with forged parts. Overall, three-hole center drilling can often be the most cost-effective alternative, since adjustments can more readily (and less expensively) be made for die mismatch, material shifts (from non-fills and grind-outs), and variations in straightness. In addition, localized surface variations can be offset.

Determining the amount of shift and how the finished part fits within the machining envelope can be done by either

*Continued*

# FORGING SOLUTIONS CONTINUED

of two ways, both of which require checking numerous positions along the forging to accurately locate the center-drilled holes. One method involves the use of templates (identical to the forging's shape), located at a specified stand off distance (e.g., 0.5 in.) beyond the largest forging and takes into account any shifting of the forging. See top figure. Here, two "go/no-go" gauge balls are used.

An even more accurate, but slower, method makes use of dial indicators to measure the gap around the forging. This results in better positioning of the forging within the envelope, effectively optimizing center drilling.

The 6-point tooling method makes use of as-forged external features to orient the forging for machining. See bottom figure. However, this method cannot accommodate shifts of the forging within the machining "envelope" to improve straightness, to allow for die closure and mismatch, or to adjust for excess material on one side of the parting line and non-fill on the opposite side. In practice, some adjustment is possible if raised pads (which are milled down to the proper height) are added to the forging, or if movable tooling points (which require additional set-up time by a machinist) are used. Ordinarily, a forger mills the tooling pads and then ships a "qualified" part to the customer. Consequently, machining operations at the customer's plant can be accomplished by using the tooling points.

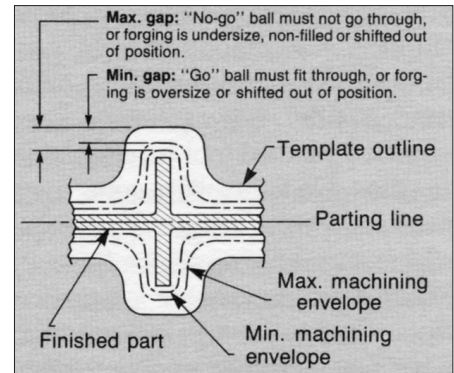

Templates and go/no-go clearance balls—or dial indicators—are used to check forgings prior to center drilling.

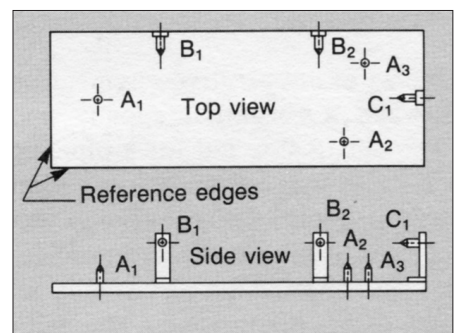

Simple six point fixturing for machining of a forging. In practice, the forging is first set on the three "A" points then moved against the two "B" tooling points, and finally against the "C" point, restraining the part in six degrees of motion (translation and rotation). Clamps hold the forging against the tooling points during the cutting operations.

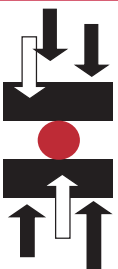

## FORGING INDUSTRY ASSOCIATION

25 West Prospect Ave., Suite 300, Cleveland, OH 44115

Phone: 216-781-6260 Fax: 216-781-0102

E-mail: [info@forging.org](mailto:info@forging.org) Website: [www.forging.org](http://www.forging.org)

# FORGING SOLUTIONS

Addressing these processes:

Impression Die	✓
Open Die	✓
Rolled Ring	✓
Cold	✓

Design Engineering Information From FIA

## FORGINGS SUPERIOR TO CASTINGS DUE TO LONG-TERM PERFORMANCE

It is no surprise that forgings routinely outperform castings in a host of applications. High structural integrity, maximum strength, improved toughness, longer life, and optimum reliability are just a few of the many reasons.

When designers are not sure if a casting will perform, forging is often designated as the alternate process on engineering drawings. In the past, castings were erroneously selected as a first choice, based on the false assumption that they would cost less. Unfortunately, many castings failed to show repeatable performance in service, making the original "select casting for price" approach a moot point. In fact, the extended service life of forgings often makes them less expensive in the long run, even if forgings have a slightly higher initial cost.

When castings are selected as the result of an uninformed decision, rejects, rework, quality problems, and more can create production delays for the OEM customer because metal components cannot be delivered on time. This was the case when a critical tank component was first specified as a centrifugal casting, because forgings were considered noncompetitive with castings from a cost standpoint. In the end, forgings not only outperformed castings, but also delivered an improved design at lower cost.

Although it is generally accepted that castings perform reasonably well under compressive stress, they usually cannot compete with forgings in applications where toughness and durability are the main requirements. In the order of greatest property advantage, forgings routinely outperform castings under impact, shear, and tensile loading.

Castings should not be selected by the designer on the promise of lower initial cost without taking into account such factors as forgings' higher strength-to-weight ratio, which allows reduced section sizes and lighter-weight components. This can be a big contributor to cost effectiveness when implemented in component designs.

Additionally, the initial cost of some forgings can be less than that of cast counterparts when the component is initially and cooperatively designed as a forging. This allows customers and forgers to take full advantage of cost saving design features and manufacturing economics.

Forgings are becoming more cost-competitive with a wider range of cast products as usage of microalloyed steels grows. Forged microalloyed steel can replace ductile iron and ADI (austempered ductile iron) in automobile crankshaft and diesel camshaft applications with cost savings at production volumes. See figure above. Beyond the cost

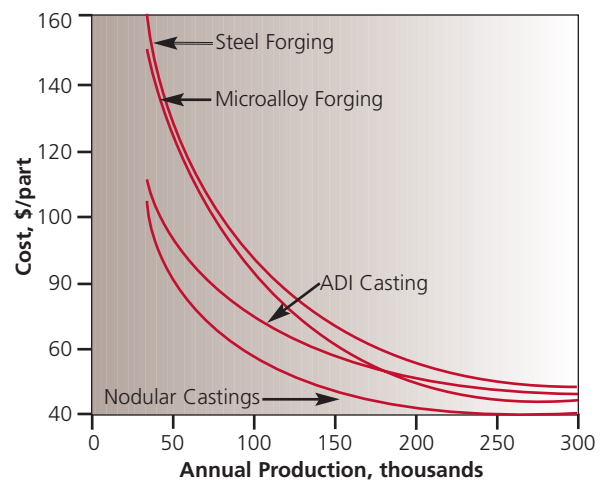

Forged microalloyed steel crankshafts are less expensive than ADI and conventionally forged steel versions and become competitive with nodular irons castings at high production volumes.

*Continued*

# FORGING SOLUTIONS CONTINUED

issue, the main drivers for the change are consumer demand for higher-performance components and the need to meet more stringent EPA regulations and CAFE (corporate average fuel economy) standards.

## ***Advantages of forgings versus castings***

Many impressive characteristics and superior properties allow forgings to outperform castings in a wide variety of applications. The main performance advantages of forgings include:

- *Structural integrity of forgings*, which far surpasses that of castings, makes forgings far less prone to failure. Not infrequently, the inherent discontinuous structure of castings—notably porosity, large inclusions and segregation effects—are commonly the cause for in-service failures. See figure on the right.

In castings, these discontinuities often become sites for stress concentrations, fatigue crack initiation, and finally, catastrophic failure. Examples of forgings replacing casting due to such failures include: a high-temperature steel for high-pressure submarine applications; a 5,000 psi hydraulic component (aluminum die casting leaked); an open-die-forged steel shovel hub for mining (casting cracked); and a critical component for truck brakes (low-strength porous casting prompted safety concerns).

In the aerospace sector, forged stainless and nickel alloys for fuel components of commercial turbines proved that investment castings could not match the inherent quality of forging. This application was actually shown to be as cost-effective as a forging in combination with CNC machining.

Chemical segregation, also associated with casting, is not a significant factor with forgings, which have a very homogeneous microstructure and chemical composition. Because of the amount of reduction performed on ingot or bar during forging, centerline porosity is practically nonexistent.

- *Grain flow optimization*, an intrinsic advantage of forgings, results in orienting the grain structure with a part's geometry, permitting strength to be aligned in the direction of the highest stress which a component will encounter in service. The net effect results in enhanced strength, toughness, fatigue properties, and longer life. Unfortunately, the solidification of castings produces a random grain orientation, which cannot be optimized. Examples where controlled grain flow provides dramatically improved performance over castings include: automotive and truck crankshafts, wheels for all types of vehicles, a 1-ton connecting rod for coal slurry pumps, and dragline chain links for strip mining.

- *Greater strength* in forgings is accomplished through hot-forging reduction, an integral part of forging processes that also helps produce a homogeneous microstructure by eliminating porosity. This allows forging to attain ultimate tensile strengths above 240,000 psi with correspondingly high design strengths; higher, for ultra-high-strength steels and precipitation-hardening stainless steels.

Tremendous improvements in as-cast properties are achieved by this reduction. For example, true stress at failure for quenched and tempered 4140 steel increases from 200,000 psi (as-cast) to 243,000 psi after a 4:1 reduction. In parallel, impact toughness increases by 50%. Such properties are responsible for many forging successes, where castings just cannot handle the loads. Such was the case when sand castings were tried as the main structural components for a missile system—insufficient strength resulted in failure. Fortunately, the forging "alternate" performed within design requirements.

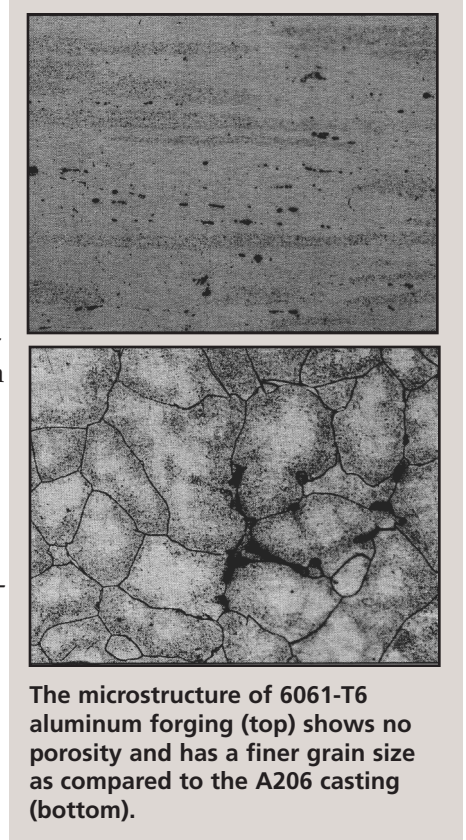

The microstructure of 6061-T6 aluminum forging (top) shows no porosity and has a finer grain size as compared to the A206 casting (bottom).

*Continued*

# FORGING SOLUTIONS CONTINUED

- *Higher design stresses* as compared to castings typify forgings. Up to 75% to 80% of yield strength can be used in design calculations for forgings, but significantly less for castings. Use of design limits 36% higher than cast A27 steel has been reported for rolled-ring forgings made of 1045 steel. Similarly, aircraft component manufacturers, who have looked to forgings for 1/3 more ultimate tensile strength than castings.

- *Improved toughness* is one reason why forgings endure when castings fail. When ductile iron crankshafts failed, while forgings continued to perform, low toughness was suspected. Subsequent Charpy V-notch testing confirmed suspicions. The forged 1045 steel cranks attained greater than 100 ft-lb. values whereas ductile iron, only had 1.5 ft-lb. (see table on the right). Even if more typical 8- to 10 ft-lb. values could be counted on for ductile iron, forgings still have an impressive performance edge.

## COMPARISON OF FORGED VERSUS CAST CRANKSHAFTS\*

Property	Casting	Forging						
Ultimate tensile strength, psi	36,400	102,900						
Yield strength, psi	36,400	78,000						
Elongation, %	0	38.0						
Reduction of area, %	0	63.6						
Charpy V-notch impact, ft-lb								
test @ room temperature	1.5	103.0						
@ -40° F	-	19.0						
@ 300° F	3.0	-						
<b>Chemical analysis, wt. %</b>								
Element	C	Mn	P	S	Si	Ni	Cr	Mo
Cast	3.97	.27	.033	.014	.65	.08	.01	.01
Forged	.45	.66	.019	.049	.24	.12	.24	.09

\* Forged 1045 steel/ductile iron

A property improvement is seen in fracture toughness of rams for forging presses. Here, a greater safety factor is afforded by forged steel. In practice, the high ductility or toughness of forgings is used to advantage in many life-critical applications to provide an additional safety factor in the event design stresses are exceeded in service.

- *Longer service life*, greater fatigue resistance and considerably higher fatigue endurance limits as compared to castings are to be expected. It is not uncommon for life cycles of forgings to be several times that of cast parts. Examples include forged steel coal-pulverizing hammers with five times the life of cast versions and critical parts of pneumatic tools with life time estimates five to ten times greater than cast parts.

Operations such as shot peening, shot-blasting and deep rolling can further enhance the fatigue properties and service lives of forged parts over cast parts. With a forged microalloyed crank, whose fatigue strength was already 57% greater than nodular iron, shot peening boosted that value by another third.

- *Near-isotropic property profile* instead of the more typical directional profile is also possible with forgings. The ability to increase long- and short-transverse properties of steel forgings up to more than 90% of that of the longitudinal direction can be accomplished by special forging techniques (such as upsetting prior to conventional forging or cross-working) and by ladle additions to control shape and size of inclusions.

- *Higher strength-to-weight ratio* of forgings translates into lighter weight parts and reduced sections, compared to castings. Forged-steel automobile connecting rods are 10% lighter, yet stronger than cast counterparts. Other load-bearing parts, such as wheel spindles, cranks and camshafts can yield similar results. When forged aluminum replaced cast iron in brake and suspension components and engine mounts, weight savings as high as 60% were achieved.

Similarly, high-temperature aerospace components, forged of nickel-base alloys and stainless steels, commonly

*Continued*



# FORGING SOLUTIONS CONTINUED

weigh 5% to 10% less than castings. Weight savings for precision aluminum forgings are considerably greater.

As-forged surfaces, built-in design features and thin ribs and webs contribute to such savings, rivaling the near-net-shape capability of any other process including casting. Features such as flanges, ribs and webs all have to be thicker in castings to achieve strength levels of forgings.

- *Surface quality* routinely surpasses that of casting because forgings feature 100% density and homogeneous material throughout. Repair work via welding, which is often required to bring castings up to par in bearing and structural applications, is not necessary with forgings. Denser surfaces (no voids, inclusions, etc.) are a benefit even with non-structural forged parts. For example, forged-brass decorative flagpole tops exhibited a very dense surface - smooth enough to replicate fine details even after subsequent chrome plating, if desired. No porosity problems were found.

- *Improved machinability* also typifies forgings due to a consistent chemical composition and uniform microstructure. Unlike castings, there are no voids, inclusions and segregated hard spots to interfere with machining operations. Many applications in which forgings have shown improved machining over castings have been documented, among them: microalloyed crankshafts, hydraulic components, and rolled-ring forgings. In addition, some free-machining steel grades are routinely forged, thereby improving both the ease and economy of machining.

Many other performance advantages of forgings have been demonstrated time and time again, most of which appear in the accompanying box (see table on the right). While castings do have their application niches as far as metal components go, forging companies believe that the overall higher performance of forged products make them a "must" for critical components. Importantly, even non-critical parts where strength is not the prime issue may become economical as forgings due to extended life cycles.

## ADVANTAGES OF FORGINGS OVER CASTINGS

- ✓ Higher strength
- ✓ Unmatched toughness
- ✓ Longer service life
- ✓ Higher structural integrity (absence of internal defects)
- ✓ Higher design stresses
- ✓ Greater transverse properties
- ✓ Increased safety margin (due to high ductility)
- ✓ Greater strength-to-weight ratio (lighter parts, reduced sections)
- ✓ 100% density (no porosity)
- ✓ Higher overall quality/reliability
- ✓ Reduced product liability concerns
- ✓ Reduced testing requirements
- ✓ More acceptable parts/fewer rejects
- ✓ No welding repair required (uniform consistent material throughout)
- ✓ More predictable heat-treat response
- ✓ More uniform properties (lot to lot, and part to part)
- ✓ Directional or isotropic property profile
- ✓ More consistent machining (uniform microstructure and chemical composition)
- ✓ Better hardness control for abrasion/wear resistance
- ✓ Extended warranties more probable on critical parts/assemblies
- ✓ More versatile processing options and combinations (upsetting, then forging; forging plus coining, etc.)

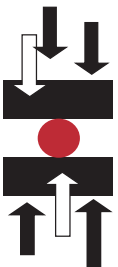

## FORGING INDUSTRY ASSOCIATION

25 West Prospect Ave., Suite 300, Cleveland, OH 44115

Phone: 216-781-6260 Fax: 216-781-0102

E-mail: [info@forging.org](mailto:info@forging.org) Website: [www.forging.org](http://www.forging.org)

# FORGING SOLUTIONS

Addressing these processes:

Impression Die

Open Die

Rolled Ring ✓

Cold

Design Engineering Information From FIA

## FORGED RINGS: THE ULTIMATE IN INTEGRITY AND PROPERTIES

Forged rings represent the best option for any metal component with a ring-like geometry. In practice, the intrinsic advantages of forging are realized, such as optimum structural integrity combined with a maximized property profile. Compared to alternatives like castings, weldments, and flame-cut plate, forged rings deliver higher strength and toughness. These two superior properties translate into longer life for forged ring products, like gears and bearings. In critical applications like solid-rocket motor casings, longitudinal welding proved early on to be of insufficient strength. Only seamless rolled rings can provide the needed properties.

Across the applications board, manufacturers who require the highest reliability in their critical components select forgings for gears, bearings, and other ring-like products in heavy-duty trucks, off-road equipment, mining machinery, ocean-going vessels, aircraft, and energy-generating equipment. High reliability is especially important in safety-critical applications like construction cranes.

Designers have long known that properties of forgings exceed those of other alternatives, and seamless rolled rings are no exception to this rule. For example, large-diameter cast steel gears, which were difficult to machine (wearing out tools at rapid rates), and whose teeth fractured prematurely in service, exhibited strength and toughness values significantly lower than those of forged products. Naturally, the designated solution to this problem was rolled rings. (Property comparisons are shown in table above.)

Producers of forged rings have demonstrated time and again that yield strength is higher and that a more refined structure is achieved when compared to their cast counterparts. Microstructurally, the higher properties of forged rings are the direct result of circumferential grain flow, imparted when a hot metal donut-shaped blank or preform is continually worked into its near finished shape either on a ring-rolling mill or forged over a mandrel. In effect, this orients strength with part geometry so that the forging will perform optimally in service. When contour rolling is utilized to produce an integral flange or more intricate cross-section, the grain flow is then extended into the flange area. Integral flanges are generally preferred to simply machining a flange out of a rectilinear ring.

### PROPERTIES OF FORGED VERSUS CAST RINGS\*

Composition	Yield strength		Tensile strength		Red. of area, %	
	psi		psi			
A (cast)	74,000		108,300		35.0	
A (forged)	88,750		117,500		54.6	
B (cast)	85,750		123,700		32.2	
B (forged)	120,000		141,000		46.2	
C (cast)	80,700		111,800		42.5	
C (forged)	99,000		127,500		52.2	
Comp., %	C	Mn	Si	Cr	Ni	Mo
A:	.42	.72	.42	.00	.17	.02
B:	.42	.70	.42	.57	.12	.02
C:	.43	1.11	.43	.00	.12	.04

\*Important note: Forged specimens actually taken from rolled rings by FIA member co. and tested. Cast data is from ideally oriented keel block specimens, so properties from actual cast rings could be significantly less.

# FORGING SOLUTIONS CONTINUED

While casting results in randomly oriented grain flow, property values of forgings are generally superior in any selected direction. With torch-cut plate, the cutting interrupts the unidirectional grain flow making the part more susceptible to fatigue. No matter how it is fabricated, a ring which incorporates a longitudinal weld has the potential problems of inadequate strength, dimensional distortion (because of the seam) and HAZ (heat-affected zone) effects which can produce regions that are too hard, inclusions, porosity and other defects that affect performance. In practice, a girth weld is preferred over a longitudinal weld, because the stresses in the axial direction are only about half that of the hoop stress to which a longitudinal weld would be subjected.



Rolled steel rings have replaced more costly heavy wall tubing, which was cut to shape and contoured into ring gears.

Rolled rings also can outperform welded parts, cost-wise.

For example, a rolled ring gear-sprocket application replaced a butt-welded product that started with a straight bar that was bent into a circular pattern until the two ends meet, and was then welded. The rolled ring cost significantly less than the welded version, even when the cost of heat-treating was included in the ring price. Similarly, rolled rings have replaced gears made from heavy-wall tubing and have also been cost effective. See figure above.

There are two process options for forged rings: seamless ring rolling and forging rings over a mandrel. Both are usually classified as open-die forging processes. However, certain configurations (usually more complex cross-sections) may be made by a combination of ring rolling and closed-die forging. For example, the basic rolled-ring shape may be put into a die, then hammer or press-forged into a bevel gear or T-section, which is then subsequently machined.

## ***Impressive advantages***

The biggest advantage of forged rings is the ability to make a high-strength, ring-shaped component in one-piece with minimal material loss. Compared to torch-cut plate, up to 50% material savings can be achieved. Not surprisingly, the flame-cut customer will be forced to pay for such material waste. Even when theoretically speaking, a tremendous material loss is associated with cutting plate. See bottom figure.

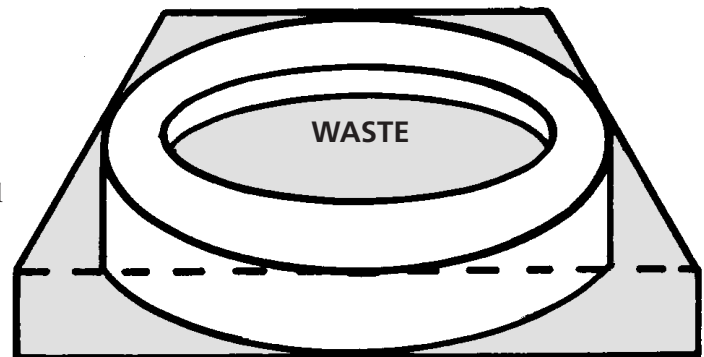

Material conservation for a ring forging is typically 95% as compared to a cutting the ring from a plate.

Before it is rolled, the final ring blank typically weighs about 95% of the starting billet. A minimal loss is attributed to the small hole or web punched in the preform for mounting on the machine. This translates into cost savings over plate due to the material conservation. Contoured rings, whose inner diameters and outer diameters are rolled to shape, also save material by reducing the metal removed by machining. Often, only minimal cleanup or finish machining is needed.

Other advantages of forged rings include: less distortion in heat treatment; predictable and efficient machinability; quicker deliveries than fabrication by extrusion, bending, then welding (aluminum); fast set-ups to accommodate small runs; and close-to-finish cross-sections that can only be achieved by extensive machining. Low tooling costs are also typical with seamless rolled rings, varying slightly with equipment, but especially with a contour on the inner diameter or outer diameter. Generally, inner diameter contouring is readily done, even in

*Continued*

# FORGING SOLUTIONS CONTINUED

short runs. Outer diameter contouring typically must be justified with at least a shift's worth of production, because of the labor cost involved in changing over the main contoured drive roll. With saddle/mandrel set-ups, no tooling cost is involved. Standard tooling of varying size is normally in stock.

Like other forged products, forged rings are also the best in terms of structural integrity. Inclusions, macrosegregation and porosity, which typically detract from the service life of castings for bearing and gearing applications, are not much of a factor with forgings. Similarly, plate may contain laminations and porosity, which also detract from performance. Since forgings do not contain these types of defects, fatigue and service lives of forged products are typically longer.

## ***Large rings, small rings, flat rings, tall rings***

For forged-ring components, size and weight capability is indeed broad. Outer diameters span the gap from a few inches up to about 30 ft. Inner diameters range from just under 2 in. up to the thinnest wall that can be achieved with a maximum outer diameter. However, the majority of rolled rings have outer diameters ranging from about 9 in. to 4 ft. Face heights (widths) go from fractions of an inch up to almost 10 ft. Weight-wise, forged rings range from less than 1 lb. up to more than 300,000 lbs. Because of equipment limitations, the size range of contoured rolled rings is somewhat less.

Basic shapes go from flat-washer configurations to tall thin-walled cylinders (e.g., for motor casings). Typical thickness-to-height ratios range from 16:1 up to 1:16, although special equipment can extend that range.

Typical quantities for seamless rolled rings range from a few pieces up to thousands, depending on their diameter and whether they are contoured or not. In general, saddle/mandrel forging is used to produce rings with heavy wall thicknesses or rings with large face heights and small inner diameters, and usually in smaller quantities.

## ***Contouring closer to net shape***

While a straight rectangular ring is perhaps the simplest shape, contouring of rings makes the number of possible cross-sections and design options virtually limitless. Usually, contoured rings are shaped by rolls specially machined to replicate the inside or outside contours. Savings in materials, machining operations, and secondary processing normally preclude other non-forging process options. Inevitably, many high-reliability, safety-critical components can only be made this way, because required property profiles can only be achieved by forging.

## ***Applications abound***

Application-wise, there seems to be no limit to the success of forged rings, primarily because of their structural integrity, high strength, good toughness, and long life versus competitive components. Very large seamless rolled rings, up to a diameter of 250 in., have routinely replaced both fabrications and castings for riding tires and rollers of rotary kilns and industrial dryers because of their superior performance. Similarly, high-speed gears-made as 120 to 150 in. rolled rings, and then machined-yield high performance in marine propulsion systems for ocean-going vessels, power-generating equipment and rocket-motor casings.

Moderately sized forged rings continue to proliferate in gears and bearings for transmissions, drive trains and wheels for heavy trucks, off-road equipment, locomotives, tractors, and automobiles. Overall, bearing makers find that the wear factor of shaped, rolled rings is considerably better than bearing races cut from tube or from bar.

Cost/performance benefits of forged rings occur in many applications, spanning virtually every industry. Examples include:

- cutter discs, contour ring-rolled with a tapered OD, for boring tunnels through rock, mountains and tunnel work;
- rings for pipe connectors in the oil industry;
- crusher rings for pulverizing coal (which is fed into power-generating systems); alternately for crushing rock or for making granules for roofing shingles; and
- shaped, stainless steel ring molds for palletizing cattle food.

*Continued*

# FORGING SOLUTIONS CONTINUED

## Materials

Materials for rings run the gamut from high-strength and temperature-resistant alloys for aircraft/aerospace applications to carbon and alloy steels for commercial applications. Bearing rings-inners and outers, cups and cones, and spherical bores-are typically made of 52100 alloy. Nonferrous materials include aluminum, copper, titanium, and nickel-based alloys. Among the more exotic materials that are ring-rolled are Inconel 718 and Waspalloy. In short, virtually any forgeable engineering alloy can be manufactured into forged ring shapes.

## Use of technology

Automated manufacturing, statistical problems solving (SPS) and process modeling have been implemented to boost quality, manufacturing efficiency and cost-effectiveness of forged rings.

Automated ring rolling processes have integrated systems in which bar stock is fed into one end and finished rings are ejected on the other. All processing, including intermediate steps of blank making, rolling, sizing, and others, is done automatically. In parallel are forging cells for saddle/mandrel rings where the entire processing sequence, including heat treatment, is controlled from a computer. For both approaches, noteworthy advantages have yielded more consistent dimensions from part to part, higher productivity, and more cost-effective forged products.

Statistical process control (SPC) techniques have been implemented to conserve material, improve processing, and modify equipment for the better, all in the interest of quality improvement and customer savings. Normal-distribution analyses used to reduce stock size of rolled rings are typical of this approach. See figure above.

Process modeling can also be done using finite element analysis to evaluate roll filling and defect formation in profile rings. Such programs can shorten lead and design times, improve quality, and reduce costs of rolled rings.

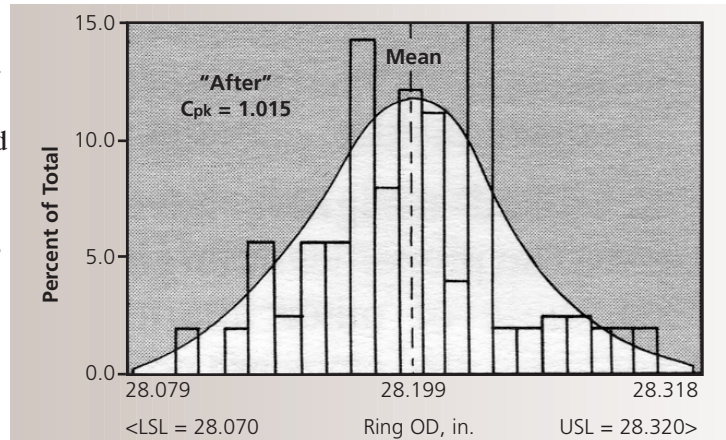

Stock allowances on the inner diameters and outer diameters of a 297 lb. seamless rolled ring were reduced by statistical process control methods. After analyzing the "before" data the ring roller was confident enough in the Cpk (process capability index) to reduce the weight of the 4120 steel rings by more than 9 lbs. The Cpk after the reduction confirmed that the process was still capable.

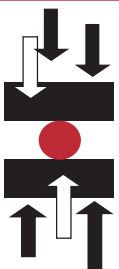

## FORGING INDUSTRY ASSOCIATION

25 West Prospect Ave., Suite 300, Cleveland, OH 44115

Phone: 216-781-6260 Fax: 216-781-0102

E-mail: [info@forging.org](mailto:info@forging.org) Website: [www.forging.org](http://www.forging.org)

# FORGING SOLUTIONS

Addressing these processes:

- Impression Die ✓
- Open Die ✓
- Rolled Ring ✓
- Cold ✓

Design Engineering Information From FIA

## FORGING FUNDAMENTALS: THE KEY TO OPTIMUM DESIGN PRACTICE

To all but the most seasoned designers, the concept of forging fundamentals may at first appear trivial. But that is not the case. In practice, material- and process-related forging basics can be invaluable. For instance, realizing that certain part shapes are more forgeable in some materials and knowing that the equipment affects how closely the material can be forged to its final configuration are just two aspects involved in creating the optimum design.

For experienced designers, forgings are the optimum choice for metal components, even before the design is on the drawing board. Forgings bring superior performance; they have higher strength, unsurpassed toughness, greatest structural integrity, longer service life, and maximum reliability, as compared to castings, stampings, weldments, and machined parts.

Once the correct metal alloy is selected, based on minimum design requirements for mechanical and/or physical properties, in-service environmental conditions, fatigue life, and more, manufacturability becomes a prime consideration. In practice, creating the optimum design for manufacturability takes cooperative effort among the product designer, the forger, and metallurgical personnel.

The manufacturability of a forging design depends primarily on the material being forged, which influences not only the internal soundness of the forging, but also determines important design characteristics and features. These include:

- the amount of finish required;
- the minimum section thicknesses that can be achieved;
- the degree of shape refinement or part complexity;
- the magnitude of tolerances that can be held; and
- size limitations (plan-view area [PVA], length, or width).

**Examining forgeability** (how easy it is to forge a material without rupture) is a good first step toward evaluating manufacturability. This property varies greatly depending on the type of alloy. See figure above. The ability to

*Continued*

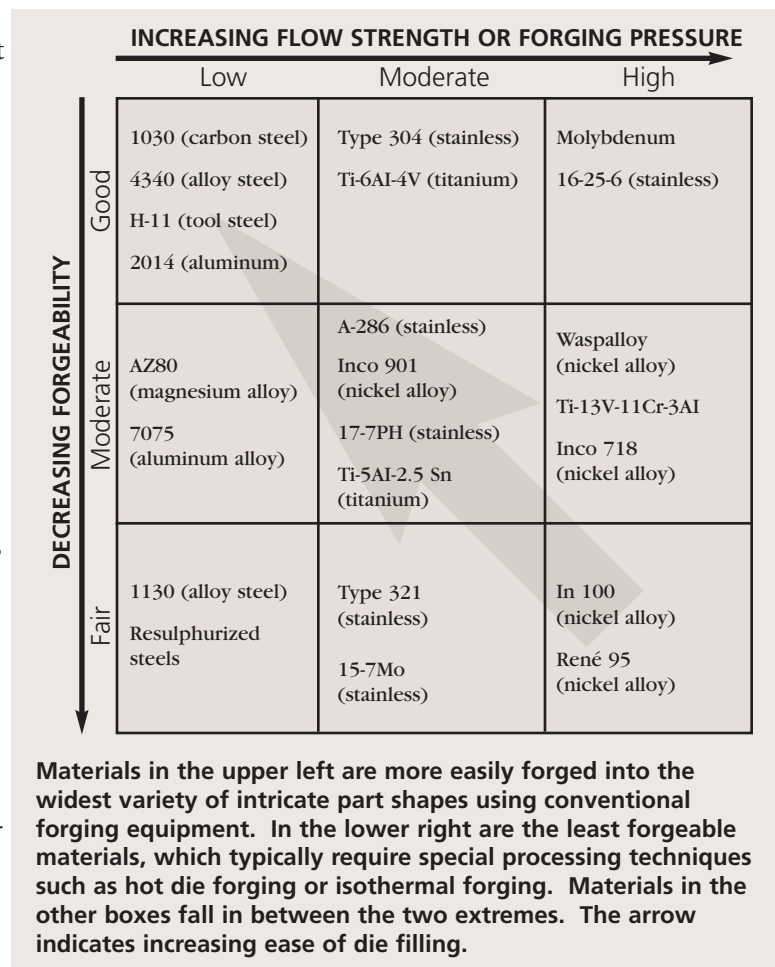

# FORGING SOLUTIONS CONTINUED

manufacture an intricate shape by conventional forging is reflected in how easily a particular material fills a die cavity. Both forgeability and flow strength affect the ease of die filling. In general, high-flow-strength materials are more difficult to fill cavities and usually require higher forging pressures. Inevitably, part complexity also affects forgeability. Typically, more complex designs make a material more difficult to forge. See on the right.

## Material basics

Basic differences between forging materials explains why closer tolerances and more complex shapes are more readily achievable with some alloys. For instance, aluminum forgings can be held to much closer tolerances than steel and provide better shape capability than any other material, with the exception of some copper alloys, forging brasses, and bronzes. Typically, tolerances are about one-third those of steel forgings, due to significantly less shrinkage and reduced die wear. The differences in tolerance and die wear are reflected in the 700-800° F forging temperature range for aluminum versus 1900-2400° F for steels.

In contrast, titanium forgings cannot be held to the same tolerances that carbon- and alloy-steel forgings can because of the abrasiveness of the oxide and other physical factors. Typically, titanium forgings require 20% to 25% greater tolerance than steel forgings.

More exotic materials like superalloys have varying ranges of forging temperatures. Some high-temperature alloys with only a 50 to 60° F forging window have greatly limited forgeability, requiring either hot-die or isothermal forging processes.

## Conventional or precision?

Depending on the material, a variety of processes, either conventional forging or precision forging, can be used to produce the desired shape. Numerous factors help decide what basic process to use. See table above for guidelines on the pre-selection of forging processes for steels.

When forged to near net shape, expensive materials (such as stainless steels, titanium and nickel-base superalloys) become more economical as a result of material savings. However, many common materials (steel, aluminum, etc.) are conventionally forged routinely to more generous dimensions and subsequently machined, but are often more cost-effective than non-forging processes. Frequently, closer-than-normal tolerances can be achieved with conventional forging plus proper ancillary processing, as in the case of a forged aluminum ejector.

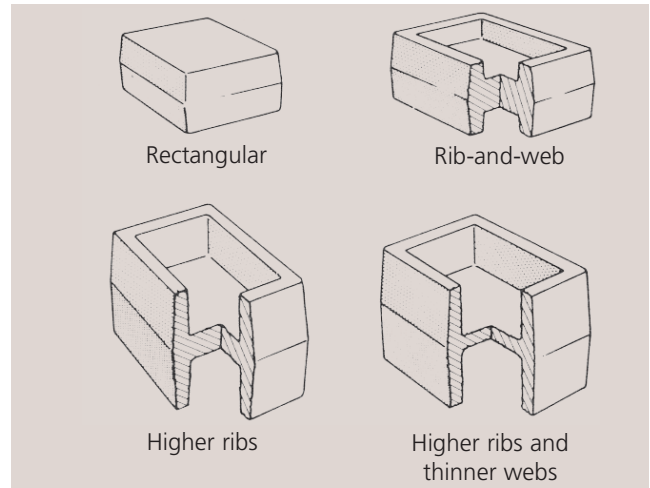

As shapes deviate from basic rectangular configurations, impression die forging becomes more difficult. Parts with thin webs and high ribs are hardest to forge.

## PRESELECTION OF FORGING PROCESSES FOR STEELS

Factors of Choice	Forging processes selection		
	Cold	Warm	Hot
Steel Quality	CWQ	SBQ	SBQ
Material costs	Higher	Medium	Lower
Deformation pressure	Very High	Medium	Low
Energy Costs	Low	Medium	High
Tolerances	Closest	Close	Generous to close
Tooling costs	Highest	High	Lowest
Size range	Smallest (1/4-20lb)	Small to med. (1/2-30 lb)	Virtually unlimited*
Equip. capital**	High	Medium	Lowest
Size/shape restrictions	Limited	Limited	Virtually unlimited

\* Includes open-die forging processes. \*\* Per pound of forging.

Continued

# FORGING SOLUTIONS CONTINUED

Generally, the process selected (and related forging equipment) affects how closely a material can be forged to final dimensions. For example, precision forging of aluminum can yield parts with net-shape surfaces and close tolerances, while conventional forging may require machining all around the part periphery. For higher alloys like superalloys, shape and size limitations become highly equipment-dependent, because of smaller processing windows and the need for precise control of metallurgical factors. As a result, these materials generally require much higher forging pressures than steel, resulting in parts with smaller plan-view areas and other dimensional constraints. In contrast, larger steel forgings can often be produced by utilizing higher capacity (tonnage) equipment. The same holds true for many aluminum alloys.

## ***Near or net shape***

Emphasis is often on forging closer to net shape or as close as possible to finished contours and dimensions. A fundamental knowledge of the following options, which collectively apply to most forgeable materials, helps identify the appropriate process for a given material.

- ***Hot forging in presses*** to near-net shapes is possible for most carbon, alloy, and stainless steels, titanium alloys, heat-resistant alloys, and nonferrous materials. While crank-type drives are more readily automated, screw presses are ideal for thin parts like turbine blades and provide greater thickness accuracy. Both symmetrical and axisymmetrical components can be produced. High production quantities are recommended to offset tool design and development costs. Part weights can approach 200 lbs.
- ***Hot forging in controlled impact hammers*** to near-net shapes applies to most alloys, except for magnesium and higher aluminum alloys, such as 7075, 7079, and 7050. Parts with thin sections and close thickness tolerances are readily manufactured. While lower production quantities are more economical than with presses, shape versatility is not as great since tooling restrictions (lack of kick-outs) requires draft on part designs. Forgings up to about 35 lb. can be produced to near-net configurations (even larger if cold coining is used).
- ***Warm forging in mechanical presses*** to close tolerances is appropriate for steels and some aluminum alloys. Usually requiring progressive forming steps, this process may use automated induction heating to form pre-conditioned steel slugs. For higher productivity, walking-beam transfers are integral with some machines. Suitable for forging gears with integral teeth, warm forging often requires some type of cutting operation to hold concentricity tolerances on shafts. Typically, tooling costs are moderate to high, and sufficient production quantities are needed to justify this process. Maximum part weight is about 30 lbs.
- ***Hot forging in high-speed part formers*** to close finish usually applies to carbon and low-alloy steels, which are typically made into axisymmetrical parts with low profiles. Parts generally feature no draft and very little finish allowance. Although production rates can exceed 100 parts per minute, costly machinery and production-line support equipment requires very large quantities (e.g. automotive) to justify use. Generally, parts weigh up to 15 lbs.
- ***Cold forging*** processes make use of bending, extrusion, coining, etc. to manufacture parts to close tolerances or near-net shapes. All are basically chipless. In practice, ferrous materials are restricted to lower alloy and carbon steels with carbon levels of 0.45% or less; impact extrusions, 0.25% C or less. Although less common, stainless steels and aluminum alloys and bronzes can also be cold forged. Typical shapes include cup- and shift-like parts, struts, and headed components and range from 1/4 to 20 lbs. To justify selection, a minimum of 10,000 lbs. of parts/month is recommended, although there are occasional exceptions to this rough guideline.
- ***Hot-die forging*** in conventional presses requires specialized tooling heated to near-forging temperatures in air. Suitable for titanium alloys and nickel-based superalloys, this process is not recommended for stainless or alloy steels. Most parts are modified disk shapes 6 to 36 in. in diameter and weighing from about 70 to 1000 lbs. Forging of aluminum alloys in heated tools also falls in this category.

*Continued*



# FORGING SOLUTIONS CONTINUED

• ***Isothermal forging*** usually applies to nickel-based superalloys prepared initially by powder-metal compaction. The process is not recommended for steels or stainless steels. Expensive refractory-metal tooling and controlled-atmosphere chambers to protect tools and parts from oxidation are standard. Production rates of a few parts per hour make this process cost-effective for only the highest performance parts. Shapes and sizes are similar to hot-die forging, but with closer tolerances on thickness and somewhat thinner sections.

## ***Size/Shape Limitations***

Shape/size limitations on forging designs are often limited by the equipment used. For instance, aluminum and titanium airframe-type structural components exceeding about 5.5 ft. cannot be forged on many large drop hammers and mechanical presses because the press bed is just not large enough to hold the required tools. Fortunately, large counterblow hammers can handle parts up to 7 ft. long. Beyond that, large hydraulic presses with 50,000 ton capacities can produce components up to 12 ft. long.

However, the total projected area must still be matched to the press capacity. This tends to restrict longer parts to narrower widths (within PVA limitations).

Similarly, disk shapes can be forged of steel on large presses of counterblow hammers up to a maximum 65 in. diameter, but are limited to about 38 in. diameters when forged of nickel-base superalloys, except for simple configurations and fairly thick shapes. The much higher pressures required demonstrate the tie to forgeability (i.e. harder to forge materials restrict plan-view area and overall size, and may also require higher-capacity machines). The number of companies with the largest forging machines is limited.

The features of different forging machines also affect other important design parameters. For example, parts forged in hammers must have draft angles for easy removal from impression dies. The lack of built-in ejection systems makes "no draft" parts impractical. Similarly, multi-section or segmented dies and inserts, which permit such design features as undercuts, lateral protrusions and back draft in aluminum precision forgings, are feasible primarily for hydraulic presses. In practice, such dies cannot be used in hammers or most mechanical presses.

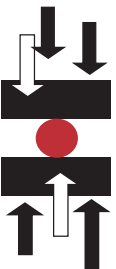

## **FORGING INDUSTRY ASSOCIATION**

25 West Prospect Ave., Suite 300, Cleveland, OH 44115

Phone: 216-781-6260 Fax: 216-781-0102

E-mail: [info@forging.org](mailto:info@forging.org) Website: [www.forging.org](http://www.forging.org)

# FORGING SOLUTIONS

Addressing these processes:

Impression Die	✓
Open Die	✓
Rolled Ring	✓
Cold	✓

Design Engineering Information From FIA

## DESIGN FOR FORGINGS-SPECIFICATIONS HELP

Thinking of specifying a forging? It is probably easier than you think. As is often the case, the reasons why steel castings, flame-cut plate, weldments, machined bar, and others were specified years ago are not necessarily valid or obvious. Informed designers switch to forgings in order to upgrade performance.

There is no need for apprehension if you are only familiar with specifications for casting, structural steel, hot-rolled bar or other non-forged product, because cross-references to existing forgings specifications can often be made. Even when they cannot, forging companies can propose alternatives of an equivalent material, but with typically superior performance.

Some knowledge of pertinent specifications will definitely help those who are not familiar with forgings. This article is intended to present designers and potential customers with preliminary knowledge of forging specifications to expedite the process of upgrading to forgings.

### ***Why specify forgings?***

The answer is simple: Forgings give higher performance compared to castings, machined parts, weldments, and other metal components. This includes high mechanical properties, unsurpassed impact toughness, longer service life, greater structural integrity, a more homogeneous microstructure (freedom from porosity, gross inclusions, etc.), optimum grain flow orientation, and customized property profiles, among others.

Performance is not the only reason. When upgrading from non-forged parts, some forging customers have been pleasantly surprised by an initial lower cost for forgings. While the latter scenario is not always the case, most forgings are actually less expensive when compared to other metal components on a life cycle cost basis. The longer life of high-performance forged components makes it so. A switch to forgings can streamline the manufacturing process. Resulting cost savings can be even more significant. Such was the case when a forging replaced a casting in a friction-welded assembly.

### ***Open die forgings versus non-forged parts***

Because of their higher performance, steel forgings routinely continue to replace steel castings. Knowing what specification to use a particular application to an open die forging is definitely helpful. Although not always simple, cross-referencing commonly used specifications allow designers to more accurately evaluate forging options and actually facilitate the upgrade process. The comparisons of forging specifications to casting specifications appearing in the table on the following page cover carbon and alloy steels for various applications and environmental conditions. This is meant to serve as a guideline only, and is not intended as a final recommendation for any particular application.

One of the most-used open die forging specs available, ASTM A668 is a broad-based starting point for anyone wishing to specify open die forgings (see on the next page for more details). It covers carbon through alloy steels and specifies a definitive Brinell hardness range, among other requirements. It is useful not only for specifying upgrades to forging from casting, but also for other non-forging alternatives. For example, structural steel shapes, plate, and bar previously purchased under ASTM A36 (Standard Specification for Structural Steel) may be cross-referenced to ASTM A668

*Continued*

# FORGING SOLUTIONS CONTINUED

## 'GUIDELINE' SPECIFICATION COMPARISONS: FORGINGS VERSUS CASTINGS\*

Castings:	Forgings:	Forging specification covers:
<i>ASTM A27</i> -Carbon steel castings general application.	<i>ASTM A521</i> -Closed-impresion die steel forgings for general industrial use.	<i>A521</i> : Manufacture, chemical comp, tensile prop., testing, dimensional tolerance req., etc.**
<i>ASTM A148</i> -High-strength steel castings for structural purposes. (Y.S. range: 40-210 ksi; T.S. range: 80-260 ksi.)	<i>ASTM A579</i> -Superstrength alloy steel forgings. (Y.S. range: 140-275 ksi; T.S.: 150-280.)	<i>A579</i> : Manufacture, chemical comp., mech. prop., NDT (mag. particle, liq. penetrant, ultrasonic), Charpy V-notch impact req., etc.** for forged shapes for highly stressed structural members.
<i>ASTM A781</i> - Steel and alloy castings, common requirements for general industrial use.	<i>ASTM A668</i> - Steel forgings, carbon and alloy for general industrial use.  <i>ASTM A181</i> - Carbon steel forgings for general purpose piping.	<i>A668</i> : Chemical comp., mech. prop., hardness, test req. etc. **for: solid forgings (shafts, bars, billets); rings and hollow cylinders; and disks, <i>A181</i> : Materials, manufacture, chem.. comp., mech. prop., test req., etc. for nonstandard as-forged fittings, valve components, general-service parts.
<i>ASTM A487</i> - Steel castings suitable for pressure service.	<i>ASTM A541</i> - Steel forgings, carbon and alloy, quenched and tempered, for pressure-vessel components. <i>ASTM A508</i> - Quenched and tempered, vacuum-treated carbon and alloy steel forgings for pressure vessels. <i>ASTM A372</i> - Carbon and alloy steel forgings for thin-walled pressure vessels. <i>ASTM A105</i> - Carbon steel forgings for piping components in ambient and higher-temperature pressure systems.	<i>A541</i> : Chemical comp., tensile properties, Charpy V-notch impact requirements, etc.** <i>A508</i> : Chemical, mechanical, tensile, Charpy impact, NDT req., etc. **for vessel closures, shells, flanges, rings, etc. <i>A372</i> : Chemical, mechanical req. for bored and hollow forgings; also, bending properties, mag. particle, etc.** <i>A105</i> : Materials, manufacture, heat treat, chem. comp., mech. prop., hydrostatic test req. etc.** for flanges, fittings, valves and similar parts.
<i>ASTM A389</i> - Alloy steel castings, specially heat-treated, for pressure-containing parts. Suitable for high temperature service.	<i>ASTM A336</i> - Alloy steel forgings for pressure and high-temperature parts.  <i>ASTM A182</i> - Forged or rolled alloy-steel pipe flanges, forged fittings, valves and parts for high-temperature service.	<i>A336</i> : Chem. comp., tensile prop., heat treat, test, grain size, etc. **for boilers, press. vessels, high-temp. parts. <i>A182</i> : Manufacture, heat treat, chem. comp., prop., hardness, etc.** for piping components pressure systems (flanges, fittings, valves).
<i>ASTM A217</i> - Steel castings, martensitic stainless and alloy, for pressure containing parts; suitable for high-temp. service.	<i>ASTM A565</i> - Martensitic stainless steel bars, forgings and forging stock for high-temperature service. <i>ASTM A182</i> - Forged or rolled alloy-steel pipe flanges, forged fittings, valves and parts for high-temperature service.	<i>A565</i> : Chemical comp., mech. prop., heat treat, metallurgical req., etc. for chromium steel for high-temp. Max. 1200° F service; for oxidation resist. at low stresses, up to 1450° F  <i>A182</i> : See same, referenced in block above.
<i>ASTM A352</i> - Steel castings, ferritic and martensitic, for pressure-containing parts; suitable for low-temperature service.	<i>ASTM A350</i> - Forgings, carbon and low-alloy steel, requiring notch toughness testing for piping components.  <i>ASTM A727</i> - Carbon steel forgings for piping components with inherent notch toughness.	<i>A350</i> : Manufacture, heat treat, chem. comp., mech. and impact prop., hardness, testing, etc. **for forged or ring-rolled flanges, fittings, valves for low-temp. service. <i>A727</i> : Materials, manufacture, heat treat, chem. comp., tensile, hydrostatic test req., etc. ** for forgings in service from -20 to 650° F

\* Based on standard specifications issued by ASTM (American Society for Testing and Materials), Philadelphia, PA.

\*\* Plus optional supplementary requirements.

Continued

# FORGING SOLUTIONS CONTINUED

Class D, which calls out tensile requirements as a function of size.

In addition to upgrading for performance reasons, such components as thick-walled tubing, flat bar, plate, hollows, etc. often become forgings because the desired stock sizes of non-forged products are not available. Typically, dimensions such as length, outside diameter, wall thickness, etc. are not as limited in forged products, thereby increasing design flexibility.

Similarly, seamless tubing purchased under ASTM A106-91 (Seamless Carbon Steel Pipe for High-Temperature Service) may be specified as a forging under A105 (Standard Specification for Forgings, Carbon Steel, for Piping Components). This option is sometimes preferred for short runs of hollow seamless rounds in short lengths, namely forged or rolled rings.

## **Impression die forgings**

As with open die counterparts, existing specifications for impression die forgings provide a relatively easy way to initiate an upgrade. Targeted at impression die forgings in general, ASTM A521 covers untreated carbon steel forgings up through normalized and quenched-and-tempered alloy steel forgings, detailing most of the design parameters that help make forgings the metal component leader. A good starting point for those not as familiar with forgings, this comprehensive specification includes key requirements for chemical composition, mechanical properties, testing, and dimensional tolerances—length/width, die wear, die closure, die match, flash extension, straightness, surface, draft angle, and finish allowance. When applications so demand, supplementary requirements—magnetic particle, grain flow, impact, microstructural, ultrasonic, radiographic, and Brinell hardness—can be specified. The specification also separately addresses forgings made on hammers/presses or on forging machines (upsetters). This general specification also appears in the previous table.

Greater ductility, reflected in significant toughness improvements, is definitely an important factor in the resulting superior performance of forgings. As is almost always the case, this improvement is indicated by higher percent-elongation and reduction-of-area values for forged versus non-forged products. The table on the right compares minimum specification values for impression die forging versus casting. The clear advantage that forgings typically possess is readily seen in the calculated percentage gains.

It is estimated that there are hundreds of forging-related ASTM specifications, any of which may be useful for a particular application. Beyond "general" specifications, others cover various applications by end use category (rail, air, automotive); by environmental conditions (high temperature, pressure, low temperature); and even by

*Continued*

### MIN. ELONGATION, RED, OF AREA FOR IMPRESSION DIE FORGINGS VERSUS CASTINGS\*

ASTM spec	Grade or Class	Elong. %	Gain % elong.	Red. of area, %	Gain, R of A	Ten./Yield str., ksi	Thick, in.**
A148 <sup>c</sup> Casting	115-95	14	—	30	—	115/95	—
A521 <sup>b</sup> Impression die forging	<u>AE</u> <sup>c</sup>	16	14%	50	67%	125/105	<4
		16	14%	45	50%	115/96	4-7
A148 <sup>c</sup> Casting	90-60	20	—	40	—	90/60	—
A521 <sup>b</sup> Impression die forging	<u>AC</u> <sup>d</sup>	22	10%	44	10%	90/60	<7
A148 <sup>c</sup> Casting	80-40	18	—	30	—	80/40	—
A521 <sup>b</sup> Impression die forging	<u>CE</u> <sup>e</sup>	22	22%	36	20%	80/40	<8
A27 <sup>f</sup> Casting	70-36 <sup>g</sup>	22	—	30	—	70/36	—
	70-40 <sup>h</sup>	22	—	30	—	70/40	—
A521 <sup>b</sup> Impression die forging	<u>CE</u>	24	9%	40	33%	75/37	<8

\*Selected values for cited specs. Issued by American Society for Testing and Materials, Philadelphia, PA. Based on equivalent tensile and yield strengths.

\*\*Or solid diameter.

<sup>a</sup>Standard specification for high strength steel castings for structural purposes.

<sup>b</sup>Standard specification for closed-impression die steel forgings for general industrial use.

<sup>c</sup>Alloy steel, normalized, quenched and tempered

<sup>d</sup>Alloy steel, normalized and tempered.

<sup>e</sup>Carbon steel, normalized and tempered.

<sup>f</sup>Standard specification for carbon steel castings for gen. application.

<sup>g</sup>0.35% C max., 0.7% Mn max.

<sup>h</sup>0.25% C, 1.20% Mn max

<sup>i</sup>Carbon steel: annealed, normalized or normalized and tempered.

# FORGING SOLUTIONS CONTINUED

the exact component type (steel rolls for paper machinery, nonmagnetic retaining rings for generators, rings for reduction gears).

In addition, depending on the end use, a variety of standard specifications, for example: ASTM, MIL, QQ(Federal), SAE, ANSI, AMS, ISO, DIN, JIS, etc., may apply to a particular application. Some overlap; some do not. While this may seem to complicate the upgrade process, a knowledgeable forging company can usually answer specifications questions.

No single specification covers all situations. That is why specifications from ASTM and other standards organizations often include supplemental requirements. Such requirements are negotiable between forger and customer, and can be tailored to fulfill specialized needs and unusual performance requirements.

## ***Practice versus theory***

In reality, a one-to-one cross-reference of a forging specification to a non-forging specification is not always possible. Sometimes, it seems like comparing apples to oranges. But, there is no need to despair. If a part has previously been specified as a casting, machined round bar or other non-forged product, forging companies can offer a viable and economical forging option: namely, a forging that corresponds both compositionally and property-wise to the non-forged product in question. If a casting was previously made to a certain class or grade of material in a cited specification—for example, a 70 ksi tensile strength and 30 ksi yield—these properties can be readily accommodated in an equivalent forging material. As a matter of course, improved properties, greater structural integrity, and longer service life routinely accompany the choice of a forged alternative.

If you know what design criteria (mechanical properties, impact toughness, fatigue life, endurance limit, environmental conditions, etc.) are needed for your application, so much the better. If not, then discuss forging alternatives with FIA members who are more than happy to assist in evaluating your application and present you with options, which may be just what you are looking for, both economically and performance-wise.

When upgrading, keep in mind that some "caveats" may apply.

1) Forgings should not be produced to casting, structural steel, or other metal-component specifications, because each non-forged alternative has its own special inherent requirements that do not usually apply to forgings. While forging companies can provide forgings to meet or surpass chemical compositions and mechanical properties of non-forging specifications, it definitely makes sense to optimize your particular application.

2) Do not inadvertently switch from a casting or other non-forging spec without thorough review of what the requirements entail. Special requirements like ultrasonic testing, which may not be necessary for a particular application, can be automatically invoked by citing a particular specification. When not needed, this just drives up product cost.

3) Do not try to modify existing non-forging specifications. It is usually not feasible and could be counter-productive. Forging companies suggest that you spend this time contacting them with the details on your potential forging application. They can then suggest a forging alternative to your current non-forged product.

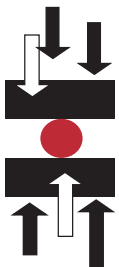

## **FORGING INDUSTRY ASSOCIATION**

25 West Prospect Ave., Suite 300, Cleveland, OH 44115

Phone: 216-781-6260 Fax: 216-781-0102

E-mail: [info@forging.org](mailto:info@forging.org) Website: [www.forging.org](http://www.forging.org)

# FORGING SOLUTIONS

Addressing these processes:

Impression Die	✓
Open Die	✓
Rolled Ring	✓
Cold	✓

Design Engineering Information From FIA

## THE LANGUAGE OF FORGING: KEY TERMS AND DEFINITIONS

Like other technical fields and engineering disciplines, forging technology has a language all its own. Knowing what these terms mean and how they are applied can be of enormous help in seeking quotations, specifying forged products over other alternatives, and understanding why forged components deliver superior performance over non-forged parts.

General metallurgical and other terms not related explicitly to forging are not covered. Not all terms can be covered; only the most common terms are presented.

**Aluminum precision forging:** a process to plastically deform an aluminum alloy to a finished part shape in special dies. By design, little or no subsequent machining/processing is required as a result of close tolerances, thin sections, small radii and minimum draft angles.

**Alloy steel forging:** once made from a steel containing additional alloying elements other than carbon (e.g. Ni, Cr, Mo) to enhance physical and mechanical properties and/or heat-treat response.

**Bar:** a section hot rolled from a billet to a round, square, rectangular, hexagonal or other shape with a cross-section less than 16 sq.in.

**Billet:** a semi-finished section (width less than twice the thickness), hot rolled from a metal ingot, generally having a cross-section ranging from 16 to 64 in<sup>2</sup>. Also applies to a hot-worked forged, rolled or extruded round or square.

**Blank:** raw material or forging stock from which a forging is made.

**Bloom:** same as a billet, but with a cross-sectional area greater than 36 in<sup>2</sup>.

**Blocker-type forging:** one with the general shape of the final configuration, but featuring a generous finish allowance, large radii, etc.

**Carbon steel forging:** one made from steel whose major alloying element, carbon, produces the resultant properties and hardness.

**Close-tolerance forging:** one held to closer-than-conventional dimensional tolerances.

**Closed die forging:** see impression die forging.

**Coining:** a post-forging process for hot or cold parts to attain closer tolerances or improved surfaces.

**Cold-coined forging:** one that is re-struck cold to improve selected tolerances or reduce a specific section thickness.

**Cold forging:** various forging processes conducted at or near ambient temperature to produce metal components to close tolerances and net-shape. These include bending, cold drawing, cold heading, coining, extrusion (forward or backward), punching, thread rolling, and others.

**Cold heading:** plastically deforming metal at ambient temperatures to increase the cross-sectional area of the stock (either solid bar or tubing) at one or more points along the longitudinal axis. See Figure 1.

**Cold working:** imparting plastic deformation to a metal or alloy at a temperature below recrystallization to produce hardness and strength increases via strain hardening.

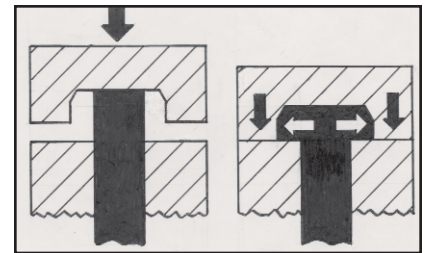

Figure 1. Cold heading or upsetting is a cold forging process where steel is gathered in the head and in other locations along the length of the part, if required. Metal flows at right angles to the ram force, increasing diameter and reducing length.

Continued

# FORGING SOLUTIONS CONTINUED

**Controlled cooling:** process used to attain required properties and/or corresponding microstructural phase changes; applies to heat-treatable steels (e.g. quenching) and to microalloyed steels, which require no heat treatment, but only controlled cooling to attain final properties.

**Conventional forging:** one that, by design, requires a specified amount of finish (or machining) to reach the final dimensional requirements.

**Counterblow forging:** one made by equipment incorporating two opposed rams, which simultaneously strike repeated blows on the work piece.

**Cross forging:** the practice of working stock in one or more directions to make resultant properties more isotropic (equal in three directions), for example, by upsetting and redrawing the material.

**Directional properties:** refers to the inherent directionality within a forging such that properties are optimally oriented to do the most good under in-service conditions. Typically, maximum strength is oriented along the axis that will experience the highest loads.

**Disk:** a "pancake" shaped forging (flat with a round cross-section), such as a blank for gears, rings, and flanged hubs.

**Draft:** the necessary taper on the side of a forging to allow removal from the dies; also applies to the die impression. Commonly expressed in degrees as the draft angle.

**Draftless forging:** a forging with zero draft on vertical walls.

**Drawing:** 1) reducing the cross-section of forging stock while simultaneously increasing the length; 2) in heat treating, the same as tempering.

**Drop forging:** one produced by hammering metal in a drop hammer between impression dies.

**Extrusion:** forcing metal through a die orifice in the same direction as the applied force (forward extrusion) or in the opposite direction (backward extrusion). See Figure 2.

**Finish:** 1) the material remaining after forging that is machined away to produce the final part; 2) the surface condition of a forging after machining.

**Finish all over (F.A.O.):** designates that forgings be made sufficiently larger than dimensions shown to permit machining on all surfaces to given sizes.

**Finish allowance:** amount of stock left on the surface of a forging to be removed by subsequent machining.

**Flash:** excess metal that extends out from the body of the forging to ensure complete filling of the finishing impressions.

**Flashless forging:** "true" closed die forging in which metal deformed in a die cavity permits virtually no excess metal to escape.

**Flow lines:** patterns that reveal how the grain structure follows the direction of working in a forging.

**Forgeability:** relative ability of a material to deform without failure or fracture.

**Forging reduction:** ratio of the cross sectional area before and after forging; sometimes refers to percentage reduction in thickness.

**Forging stock:** wrought rod, bar, or piece used as the raw material or stock in forging.

**Free machining steel forgings:** those made from steels with special alloying-element additions to facilitate machining.

**Grain flow:** fiber-like lines that show (via macroscopic etching) the orientation of the microstructural grain pattern of forgings achieved by working during forging processes. Optimizing grain flow orientation maximizes mechanical properties.

**Hammer forging:** one produced on a forging hammer, usually between impression dies but sometimes flat dies; the process of forging in a drop hammer (see drop forging).

**Hand forging:** one made by manually controlled manipulation in a press without impression dies, usually between flat dies with progressive forging of the work piece; also referred to as flat die forging.

**Heat treatment:** heating or cooling operations, sometimes isothermal, to produce desired properties in forgings.

**High energy rate forging (HERF):** forgings made on equipment that utilizes very high ram velocities.

**Hogout:** product machined from bar, plate, slab, or other material.

**Hollow forging:** a cylindrical open die forging; namely, thick-walled tubes or rings. See Figure 3 on the next page.

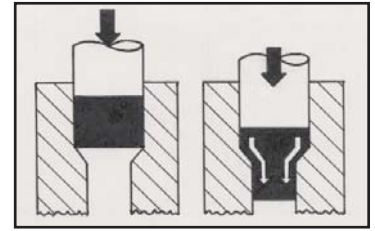

Figure 2. Forward extrusion, a basic cold forging process, reduces slug diameter while increasing length. Stepped shafts and cylinders are typical examples of this process.

# FORGING SOLUTIONS CONTINUED

**Hot die forging:** a process in which dies are heated close to the forging temperature of the alloy being forged; used for difficult-to-forge alloys.

**Hot forging:** same as hot working-plastically deforming an alloy at a temperature above its recrystallization point, i.e. high enough to avoid strain hardening.

**Hub:** a boss in the center of a forging that forms an integral part of the body.

**Impact extrusion:** a reverse extrusion process in which metal is displaced backwards between a punch and a die to form a hollow part. See Figure 4.

**Impression die forging:** one formed to shape and size in die cavities or impressions; also commonly referred to as closed die forging. See Figure 5.

**Isothermal forging** is most commonly conducted at about 2000° F under a controlled atmosphere or vacuum to prevent oxidation while forging superalloys.

**Machine forging (upsetter forging):** one made in a forging machine or upsetter, in which a horizontally moving die in the ram forces the alloy into the die cavities.

**Mandrel forging:** see saddle/mandrel forging.

**Match:** aligning a point in one die half with the corresponding point in the opposite die half.

**Microalloyed steel forging:** one made from a microalloyed steel requiring only controlled cooling to reach optimum properties, which is in contrast to conventional quenched-and-tempered steels that require traditional heat treatments to achieve the same results.

**Microstructure:** the microscopic structure of metals/alloys as seen on a mounted, ground, polished, and etched specimen to reveal grain size, constituent phases, etc.

**Near-net-shape forging:** forging components as close as possible to the required dimensions of the finished part.

**Open die forging:** one produced by working between flat or simply contoured dies by repetitive strokes and continuous manipulation of the work piece; sometimes called hand forging. See Figures 6 to 8.

**Parting line:** the plane that divides the two die halves used in forging; also applies to the resulting forging and impression dies.

**Piercing:** forming or enlarging a hold via a tapered or cylindrical punch.

**Plastic deformation:** permanent distortion of a material without fracturing it.

**Plate:** a flat hot rolled metal or alloy product whose thickness is much less than its width.

**Precision forging:** any forging process that produces parts to closer tolerances than conventional forging processes.

**Preform:** forging operation in which stock is preformed or shaped to a predetermined size and contour prior to subsequent die forging operations; also, ring blanks of a specific shape for profile (contour) ring rolling.

**Press forging:** the shaping of metal between dies on a mechanical or hydraulic press.

**Quenched and tempered steel forging:** one that is quenched and tempered to produce the required hardness and properties; should more accurately be referred to as hardened-and-tempered. (Hardening and tempering are heat treatments that follow austenitizing, which is usually the first heat treatment performed on carbon and alloy steel forgings.)

**Restriking:** a salvage operation following a primary forging operation-rehitting forgings in the same die in which they were last forged.

**Rib:** a forged wall or vertical section generally projecting in a direction parallel to the ram stroke.

**Rib and web forging:** one whose basic configuration consists of ribs and webs.

**Ring rolling:** forming seamless rings from pierced discs or thick-walled, ring-shaped blanks between rolls that control wall thickness, ring diameter, height and contour.

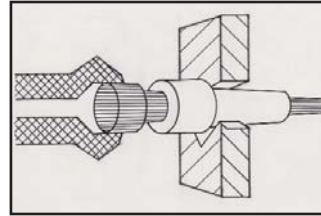

Figure 3. Hollow die forging is an open die forging option, which starts with a punched or pierced disk on a tapered draw bar. Progressive reduction of the outside diameter increases the overall length of the sleeve, while the inside diameter remains constant.

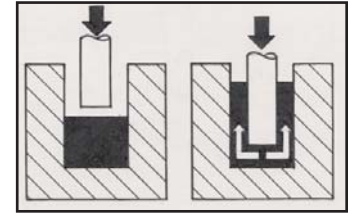

Figure 4. Impact extrusion, another cold forging process, produces hollow parts. Here, the metal flows back around the descending ram.

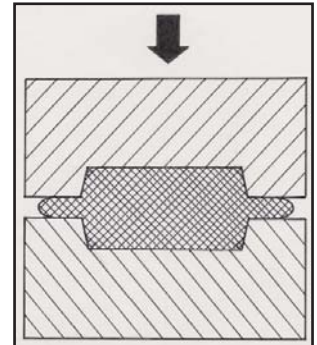

Figure 5. In impression die forging, a workpiece is plastically deformed between two dies filling the die cavity. A small amount of material of "flash" that flows outside the die impression cools rapidly, creating resistance that facilitates material flow into unfilled impressions.



# FORGING SOLUTIONS CONTINUED

**Roll forging:** shaping stock between power driven rolls that incorporate contoured dies; used for preforming and to produce finished parts. See Figure 9.

**Rough machining:** an initial machining operation that leaves adequate stock for subsequent finish machining.

**Saddle/mandrel forging:** rolling and forging a pierced disc over a mandrel to yield a seamless ring or tube.

**Slab:** a flat shaped semi-finished, rolled metal ingot with a width not less than 10 in. and a cross sectional area not less than 16 in<sup>2</sup>.

**Standard tolerance:** an established tolerance for a certain class of product; preferred over "commercial" or "published" tolerance.

**Straightening:** a finishing operation for correcting misalignment in a forging or between different sections of a forging.

**Structural integrity:** inherent microstructural soundness of forgings as a result of achieving 100% density, uniform metallurgical structure and grain size, as well as the absence of porosity, segregation, large inclusions and other non-forged part defects.

**Swaging:** reducing the size of forging stock; alternately, forging in semi-contoured dies to lengthen a blank.

**Target machining:** incorporating a "target" (benchmark or gauge point) on a forging to facilitate machining; coined locating surfaces and drilled centers are commonly used.

**Tolerance:** the specified permissible deviation from a specified or nominal dimension; the permissible variation in the size of a part.

**Trimming:** performed hot or cold, the mechanical shearing of flash or excess material from a forging by use of a trimmer in a trim press.

**Upset forging:** one made by upset of an appropriate length of bar, billet, or bloom; working metal to increase the cross-sectional area of a portion or all of the stock.

**Upsetter (forging machine):** a machine with horizontal action used to produce upset forgings. See Figure 10.

**Warm forging:** forging of steel at temperatures ranging from about 100° F to just below the normal hot working range of 1900 to 2300° F

**Web:** a relatively flat, thin portion of a forging, generally parallel to the forging plane, that connects ribs and bosses.

**Wide tolerance:** any special tolerance wider than "standard."

Space constraints make it impossible to include all terms and definitions that apply to forging processes. For a more comprehensive listing, please refer to the glossary of the *Forging Handbook*.

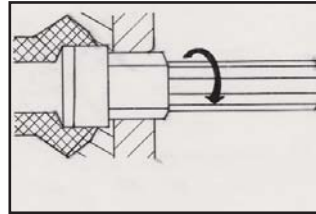

Figure 6. Open die forging of shafts consists of manipulating the sock and progressively forging the component to shape. Turning on a lathe brings the shaft to near net shape.

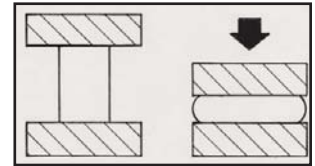

Figure 7. Open die forging of disk shapes involves progressive upsetting/forging to reach desired dimensions. Pierced disks are often used as preforms for saddle/mandrel rings and hollow forgings.

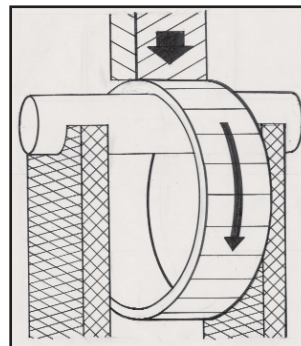

Figure 8. Open die forging of rings starts with a preform on a saddle/mandrel. Progressive reduction of the wall thickness to increase the diameter achieves the required dimensions. Subsequent machining delivers near net shape.

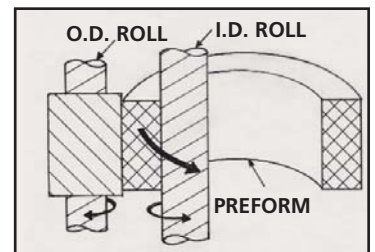

Figure 9. Seamless ring rolling starts with a donut shaped preform, which is squeezed between a free truing I.D. roll and a driven O.D. roll. The ring mill makes the section thinner while increasing the ring diameter.

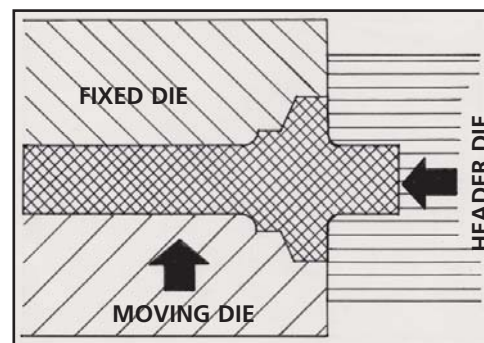
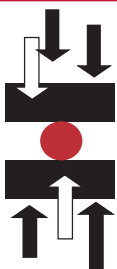

Figure 10. Upsetters or horizontal forging machines produce impression die forgings similar to those made on hammers or presses. "Grip dies" (the fixed die and the moving die) correspond to the bottom die on a hammer or press. The ram operated header die corresponds to the top die on a hammer or press.



## FORGING INDUSTRY ASSOCIATION

25 West Prospect Ave., Suite 300, Cleveland, OH 44115

Phone: 216-781-6260 Fax: 216-781-0102

E-mail: [info@forging.org](mailto:info@forging.org) Website: [www.forging.org](http://www.forging.org)