

Form No.  
918095  
Revision B

# 80 Series

## Variable Chamber Round Balers



# OPERATOR'S MANUAL

**GEHL® AGRICULTURE**



**GEHL**  
**NEW AGRICULTURAL EQUIPMENT**  
**ROUND BALER**  
**WARRANTY**

**GEHL AGRICULTURE DIVISION** of the **GEHL COMPANY**, hereinafter referred to as Gehl, warrants new Gehl Round Balers and attachments, to the Original Retail Purchaser to be free from defects in material and workmanship for a period of twelve (12) months {ninety (90) days for commercial/custom use} from the Warranty Start Date.

**GEHL AGRICULTURE WARRANTY INCLUDES:**

Genuine Gehl parts and labor costs required to repair or replace equipment at the selling dealer's business location.

---

**GEHL MAKES NO REPRESENTATIONS OR WARRANTIES OF ANY KIND, EXPRESS OR IMPLIED (INCLUDING THE IMPLIED WARRANTIES OF MERCHANTABILITY AND FITNESS FOR PARTICULAR PURPOSE), EXCEPT AS EXPRESSLY STATED IN THIS WARRANTY STATEMENT.**

---

**GEHL WARRANTY DOES NOT INCLUDE:**

1. Transportation to selling dealer's business location or, at the option of the Original Retail Purchaser, the cost of a service call.
2. Used equipment.
3. Components covered by their own non-Gehl warranties, such as tires, trade accessories and engines.
4. Normal maintenance service and expendable, high wear items.
5. Repairs or adjustments caused by: improper use; non-intended use; failure to follow recommended maintenance procedures; use of unauthorized attachments; accident or other casualty.
6. Liability for incidental or consequential damages of any type, including, but not limited to lost profits or expenses of acquiring replacement equipment.

No agent, employee or representative of Gehl has any authority to bind Gehl to any warranty except as specifically set forth herein. Any of these limitations excluded by local law shall be deemed deleted from this warranty; all other terms will continue to apply.



# TABLE OF CONTENTS

Warranty .....	Inside Front Cover	Chapter 6	
Chapter 1		Care & Maintenance .....	47-82
Introduction .....	2	Adjustments .....	47
Chapter 2		Lubrication .....	61
Specifications .....	3-4	Service .....	67
Chapter 3		Chapter 7	
Checklists .....	5-7	Storage .....	83
<b>Chapter 4</b>		Chapter 8	
<b>Safety .....</b>	<b>8-19</b>	Troubleshooting .....	84-92
Chapter 5		Chapter 9	
Operation .....	20-46	Optional Features & Accessories ..	93-95
How Baler Functions .....	20	Chapter 10	
Safety Equipment .....	20	Decal Locations .....	96-103
Preparing Baler For Field Operation	25	Chapter 11	
Typical Baling Cycle .....	31	Maintenance Log .....	104-106
Operating Optional Equipment ....	41	Index .....	107-108
Transporting .....	45	Notes .....	109-111
		Hydraulic Fitting Data .....	112
		Standard Hardware	
		Torque Data .....	Inside Back Cover

# CHAPTER 1

## INTRODUCTION

Thank you for purchasing this piece of Gehl equipment. We are sure that your decision was carefully considered and that you are looking forward to many years of work from this machine.

We, as a company, have invested much time and effort in developing our lines of equipment. The equipment you have purchased is built with a great deal of pride and designed to give you long life, efficient operation, durability and dependability.

**Modern machinery has become more sophisticated and, with that in mind, Gehl Company asks that you read and understand the contents of this manual COMPLETELY and become familiar with your new machine, BEFORE attempting to operate it.**

This manual was developed specifically for the machine you have purchased. The information within is for your assistance in preparing, adjusting, maintaining and servicing your machine. More importantly, this manual provides an operating plan for safe and proper use of your machine. Major points of safe operation are detailed in the **SAFETY** chapter of this manual. Refer to the Table of Contents for an outline (by chapters) of this manual. Use the Index, located at the back of this manual, for specific chapter and topic/page number references.

This Gehl equipment is provided with a pocket on the inside of the left twinebox for storing the Operator's Manual and Parts Manual. After using the manuals, please return them to the pocket and keep them with the unit at all times!

If this machine is resold, Gehl Company recommends that this manual be given to the new owner.

If this machine was purchased "used," or if the owner's address has changed, please provide your Gehl dealer or Gehl Company Service Dept. with the owner's name and current address, along with the machine model and serial number. This will allow the registered owner information to be updated, so that the owner can be notified directly in case of an important product issue, such as a safety update program.

The Gehl dealer organization stands ready to provide you with any assistance you may require and carries genuine Gehl service parts. All parts should be obtained from or ordered through your Gehl dealer. Give complete information about the part and include the



### Typical Model & Serial Number Plate

model and serial numbers of your machine. Record the serial number in the space provided on the pictorial, as a handy record for quick reference.

The model number and serial number for the baler are on a decal located under the top channel, near the center column of the right frame assembly. "Right" and "left" are determined from a position standing at the rear of the unit facing the direction of travel. From this position, the baler drive sprocket on the transmission output shaft is on the left side.

Throughout this manual, information is provided that is set in *italic* type and introduced by the word **NOTE** or **IMPORTANT**. BE SURE to read carefully and comply with the message or directive given. Following this information will improve your operating and maintenance efficiency, help you avoid costly breakdowns and unnecessary damage, and extend your machine's life.

Gehl Company reserves the right to make changes or improvements in the design or construction of any part without incurring the obligation to install such changes on any unit previously delivered.

Standard hardware torques appear in a chart at the end of the manual.

**The Gehl Company, in cooperation with the American Society of Agricultural Engineers and the Society of Automotive Engineers, has adopted this SAFETY ALERT SYMBOL**



**to pinpoint characteristics which, if not properly followed, can create a safety hazard. When you see this symbol in this manual or on the unit itself, you are reminded to BE ALERT! Your personal safety is involved.**



## **Chapter 2 - Specifications**

### **Optional Features & Accessories (Customer Selected):**

540 or 1000 RPM Drives

Standard or Wide Width Pickups

Automatic Bale Control System

Automatic Twine Wrap System

Manual Twine Wrap System with  
Twine Arm Indicator

Steering Monitor for Bale Shape  
(Requires Automatic Bale Control System  
or Automatic Twine Wrap System)

Constant Velocity Drive Line with Shear Bolt  
Overload Protection and E-Z Spline Alignment

or

Constant Velocity Drive Line with Automatic  
Disconnect (540 only) or Slip Clutch (1000 PTO  
only) Overload Protection and E-Z Spline  
Alignment

Pickup Gauge Wheels (Standard on Wide Clean  
Sweep Pickups Only)

Bale Kicker (Cannot Be Used with Bale Ramps)

Bale Ramps with Adjustable Incline  
(Cannot Be Used with Bale Kicker)

Crowder Wheels

Automatic Chain Oiler

Hydraulic Pickup Lift

### **Service Accessories**

Safety Chain

Shear Bolts (8-pack)

Belt Dutchman

Belt Lacing Tool Kit

Belt Lacing and Pin Package

Electrical Harness and Connector Repair Kits

Twine Sensor Jumper Kit

Two Magnet Twine Wheels

# CHAPTER 3 CHECKLISTS

## PRE-DELIVERY

After the baler has been completely set up, the following inspections **MUST** be made before delivering it to the customer. Check off each item after prescribed action is taken.

**Check that:**

- NO parts of the unit have been damaged in shipment. Check for such things as dents and loose or missing parts; correct or replace components as required.
- All grease fittings have been properly lubricated and the gearbox is filled to the proper level; see Care & Maintenance chapter of this manual.
- All guards, shields and decals are in place and securely attached.
- All fasteners and wheel lug nuts are properly secured.
- All adjustments are made to comply with settings given in the Care & Maintenance chapter of this manual.
- Model and serial numbers for the baler are recorded in the spaces provided on this page and page 2.

**Hook the baler onto the appropriate RPM tractor and test run the unit while checking that proper operation is exhibited by all components.**

**Check that:**

- The telescoping PTO drive turns freely inside the drive shield tubes.
- Hydraulic hoses and all connections do not leak under pressure.
- Tailgate opens and closes without binding.
- Drives, rollers and belts are rotating smoothly and operating properly and belts are tracking properly.
- TDC reservoir pressure is at least 170 PSI (1034 kPa) and reservoir oil is at proper fill level.

I acknowledge that the pre-delivery procedures were performed on this unit as outlined.

---

Dealership's Name

---

Dealer Representative's Name

---

Date Checklist Filled Out

---

Baler Model Number	Serial Number
--------------------	---------------

## DELIVERY

The following checklist is an important reminder of valuable information that **MUST** be passed on to the customer at the time the unit is delivered. Check off each item as you explain it to the customer.

- Give the customer the Operator's Manual. Instruct customer and all operators to be sure to read and completely understand its contents **BEFORE** operating the unit.
- Direct the customer on how to use the Index of this manual as a quick page number locating guide.
- Explain and review with customer the **SAFETY** information in this manual.
- Explain and review with customer the Operation chapter of this manual.
- Explain that regular lubrication is required for continued proper operation and long life. Review the Lubrication section of the Care & Maintenance chapter of this manual.
- Explain and review with the customer the bale tying and/or wrapping system that the baler is equipped with.
- Explain the function and adjustment of the Total Density Control (TDC) system.
- Demonstrate the proper use of the spring-loaded PTO locking device, shuttle locks, rear gate cylinder locks, reversing wrench and hitchjack.
- Completely fill out the Owner's Registration, including customer's signature, and return it to the Gehl Company.

I acknowledge that the above points were reviewed with me at the time of delivery.

---

Customer's Signature

---

Date Delivered

**(Dealer's File Copy)**

**INTENTIONALLY BLANK**  
**(To be removed as Dealer's File Copy)**

# CHAPTER 3

## CHECKLISTS

### PRE-DELIVERY

After the baler has been completely set up, the following inspections **MUST** be made before delivering it to the customer. Check off each item after prescribed action is taken.

**Check that:**

- NO parts of the unit have been damaged in shipment. Check for such things as dents and loose or missing parts; correct or replace components as required.
- All grease fittings have been properly lubricated and the gearbox is filled to the proper level; see Care & Maintenance chapter of this manual.
- All guards, shields and decals are in place and securely attached.
- All fasteners and wheel lug nuts are properly secured.
- All adjustments are made to comply with settings given in the Care & Maintenance chapter of this manual.
- Model and serial numbers for the baler are recorded in the spaces provided on this page and page 2.

**Hook the baler onto the appropriate RPM tractor and test run the unit while checking that proper operation is exhibited by all components.**

**Check that:**

- The telescoping PTO Drive turns freely inside the drive shield tubes.
- Hydraulic hoses and all connections do not leak under pressure.
- Tailgate opens and closes without binding.
- Drives, rollers and belts are rotating smoothly and operating properly and belts are tracking properly.
- TDC reservoir pressure is at least 170 PSI (1034 kPa) and reservoir oil is at proper fill level.

I acknowledge that the pre-delivery procedures were performed on this unit as outlined.

---

Dealership's Name

---

Dealer Representative's Name

---

Date Checklist Filled Out

---

Baler Model Number	Serial Number
--------------------	---------------

### DELIVERY

The following checklist is an important reminder of valuable information that **MUST** be passed on to the customer at the time the unit is delivered. Check off each item as you explain it to the customer.

- Give the customer the Operator's Manual. Instruct customer and all operators to be sure to read and completely understand its contents **BEFORE** operating the unit.
- Direct the customer on how to use the Index of this manual as a quick page number locating guide.
- Explain and review with customer the **SAFETY** information in this manual.
- Explain and review with customer the Operation chapter of this manual.
- Explain that regular lubrication is required for continued proper operation and long life. Review the Lubrication section of the Care & Maintenance chapter of this manual.
- Explain and review with the customer the bale tying and/or wrapping system that the baler is equipped with.
- Explain the function and adjustment of the Total Density Control (TDC) system.
- Demonstrate the proper use of the spring-loaded PTO locking device, shuttle locks, rear gate cylinder locks, reversing wrench and hitchjack.
- Completely fill out the Owner's Registration, including customer's signature, and return it to the Gehl Company.

I acknowledge that the above points were reviewed with me at the time of delivery.

---

Customer's Signature

---

Date Delivered

**(Pages 5 & 6 Have Been Removed at Perforation)**



# CHAPTER 4 SAFETY



The above Safety Alert Symbol means **ATTENTION! BECOME ALERT! YOUR SAFETY IS INVOLVED!** It stresses an attitude of “Heads Up for Safety” and can be found throughout this Operator’s Manual and on the machine itself.

**BEFORE YOU OPERATE THIS EQUIPMENT, READ AND STUDY THE FOLLOWING SAFETY INFORMATION. IN ADDITION, BE SURE THAT EVERYONE WHO OPERATES OR WORKS WITH THIS EQUIPMENT, WHETHER FAMILY MEMBER OR EMPLOYEE, IS FAMILIAR WITH THESE SAFETY PRECAUTIONS.**

Our company **ALWAYS** takes the operator and his/her safety into consideration when designing its machinery, and guards exposed moving parts for his/her protection. However, some areas cannot be guarded or shielded in order to assure proper operation. Furthermore, this Operator’s Manual, and decals on the machine, warn of additional hazards, and should be read and observed closely.



## DANGER

“**DANGER**” indicates an imminently hazardous situation which, if not avoided, will result in death or serious injury.



## WARNING

“**WARNING**” indicates a potentially hazardous situation which, if not avoided, could result in death or serious injury.



## CAUTION

“**CAUTION**” indicates a potentially hazardous situation which, if not avoided, may result in minor or moderate injury. It may also alert against unsafe practices.

---

### MANDATORY SAFETY SHUTDOWN PROCEDURE

**BEFORE inspecting, unclogging, cleaning, adjusting, lubricating or servicing the unit:**

1. Disengage the tractor PTO.
2. Shut off the tractor engine, place the tractor transmission in park and/or lock brake pedals to prevent any tractor movement.
3. On auto-electric control equipped balers, **BEFORE** leaving the tractor seat to perform any function or maintenance, push “**POWER**” keypad to turn off power to the control.
4. Remove the starter switch key and take it with you when leaving the tractor seat.
5. Wait for all movement to stop.
6. Remove the telescoping drive and **ALL** power connections from the tractor.

**ONLY** when you have taken these precautions can you be sure it is safe to proceed. Failure to follow the above procedure could lead to death or serious bodily injury.

---

### ADDITIONAL SAFETY REMINDERS

Some photographs used in this manual may show doors, guards or shields open or removed for illustration purposes **ONLY!** **BE SURE** that all doors, guards and shields are in their proper positions and securely attached **BEFORE** operating this unit!

**BE SURE** to review and comply with **ALL** safety recommendations in the tractor operator’s manual.

**REMEMBER**, it is the owner’s responsibility to communicate information on the safe use and proper maintenance to users of this machine.

- **Preparing for Operation**

**BE SURE** that the telescoping PTO drive rotates freely inside the drive shield tubes at all times.



# SAFETY

(Continued)



- **Transporting Baler**

ALWAYS follow state and local regulations regarding use of a safety chain and transport lighting when towing farm equipment on public highways. A safety chain should always be used to retain the connection between the towing and towed machines, in the event of separation of the primary attaching system. BE SURE to check with local law enforcement agencies for your area's particular regulations. Unless otherwise prohibited, use a Slow-Moving Vehicle (SMV) emblem.

Limit towing speed to 20 mph (32 km/h).

Only a safety chain (NOT an elastic or nylon/plastic tow strap) should be used to retain the connection between the towing and towed machines, in the event of separation of the primary attaching system. Refer to the Optional Features & Accessories chapter for safety chain.

For implements without brakes, safety codes recommend that the total weight of the implement and load not exceed one-and-one half (1-1/2) times the weight of the towing vehicle. For any public highway travel, and to be in compliance with this rule, BE SURE that your tractor is heavy enough to counterbalance the weight of the baler and a full-sized bale.

Always use adequate lights or safety warnings when transporting the machine on public roads and after dark. Check with the local law enforcement agencies for specific requirements.

- **Maintenance/Service**

ALWAYS wear safety glasses with side shields when striking metal against metal! In addition, it is recommended that a softer (chip-resistant) material be used to cushion the blow. Failure to heed could result in serious injury to the eyes or other parts of the body!

NEVER use your hands to search for hydraulic fluid leaks; use a piece of cardboard. Escaping fluid under pressure can be invisible and penetrate the skin causing serious injury! If any fluid is injected into your skin, see a doctor at once! Injected fluid MUST BE surgically

removed by a doctor familiar with this type of injury or gangrene may result.

Tire mounting, service or inflation can be hazardous. Whenever possible, trained personnel should service and mount tires, following the tire manufacturer's instructions. If you do not have such instructions, contact your tire dealer or our Company. In any event, to avoid possible fatal or serious injury, follow the specific directives given in the Service section of the Care & Maintenance chapter.

To ensure continued safe operation, replace damaged or worn-out parts with genuine Gehl service parts, BEFORE attempting to operate this equipment.

- **Bale Handling**

Bales made with the round baler are LARGE, CYLINDRICAL and HEAVY. Serious personal injury or property damage could result if the bales are not carefully and properly handled. NEVER eject or store bales where they could possibly roll or shift from their stored position.

After completing a bale, but before opening the rear gate, check to be sure no one is near the rear of the baler. Bales are heavy and can roll, and can crush bystanders. Eject the bale on level ground, in a position such that it won't roll.

Tractors used for moving bales must be large enough and have sufficient counterweight to handle bales safely. Use of a tractor with a four-post ROPS is strongly recommended.

When using a front-end loader to transport bales, it should be equipped with an attachment specifically intended to handle large round bales, such as a grapple or a bale spear. Adjustable tractor wheels should be set at maximum width to increase stability.

Always carry bales low, and at slow speeds. Avoid slopes whenever possible. On sloped terrain, travel straight up and down the slope with the bale directed uphill. Do not travel across the slope while carrying the bale.



# SAFETY

(Continued)



- **Operation**

While mowing, raking, merging windrows and baling, watch for objects such as stones and tree branches. Remove any objects that might interfere with baler operation.

NEVER attempt to hand-feed or kick any crop or material into the baler!

NEVER attempt to hand-feed or remove twine from the baler while it is running.

Park the unit on firm, level ground. Before disconnecting the unit from the tractor, be sure the hitchjack locking pin is fully engaged, and that the unit is properly blocked to prevent it from rolling.

- **Fire Precautions**

Always have a large water-type (Class A) fire extinguisher readily available in case of a fire.

Check fire extinguisher regularly to be sure it is fully charged and in operating condition.

Do not allow crop material to accumulate around rollers or other moving parts.

Check for overheating around moving parts, such as bearings. Worn bearings must be replaced immediately.

Use a tractor with an upright exhaust system, NOT an under-slung exhaust system.

In case of fire:

1. IMMEDIATELY eject bale.
2. Move the baler up-wind 30 feet (9 m) or more away from the ejected bale and other combustible material.
3. Shut off the tractor engine and put out the fire with a fire extinguisher.



# SAFETY

(Continued)



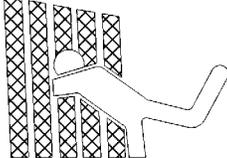

**DANGER**

**Stay clear! Contact with moving belts will cause injury.**

093461

**WARNING**

**TO AVOID INJURY OR DEATH:**

Follow **MANDATORY SAFETY SHUT-DOWN PROCEDURE** before working on or around machine.

1. Disengage tractor PTO, shut off engine;
2. Apply parking brake, relieve pressure/ lower equipment;
3. Remove key, wait for all movement to stop;
4. Disconnect PTO driveline and all power connections to implement.

163941

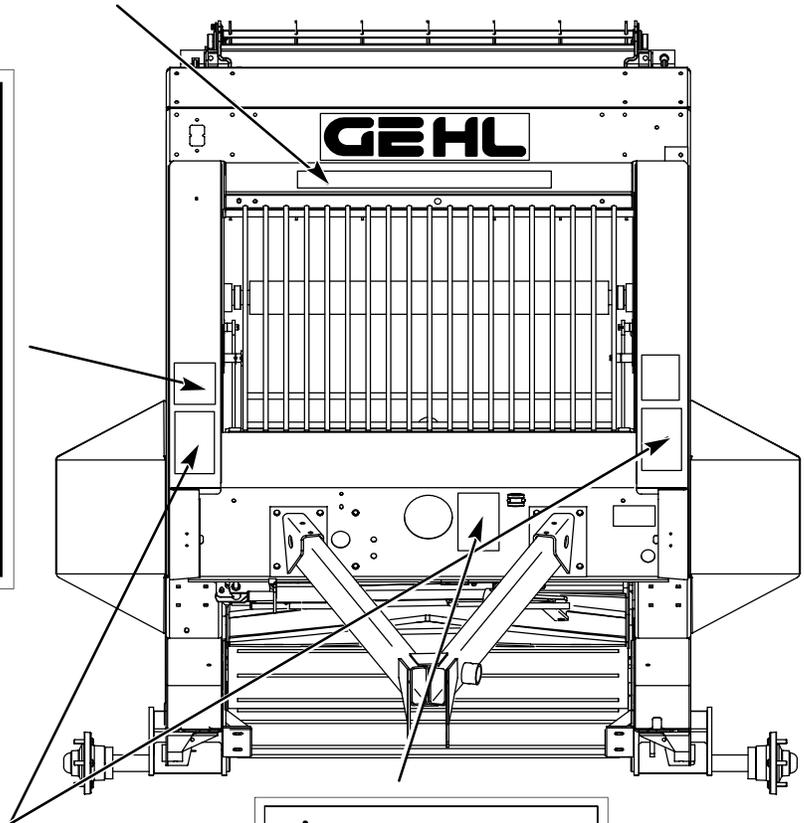

**DANGER**

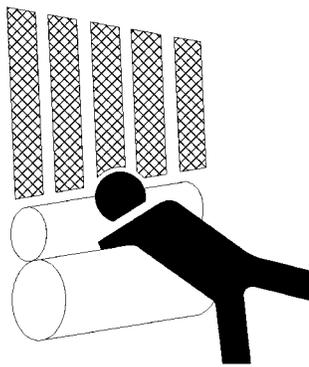

**ENTANGLEMENT HAZARD**

NEVER attempt to unplug or feed crop or twine into baler while it is running.

Material feeds into baler faster than you can react to release it.

093462

**WARNING**



**CRUSH HAZARD**

Keep people away from rear of baler.

DO NOT eject a bale where it might roll down hill.

Bales are heavy and round, and can cause injury or property damage if not handled properly.

163942



# SAFETY

(Continued)

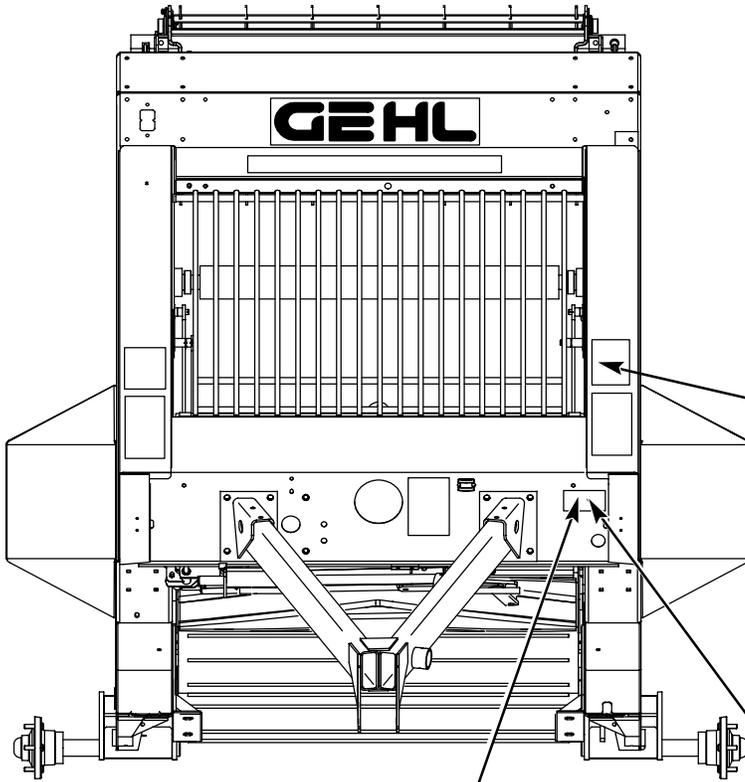

## **WARNING**

### TO AVOID INJURY OR DEATH:

- BEFORE inspecting, unplugging, lubricating or servicing machine, follow MANDATORY SAFETY SHUTDOWN PROCEDURE in Operator's Manual.
- Keep all guards and shields in place.
- BE SURE machine is clear of people, tools and other objects before starting.
- DO NOT wear loose clothing around this machine. Keep hands, feet, hair and clothing away from moving parts.
- Keep children and by-standers away from machine while it is operating.
- NEVER carry riders.
- On public roads, follow local laws regarding lighting, marking, slow-moving vehicle (SMV) emblem and safety chains.

093373

## **WARNING**



Operate only with  
540 RPM PTO.  
DO NOT operate with  
1000 RPM PTO.  
Overspeed can cause  
death, injury or damage.

093466

## **WARNING**



Operate only with  
1000 RPM PTO.  
DO NOT operate with  
540 RPM PTO.  
Misuse can cause death,  
injury or damage.

093465



# SAFETY

(Continued)



 <b>WARNING</b>		<p>Wrench may rotate or fly off and strike someone.          Disconnect PTO before using wrench.          Remove wrench before resuming operation.</p> <p style="text-align: right;"><small>093458</small></p>
--	---	--

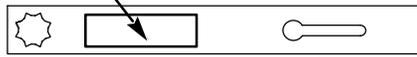

REVERSING HANDLE

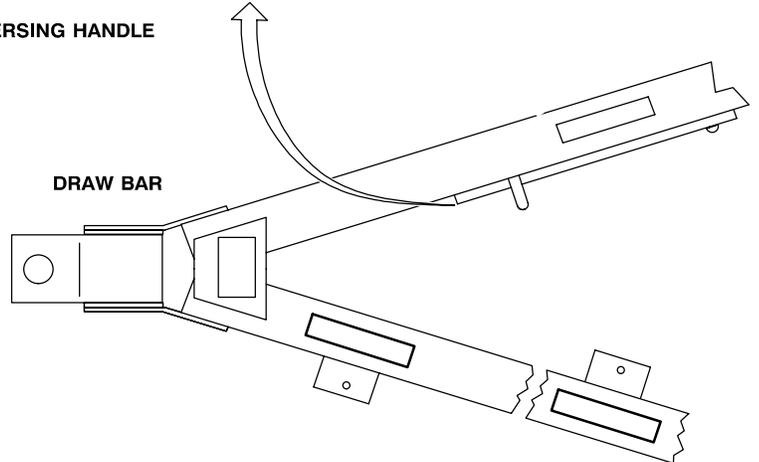

DRAW BAR

 <b>DANGER</b>

<p><b>ROTATING DRIVELINE</b>          CONTACT CAN CAUSE DEATH  <b>KEEP AWAY!</b></p> <p><b>DO NOT OPERATE WITHOUT-</b></p> <ul style="list-style-type: none"> <li>• ALL DRIVELINE, TRACTOR AND EQUIPMENT SHIELDS IN PLACE.</li> <li>• DRIVELINES SECURELY ATTACHED AT BOTH ENDS</li> <li>• DRIVELINE SHIELDS THAT TURN FREELY ON DRIVELINE</li> </ul> <p style="text-align: right;"><small>091444</small></p>

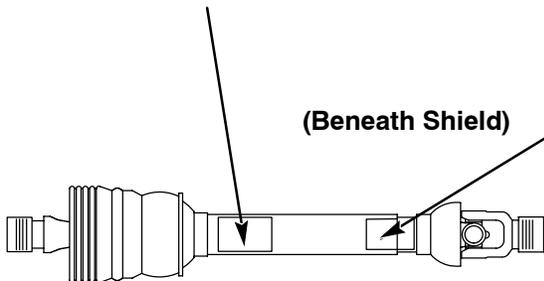

(Beneath Shield)

 <b>DANGER</b>

<p><b>SHIELD MISSING</b>  <b>DO NOT OPERATE</b></p>
 <b>DANGER</b>

<p><b>SHIELD MISSING</b>  <b>DO NOT OPERATE</b></p>
 <b>DANGER</b>

143007



# SAFETY

(Continued)



<b>! WARNING</b>	
 1000	Operate only with 1000 RPM PTO.
 540	DO NOT operate with 540 RPM PTO.
Misuse can cause death, injury or damage. <small>093465</small>	

<b>! WARNING</b>	
 540	Operate only with 540 RPM PTO.
 1000	DO NOT operate with 1000 RPM PTO.
Overspeed can cause death, injury or damage. <small>093466</small>	

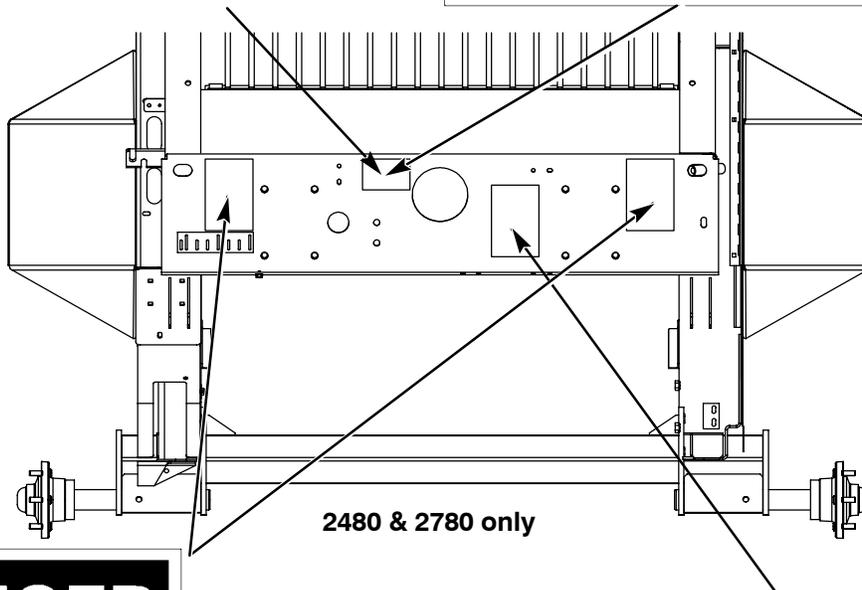

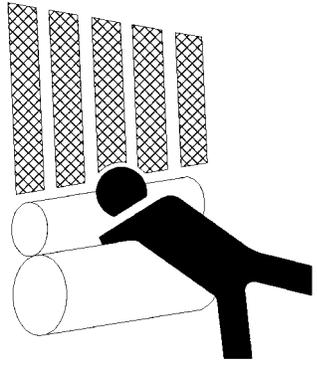
<b>! DANGER</b>

<b>ENTANGLEMENT HAZARD</b>
NEVER attempt to unplug or feed crop or twine into baler while it is running.
Material feeds into baler faster than you can react to release it. <small>093462</small>

<b>! WARNING</b>

<b>CRUSH HAZARD</b>
Keep people away from rear of baler.
DO NOT eject a bale where it might roll down hill.
Bales are heavy and round, and can cause injury or property damage if not handled properly. <small>163942</small>



# SAFETY

(Continued)



**! DANGER**



**STAY CLEAR** of tailgate when it is opening and closing.

Tailgate moves faster than you can move away.

Before working under open tailgate, lock tailgate lockout valve, shut off tractor and disconnect hydraulic lines.

119554

**! WARNING**



**EXPLOSION HAZARD**  
Charge only with dry nitrogen or compressed air.  
Use only an approved hydraulic fluid.  
Other gases and fluids may explode.

093459

**! WARNING**

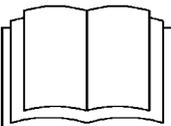

**TO AVOID INJURY OR DEATH:**

- Read Operator's Manual before using or servicing this machine.
- Owner is responsible to be sure that all users are instructed on safe use and maintenance.
- For information and service parts, contact your dealer or the manufacturer.

093367

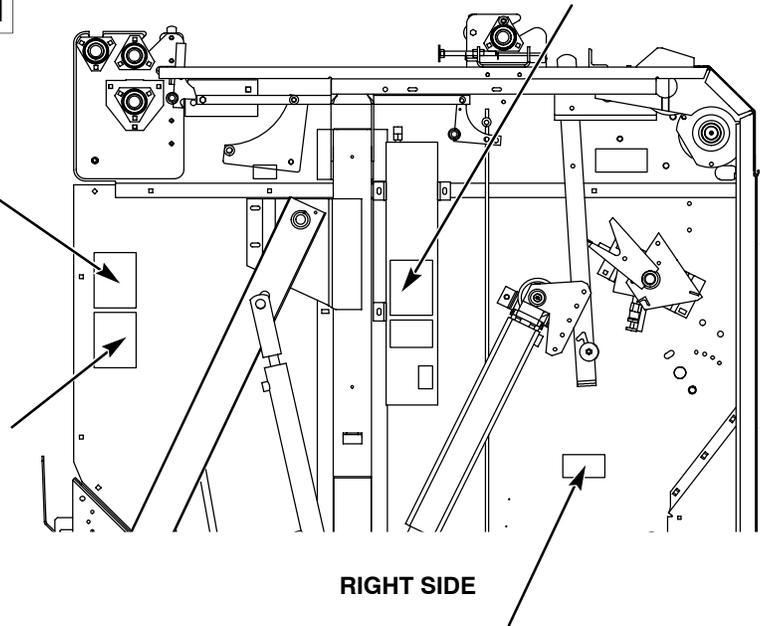

**! WARNING**



**Keep hands out!**



**Close doors and replace guards before operating.**

163957



# SAFETY

(Continued)



**! WARNING**



**ROTATING DRIVELINE**  
Keep people and clothing away.  
**DO NOT OPERATE WITHOUT:**

- PTO driveline shields
- Input shaft guards
- Tractor master shield
- U-joints locked to tractor and implement shafts

Driveline has a rotating shield which allows the internal drive shaft to rotate even when the shield is not rotating.

**DO NOT** remove shield. Be sure shield rotates freely, and any restraints are properly attached. 093653

**! DANGER**



**STAY CLEAR** of tailgate when it is opening and closing.

Tailgate moves faster than you can move away.

**Before working under open tailgate, lock tailgate lockout valve, shut off tractor and disconnect hydraulic lines.**

119554

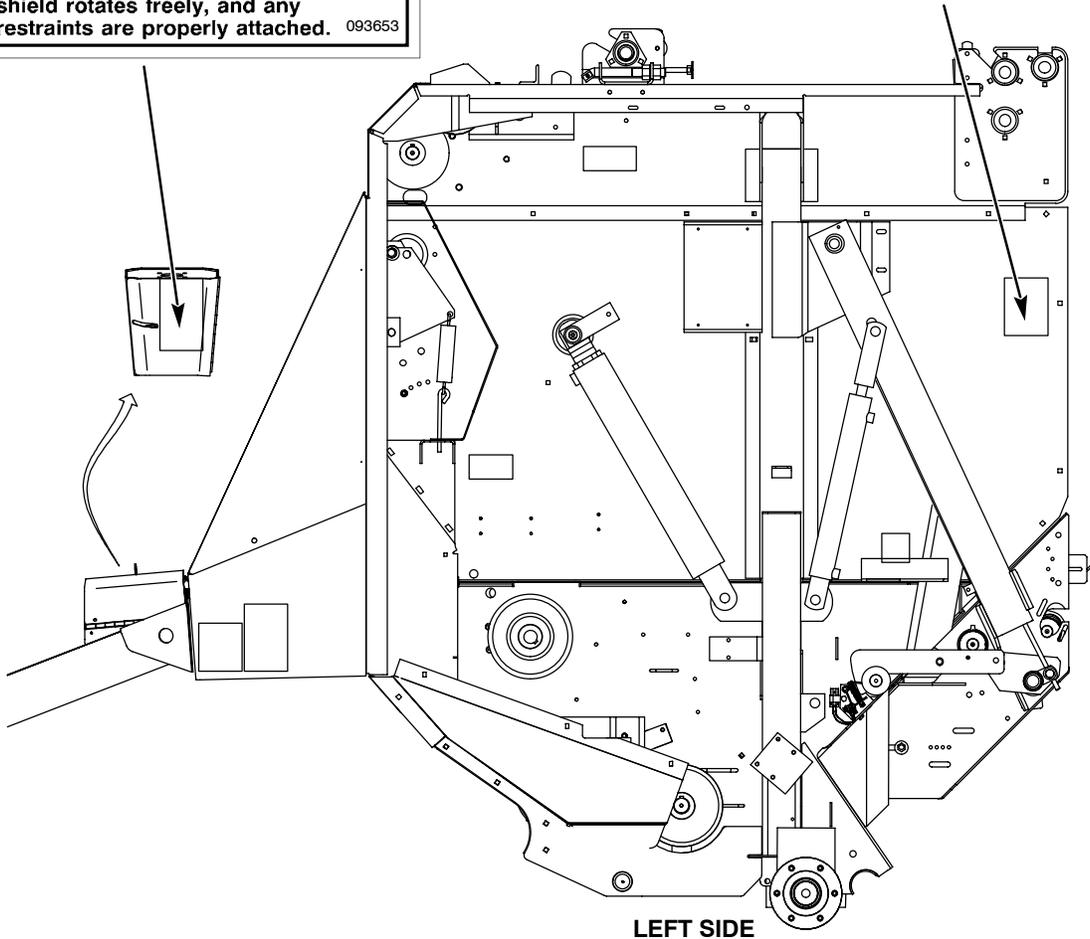



# SAFETY

(Continued)



**WARNING**

**TO AVOID INJURY OR DEATH:**

Follow **MANDATORY SAFETY SHUT-DOWN PROCEDURE** before working on or around machine.

1. Disengage tractor PTO, shut off engine;
2. Apply parking brake, relieve pressure/lower equipment;
3. Remove key, wait for all movement to stop;
4. Disconnect PTO driveline and all power connections to implement.

163941

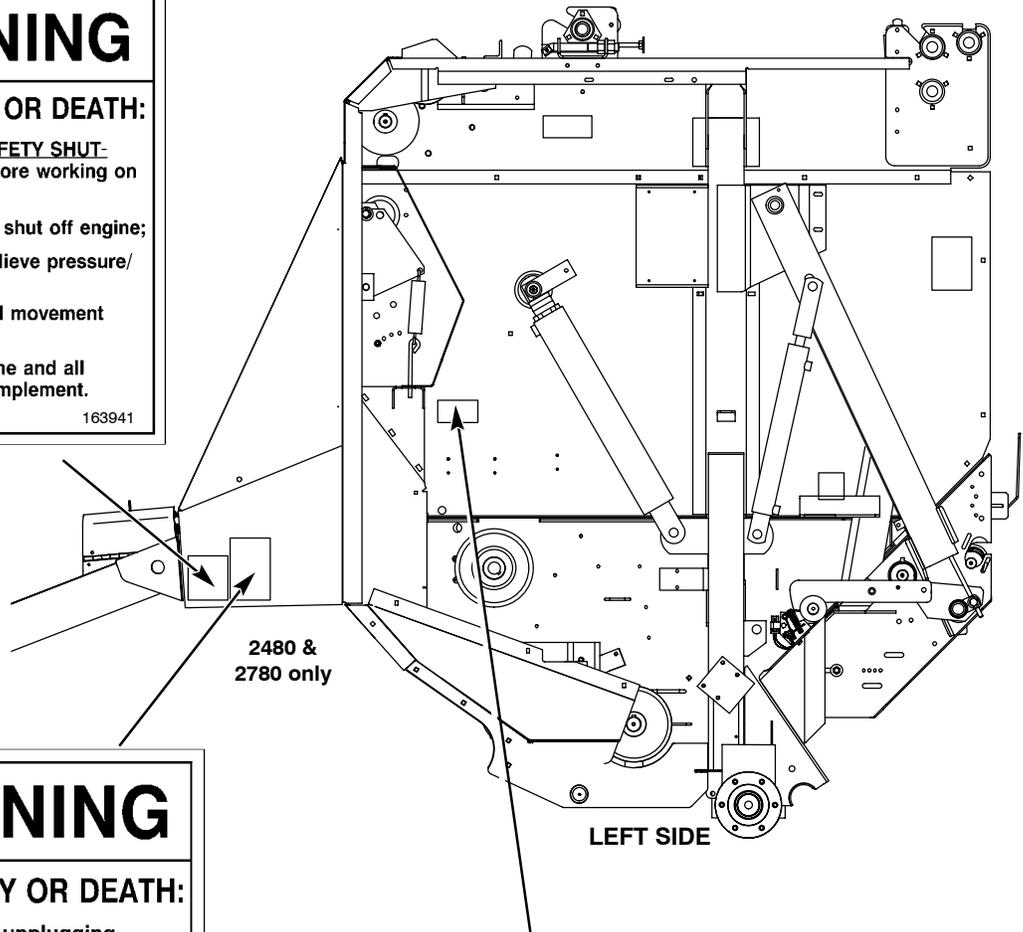

**WARNING**

**TO AVOID INJURY OR DEATH:**

- BEFORE inspecting, unplugging, lubricating or servicing machine, follow **MANDATORY SAFETY SHUTDOWN PROCEDURE** in Operator's Manual.
- Keep all guards and shields in place.
- BE SURE machine is clear of people, tools and other objects before starting.
- DO NOT wear loose clothing around this machine. Keep hands, feet, hair and clothing away from moving parts.
- Keep children and by-standers away from machine while it is operating.
- NEVER carry riders.
- On public roads, follow local laws regarding lighting, marking, slow-moving vehicle (SMV) emblem and safety chains.

093373

**WARNING**

**Keep hands out!**

**Close doors and replace guards before operating.**

163957



# SAFETY

(Continued)



	<b>WARNING</b>
	Keep hands out! Close doors and replace guards before operating.
<small>163957</small>	

All Balers  
(Shield Removed)

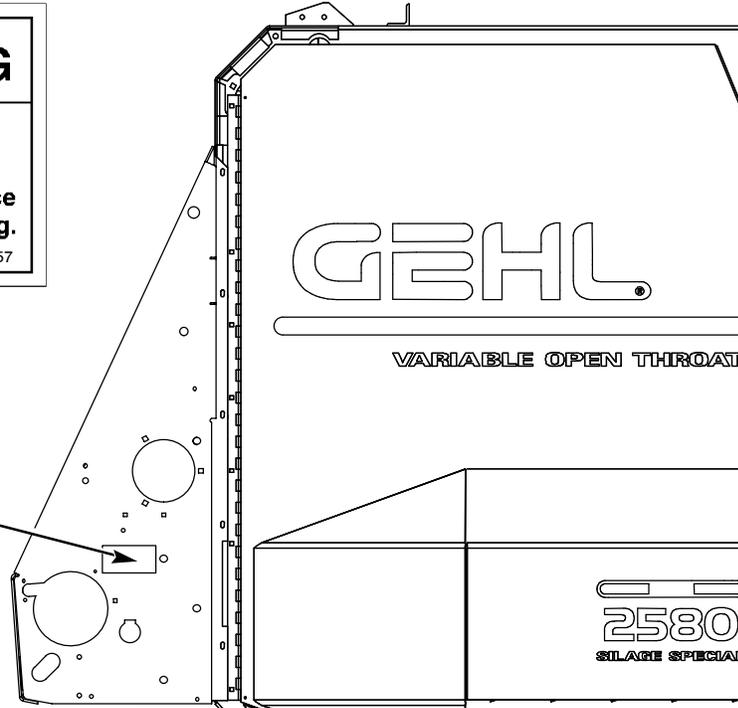

<b>DANGER</b>	
	Keep hands and feet out! Follow <b>MANDATORY SAFETY SHUTDOWN PROCEDURE</b> before unplugging or servicing.
<small>163962</small>	

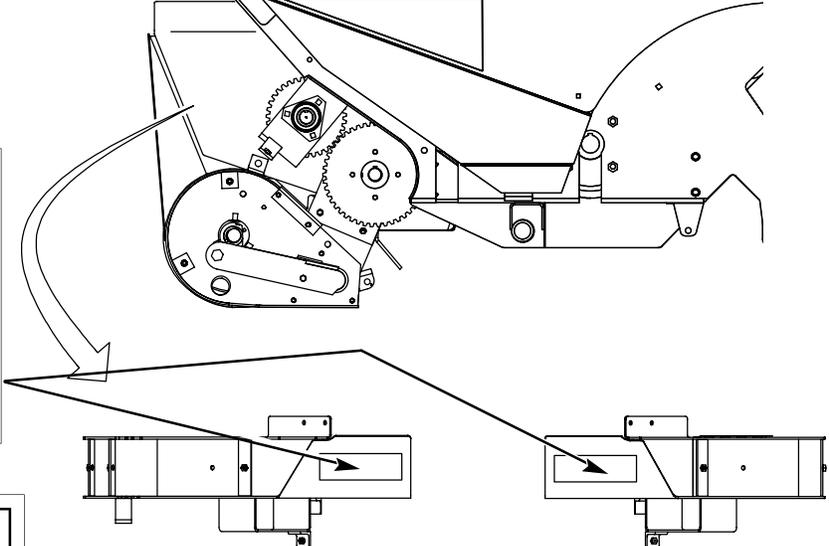

	<b>WARNING</b>
	Keep hands out! Close doors and replace guards before operating.
<small>163957</small>	

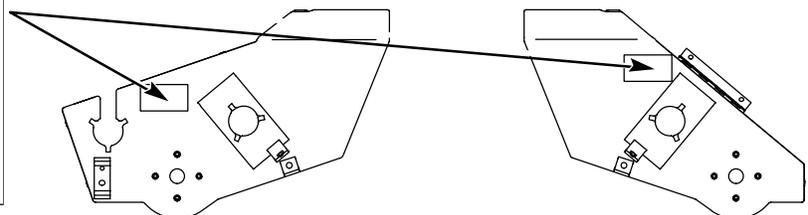

# Notes

# CHAPTER 5

## OPERATION

### HOW BALER FUNCTIONS

Crop material is picked off the ground by the pickup and delivered to the throat of the unit where it is pressed by the pivoting power in-feed roller against the fixed floor feed roller. The rollers then carry the crop to the back of the unit where the crop meets the belts which are traveling toward the front of the unit. The belts carry the crop forward and over the top of the lower incoming mat of material until it comes in contact with the bale starter fingers and stripper roll. The fingers deflect material down into the incoming mat of material to form a roll of crop material or bale core.

As the core of material grows in size, the bale starter fingers are repositioned to avoid contact with the bale. As the bale continues to grow, additional belting required to wrap the bale is released by the belt shuttle moving toward the rear of the baler. Belt tension and bale density are controlled by the Total Density Control (TDC<sup>®</sup>) system. The windrow size and driving pattern of the baler operator determine how well the material is distributed across the bale.

When the bale reaches the desired size, the twine or netting can be wrapped around the bale. Once wrapped, the bale is ejected by opening the tailgate, and the process of forming another bale can be repeated.

### SAFETY EQUIPMENT

Each model variable-chamber round baler is provided with similar features for operator safety.



## CAUTION

Become familiar with and know how to use **ALL** safety devices and controls on this machine **BEFORE** attempting to operate the unit. Know how to **STOP** machine operation **BEFORE** starting it.

### Guards, Doors & Shields

Whenever possible and without affecting machine operation, guards, shields and/or hinged covers have been used on this equipment to protect potentially hazardous areas. In many places, decals are also provided to warn of potential hazards and to display special operating procedures.



## WARNING

Read and observe **ALL** warnings on the unit **BEFORE** operating it. **DO NOT** operate this equipment unless **ALL** factory-installed guards and shields are properly secured in place. **BEFORE** working on the baler, and **BEFORE** removing or opening any shields, **BE SURE** to exercise the **MANDATORY SAFETY SHUTDOWN PROCEDURE** (page 8). Also, **BE SURE** to reinstall and close **ALL** shields **BEFORE** operating the baler.

### Hinged Guard Doors (Fig. 1)

Hinged doors are provided on both sides of the baler to cover and protect drives and the adjustable features of the TDC system. The doors should be closed and latched whenever the baler is running.



- 1 - Large hinged guard doors (both sides)
- 2 - Front hinged guard doors (both sides)  
(Not on 2480 and 2780)

Fig. 1

## Pickup Drive Guard (Fig. 2)

The pinch point of the pickup drive is shielded with a guard. **BE SURE** that the guard is always securely fastened in place while operating the baler.

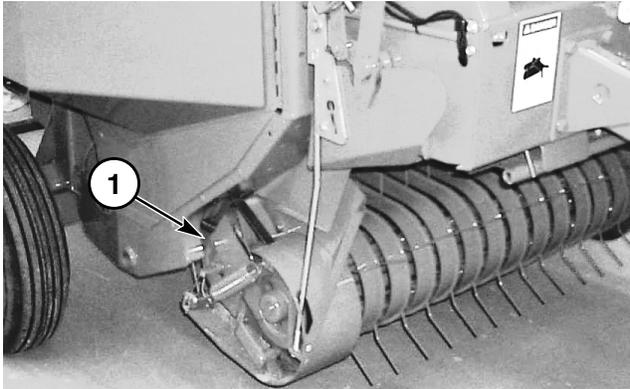

1 - Pickup drive guard

**Fig. 2: 2480 & 2780 only**

## Telescoping PTO Drive (Figs. 3 & 10)

The telescoping PTO drive, between the implement and tractor PTO shaft, is equipped with rotating shields.

# **WARNING**

**BE SURE** that the telescoping drive rotates freely inside the drive shield tubes at all times. **BE SURE** the telescoping drive connections are properly secured to the tractor PTO shaft and baler drive input shaft **BEFORE** starting the tractor engine. Also, **BE SURE** the tractor master shield is in place and properly secured **BEFORE** starting the tractor.

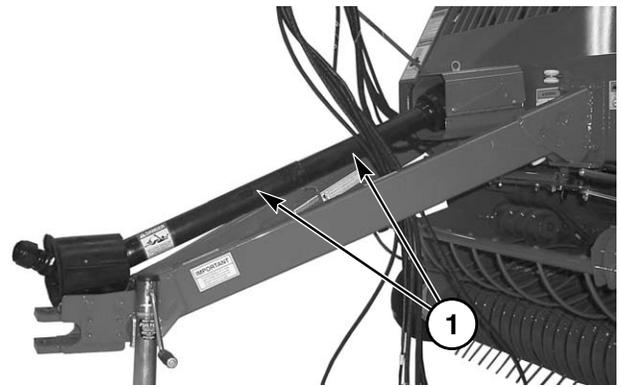

1 - Telescoping PTO drive with drive shield tubes

**Fig. 3**

## Front Guard Assembly (Figs. 4 & 5)

The front guard assembly serves as a barrier and a reminder to **KEEP AWAY** from the front of the baler while it is running. Furthermore, **DO NOT** place an arm or leg between the front guard bars while the baler is operating.

On 2480 and 2780 models, the front guard assembly can be unbolted at the bottom crossbar and pivoted up and out of the way when necessary. On 2580, 2680 and 2880 models, the front guard is held in place by the closed front guard doors and supported by a gas strut when raised.

In all cases, **BE SURE** the front guard is restored to its original position and secured **BEFORE** resuming operation.



1 - Front guard used on 2480 and 2780

**Fig. 4**

# WARNING

NEVER remove the front guard assembly from the baler. NEVER stand on or place your arms or legs through the front guard bars while the baler is running or moving. ALWAYS exercise the MANDATORY SAFETY SHUTDOWN PROCEDURE (page 8), BEFORE approaching the front guard assembly.

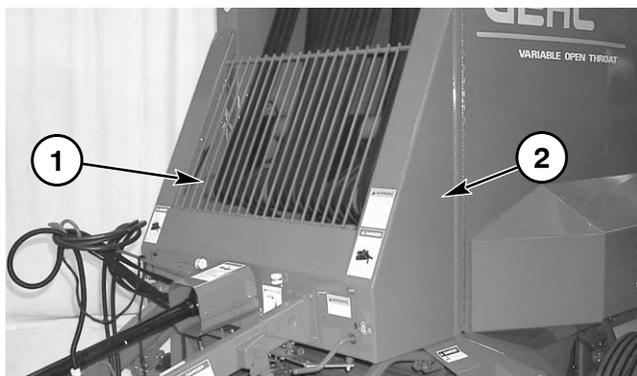

- 1 - Front guard assembly used on 2580, 2680 and 2880
- 2 - Hinged front guard door (both sides)

**Fig. 5**

## Tailgate Cylinder Lockout Valve (Figs. 6 & 7)

# WARNING

ALWAYS place tailgate cylinder lockout valve in locked position BEFORE working inside bale chamber or under open tailgate.

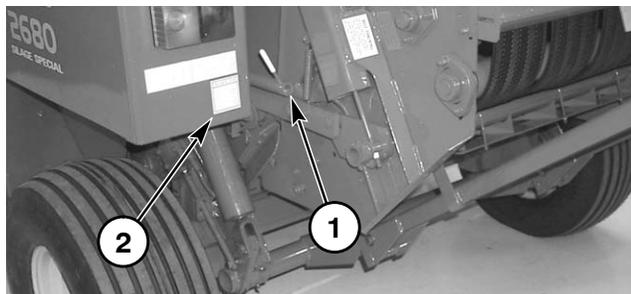

- 1 - Tailgate cylinder lockout valve in "open" position
- 2 - Tailgate lock decal

**Fig. 6**

The baler is equipped with a tailgate cylinder lockout valve that is used to lock and hold both tailgate lift cylinders inoperable in any position. The lift cylinders are free to operate when the valve handle is in the raised position (Fig. 6). The lift cylinders are locked in position when the tailgate cylinder lockout valve handle is in the lowered position (Fig. 7). On balers equipped with the bale kicker option, the lockout valve will prevent the kicker from being raised, but will permit the kicker to float to a lowered position.

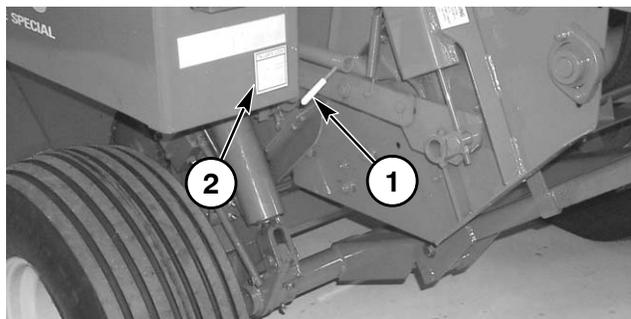

- 1 - Tailgate cylinder lockout valve in "locked" position
- 2 - Tailgate lock decal

**Fig. 7**

## Reversing Wrench (Figs. 8 & 9)

The round baler is provided with a reversing wrench for manually rotating the transmission output shaft. When not in use, the reversing wrench should be stored on the inside of the right hitch arm (Fig. 9).

### **WARNING**

**ALWAYS** exercise the **MANDATORY SAFETY SHUTDOWN PROCEDURE** (page 8) **BEFORE** using the reversing wrench. Also, **BE SURE** to return the wrench to its storage location **BEFORE** resuming baler operation.

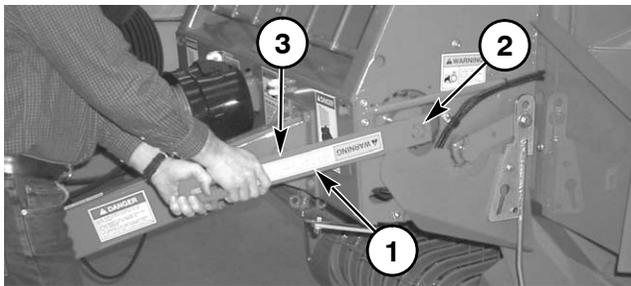

- 1 - Reversing wrench being used to reverse drive
- 2 - Transmission output shaft
- 3 - Direction of wrench rotation to reverse baler

Fig. 8



- 1 - Reversing wrench in "storage" location on inner right side of hitch

Fig. 9

## Fire Extinguisher (Customer Supplied)

### **WARNING**

In case of fire, eject bale **IMMEDIATELY**, move baler up-wind 30 feet (9 m) or more from ejected bale, shut off tractor and put out fire with fire extinguisher.

There is always the possibility of fire when handling dry forage materials. Gehl Company recommends that to limit the damage to the baler and/or tractor in case of a bale fire, a 2-1/2 gallon (10L) or larger, pressurized water-type (class A) fire extinguisher should be mounted on the tractor or baler, as a minimum protection.

**IMPORTANT:** A 2-1/2 (10L) extinguisher should be sufficient to put out any small fires that may be burning dry material that remains in the baler after the bale is ejected. However, this size extinguisher is **NOT** sufficient to put out even a small fire in the bale.

### **WARNING**

Because dry flammable material is being processed, the tractor should be equipped with a spark arrestor muffler, if the tractor emits sparks.

### **WARNING**

A pressurized water fire extinguisher **DOES NOT** replace the dry chemical fire extinguisher on the tractor (if so equipped). **NEVER** use a water-type fire extinguisher on electrical or fuel fires. Furthermore, to reduce the possibility of a fire, keep crop build-up to a minimum, especially on the roller ends, the chain drives (behind the hinged shields) and in the pickup drive area.

## Locking Hitch Pin(Fig. 10)

Each baler is equipped with a locking hitch pin as standard equipment for use during operation or transporting of the baler. Always engage the locking plate to prevent pin loss.

## Safety Chain & Transport Lighting (Figs. 10 & 11)



# WARNING

**ALWAYS** follow state and local regulations regarding a safety chain and transport lighting when towing farm equipment on a public highway. **BE SURE** to check with local law enforcement agencies for your own particular regulations. Unless otherwise prohibited, use a **Slow-Moving Vehicle (SMV) emblem**. Only a safety chain (NOT an elastic or nylon/plastic tow strap) should be used to retain the connection between the towing and towed machine, in the event of separation of the primary attaching system.

As required or when desired, the baler should be equipped with the optional safety chain for transporting the unit on public highways. The chain should be routed as shown in Fig. 10. Balers are equipped with transport lights as standard equipment. The light harness uses an SAE standard J560 7-pin connector. See your tractor dealer if your tractor is not equipped with the mating connector.

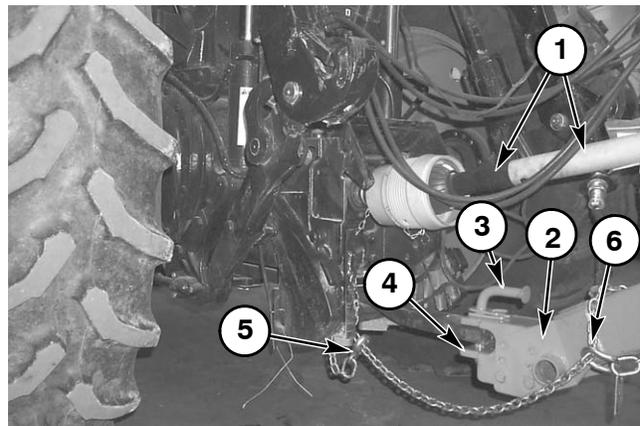

- 1 - Telescoping PTO drive with drive shield tubes
- 2 - Driveline stand in "storage" position (if so equipped)
- 3 - Locking hitch pin
- 4 - Drawbar clevis (provided)
- 5 - Chain secured around tractor frame member
- 6 - Safety chain attached around baler frame

Fig. 10: Optional Safety Chain

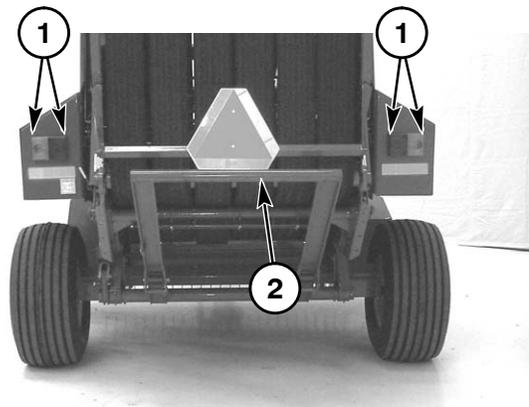

- 1 - Transport lighting
- 2 - Slow-Moving Vehicle (SMV) emblem

Fig. 11

## PREPARING BALER FOR FIELD OPERATION

### Tractor Requirements & Hitch Connections (Figs. 12, 13 & 14)

The round baler MUST be operated by a tractor with:

1. For operation on level ground, a minimum PTO power output of 50 hp (37 kW) (2480, 2780), 60 hp (45 kW) (2580, 2680), or 70 hp (52 kW) (2880) is needed. Silage Special balers and operation on hilly terrain will require a higher horsepower tractor.

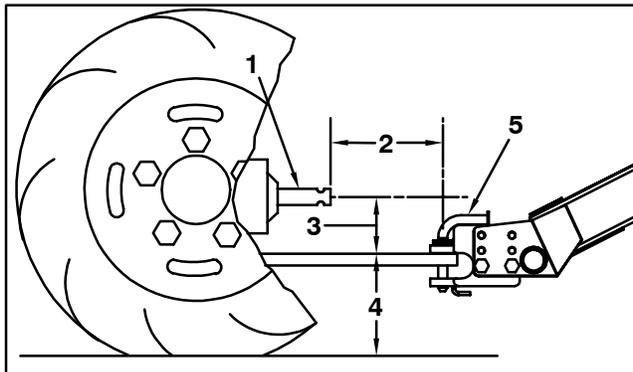

- 1 - Tractor PTO shaft\*
- 2 - 14" (356 mm) for 540 RPM operation (16", 400 mm for 1000 RPM) (measured from end of PTO shaft to center of hitch pin)
- 3 - 6-12" (152-305 mm)\*
- 4 - 13-17" (330-432 mm) from ground
- 5 - Locking hitch pin (provided)

\*Tractor MUST comply with ASAE standard S203

**Fig. 12: Drawbar Hitch Plate in "Low" Mounting Position (For Tractors with 13-17" (330-432 mm) Drawbar Ground Clearance**

2. A minimum wheel inside dimension of 45" (1143 mm) for 4' wide balers and 61" (1549 mm) for 5' wide balers is recommended.
3. A PTO that matches the RPM requirements of the baler.

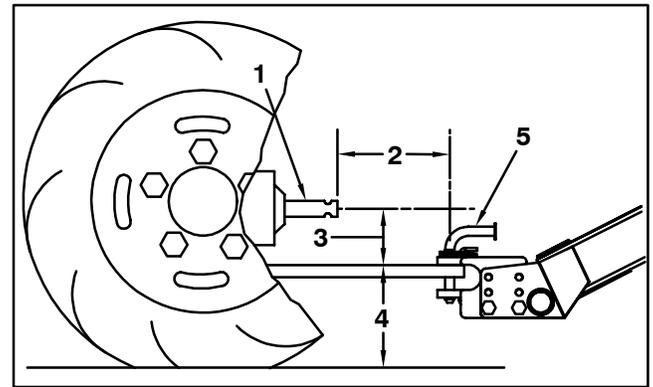

- 1 - Tractor PTO shaft\*
- 2 - 14" (356 mm) for 540 RPM operation (16", 400 mm for 1000 RPM) (measured from end of PTO shaft to center of hitch pin)
- 3 - 6-12" (152-305 mm)\*
- 4 - 17-21" (432-533 mm) from ground
- 5 - Locking hitch pin (provided)

\*Tractor MUST comply with ASAE standard S203

**Fig. 13: Drawbar Hitch Plate in "High" Mounting Position (Tractors with Greater than 17" (432 mm) Drawbar Ground Clearance**

4. At least one set of double-acting hydraulic outputs with greater than 12 gpm (45 L/min) and 2000 PSI (138 Bar) to operate tailgate cylinders.
5. Standard PTO and hitch dimensions conforming to ASAE standard S203, as shown in Figs. 12 and 13.

Figure 12 shows one of the two possible mounting positions for tractors with drawbars having 13-17" (330-432 mm) ground clearance. Figure 13 shows one of the two possible mounting positions for tractors with drawbars having a ground clearance greater than 17" (432 mm).

### Drawbar Connection

When hooking the baler to the tractor drawbar, BE SURE to use the locking hitch pin provided. The proper baler-tractor hook-up will allow maximum ground clearance and ensure that the baler will remain attached to the tractor.

## WARNING

**NEVER** connect a 1000 RPM tractor to a baler equipped for a 540 RPM PTO drive.

## WARNING

**Because dry flammable material is being processed, the tractor should be equipped with a spark arrestor muffler, if the tractor emits sparks.**

**IMPORTANT:** *If this unit is connected to a tractor equipped with a clevis-style drawbar, the clevis parts shown in dashed lines **MUST** be removed to prevent damage to the unit driveline. See Fig. 14.*

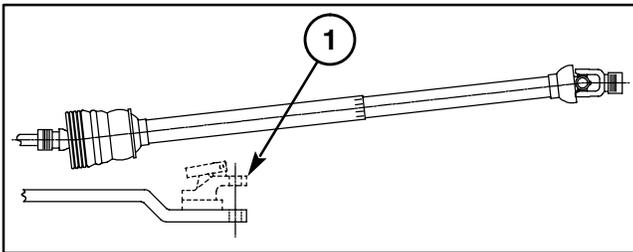

1 - Hammer strap hitch parts to be removed

Fig. 14

## Drawbar Flap (Fig. 15)

If the baler drawbar is catching and bunching up the windrow below the hitch, fabricate and install a drawbar flap from used baler belting or other pliable product to help eliminate the problem.

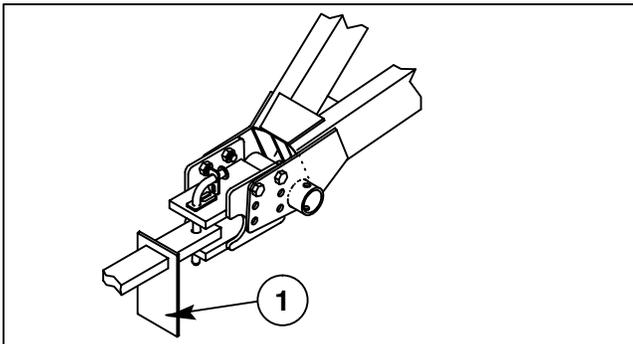

1 - Drawbar flap

Fig. 15

## PTO Drivelines (Figs. 12-17)

There are two styles of drivelines used on the 80 Series balers, the standard-duty driveline and the heavy-duty driveline. Both drivelines contain a telescoping spline shaft, 60° of free rotation for easy spline alignment, and an 80° constant velocity joint. Both are fastened to the implement with 1/2" bolts.

**IMPORTANT:** *Whether in operation or not, the maximum joint angle **MUST NOT** exceed 80°. Any angle greater than 80° **WILL** result in damage to the joint. In addition, for continuous operation, the maximum joint angle should be limited to 35°. Wide-angle constant velocity joints are **NOT** designed for use as angled gearboxes. Any continuous operation at angles greater than 35° **WILL** result in shortening joint life.*

The standard-duty driveline is provided on all balers except the 2880, the Silage Special models, and any baler equipped with a 1000 RPM drive. ALL balers can be upgraded to a heavy-duty driveline. The standard driveline is a Category 3 driveline with shear bolt overload protection. The replacement shear bolt should be a 1/4 x 1-1/2" Grade L9 bolt (order 095141 for a package of 8). The shear bolt should be assembled from the implement end toward the tractor to ensure the correct shear value by shearing through the shank of the bolt and not the threads.

The heavy-duty driveline is installed as standard equipment on the 2880, all Silage Special models, and all 1000 RPM drive balers. The heavy-duty driveline can also be installed on any baler as an option. On 1000 RPM balers, the heavy-duty driveline is a Category 4 driveline with a slip clutch for overload protection. The slip clutch is a non-adjustable device that is designed to withstand high intermittent load spikes without interrupting normal baler operation. If the slip clutch should experience continual high load, the clutch will slip and only transmit 50 to 60 percent of its rated or break-away torque. Once the clutch slips to the point where the baler drives have stopped and the driveline is still turning, the tractor PTO should be stopped. Exercise the Mandatory Safety Shutdown Procedure (page 8). Look for and eliminate the cause of clutch slippage. The clutch will not regain full torque capability until the clutch has cooled down. Running under light loads will help cool the clutch. Excessive slipping will cause severe wear to the friction discs and reduce the clutch's torque transmitting ability. Refer to the Service section of the Care & Maintenance chapter for replacing the the clutch friction discs. Refer to the Overload Protection section in the Operation chapter for clutch type identification.

On 540 RPM balers, the heavy-duty driveline automatically disconnects power when a torque spike exceeds

the clutch limit. Exercise the Mandatory Safety Shutdown Procedure (page 8). Look for and eliminate the cause of clutch slippage. The clutch will automatically re-engage when the cause for the overload is eliminated and the drive is re-started.

When connecting a standard-duty PTO to the tractor, depress and hold the locking device against the spring tension, and slide the yoke onto the tractor PTO drive shaft. Release the locking device and move the yoke ahead or back until the lock engages into the groove of the tractor PTO shaft. On a heavy-duty PTO, the locking ring locks back until the lock engages the groove of the tractor PTO shaft, then self-releases and locks the PTO in place. BE SURE the driveline is secured to the tractor PTO shaft.

## WARNING

**BE SURE** that the telescoping drive rotates freely inside the drive shield tubes at all times. **BE SURE** the telescoping drive connections are properly secured to the tractor PTO shaft and baler drive input shaft **BEFORE** starting the tractor engine. Also, **BE SURE** the tractor master shield is in place and properly secured **BEFORE** starting the tractor.

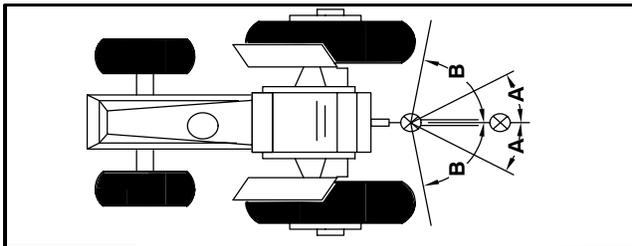

A - 35° (Maximum) in continuous operation  
B - 80° (Maximum) at any time

**Fig. 16: PTO Constant Velocity Driveline Joint**

**NOTE:** On 2580, 2680 and 2880 balers, when the baler is disconnected from the tractor, the PTO can be placed onto the driveline storage stand, mounted on the right side of the hitch clevis assembly. The driveline storage stand is designed to be pivoted out of the way when not in use.

**IMPORTANT:** When transporting the baler, leave the telescoping PTO drive attached to the tractor. If the PTO is NOT connected, it should be completely disconnected from the baler and stored in or on the towing vehicle to avoid separation and driveline damage.

## Hydraulic Connections (Fig. 17)

The hoses for the hydraulic tailgate cylinders are equipped with Pioneer ASAE S366.1 (SAE J1036, ISO 5675) quick-disconnect couplers. The baler is delivered already filled with hydraulic fluid in the tailgate hydraulic system (and bale kicker hydraulic system, if so equipped). For proper baler performance, the tractor should be able to supply a minimum of 12 gpm (45 L/min) and 2000 PSI (138 Bar) of pressure. Tractor hydraulic pressure should not exceed 3000 PSI (207 Bar). On tractors capable of high hydraulic flow rates, the flow should be reduced to 15-20 gpm (57-76 L/min).

**IMPORTANT:** BE SURE the fluid in the baler is compatible with your tractor's hydraulic system **BEFORE** connecting to the tractor. If fluid is NOT compatible, the system will have to be drained and refilled with the fluid used in your tractor.

**IMPORTANT:** Whenever service is performed on hydraulic components (valves, cylinders, hoses, etc.), **care must be taken to prevent discharging fluid onto the ground.** Catch and dispose of fluid per local waste disposal regulations.

BE CAREFUL when handling hoses and fittings to ensure they are kept free of dirt and contamination to avoid damage to baler and/or tractor hydraulic systems.

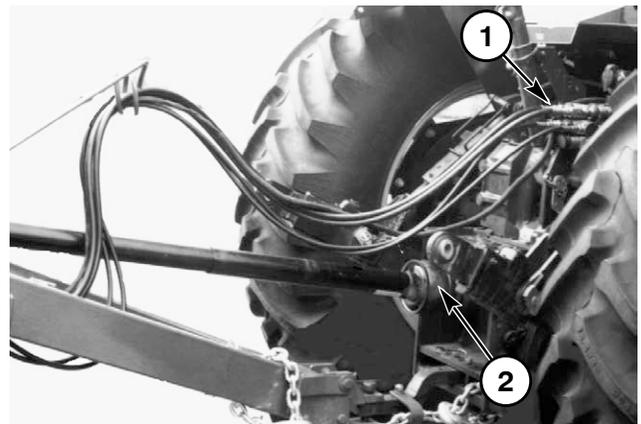

1 - Hydraulic disconnects  
2 - CV joint connected to tractor PTO shaft

**Fig. 17**

## Transport Lighting

The transport lighting is properly connected to a tractor equipped with a SAE J560 7-pin connector when:

1. Both red lights illuminate at lower intensity when front road lights are on and both amber lights blink slowly when transport lights are activated.
2. Right amber and red lights blink quickly, left amber light burns steady and left red light increases in brightness when right turn signal is activated.
3. Left amber and red lights blink quickly, right amber light burns steady and right red light increases in brightness when left turn signal is activated.

See your tractor dealer if your tractor is not equipped with the proper connector.

## Twinebox Assemblies (Figs. 18 & 19)



**NEVER** climb onto or ride on baler while it is moving or being operated.

The twinebox assembly provides protection from the tires, a place to store twine and a place to store the Operator's Manual on the left side. The right twinebox provides a place to store shear bolts for balers equipped with a chain-driven pickup.

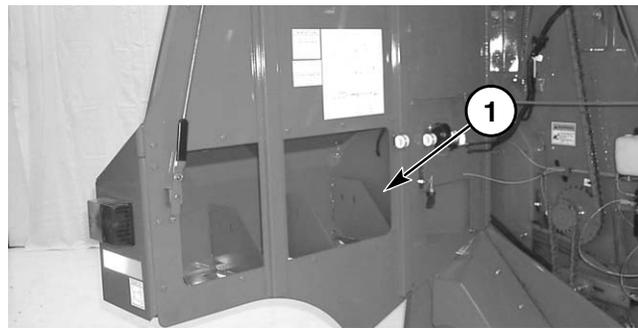

1 - Operator's Manual location inside twinebox

**Fig. 18: Inside of Twinebox on Left Side**

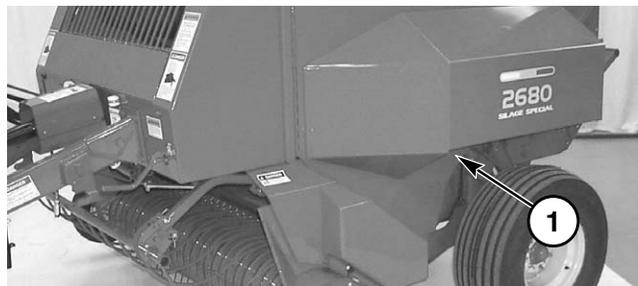

1 - Twinebox on left door

**Fig. 19**

## Twine & Twine Routing (Figs. 20 thru 24)

The baler is designed to use either sisal or plastic twine. The recommended twine to use is the 16,000-20,000 feet per ball (4877-6096 m) of either material. Heavier twine such as 9,000-10,000 feet per ball (2743-3048 m) can also be used. However, if the heavier twine is used, the twine jaw spring tension may need to be adjusted. See the Twine Jaw topic of the Adjustment section in the Care & Maintenance chapter. To thread the baler with twine, proceed as follows:

**NOTE:** Use the following twine routing procedure from each twinebox to route the twine from the twine boxes to the twine arms.

1. Place up to three balls of twine in each twinebox. If continuous feeding is desired, route the twine end through the guide above the twine ball in the twinebox, tie the twine ends together (always tie the outside twine end of the first ball to the inside twine end of the next ball for continuous feeding). On each side of the baler, pull the end of twine from the center of the first ball and out through the twine guide on the side of the door.

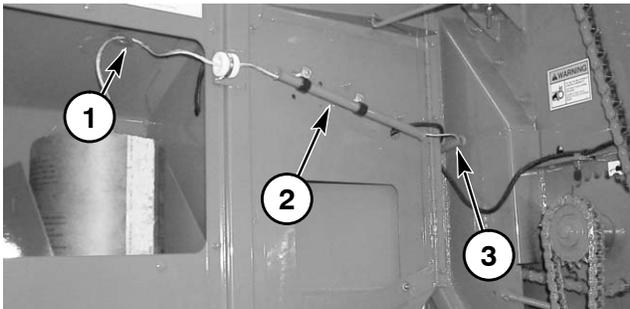

- 1 - Twine routed through guide in cover
- 2 - Twine routed through twine tube in door
- 3 - Twine routed to and through twine tube in front frame

**Fig. 20: Manual and Auto Twine Wrap Models**

2. On manual or auto twine control models, feed the twine through the twine tube on the door and through the twine tube to the front hitch. See Fig. 20.

On auto bale control models, feed the twine through the twine sensor on the door and through the twine tube to the front hitch. See Fig. 21.

**NOTE:** The characteristics of the wrapping materials used to wrap bales vary significantly. Therefore, the way in which the twine is routed around the twine wheels is important. To achieve optimum placement of the wrapping material on the bale, the plastic material should be wrapped around the twine wheels 1-1/2 times. The sisal style twine works best with a 1/2 wrap around the twine wheel. However, if the twine wheel appears to be slipping, 1-1/2 wraps around the twine wheel should be considered.

**NOTE:** The twine keeper is adjusted so it is centered over wheel and is seated against bottom or "root" of groove of the wheel without contacting twine guides. It is important that the twine keeper be centered between the flanges of the twine wheel to prevent drag on the twine wheel.

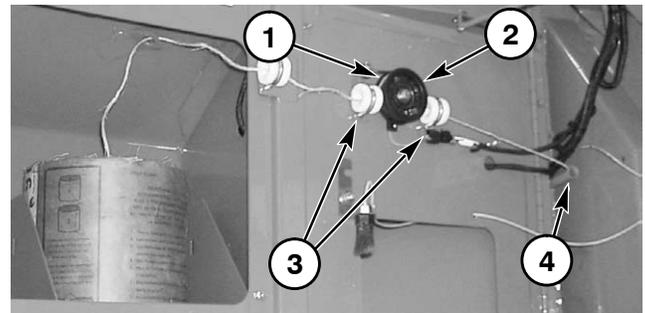

- 1 - Twine keeper resting on guide inside cover
- 2 - Twine wheel
- 3 - Twine guide
- 4 - Twine routed to and through twine tube in front frame

**Fig. 21: Twine Sensor  
(Automatic Bale Control Model)**

3. On 2480, 2580 and 2680 model balers, continue routing the twine through the three rope guides on the front of the baler as shown and into one of the two tubes on the twine arm. See Fig. 22.

On 2780 and 2880 model balers, continue routing the twine through the two upper rope guides on the front of the hitch and into the one rope guide on the lower front of the hitch underneath the PTO. Continue into one of the two tubes on the twine arm. See Fig. 23.

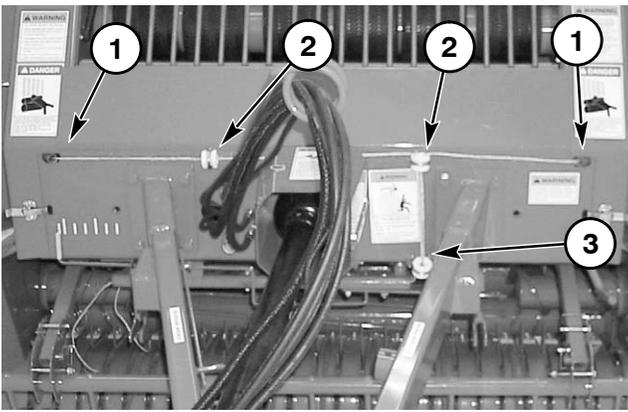

- 1 - Twine exiting twine tubes in front frame
- 2 - Twine routed into guides on hitch assembly (both twines)
- 3 - Twine routed into rope guide to twine arm (both twines)

**Fig. 22: Front Twine Routing on 2480, 2580 and 2680 Balers**

- 4. On all model balers, route the twine through the twine arm as shown in Figure 24, being sure to route the twine under the twine tension plate and between the two spring-loaded bolts. Twine tension is controlled on the twine arm by increasing spring tension on the plate. After the twine is through the twine arm, pull some twine from the twine arm to make sure it is dispensing freely and NOT hanging up. Cut off any excess twine which is extending from the twine arm more than 12" (305 mm). See Fig. 24.

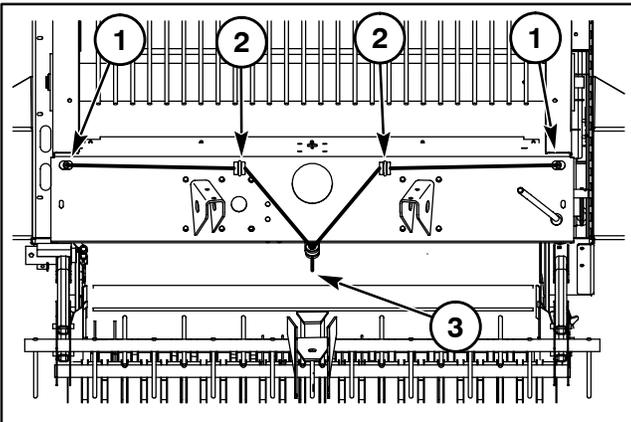

- 1 - Twine exiting twine tubes in front frame
- 2 - Twine routed into guides on hitch assembly
- 3 - Twine routed into rope guide to twine arm (both twines)

**Fig. 23: Front Twine Routing on 2780 and 2880 Balers**

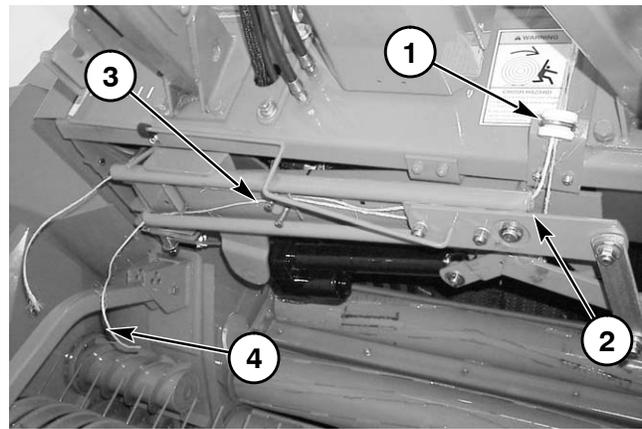

- 1 - Twine from twine guide
- 2 - Twine into twine arm
- 3 - Twine through twine tension plate and between the two spring-loaded bolts
- 4 - 12" (305 mm) twine tails

**Fig. 24: Twine Routing on Twine Arm (all models)**

**NOTE:** After the first bale has been tied, the twine (extending from the twine arm) will be held by the twine jaws, after cutoff. The twine jaws should provide an 18" (457 mm) tail of twine to start the twine on the bale.

## Start-up



# WARNING

**BE SURE all bystanders are away from the baler, all tools and other objects have been removed from the baler, and the windrow is clear of all obstacles BEFORE proceeding. In addition, BE SURE that the PTO shafts turn freely inside their shield tubes before starting the tractor.**

After the baler is properly connected to the tractor, start the tractor and run the PTO at a slow tractor RPM. Raise and lower the tailgate a few times to purge the hydraulic system of air and to make sure the tailgate opens and closes freely.

## TYPICAL BALING CYCLE

### Preparing Crop To Be Baled

There is a wide variety of crops that can be round baled. To prevent premature failure of the baler and costly repairs, it is recommended that the crop is prepared and cured to a condition that can be best handled by your baler. Damp and high moisture crops can result in difficult baling. It is recommended that the silage special models are used for these conditions.

To make dense, good looking bales, it is important that the entire width of the bale chamber is filled evenly from side to side. To get a good firm bale, it is also important that the crop is packed to the extreme outside edges of the bale chamber. This can be accomplished several ways. One way is to weave from one side of the windrow to the other, filling the entire width of the baler. This method is usually used when crop conditions are light and the windrow is prepared narrower than the width of the baler (see following topic, Preparing the Windrow).

**NOTE:** *It is very important that when starting a bale core in narrow windrows, that you weave rapidly from one side of the windrow to the other, filling both sides of the baler as quickly as possible.*

The optional steering monitor will assist the operator in making evenly built bales. The steering monitor directs the operator when to steer from side to side so that the crop is evenly placed in the bale chamber to make even bales.

When baling in heavier crop conditions, the windrow can be prepared to the width of the bale chamber. This is done by adjusting the crop deflectors on the mower conditioner to the desired width, or to rake the crop into a windrow width that is slightly wider than the bale chamber.

### Preparing the Windrow

Crop being prepared for round baling should be windrowed into a 48 or 24" (1219 or 610 mm) windrow for balers equipped with a four foot (1.2 m) width pickup. Crop being prepared for round baling should be windrowed into a 61 or 36" (1549 or 914 mm) windrow for balers equipped with a five foot (1.5 m) width pickup. Crop should be windrowed into a 84 or 42" (2134 or 1067 mm) windrow for balers equipped with the wide-width pickup. All crops should be severed from their roots. Corn stalks, straw and other brittle materials should be raked into a full-width windrow, since these materials tend to break-up and deteriorate due to side sheet friction. In addition, the wider windrow will reduce crop loss and trash build-up.

**NOTE:** *Improper windrow widths result in irregularly shaped bales because of material overlap in the center of the bale. Narrow windrow widths will require a weaving path across the windrow to assure even crop distribution as the bale is formed.*

## Initial Field Adjustments

### A: Pickup Height

After transporting the baler to the field, adjust the pickup height according to crop conditions and land contour. The baler pickup should be run as high off the ground as possible while still being able to completely pick up all of the crop. Optional gauge wheels are available on clean sweep pickups when baling in uneven conditions.

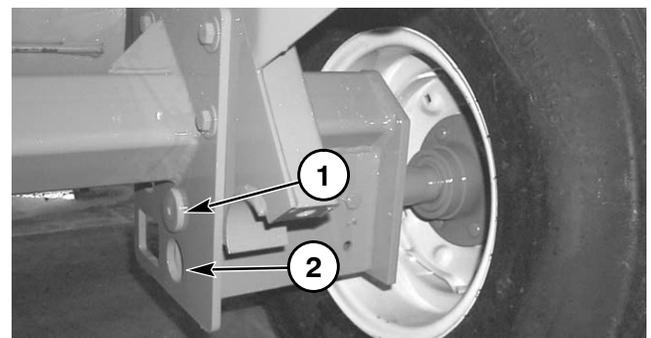

- 1 - Standard axle position
- 2 - Lower axle position

**Fig. 25: Axle Adjustment Settings**

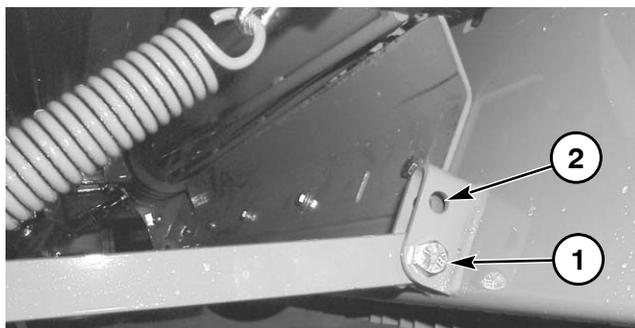

- 1 - Standard push link position
- 2 - Upper push link position

**Fig. 26: Pickup Lift Height Range**

On some later model balers, the axle provides two adjustment settings as shown in Fig. 25. The standard position will accommodate most baling conditions. For some situations, such as soft terrain, terraces, or tall stubble, the spindle can be moved to the lower position to raise the baler 2-3/8" (60 mm). When making this adjustment, the pickup lift height range can also be adjusted as shown in Fig. 26. Attaching the push link to the upper hole will permit the pickup to drop closer to the ground, but will increase float effort. It is recommended that the drawbar clevis also be adjusted to level the baler.

**IMPORTANT:** *The pickup assembly MUST be carried off the ground. Running the pickup too low to the ground will result in excessive tine wear or breakage, possible damage to the pickup components, and shearing bolts on units equipped with a pickup clutch or drive belt slippage on belt-driven units.*

On the 2480 and 2780 models, the pickup is raised by using the hand lever and placing the pin in the lowest hole in the adjustment arm. See Fig. 27.

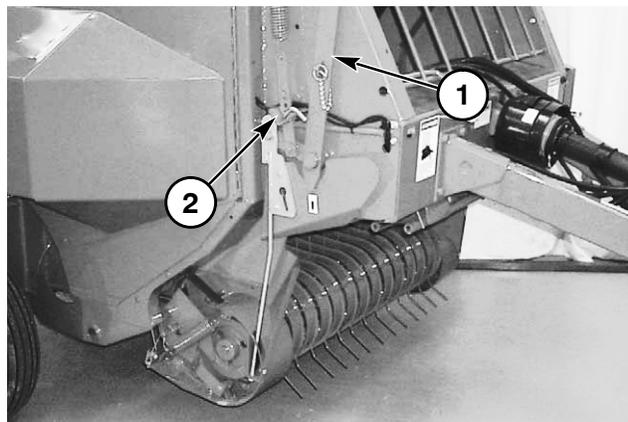

- 1 - Pickup lift hand lever
- 2 - Adjustment locking pin

**Fig. 27: 2480 with Pickup in "Transport" Position**

On the 2580, 2680 and 2880 models, the pickup is raised by turning the hand crank in a clockwise direction and lowered by turning the hand crank in a counterclockwise direction. See Fig. 28.

**IMPORTANT:** *The hand crank settings act as the lower limit stop for the hydraulic lift kit. BE SURE to reset this setting when resuming baling.*



- 1 - Pickup lift hand crank

**Fig. 28: 2680 Baler with Optional Wide Pickup in "Transport" Position**

### B: Initial Bale Size

On manual twine control equipped balers, bale size is determined by observing the bale size visual indicator on the front of the baler. See Fig. 30 for location.

On balers equipped with the auto twine control system or the auto bale control system, each control system has its own Operator's Manual and bale size settings are described in each respective manual.

### C: Windguard (Fig. 29)

The windguard for the pickup has three adjustment points. The adjustment of the hanger arm is with a pin controlling the height of the pivot point of the windguard. The pin should be in the uppermost location for heavy or tall stubble crops. Lower positions are for lighter crops or windy conditions. There are also two wire lock pins limiting the windguard's upper and lower pivoting motion. Adjustments made to the windguard should be the same on each side.

The windguard may be quickly removed for ease of adjustment or unplugging by releasing the latches on either end.

## WARNING

**NEVER operate the baler unless the windguard is in place and properly adjusted.**

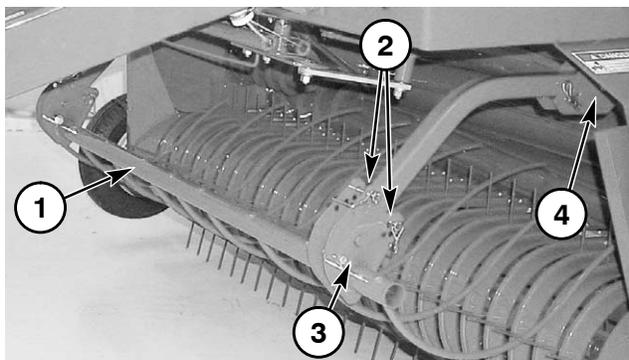

- 1 - Windguard
- 2 - Upstop/downstop wire lock pins
- 3 - Windguard latch
- 4 - Windguard pivot point

Fig. 29

### Beginning Baling

Move the baler into position with respect to the windrow and BE SURE to check the path in front of the pickup and ahead of the baler before starting to bale. Then start the PTO. Slowly bring the tractor RPM up to the desired operating speed and begin baling.

If the windrow has been prepared to less than the full width of the bale chamber, it will be necessary to drive the baler in a weaving fashion to start the core and evenly fill the chamber. If the windrow has been prepared for the full width of the pickup, 48" (1219 mm) or 61" (1549 mm) for the standard and clean sweep pickups or 82" (2083 mm) for the wide clean sweep pickup, the baler can be driven straight down the

windrow, while observing that the bale starts and continues to form properly. To obtain the most uniform bales, the windrow should, whenever possible, be made at or slightly larger than the bale chamber width.

When baling a windrow that is about 1/2 the width of the bale chamber, and after the core has started, stop the weaving process and drive straight with the windrow entering the pickup as far to one side as possible. Continue driving the baler with the windrow entering on one side until the rotating bale is approximately 3-4" (76-102 mm) higher on one side than the other. Then, quickly cross over so that the windrow enters on the other side of the pickup and continue filling that side until it is 3-4" (76-102 mm) higher than the other side. Continue crossing over from side to side until a full-sized bale is formed. Continually weaving back and forth will tend to form an uneven bale

When baling a windrow that matches the full width of the bale chamber, drive straight down the windrow until the desired full-sized bale is formed.

**IMPORTANT:** *Continuous feeding of material provides for smoother starting and better bale formation. Avoid non-cylindrical bales and bales with loosely packed outside edges. Both conditions can allow the belts to fall off the ends of the bale and possibly tear out the belt lacing. In addition, this type of bale will weather poorly. Proper material preparation is a very important factor in making good-shaped bales.*

**NOTE:** *On balers not equipped with the optional bale ramps or bale kicker, it may be necessary to back up several feet before ejecting the bale to allow for room to pull ahead, close and latch the tailgate, without contacting the crop windrow.*

### Balage (High Moisture Hay) (2580 and 2680 Silage Special Models)

**NOTE:** *Anyone experimenting with this type of storage procedure for the first time should do so with limited samples to minimize potential losses. Consult your local agent or university to determine if the baling of high moisture crop has a place in your operation.*

**NOTE:** *Due to the extremely HEAVY bale that results from high moisture baling, we recommend that equipment used to transport these heavy bales be rated for the load. It is further recommended that high moisture baling be limited to using only a 2580 or 2680 Silage Special Baler that is already equipped to handle high moisture crop.*

## Bale Size Visual Indicator (Fig. 30)

The maximum achievable bale size is 5' (1.5 m) in diameter for the 2480, 2580 and 2780 Balers, and 6' (1.8 m) in diameter for the 2680 and 2880 Balers. These are all variable-chamber balers. Therefore, the bale forming process can be stopped at any time before this size. For this reason, the bale size visual indicator is provided as an aid to forming consistent-sized bales.

The belt tension and subsequent bale density is controlled by the Total Density Control (TDC<sup>®</sup>) system. The major components of this system include a reservoir, two density control cylinders, an adjustable pressure relief valve, and a manifold with a trip mechanism. This unique TDC system is self-contained and is completely independent of the tractor hydraulic system. The TDC system supplies a tensioning force to the belts which, in turn, exert a compressive force on the forming bale.

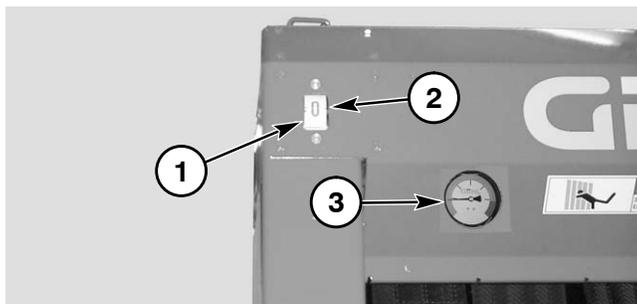

- 1 - Bale size visual indicator
- 2 - Pointer
- 3 - TDC operating pressure gauge  
(2580, 2680 and 2880 only)

**Fig. 30**

During the initial bale forming stage, the force exerted by the density control cylinders onto the belts is directly related to the air pressure in the reservoir. As the bale increases in size, the additional belting required is released by the belt shuttle as it moves toward the rear of the baler. This rearward travel of the belt shuttle extends the density control cylinders and forces hydraulic fluid out of the cylinders, through a manifold and into the reservoir. This additional fluid further compresses the air in the reservoir and causes an increase in pressure, resulting in increased belt tension.

## Function of TDC System (Figs. 31, 32 & 34)

As the cylinders continue to extend, the valve trip mechanism is contacted by the trip spacer on the trip arm of the right density control cylinder clevis. As the valve trip mechanism is triggered, the free flow path through the manifold is blocked off and the hydraulic fluid is

redirected through the adjustable pressure relief valve on its way to the reservoir. The relief valve works to create a pressure differential between the density control cylinders and the reservoir. This means that the fluid pressure in the density control cylinders has to reach a preset value above the pressure in the reservoir before the relief valve will relieve and allow the fluid to pass through to the reservoir.

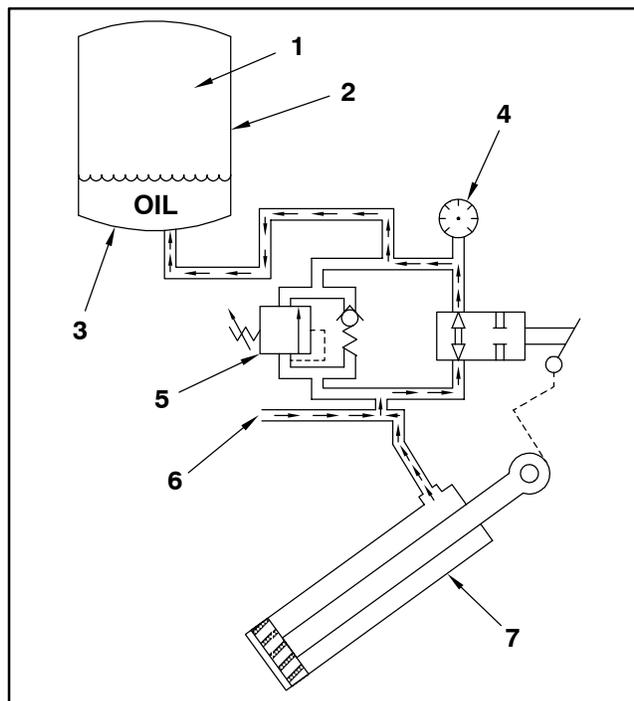

- 1 - Air pressure
- 2 - Pressurized reservoir
- 3 - Oil
- 4 - Pressure reading of 170 PSI (1172 kPa)  
(shuttle returned)
- 5 - Adjustable relief valve setting:  
2480 - 300-450 PSI (2068-3103 kPa)  
2580, 2680, 2780 & 2880 - 300-550 PSI  
(2068-3792 kPa)
- 6 - To left cylinder
- 7 - Shuttle cylinder

**Fig. 31: Core Formation Detail**

As the bale continues to grow and the cylinders continue to extend, the TDC system continues to function in the manner previously described. When the bale is ejected from the baler, the pressure in the line from the density control cylinders to the relief valve drops below the pressure in the reservoir. This causes a reverse flow of hydraulic fluid from the reservoir back into the density control cylinders. The cylinders are retracted, which in turn restores the shuttle, the belts and the valve trip mechanism to their original positions. The TDC system is once again ready to start forming another bale.

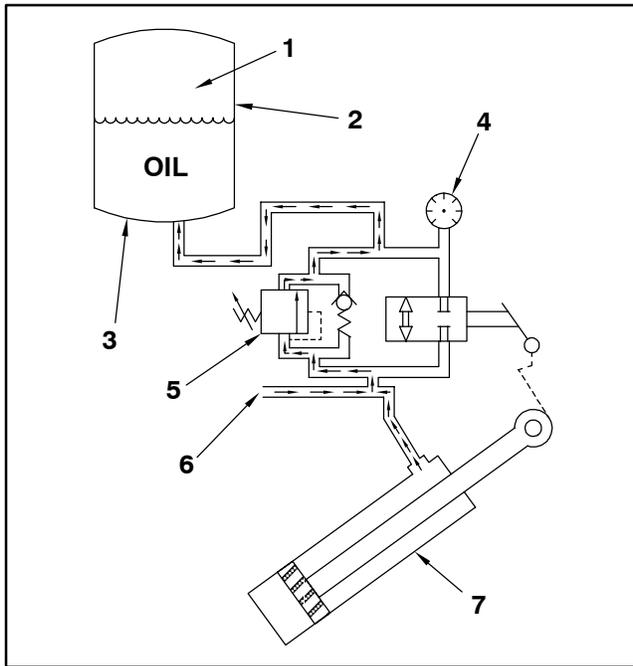

- 1 - Air pressure
- 2 - Pressurized reservoir
- 3 - Oil
- 4 - Pressure reading of 170 PSI (1172 kPa)
- 5 - Adjustable relief valve setting:  
2480 - 300-450 PSI (2068-3103 kPa)  
2580, 2680, 2780 & 2880 - 300-550 PSI  
(2068-3792 kPa)
- 6 - To left cylinder
- 7 - Shuttle cylinder

**Fig. 32: Bale Building  
(Beyond Core Formation) Detail**

Trip Arm Position (See Fig. 33)	Diameter of Bale Core
1 (top)	16
2	23
3	27
4	33
5 (bottom)	36

### TDC Valve Trip Mechanism (Fig. 33)

The valve trip mechanism can be used to independently adjust the air-pressure-controlled bale core diameter. To increase the softer core diameter, adjust the trip spacer to a lower hole.

**NOTE:** For additional details on the advantages of making a trip spacer adjustment, refer to the Core Size adjustment topic in the Care & Maintenance chapter.

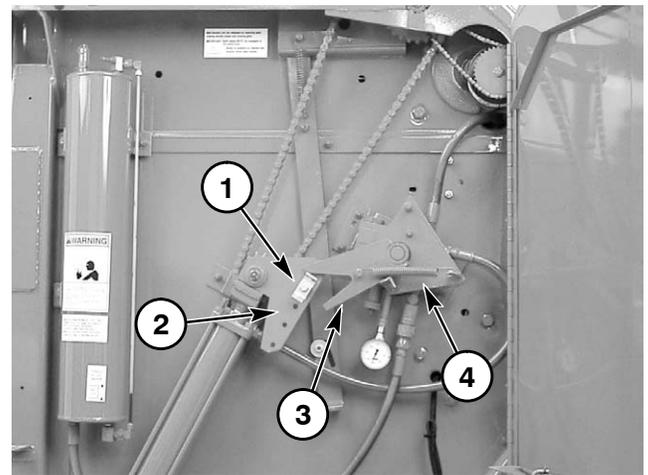

- 1 - Trip spacer (in position 1)
- 2 - Trip arm
- 3 - Valve trip
- 4 - Valve trip mechanism

**Fig. 33**

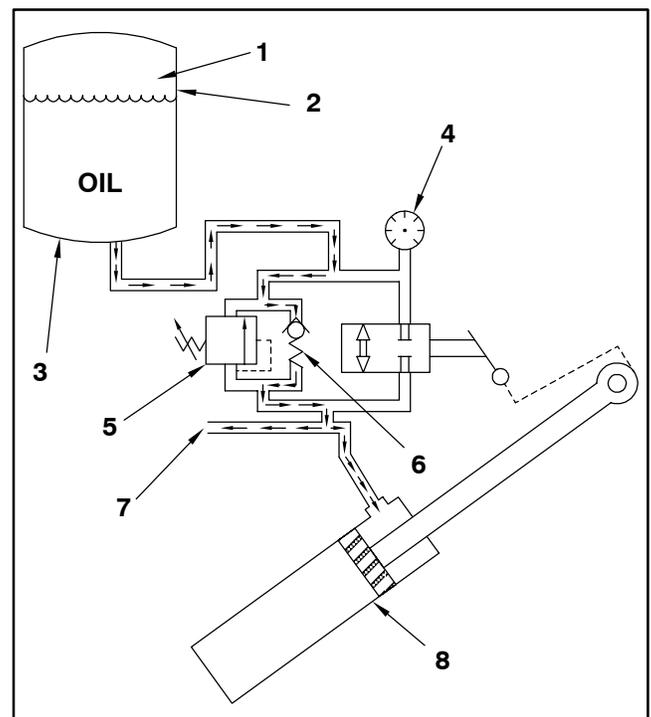

- 1 - Air pressure
- 2 - Pressurized reservoir
- 3 - Oil
- 4 - Pressure reading of 290 PSI (1999 kPa)
- 5 - Adjustable relief valve setting:  
2480 - 300-450 PSI (2068-3103 kPa)  
2580, 2680, 2780 & 2880 - 300-550 PSI  
(2068-3792 kPa)
- 6 - 15 PSI (103 kPa)
- 7 - To left cylinder
- 8 - Shuttle cylinder

**Fig. 34: Bale Ejecting &  
Shuttle Return Detail**

## TDC Pressure Gauge (Fig. 30)

On 2580, 2680 and 2880 models, the baler is equipped with a TDC pressure gauge to inform the operator of the working pressure in the density cylinders when building a bale.

## TDC Pressure Relief (Fig. 35)

A pressure relief valve is provided on top of the TDC reservoir to automatically release excessive (beyond 300 PSI or 2068 kPa) pressure build-up. The relief valve helps to prevent TDC system component damage. Filling the reservoir beyond the recommended level will cause the pressure level to exceed 300 PSI (2068 kPa).

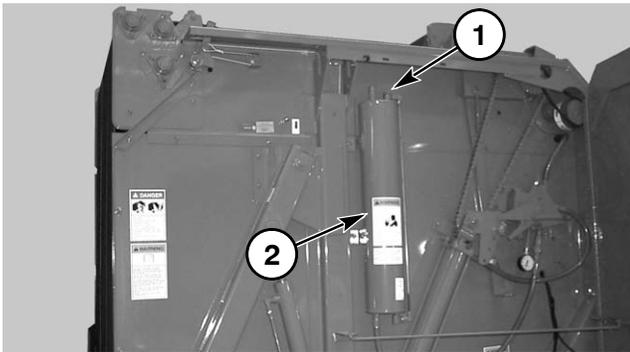

1 - Pressure relief valve  
2 - Total density control (TDC) reservoir

Fig. 35

## Overfill Protection

On 2480 and 2780 models, the balers are designed with overfill mechanisms that automatically stop the pickup when the bale becomes oversized. See the Overfill topic in the Adjustment section of the Care & Maintenance chapter.

**IMPORTANT:** On units equipped with the auto twine control or auto bale control, BE SURE that the bale size sensors are set to start the tie/wrap cycle BEFORE the overfill is tripped.

When the bale becomes oversized, the shuttle will activate the overfill lever, which is linked by a cable to the pickup drive belt idler, to stop the pickup and prevent damaging the baler. When this happens, back the baler out of the windrow, and tie the bale manually by exercising the MANDATORY SAFETY SHUTDOWN PROCEDURE (page 8), pulling the twine from the twine arm and placing it between the power feed rolls. Push the recycle button on an auto twine control unit and start the baler. Finish the tie cycle before ejecting the bale. The belt idler returns to normal operation when the tailgate opens and the shuttle starts to return.

On 2580, 2680 and 2880 models, the pickup will not disengage when the baler is overfilled. When the bale becomes oversized, the shuttle will activate the overfill tie cycle. Finish the tie cycle before ejecting the bale.



**NEVER manually feed the baler when it is running. Material feeds into the baler faster than you can react to release it. You will become entangled in moving belts, pick-up or rollers. Failure to heed can result in death or serious injury.**

## Wrapping The Bale

### A: Manual Twine Wrap (Figs. 30, 36 & 37)

**NOTE:** The procedure described is the manual sequence. The entire process of wrapping the bale with twine is done from the tractor seat.

The position of the pointer on the bale size indicator can be used as an accurate gauge for forming the desired size bale. When the desired size bale is formed, stop baler forward travel. Then, swing the twine arm so that it is directed straight back towards the bale. The twine arm indicator will aid in visually determining the position of the twine arm. See Figure 37.

**NOTE:** The twine arm is actuated by moving the twine arm positioning switch to the "FORWARD" position to move the twine arm from right to left. moving the twine arm positioning switch to the "REV" (reverse) position moves the twine arm from left to right. See Fig. 36. By moving the twine arm to the middle of the baler, appropriate lengths of twine are brought out for starting to wrap a new bale.

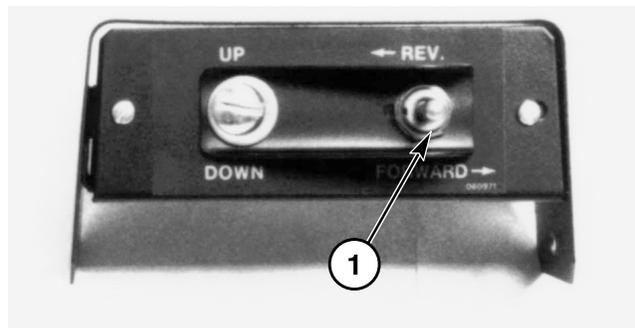

1 - Twine arm positioning switch

Fig. 36

Then, drive forward again to take in a small amount of crop material to start feeding the twine into the baler.

## DANGER

**NEVER attempt to clean or manually feed the baler when it is running. Material feeds into the baler faster than you can react to release it. You will become entangled in moving belts, pickup or rollers. Failure to heed can result in death or serious injury.**

When the twine can be seen moving into the twine arm, stop baler forward travel. Allow the twine to make at least one full wrap in this location and then move the twine arm to the far left side of the baler against the stop.

**NOTE:** *Moving the twine arm all the way to the left engages and locks the twine cutoff jaws in the open position.*

**NOTE:** *Normally, the bale can be adequately tied with two wraps of twine on the left side, several wraps across the center of the bale and two wraps on the right side. If the material being baled is slippery, it will be beneficial to place two wraps of twine on the center of the bale before moving to the left side in order to prevent the twine from sliding off the end of the bale. It may also be necessary to adjust the positions of the end wraps depending on the crop being baled. Use the twine arm indicator to position the twine arm.*

Stop the twine arm just short of the trip lever to put the right end wraps on the bale before cutting the twine. Use the twine arm indicator to manually locate the position of the right end wraps. When the twine arm returns all the way to the right, the twine jaws will snap closed and the twine will be cut. The wrapped bale can now be ejected from the baler and baling can resume.

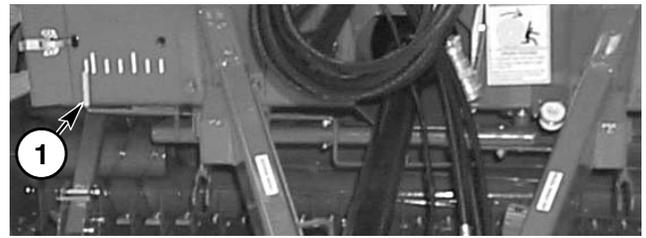

1 - Twine arm position indicator

Fig. 37

## Bale Counter (Fig. 38) (Manual Twine Wrap System Only)

The manual control baler is provided with a bale counter which indicates the number of times the TDC fork has been tripped. The bale counter is located behind the large hinged covers on the right side of the baler.

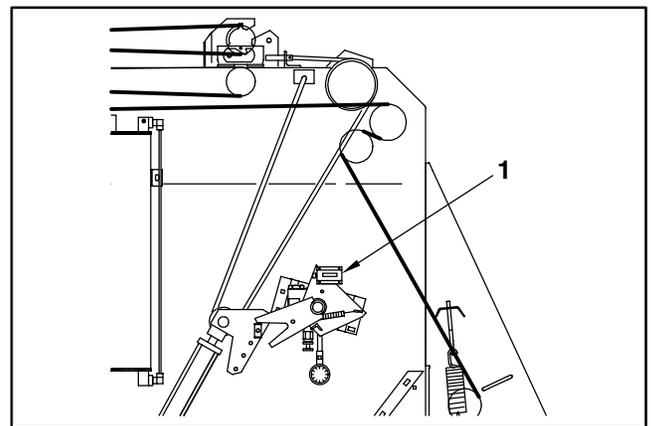

1 - Bale counter

Fig. 38

### B: Automatic Twine Wrap System

The auto twine wrap control system is covered in its own Operator's Manual.

### C: Automatic Bale Control System

The auto bale control system is covered in its own Operator's Manual.

## Bale Ejection and Handling

### **WARNING**

Bales made with a round baler are **LARGE, CYLINDRICAL and HEAVY!** When ejected on a flat surface, the momentum of the bale coming out of the baler, off the bale discharge ramps or bale kicker, could carry the bale as far as 10' (3 m) behind the baler. On a hill or incline, this distance could be much farther. **Serious personal injury or property damage could result if the bale is ejected and allowed to roll away uncontrolled! BE SURE that the tractor used with any bale handler is large enough to safely handle the weight of the bales.** Front or rear counterweights may be required. Using a bucket-type front end loader to move bales creates a hazard, because the bale can roll out of the bucket and down the loader arms onto the operator. Generally, agricultural tractor Roll-over Protective Structures (2-post ROPS) are not intended to protect against falling bales. Do **NOT** lift round bales with the standard loader unless you have proper bale restraining devices.

The following procedure should be followed, in sequence as described, for ejecting a bale:

1. On units not equipped with bale ramps or bale kicker, back the baler a short distance away from the windrow.

**NOTE:** *Stopping the PTO while opening the rear tailgate could result in a cleaner looking bale.*

2. Activate the tractor hydraulic control lever and fully extend tailgate cylinders to open tailgate.
3. Allow the bale to roll out.
4. On units without the bale kicker or bale ramps, drive the baler ahead.
5. Close the tailgate by retracting the tailgate cylinders.

**IMPORTANT:** *BEFORE closing the tailgate, BE SURE that the bale has rolled free of the baler to prevent it from being pulled back into the baler by the tailgate and moving belts. Damage to the starting finger assembly can occur.*

**IMPORTANT:** *BE SURE to fully retract the tailgate cylinders to allow the tailgate latches to engage and lock. The PTO should be kept running while closing the tailgate to reduce the possibility of belt damage.*

### Overload Protection

#### A: PTO (Fig. 39)

Some balers may be equipped with a standard 540 RPM PTO drive line which is protected with one 1/4 x 1-1/2" Grade L9 shear bolt.

Four extra shear bolts and lock nuts are stored in a holder under the drive shield. Replacement shear bolts and lock nuts are available in packaged quantities of (eight) per package by ordering Gehl part number 095141.

**NOTE:** *In order to achieve proper bolt shearing, the shear bolt MUST be installed so that the bolt shears through the body of the bolt and not the threads. Place the bolt in the drive line from the baler toward the tractor. See Fig. 39.*

**IMPORTANT:** *Grease the shear device on a timely basis as recommended in the Lubrication section of the Care & Maintenance chapter and lubrication decals located on the baler. BE SURE to remove the cause of the overload before restarting the baler.*

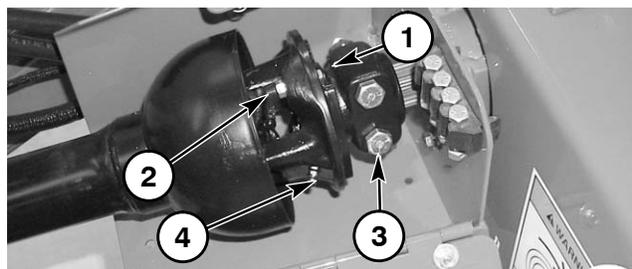

- 1 - Shear bolt head positioned to shear through bolt body
- 2 - Threaded end of shear bolt with lock nut
- 3 - Implement end of PTO
- 4 - Grease fitting for shear device

**Fig. 39: Shear Bolt Protected**

Balers equipped with the heavy-duty PTOs are protected by a slip clutch or automatic disconnect clutch. The slip clutches are not adjustable.

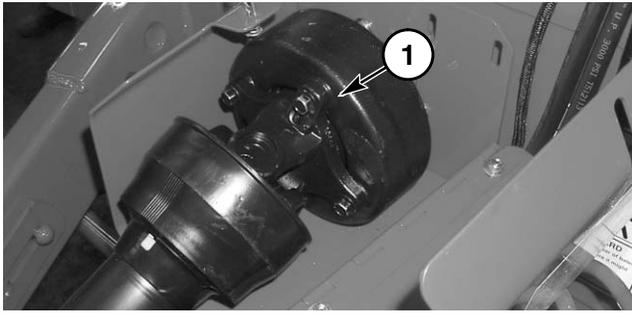

1 - Disconnect clutch

**Fig. 40: Disconnect Clutch**

On balers equipped with the 540 RPM heavy-duty drive, the driveline is equipped with an automatic disconnect clutch as shown in Fig. 40. The clutch will remove power from the baler when an overload is experienced. After the cause of the overload is removed, the clutch can be re-engaged by idling or bringing the tractor PTO to a complete stop.

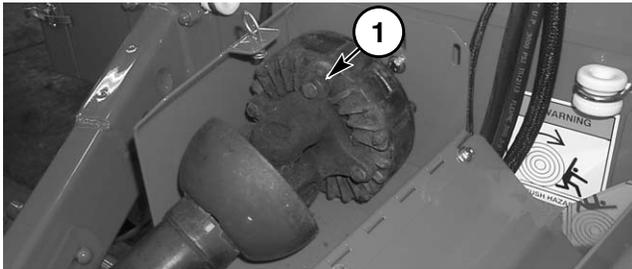

1 - Slip clutch

**Fig. 41: Slip Clutch**

**B: Pickup Clutch (Figs. 42 & 43)**

On 2580, 2680, and 2880 model balers, the pickup is protected by a ratchet clutch device that does not provide mechanical chamber overload protection. See Fig. 43. Do not operate ratchet clutch for more than a few seconds at a time when slipping, because this may cause premature clutch failure.

**IMPORTANT:** Grease the ratchet clutch on a timely basis as recommended in the Lubrication section of the Care & Maintenance chapter and lubrication decals located on the baler. BE SURE to remove the cause of the overload before restarting the baler.

---

**! WARNING**

**ALWAYS** use genuine Gehl replacement service parts to assure safe operation of the baler.

---

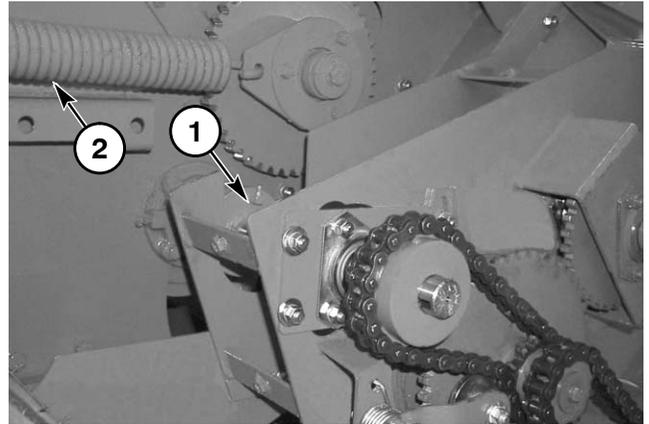

1 - Wide pickup drive ratcheting clutch  
2 - Spring for pivoting power feed roll

**Fig. 42: Wide Pickup Ratchet Clutch**

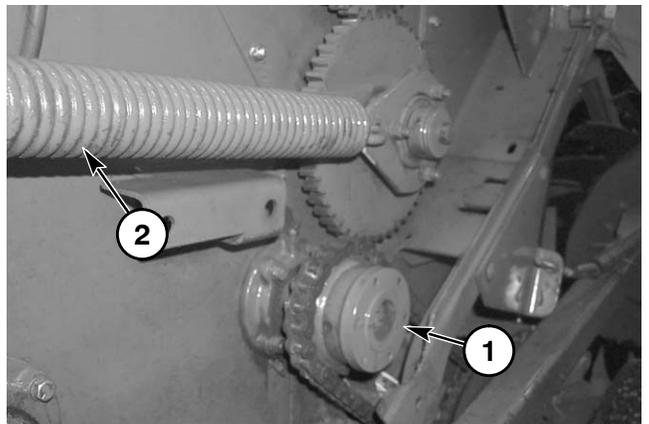

1 - Standard pickup drive ratcheting clutch  
2 - Spring for pivoting power feed roll

**Fig. 43: Standard Pickup Ratchet Clutch**

## Unplugging & Trash Removal (Figs. 44, 45 & 46)

If the baler becomes plugged, the following procedure **MUST** be used to safely clear the baler:

1. Back out of the windrow.
2. Disengage the tractor PTO.
3. Open the tailgate if necessary, locking the tailgate open by turning tailgate cylinder lockout valve (See Figs. 6 & 7).
4. Exercise the **MANDATORY SAFETY SHUTDOWN PROCEDURE** (page 8).



## DANGER

**ALWAYS exercise the MANDATORY SAFETY SHUTDOWN PROCEDURE before unplugging or removing trash from the baler.**

---

5. Proceed to the area of the plug and remove it. Open any guards and shields required to gain access to the plugged area.
6. Remove the windguard. The windguard is a quick-disconnecting guard that can be removed by releasing the latch on each end of the windguard.
7. Pull out loose material from on top of plugged material.
8. Check other areas of the baler for plugged material and remove. Crop may be pulled under power feed roll scrapers during a plug. Remove crop from around these scrapers. Look for possible causes of the plugging and repair as required.
9. When the material becomes hard to pull out of the pickup, place the reversing wrench on the cross shaft and press downwards on the wrench (Fig. 45). This will rotate the pickup and power feed rolls backwards, backing the material out of the pinch points between power feed rolls and pickup.

**NOTE:** *In extreme situations, an object may become lodged between the power feed rollers. It may be necessary to remove the spring tension on the pivoting power feed roll. Loosen jam nut and nut on the spring anchor to release spring tension. See Figure 42. BE SURE to re-tension spring before resuming baling.*

10. If you have been successful in unplugging the baler in Step 9, proceed to Step 11. Occasionally you may be unable to reverse the baler by hand using the reversing wrench. In some cases, it will be necessary to eject the partially completed bale in order to gain access to the inside of the Baler. When this occurs, the following steps **MUST** be followed:

- a. Remove the reversing wrench and return it to its proper storage position.
- b. Reconnect the PTO disconnected in Step 4.
- c. Start tractor, engage PTO and eject the partial bale that is formed in the chamber. The partial bale can be unrolled and re-baled.
- d. Again exercise the **MANDATORY SAFETY SHUTDOWN PROCEDURE** (Page 8).
- e. With the power feed rolls cleared, go under the raised and locked tailgate and remove as much material as possible from the rear of the baler and inside the bale chamber.



## WARNING

**NEVER go under a raised tailgate without first placing the tailgate cylinder lockout valve in the locked position. See Figs. 6 & 7 for details.**

---



## DANGER

**DO NOT put your hands or feet between the pivoting power in-feed roll and lower power in-feed roll. NEVER use your hands or feet to dislodge crop from between the power feed rolls and lower feed roll. The pivoting power in-feed roll is spring-loaded downward and will entrap you.**

---

11. After material is unplugged from the feed roll/pickup area, remove any trash that may have built up on top of the belts or on top of the starter finger assembly.
12. Rotate the starter finger assembly upward by hand making sure that none of the fingers make contact with the stripper roll. If any of the fingers touch the stripper roll, they **MUST** be straightened **BEFORE** operation can continue.

13. AFTER unplugging, replace the windguard and any removed guards and shields, place the tailgate cylinder lockout valve in the open position and return the reversing wrench to its proper storage position. Check and replace any sheared bolts.

## **WARNING**

**ALWAYS** remove the reversing wrench from the cross shaft and return it to its storage location **BEFORE** resuming baler operation.

14. Go through the proper start-up procedure, engage tractor PTO at a low RPM and close and latch the tailgate.

**NOTE:** If the baler is equipped with an auto bale control system, the “GO ARROW” icon **MUST** be visible on the tractor control module **BEFORE** baling can resume. If the “GO ARROW” icon is not visible, switch to the manual mode and move the twine arm away from the “home” position several inches (until the cycle icon flashes on and off). Return the twine arm home to stall (until the flashing cycle icon disappears). With the PTO running, open the tailgate far enough to show the open tailgate icon and then close the tailgate again or until the closed tailgate icon appears. At this time, the “GO ARROW” icon should appear on the front of the baler icon. Switch back to the auto mode.

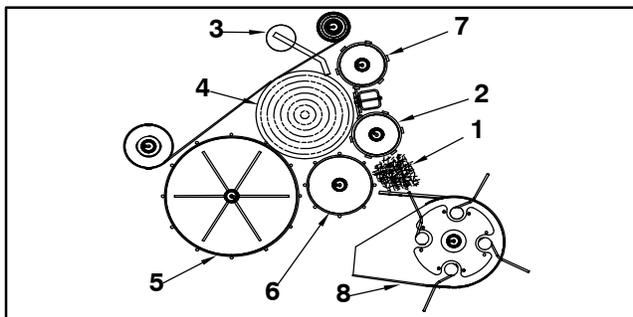

- 1 - Potential area of trash buildup
- 2 - Pivoting power in-feed roll
- 3 - Bale starter fingers
- 4 - Bale core
- 5 - 16" floor roll
- 6 - Fixed power in-feed roll
- 7 - Stripper roll
- 8 - Pickup

**Fig. 44**

Different crops and conditions may require adjusting the windguard height and tine angle. Typically, short crumbly crops require a lower setting. Try varying your

ground and PTO speeds to find a more suitable combination for the crop being baled. This condition can be encountered when baling dry straw, cane or corn stalks.

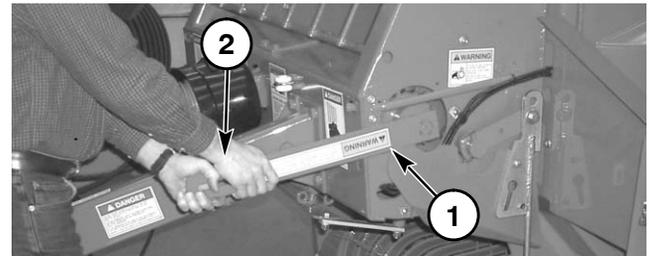

- 1 - Reversing wrench
- 2 - Direction of wrench rotation to reverse baler

**Fig. 45**

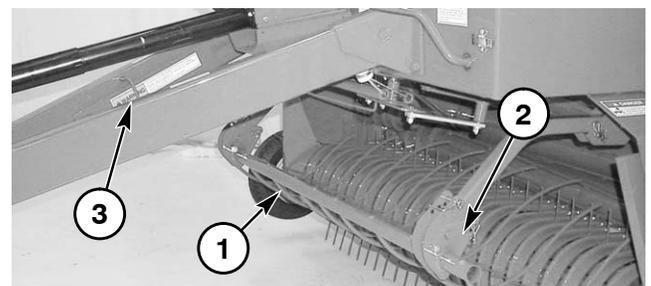

- 1 - Windguard
- 2 - Windguard retaining latch
- 3 - Reversing wrench in storage location

**Fig. 46**

## Operating Optional Equipment

### A: Bale Ramps

The bale ramps assist in rolling the bale clear of the baler when ejecting a tied or wrapped bale. Several positions are available to compensate for varying crop conditions

**IMPORTANT:** *BEFORE* closing the tailgate, **BE SURE** that the bale has rolled free of the baler to prevent it from being pulled back into the baler by the tailgate and moving belts. Damage to the starting finger assembly can occur.

**NOTE:** *Bale kicker* option cannot be used when the bale ramps are installed.

### B: Bale Kicker

The bale kicker is designed to “kick” and push a bale far enough away for the tailgate to clear the bale when closing, without the operator having to drive the tractor forward. The bale kicker becomes part of the tailgate hydraulic system and operates whenever the tailgate is opened and closed.

As the tailgate is opened, the bale kicker lowers to provide a ramp for the bale to roll down. When the

hydraulics are selected to lower the tailgate, the bale kicker raises first to hold the bale clear of the descending tailgate. If the bale has failed to clear the baler, a bale sensing lever will not allow the pushrod to contact the stop valve, thus preventing the tailgate from closing.

---



## WARNING

**The bale kicker should not be used when the slope of the field will cause the bale to roll. ALWAYS eject bale so it will be placed sideways on hilly terrain.**

---

**IMPORTANT:** *BEFORE closing the tailgate, BE SURE that the bale has rolled free of the baler to prevent it from being pulled back into the baler by the tailgate and moving belts. Damage to the starting finger assembly can occur.*

**NOTE:** *Bale ramps cannot be used when the bale kicker option is installed.*

### C: Crowder Wheels

The crowder wheels are designed to expand the usable width of the pickup on the baler to enable taking in a wider swath of material. The crowder wheels are designed to float on the ground when engaging the crop and raise to a transport position when the pickup is raised. See the Adjustments section of the Care and Maintenance chapter for flotation adjustment.

**NOTE:** *Crowder wheels cannot be used on balers equipped with the wide pickup.*

### D: Steering Monitor

The steering monitor provides a visual signal telling the operator which direction to steer the tractor in order to form consistently even-diameter round bales when baling from a windrow that is not full width in size.

**NOTE:** *The steering monitor option can be only used on balers equipped with the auto twine control or the auto bale control systems.*

### E: Pickup Gauge Wheels

The gauge wheels act like skid shoes to prevent the pickup from contacting the ground in uneven field conditions. Several positions controlling height are available to compensate for various crop and field conditions. The height is correctly adjusted when the wheels do not ride on the ground but prevent the pickup from coming in contact with the ground.

### F: Hydraulic Pickup Lift

The hydraulic pickup lift provides a means of raising and lowering the baler pickup from the tractor during operation. The pickup height can be adjusted as baling proceeds to compensate for varying crop and field conditions. The lowest limit setting for the pickup is adjusted by the hand crank.

When finished baling, ALWAYS place the pickup lift cylinder in the fully retracted position BEFORE disconnecting the baler from tractor. This way, if a baler equipped with a pickup lift kit is to be connected to a tractor with only one set of double-acting hydraulic outlets, the hand crank will override the pickup lift cylinder kit to allow baling with that tractor and to perform any required maintenance.

Even though the baler is equipped with the optional hydraulic lift kit, anytime the baler is being transported, BE SURE to raise the pickup to the transport position.

**IMPORTANT:** *The hand crank settings act as the lower limit stop for the hydraulic lift kit. BE SURE to reset this setting when resuming baling.*

**NOTE:** *The hydraulic pickup lift is available ONLY on 2580, 2680 and 2880.*

### G: Chain Oiler Installation

The chain oiler provides lubrication to the various chain drives on the baler every time the tailgate is opened. Operation of the oiler is described in the Lubrication section of the Care & Maintenance chapter of this manual.

---



## WARNING

**BEFORE installing the chain oiler kit on this unit, exercise the MANDATORY SAFETY SHUTDOWN PROCEDURE (page 8).**

---

The chain oiler kit is designed to fit more than one application. The following installation will call only for the parts that are required to provide lubrication to the various chain drives on the baler. There will be parts left over. Referring to the illustrations, install the kit by the following steps:

**Preparation (Fig. 47)**

1. On a bench, assemble the oil pump, short hose and oil tank, securing with the two hose clamps provided. The port on the pump for the hydraulic hose should be facing to your right. If necessary, install manifolds in another set of holes to properly orient hydraulic hose port.
2. Mount the pump and tank assembly to the mounting bracket, securing the pump to the bracket with the U-bolt and two 5/16" lock washers and nuts. DO NOT over-tighten u-bolt and distort or collapse pump cylinder. Secure the tank to the bracket with four 1/4 x 3/4" carriage bolts, lock washers and nuts.

**Installation (Figs. 48 through 51)**

3. Mount the tank and pump assembly to the baler, securing with two each 3/8 x 1-1/4" cap screws, lock washers and nuts. See Fig. 48.

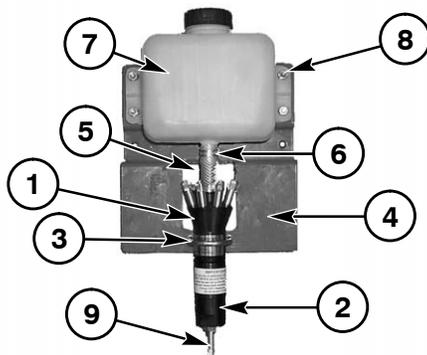

- 1 - Oil pump
- 2 - Hydraulic hose port (pointed right)
- 3 - U-bolt
- 4 - Mounting bracket
- 5 - Short hose
- 6 - Clamps (2)
- 7 - Tank and cap
- 8 - 1/4 x 3/4" (6.4 x 19 mm) carriage bolts, lock washers and nuts (4 places)
- 9 - Oil adjustment screw

**Fig. 47**

4. Install the 90° elbow into the hose port of pump with elbow facing up. See Fig. 48.

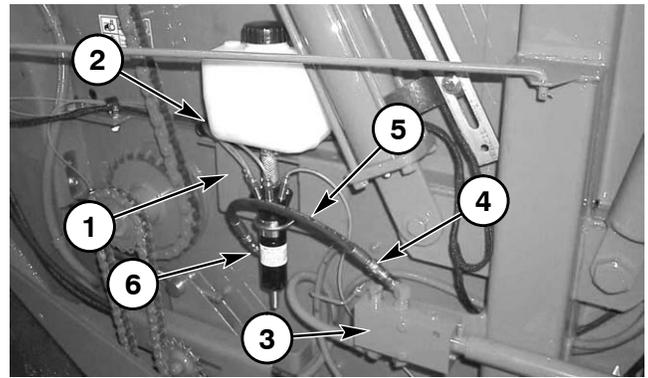

- 1 - Oiler, tank and mounting bracket assembly
- 2 - 3/8 x 1-1/4" cap screws lock washers and nuts (2 places)
- 3 - Tailgate lockout valve
- 4 - Hydraulic tee
- 5 - Hydraulic hose
- 6 - 90° elbow

**Fig. 48****WARNING**

**DO NOT** remove any hydraulic lines or fittings until you are sure that the system is depressurized and that there is no load on any hydraulic components. Failure to heed may result in personal injury.

5. After verifying that there is NO pressure in the tailgate hydraulic system and the tailgate is lowered and latched, disconnect the hydraulic hose connected to the elbow in the top rear port (port "C") of the tailgate lockout valve. Install supplied hydraulic tee and reconnect hose to the tee. Install male end of 13" (330 mm) hydraulic hose into the 90° elbow just installed in the pump and the female end to the tee just installed.
6. Referring to Figures 49 through 51, install three brackets and brushes using hardware described in each figure (four if equipped with auxiliary drive). Brushes are correctly positioned when they will rub slightly on the chain being oiled.

**NOTE:** Photos of installed oil pump show a fifth oil tube installed. This tube is used on Silage Special models to lubricate the extra chain drive on those models.

- Referring to Figures 49 through 51, install tubing routing as shown. Determine an appropriate route for the tubing that goes between the manifold and the brush. Cut tubing to length needed. Route tubing as shown and install into brush by pushing tubing into top of brush. Brush fitting will automatically grab tubing once it is inserted far enough.

**NOTE:** Should the tubing need to be released from the brush, push down on the red plastic collar that the tubing slides into, on the top of the brush, and slide the tubing out of brush. Pulling on tube without depressing red collar will damage collar.

To connect the tubing to manifolds on the pump, remove the nut and ferrule from the end of the manifold. Slip the nut and then the ferrule onto the tubing. Slide tubing into end of manifold until it stops, and then slide the ferrule and nut into manifold. Tighten the fitting. Secure tubing to machine as shown, using the provided clamp and wire ties.

- Add some clean SAE 20W, 30W, or 40W engine oil to the oil tank. Cycle the tailgate several times to verify operation and that there are no leaks.
- Turn in the adjustment screw until six threads are showing below the snugged lock nut.

This completes the oiler installation. See the Lubrication section of the Care & Maintenance chapter for operating details.

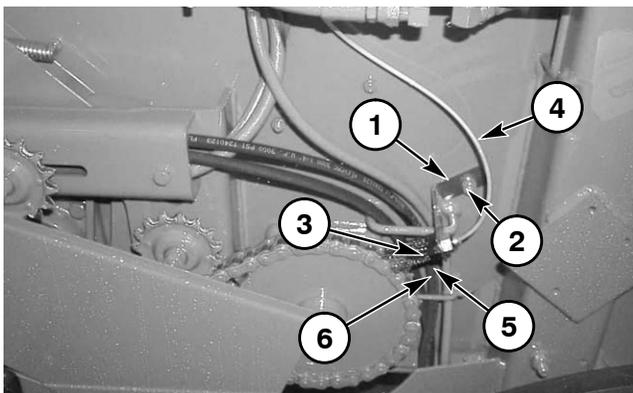

- Bracket (bend into position)
- Bracket mounting hardware (existing)
- Brush and nut
- Tubing from pump
- Wire tie securing oil tubing
- Tubing from pump (routed through axle to brush on pickup drive chain)

**Fig. 49: Brush on Floor Roller Drive Chain**

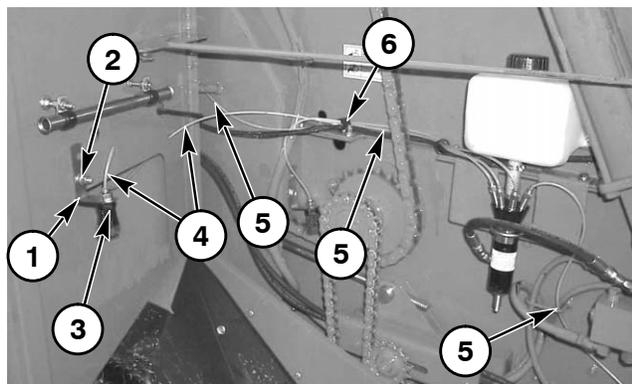

- Bracket (bend into position)
- Bracket mounting hardware (5/16" x 1" cap screw, flat washer, lock washer and nut)
- Brush and nut
- Tubing from pump routed through holes in door
- Wire ties securing oil tubing
- Clamp (mounts with existing hardware)

**Fig. 50: Brush on Power Feed Roll Drive Chain**

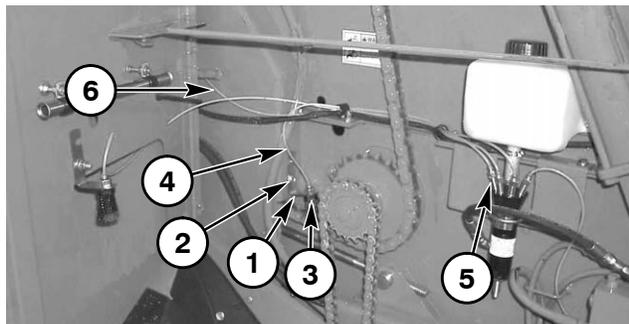

- Bracket (bend into position)
- Bracket mounting hardware (5/16" thread cutting screw and flat washer)
- Brush and nut
- Tubing from pump
- Fifth manifold and elbow as used on Silage Special balers (factory installed)
- Fifth oil tube as used on Silage Special balers (factory installed)

**Fig. 51: Brush Belt Drive Chain**

## TRANSPORTING

### Hitchjack (Fig. 52)

A hitchjack is furnished with the baler to support the machine when the tractor is disconnected, as well as to facilitate aligning the hitch clevis with the tractor drawbar for hookup.

When the jack is NOT being used to support the baler, to prevent it from being damaged by the tractor tire, it can be removed and relocated to a "Storage" position on the inside of the drawbar on the left side. Wrap the chain around the jack handle, before inserting the locking pin through the hub holes, to prevent the handle from dragging on the ground or snagging crop.

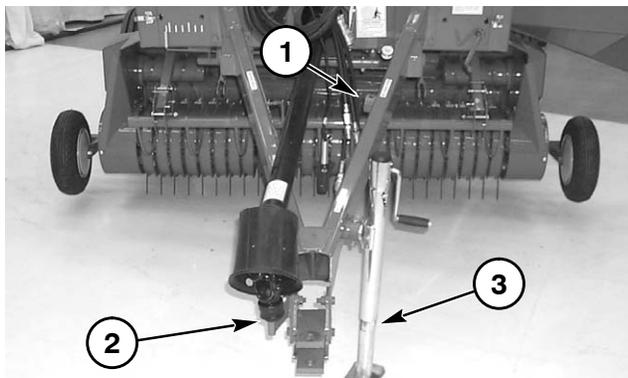

- 1 - "Storage" position for hitchjack on hub
- 2 - PTO supported on driveline storage stand (2580, 2680 and 2880 only)
- 3 - Hitchjack in "supporting" position

Fig. 52

## WARNING

**BE SURE** the locking pin is entirely and properly inserted through both hub holes on the jackstand **BEFORE** disconnecting the baler from the tractor.

### SMV Emblem & Reflectors (Fig. 53)

For safety reasons it is important to comply with applicable regulations when transporting slow-moving vehicles on public highways. The baler is equipped with a bracket for mounting the supplied Slow-Moving Vehicle (SMV) emblem. The baler is also equipped with red reflector strips as shown.

Because of the variations in safety laws for different states, provinces and localities, it may be necessary to

change the emblem bracket location. Your local Gehl dealer can assist you in determining the proper location.

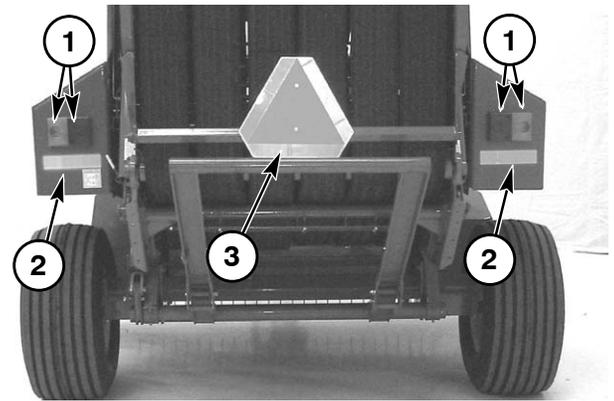

- 1 - Transport lights
- 2 - Red reflector strip (back of each twinebox)
- 3 - Slow-Moving Vehicle (SMV) emblem

Fig. 53

### Safety Chain & Transport Lighting (Figs. 53 & 54)

As required or when desired, the baler can be equipped with a safety chain for travel on public highways. Refer to the Optional Features & Accessories chapter for ordering information. The safety chain should be attached to the tractor and baler as shown. When attached in this manner, the safety chain should have the following characteristics:

1. Chain is sufficiently slack to allow turns and movements of either the tractor or the farm implement, without placing tension on chain.
2. Chain is of sufficient strength to hold the decoupled implement (and its load) and tow it to the shoulder.

## WARNING

**ALWAYS** follow state and local regulations regarding use of a safety chain and transport lights when towing farm equipment on public highways. **ONLY** a safety chain (NOT an elastic or nylon/plastic tow strap) should be used to retain the connection between the towing and towed machine, in the event of separation of the primary attaching system. **BE SURE** to check with local law enforcement agencies for your own particular regulations. **Unless otherwise prohibited, use a Slow-Moving Vehicle (SMV) emblem.**

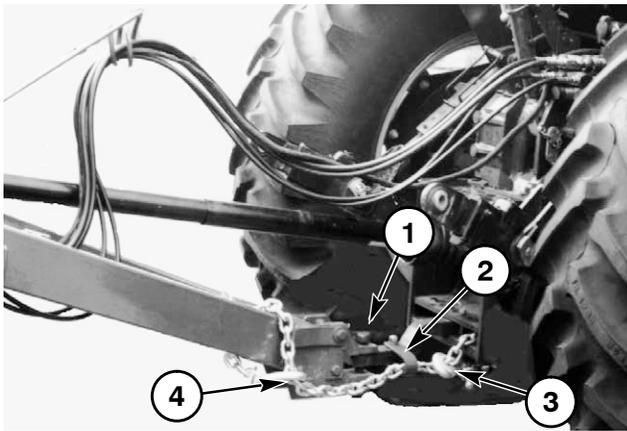

- 1 - Locking hitch pin
- 2 - Drawbar clevis (provided)
- 3 - Chain secured around tractor frame member
- 4 - Safety chain attached around baler frame

**Fig. 54**

The round balers are equipped with transport lights as standard equipment. A cord with a standard 7-pin connector to connect to the tractor is also provided. The red lights use a standard SAE #1157 bulb and the amber lights use a standard SAE #1156 bulb. If your tractor is not equipped with the proper receptacle, see your tractor dealer for details.

## Pickup (Figs. 55 & 56)

To avoid damage to the pickup, it is recommended that the pickup be raised to the transport position anytime the baler is being transported.

On the 2480 and 2780 models, the pickup is raised fully by using the hand lever and placing the pin in the lowest hole in the adjustment arm. See Fig. 55.

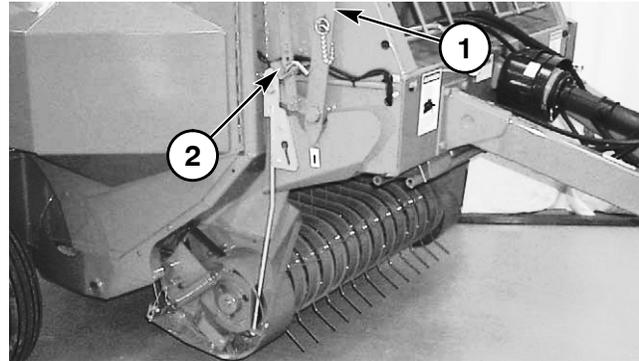

- 1 - Pickup lift hand lever
- 2 - Adjustment locking pin

**Fig. 55: 2480 with Pickup in "Transport" Position**

On the 2580, 2680 and 2880 models, the pickup is raised by turning the hand crank in a clockwise direction and lowered by turning the hand crank in a counterclockwise direction. See Fig. 56.

**IMPORTANT:** *The hand crank settings act as the lower limit stop for the hydraulic lift kit. BE SURE to reset this setting when resuming baling.*

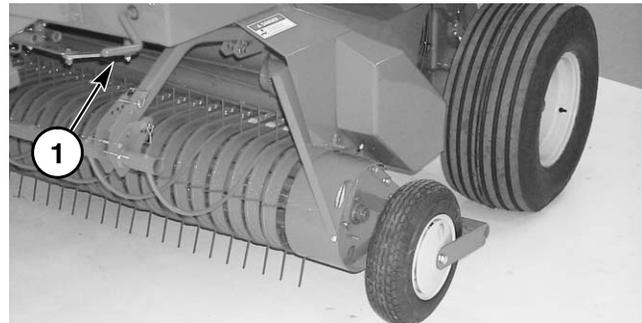

- 1 - Pickup lift hand crank

**Fig. 56: 2680 Baler with Optional Wide Pickup in "Transport" Position**

# CHAPTER 6

## CARE AND MAINTENANCE

This chapter contains information required to perform the care and maintenance expected of the owner or operator of this baler in order to keep the unit in a safe and proper operating condition. The chapter is divided into three sections:

1. Adjustments (those not required as a part of normal operation)
2. Lubrication (as part of preventative maintenance)
3. Service (component repair or replacement)

### ADJUSTMENTS



## WARNING

**BEFORE adjusting this unit, exercise the MANDATORY SAFETY SHUTDOWN PROCEDURE (page 8).**

### Bale Starter Fingers (Fig. 57)

The bale starter fingers are located between the belts and behind the stripper roll. They deflect material down and keep it from coming out over the top of the stripper roller when starting a bale. The fingers are part of a movable assembly which is held by pivoting links and positioned by a roller. A link to the tailgate lowers the assembly to a starting position after each bale is ejected. The rollers ride on the belts and are positioned by the bale. As the bale grows in size, the starting fingers follow the belts and retract until the start of the next bale.

If needed, the starting fingers can be adjusted for stripper roll clearance and for height (distance extending through the space between the belts). The clearances shown in Fig. 57 should be maintained, and may need to be changed for different conditions using item 10 in Fig. 57.

To adjust the finger extension beyond the belts, remove the positioning bolt on both sides and rotate the height adjustment cam to achieve the correct height.

To adjust the clearance between the stripping roller and starting fingers, loosen the flanged nuts and remove the positioning bolt on either side of the baler near item 5. Rotate the plates forward or rearward to obtain the desired clearance. Place the positioning bolts back into

the holes that line up. BE SURE that the bolts are in the same position on each side. Re-tighten hardware.

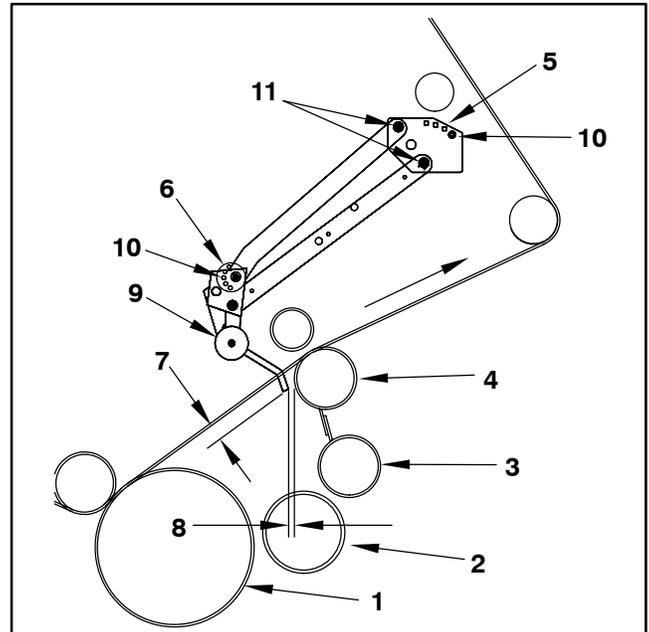

- 1 - Floor roll
- 2 - Lower fixed power in-feed roll
- 3 - Pivoting power in-feed roll in down position
- 4 - Stripper roll
- 5 - Starter finger to stripper roll clearance adjustment
- 6 - Starter finger height adjustment cam
- 7 - Adjust to 0.75-1.25" (19-32 mm) for dry baling  
Adjust to less than 0.5" (12.7 mm) for high moisture baling
- 8 - Adjust to 1-1.25" (25-32 mm)
- 9 - Rollers
- 10 - Positioning bolts
- 11 - Flanged nuts

Fig. 57

### Chain Idlers

Chain drives have adjustable idlers in two locations. All balers have an adjustable idler on the main roll drive and on the floor roller drive chains. The remaining chain drives have spring-loaded idlers and are not adjustable. When the idlers can no longer maintain tension, a link can be removed. When the idlers can no longer maintain tension and a link has already been removed, the chain is worn and needs replacement.

#### A: Roller Drive (Fig. 58)

The baler has an adjustable spring-loaded idler, which is located on the roller drive. This adjustment is provided to compensate for normal chain wear. The

## Chapter 6 - Care & Maintenance (Adjustments)

idler tension should be checked after every 50 hours of operation (or weekly) and readjusted as required. The idler tension is controlled by a tension spring that is adjusted to a length of 10" (254 mm) measured hook to hook.

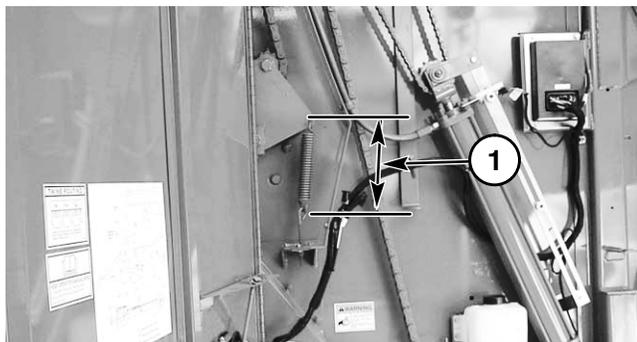

1 - 10" (254 mm) spring length, from hook to hook  
Fig. 58

### B: Floor Roller Drive Chains (Fig. 59)

The baler has a pair of adjustable idlers, which are located on the floor roller drive chains. This adjustment is provided to compensate for normal chain wear. The idler tension should be checked after every 50 hours of operation and readjusted as required. The idler tension is controlled by a manually positioned sprocket. The idlers are correctly adjusted when the strand of chain opposite the idler has less than 1/2" (12.7 mm) slack when 10 lbs. (44 N) of force is applied.

When the chain has worn or stretched to the point where the idler sprocket (Fig. 59) is almost touching the straight leg of chain, a link can be removed. Inspect the chain and sprocket for excessive wear. Replace if required. If a link has already been removed, replace the chain.

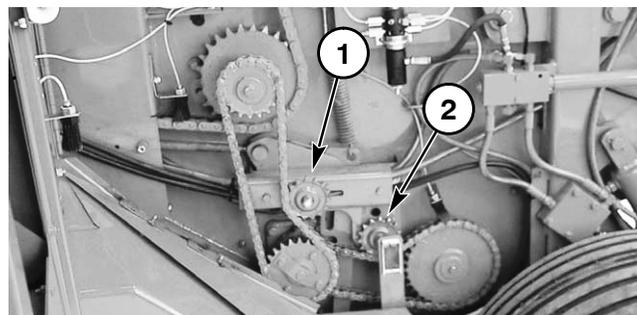

1 - Lower power feed roll drive idler  
2 - 16" (406 mm) floor roller drive idler  
Fig. 59

### Gate Latch Lift Rods (Fig. 60)

To properly adjust the gate latch lift rods on either side of the gate, simply close the gate and adjust the position of the nut on each rod so that, with the gate hooks resting on the locking pins, there is a 1/16" (1.6 mm) clearance between the nuts and barrel spacers on each side of the gate. Then, open the gate and close it again to check for correct latching; readjust if necessary. For additional information, refer to the following Gate Stops topic.

**NOTE:** *It is important that the latches on both sides of the baler be adjusted the same.*

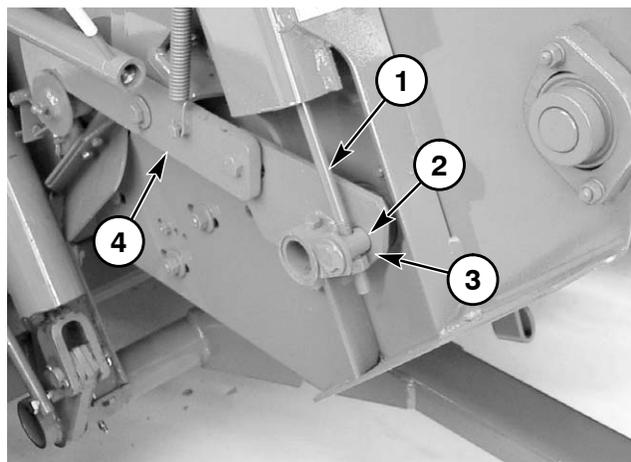

1 - Gate latch rod  
2 - Barrel spacer  
3 - Nut-to-spacer clearance of 1/16" (1.6 mm)  
4 - Left gate latch

Fig. 60

### Gate Stops (Figs. 61 & 62)

The position of the gate stops, which are located on each side of the tailgate, can be adjusted by adding or removing shims. Gate stop adjustment is only required if some of the gate components have been replaced. If necessary, shim each side so that, with the gate closed, the gate latches are ahead of the latch pins by a distance of 1/8-3/16" (3.2-4.8 mm).

**NOTE:** *After gate stops have been adjusted, it may also be necessary to readjust the gate end roller position. Refer to the "Gate End Roller" topic in the next paragraph.*

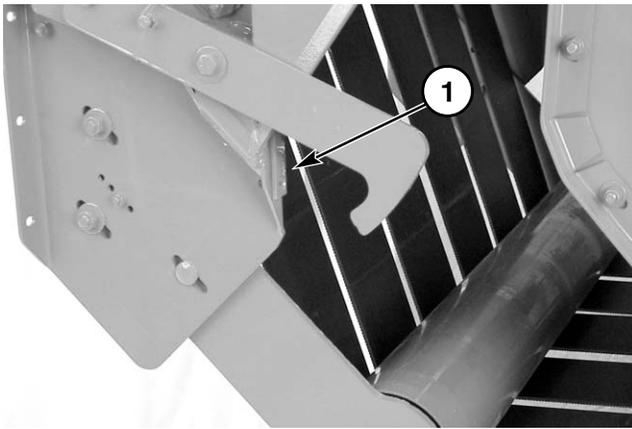

1 - Gate stop adjustment shims (each side)

Fig. 61

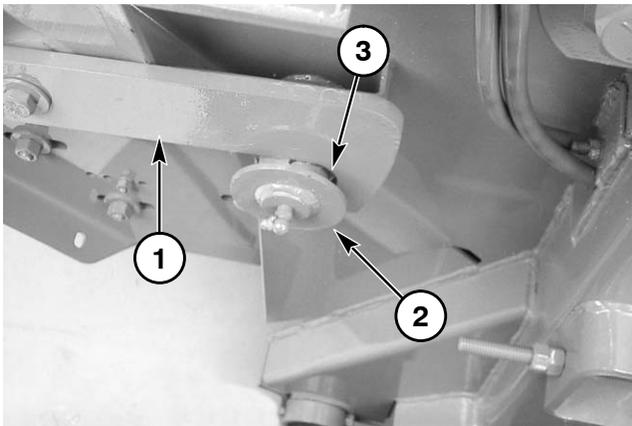

1 - Gate latch  
2 - Latch pin  
3 - 1/8 - 3/16" (3.2 - 4.8 mm) clearance

Fig. 62

### Gate End Roller (Fig. 63)

The gate end roller can be adjusted by means of the three 1/2" bolts and one 5/16" bolt on each side of the gate. The 1/2" bolts are installed in slots and the 5/16" bolt can be positioned in any one of a series of holes to vary the position of the roller. The roller should be adjusted and maintained at a position of 3/4 to 1-1/4" (19-32 mm) from the 16" (406 mm) lower drive roller. However, this distance must be increased to 1-1/4 to 1-3/4" (32-44 mm) for balers equipped with the Quick Wrap attachment.

**NOTE:** The tailgate **MUST** be tight against the stops before making adjustment. (See Fig. 61.)

**IMPORTANT:** BE SURE that the roller is set to the same position on both sides of the gate, as determined by the 5/16" bolt pattern. Also, BE SURE that the right and left gate end roller support arms are kept parallel to each other to insure proper belt tracking.

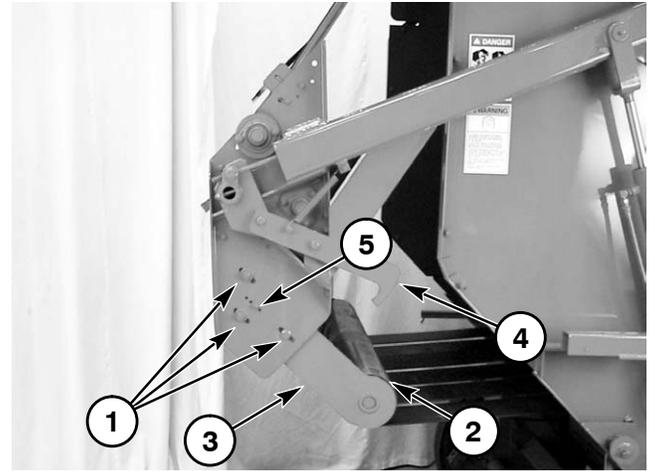

1 - 1/2" gate end roller adjustment bolts  
2 - End roller  
3 - Right support arm  
4 - Gate latch  
5 - 5/16" positioning bolt

Fig. 63

### Pivoting Power In-feed Roll Spring (Fig. 64)

The purpose of the pivoting power in-feed roller is to compress the material which is entering between it and the lower fixed power in-feed roller. The pivoting roller is spring-loaded and gear driven from the right side of the machine. The pivoting in-feed roller tension spring length should be set to 19.5" (495 mm). For lighter, shorter crops, the spring tension can be reduced.

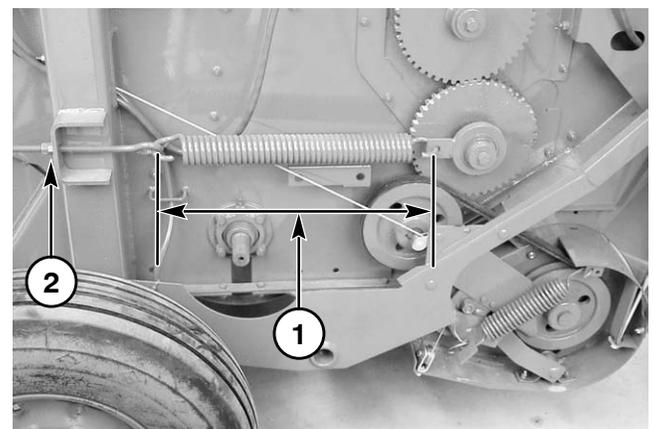

1 - 19.5" (495 mm) inside hook to inside hook  
2 - Adjustment bolt with two nuts to lock

Fig. 64

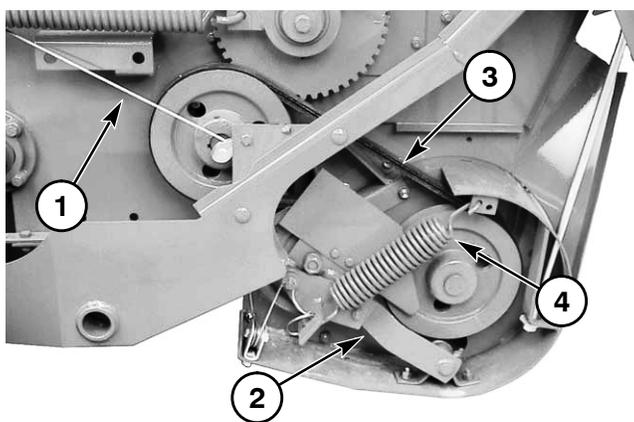

- 1 - Overfill clutch cable
- 2 - Idler arm
- 3 - Pickup drive V-belt
- 4 - Pickup drive tension spring

**Fig. 65**

## Pickup Height

### A: 2480 and 2780 (Fig. 66)

The baler pickup should be run as high off the ground as possible while still being able to completely pick up all of the crop. A lever and stop pin is provided to raise and lower the pickup. The pickup height can also be adjusted by repositioning the lift rods into a different hole location. This adjustment may be required if the hitch tongue has been positioned in the extreme high or low position. BE SURE to adjust the pickup to the same height on each side.

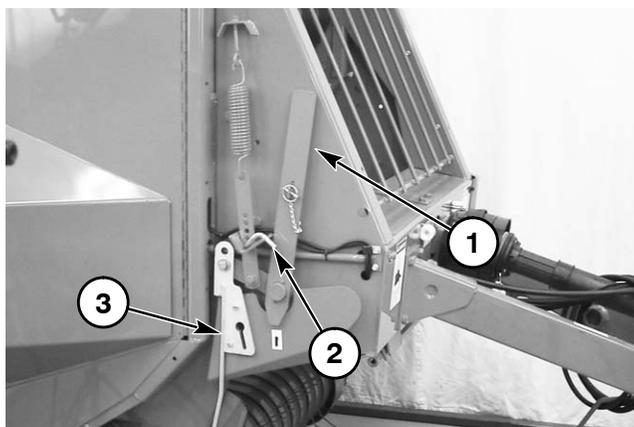

- 1 - Pickup lift hand lever
- 2 - Stop pin
- 3 - Lift rod

**Fig. 66**

### B: 2580, 2680 and 2880 (Fig. 67)

The baler pickup should be run as high off the ground as possible while still being able to completely pick up all of the crop. A hand crank is provided to raise and lower

the pickup. The pickup is raised by turning the hand crank in a clockwise direction and lowered by turning the hand crank in a counterclockwise direction.

If an optional hydraulic lift kit is installed, the lower limit of the pickup is controlled by the hand crank. To set height, lower the hand crank and hydraulic lift cylinder all the way. Set ground clearance with the manual hand crank to the desired height. Pickup can now be operated with the hydraulic lift.

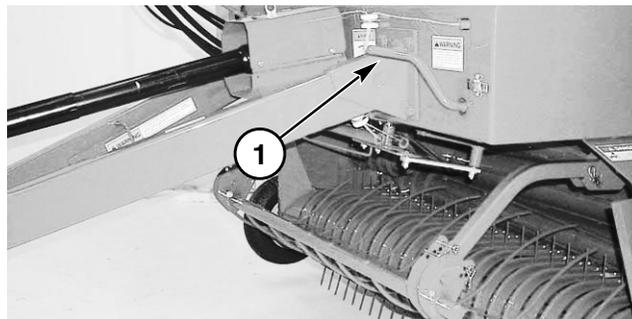

- 1 - Pickup lift hand crank

**Fig. 67: 2580, 2680 and 2880**

## Pickup Flotation Spring

### A: 2480 and 2780 (Fig. 68)

The pickup flotation spring is located on the front right side of the baler. The flotation is set at the factory for a baler not equipped with crowder wheels. The extension spring should be stretched to 11" (280 mm) hook to hook when the pickup is in the "up" position.

If crowder wheels are added to the baler, it will be necessary to increase the spring tension to achieve the desired pickup flotation.

### B: 2580, 2680 and 2880 (Fig. 69)

The pickup flotation spring for standard width pickup is located on the left side of the baler just below the TDC cylinder. The flotation is set at the factory for a baler not equipped with crowder wheels. The extension spring should be stretched to 9-1/2" (241 mm) hook to hook when the pickup is in the "up" position.

If crowder wheels and/or pickup gauge wheels are added to the baler, it will be necessary to increase the spring tension to achieve the desired pickup flotation.

### C: Wide Clean-Sweep Pickup (Fig. 70)

Two flotation springs are located behind the pickup on wide clean-sweep pickups built after 2001 model year. The extension spring should be adjusted to have some tension on it when the pickup is in the "up" position.

## Pickup Drive

### A: 2480 and 2780 (Fig. 65)

The pickup is driven by a V-belt from the lower fixed power in-feed roller. The belt drive will slip in the event of an overload. Spring tension on the idler can be changed by repositioning the spring hooks and adjusting the bracket on the lower back end of the spring.

**NOTE:** *V-belt wear and stretching should be checked periodically to avoid affecting overfill clutch mechanism operation.*

### B: 2580, 2680 and 2880

The pickup is driven by ratchet clutch device. No adjustments are needed.

## Overfill Clutch

### A: 2480 and 2780 (Fig. 65)

The overfill clutch mechanism is linked to the pickup drive and serves to protect the baler if it becomes filled beyond design capacity. Readjustment of the clutch mechanism may be required due to stretching of the V-belt or overfill clutch linkage cable. To make the adjustment, first make sure the pickup is set to its operating height. Then, loosen the 3/8" hexagon nut that clamps the cable to the pickup V-belt idler arm. Pull on the cable until the idler moves and backs off slightly and then retighten the nut.

Check to see if the overfill clutch linkage cable is too loose by pulling down on the cable at the upper rear of the baler. The cable, when pulled down, should deflect downward less than 2" (51 mm) from the frame channel before the pickup V-belt idler has started to move away from the V-belt. If deflection is more than 2" (51 mm), readjust cable clamping point. Cable tension should be checked on a routine basis every 50 hours (or weekly) of operation.

**IMPORTANT:** *Excessive cable tension will mean inadequate V-belt tension and result in excessive V-belt wear and pickup slippage. Too little cable tension will cause the overfill clutch to malfunction and thus NOT protect the baler. Carefully observe the forming of the first bale made after the overfill clutch mechanism is adjusted, to ensure that the mechanism is functioning properly.*

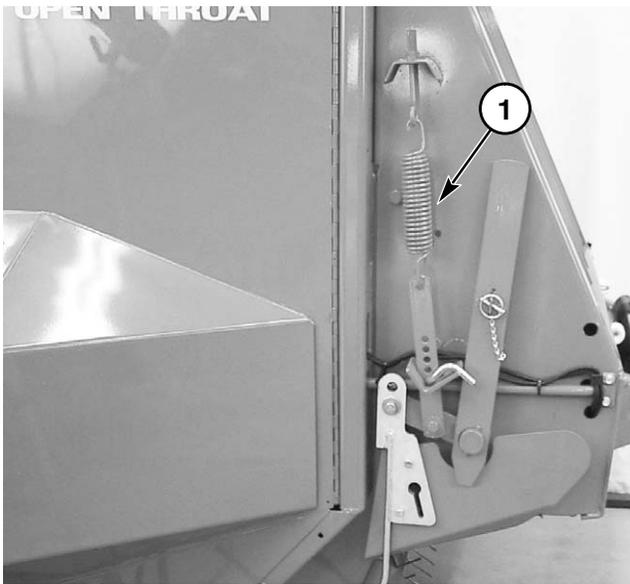

1 - Pickup flotation spring  
Fig. 68: 2480 & 2780

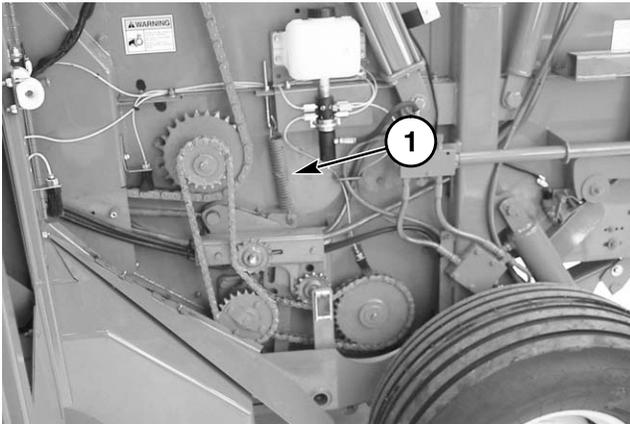

1 - Pickup flotation spring  
Fig. 69: 2580, 2680 & 2880 Standard  
Width Pickup

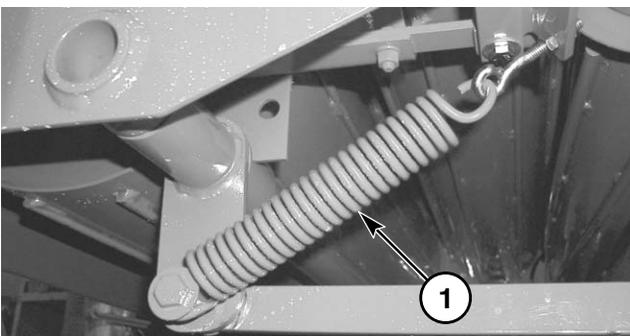

1 - Flotation spring  
Fig. 70: Wide Clean-Sweep Pickup

## Crowder Wheels

The crowder wheels are designed to float and engage the ground when the pickup is in the operating position. When operating, the main pushbar should be free of the transport arms located on each side of the pickup. If not, adjust and position the pickup arms to give the crowder wheels room to travel, but still be lifted by the pickup when the pickup is raised to the transport position. The crowder wheels should float with about 15 pounds (67 N) of downward force when measured at the wheel. The crowder wheel can be moved inward or outward to suit different crop conditions. Remove and retain the four bolts on the end of each pushbar and position the wheels to the desired location. Secure with retained hardware.

## Pickup Gauge Wheels

Keep tires inflated to 40 PSI (276 kPa). The pickup gauge wheels are to be positioned 1-1/2 to 2" (38 to 51 mm) off the ground when the pickup is in the operating position. By running at this height, the wheel will have less tendency to pin crop to the ground that is wrapped around the end of the pickup. The gauge wheel is adjusted on the end of the pickup by removing the 1/2" bolt that is located ahead of the main gauge wheel support tube. Remove the bolt and place it in the desired hole of the double flanged bracket to obtain the desired wheel height. Retighten bolt.

## Windguard (Fig. 71)

The windguard for the pickup has three adjustment points. The adjustment of the hanger arm is with a pin controlling the height of the pivot point of the windguard. The pin should be in the uppermost location for heavy or tall stubble crops. Lower positions are for lighter crops or windy conditions. There are also two wire lock pins limiting the windguard's upper and lower pivoting motion. Adjustments made to the windguard should be the same on each side.

Adjust windguard so the fingers are raised up and pointed at the bottom edge of the power feed roller for very light and fine crops.

The windguard may be quickly removed for ease of adjustment or unplugging by releasing the latches on either end.

---

# WARNING

**NEVER** operate the baler unless the windguard is in place and properly adjusted.

---

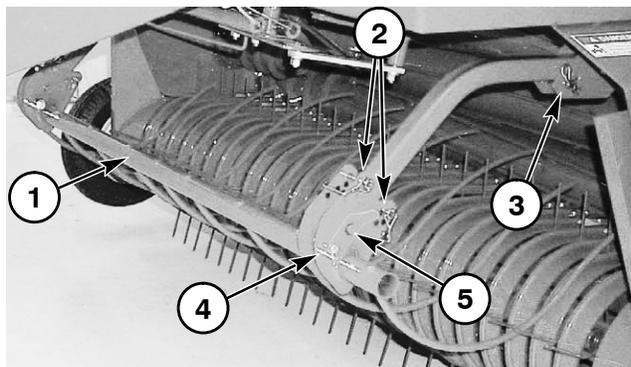

- 1 - Windguard
- 2 - Upstop/downstop wire lock pins
- 3 - Hanger arm height
- 4 - Wire lock pivot pins
- 5 - Windguard latch

Fig. 71

## Scrapers

### A: Stripper Roll and Pivoting Power Feed Roll (Fig. 72)

The stripper roll and the pivoting power feed roll are equipped with adjustable full-width scrapers to help prevent material build-up on the rollers. The scrapers **MUST** be set close to enable full-width cleaning. Access to the adjustment hardware is by way of raising the baler front guard assembly. Access to the scrapers is through the inside of the baler after using proper procedures for raising and locking the tailgate as discussed in the Operation chapter of this manual.

To adjust the scraper blades, loosen the five sets of 3/8" attaching hardware. Then tap each scraper into contact with a 0.015" (0.38 mm) piece of shim stock against the roller. Tighten the 3/8" retaining hardware.

The blades will wear and may require replacement after a period of extended baler use. Contact your Gehl dealer for the replacement blade part number.

**IMPORTANT:** *Inspect the scraper adjustment on a routine basis every 100 hours (or monthly) of*

operation. If the scraper is NOT adjusted correctly, material will build up on the rollers, inhibit core formation, and cause excessive horsepower requirements.

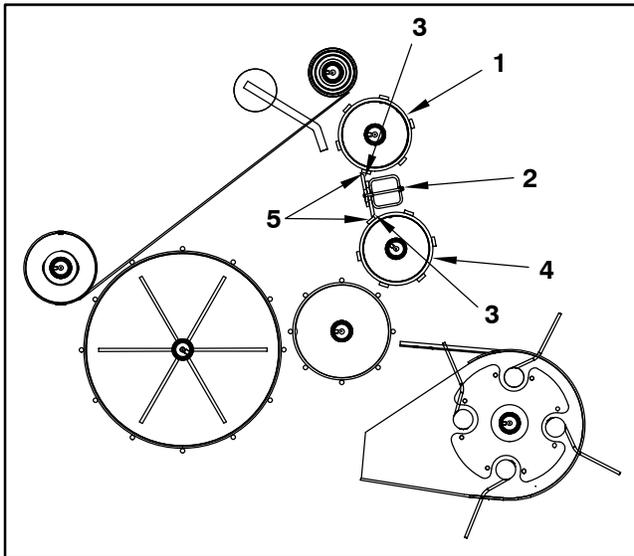

- 1 - Stripper roller
- 2 - 3/8" (9.5 mm) scraper blade attaching hardware
- 3 - Scrapers
- 4 - Pivoting power in-feed roller
- 5 - Measure 0.015" (0.38 mm) here

Fig. 72

### B: Wide Clean-Sweep Pickup (Figs. 73 & 74)

The wide clean-sweep pickup is equipped with five scrapers in three locations. The wide converging roller has a scraper across the back side of it and each of the small augers has its own scraper. All scrapers are adjusted the same.

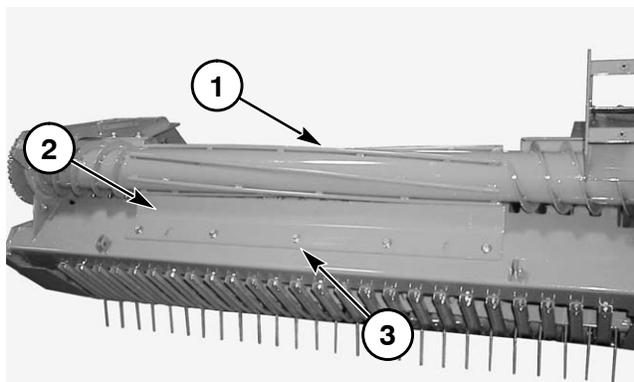

- 1 - Converging roller
- 2 - Scraper
- 3 - Scraper retaining hardware (five places)

Fig. 73: Viewed from Backside of Pickup,  
Pickup Removed from Baler for Clarity

To adjust the scraper blades, loosen the attaching hardware. Then tap each scraper into contact with a 0.015" (0.38 mm) piece of shim stock against the roller or auger. Tighten the retaining hardware. Be sure that the scrapers are not coming in contact with the roller or auger flighting.

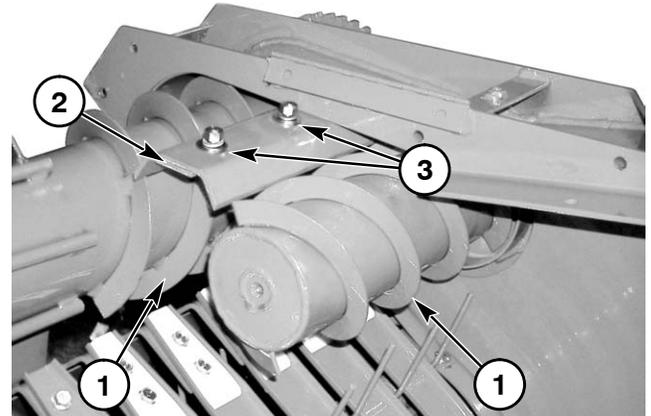

- 1 - Augers (two each side)
- 2 - Scrapers (two each side)
- 3 - Scraper retaining hardware

Fig. 74: Left Side of Wide Pickup, Pickup  
Removed from Baler for clarity

The blades will wear and may require replacement after a period of extended baler use. Contact your Gehl dealer for the replacement blade part number.

**IMPORTANT:** *Inspect the scraper adjustment on a routine basis every 50 hours (or weekly) of operation. If the scraper is NOT adjusted correctly, material will build up on the rollers and cause excessive horsepower requirements.*

### Shuttle Stops (Fig. 75)

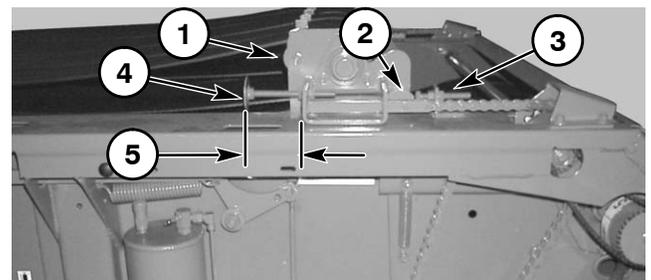

- 1 - Belt shuttle
- 2 - Shuttle lock
- 3 - Right side shuttle stop adjustment bolt  
(one each side)
- 4 - Overfill trip bolt
- 5 - Trip bolt length adjustment

Fig. 75: Shuttle Lock in  
"Engaged" Position

In certain short or very dry straws or grass conditions, bale starting may be improved by slackening the belts

## Chapter 6 - Care & Maintenance (Adjustments)

during the core formation stage. The shuttle stops are provided to enable slackening the belts, when required. Adjust the shuttle stop bolt on each end of the shuttle assembly equally to move the shuttle rearward. 1" (25 mm) of rearward shuttle movement results in approximately 4" (102 mm) of slack in the belts.

### Overfill Clutch Trip Bolt (Fig. 75)

If equipped, the settings for the overfill clutch trip bolt is measured from the edge of the washer to the backside of the shuttle channel. The measurement for the 2480 and 2780 balers is 3.5" (89 mm).

**IMPORTANT:** *DO NOT set the bolt length so short that the shuttle contacts the top rear rolls. Damage to the shuttle and rolls will result.*

### Squaring Belt Shuttle (Fig. 76)

It is essential that the belt shuttle be square with the baler frame and the belt tracking roller be properly adjusted (see topic titled "Belt Tracking & Alignment") so that the belts track evenly. To check for shuttle squareness, measure from a crossmember on the top front of the baler to the right and left end of one of the shuttle roller tubes. Count the number of chain links between the shuttle and the sprocket. The number of links should be the same for both sides. To square the belt shuttle, have the baler empty and the rear gate closed. Adjust squareness with the bolt on the left end of the shuttle. If the adjustment bolt will NOT square the belt shuttle, it will be necessary to change the index position of the keyed sprockets that connect the left and right density cylinder loading chains. Use the following procedure for adjustment:

1. Determine the direction in which the cylinder loading chain needs to be adjusted. Remember that the two sprockets for the chain tension are keyed to a common shaft.

2. Depressurize the TDC system. Fully loosen or remove the valve stem located on top of the reservoir. **DO NOT** retighten until ready to pressurize.
3. Remove the trip spacer from the cylinder trip arm. This is done to prevent accidental actuation of the valve trip mechanism (covered later in this chapter).

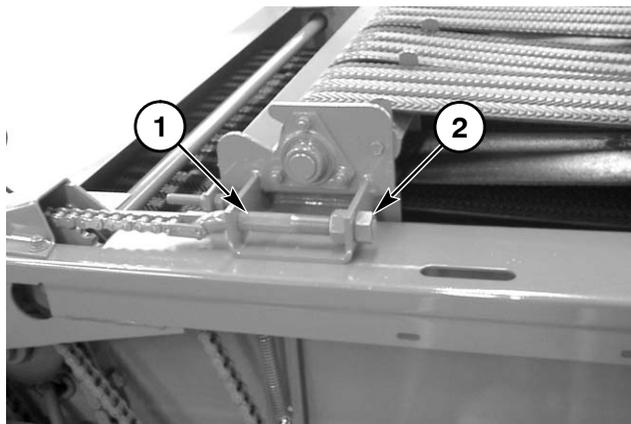

- 1 - Adjustment bolt for squaring shuttle
- 2 - Adjustment lock nuts

**Fig. 76**

4. Advance the No. 60 cylinder loading chain the necessary amount and re-adjust bolt to square shuttle.
5. Replace and/or tighten valve stem and pressurize to 170 PSI (1172 kPa).
6. Adjust shuttle squareness with adjustment bolt.
7. Replace the trip spacer on the trip arm. Check to make sure that it will contact the spring loaded valve trip mechanism when baling resumes.

## Twine Tie System

### A: Left Hand Twine Placement (Fig. 77)

To adjust end-wrap twine placement on the left hand side of the baler:

1. Extend the actuator until the twine arm approaches the left side.
2. Loosen the jam nut on the stop bolt located on the left side of the twine tie frame assembly.
3. Extend the stop bolt to stop the twine arm closer to the center of the bale and retract the stop bolt to allow the twine arm to travel closer to the left side of the bale.
4. Secure the adjustment by tightening the jam nut.
5. Electrically power the twine arm against the stop bolt on the left side of the baler to verify that the twine jaws will latch in the open position.

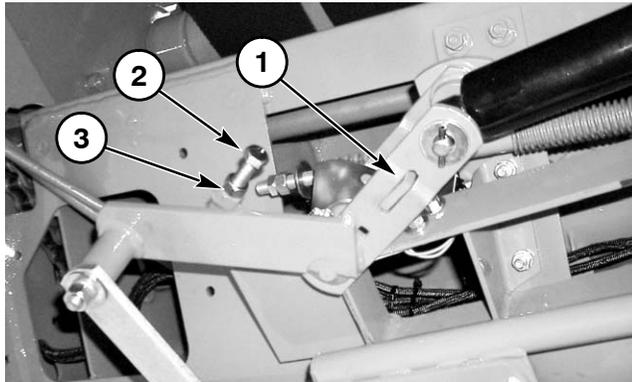

- 1 - Stop plate
- 2 - Stop bolt
- 3 - Jam nut

Fig. 77: Viewed from Bottom of Baler  
(For later models, See Fig. 87)

### B: Right Hand End Wrap Twine Placement Adjustment (Auto Twine and Auto Bale Control models only) (Figs. 78, 79 & 80)

To adjust the placement of the right hand end wraps:

1. Manually swing the twine arm to the desired position for placing wraps on the bale.
2. Loosen the 5/16" hex nut and carriage bolt which secures the cam/pause plate to the bottom of the actuator arm assembly.

**NOTE:** When looking up at the end wrap cam/pause plate from the bottom of the baler, move the plate counterclockwise to place twine closer to the edge of the bale or clockwise to place twine further

inward from edge of bale. The factory sets the leading edge of the plate from the actuator arm (set plate according to Fig. 79. Ref. 6). This setting will place the twine at approximately 4" (102 mm) from the edge of the bale).

3. Rotate the cam/pause plate so that the plate passes between the magnet and switch.
4. Tighten the 5/16" hex nut.

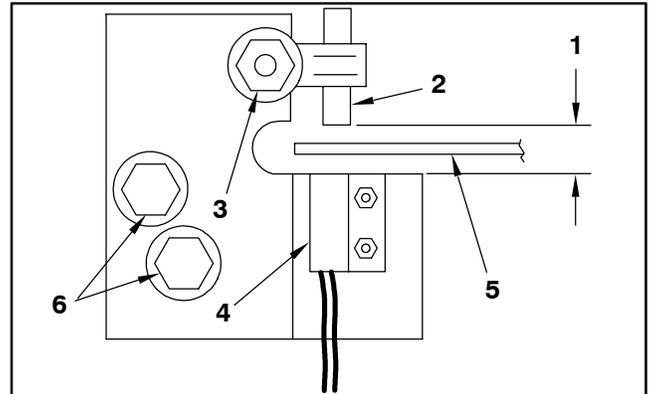

- 1 - 1/8 to 3/16" (3.2 to 4.8 mm) clearance
- 2 - Magnet
- 3 - Hex nut
- 4 - Switch
- 5 - Cam/pause plate
- 6 - 5/16" cap screws, plain washers and hex nuts

Fig. 78: End Wrap Pause Switch Magnet Adjustment

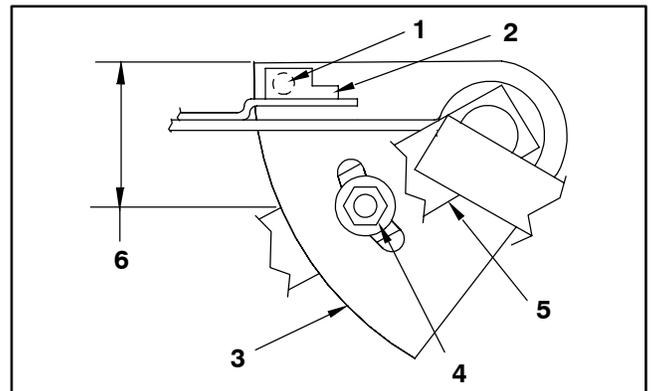

- 1 - Magnet
- 2 - Switch
- 3 - Cam/pause plate (move counterclockwise to place twine closer to edge of bale)
- 4 - 5/16" carriage bolt, plain washer and hex nut
- 5 - Actuator arm assembly
- 6 - Factory settings:
  - 2.5" (64 mm) - older style twine tie
  - 2.25" (57 mm) - newer chain drive w/Dixson
  - 2.0" (51 mm) - newer chain drive w/RDS

Fig. 79: Cam/Pause Plate Position Adjustment (As Viewed Looking Up from Bottom of Baler)

**C: Twine Tail Length (Fig. 80)**

To change the length of the twine tails, adjust the jam nuts on the end of the spring slide rod. Loosening the adjustment delays the opening of the twine jaws and lengthens the tails. Tightening the adjustment advances the opening of the twine jaws and shortens the tails.

It is possible that lengthening the twine tails too much could prevent the twine jaws from being latched open when the twine arm moves to the left side of the baler. Electrically power the twine arm against the stop bolt on the left side of the baler to verify that the twine jaws will latch in the open position.

**NOTE:** *It is possible to loosen the jam nuts so far that the clamp jaws will not clamp twine. Verify clamp jaw operation before resuming baling.*

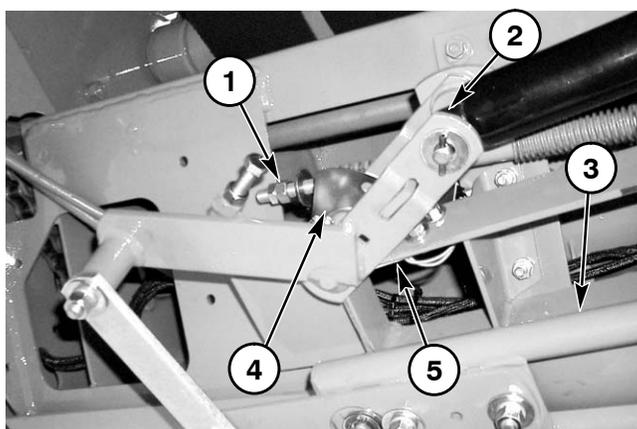

- 1 - Jam nuts on end of spring slide rod
- 2 - Actuator fully retracted
- 3 - Twine arm
- 4 - End wrap pause switch trip bracket  
(Auto Twine & Bale Control models only)
- 5 - End wrap pause switch assembly  
(Auto Twine & Bale Control models only)

**Fig. 80: Viewed from Bottom of Baler**

**D: Twine Tension (Fig. 81)**

On all balers, twine tension is controlled on the twine arm with a spring-loaded plate. Twine is routed under the plate and between the adjusting screws. Tightening the spring-loaded screws increases tension on the twine and loosening the screws decreases tension on the twine.

**NOTE:** *If tension is too high, this could result in twine not starting onto bale. If twine does not start when feeding crop in, loosen tension screws.*

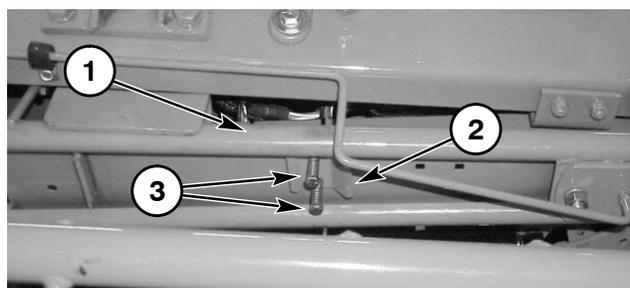

- 1 - Twine arm
- 2 - Tension plate
- 3 - Tension adjustment screws

**Fig. 81**

**E: Twine Jaws (Figs. 82, 83 & 84)**

**1: Latch Position**

To properly adjust the clamp jaw latch position:

5. Fully extend the actuator. Then, adjust the spring slide rod so the twine jaw pivot rod rotates below the catch on the trip assembly. When this position is obtained, tighten the jam nuts.

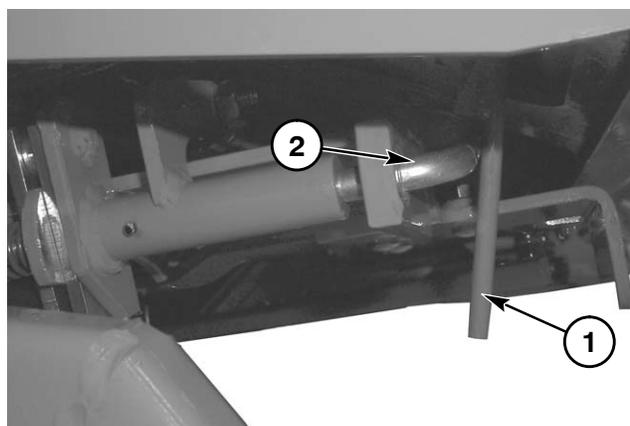

- 1 - Catch rod
- 2 - Twine jaw pivot rod

**Fig. 82**

**2: Latch Tension**

To adjust the twine jaw latch tension:

6. Rotate the lock nut on the clamp jaw pivot rod. The tighter the spring is compressed, the greater the tension on the twine. Adjust the spring to a length of 1-1/2" (38 mm). For thicker twine, the spring tension may need to be loosened to allow the twine jaws to close completely.

**NOTE:** *It may be desirable to install twine jaws with the flat edge up if problems occur using plastic twine. See Figure 83.*

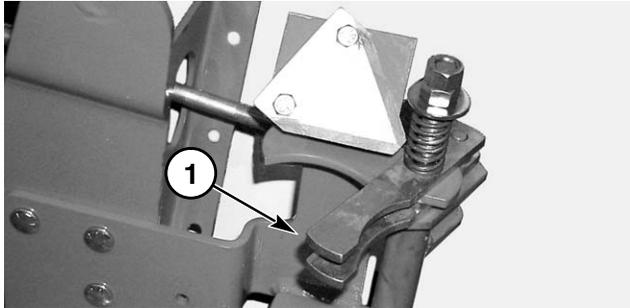

1 - Twine jaws reversed for plastic twine  
Fig. 83

### 3: Manually Opening Twine Jaws (Fig. 84)

At times, it may be necessary to open the twine jaws to insert or clear the twine. To open the jaws, place a 3/4" (19 mm) box or open end wrench on the two 1/2" jam nuts on the twine jaw pivot rod and turn.

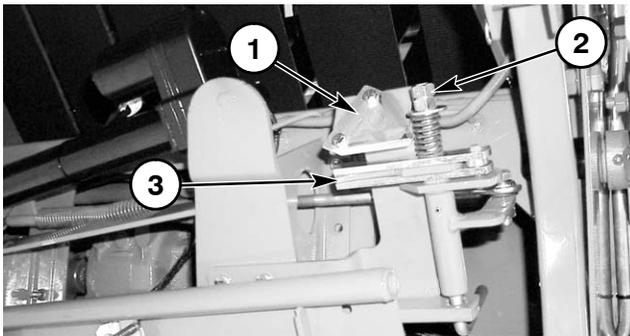

1 - Twine knife  
2 - Lock nuts on end of clamp jaw pivot rod  
3 - Clamp jaw in closed position

Fig. 84

## Additional Adjustments for New Style Chain Drive Twine Tie

### A: Chain Adjustment (Fig. 85)

It may be necessary to tighten the drive chain for the twine tie periodically. To adjust, first extend the electric actuator with baler control. Then, loosen the 3/8" (9.5 mm) carriage bolt and slide the chain idler into the chain.

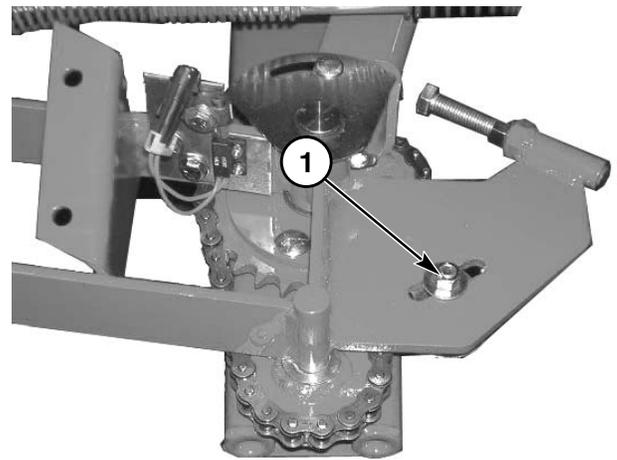

1 - 3/8" carriage bolt (chain tightener)  
Fig. 85

### B: Twine Arm Timing (Figs. 86 & 87)

It may be necessary to adjust the timing of the twine arm to the actuator. This may need to be done to ensure that the twine arm trips the twine jaws shut to cut the twine before the actuator fully retracts. Before adjusting the timing, tighten the drive chain. To adjust the timing, manually run the twine arm out from "home" position about 3 inches (76 mm) by using the baler control. Loosen the three 3/8" carriage bolts on the driver sprocket. Move the twine arm to "home" position (by hand, not by moving actuator) and tighten the bolts. Retract the actuator with the control. (There should be about 0.06" to 0.125" (1.5 to 3.2 mm) of actuator rod exposed when the twine arm is firmly "home"). If the twine arm cannot be adjusted all the way to "home" position with the actuator slightly extended, the slots for the timing bolts may not be long enough. If so, the chain will have to be removed and reinstalled after moving the driver sprocket one tooth on the chain.

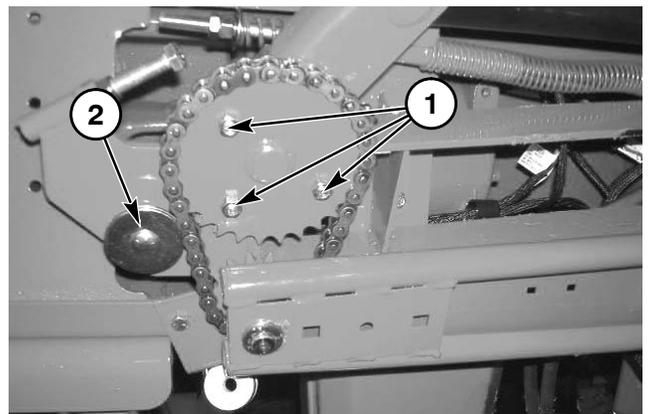

1 - Timing adjustment bolts (3)  
2 - Chain idler

Fig. 86

## Chapter 6 - Care & Maintenance (Adjustments)

The base end of the actuator is mounted by a bolt on the anchor assembly. This anchor assembly has two positions by using two sets of mounting holes. The set of holes labeled "R" is used for RDS auto twine control and for manual control systems. The set of holes labeled "D" is used for the Dixon auto bale control system.

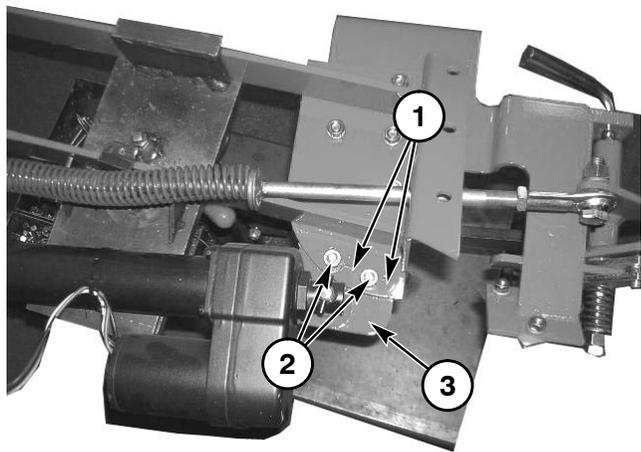

- 1 - Holes labeled "D" for Dixon
- 2 - Holes labeled "R" for RDS & manual controls
- 3 - Anchor Assembly

Fig. 87

## Bale Forming Belts

### A: Break-in Period

When the baler was assembled, the belts were tracked and set at the factory. The first 50 to 100 bales are an important break-in time for the belts. It is during this time that the belts will work in. Make every effort during this period to build even bales, thereby loading all the belts evenly.

### B: Causes for Mis-tracking

Belt tracking and alignment adjustments should be done while the baler is empty. If the belts mis-track while building a bale, it is usually caused by an unevenly built bale. The belts always track to the side of the baler with less hay in it. Adding hay to the small side of the bale will bring the belts back to their normal tracking position.

If one belt has a tendency to track or stray away from the others, it may be that the belt is damaged or is not the proper length. The belts should always be within 2-1/2" (64 mm) of each other in length for best tracking.

If all or several of the belts mis-track, look for probable causes before adjusting tracking. Possible causes could include a buildup of material on the rollers, a bent roller, a failed bearing, misaligned tailgate roller or an out-of-square shuttle.

### C: Belt Tracking & Alignment (Fig. 88)

1. Be sure the baler is empty and the tailgate is closed and latched. The shuttle should have returned to the "home" position and should be positioned squarely in the baler. (See the "Squaring the Belt Shuttle" topic in this chapter.) Exercise the MANDATORY SAFETY SHUTDOWN PROCEDURE (page 8), but do not disconnect the drive-line. Loosen the hardware on the belt tracking roller of the tailgate to the point where the roller will stay in position but can be adjusted with a block of wood and a hammer
2. Adjust one end of the tracking roller about 1/4" (6 mm) to move the path of the belts as needed. Lowering the right end of the roller will cause the belts to track to the left. Lowering (or raising) the left end of the roller will have the opposite effect as moving the right end.
3. Run the baler approximately three revolutions of the belts and then exercise the MANDATORY SAFETY SHUTDOWN PROCEDURE again. Observe the belt positions to determine if additional adjustment is necessary.



## WARNING

**Stay away from the baler when it is running. Contact with moving belts or other components can cause serious injury.**

---

4. Repeat steps 2 - 3 until the belts run straight without rubbing on the belt guides. When the belts are tracking properly, retighten the hardware on the tracking roller.

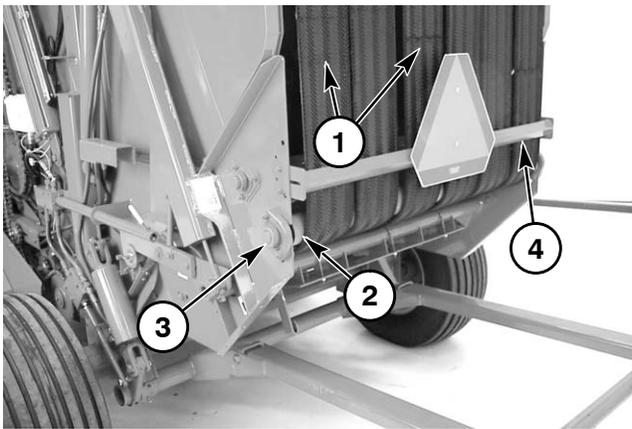

- 1 - Belts
- 2 - Belt tracking roller
- 3 - Adjust tracking roller here (each side)
- 4 - Tailgate belt guide

Fig. 88

- 5. Interchanging belt positions may improve belt tracking. This process, however, is more difficult, because it requires removing the belts from the baler in order to change belt positions.

**NOTE:** Improper bale formation may give an erroneous indication of faulty belt tracking. See "Bale Formation" topic in the Operation chapter for details.

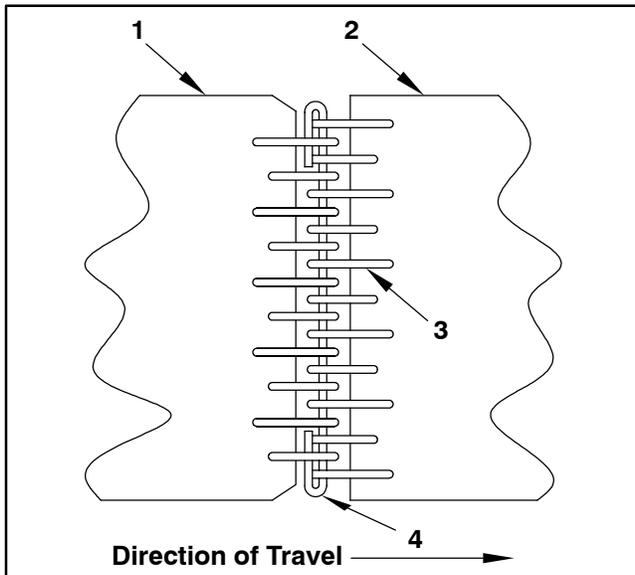

- 1 - Trailing end
- 2 - Leading end
- 3 - Outside lacing hook
- 4 - Lacing pin

Fig. 89: Belt Lacing on 2480 and 2780

**NOTE:** Whenever belt lacings are uncoupled, BE SURE to re-couple the belt so the end with extra hooks stays on the leading end as illustrated.

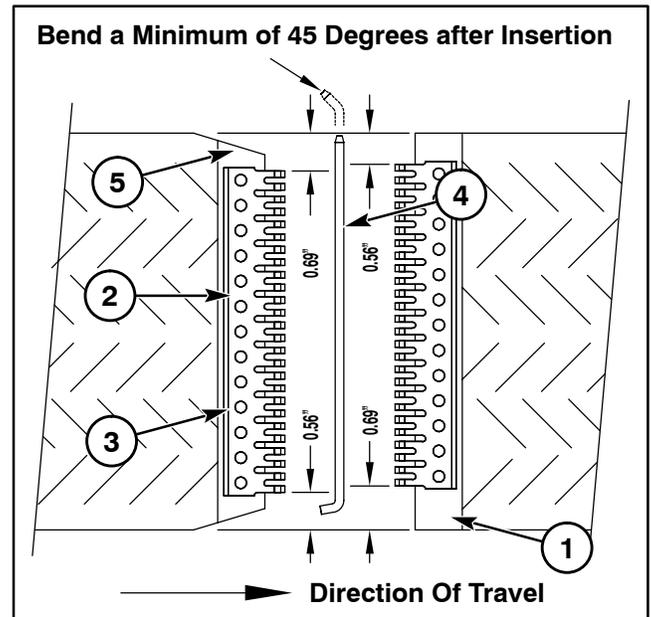

- 1 - Chevron ground off 3/4" (19 mm) for clearance
- 2 - Installed lacing
- 3 - Rivets (13 per hinge)
- 4 - Hardened pin
- 5 - Trailing corners trimmed

Fig. 90: Belt Lacing on 2580, 2680 and 2880

## **Bale Kicker (Fig. 91)**

### **A: Stop Valve Push Rod**

With bale kicker cylinder completely retracted, adjust the cap screw in the end of the push rod until it depresses the pin of stop valve within 0.06" (1.5 mm) of bottoming out. Using the slots in the guide plate, adjust the push rod so that the valve pin hits just above center on the hex bolt.

### **B: Bale Sensor Cam**

With the stop valve push rod properly adjusted, raise the bale sensor cam so that the flat area on the cam is just touching the bottom of the push rod. The slotted cam is properly adjusted when the slightest downward movement of the bale sensor arm causes the cam to begin to raise the push rod. When the push rod fails to contact the

stop valve (such as when a bale is present), the tailgate is prevented from closing.

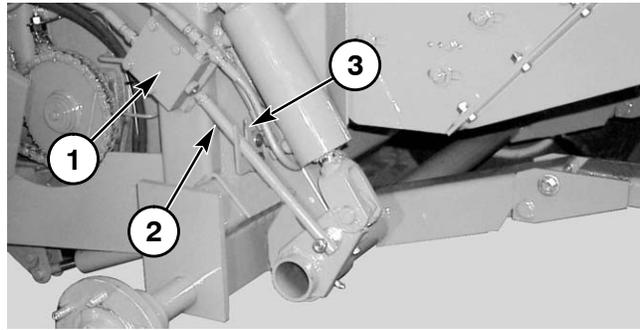

- 1 - Stop valve
- 2 - Push rod
- 3 - Push rod guide plate

**Fig. 91**

## LUBRICATION

### General Information

---



**NEVER lubricate the machine when any part of the unit is in motion. ALWAYS exercise the MANDATORY SAFETY SHUTDOWN PROCEDURE (page 8) BEFORE lubricating the machine.**

---

Remember that a sufficient amount of oil or grease will prevent excessive part wear and early failure.

**IMPORTANT:** *Whenever service is performed on hydraulic components (valves, cylinders, hoses, etc.) or transmission, care must be taken to prevent discharging fluid onto the ground. Catch and dispose of fluid per local waste disposal regulations.*

### Transmission Lubrication

The transmission should be checked after every 100 hours of operation and the oil level replenished as necessary. The transmission requires 1 quart (0.95 liters) of SAE 80W90 EP gear lube. Check the oil by removing the vent plug on top of the transmission. The dipstick is part of the vent plug. The oil level should leave a mark at the full line of the dipstick. If the oil level is below the full line, add oil through the top hole.

The transmission should be checked occasionally for oil drips and dust accumulation which indicates the seals are leaking. Oil which is tan in color and foams excessively indicates that it has water present and should be replaced.

The transmission oil is drained by removing the lower plug on the transmission. All plugs are located on the right side of the transmission and are accessed beneath the baler cross frame. Fill transmission with SAE 80W90 EP until oil appears at the proper mark on the dipstick. The dipstick is located on top of the transmission. Replace all plugs and dipstick.

**IMPORTANT:** *DO NOT overfill the transmission. Only fill to the full line on the dipstick.*

### TDC® Hydraulic System

When the density control cylinders are fully retracted, the fluid level in the reservoir sight tube should be between the two oil level marks. The TDC system comes filled from the factory with a special grade of hydraulic oil capable of operating at lower ambient temperatures than normal hydraulic oils. If low temperatures and slow shuttle returns are not a problem, ATF (Dexron II) is an acceptable oil to use in the TDC system. During the baling season, the fluid level should be checked before each day of operation (or at least every 10 hours) and replenished if the fluid drops below the lower oil level mark with the density cylinders fully retracted. Proper refilling procedures are described in the Service section of the Care & Maintenance chapter.

### Oiling

Lubricate all drive chains every 150 bales (or daily) of operation using a clean oil or a good grade of foaming aerosol lubricant. The recommended method is to spray the entire length of chain on the center of the rollers sufficiently to allow the chain sidebars to be thoroughly lubricated. It is better to lubricate chains when they are warm (after use, rather than before).

On balers equipped with an automatic chain oiler (standard on Silage Special balers), the oiler dispenses a measured amount of oil every time the tailgate is opened. The amount of oil used can be regulated with the adjusting screw at the base of the pump. Turning in the screw decreases the amount of oil dispensed, and turning out the screw out increases the amount of oil dispensed. Use only enough oil to keep the chains moist. A good starting point of adjustment is to have six threads of the adjustment screw showing below the locking nut. Lubrication is excessive if oil is dripping or being thrown off the chains. Be sure to use a good grade of clean petroleum oil (SAE 20W, 30W or 40W).

**NOTE:** *DO NOT use drain oil for chain oiling.*

Apply oil or foaming aerosol lubricant to the threads of the pickup height adjustment crank every 100 hours (or monthly).

It is a good practice to lubricate wear areas and pivot points. Apply oil or foaming aerosol lubricant on all bale starter pivot bushings at the end of each baling season and before storing baler. Best results are obtained if oil is applied at the end of day or when bushings are warm.

**IMPORTANT:** *Remove any stems or leaves that are wrapped around shafts next to bearings. Wrapped debris buildup can damage the bearing seals.*



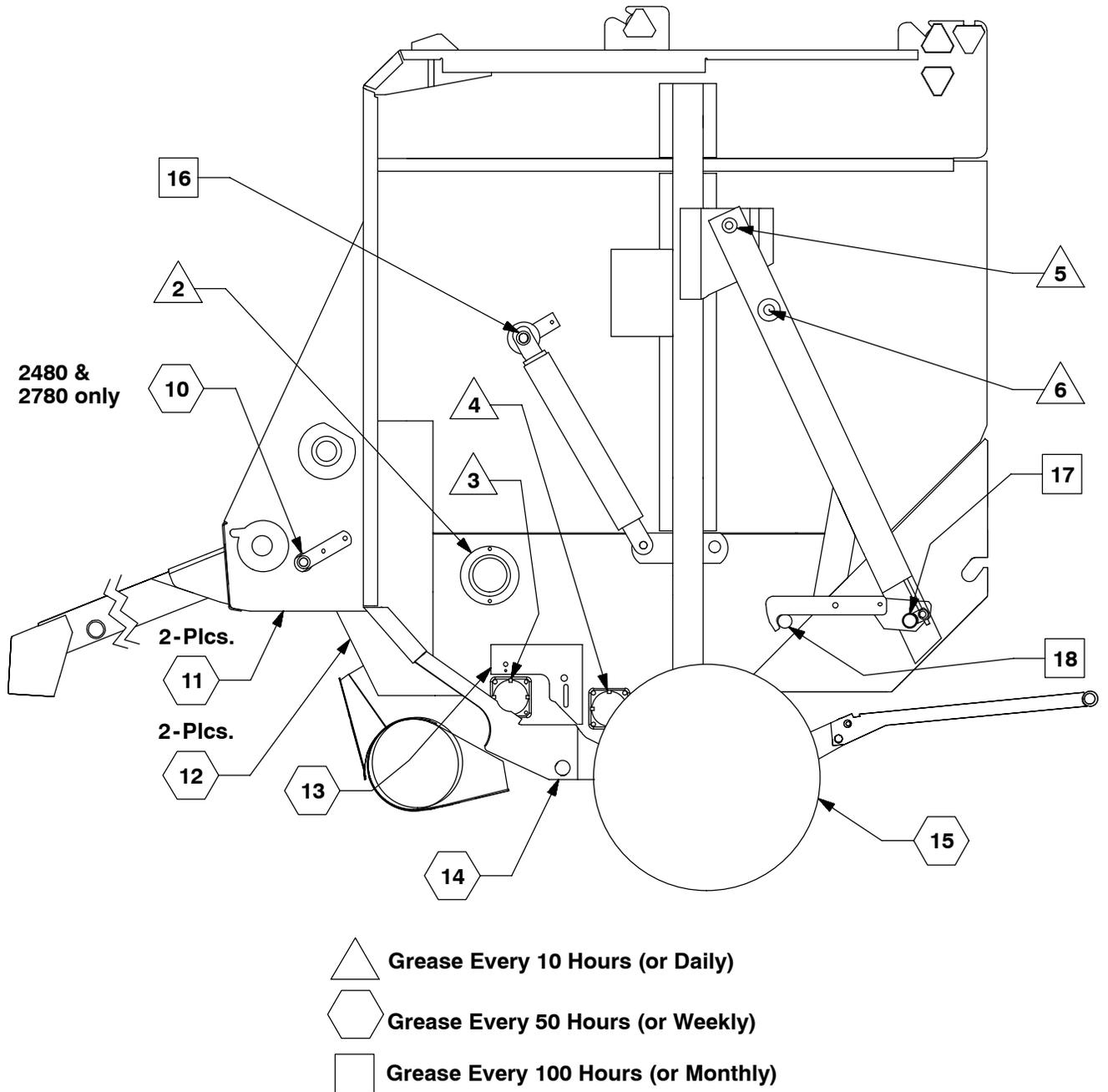

Fig. 93

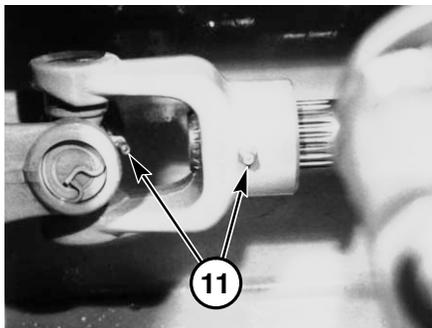

Fig. 94

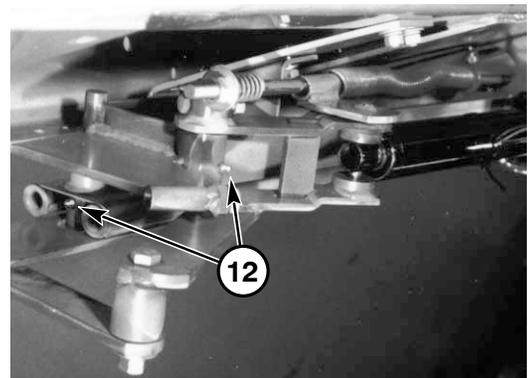

Fig. 95

**Chapter 6 - Care & Maintenance  
(Lubrication)**

The following is a listing of the grease fitting locations for the right side of the baler.

**Grease Fitting Locations - Right Side**

**A: Grease Every 10 Hours (or Daily)**

1. Gate Pivot Bushing
2. Gate Cylinder Pivot
3. Pickup Drive Ratchet Clutch  
(All Models Except 2480 and 2780)
4. Lower 16" (406 mm) Roller Bearing Housing

5. Lower 8" (203 mm) Roller Bearing Housing

**B: Grease Every 50 Hours (or Weekly)**

6. Kicker Pivot (Behind Tire) (Optional Accessory)
7. Pickup Pivot
8. Pickup Flotation Torsion Shaft Pivot

**C: Grease Every 100 Hours  
(or Monthly)**

9. Gate Latch Torsion Tube Pivot
10. Gate Latch Bearing
11. TDC Cylinder Idler Pivot

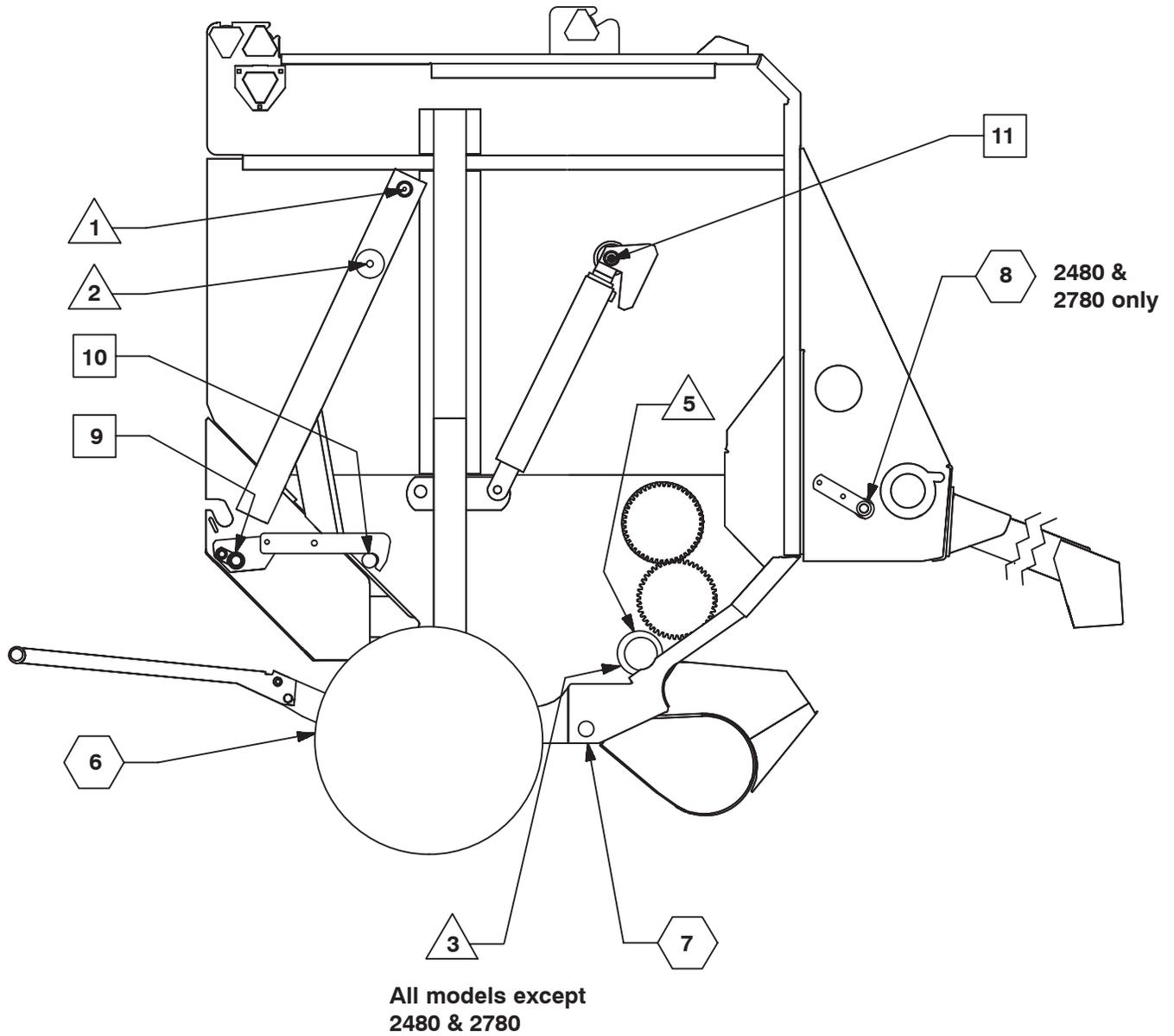

-  Grease every 10 hours (or daily)
-  Grease every 50 hours (or weekly)
-  Grease every 100 hours (or monthly)

Fig. 96

**Chapter 6 - Care & Maintenance  
(Lubrication)**

The following is a listing of the grease fitting locations for optional accessories that may be installed on the baler.

**Grease Fitting Locations - Optional Accessories**

**Grease Every 50 Hours (or Weekly)**

1. Bale Kicker Pivot Bushing (Each Side)
2. Crowder Wheel Pivot Bushing (Each Side)

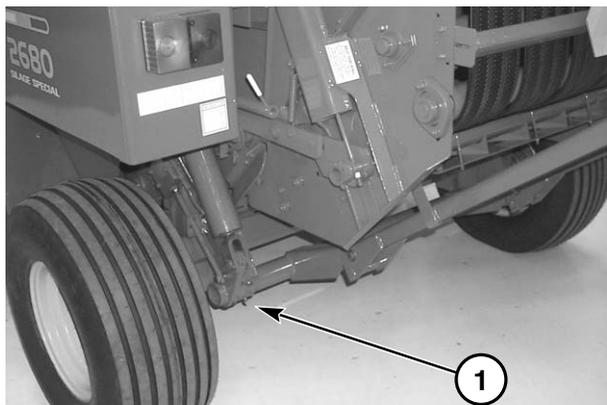

**Fig. 97**



**Fig. 98**

## SERVICE

# WARNING

**BEFORE** adjusting, lubricating or servicing this unit, exercise the **MANDATORY SAFETY SHUTDOWN PROCEDURE** (page 8).

**NOTE:** The following information is referred to in both the Troubleshooting Guide and the Maintenance Schedule chapters of this manual. It should also be understood that all services covered in this chapter are owner-operator responsibilities. Where indicated, certain service routines should only be carried out by an authorized Gehl dealer or Gehl Company representative.

### Sealed Ball Bearing Replacement (Fig. 99)

Sealed ball bearings are used on various shafts around the unit. This type of bearing is generally retained in place with a self-locking eccentric lock collar. The lock collar has a counter-bored recess, which is eccentric with the collar bore. This eccentric recess engages or mates with an eccentric end of the bearing inner ring, when the bearing is assembled on the shaft. The bearing is engaged, on the inner ring cam, by the collar. This assembly grips the shaft tightly with a positive binding action that increases with use. The collar set screw provides supplementary locking.

A bearing can be removed from the shaft by loosening the set screw and tapping on a punch which is placed in the drift pin hole, to loosen the collar. Install bearings with self-locking collars in the following manner:

1. Place the bearing and collar on the shaft with the cam surfaces next to each other. Tighten the bolts on the bearing retainers.
2. Mate the cam of the lock collar with the cam of the bearing inner ring.
3. Press the locking collar against the bearing wide inner ring and turn it, in the direction of shaft rotation, until it tightly engages. Tighten the collar further by tapping on a punch inserted in the drift pin hole.

**IMPORTANT:** Overtightening the collar will damage it.

4. Last, tighten the set screw in the locking collar.

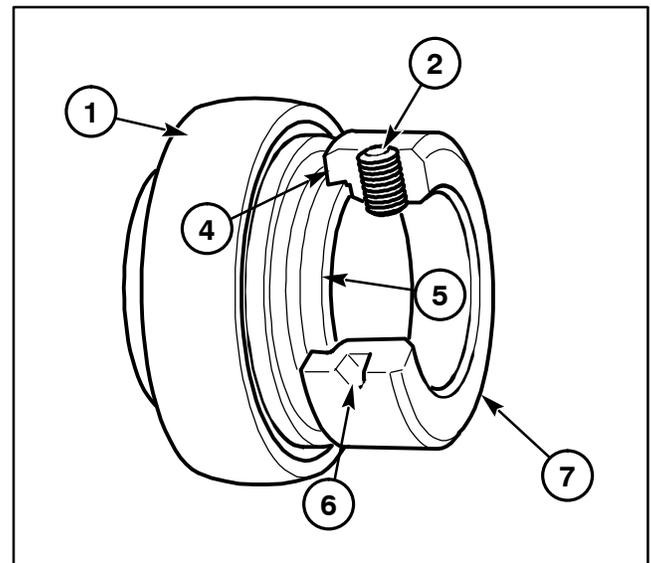

- 1 - Bearing
- 2 - Set screw
- 3 - Collar cam
- 4 - Wide inner cam ring
- 5 - Drift pin hole
- 6 - Eccentric self locking collar

Fig. 99

### Bale Size Indicator (Fig. 100)

The bale size indicator is driven by a chain attached to a small sprocket on the TDC chain sprocket on the right side of the baler. Should the indicator ever need repair, the indicator is calibrated by loosening the retaining bolt on the upper sprocket and rotating the sprocket until the indicator reads "0" with the baler empty. Tighten bolt when calibrated.

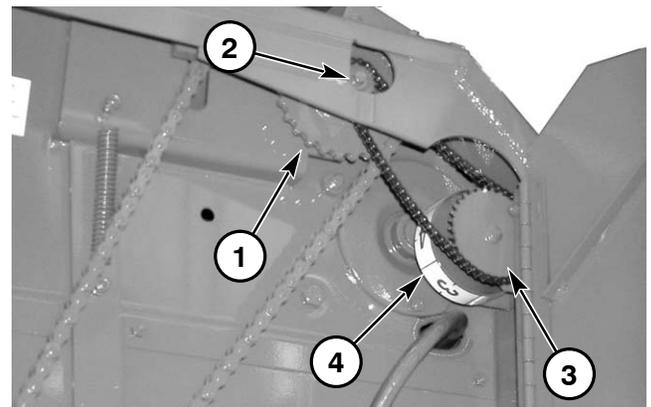

- 1 - TDC sprocket
- 2 - Indicator drive sprocket
- 3 - Indicator driven sprocket
- 4 - Back side of indicator

Fig. 100

## Gate Hydraulics (Figs. 101 & 102)

Refer to the hydraulic circuit diagrams provided for details on gate cylinder plumbing.

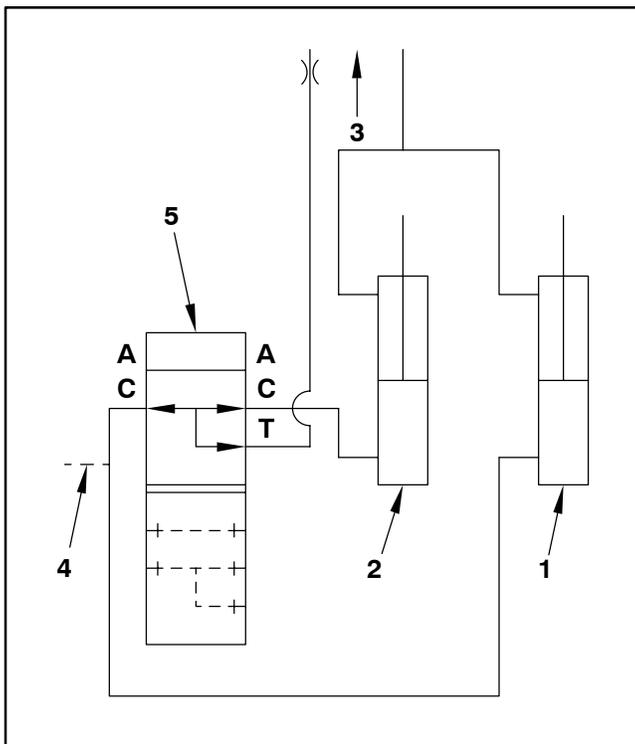

- 1 - Right gate cylinder
- 2 - Left gate cylinder
- 3 - To tractor hydraulics output
- 4 - To optional chain oiler
- 5 - Gate cylinder lock valve

Fig. 101: Baler without Optional Bale Kicker

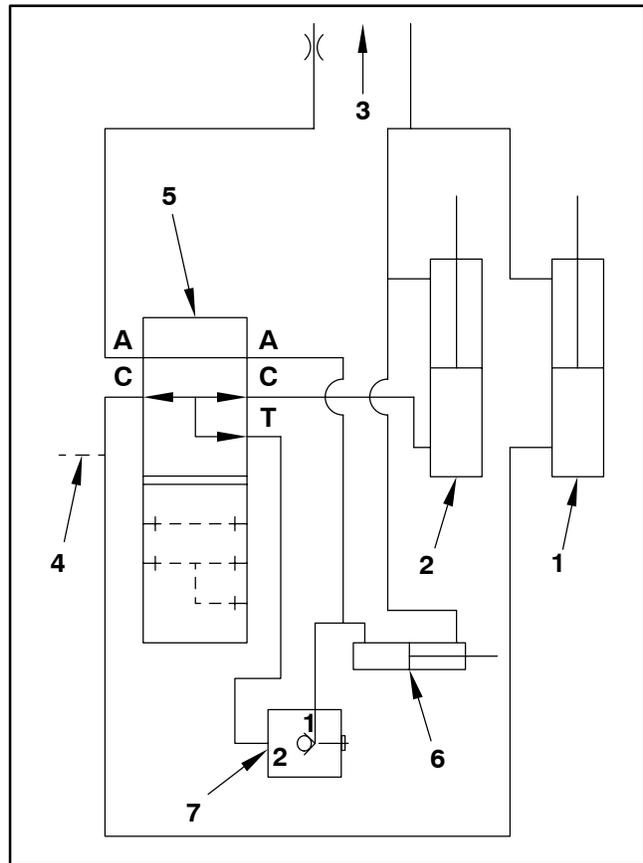

- 1 - Right gate cylinder
- 2 - Left gate cylinder
- 3 - To tractor hydraulics output
- 4 - To optional chain oiler
- 5 - Gate cylinder lock valve
- 6 - Bale kicker cylinder
- 7 - Bale kicker valve

Fig. 102: Baler with Optional Bale Kicker

## Pickup (Figs. 103 through 107)

The pickup should be inspected on a routine basis every 100 hours of operation. The following inspections should be made:

1. The cam follower bearings should be positioned 3/16-5/16" (4.8-7.9 mm) away from the inside edge of the cam track as shown.
2. Depending on conditions, the cam followers will wear out and need to be replaced. When replacing, it is recommended that the bolt (Gehl part number 066490) also be replaced. Apply Loctite® 609 or equivalent and torque the bolt to 75 lb.-ft. (102 Nm).



## WARNING

**NEVER** use your hands to search for hydraulic fluid leaks. Escaping fluid under pressure can be invisible and penetrate your skin causing serious injury! If any fluid is injected into your skin, see a doctor at once! Injected fluid **MUST** be surgically removed by a doctor familiar with this type of injury or gangrene may result.

**NOTE:** NO lock washer is used with the Gehl part number 066490 bolt.

- To check for cam wear and binding in the cam, remove the V-belt or chain which drives the pickup and turn the drive over by hand.

**NOTE:** Readjust any areas that are binding.

**NOTE:** It is not necessary to remove the pickup from the baler to replace the cam follower bearing. An access port is provided. See Fig. 106 for details.

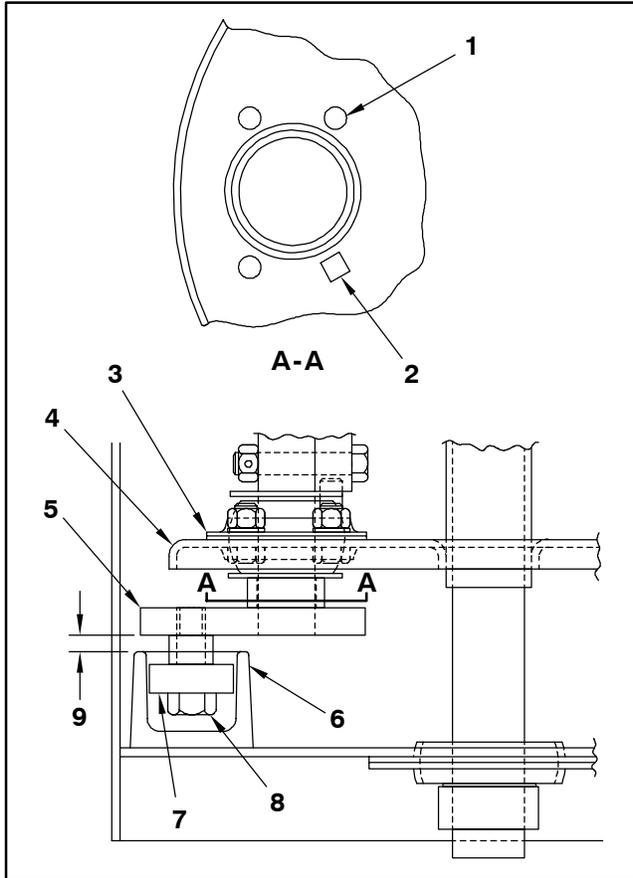

- Three holes for 3/8 x 3/4" cap screws
- Hole for 3/8 x 1-1/4" Grade 8 cap screws
- Retainer
- Reel
- Cam arm
- Cam
- Cam follower (520175)
- Cam bolt (066490)
- 1/16-1/8" (1.6-3.2 mm)

**Fig. 103: Cam Follower - 2480 and 2780**

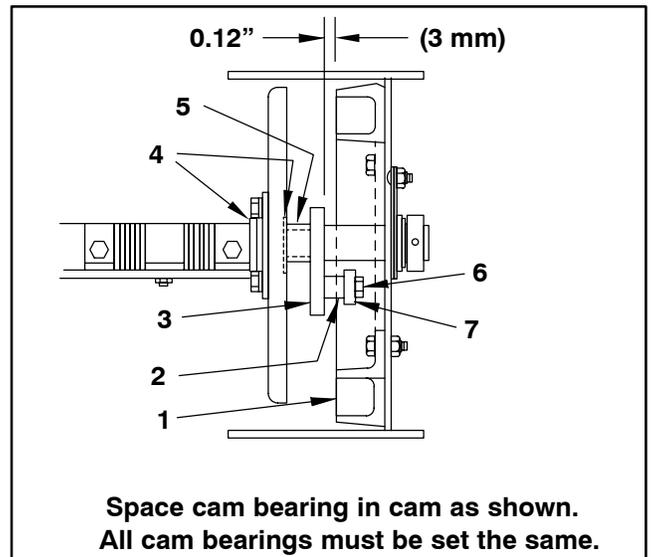

Space cam bearing in cam as shown.  
All cam bearings must be set the same.

- Cam
- Spacer
- Cam arm
- Washers
- Spacer
- Cap screw
- Cam bearing

**Fig. 104: Cam Follower - 2580, 2680 and 2880**

Cam followers must be checked on both ends on balers equipped with the wide pickup.

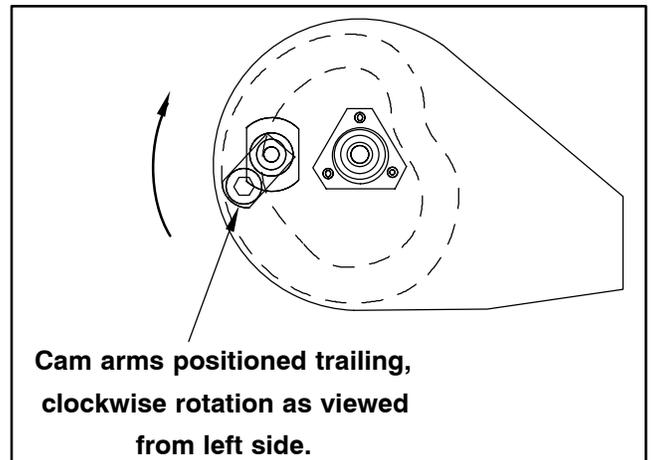

Cam arms positioned trailing,  
clockwise rotation as viewed  
from left side.

**Fig. 105**

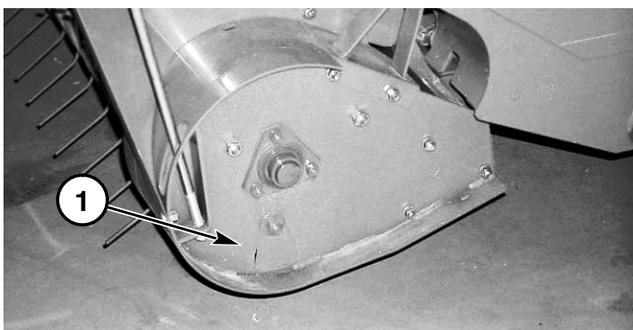

1 - Cam bearing access port

Fig. 106

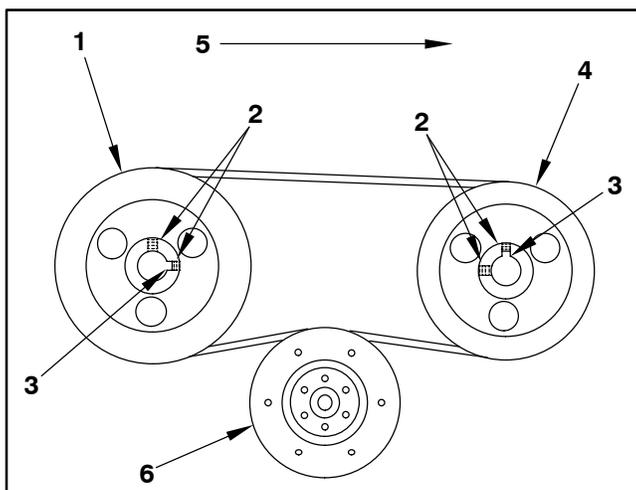

- 1 - Drive sheave
- 2 - Two set screws
- 3 - Keyway
- 4 - Driven sheave
- 5 - Front of pickup
- 6 - Idler

Fig. 107: Pickup Drive Belt  
(2480 and 2780)

4. On 2480 and 2780, inspect the sintered-metal bearings (four each side) located at the points where the tine bars pivot. Oil seals are provided on each side of the bearing.
5. BE SURE to check that the tine bar hardware is tightly secured.
6. Check for broken pickup tines. Best operation is only obtained after all broken tines have been replaced. On standard pickups, pickup tines can be ordered by Gehl part number 071607 (for the double tine) or 071939 (for the single tine). On the Clean Sweep pickups, pickup tines can be ordered

by Gehl part number 155594 (for the double tine) or 156133 (for the single tine).

On 2480 and 2780 balers, the pickup drive belt sheave has two set screw holes, and the driven sheave has two set screw holes. The hole over the keyway contains two set screws, one screw to lock the other, similar to jam nuts. Install the appropriate sheaves on their respective shafts as shown. See Figure 107.

## Total Density Control (TDC) System



## WARNING

**NEVER use your hands to search for hydraulic fluid leaks. Escaping fluid under pressure can be invisible and penetrate your skin causing serious injury! If any fluid is injected into your skin, see a doctor at once! Injected fluid MUST be surgically removed by a doctor familiar with this type of injury or gangrene may result.**

### A: Reservoir Air Pressure (Fig. 108)

The TDC system comes filled from the factory with a special grade of hydraulic oil capable of operating at lower ambient temperatures than normal hydraulic oils. If low temperatures and slow shuttle returns are not a problem, ATF (Dexron II) is an acceptable oil to use in the TDC system. The system is to be pressurized to 170 PSI (1172 kPa) by air pressure in the reservoir. The pressure is checked and adjusted **ONLY** when the density control cylinders are retracted (shuttle returned, baler empty). For normal operation, the reservoir pressure gauge **MUST** indicate a pressure reading of 170 PSI (1172 kPa). If the reading is not within this range, either add or bleed off air, as necessary, using the tank inlet and valve stem at the top of the reservoir.



## WARNING

**DO NOT pressurize the reservoir to more than 170 PSI (1172 kPa). NEVER pressurize with anything other than air or dry nitrogen, and only when shuttle is returned (baler is empty)!**

### C: Adding Fluid to Reservoir (Fig. 108)

To add fluid to the TDC system reservoir, proceed as follows:

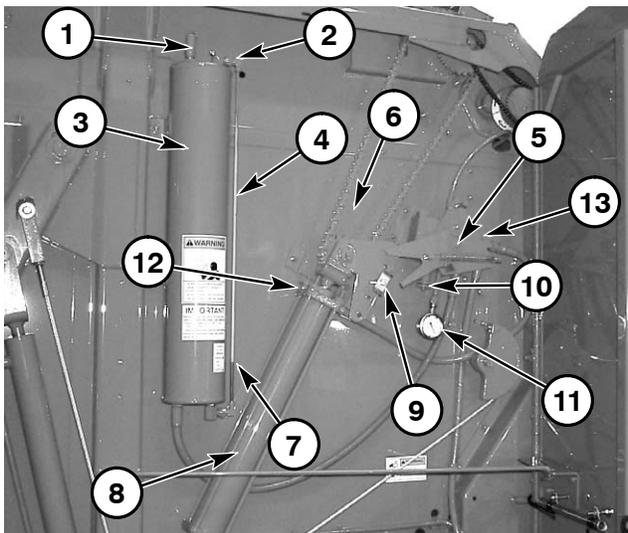

- 1 - Relief valve & adapter
- 2 - Tank inlet & valve system
- 3 - TDC reservoir
- 4 - Sight tube
- 5 - Valve trip mechanism
- 6 - Trip arm
- 7 - Oil level mark
- 8 - Density cylinder
- 9 - Trip spacer
- 10 - Adjustable relief valve
- 11 - Reservoir pressure gauge
- 12 - Density cylinder air bleed valve
- 13 - Hydraulic cap

Fig. 108

### B: Reservoir (Fig. 108)

The reservoir fluid level should be checked before each day of baler operation (or at 10-hour intervals) using the sight tube located on the forward side of the reservoir. Proper fluid level can be determined when both density cylinders are fully retracted. In this condition, the level of fluid in the sight tube should be between the level marks on the decal.

**NOTE:** *If the fluid level is below the bottom level mark, add fluid BEFORE attempting to operate the baler. Refer to the following "Adding Fluid to Reservoir" topic for proper refilling procedures.*

## WARNING

**DO NOT** remove any hydraulic lines or fittings until the system is depressurized and there is no load on any hydraulic components. Failure to heed may result in personal injury.

## WARNING

**NEVER** contaminate the reservoir fluid with any flammable liquid. **ONLY** use non-flammable cleaning solvents for cleaning components or containers used for storing, transporting or transferring the fluid. If the fluid should become contaminated with a flammable liquid, the resulting mixture, when combined with compressed air, can explode and cause death or serious injury.

1. Make sure TDC cylinders are fully retracted (baler empty and tailgate closed and latched).
2. Clean the top of the reservoir to prevent any contamination during draining or refilling.
3. Fully depressurize the system by loosening or removing (and retaining) the valve from inside the stem on the inlet at the top of the reservoir.
4. Remove and retain the relief valve adapter from the top of the reservoir.
5. The TDC system comes filled from the factory with a special grade of hydraulic oil capable of operating at lower ambient temperatures than normal hydraulic oils. If low temperatures and slow shuttle returns are not a problem, ATF (Dexron II) is an acceptable oil to use in the TDC system. Add the necessary amount of fluid through the relief valve adapter opening to bring the level in the sight tube in line with the lower level mark on the TDC reservoir (both density cylinders **MUST** be fully retracted when using the lower level mark).

## Chapter 6 - Care & Maintenance (Service)

6. After the proper amount of fluid has been added, reinstall and secure relief valve adapter (and valve stem, if removed) at top of the reservoir.
7. Using air pressure ONLY, repressurize the system to 170 PSI (1172 kPa).

If the system has air in it (or gets air into it from opening a hydraulic line), it MUST be reprimed. Or, if the system requires complete draining (for example, to change to a lighter or heavier fluid), refer to the “System Draining and Repriming Procedure” topic for details.

### D: System Draining and Repriming Procedure (Fig. 108)

1. Make sure TDC cylinders are fully retracted (baler empty and tailgate closed and latched).
2. Clean the top of the reservoir to prevent any contamination during draining and refilling.
3. Fully depressurize the system by loosening or removing (and retaining) the valve stem from the inlet at the top of the reservoir.
4. Remove and retain the hardware securing the trip spacer to the trip arm for the right side density cylinder and remove the trip spacer. This MUST be done to prevent accidental activation of the valve trip mechanism.
5. Fully extend both density cylinders by pulling on the belts at the back of the baler (this will pull the shuttle back and extend the cylinders), and then block them in the extended position so they will NOT retract.
6. Check the fluid level in the reservoir. With both density cylinders fully extended, the fluid level should be 13-16" (330-400 mm) above the bottom of the reservoir.

If fluid must be added, go to Step 9. If fluid is to be drained and replaced, continue to Step 7. If repriming is all that is required, go to Step 9.

7. Place a 2 gallon (8 liter) or larger container near the right side density cylinder to catch the fluid during draining. Disconnect the TDC reservoir hydraulic hose at the manifold disconnect and allow the fluid to drain into the container.

**IMPORTANT:** *Whenever service is performed on hydraulic components (valves, cylinders, hoses, etc.), care must be taken to prevent discharging fluid onto the ground. Catch and dispose of fluid per local waste disposal regulations.*

8. After draining is completed, reconnect the hydraulic hose at the manifold disconnect.
9. Remove and retain the relief valve adapter from the top of the reservoir.
10. The TDC system comes filled from the factory with a special grade of hydraulic oil capable of operating at lower ambient temperatures than normal hydraulic oils. If low temperatures and slow shuttle returns are not a problem, ATF (Dexron II) is an acceptable oil to use in the TDC system. Add the necessary amount of fluid through the relief valve adapter opening to bring the level in the sight tube to 13-16" (330-400 mm) above the bottom of the TDC reservoir.
11. After the proper amount of fluid has been added, reinstall and secure the relief valve adapter (and valve stem, if removed) at top of the reservoir.
12. Check the belts to MAKE SURE that they are not twisted and remove any blocking used to hold the density cylinders in the extended position.
13. Using air or compressed nitrogen, repressurize the system to 170 PSI (1172 kPa). Repressurizing the reservoir forces oil through the hydraulic lines and retracts the density cylinders.



## WARNING

**DO NOT exceed 300 psi (2068 kPa) regulator setting when using nitrogen to pressurize the TDC system. Special care must be taken with tanks, regulators, hoses and fittings to avoid damaging them in handling.**

---

14. Bleed any air that may have entered the density cylinders by carefully opening the bleed valve at the top of each density cylinder. Also bleed any air out of the hydraulic cap.

With the density cylinders retracted, the oil level in the sight tube MUST be between the two oil level marks. Overfilling can result in TDC pressure loss.

**NOTE:** *It may be necessary to repeat steps 3 and 9 through 13 several times in order to completely bleed the air from the density cylinders and obtain the correct oil level.*

15. Reinstall the trip spacer and secure it to the trip arm. MAKE SURE that the trip spacer properly contacts the valve trip mechanism before resuming baling.

## E: Pressure Relief Valve (Figs. 108 & 109)

### 1: Faulty Valve Operation

Malfunction of the adjustable pressure relief valve is suspected if one or more of the following conditions arise while baling:

1. On 2480 and 2780 balers, if desired density bale can not be produced, contamination may be keeping the relief valve poppet from seating properly. A leaky trip lever valve or check valve could also cause low bale density or low pressure readings. To test this: first, fully depressurize the system by loosening or removing (and retaining) the valve stem from the inlet at the top of the reservoir. Then, remove the pipe plug from the top of the adjustable relief valve manifold and in its place, install a 1000 PSI (6895 kPa) MINIMUM pressure gauge. Next, loosen the locking ring on the adjustable relief valve (turn it counterclockwise) and then, gently turn the end disc clockwise until it bottoms. Now, remove the trip spacer and rotate the valve trip mechanism clockwise to its upper stop position. Make sure that there is sufficient fluid in the reservoir and then open the gate to extend the density cylinders. The indicated pressure on the pressure gauge (installed above) MUST be at least 500 PSI (3447 kPa), otherwise the relief valve poppet is NOT seating properly.

On 2580, 2680 and 2880 balers, the gauge on the front of the baler will indicate if the system is operating correctly. When the density cylinders are retracted, the reservoir pressure should be 170 PSI (1172 kPa). When building a bale and after the trip lever has been activated, the needle in the front gauge should be in the middle 1/3 of the green range on the gauge. The amount of hay being fed into the baler will affect the pressure reading. The heavier the hay, the higher the pressure reading, and with lighter hay, the pressure will read lower. If there isn't any hay being fed into the baler, the pressure may drop, causing the needle in the gauge to read in the lower 1/3-1/8 of the green range.

2. If the density control cylinders will not retract quickly, contamination may be blocking the check valve and preventing the hydraulic oil from flowing freely through the valve. To check this, turn the valve trip mechanism to its counterclockwise stop position when the density cylinders are extended. If the cylinders quickly retract, the check valve is malfunctioning.
3. On 2480 and 2780 balers, if excess power is required for baling, or if frequent belt failure is experienced, contamination may be blocking the relief valve poppet, thereby preventing free flow of fluid through the valve. To test this, use the same test procedures as for Step 1 above, and if the gauge reading rises above 700 PSI (4826 kPa), the relief valve may be blocked.

On 2580, 2680 and 2880 balers, if the gauge on the front of the baler reads in the upper 1/4 of the green range or into the red range, the relief valve may be sticking, or there is an obstruction in the line.

If any or all of the above situations occur, the pressure relief valve can be partially disassembled following details in the next topic.

### 2: Relief Valve Removal & Replacement

If the adjustable pressure relief valve is suspected of leaking or blockage, it can be partially disassembled in the following manner:



## WARNING

**DO NOT remove any hydraulic lines, fittings or components until you are sure that the system is depressurized and that there is no load on any hydraulic components. Failure to heed may result in personal injury. To fully depressurize the system, loosen (or remove and retain) the valve stem from the inlet at the top of the reservoir (see Ref. 2, Fig. 110).**

---

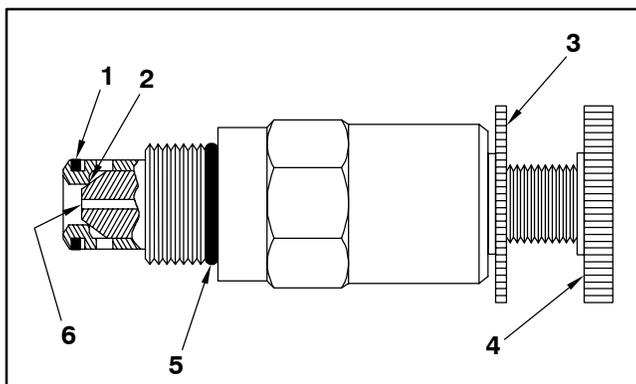

- 1 - Ring & backup washer
- 2 - Area of possible contamination
- 3 - Locking ring
- 4 - End disc
- 5 - O-ring
- 6 - Poppet

**Fig. 109: Adjustable Relief Valve Cartridge**

1. MAKE SURE the system is depressurized. Also, MAKE SURE the density cylinders are fully retracted and there is no bale in the machine.
2. Carefully disconnect the reservoir-to-manifold hose at the manifold disconnect coupler.

**IMPORTANT:** Whenever service is performed on hydraulic components (valves, cylinders, hoses, etc.), **care must be taken to prevent discharging fluid onto the ground.** Catch and dispose of fluid per local waste disposal regulations.



## WARNING

**BE SURE** to wear a face and eye protection shield or goggles and position yourself so that your face is away from the valve to prevent contact with the escaping fluid.

3. Carefully loosen the adjustable relief valve and bleed off pressure from the system.
4. After pressure has been removed, the valve can be removed from the manifold and the opening should be plugged to prevent contamination.
5. Inspect the cartridge for a leaky or blocked poppet. Force the poppet on the front end of the cartridge backward and, using a clean punch, rotate the poppet to dislodge any contamination.
6. After step 5 has been performed, check the two outside O-rings for damage and then replace the cartridge into the manifold.
7. Carefully and properly reconnect quick coupler.
8. Check the reservoir fluid level and pressurize to 170 PSI (1172 kPa) before attempting to resume operation. Add fluid if required.

**NOTE:** If the baler fails to operate properly after the above procedures have been carried out, contact your dealer for further directives. To order replacement valve cartridge, specify Gehl part number 141471 (2480) or 141472 (2580, 2680, 2780 & 2880).

To repair cartridge, specify Gehl part number 094193 for seal kit. Replace check valve with Gehl part number 119302.

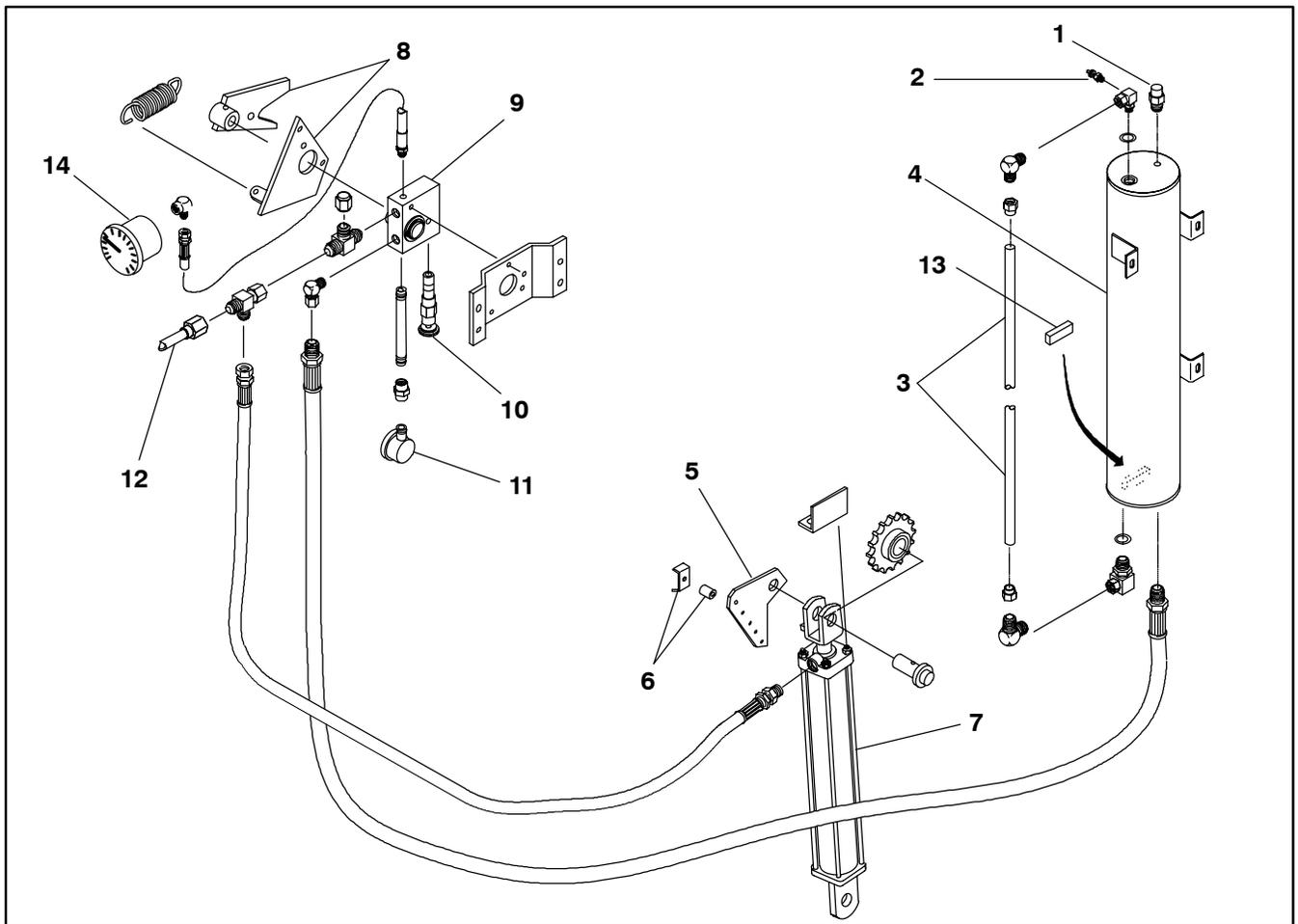

- 1 - Relief valve & adapter
- 2 - Valve stem
- 3 - Sight tube
- 4 - Reservoir
- 5 - Trip arm
- 6 - Trip spacer assembly
- 7 - Right density cylinder

- 8 - Valve trip mechanism
- 9 - Manifold
- 10 - Relief valve cartridge (070633)
- 11 - Pressure gauge
- 12 - To left density cylinder
- 13 - Magnet (inside reservoir)
- 14 - Tractor viewable pressure gauge (2580, 2680 & 2880)

Fig. 110: Total Density Control (TDC) System

## Transmission

**IMPORTANT:** *Internal transmission component repairs and replacements should only be attempted by (or under the direction of) an authorized Gehl equipment dealer.*

To remove transmission for service, proceed as follows:

1. Drain oil as directed in "Lubrication" section of this chapter.
2. Remove windguard assembly.
3. Remove twine tie system (five bolts, one electrical connection on manual tie, two electrical connections on auto-electric models).

4. Release drive chain tension, break the drive chain, remove sprocket on cross shaft and loosen the bearing attaching hardware.
5. Loosen four flangette mounting bolts on cross shaft.
6. Slide cross shaft off of transmission output shaft.
7. Remove the (four) fasteners securing the transmission housing to the crosstube.
8. Carefully remove the transmission from the unit.

After service is performed, replace the transmission in reverse order of removal. Then, replace the oil until it reaches the full mark on the dipstick. The transmission requires 1 U.S. quart (0.95 L) of SAE 80W90 EP gear lube. Replace and readjust the drive chain.

## Twine Knife

When sharpening the twine knife, only sharpen the beveled edge. Remove the (two) bolts to take the knife off the cut-off arm.

## Belts



## WARNING

**BEFORE servicing this unit, exercise the MANDATORY SAFETY SHUTDOWN PROCEDURE (page 8).**

## Activating Shuttle Lock (Fig. 111)



## WARNING

**BEFORE servicing the belts, BE SURE to release the tension on the belts with the shuttle lock. NEVER have the PTO engaged while the shuttle lock is engaged.**

To use the shuttle lock on the left side of the baler, first unlatch the lock and then open the gate. The spring-loaded lock will deploy as the shuttle retreats. Then slowly close the gate. To deactivate the lock, open the gate, retract and latch the lock and then close the gate. Earlier model balers were equipped with shuttle locks on both sides of the baler.

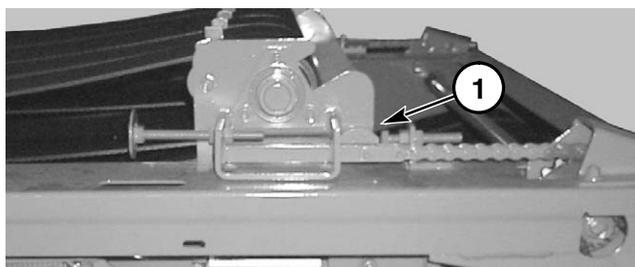

1 - Shuttle lock "engaged"

Fig. 111: Early Model Baler

### A: Belt Tension (Fig. 110)

If the belts do not return or otherwise are not returning fast enough after ejecting a bale, check out the following items in the order listed to troubleshoot and correct the problem.

1. Check the gauge pressure for the reservoir while the baler is empty. If the pressure reads less than 170 PSI (1172 kPa), add air to bring the pressure up to 170 PSI (1172 kPa). If the pressure drops again after a short time, there is most likely a leak at one of the fitting connections. To find the leak, apply a soapy water solution to the fittings and watch for air bubbles to form. As necessary, tighten the fitting connection or replace the fitting. Be careful not to overtighten the fittings and damage the threads.
2. Check the reservoir hydraulic fluid level. With the cylinders fully retracted, the fluid should be between the two oil level marks on the reservoir. Refer to TDC System topic in this chapter under Reservoir subtopic for additional information.
3. Check the plumbing arrangement and compare your machine to the routing shown in the TDC hydraulic circuit diagram provided.
4. Check the operation of the pressure relief valve following details under the Pressure Relief Valve subtopic contained within the TDC System information in this chapter.
5. Check for sticking density cylinders. Release the reservoir air pressure. Remove the trip spacer from the trip arm and then fully extend both density cylinders by pulling the belts at the back of the baler. Slowly pressurize the reservoir to 25 PSI (172 kPa). Cylinders should retract completely and smoothly. Check TDC cylinder vents and be sure the cylinder is not leaking.

### B: Cause of Belt Failure

When a belt fails, it will usually occur in the area of lacing hooks and will be caused by one or more of the following:

1. Bale improperly formed.
2. Lacing wire worn or broken. Replace lacing wire on 2480 and 2780 balers every 500 bales.
3. Belt not properly laced.
4. Belts not tracking properly.
5. Build-up on roller(s) or scraper.
6. Baling when conditions are too wet.

### C: Splicing and Re-lacing (Fig. 112) (2480 and 2780, Belts Laced with Hook Style Lacing)

When replacing a belt or section of a belt, it is important that the same type of belting is used as a replacement.

Failure to do so can result in premature failure to other belts or to the belt that has just been repaired.

**NOTE:** When the baler is empty and the shuttle is pulling the belts tight, the overall length of the belts should be within 2-1/2" (64 mm) of each other. If not, it may be necessary to add a Dutchman section to a shorter belt or to shorten a longer belt to even out the belt lengths.

Belts are laced with #4-1/2HT clipper lacing hooks and 3/32" (2.4 mm) diameter nylon-coated cable. These materials and a 6" (152 mm) belt vice lacer can be obtained as service accessories; see the Optional Features & Accessories chapter of this manual.

To re-lace a belt, the following additional items will be needed: small square, ball-point pen, sharp knife, long-nose pliers, slip-joint pliers and a vice.

To re-lace a belt, follow the procedure below:

1. Open the rear gate, engage the shuttle locks and completely close gate to remove belt tension. Then remove the belt to be re-laced.
2. Mark the belt with the small square and ball-point pen just behind the old hooks or 5/8" (15.9 mm) from the end of the belt. Carefully cut the belt with a sharp knife. Check the squareness from both sides after cutting. Clip the corners as shown.

**NOTE:** Re-lace both ends of a pulled lacing joint. By limiting the amount of belt cut to 5/8" (15.9 mm) on each end, a belt can be re-laced twice before alternative action is required; see "Maintaining Belt Length" section for details.

3. Install #4-1/2HT hooks with the vice lacer. Make sure the ends of the hooks protrude through the belt and are clinched over.
4. Make sure outside hooks are on the leading belt end. Install re-laced belt in the baler.
5. Cut an 8" (203 mm) long piece of nylon-coated cable. Bend a 3/4" (19 mm) loop in one end of the cable. Install cable in splice positioning loop as shown.
6. Restore belt tension by opening the rear gate and returning the shuttle locks to storage.
7. Using the long-nose pliers, trim and bend the remaining end of the Cable into a loop with a minimum of 3/4" (19 mm) engagement into the lacing.

**NOTE:** To keep the belt splice in good operating condition, it is recommended that the lacing cables be replaced every 500 bales.

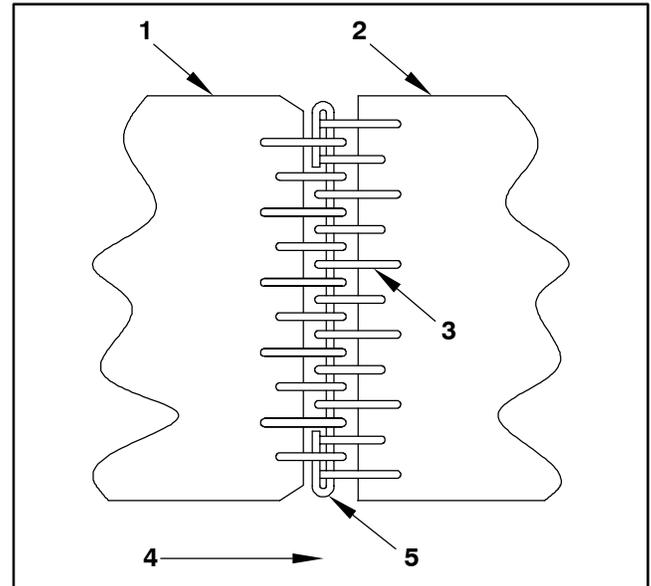

- 1 - Trailing end
- 2 - Leading end
- 3 - Outside lacing hook
- 4 - Direction of belt travel
- 5 - Lacing pin (cable)

Fig. 112: Hook Style Lacing

#### D: Splicing and Re-lacing (Fig. 113) (2580, 2680 and 2880, Belts Laced with Alligator® Style Lacing)

These instructions detail the procedure for repairing a belt that is laced with the Alligator® hinge style lacing. Depending on the situation, re-lacing a belt may involve a new belt installation or some other form of belt repair or partial replacement.

As appropriate, a lacing tool, 16 oz. hammer, small square, ball-point pen, small hand grinder and sharp knife may be required to install new lacing hinge, when necessary. A pliers will also be required to bend the hinge pin after the pin has been used to join the two hinges fastened to either end of the belt.

When replacing a belt or section of a belt, it is important that the same type of belting is used as a replacement. Failure to do so can result in premature failure to other belts or to the belt that has just been repaired.

**NOTE:** When the baler is empty and the shuttle is pulling the belts tight, the overall length of the belts should be within 2-1/2" (64 mm) of each other. If not, it may be necessary to add a Dutchman

## Chapter 6 - Care & Maintenance (Service)

section to a shorter belt or to shorten a longer belt to even out the belt lengths.

To re-lace a belt, use the following procedure:

1. When necessary and using a small square and ball-point pen, mark the belt just behind the old hooks or 5/8" (15.9 mm) from the belt end. Using a sharp knife, carefully cut the belt while making sure the cut is square with both edges of the belt. Then, trim the "trailing belt" edge corners, as shown in Fig 1. As applicable and using a small hand grinder, remove 3/4" (19 mm) of the chevron pattern from each belt end. The thickness of the belt under the lacing should be 3/16 to 13/64" (4.8 to 5.2 mm) thick.
2. Place one half of complete 6" (152 mm) (13 plates and 26 loops) belt hinge into lacing tool using pins in tool to hold hinge in place. Slide belt under tool clamps and up to stop pins in tool. At this point, the belt should be inside open hinge. Be sure belt is squarely placed in tool and the lacing is located properly. Tighten clamps securing belt in lacing tool.

**NOTE:** *BE SURE hinge is offset slightly to one side of the belt so that the edges of the mated belt joint are in line as shown in Figure 113.*

3. Tap down all fasteners with a hammer.
4. Starting at one end of the hinge, place point of a rivet into hole of lacing hinge and drive point of rivet through belt and out bottom hole of lacing hinge. **DO NOT** distort lacing hinge. Repeat until all 13 rivets have been driven into lacing hinge.
5. Drive rivets down evenly, a little at a time starting at one end of hinge and working back and forth. Continue until hinge plates are slightly pushed into rubber belting and rivet pins have released. **DO NOT** collapse loops of lacing hinge.
6. Remove belt from lacing tool and place newly laced end up to adjoining hinge so that loops from each end intermesh with each other. Insert hardened hinge pin through the loops fastening the two belt ends together. Secure pin in place by bending straight end of pin in same direction as already formed end

**NOTE:** *BE SURE belt is routed correctly in baler before joining both ends of belt.*

7. Disengage shuttle locks to restore belt tension as described in unit's Operator's Manual.

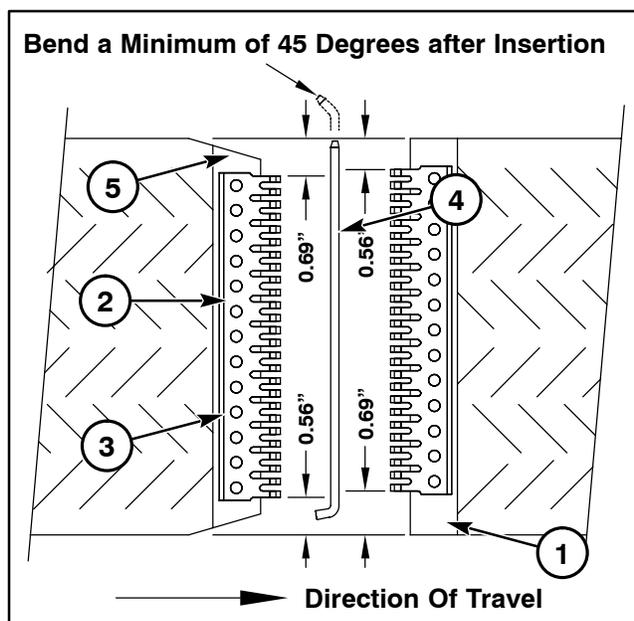

Fig. 113

### D: Maintaining Belt Length

The length of the belts should be maintained within 2-1/2" (64 mm). This 2-1/2" (64 mm) difference between belt lengths can be achieved in either of two ways:

- a. by switching belts around to different positions, or
- b. by using Dutchman splices.

#### 1: Switching Belts

The lacing on the outside belts is more likely to fail before the inside belt lacing. Outside belts that have already been re-laced can be switched towards the center of the baler where less stress will be placed on the lacing.

**NOTE:** *This practice of switching is the recommended procedure for purposes of expense and repair time reduction.*

#### 2: Dutchman Splice

The original or matching belt length can be restored by using a Dutchman splice on a belt which has been shortened excessively by repeated re-lacings, a diagonal cut or a tear.

**NOTE:** *It is important to keep an accurate record of re-lacing for each belt so that a belt can be*

re-laced twice before the belt is switched or a Dutchman is necessary.

### E: Dutchman Splice Installation

**NOTE:** The Dutchman splice **MUST** be at least 12" (305 mm) in belt length for ample lacing separation. If lacings are staged too close together, the belt lacings will fail quicker. **BE SURE** to use the longest Dutchman available as the piece that will be cut off. The long belt will (hopefully) be good enough for more than 1 foot (305 mm) and then itself be usable as a Dutchman. Refer to the *Optional Features & Accessories* chapter for available Dutchman.

#### 1: 2480 and 2780 Belts (Fig. 114)

Perform the following steps to restore a short or torn 2480 or 2780 belt:

1. Cut one end off the long belt as close to the damaged area as possible and without including the damaged area. Re-lace this end.
2. Determine what overall length of belt has to be developed (belt length only, NOT including lacing). To determine the overall length, consider the following:
  - a. A new belt is 469" (11.9 mm) long.
  - b. Belts should be maintained within 2-1/2" (64 mm) of each other.
  - c. Check your records as the belt may already have been reduced in length due to previous lacing failures.
3. After the overall length required has been determined, subtract the following:
  - a. Dutchman belt length
  - b. Extra gap necessary of 1/2" (12.7 mm)
4. After the above measurements and calculations are made, cut the long belt to the appropriate length determined and re-lace it.
5. Install the cable lacing pin in one joint, reassemble the belt into the baler and install the other cable lacing pin.

#### Example

Given a 36" (914 mm) Dutchman and a full length belt that is badly torn and now needs to be re-laced. To what length should the damaged belt be cut? Refer to Fig. 114 and follow the calculation below.

#### Solution

Belt Length Desired? (This may be less than 469" if all other belts have already been cut off)	469"
Minus Dutchman Belt Length	-36"
Minus Additional Belt Gap (Due to Additional Lacing)	-1/2"
	432-1/2"

Therefore, belt **MUST** be cut to a length of 432-1/2"

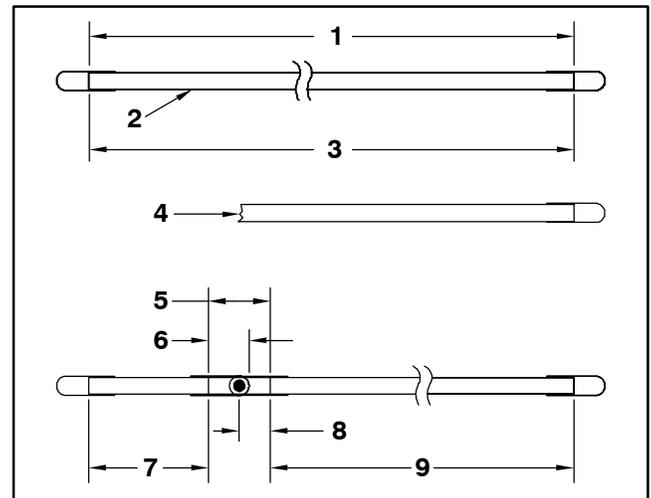

**A + B + 1/2" (12.7 mm) = Belt Length Desired**

- 1 - 469" (11 913 mm)
- 2 - New belt
- 3 - Belt length desired
- 4 - Tear
- 5 - 1/2" (12.7 mm)
- 6 - 3/8" (9.5 mm)
- 7 - 35-1/4" (895 mm)
- 8 - 1/4" (6.4 mm)
- 9 - 432-1/2" (10 986 mm)

**Fig. 114: 2480 & 2780 Belt Repair Detail**

#### 2: 2580, 2680 & 2880 Belts (Fig. 115)

There are four different length belts used on 2580, 2680 and 2880 balers. These finished lengths (measured end to end including lacing) are 475" (12 065 mm), 502.5" (12 764 mm), 556" (14 122 mm) and 578.5" (14 694 mm). The 2580 Baler uses two 502.5" (12 764 mm) and four 475" (12 065 mm) belts. The 2680 baler uses two 556" (14 122 mm) and four 578.5" (14 694 mm) belts. The 2880 baler uses four 556" (14 122 mm) and four 578.5" (14 694 mm) belts.

The following example discusses the steps required to add a Dutchman to a 556" (14 122 mm) belt. Other length belts are done in a similar manner. Perform the following steps to restore a short or torn 556" (14 122 mm) belt:

**Chapter 6 - Care & Maintenance  
(Service)**

1. Cut one end off of the long belt as close to the damaged area as possible and without including the damaged area. Re-lace this end.
2. Determine what overall length of belt has to be developed (belt length only, NOT including lacing). To determine overall length, consider following:
  - a. A new belt is 556" (14 122 mm) long.
  - b. Belts should be maintained within 2-1/2" (64 mm) of each other.
  - c. Check your records as the belt may already have been reduced in length due to previous lacing failures.
3. After the overall length required has been determined, subtract the following:
  - a. Dutchman belt length
  - b. Extra gap necessary of 1/2" (12.7 mm)
4. After the above measurements and calculations are made, cut the long belt to the appropriate length determined and re-lace it.
5. Install the cable lacing pin in one joint, reassemble the belt into the baler and install the other cable lacing pin.

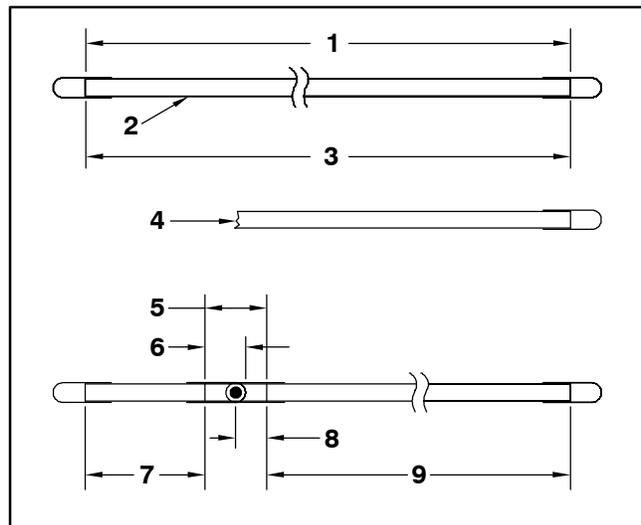

**A + B + 1/2" (12.7 mm) = Belt Length Desired**

- 1 - 556" (14 122 mm)
- 2 - New belt
- 3 - Belt length desired
- 4 - Tear
- 5 - 1/2" (12.7 mm)
- 6 - 3/8" (9.5 mm)
- 7 - 35-1/4" (895 mm)
- 8 - 1/4" (6.4 mm)
- 9 - 519.5" (13 195 mm)

**Fig. 115: 2580, 2680 & 2880,  
Typical Belt Repair Detail**

**Example**

Given a 36" (914 mm) Dutchman and a full length belt which is badly torn and now needs to be re-laced. To what length should the damaged belt be cut? Refer to Fig. 115 and follow the calculation below.

**Solution**

Belt Length Desired? (This may be less than 556" if all other belts have already been cut off)	556"
Minus Dutchman Belt Length?	-36"
Minus Additional Belt Gap? (Due to Additional Lacing)	-0.5"
	519.5"

Therefore, belt MUST be cut to a length of 519.5"

**F: Belt Routings**

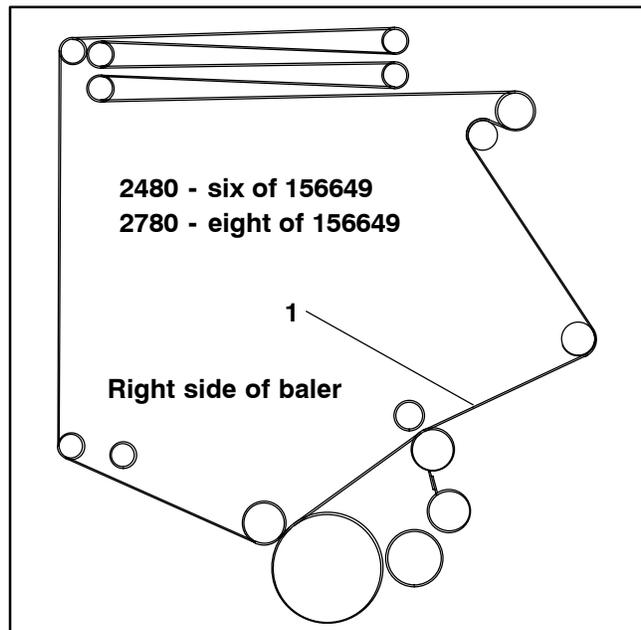

- 1 - All belts

**Fig. 116: Belt Routing for 2480 and 2780**

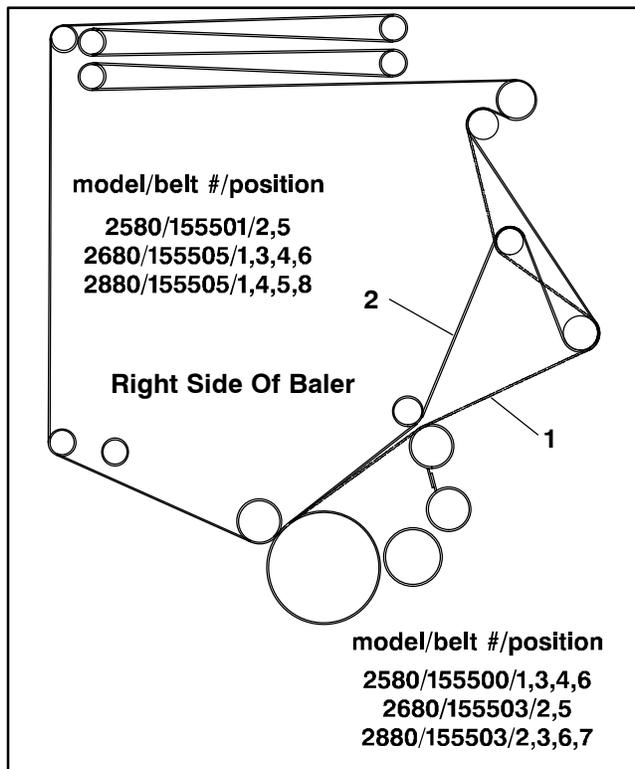

- 1 - Routing of short belt
- 2 - Routing of long belt

Fig. 117: Belt Routing for 2580, 2680 and 2880

### Driveline Slip Clutch

On balers equipped with the 1000 RPM drive, the slip clutch may have lost its torque value if the clutch has experienced a significant number of slips for extended periods of time. New friction discs may be required to rebuild the clutch. Another indication is if the tabs on the pressure plate are bottoming out in the notches located in the clutch housing.

To remove the friction discs, the driveline must be removed from the implement. Remove the two 1/2 x 2-3/4" retaining bolts and slide the driveline off the baler PTO shaft. Remove the six 5/16 x 2-1/2" bolts that hold the compression plate to the housing. Retain this hardware. Remove the compression plate and note the position of the spring disc. The inside diameter should

be contacting the pressure plate and the outside diameter of the spring disc should first contact the compression plate. Next remove the pressure plate, friction disc, separator plate, and second friction disc from inside the housing. The friction discs may stick to the knurled separator plate, and should be pulled off.

**NOTE:** It is normal for the friction disc to have a dark black glazed appearance with hairline cracks on the surface.

Clean any remaining friction material from the knurled faces with a wire brush. Clean the housing and smooth surfaces of the pressure plate with a wire brush. Install the new friction disc into the housing followed by the separator plate, the second new friction disc and the pressure plate. Install the spring disc and compression plate as described above. Re-install the retained hardware and tighten until the compression plate is drawn up against the clutch housing. Install the driveline back onto the baler.

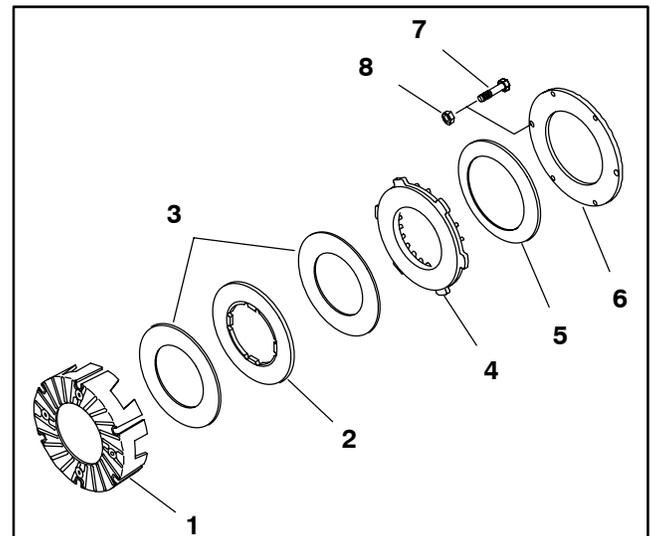

- 1 - Clutch housing
- 2 - Separator plate
- 3 - Friction discs (two)
- 4 - Pressure plate
- 5 - Spring disc
- 6 - Compression plate
- 7 - 5/16 x 2-1/2" cap screws (six)
- 8 - 5/16" nuts (six)

Fig. 118

## Wheels & Tires

**NOTE:** Gehl Company does not sell replacement tires. In addition, tire mounting, repair and replacements should *ONLY* be attempted by a qualified tire manufacturer's representative or by properly trained personnel following the tire manufacturer's instructions. If you do not have such instructions, contact your tire dealer or Gehl Company.

Check the baler tire pressure after every 50 hours of operation. Tires should be inflated to the 40 PSI (276 kPa). Wheel lug nut torque should be checked after every 50 hours of operation and tightened to 90 lb.-ft. (122 Nm) torque.



## WARNING

Inflating or servicing tires can be hazardous. Whenever possible, trained personnel should be called to service and mount tires. To avoid possible death or serious injury, follow the safety precautions below:

- **BE SURE** the rim is clean and free of rust.
  - **Lubricate both the tire beads and rim flanges with a soap solution. DO NOT use oil or grease.**
  - **Use a clip-on tire chuck with a remote hose and gauge, which allows you to stand clear of the tire while inflating it.**
  - **DO NOT** place your fingers on the tire bead or rim during inflation.
  - **NEVER** inflate beyond 35 PSI (241 kPa) to seat the beads. If the beads have not seated by the time the pressure reaches 35 PSI, deflate the assembly, reposition the tire on the rim, relubricate both parts and re-inflate it. Inflation pressures beyond 35 PSI with unseated beads may break the bead or rim with explosive force sufficient to cause death or serious injury.
  - **After seating the beads, adjust the inflation pressure to the recommended operating pressure listed.**
  - **DO NOT** weld, braze, or otherwise attempt to repair or use a damaged rim.
-

# CHAPTER 7

## STORAGE

The following items are recommended for off-season storage of the baler:

1. Remove all crop material and debris from behind the sprockets, sheaves, ends of the rollers, pickup, etc.
2. Grease all fittings and make sure the telescoping PTO drive is completely greased. Repack the wheel bearings. Also, apply a light coat of grease to the twine knife.
3. On the 2480 and 2780 balers, release tension from the V-belt which drives the pickup.
4. Where possible, hydraulic cylinders should be fully retracted and any exposed cylinder rods should be coated with grease.
5. Apply clean motor oil to all roller chains, telescoping drive shields and guard door hinges.
6. Store the unit inside a shed, if possible, or cover the top half of the unit to protect the belts, if stored outside.
7. Reorder and replace any required parts so that the baler will be ready to operate at the start of the next baling season.
8. Cover and protect all exposed electrical connectors from dirt and corrosion.
9. Store control boxes in a protected dry area out of the weather.

**NOTE:** Before starting up each season, go over the Checklists chapter of this manual.

### PROTECTION OF UNPAINTED SURFACES

Apply a rust preventative oil or grease to the following unpainted surfaces:

1. All roller chains and sprockets.
2. The front PTO drive yoke and PTO shaft.
3. Inside side sheets where paint is worn off.

The following item is recommended for pre-season startup of the baler (1000 RPM only). Perform the clutch run-in procedure as outlined in the steps below.

1. Open the drive line shield.
2. Loosen (but do NOT remove) the six clutch bolts (see Fig. 119).
3. Rotate the drive line by hand until the clutch slips.
4. Tighten the six clutch bolts.
5. Close the drive line shield.

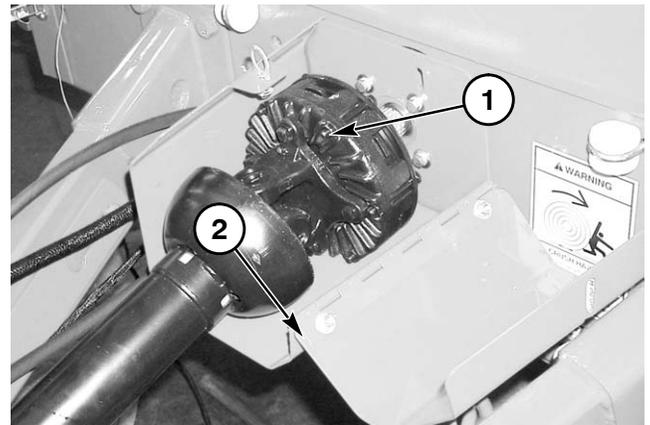

1 - Clutch bolt (1 of 6)  
2 - Drive line shield

Fig. 119

# CHAPTER 8

## TROUBLESHOOTING

**NOTES** This Troubleshooting guide presents problems, causes and suggested remedies beyond the extent of loose, worn or missing parts and it was developed with the understanding that the machine is in otherwise good operating condition. Refer to the index at the back of this manual for Chapter and Topic page references. **BE SURE** to exercise the **MANDATORY SAFETY SHUTDOWN PROCEDURE** (page 8), **BEFORE** making any adjustments or repairs.

### BALE APPEARANCE

PROBLEM	CAUSE	REMEDY
Bale density is greater in the center than on the ends (bale is barrel-shaped).	Improper placement of material along edge of bale.	Re-rake material into a proper width windrow or drive baler in a weaving fashion.
	Adjustable relief valve pressure is set too low.	Increase relief valve pressure.

### BALE DENSITY

PROBLEM	CAUSE	REMEDY
Low bale density.	Adjustable relief valve pressure is set too low.	Increase relief valve pressure.
	Low reservoir pressure.	Increase air pressure to 170 PSI (1172 kPa).
	Trip spacer on trip arm is not engaging the valve trip mechanism.	Adjust so that they are in line.
	Poppet in adjustable relief valve not seating properly or 3/8" (9.5 mm) diameter poppet is grooved.	Remove, inspect and clean relief valve cartridge per instructions in "Service" section of Care & Maintenance chapter. Repair with Gehl part number 094193 seal kit.
	Air in the hydraulic lines or fluid level too low in reservoir.	Re-prime system. Refill with correct oil.

### BALE FILLING & BELTS

PROBLEM	CAUSE	REMEDY
Bale fails to rotate or rotates sporadically.	Belt pinched.	Look for areas that might have pinched or trapped the belt.
	Material has too high of a moisture content.	Use Silage Special baler.
	Pressure relief setting too low.	Increase relief pressure setting.
	Low pressure in reservoir.	Increase air pressure to 170 PSI (1172 kPa).
	Driveline disconnect clutch not engaged.	Stop and re-start tractor PTO.

**BALE FILLING & BELTS (cont.)**

<b>PROBLEM</b>	<b>CAUSE</b>	<b>REMEDY</b>
Belts getting under bale starter fingers when closing gate.	<p>Bale starter sticking in up position.</p> <p>Low reservoir pressure.</p> <p>Extremely cold conditions.</p> <p>TDC oil too thick for cold conditions.</p>	<p>Lubricate all of the pivots on the bale starter assembly. Leave PTO running while closing gate.</p> <p>Increase pressure to between 170 PSI (1172 kPa).</p> <p>When ejecting bale, open gate with PTO off, wait until shuttle stops, engage PTO, close and latch gate.</p> <p>Use recommended oil for TDC system; see "Lubrication" section of Care &amp; Maintenance chapter.</p>
Belt lacing hooks tearing out frequently.	<p>Bale improperly formed.</p> <p>Lacing pin worn.</p> <p>Belt improperly laced.</p> <p>Belt NOT tracking properly.</p> <p>Build-up on scraper or rollers.</p> <p>Conditions too wet.</p> <p>Hooks or rivets improperly installed.</p> <p>Adjustable relief valve pressure too high for crop conditions.</p>	<p>Correctly form next bale; see "Baling" topic in Operation chapter.</p> <p>Replace the lacing pin.</p> <p>Correctly lace belt.</p> <p>Correct belt tracking; see "Service" section of Care &amp; Maintenance chapter.</p> <p>Remove build-up.</p> <p>Stop baling and wait for material to dry.</p> <p>Correctly install hooks and rivets.</p> <p>Reduce relief valve pressure.</p>
Belts are making squealing noise.	<p>Baler is being run empty for too long a period of time.</p> <p>Gate end roller improperly adjusted.</p> <p>Crop has too high a moisture content. Belt getting wet.</p> <p>Shuttle returning too slow.</p> <p>Belts rubbing together in rear.</p>	<p>Run baler empty for a shorter time.</p> <p>Readjust end roller; see "Adjustment" section of Care &amp; Maintenance chapter.</p> <p>Use Silage Special baler.</p> <p>Increase reservoir pressure to 170 PSI (1172 kPa).</p> <p>Reduce bale diameter.</p>

**BALE FILLING & BELTS (cont.)**

<b>PROBLEM</b>	<b>CAUSE</b>	<b>REMEDY</b>
Belts traveling to the side (excessively).	<p>Lacing is NOT square to belt edge.</p> <p>Belt shuttle NOT square.</p> <p>Belt length variation greater than 2-1/2" (64 mm).</p> <p>Belt tracking roller improperly adjusted.</p> <p>Tailgate roller improperly adjusted.</p>	<p>Properly square edge and re-lace belt.</p> <p>Readjust belt shuttle; see "Adjustment" section of Care &amp; Maintenance chapter.</p> <p>Re-lace or replace belts that are too short.</p> <p>Readjust belt tracking roller; see "Adjustment" section of Care &amp; Maintenance chapter.</p> <p>Readjust belt tracking roller; see "Adjustment" section of Care &amp; Maintenance chapter.</p>
Gate opens prematurely while bale is still being formed.	<p>Gate cylinders are NOT fully retracted to activate latch.</p> <p>Gate latch improperly adjusted.</p> <p>Improper use of tractor hydraulics or closing the gate with the hydraulics in the float position.</p> <p>Tractor has faulty hydraulics.</p> <p>Tractor has low GPM output.</p>	<p>Fully retract cylinders. If NOT possible, check tractor and baler circuits.</p> <p>Readjust latch; see "Adjustment" section of Care &amp; Maintenance chapter.</p> <p>When closing the gate, tractor hydraulics should go to the relief pressure to insure that gate is latched.</p> <p>Refer to tractor manual for repair.</p> <p>Close gate as quickly as possible to force hooks to engage pins.</p>
Excessive amount of material peeling off the bale resulting in large trash build-up.	<p>Improper baling speed.</p> <p>Adjustable relief valve pressure is too high.</p>	<p>Reduce the PTO speed and increase the ground travel speed.</p> <p>Reduce relief valve pressure.</p>
Material wrapping around rollers.	<p>Moisture content too high.</p> <p>Adjustable relief valve pressure is high.</p> <p>Scraper improperly adjusted.</p> <p>Excessive PTO speed causing material to peel off the bale.</p>	<p>Stop baling and wait for material to dry.</p> <p>Reduce relief valve pressure.</p> <p>Readjust scraper; see "Adjustment" section of Care &amp; Maintenance chapter.</p> <p>Reduce the PTO speed.</p>

## CROP RELATED PROBLEMS

PROBLEM	CAUSE	REMEDY
Difficulty encountered in baling corn stalks, cane, etc.	<p>Improper baling speed.</p> <p>Improper material preparation.</p> <p>Improper clearance between pivoting power feed roller and lower feed roller.</p> <p>Material will NOT feed under pivoting power feed roller.</p>	<p>Reduce the PTO speed and increase the ground travel speed.</p> <p>Rake windrow into a full 45" (1145 mm) wide row for 4 ft. balers and a full 61" (1549 mm) wide row for 5 ft. balers.</p> <p>Readjust clearance; see "Adjustment" section of Care &amp; Maintenance chapter.</p> <p>Adjust pickup so that pickup can be carried lower. Lower windguard upper limit stop pin.</p>
Difficulty getting bale to grow in light windrow.	<p>Material is deteriorating on bale ends. Too much time spent forming bale.</p> <p>Gate end roller to 16" (406 mm) lower roller clearance too great.</p>	<p>Rake light windrows together.</p> <p>Reduce clearance; see "Adjustment" section of Care &amp; Maintenance chapter.</p>
Material kicking ahead of pickup.	<p>Improper baling speed.</p> <p>Improper material preparation.</p> <p>Improper windguard adjustment.</p>	<p>Reduce the PTO speed and increase ground travel speed.</p> <p>Increase or decrease the windrow size, as necessary.</p> <p>Lower windguard.</p>
Material wraps on pivoting power feed roller.	<p>Improper scraper adjustment.</p>	<p>Adjust scraper, see "Adjustment" section of Care &amp; Maintenance chapter.</p>

**FEEDING INTO BALER**

<b>PROBLEM</b>	<b>CAUSE</b>	<b>REMEDY</b>
Pickup can NOT be adjusted high enough or low enough.	Tractor drawbar height does NOT meet specifications.	Readjust the drawbar height in accordance with specified dimensions listed in the Operation chapter of this manual.  If available, re-adjust axle, drawbar, and pickup lift. See the "Initial Field Adjustments" section of the Operation chapter.
Material NOT feeding between pivoting power feed roller and lower feed roller.	Windguard set too high.  Spring tension too high on pivoting power feed roller.  If occurring while starting a bale.  Pickup is being carried too high for heavy windrows.	Reduce windguard's upward travel.  Loosen power feed roller spring.  Feed crop evenly until bale has started to rotate. Adjust starting fingers. See the "Bale Starter Fingers" section of the Care & Maintenance chapter.  Adjust pickup to be carried lower.
Material passes through the baler.	Gate NOT closed and latched.  Gate end roller to 16" (406 mm) lower roller clearance too great.	Close and latch gate.  Readjust clearance; see "Service" section of Care & Maintenance chapter.

**MISCELLANEOUS PROBLEMS**

<b>PROBLEM</b>	<b>CAUSE</b>	<b>REMEDY</b>
Belts return too slow or fail to return.	Reservoir pressure too low.  Faulty check valve on density cylinders.  Oil level is too low in reservoir.  Defective or contaminated relief valve.  Operating in extremely cold conditions.	Increase pressure to 170 PSI (1172 kPa).  Replace or repair faulty check valve.  Re-prime system.  Remove, inspect and clean relief valve per instructions in "Service" section of Care & Maintenance chapter.  Fill reservoir with recommended hydraulic oil (see "Lubrication" section of Care & Maintenance chapter) and set reservoir pressure 170 PSI (1172 kPa).

MISCELLANEOUS PROBLEMS (cont.)

PROBLEM	CAUSE	REMEDY
Drive chain heating.	Lack of lubrication. Install accessory chain oiler. Poor chain alignment. Relief valve pressure is too high for crop conditions. Material has too high a moisture content.	Refer to Lubrication chapter. Realign sprockets. Decrease relief valve pressure. Stop baling and wait for material to dry.

PICKING UP MATERIAL

PROBLEM	CAUSE	REMEDY
Pickup kicks up corn stalks or other lightweight materials.	Improper baling speed. Improper material preparation.	Reduce the PTO speed and increase ground travel speed. Increase the windrow size by combining windrows.
Pickup is NOT completely cleaning material off the field.	Improper baling speed. Broken or missing tines. Pickup set too high off the ground. Windrow's too wide or the material (such as straw) is falling to the sides of the pickup.	Increase the PTO speed and reduce ground travel speed. Replace broken or missing tines. Readjust pickup to lower setting. Obtain and install crowder wheels.
Pickup NOT running or running at below full speed.	Pickup set too low to the ground. Improper drive belt tension. Pickup mechanism jammed. Overfill clutch mechanism activated. Overfill clutch improperly adjusted. Pickup shear bolt sheared.	Readjust pickup to raise the setting or raise the baler axle. Readjust the tension. Clean out blockage. Wrap and eject bale and make smaller bale the next time. Readjust clutch mechanism and linkage. Replace shear bolt. See the "Overload Protection" section of the Operation chapter.
Crop sits on back of pick-up without feeding into baler.	Crop too light and fine.	Rake windrows together to get heavier windrows. Adjust windguard so back of tines are pointed up towards bottom edge of power feed roller.

**STARTING THE BALE (Deluxe models only)**

<b>PROBLEM</b>	<b>CAUSE</b>	<b>REMEDY</b>
<p>Difficulty is encountered in starting the bale to rotate.</p>	<p>RPM too high or too low.</p> <p>Material is not being fed in uniformly.</p> <p>Material is hanging up on the edges of the pickup.</p> <p>Starting finger assembly not functioning properly.</p> <p>Crop feeding over top of stripping roller.</p> <p>Material is extremely dry and windrows are too small, making it impossible for a sufficient amount of material to get into the bale chamber quick enough to start the core rolling.</p> <p>Scrapers are not adjusted closely enough.</p> <p>Material is too wet and too much hay is fed in at once.</p>	<p>Vary PTO depending on crop conditions.</p> <p>Feed crop evenly until bale has started to rotate.</p> <p>Feed crop into the center of the pickup until the core has started turning.</p> <p>Adjust starting fingers. See the "Bale Starter Fingers" section of the Care &amp; Maintenance chapter.</p> <p>Adjust starting fingers. See the "Bale Starter Fingers" section of the Care &amp; Maintenance chapter.</p> <p>Increase the windrow size by combining windrows. Use shuttle stops to provide slackened belts during core formation.</p> <p>Adjust scrapers, see "Adjustment" section of Care &amp; Maintenance chapter.</p> <p>Ease into windrow slowly.</p>
<p>Material wraps on pivoting power feed roller.</p>	<p>Improperly adjusted scraper.</p>	<p>Adjust scraper, see "Adjustment" section of Care &amp; Maintenance chapter.</p>

**WRAPPING & EJECTING BALE**

<b>PROBLEM</b>	<b>CAUSE</b>	<b>REMEDY</b>
Twine falls off left edge of bale.	<p>Twine tube is being extended too far to the left.</p> <p>Twine improperly wrapped around the bale.</p> <p>Bale improperly formed.</p>	<p>Adjust twine arm stop.</p> <p>When starting to wrap the bale with twine, place two wraps of twine at the center of the bale to secure the twine on the bale.</p> <p>Feed more material on the edges of the bale on the next bale formed; see “Baling” topic in Operation chapter.</p>
Twine will NOT start into the bale.	<p>Twine not routed properly.</p> <p>Insufficient amount of material is being fed in with twine.</p> <p>Twine tails not long enough</p> <p>Twine itself is excessively kinky; poorly made or wet.</p> <p>Twine prematurely slipping out of twine jaws.</p> <p>Twine tension is too high.</p>	<p>Reroute.</p> <p>Feed in more material.</p> <p>Adjust twine jaw rod.</p> <p>Change the type of twine.</p> <p>Deburr the edges of the clamp jaws, and/or increase the spring tension on the twine jaws.</p> <p>Loosen twine tension screws.</p>
Twine will not be placed on the left side of the baler.	<p>Obstruction in path of twine arm.</p> <p>Feeding too much crop when starting twine.</p>	<p>Remove obstruction.</p> <p>Reduce amount of crop.</p>
Twine will NOT cut.	<p>Clamp jaws will NOT latch open properly.</p> <p>Clamp jaw spring tension is too tight.</p> <p>Twine arm not home w/actuator fully retracted.</p> <p>Twine knife NOT sharp.</p>	<p>Twine arm is NOT being extended far enough to the left side and/or spring slide rod adjustment is too long.</p> <p>Readjust tension; see “Adjustments” section of Care &amp; Maintenance chapter.</p> <p>Adjust timing of twine arm.</p> <p>Sharpen or replace knife.</p>
Gate will NOT open.	<p>Gate latch improperly adjusted.</p> <p>Improper hydraulics connections.</p> <p>Gate cylinder seals bad.</p> <p>Tractor has faulty hydraulics.</p> <p>Tailgate lockout valve closed.</p>	<p>Readjust gate latch; see “Adjustments” section of Care &amp; Maintenance chapter.</p> <p>Check, repair or replace connections.</p> <p>Replace seals.</p> <p>Refer to tractor manual for repair.</p> <p>Open valve.</p>

**WRAPPING & EJECTING BALE (cont.)**

<b>PROBLEM</b>	<b>CAUSE</b>	<b>REMEDY</b>
Bale will NOT fall out of baler when baling cornstalks or haylage.	Bale ramps stop bale from falling.  Baler too narrow at rear opening.	Remove bale ramps.  Increase rear opening to: 45.5" for 2480, 2580, 2680 models 61.5" for 2780, 2880 models
Twine breaks when bale hits ground.	Insufficient number of wraps for size of bale and type of Twine.	Increase number of wraps or reduce the size of the next bale.

# CHAPTER 9

## OPTIONAL FEATURES & ACCESSORIES

### GENERAL INFORMATION

The following Optional Features & Accessories are available for installation on a baler to increase its capabilities. Set-up and assembly, and any required operational information for all kits is provided packaged with each kit of parts.

### STEERING MONITOR KIT

The steering monitor kit assists the operator in forming an even bale when a full windrow is not available. Operation and installation details are provided with the kit.

### BALE KICKER KIT

The bale kicker kit assists bale removal when the bale is completed. Installation details are provided with the kit. The bale kicker kit cannot be used on balers equipped with the bale ramp kit.

### BALE RAMP KIT

The bale ramp kit assists bale removal when the bale is completed. Installation details are provided with the kit. The bale ramp kit cannot be used on balers equipped with the bale kicker kit.

### PICKUP GAUGE WHEELS

The pickup gauge wheel kit provides additional terrain-following support for the pickup as the baler is used. Installation details are provided with the kit.

### CHAIN OILER KIT

The chain oiler kit provides automatic oiling of all drive chains as the baler is used. Installation details are provided with the kit.

### CROWDER WHEELS KIT

The crowder wheels kit is available for expanding the pickup width of balers to enable taking in a wider swath of material. The kit contains (two) crowder wheels, mounts and attaching hardware. Installation, operation and adjustment details are provided with the kit. The kit does not fit on balers equipped with the wide pickup option.

### PICKUP HYDRAULIC LIFT KIT

The pickup hydraulic lift kit is available for remote height control of the crop pickup from the tractor. The kit contains a hydraulic cylinder, hydraulic connections and mounting hardware. Installation details are provided with the kit.

### CHEVRONED BELT LACING KIT (2580, 2680 & 2880)

The belt lacing kit (158697) contains a 6" (152 mm) wide alligator-style lacer and two sets of lacing, pins and rivets. The kit is required when it is necessary to repair a baler chevroned bale forming belt. Refer to details in the Service chapter of this manual for using the kit.

### CHEVRONED BELT LACING, PINS & RIVETS (2580, 2680 & 2880)

The lacing, pin & rivets (157183) is ordered to re-supply the 158697 belt lacing kit.

### CHEVRONED BELT DUTCHMAN KIT (2580, 2680 & 2880)

The Dutchman kit (158698) contains (one) 36" (914 mm) long, 6.5" (165 mm) wide section of chevron belt, already laced and ready for splicing. Installation details are provided with the kit.

### MRT BELT LACING KIT (2480 & 2780)

The belt lacing kit (802700) contains a 6" (152 mm) wide clipper vice lacer, (6) #4-1/2 clipper hook cards and a 72" (1829 mm) long piece of nylon-coated stainless steel cable. The kit is required when it is necessary to repair a baler bale forming belt. Refer to details in the Service section of the Care and Maintenance chapter.

### MRT BELT RE-LACING KIT (2480 & 2780)

The belt re-lacing kit (073390) contains the same components as the belt lacing kit (802700) above with the exception of the clipper vice lacer. This kit is available to replace the supplies furnished with the above kit.

## MRT BELT LACING CABLE (2480 & 2780)

The belt lacing cable (094104) is a 7" (178 mm) long piece of nylon-coated stainless steel cable used for rethreading a belt splice. Refer to the instructions in the Service chapter of this manual for using this cable.

A 6' (1.8 m) roll of lacing cable is also available by ordering part number 078112. Instructions are included.

## MRT BELT DUTCHMAN KIT (2480 & 2780)

The Dutchman kit (084384) contains one 36" (914 mm) long, 6" (152 mm) wide section of MRT belt, already laced and ready for splicing. Installation details are provided with the kit.

## SHEAR BOLTS

On 540 RPM shear bolt PTO model balers, replacement Grade L9, 1/4 x 1-1/2" shear bolts are available in packaged quantities of (eight) per package by ordering part number 095141.

On 2580, 2680 and 2880 model balers equipped with the standard width pickup, replacement Grade 8, 1/4 x 1-1/2" shear bolts are available in packaged quantities of (eight) per package by ordering part number 080079.

On earlier 2580, 2680 and 2880 model balers equipped with the wide pickup, replacement Grade 5, 5/16 x 1-1/4" shear bolts are available in packaged quantities of (eight) per package by ordering part number 900013. On later 2580, 2680 and 2880 model balers equipped with the wide pickup, order Gehl part number 127119. See the "Pickup Clutch" section in the Operation chapter.

## SAFETY CHAIN (Fig. 120)

The recommended safety chain for use with these balers can be obtained in kit 803320.

**NOTE:** *If the baler is to be transported on a public highway, a safety chain kit should be obtained and installed following the details in the Transporting chapter.*

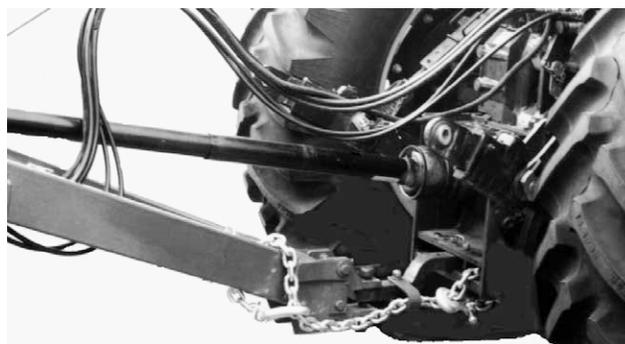

Fig. 120: Safety chain (installed)

## CONNECTOR KIT 119923

This connector kit repairs the male and female ends of the connectors (two wires) that join the ends of the baler harness with the left and right twine feed sensors, end wrap pause sensor, steering monitor sensor, pinch roll count sensor (net wrap models only) and the shuttle return, gate latch sensor & full size bale sensor on the automatic bale control models. The kit also repairs the connectors for the end wrap pause sensor & full size bale sensor on the automatic twine wrap models. Installation details are provided with kit.

## CONNECTOR KIT 119924

This connector kit repairs the male and female ends of the connectors (three wires) that join the ends of the baler harness with the bale size sensor and steering monitor harness. Installation details are provided with the kit.

## CONNECTOR KIT 119925

This connector kit repairs the male and female ends of the connector (two wires, 18 AWG blue and yellow) that joins the ends of the baler harness with the implement harness. Installation details are provided with the kit.

## CONNECTOR KIT 119926

This kit repairs the 6-hole connector to the cab module of the auto bale control system in the tractor power harness. Installation details are provided with the kit.

## CONNECTOR KIT 119927

This connector kit repairs the male and female ends of the connector (two wires, 10 AWG red and black) that joins the ends of the baler harness with the implement

harness for Quikwrap power. Installation details are provided with the kit.

### **CONNECTOR KIT 119928**

This kit repairs the fuse holder in the tractor power harness on both automatic bale control and manual twine control models. Installation details are provided with the kit.

### **CONNECTOR KIT 119929**

This connector kit repairs the end of the baler harness (30 wire connector) that plugs into the implement module. Installation details are provided with the kit.

### **CONNECTOR KIT 158738**

This kit repairs the plug (tractor half of connector ONLY) that joins implement harness to the tractor power harness on the automatic twine control models. Installation details are provided with the kit.

### **CONTACT KIT 158740**

This kit repairs the contacts in the plugs that join the tractor power harness to the implement harness on the automatic twine control. Installation details are provided with the kit.

### **CONNECTOR KIT 158744**

This connector kit repairs the male and female ends of the connectors (four wires) that join the ends of the tractor power harness with the steering monitor tractor module on balers that are equipped with the automatic bale control or the automatic twine control. Installation details are provided with the kit.

### **CONNECTOR KIT 158748**

This kit repairs the plug (baler half of connector ONLY) that joins implement harness to the tractor power harness on the automatic twine control models. Installation details are provided with the kit.

### **CONTACT KIT 159347**

This kit repairs the receptacle (tractor half of connector) that joins the tractor power harness to the implement harness on automatic bale control models.

### **CONTACT KIT 159348**

This kit repairs the contacts in the plugs that join the tractor power harness to the implement harness on automatic bale control models.

### **CONTACT KIT 159349**

This kit repairs the plug (baler half of connector) that joins the implement harness to the tractor power harness on automatic bale control models.

# CHAPTER 10

## DECAL LOCATIONS

### GENERAL INFORMATION

Decal locations information is provided to assist in the proper selection and application of new decals, in the event the original decals become damaged or the machine is repainted. Refer to the listing for the illustration reference number, part number, description and quantity of each decal provided in the kit. Refer to the appropriate illustrations for replacement locations.

**NOTE:** Refer to the Safety chapter for the specific information provided on the various safety decals furnished in the decal kit.

To ensure proper selection for correct replacement decals, compare all of the various close-up location photographs and illustrations to your machine BEFORE starting to refinish the unit. Then circle each pictured decal (applicable to your machine) while checking off its part number in the listing. After you have verified all the decals needed for replacement, set aside unneeded decals for disposal.

### NEW DECAL APPLICATION

Surfaces MUST be free from dirt, dust, grease and other foreign material before applying the new decal. To apply a solid-formed decal, remove the smaller portion of the decal backing paper and apply this part of the exposed adhesive backing to the clean surface while maintaining proper position and alignment. Slowly peel off the other portion of the backing paper while applying hand pressure to smooth out the decal surface.



## CAUTION

**ALWAYS** observe safety precautions shown on decals. If decals become damaged, or if the unit is repainted, replace the decals. If repainting, **BE SURE** that ALL decals from the kit that applies to your machine are affixed to your unit.

#### PAINT NOTICE

Use this list to order paint for refinishing:

906315	One Gal. AG Red
902872	One Qt. Light Grey
906316	6 (12 oz. Spray Cans) AG Red
902874	6 (12 oz. Spray Cans) Light Grey

For a complete decal set, order part 160170 for the 80 Series baler. The following decals, unless otherwise noted, are included in the set:

Ref. No.	Part No.	Description & Quantity
1	060510	Jack Storage Position
2	060511	Jack Lifting Position
3	061832	Belt Tracking Adjustment (2 Places)
4	091444*	DANGER - Rotating Drive Line
5	093366	Store Manual Here
6	093367	WARNING - Owner's Responsibility & Read Manual
7	093373	WARNING - General Safety
8	093458	WARNING - Rotating Wrench
9	093459	WARNING - Reservoir Contamination
10	093461	DANGER - Belt Entanglement
11	093462	DANGER - No Manual Feed (2 Places)
12	093465*	WARNING - 1000 RPM
	093466*	WARNING - 540 RPM
13	093653	WARNING - Rotating Drive Line
14	094914	GEHL 5 x 23-1/2" (127 x 597 mm) (Front)
15	094962	Colorbar 13-1/2" (343 mm) (1 on Each Side)
16	112981	Oil Level Indicator
17	113340	Reservoir Maintenance
18	119554	DANGER - Moving Tailgate (2 Places)
19	120484	Twine Routing (1 on Each Side)
20	122617*	GEHL (1 on Each Side)
21	145216*	Red Reflector Strip (2 Places)
22	153357	Reversing Wrench
23	143007*	DANGER - Shield Missing
24	156417	Tailgate Lock (2 Places)
25	156966*	Bale Size Indicator
26	157763	2480
	157765	2580
	157766	2680
	157768	2780
	157769	2880
27	158154	Lubrication
28	158221	Lubrication
29	158291*	Silage (2 Places)
30	158564*	Twine Position (Field-Installed Only)
31	158292	Variable Open Throat (2 Places)
32	163941	WARNING - Mandatory Safety Shutdown
33	163942	WARNING - Crush Hazard
34	163952	Belt Tension (2 Places)
35	163957	WARNING - Keep Hands Out (5 Places)
36	163962*	DANGER - Keep Hands Out (2 Places)
37	171579	Important

\* Not included in decal kit; order individually as needed

**NOTE:** Order part number 126757 for 10 ft. (3 m) roll of replacement striping.

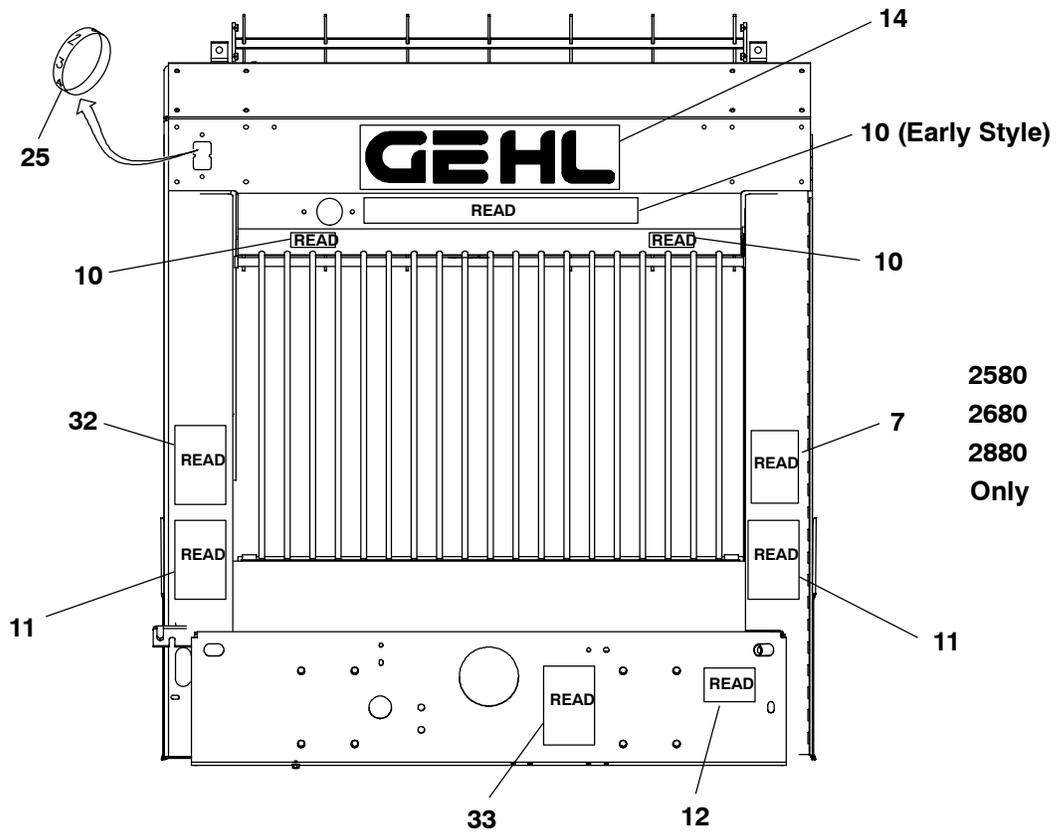
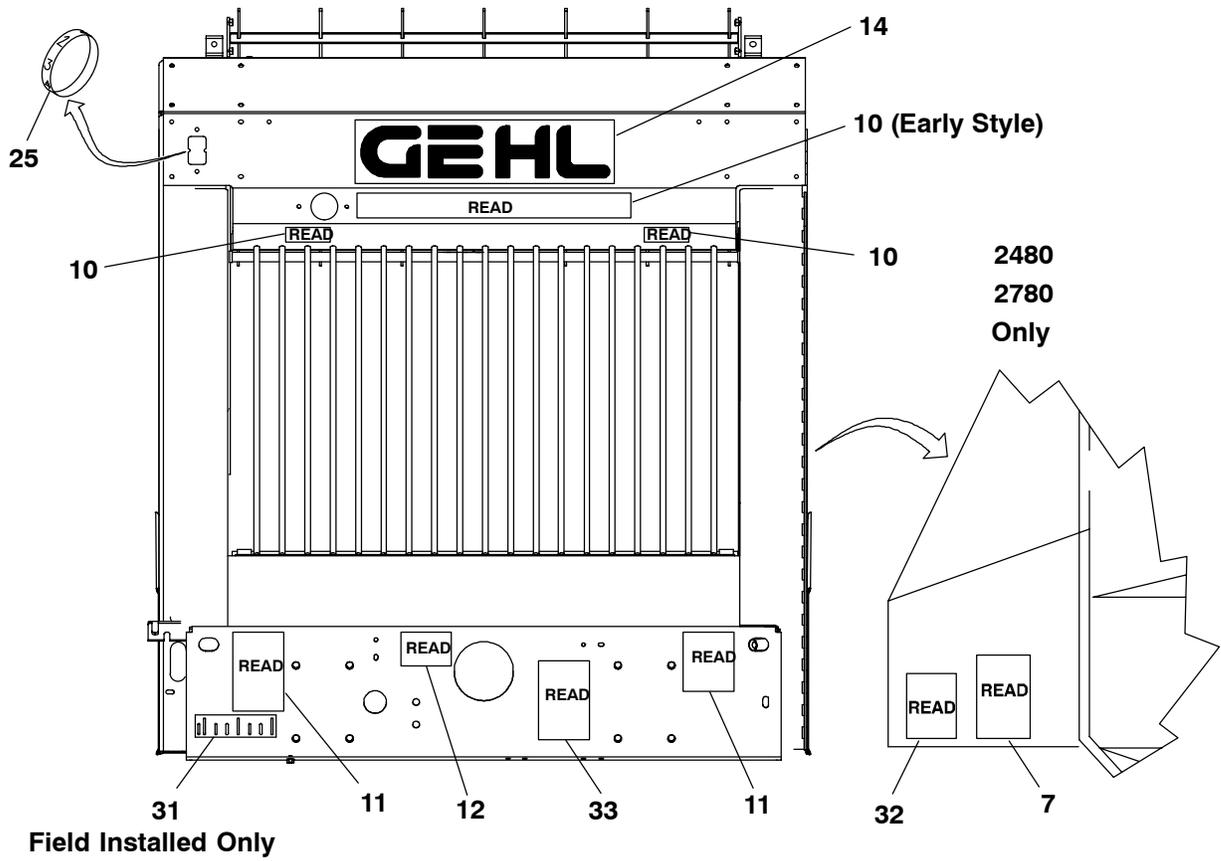

## Chapter 10 - Decal Locations

**NOTE:** *The following is a duplicated listing of the decals from a previous page. It is provided for your convenience when selecting decals from the appropriate illustrations.*

For a complete decal set, order Part Number 160170 for the 80 Series baler. The following decals, unless otherwise noted, are included in the set:

### Ref. Part

#### No. No. Description & Quantity

1	060510	Jack Storage Position
2	060511	Jack Lifting Position
3	061832	Belt Tracking Adjustment (2 Places)
4	091444*	DANGER - Rotating Drive Line
5	093366	Store Manual Here
6	093367	WARNING - Owner's Responsibility & Read Manual
7	093373	WARNING - General Safety
8	093458	WARNING - Rotating Wrench
9	093459	WARNING - Reservoir Contamination
10	124982	WARNING - Pinch Point (2 Places)
	093461	DANGER - Belt Entanglement (Early Style)
11	093462	DANGER - No Manual Feed (2 Places)
12	093465*	WARNING - 1000 RPM
	093466*	WARNING - 540 RPM
13	093653	WARNING - Rotating Drive Line
14	094914	GEHL 5 x 23-1/2" (127 x 597 mm) (Front)
15	094962	Colorbar 13-1/2" (343 mm) (1 on Each Side)

16	112981	Oil Level Indicator
17	113340	Reservoir Maintenance
18	119554	DANGER - Moving Tailgate (2 Places)
19	120484	Twine Routing (1 on Each Side)
20	122617*	GEHL (1 on Each Side)
21	145216*	Red Reflector Strip (2 Places)
22	153357	Reversing Wrench
23	143007*	DANGER - Shield Missing
24	156417	Tailgate Lock (2 Places)
25	156966*	Bale Size Indicator
26	157763	2480
	157765	2580
	157766	2680
	157768	2780
	157769	2880
27	158154	Lubrication
28	158221	Lubrication
29	158291*	Silage (2 Places)
30	158292	Variable Open Throat (2 Places)
31	158564*	Twine Position (Field Installed Only)
32	163941	WARNING - Mandatory Safety Shutdown
33	163942	WARNING - Crush Hazard
34	163952	Belt Tension
35	163957	WARNING - Keep Hands Out (5 Places)
36	163962*	DANGER - Keep Hands Out (2 Places)
37	171579	Important

\* Not included in decal kit; order individually as needed

**NOTE:** *Order Part Number 126757 for 10 ft. (3 m) roll of replacement striping.*

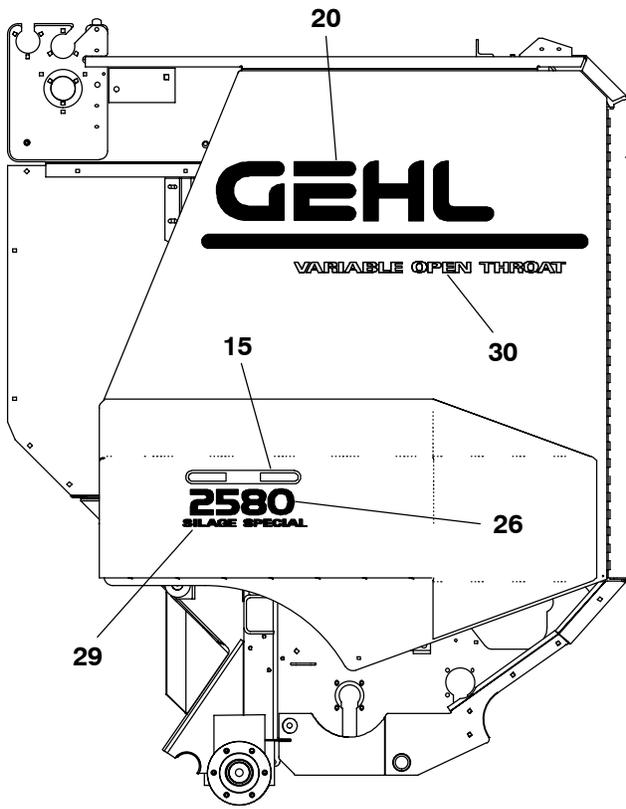

Right Side

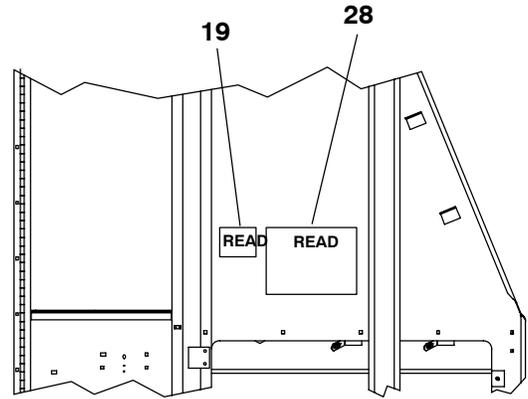

Inside Door

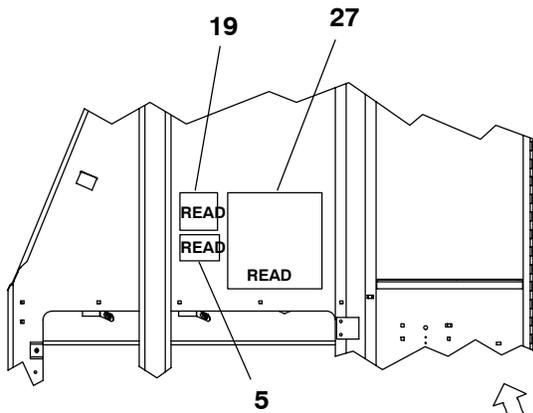

Inside Door

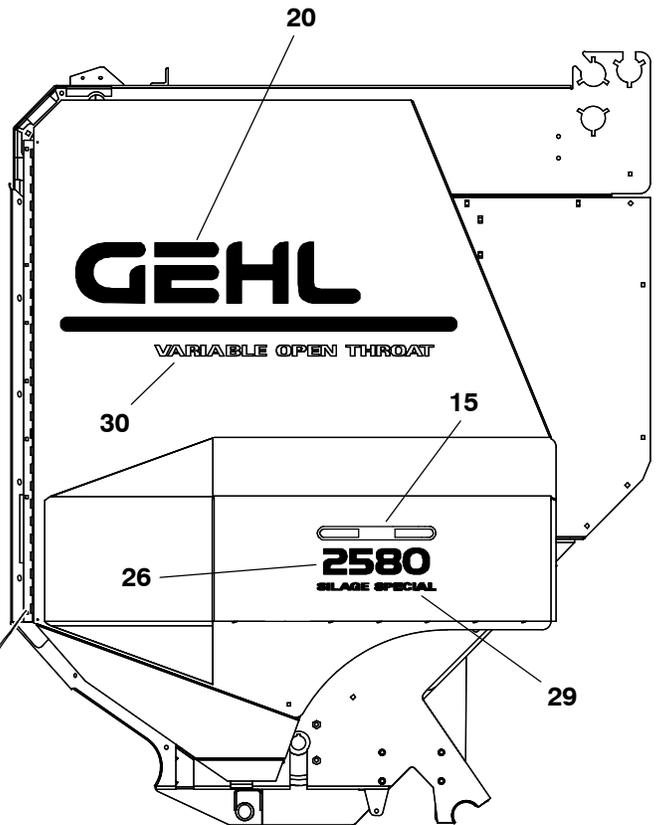

Left Side

**Chapter 10 - Decal Locations**

**NOTE:** *The following is a duplicated listing of the decals from a previous page. It is provided for your convenience when selecting decals from the appropriate illustrations.*

For a complete decal set, order Part Number 160170 for the 80 Series Baler. The following decals, unless otherwise noted, are included in the set:

**Ref. Part**

**No. No. Description & Quantity**

1	060510	Jack Storage Position
2	060511	Jack Lifting Position
3	061832	Belt Tracking Adjustment (2 Places)
4	091444*	DANGER - Rotating Drive Line
5	093366	Store Manual Here
6	093367	WARNING - Owner's Responsibility & Read Manual
7	093373	WARNING - General Safety
8	093458	WARNING - Rotating Wrench
9	093459	WARNING - Reservoir Contamination
10	124982	WARNING - Pinch Point (2 Places)
	093461	DANGER - Belt Entanglement (Early Style)
11	093462	DANGER - No Manual Feed (2 Places)
12	093465*	WARNING - 1000 RPM
	093466*	WARNING - 540 RPM
13	093653	WARNING - Rotating Drive Line
14	094914	GEHL 5 x 23-1/2" (127 x 597 mm) (Front)
15	094962	Colorbar 13-1/2" (343 mm) (1 on Each Side)

16	112981	Oil Level Indicator
17	113340	Reservoir Maintenance
18	119554	DANGER - Moving Tailgate (2 Places)
19	120484	Twine Routing (1 on Each Side)
20	122617*	GEHL (1 on Each Side)
21	145216*	Red Reflector Strip (2 Places)
22	153357	Reversing Wrench
23	143007*	DANGER - Shield Missing
24	156417	Tailgate Lock (2 Places)
25	156966*	Bale Size Indicator
26	157763	2480
	157765	2580
	157766	2680
	157768	2780
	157769	2880
27	158154	Lubrication
28	158221	Lubrication
29	158291*	Silage (2 Places)
30	158292	Variable Open Throat (2 Places)
31	158564*	Twine Position (Field Installed Only)
32	163941	WARNING - Mandatory Safety Shutdown
33	163942	WARNING - Crush Hazard
34	163952	Belt Tension
35	163957	WARNING - Keep Hands Out (5 Places)
36	163962*	DANGER - Keep Hands Out (2 Places)
37	171579	Important

\* Not included in decal kit; order individually as needed

**NOTE:** *Order Part Number 126757 for 10 ft (3 m) roll of replacement striping.*

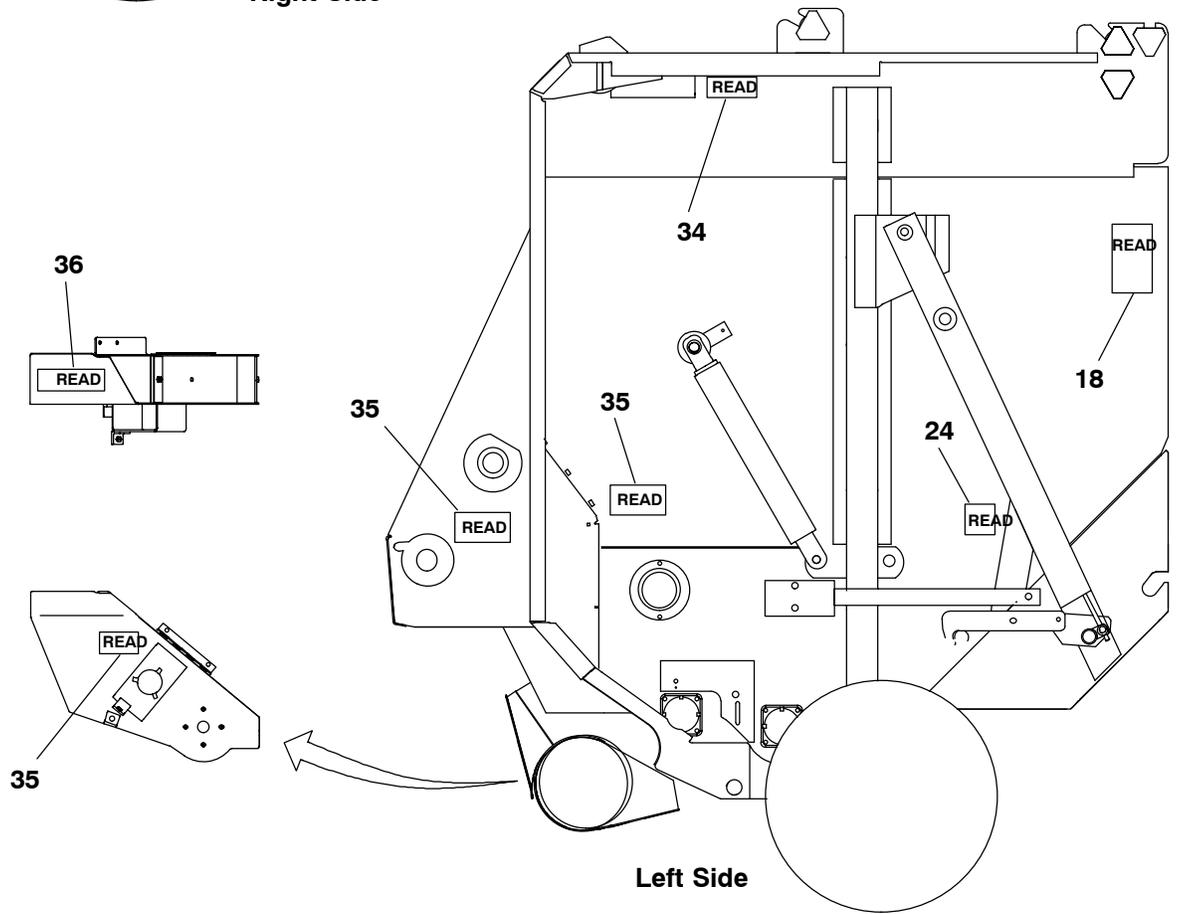
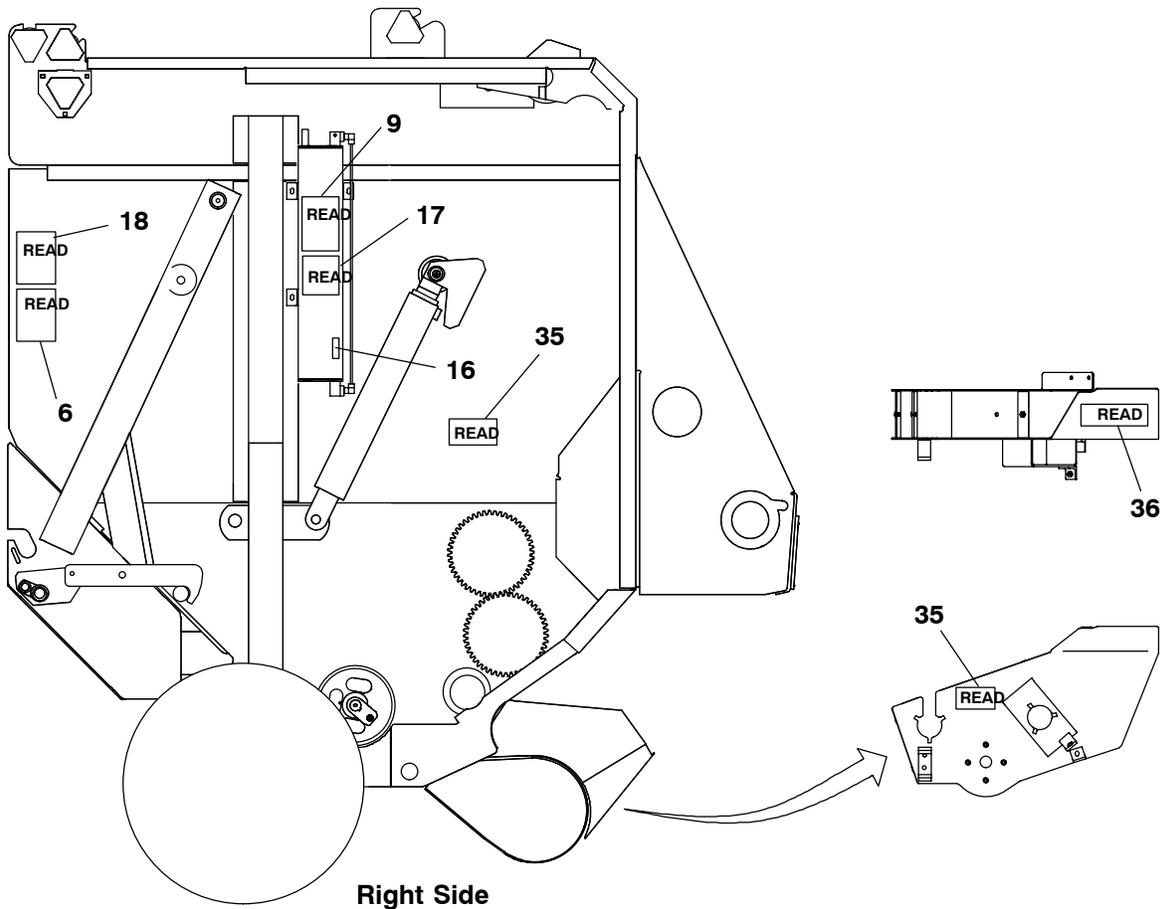

**Chapter 10 - Decal Locations**

**NOTE:** *The following is a duplicated listing of the decals from a previous page. It is provided for your convenience when selecting decals from the appropriate illustrations.*

For a complete decal set, order Part Number 160170 for the 80 Series Baler. The following decals, unless otherwise noted, are included in the set:

Ref. No.	Part No.	Description & Quantity
1	060510	Jack Storage Position
2	060511	Jack Lifting Position
3	061832	Belt Tracking Adjustment (2 Places)
4	091444*	DANGER - Rotating Drive Line
5	093366	Store Manual Here
6	093367	WARNING - Owner's Responsibility & Read Manual
7	093373	WARNING - General Safety
8	093458	WARNING - Rotating Wrench
9	093459	WARNING - Reservoir Contamination
10	093461	DANGER - Belt Entanglement
11	093462	DANGER - No Manual Feed (2 Places)
12	093465*	WARNING - 1000 RPM
	093466*	WARNING - 540 RPM
13	093653	WARNING - Rotating Drive Line
14	094914	GEHL 5 x 23-1/2" (127 x 597 mm) (Front)
15	094962	Colorbar 13-1/2" (343 mm) (1 on Each Side)

16	112981	Oil Level Indicator
17	113340	Reservoir Maintenance
18	119554	DANGER - Moving Tailgate (2 Places)
19	120484	Twine Routing (1 on Each Side)
20	122617*	GEHL (1 on Each Side)
21	145216*	Red Reflector Strip (2 Places)
22	153357	Reversing Wrench
23	143007*	DANGER - Shield Missing
24	156417	Tailgate Lock (2 Places)
25	156966*	Bale Size Indicator
26	157763	2480
	157765	2580
	157766	2680
	157768	2780
	157769	2880
27	158154	Lubrication
28	158221	Lubrication
29	158291*	Silage (2 Places)
30	158564*	Twine Position (Field Installed Only)
31	158292	Variable Open Throat (2 Places)
32	163941	WARNING - Mandatory Safety Shutdown
33	163942	WARNING - Crush Hazard
34	163952	Belt Tension
35	163957	WARNING - Keep Hands Out (5 Places)
36	163962*	DANGER - Keep Hands Out (2 Places)
37	171579	Important

\* Not included in decal kit; order individually as needed

**NOTE:** *Order Part Number 126757 for 10 ft (3 m) roll of replacement striping.*

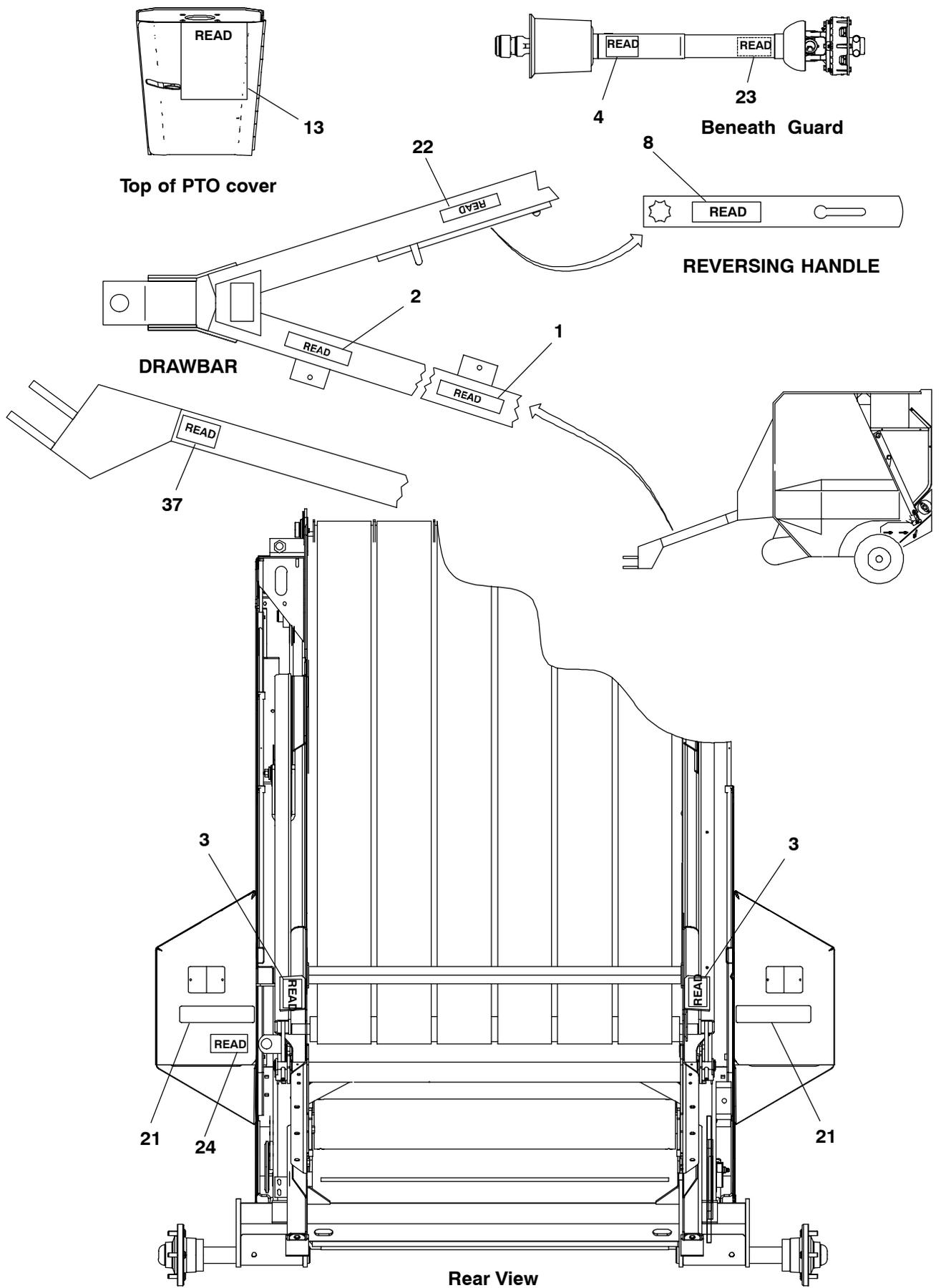



SERVICE EVERY 50 HOURS							
Check tire pressure and wheel nut torque.				Inflate tires to 40 PSI (276 kPa) and torque wheel lugs to 90 ft.-lb. (122 Nm).			
Check universal drive guards.				Lubricate and test that drive shaft rotates freely inside guard.			
Inspect twine knife.				Check sharpness - See "Twine Knife" topic in "Service" section of the Care & Maintenance chapter.			
Readjust scraper position.				Set up to roller - See "Scraper" topic in "Adjustments" section of the Care & Maintenance chapter.			
Inspect pickup overfill clutch.				See "Overfill Clutch" topic in "Adjustments" section of the Care & Maintenance chapter.			
Inspect all roller bearings.				Check for seal failure and overheating.			
Date of Service							

SERVICE EVERY 100 HOURS							
COMPONENT and SERVICE REQUIRED				PROCEDURE and/or CHAPTER TOPIC REFERENCE (Check for Page No. Index)			
Inspect roller chains and drive sprockets.				Replace if worn more than 3% elongation.			
Inspect pickup drive.				Replace belt if it no longer drives pickup.			
Inspect cams and cam bearings.				See "Pickup" topic in "Service" section of the Care & Maintenance chapter.			
Check packing roller to 8" (203 mm) lower roller clearance.				Readjust to 1/4" (6.4 mm) clearance - see "Packing Roller Clearance" topic in "Adjustments" section of the Care & Maintenance chapter.			
Check quality and level of transmission lubrication.				Replace or replenish - see "Lubrication" section of the Care & Maintenance chapter.			
Date of Service							

<b>SERVICE EVERY 200 HOURS (OR END OF SEASON)</b>							
Inspect universal drive joints.				Replace if worn (loud and vibrating).			
Inspect universal joint seals.				Replace if seals worn or damaged.			
Lubricate appropriate grease fittings and repack wheel bearings.				See "Lubrication" section of the Care & Maintenance chapter.			
<b>Date of Service</b>							

# Index

## A

- Activating shuttle locks, 76
- Additional adjustments,
  - new style chain drive twine tie, 57
  - chain adjustment, 57
  - twine arm timing, 57
- Adjustments, 47–60
- Adjustments, lubrication & service, 47–60
- Automatic bale control system, operation, 37
- Automatic twine wrap system, operation, 37

## B

- Balage (high moisture hay), 33
- Bale counter (manual twine wrap system only), 37
- Bale ejection and handling, 38
- Bale forming belts
  - break-in period, 57
  - causes for mis-tracking, 57
  - tracking and alignment, 57
- Bale kicker, adjusting, 59
- Bale size indicator, service, 67
- Bale size visual indicator, 36
- Bale starter, adjusting, 47
- Baler function, 20
- Beginning baling, 33
- Belt routings, 80
- Belts, service, 76

## C

- Chain idlers, adjusting, 47
  - Floor Roller Drive Chains (2580, 2680 & 2880 only), 48
  - Roller Drive (all balers), 47
- Chain oiler
  - installation, 42
  - operation, 61
- Checklists, 5–7
- Clamp jaws, manually opening, 57
- Clamp jaws latch tension, adjusting, 56
- Crowder wheels, adjusting, 52

Printed in U.S.A.

## D

- Decal Application, 96
- Decal Locations, 96–100
- Drawbar connection, 25
- Drawbar flap, 26
- Driveline slip clutch, service, 81

## F

- Fire extinguisher, 23
- Front guard assembly, 21

## G

- Gate end roller, adjusting, 49
- Gate hydraulics, service, 68
- Gate latch lift rods, adjusting, 48
- Gate stops, adjusting, 48
- Grease fitting locations
  - left side, 62
  - optional accessories, 66
  - right side, 64
- Greasing, 62
- Guards, doors & shields, 20
  - hinged guard doors, 20
  - pickup drive guard, 21

## H

- Hitch connections, 25
- Hitchjack, 45
- Hydraulic connections, 27

## I

- Initial field adjustments
  - initial bale size, 32
  - pickup height, 31
  - windguard, 33
- Introduction, 2

## L

- Left-hand twine placement, adjusting, 55
- Locking hitch pin, 24

Lubrication, 61–66

## M

- Maintenance, 104–106
- Mandatory safety shutdown procedure, 8
- Manual twine wrap, operation, 36
- Model & serial no. plate, 2

## O

- Oiling, 61
- Operating options
  - bale ramps, 41
  - crowder wheels, 42
  - hydraulic pickup lift, 42
  - pickup gauge wheels, 42
  - steering monitor, 42
- Operation, 20–46
  - automatic bale control system, 37
  - automatic twine wrap system, 37
  - manual twine wrap, 36
- Optional features, operating, 41
- Optional features & accessories, 93–95
  - bale kicker kit, 93
  - bale ramp kit, 93
  - belt lacing cable (2480 & 2780), 94
  - belt lacing kit (2480 & 2780), 93
  - belt lacing kit (2580, 2680 & 2880), 93
  - belt re-lacing kit (2480 & 2780), 93
  - chain oiler kit, 93
  - connector kit 119923, 94
  - connector kit 119924, 94
  - connector kit 119925, 94
  - connector kit 119926, 94
  - connector kit 119927, 94
  - connector kit 119928, 95
  - connector kit 119929, 95
  - connector kit 158738, 95
  - connector kit 158744, 95
  - connector kit 158748, 95
  - contact kit 158740, 95
  - contact kit 159347, 95
  - contact kit 159348, 95
  - contact kit 159349, 95
  - crowder wheel kit, 93
  - lacing, pins & rivets (2580, 2680 & 2880), 93
  - MRT belt Dutchman kit (2480 & 2780), 94
  - pickup gauge wheels, 93

# Index (cont.)

pickup hydraulic lift kit, 93  
safety chain, 94  
shear bolts, 94  
steering monitor kit, 93  
upper belt Dutchman kit, 93

Overfill clutch, adjusting, 51

Overfill protection, 36

Overload protection, 38

## P

Paint Notice, 96

Pickup, transporting position, 46

Pickup drive, adjusting  
2480 & 2780, 51  
2580, 2680 & 2880, 51

Pickup flotation spring, adjusting  
2480 & 2780, 50  
2580, 2680 & 2880, 50  
Clean Sweep Wide Pickup After  
2001 Model Year, 50

Pickup gauge wheels, adjusting, 52

Pickup height, adjusting  
2480 and 2780, 50  
2580, 2680 & 2880, 50

Pickups, service, 68

Pivoting power in-feed roll spring,  
adjusting, 49

Preparing baler for field operation,  
25–31

Preparing crop to be baled, 31

Preparing the windrow, 31

PTO drivelines, 26

## R

Reflectors, 45

Reversing wrench, 23

## S

Safety, 8–19

Safety chain, 24, 45

Safety equipment, 20

Scraper, adjusting, 52

Sealed bearing replacement, 67

Service, 67–82

Shuttle lock, activating, 76

Shuttle overfill trip bolt, adjusting, 54

Shuttle stops, adjusting, 54

SMV emblem, mounting location, 45

Specifications, 3

Squaring belt shuttle, 54

Start-up, 31

Storage, 83

## T

Table Of Contents, 1

Tailgate cylinder lockout valve, 22

TDC hydraulics system, lubrication,  
61

TDC pressure gauge, 34

TDC pressure relief valve, 36

TDC reservoir air pressure, 70

TDC reservoir draining & repriming,  
72

TDC reservoir fluid level, 71

TDC system  
function, 34  
Service, 70

TDC trip arm positions, 35

TDC valve trip mechanism, adjusting,  
35

Telescoping PTO drive, 21

Tire inflation pressure, 52, 82

Tractor power requirements, 3

Tractor requirements, 25

Transmission  
lubrication, 61  
removal and replacement, 75

Transport lighting, 24, 45

Transport lighting connection, 28

Transporting, 45

Troubleshooting, 84–92

Twine & twine routing, 29

Twine jaws latch position, adjusting,  
56

Twine knife, sharpening, 76

Twine tail length, adjusting, 56

Twine tension, adjusting, 30, 56

Twine tie system, adjusting, 55

Twinebox assemblies, 28

Typical baling cycle, 31

## U

Unplugging baler, 40

## W

Warranty, 2

Wheels & tires, service, 82

Windguard, adjusting, 52

## NOTES

## NOTES

## NOTES

## O-RING TABLE

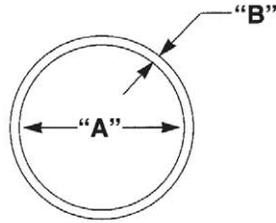

FITTING THREAD SIZE	DIAMETER "A"	DIAMETER "B"	GEHL PART NUMBER
9/16 - 18	0.468	0.078	055897
3/4 - 16	0.644	0.087	055896
7/8 - 14	0.755	0.097	055898
1-1/16 - 12	0.924	0.116	048953
1-5/16 - 12	1.171	0.116	058674
1-5/8 - 12	1.475	0.118	077970

### Recommended Coupling & Adapter Installation Torque Specifications

#### For SAE "O" Ring Boss (Steel)

Size		Ft-Lbs (N·m)	
Dash	Fractional (In.)	Minimum	Maximum
-3	3/16	8 (11)	10 (14)
-4	1/4	14 (19)	16 (22)
-5	5/16	18 (24)	20 (27)
-6	3/8	24 (33)	26 (35)
-8	1/2	50 (68)	60 (81)
-10	5/8	72 (98)	80 (108)
-12	3/4	125 (169)	135 (183)
-14	7/8	160 (217)	180 (244)
-16	1	200 (271)	220 (298)
-20	1-1/4	210 (285)	280 (380)
-24	1-1/2	270 (366)	360 (488)

#### For JIC 37° and 45° (Machined or Flared)

Steel			
Size		Ft-Lbs (N·m)	
Dash	Fractional (In.)	Minimum	Maximum
-4	1/4	10 (14)	11 (15)
-5	5/16	13 (18)	15 (20)
-6	3/8	17 (23)	19 (26)
-8	1/2	34 (46)	38 (52)
-10	5/8	50 (68)	56 (76)
-12	3/4	70 (95)	78 (106)
-16	1	94 (127)	104 (141)
-20	1-1/4	124 (168)	138 (187)
-24	1-1/2	156 (212)	173 (235)
-32	2	219 (297)	243 (330)

# TORQUE SPECIFICATIONS

**NOTE:** Use these torque values when tightening hardware (excluding: locknuts and self-tapping, thread-forming and sheet metal screws) unless specified otherwise.

**All torque values are in Lb.-Ft. except those marked with an \* which are Lb.-In.  
(For metric torque value Nm, multiply Lb.-Ft. value by 1.355 or Lb.-In. value by 0.113)**

Unified National Thread	Grade 2 		Grade 5 		Grade 8 	
	Dry	Lubed	Dry	Lubed	Dry	Lubed
<b>8-32</b> <b>8-36</b>	19* 20*	14* 15*	30* 31*	22* 23*	41* 43*	31* 32*
<b>10-24</b> <b>10-32</b>	27* 31*	21* 23*	43* 49*	32* 36*	60* 68*	45* 51*
<b>1/4-20</b> <b>1/4-28</b>	66* 76*	50* 56*	9 10	75* 86*	12 14	9 10
<b>5/16-18</b> <b>5/16-24</b>	11 12	9	17 19	13 14	25	18 20
<b>3/8-16</b> <b>3/8-24</b>	20 23	15 17	30 35	23 25	45 50	35
<b>7/16-14</b> <b>7/16-20</b>	32 36	24 27	50 55	35 40	70 80	55 60
<b>1/2-13</b> <b>1/2-20</b>	50 55	35 40	75 90	55 65	110 120	80 90
<b>9/16-12</b> <b>9/16-18</b>	70 80	55 60	110 120	80 90	150 170	110 130
<b>5/8-11</b> <b>5/8-18</b>	100 110	75 85	150 180	110 130	220 240	170 180
<b>3/4-10</b> <b>3/4-16</b>	175 200	130 150	260 300	200 220	380 420	280 320
<b>7/8-9</b> <b>7/8-14</b>	170 180	125 140	430 470	320 360	600 660	460 500
<b>1-8</b> <b>1-14</b>	250 270	190 210	640 710	480 530	900 1000	680 740
Metric Course Thread	Grade 8.8 		Grade 10.9 		Grade 12.9 	
	Dry	Lubed	Dry	Lubed	Dry	Lubed
<b>M6-1</b>	8	6	11	8	13.5	10
<b>M8-1.25</b>	19	14	27	20	32.5	24
<b>M10-1.5</b>	37.5	28	53	39	64	47
<b>M12-1.75</b>	65	48	91.5	67.5	111.5	82
<b>M14-2</b>	103.5	76.5	145.5	108	176.5	131
<b>M16-2</b>	158.5	117.5	223.5	165.5	271	200



# **WARNING**



**This Operator's Manual is  
provided for operator use.**

**DO NOT REMOVE  
FROM THIS MACHINE.**

**DO NOT start, operate or work on this machine  
until you have carefully read and thoroughly  
understand the contents of this manual.**

**Failure to follow safety, operating and  
maintenance instructions could result in  
serious injury to the operator or bystanders,  
poor operation, and costly breakdowns.**

**If you have any questions on proper operation,  
adjustment or maintenance of this machine,  
contact your dealer or the Gehl Company  
Service Department before starting or  
continuing operation.**

# **GEHL**®

**Gehl Company, 143 Water Street, P.O. Box 179, West Bend, WI 53095-0179 U.S.A.  
([www.gehl.com](http://www.gehl.com))**