

SL7600 SL7800 SKID STEER LOADER

Form No.
908274
English



OPERATOR'S MANUAL

GEHL[®]

 Gehl Company, in cooperation with the American Society of Agricultural Engineers and the Society of Automotive Engineers, has adopted this Safety Alert Symbol to pinpoint precautions which, if not properly followed, can create a safety hazard. When you see this symbol in this manual or on the machine itself, you are reminded to **BE ALERT!** Your personal safety is involved!

 Operators must have instructions before running the machine. Untrained operators can cause injury or death.

CORRECT



 Read Operator's Manual before using machine.

CORRECT

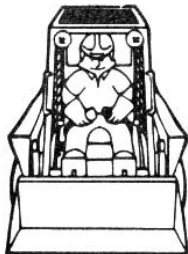

 Always fasten seatbelt snugly. Always keep feet on the floor/pedals when operating loader.

WRONG

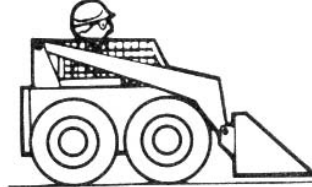

 Never use loader without ROPS/FOPS. Never modify the ROPS/FOPS structure.

WRONG



 Never use the loader to lift personnel.

WRONG



 Do not use loader around explosive dust or gas, or where exhaust can contact flammable material.

SL7600 and SL7800 Skid Steer Loader Operator's Manual

TABLE OF CONTENTS

Introduction	1
Safety	5
Controls And Safety Equipment.	15
Operation	34
Service	45
Troubleshooting	63
Maintenance Schedule	71
Specifications	75
Index	81
Torque Specifications	83
Warranty	84

Loader Model Number	
Loader Serial Number	
Engine Serial Number	

All-Tach, Hydraloc and Hydraglide are trademarks of Gehl Company.
Gehl and Powerview are registered trademarks of Gehl Company.

INTRODUCTION

This Operator's Manual gives the owner/operator information about maintaining and servicing SL7600 and SL7800 skid steer loader models. More importantly, this manual provides an operating plan for safe and proper use of the machine. Major points of safe operation are detailed in the *Safety* chapter of this manual.

We ask that you read and understand the contents of this manual completely and become familiar with your new machine before operating it. See your authorized Gehl dealer if you have any questions concerning information in the manual, require extra manuals or for information concerning the availability of manuals in other languages.

Throughout this manual, information is provided set in *italic* type and introduced by the word **Note** or **Important**. Read carefully and comply with the message — it will improve your operating and maintenance efficiency, help avoid breakdowns and damage, and extend your machine's life.

A manual storage box in the operator's compartment holds the Operator's Manual and AEM Safety Manual. Please return the manuals to this box and keep them with the unit at all times. If this machine is resold, we recommend that these manuals be given to the new owner.

The attachments and equipment available for use with this machine have a wide variety of potential applications. Read the manual provided with the attachment to learn how to safely maintain and operate the equipment. Be sure the machine is suitably equipped for the type of work to be performed.

Do not use this machine for any applications or purposes other than those described in this manual or applicable for approved attachments. If the machine is to be used with special attachments or equipment other than those approved by Gehl Company, consult your Gehl dealer. Any person using non-approved attachments or making unauthorized modifications is responsible for the consequences.

The Gehl dealership network stands ready to provide you with any assistance you may require, including providing genuine Gehl service parts. All service parts should be obtained from your Gehl dealer. Give complete information about the part and include the model and serial numbers of your machine. Record these numbers in the space provided on the Table of Contents page, as a handy reference.











































Please be aware that Gehl strives to continuously improve its products and reserves the right to make changes and improvements in the design and construction of any part without incurring the obligation to install such changes on any unit previously delivered.

If this machine was purchased "used," or if the owner's address has changed, please provide your Gehl dealer or Gehl Company Service Department with the owner's name and current address, along with the machine model and serial number. This will allow the registered owner information to be updated, so that the owner can be notified directly in case of an important product issue, such as a safety update program.

Model Identification



Control/Indicator Symbols

 Power Off	 Power On	 Engine Start	 Battery Charge	 Electrical Power
 Worklight w/Flasher	 Worklight	 Safety Alert	 Hazard Flasher	 Seatbelt - Lap Only
 Horn	 Read Operator's Manual	 Volume - Full	 Volume - Half Full	 Volume - Empty
H-L High - Low	N Neutral	F Forward	R Reverse	(P) Parking Brake
 Engine Air Filter	 Engine Oil	 Engine Oil Filter	 Engine Oil Pressure	 Fuel Filter
 Engine Coolant Temperature	 Hydraulic System	 Hydraulic Oil Temperature	 Hydraulic Oil Filter	 Grease Lubrication Point
 Pre-Heat	 Diesel Fuel	 Chaincase Oil	 Clockwise Rotation	 Counterclockwise Rotation
 Fast	 Slow	 Ride Control	 Power Hitch	 Bucket - Float
 Bucket - Rollback	 Bucket - Dump	 Bucket - Lower	 Bucket - Raise	 Service Hours
 Lift Point	 Tie-Down			

SAFETY



This safety alert symbol means Attention! Become alert! Your safety is involved! It stresses an attitude of “Heads Up for Safety” and can be found throughout this Operator’s Manual and on the decals on the machine.

Before operating this machine, read and study the following safety information. In addition, be sure that everyone who operates or works with this machine, whether family member or employee, is familiar with these safety precautions. It is essential to have competent and careful operators, who are not physically or mentally impaired, and who are thoroughly trained in the safe operation of the machine and the handling of loads. It is recommended that the operator be capable of obtaining a valid motor vehicle operator’s license.

The use of skid steer loaders is subject to certain hazards that cannot be eliminated by mechanical means, but only by exercising intelligence, care and common sense. Such hazards include, but are not limited to, hillside operation, overloading, instability of the load, poor maintenance and using the equipment for a purpose for which it is not intended or designed.

Gehl ALWAYS considers the operator’s safety when designing its machinery and guards exposed moving parts for the operator’s protection. However, some areas cannot be guarded or shielded in order to assure proper operation. Furthermore, this Operator’s Manual and the decals on the machine warn of additional hazards and they should be read and observed closely.

Some photographs in this manual may show doors, guards and shields open or removed for illustrative purposes only. Be sure that all doors, guards and shields are in their proper operating positions before starting the engine to operate the unit.

Different applications may require optional safety equipment, such as a back-up alarm, horn, mirror, strobe light or an impact-resistant front door. Be sure you know the job site hazards and equip your machine as needed.



DANGER “DANGER” indicates an imminently hazardous situation which, if not avoided, will result in death or serious injury.



WARNING “WARNING” indicates a potentially hazardous situation which, if not avoided, could result in death or serious injury.



CAUTION “CAUTION” indicates a potentially hazardous situation which, if not avoided may result in minor or moderate injury. May also alert against unsafe practices.

Mandatory Safety Shutdown Procedure

Before cleaning, adjusting, lubricating, servicing the unit or leaving it unattended:

1. Move the drive control handle(s) to the neutral position.
2. Lower the lift arm and attachment completely. If the lift arm *must* be left in the raised position, BE SURE to properly engage the lift arm support device (page 17).
3. Move the throttle to the low idle position, shut off the engine and remove the key.
4. Before exiting, move the lift/tilt control(s) to verify that the controls do not cause movement of the lift arm and hitch.

Safety Reminders

Before Starting

- ⤿ Do not modify the ROPS/FOPS unless instructed to do so in installation instructions. Modifications such as welding, drilling or cutting can weaken the structure and reduce the protection it provides. A damaged ROPS/FOPS cannot be repaired — it must be replaced.
- ⤿ To ensure safe operation, replace damaged or worn-out parts with genuine Gehl service parts.
- ⤿ Gehl skid steer loaders are designed and intended to be used only with Gehl attachments or approved referral attachments. Gehl cannot be responsible for operator safety if the loader is used with a non-approved attachment.
- ⤿ Remove all trash and debris from the machine each day, especially in the engine compartment, to minimize the risk of fire.
- ⤿ Always face the loader and use the hand holds and steps when getting on and off the loader. Do not jump off the loader.
- ⤿ Never use starting fluid (ether).
- ⤿ Walk around the machine and warn all nearby personnel before starting the machine.
- ⤿ Always perform a daily inspection of the machine before using it. Look for damage, loose or missing parts, leaks, etc.

During Operation

- ⤿ Machine stability is affected by: the load being carried, the height of the load, machine speed, abrupt control movements and driving over uneven terrain. DISREGARDING ANY OF THESE FACTORS CAN CAUSE THE LOADER TO TIP, THROWING THE OPERATOR OUT OF THE SEAT OR LOADER, RESULTING IN DEATH OR SERIOUS INJURY. Therefore, ALWAYS operate with the seatbelt fastened and the restraint bar lowered. Do not exceed the machine's Rated Operating Load. Carry the load low. Move the controls smoothly and gradually, and operate at speeds appropriate for the conditions.

- Always travel with the heavier end of the loader toward the top of the incline for additional stability when operating on inclines or ramps.
- Do not raise or drop a loaded bucket or fork suddenly. Abrupt movements under load can cause serious instability.
- Never push the lift control into the “float” position with the bucket or attachment loaded or raised, because this will cause the lift arm to lower rapidly.
- Do not drive too close to an excavation or ditch; be sure that the surrounding ground has adequate strength to support the weight of the loader and the load.
- Never carry riders. Do not allow others to ride on the machine or attachments, because they could fall or cause an accident.
- Always look to the rear before backing up the skid steer loader.
- Operate the controls only from the operator’s seat.
- Always keep hands and feet inside the operator’s compartment while operating the machine.
- New operators must operate the loader in an open area away from bystanders. Practice with the controls until the loader can be operated safely and efficiently.
- Exhaust fumes can kill. Do not operate this machine in an enclosed area unless there is adequate ventilation.
- When you park the machine and before you leave the seat, check the restraint bar for proper operation. The restraint bar, when raised, deactivates the lift/tilt controls and auxiliary hydraulics, and applies the parking brake.

Maintenance

- Never attempt to by-pass the keyswitch to start the engine. Use only the jump starting procedure detailed in the *Operation* chapter of this manual.
- Never use your hands to search for hydraulic fluid leaks. Instead, use a piece of paper or cardboard. Escaping fluid under pressure can be invisible and can penetrate the skin and cause serious injury. If any fluid is injected into your skin, see a doctor at once. Injected fluid must be surgically removed by a doctor or gangrene may result.
- Always wear safety glasses with side shields when striking metal against metal. In addition, it is recommended that a softer (chip resistant) material be used to cushion the blow. Failure to heed could lead to serious injury to the eyes or other parts of the body.
- Do not smoke or have any spark producing equipment in the area while filling the fuel tank or while working on the fuel or hydraulic systems.

Potential Hazards

A skid steer loader operator must ALWAYS be conscious of the working environment. Operator actions, the environmental conditions and the job at hand require the full attention of the operator so that safety precautions can be taken.

ALWAYS maintain a safe distance from electric power lines and avoid contact with any electrically charged conductor or gas line. Accidental contact or rupture can result in electrocution or an explosion. Contact the North American One Call Referral System at (888) 258-0808 for the local "Digger's Hotline" number or the proper local authorities for utility line locations BEFORE starting to dig!

Exposure to crystalline silica (found in sand, soil and rocks) has been associated with silicosis, a debilitating and often fatal lung disease. A Hazard Review (Pub. No. 2002-129) by the U.S. National Institute for Occupational Safety and Health (NIOSH) indicates a significant risk of chronic silicosis for workers exposed to inhaled crystalline silica over a working lifetime. NIOSH recommends an exposure limit of 0.05 mg/m³ as a time-weighted average for up to a 10-hr workday during a 40-hr workweek. NIOSH also recommends substituting less hazardous materials when feasible, using respiratory protection and regular medical examinations for exposed workers.

Safety Decals

The skid steer loader has decals that provide safety information and precautions around the loader. These decals must be kept legible. If missing or illegible, they must be replaced promptly. Replacements may be obtained from your Gehl dealer. New equipment must have all decals specified by the manufacturer affixed to their proper place.

New Decal Application

Surfaces must be free of dirt, dust, grease and foreign material before applying the decal. Remove the smaller portion of the decal backing paper and apply the exposed adhesive to the clean surface, maintaining proper position and alignment. Peel the rest of the backing paper and apply hand pressure to smooth out the decal surface. Refer to the following pages for proper decal location. Text decals begin on page 9; no-text decals begin on page 12.

Safety Decals inside the ROPS

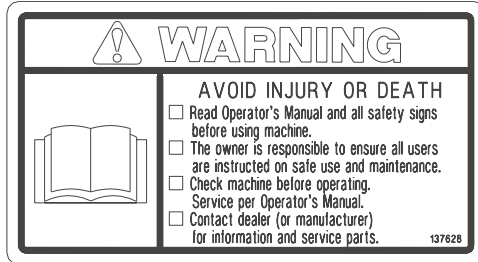

137628 - Located on manual box, behind seat

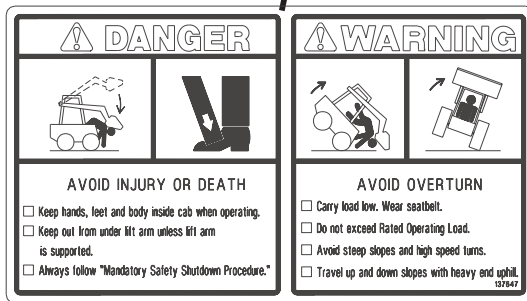
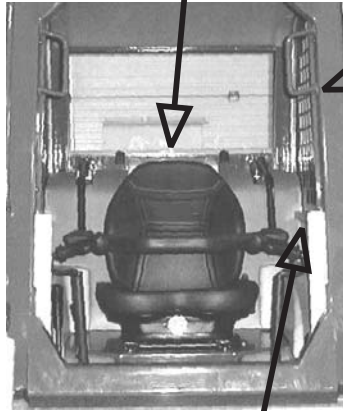

137647 - Located on operator's lower left side

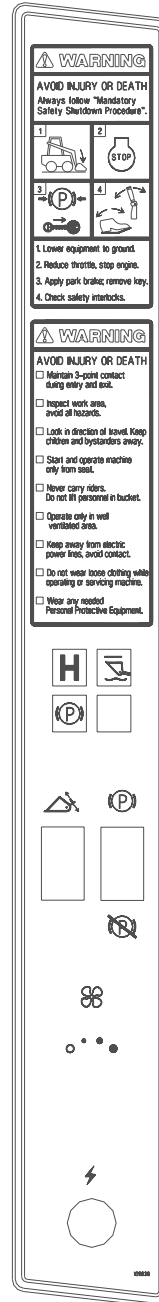

Part of left instrument panel

Safety Decals on the Outside of the Skid Loader

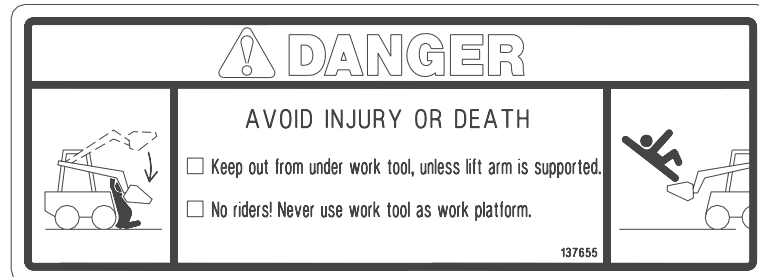

137655 - Located on front of loader

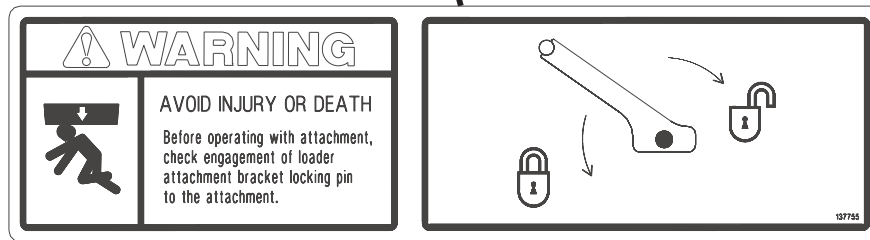

137755 - Located on hitch (manual hitch loaders only)

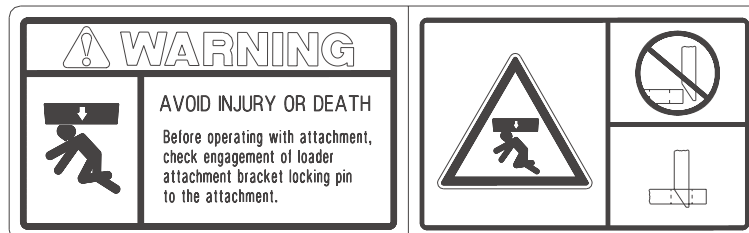



139101 - Located on hitch (power hitch loaders only)



Safety Decals in the Engine Compartment

 WARNING	
AVOID INJURY OR DEATH	
<input type="checkbox"/> Keep safety devices working.	<input type="checkbox"/> Keep guards, screens and windows in place.
<input type="checkbox"/> Jump start per Operator's Manual procedure.	<input type="checkbox"/> Do not smoke while fueling or servicing machine.
<input type="checkbox"/> Clean debris from engine compartment daily to avoid fire. Keep fire extinguisher nearby.	
<input type="checkbox"/> Do not use hands to find hydraulic leaks. Escaping oil under pressure can be invisible and penetrate skin.	
<input type="checkbox"/> Allow radiator to cool before removing cap. Loosen cap slowly to avoid burns.	<small>137657</small>







137657 - Located on radiator

 WARNING

Hose removal or component failure can cause lift arm to drop.
Always use lift arm support device when leaving lift arm raised for service.
To install lift arm support, raise lift arm and have helper:
1. Remove retaining pin and support from storage location;
2. Install support on left lift cylinder with tab facing forward;
3. Secure support with retaining pin.
Then, slowly lower lift arm until braced by support.
<small>137756</small>

137756 - Located on lift arm support device

 WARNING			
	ROTATING FAN	HOT SURFACE	
	Keep hands out or stop engine.	Do not touch hot engine or hydraulic system parts.	
		<small>137658</small>	

137658 - Located on radiator

	jack and needle valve	 WARNING	 AVOID INJURY OR DEATH		jack handle	
			Be sure lock mechanism is securely engaged before working under ROPS/FOPS. Read instructions for use in Operator's Manual.			<small>137760</small>

137760 - Located on rear door

Safety Decals inside the ROPS

	<p>137842 - Located on manual box, behind seat</p> <p>Safety alert: Read Operator's Manual and all safety signs before using machine. The owner is responsible to ensure all users are instructed on safe use and maintenance.</p>
--	---

	<p>Safety alert: Always follow "Mandatory Safety Shutdown Procedure" in Operator's Manual.</p> <ol style="list-style-type: none"> 1 - Lower equipment to ground. 2 - Reduce throttle, stop engine. 3 - Apply parking brake; remove key. 4 - Check safety interlocks. 				
<table border="1" style="width: 100%; border-collapse: collapse;"> <tr> <td style="text-align: center;">1 </td> <td style="text-align: center;">2 </td> </tr> <tr> <td style="text-align: center;">3 </td> <td style="text-align: center;">4 </td> </tr> </table>	1 	2 	3 	4 	
1 	2 				
3 	4 				
<p>137847 - Part of left instrument panel</p>					

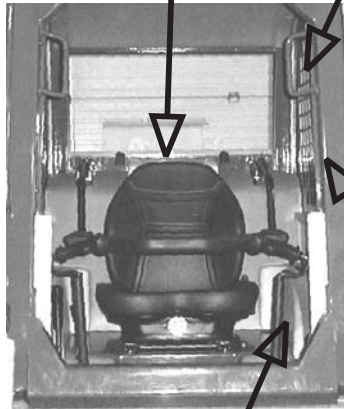







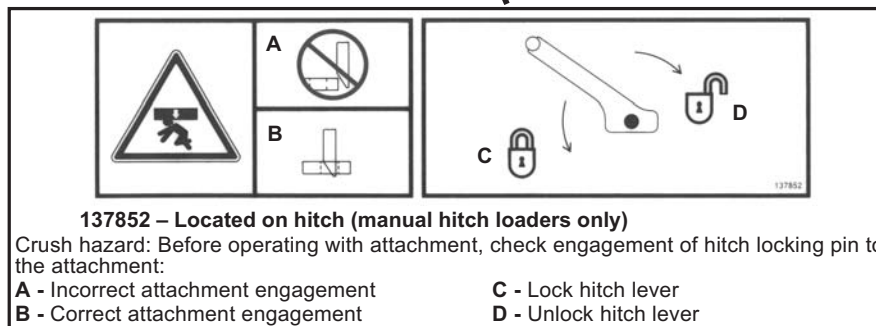
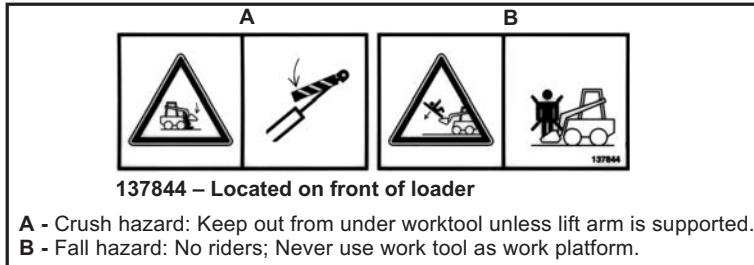

	<p>Safety alert:</p> <p>A - Check machine before operating; Service per Operator's Manual; Contact dealer (or manufacturer) for information and service parts.</p> <p>B - Maintain 3-point contact during entry and exit.</p> <p>C - Inspect work area; Avoid all hazards; Look in direction of travel; Keep children and bystanders away.</p> <p>D - Start and operate machine only from seat.</p> <p>E - Keep away from power lines; Avoid contact.</p> <p>F - Wear any needed Personal Protective Equipment; Do not wear loose clothing while operating or servicing machine.</p>						
<table border="1" style="width: 100%; border-collapse: collapse;"> <tr> <td style="text-align: center;">A </td> <td style="text-align: center;">B </td> </tr> <tr> <td style="text-align: center;">C </td> <td style="text-align: center;">D </td> </tr> <tr> <td style="text-align: center;">E </td> <td style="text-align: center;">F </td> </tr> </table>	A 	B 	C 	D 	E 	F 	
A 	B 						
C 	D 						
E 	F 						
<p>137849 - Part of left instrument panel</p>							

A	B	C	D
<p>137843 - Located on operator's lower left side</p> <p>A - Crush hazard: Keep out from under lift arm unless lift arm is supported.</p> <p>B - Crush hazard: Keep hands, feet and body inside cab when operating.</p> <p>C - Forward tip hazard: Fasten seat belt; Carry load low; Do not exceed Rated Operating Load.</p> <p>D - Side tip hazard: Avoid steep slopes and high speed turns; Travel up and down slopes with heavy end uphill.</p>			

Safety Decals on the Outside of the Skid Loader

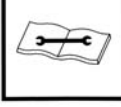

Safety Decals in the Engine Compartment

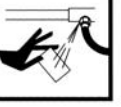
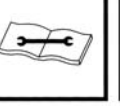
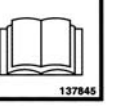
A	B	C	D	E	F
					
					

137845 – Located on radiator

A - Safety alert: Keep safety devices in place and in working order; Keep guards, screens and windows in place.



B - Fire hazard: Do not smoke while fueling or servicing machine; Clean debris from engine compartment daily to avoid fire; Keep fire extinguisher nearby.

C - Run-over hazard: Jump-start per Operator's Manual procedure.





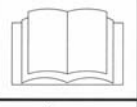

D - Oil injection hazard: Do not use hands to find hydraulic leaks; Escaping oil under pressure can be invisible and penetrate skin; Use a piece of cardboard to find leaks.

E - Burn hazard: Allow radiator to cool before removing cap; Loosen cap slowly to avoid burns.

F - Suffocation hazard: Operate only in a well-ventilated area.

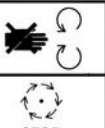
	<p>137853 - Located on lift arm support device</p> <p>Crush hazard: Hose removal or component failure can cause lift arm to drop. Always use lift arm support device when leaving lift arm raised for service.</p>
	
	







A	B
	
	
	

137846 – Located on radiator

A - Rotating fan: Keep hands out or stop engine.

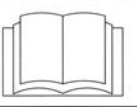
B - Hot surface: Do not touch hot engine or hydraulic system parts.

	jack and needle valve				jack handle	
---	-----------------------	---	---	--	-------------	---

137854 - Located on rear door

Crush hazard: Be sure lock mechanism is securely engaged before working under ROPS/FOPS.

CONTROLS and SAFETY EQUIPMENT

CAUTION Become familiar with and know how to use all safety devices and controls on the skid steer loader before operating it. Know how to stop loader operation before starting it. This Gehl loader is designed and intended to be used only with a Gehl attachment or a Gehl-approved referral attachment or accessory. Gehl cannot be responsible for operator safety if the loader is used with a non-approved attachment.

Guards and Shields

Whenever possible and without affecting loader operation, guards and shields are provided to protect against potentially hazardous areas. In many places, safety decals are also provided to warn of potential hazards and/or to display special operating procedures.

WARNING Read and thoroughly understand all safety decals on the loader before operating it. Do not operate the loader unless all factory-installed guards and shields are properly secured in place.

Operator Restraint Bar

Lower the restraint bar after entering the operator's compartment. The restraint bar is securely anchored to the ROPS. The restraint bar switch and the seat switch form an interlock for the lift arm, tilt, drive and starter circuits (refer to the "Safety Interlock System" topic on page 16 for more information).

WARNING Never defeat the operator restraint bar or seat switch electrically or mechanically. Always wear your seatbelt.

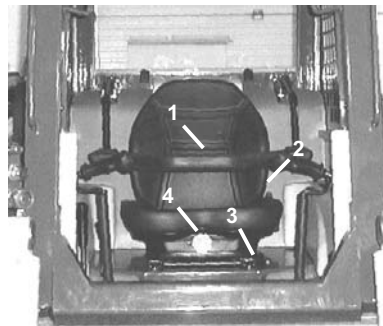

Fig. 1: Operator's Seat

1. Restraint Bar
2. Seatbelt
3. Seat Adjustment Lever
4. Suspension Seat Knob (optional)

Operator's Seat

The seat is mounted on rails for backward or forward repositioning. A spring-loaded latch handle activates the seat adjustment mechanism.

Suspension seat (optional): A weight adjustment knob is provided with this seat for operator comfort.

Battery Disconnect

A battery disconnect switch is located in the rear of the skid loader. Turn the switch to the OFF position to disconnect the battery from the electrical system.



Fig. 2: Battery Disconnect Switch

Safety Interlock System

 **WARNING** NEVER defeat the safety interlock system by mechanically or electrically bypassing any switches, relays or solenoid valves.

An interlock system is provided on the loader for operator safety. Together with solenoid valves, switches and relays, the interlock system:

- » Prevents the engine from starting unless the operator is sitting on the seat and the operator restraint bar is down.
- » Disables the lift arm, auxiliary hydraulics, attachment tilt and wheel drives anytime the operator leaves the seat, turns the keyswitch to OFF or raises the restraint bar.

Testing the Safety Interlock System

Before leaving a parked machine, check the safety interlock system for proper operation:

Restraint Bar

With the engine running, raise the restraint bar. Test each of the controls. There should be no more than a slight movement of the lift arm, hitch and machine. If there is any significant movement, troubleshoot and correct the problem immediately. Contact your dealer if necessary.

Seat Switch

With the engine off and the restraint bar lowered, unfasten your seatbelt. Lift your weight off the seat. Try to start the engine. If the engine starts, turn off the engine, and troubleshoot and correct the problem. Contact your dealer if necessary.

ROPS/FOPS

The ROPS/FOPS (Roll Over/Falling Object Protective Structure) is designed to provide protection for the operator from falling objects and in case the loader tips or rolls over, provided the operator is secured inside the ROPS by the seatbelt and restraint bar.

⚠ WARNING Never operate the loader with the ROPS removed or locked back.

Parking Brake

This skid loader is equipped with a spring-applied, hydraulic-released parking brake. The parking brake engages when the operator lifts the restraint bar, leaves the operator's seat or shuts off the engine. The brake can also be applied manually by using the switch located on the left control panel of the ROPS. A red indicator on the left control panel lights when the parking brake is applied.



Fig. 3: Parking Brake Switch

Horn

Pressing the BLUE button on the left control handle sounds the horn.

Rear Window Emergency Exit

The ROPS rear window has three functions: noise reduction, falling objects barrier and emergency exit.

To use the emergency exit, unlatch the two latches, push out the window and exit.

Lift Arm Support Device

The lift arm support device is used as a cylinder lock to prevent the raised lift arm from unexpectedly lowering. Be sure to engage the support device when the lift arm is raised for service. When the support device is not being used, return it to its storage position. The support device is a safety device that must be kept in proper operating condition at all times. The following steps ensure correct usage:

⚠ WARNING The safest method of engaging the lift arm support device requires two people - one person inside the loader and another person to engage the support device.

Important: *With the keyswitch OFF and the solenoid valve functioning properly, the lift arm will stay raised when the lift control is moved to lower the lift arm. If the valve does not hold the lift arm, lower the lift arm completely. Contact your Gehl dealer immediately to determine why the lift arm lowers while the keyswitch is OFF.*

Engagement

To engage the lift arm support device:

1. Raise the lift arm fully.
2. Stop the engine.
3. Remove the lift arm support device from its storage location on the left rear link.
4. Place the support device on the left lift cylinder with the long end of the support device facing the front of the loader (Fig. 4).
5. Secure the support device with the lock pin.

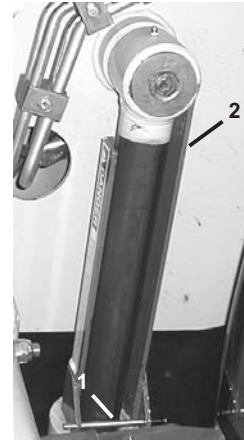

Fig. 4: Lift Arm Support Device Engaged

1. Lock Pin
2. Long End of Support Device

Disengagement

To disengage the lift arm support device:

1. Raise the lift arm completely.
2. Stop the engine.
3. Remove the support device from the lift cylinder and return it to its storage position on the left rear link (Fig. 5).
4. Secure the support device with the lock pin.



Fig. 5: Lift Arm Support Device Stored

Accessory Plug (Optional)

The optional accessory plug is located at the bottom of the left instrument panel.

Heater (Optional)

Loaders with the optional heater have a dial on the left instrument panel to control the fan operation of the heater.

Heater and Air Conditioner (Optional)

Loaders with the combined heater/air conditioner have three controls on the left instrument panel: fan speed, air conditioner on/off and temperature.

- 1. Fan Speed:** Controls the rate at which air exits the vents
- 2. Air Conditioner On/Off:** Turns the air conditioner unit ON and OFF
- 3. Temperature:** Controls the temperature of the air exiting the vents

Hint: *The operator will feel cooler with just the two front vents opened and aimed at the upper body.*

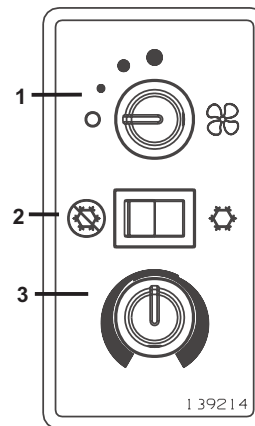

**Fig. 6: Heater/
Air Conditioner Controls**

Speed Control

A right-hand controlled throttle lever is provided on all models for adjusting the engine speed. Move the control forward to increase the engine speed and rearward to decrease the engine speed.

T-Bar and Dual Hand Controls Only: A right-foot operated accelerator pedal is provided to control the engine RPM. The pedal linkage is spring-loaded to return to the adjusted hand-operated throttle setting.

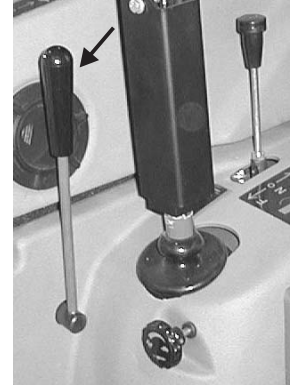

Fig. 7: Throttle Lever

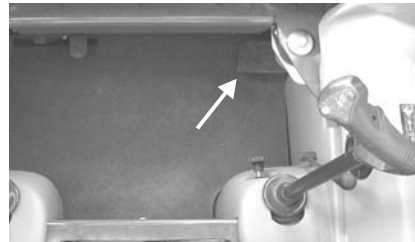

Fig. 8: Foot Pedal (T-Bar & Dual Hand)

Two-Speed Transmission (optional)

Loaders with two-speed transmissions have a **YELLOW** button on the left control handle for shifting between High (H) and Low (L). Shifting to High allows the operator to exceed the standard 8 mph (13 km/h) up to a maximum speed of 14 mph (22.5 km/h).

Note: *Loaders sold to European Union nations can exceed the standard speed up to a maximum speed of 12.4 mph (20 km/h).*

Hydraglide™ Ride Control System (optional)

Loaders with the optional ride control feature have a **BLUE** button on the right control handle for shifting between normal mode and ride control mode. The ride control system provides a smoother ride over uneven surfaces. Press the button once to activate and again to deactivate. The ride control system is automatically deactivated when the machine shuts down.

Note: *The lift arm will drop slightly when ride control is activated.*

Attachment Mounting

Your Gehl loader may be equipped with either a *manual* All-Tach™ attaching mechanism (hitch) or *power* All-Tach™ hitch for mounting a bucket or other attachment.

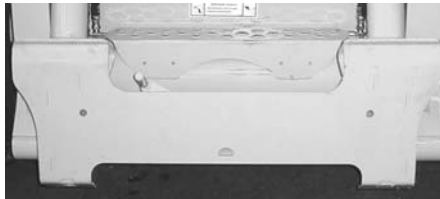

Fig. 9: Manual All-Tach Hitch



Fig. 10: Power All-Tach Hitch

Manual All-Tach Hitch

A manual latch lever engages the latch pins. Rotate the lever all the way to the left to engage the latch pins. Rotate the lever all the way to the right to disengage the latch pins. Refer to page 37 for more information.

⚠ WARNING To prevent unexpected attachment release from the hitch, be sure to secure the latch pins by rotating the lever all the way to the left.

Power All-Tach Hitch

A switch on the left control panel activates the latch pins. Flags on the pins indicated their position; the pin flags will move towards the outside of the hitch when engaging the pins and towards the inside of the hitch when disengaging the pins. Refer to page 37 for more information.

⚠ WARNING To prevent unexpected attachment release from the hitch, be sure the latch pins are secure by verifying that the pin flags have moved as far as possible to the outside of the hitch.

Instrument Panel

The instrument panel contains the following switches and indicators. Symbols on the panel represent various functions and conditions, and are visible only when indicator lamps are on.

Left Panel

Note: Items 1 through 3 are indicator lights which display the following:

1. **Two-Speed High (optional)** – Lights when high speed is engaged.
2. **Parking Brake** – Lights when the parking brake is applied.
3. **Ride Control System (optional)** – Lights when the ride control system is activated.
4. **Parking Brake Switch** – Used to manually apply the parking brake.
5. **Fan (optional)** – Used to manually control the fan for the air conditioner or heater.
6. **Accessory Plug (optional)** – A 12 VDC power outlet.
7. **Power All-Tach Hitch (optional)** – Used to operate the power All-Tach hitch.

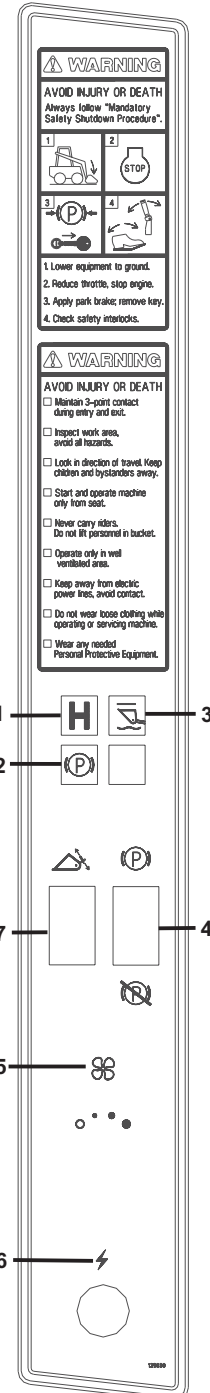

Fig. 11: Left Panel

Right Panel

Note: Items 1 through 8 are indicator lights which display the following:

- 1. Air Filter Restriction (optional)** -Lights if the air filter becomes restricted, warning the operator to stop the engine. Inspect the air cleaner filters and replace if necessary. During normal operation, this indicator should be OFF.
- 2. Engine Coolant Temperature** – Lights if the engine coolant gets too hot, warning the operator to stop the engine. Allow the engine to cool, determine the cause for the high temperature and correct the problem before restarting the engine. During normal operation, this indicator should be OFF.
- 3. Hydraulic Oil Filter Restriction**– Lights if the hydraulic return filter becomes restricted, warning the operator to stop the engine. Allow the engine to cool then change the oil and filter. During normal operation, this indicator should be OFF.
- 4. Hydraulic Oil Temperature** – Lights if the hydraulic oil becomes too hot, warning the operator to stop engine. Allow the hydraulic system to cool and determine the cause of the high temperature. During normal operation, this indicator should be OFF.
- 5. Fasten Seatbelt** – A momentary visual (and audible) indicator to remind the operator to fasten the seatbelt.
- 6. Engine Oil Pressure** – Lights if the engine oil pressure drops too low, warning the operator to immediately stop the engine and determine the cause for the pressure drop. During normal operation, this indicator should be OFF.
- 7. Battery** – Lights if the charging voltage is too high or too low. During normal operation, this indicator should be OFF.
- 8. Preheat Indicator Lamp** – Lights when the preheat is active. During normal operation, this indicator should be OFF.

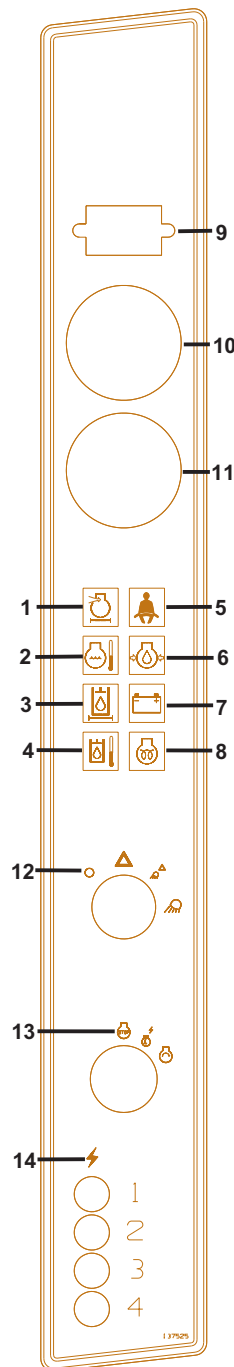

Fig. 12: Right Panel

- 9. Hourmeter** – Indicates the total operating hours of the loader.
- 10. Fuel Level Gauge** – Indicates the amount of fuel in the tank.
- 11. Engine Coolant Temperature Gauge** – Indicates the engine coolant temperature.
- 12. Light Switch** – Controls all the lights (standard and optional) on the loader. Symbols denote the four positions of the light switch. In a clockwise direction these are: Off, Flashers (Hazards), Work Lights with Flashers, and Tail Lights. For the lights to function, the keyswitch must be in the RUN position.
- 13. Keyswitch** – In a clockwise rotation, these positions are:
- Off Position** – With the key vertical (OFF) in the keyswitch, power from the battery is disconnected from the controls and instrument panel electrical circuits. This is the only position the key can be inserted or removed from the keyswitch.
- On or Run Position** – With the key turned one position clockwise (RUN) from the vertical (OFF) position, power from the battery is supplied to all control and instrument panel electrical circuits.
- Start Position** – With the key turned fully clockwise (START) and held in position, the electric starter energizes, starting the engine. Release the key after the engine starts (it returns to the RUN position by itself).
- Note:** *The engine cannot be started unless the operator sits in the seat and the restraint bar is lowered.*
- 14. Circuit Breakers** – Four circuit breakers on the instrument panel protect the loader's electrical circuits.
- Important:** *Do not attempt to defeat the circuit protection by jumping across a circuit breaker or by using a higher amperage circuit breaker.*

T-Bar Controls

Your Gehl loader may be equipped with the T-Bar control option. The left T-Bar controls the drive and the right T-Bar controls the lift/tilt.

Drive Control

Forward, reverse, speed and turning maneuvers are accomplished by movement of the left T-Bar. To go **forward**, push the control forward; for **reverse**, pull the control rearward. To turn **right**, turn the control clockwise; to turn **left**, turn the control counterclockwise. For gradual turns, move the T-Bar slightly forward or rearward. For sharp turns, do not move the control forward or rearward, turn only clockwise or counterclockwise.

Moving the T-Bar farther from neutral increases the speed steadily to the maximum travel speed. Tractive effort decreases as speed increases. To get maximum tractive effort, move the T-Bar only slightly away from the neutral position. The engine will stall if the control is moved too far forward when loading the bucket.



Fig. 13: T-Bar Controls

1. Drive Control
2. Lift/Tilt Control



WARNING Be sure the T-Bar controls are in neutral before starting the engine. Operate the T-Bars gradually and smoothly. Excessive speed and quick T-Bar movements without regard for conditions and circumstances are hazardous and could cause an accident.

Lift/Tilt Control

Moving the lift arm and tilting the attachment are accomplished by movement of the right T-Bar. To **raise** the lift arm, pull the control straight rearward; to **lower** the lift arm, push the control straight forward. To **tilt the attachment downward**, twist the control clockwise; to **tilt the attachment up** or back, twist the control counterclockwise.

Note: *The speed of the lift/tilt motion is directly proportional to the amount of T-Bar movement and engine RPM.*

To place the lift arm in the detent (float) position, push the right T-Bar all the way forward, into the detent. This position allows the lowered lift arm to float while traveling over changing ground conditions.



WARNING

Never push the lift/tilt T-Bar control into the float position with the attachment loaded or raised, because this will cause the lift arm to lower rapidly.

Hand/Foot Controls

Your Gehl loader may be equipped with the hand/foot control option. The handles control the drive and the foot pedals control the lift/tilt.

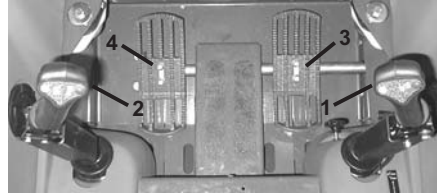

Fig. 14: Hand/Foot Controls

1. Right Drive Control Handle
2. Left Drive Control Handle
3. Tilt Control Pedal
4. Lift Control Pedal

Drive Controls

Forward, reverse, speed and turning maneuvers are accomplished by movement of the control handles. To go **forward**, push both handles forward; for **reverse**, pull both handles rearward. For **turning**, move one handle farther forward or rearward than the other handle. Turn direction is determined by which handle is moved farther forward; to turn left, move the right handle farther forward than the left handle. For sharp turns, move the handles in opposite directions.

Moving the handles farther from neutral increases the speed steadily to the maximum travel speed. Tractive effort decreases as speed increases. To get maximum tractive effort, move the handles only slightly away from the neutral position. The engine will stall if the control is moved too far when loading the bucket.



WARNING Be sure the controls are in neutral before starting the engine. Operate the controls gradually and smoothly. Excessive speed and quick control movements without regard for conditions and circumstances are hazardous and could cause an accident.

Lift/Tilt Controls

Moving the lift arm and tilting the attachment are accomplished by movement of the foot pedals. The left pedal raises and lowers the lift arm; the right pedal tilts the attachment. To **raise** the lift arm, use your heel to push down on the left pedal; to **lower** the lift arm, use your toes to push down on the left pedal. To **tilt the attachment downward**, use your toes to push down on the right pedal; to **tilt the attachment up** or back, use your heel to push down on the right pedal.

Note: *The speed of the lift/tilt motion is directly proportional to the amount of pedal movement and engine RPM.*

To place the lift arm in the detent (float) position, use your toes to push the left pedal all the way down, into the detent. This position allows the lowered lift arm to float while traveling over changing ground conditions.



WARNING Never push the left pedal into the float position with the attachment loaded or raised, because this will cause the lift arm to lower rapidly.

Dual Hand Controls

Your Gehl loader may be equipped with the dual hand control option. The left handle controls the left side drive and the lift. The right handle controls the right side drive and the tilt.

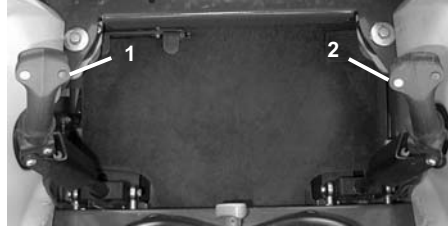



Fig. 15: Dual Hand Controls

1. Left Drive/Lift Control
2. Right Drive/Tilt Control

Drive Controls

Forward, reverse, speed and turning maneuvers are accomplished by pushing and pulling the handles. To go **forward**, push both handles forward; for **reverse**, pull both handles rearward. For **turning**, move one handle farther forward or rearward than the other handle. Turn direction is determined by which handle is moved farther forward; to turn left, move the right handle farther forward than the left handle. For sharp turns, move the handles in opposite directions.

Moving the handles farther from neutral increases the speed steadily to the maximum travel speed. Tractive effort decreases as speed increases. To get maximum tractive effort, move the handles only slightly away from the neutral position. The engine will stall if the control is moved too far when loading the bucket.

 **WARNING** Be sure the controls are in neutral before starting the engine. Operate the controls gradually and smoothly. Excessive speed and quick control movements without regard for conditions and circumstances are hazardous and could cause an accident.

Lift/Tilt Controls

Moving the lift arm and tilting the attachment are accomplished by rotating the control handles. To **raise** the lift arm, rotate the left control up; to **lower** the lift arm, rotate the left control down. To **tilt the attachment downward**, rotate the right control up; to **tilt the attachment up** or back, rotate the right control down..

Note: *The speed of the lift/tilt motion is directly proportional to the amount of control movement and engine RPM.*

To place the lift arm in the detent (float) position, push the left control all the way down, into the detent. This position allows the lowered lift arm to float while traveling over changing ground conditions.



WARNING Never push the lift/tilt control into the float position with the attachment loaded or raised, because this will cause the lift arm to lower rapidly.

Auxiliary Hydraulic Controls

Auxiliary hydraulics are used with an attachment that has a mechanism requiring hydraulic power of its own.

Important: Always be sure the auxiliary hydraulic control is in neutral before starting the loader or removing the auxiliary hydraulic couplers.



Fig. 16: Auxiliary Couplers

1. High Flow Couplers
2. Standard Couplers

Standard Flow Auxiliary Hydraulics

Coupler hookup is located on the left lift arm. “A” port is pressure, “B” port is return when the auxiliary control is in the detent position (refer to page 38). The flow can be manually adjusted from 2 - 29 gpm (7,6-110 L/min) by turning the flow control knob.



Fig. 17: T-Bar and Dual Hand Auxiliary Control

T-Bar and Dual Hand Controlled Loaders: A foot pedal is used to control the direction of oil flow. A stop is provided to lock the foot pedal for continuous operation.

Hand/Foot Controlled Loaders: The right handle controls the direction of oil flow. A locking pin locks it in the up position for continuous operation.



Fig. 18: Hand/ Foot Auxiliary Control

1. Locking Pin

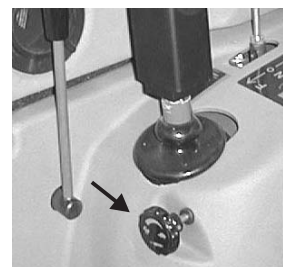

Fig. 19: Standard Flow Control Knob

High Flow Auxiliary Hydraulic Controls

In addition to standard flow auxiliary hydraulic connections, some loaders are shipped with reversible high flow auxiliary hydraulics. Coupler hookup is located on the right lift arm. High flow auxiliary hydraulics are used for operating high oil flow hydraulic attachments (cold planer, snowblower, etc.)

A 3-position control lever is located behind the right control handle. The lever is spring centered with a detent in the forward position for continuous operation.

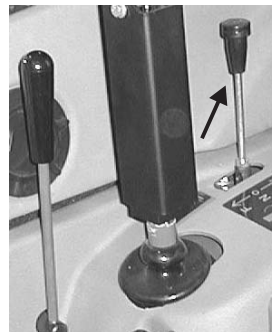

Fig. 20: High Flow Control

NOTES

OPERATION



WARNING Before starting the engine and operating the loader, review and comply with all safety recommendations in the *Safety* chapter of this manual. Know how to stop the loader before starting it. Also, be sure to fasten and properly adjust the seatbelt and lower the operator restraint bar.

Before Starting the Engine

Before starting the engine and running the loader, refer to the *Controls and Safety Equipment* chapter and familiarize yourself with the various operating controls, indicators and safety devices on the loader.

Starting the Engine

The following procedure is recommended for starting the engine:

1. Carefully step up onto the back of the bucket or attachment and grasp the ROPS hand holds to get into the operator's compartment.
2. Fasten the seatbelt and lower the restraint bar.
3. Verify the following:
 - » the lift/tilt, drive and auxiliary controls are in their neutral positions
 - » the parking brake is on.
4. Push the throttle lever forward to half speed.

Note: *When the key is turned to the RUN position, an indicator will light on the instrument panel and a buzzer will sound momentarily to remind you to check that your seatbelt is fastened.*

5. Turn the keyswitch to the RUN position. Wait for the preheat indicator light to go out, then turn the key to the START position. Preheat is automatically controlled and activates if the temperature is 32°F (0°C) or below.

Important: *Do not engage the starter for longer than 15 seconds at a time. Longer use can overheat and damage the starter. If the engine fails to start within 15 seconds, return the key to the OFF position and repeat step 5. Allow the starter to cool for 20 seconds between uses.*

After the engine starts, allow a sufficient warm-up time before attempting to operate the controls.

Important: *If the warning lights do not go off, stop the engine and investigate the cause.*

Cold Starting Procedure



WARNING Do not use starting fluid (ether) with preheat systems. An explosion can result which can cause engine damage, injury or death.

Turn the key to the RUN position. If the preheat light on the instrument panel comes on, wait until it goes out before turning the key to the START position. If the temperature is below 32° F (0° C), try the following to make starting the engine easier:

- » Replace the engine oil with SAE 10W30
- » Make sure the battery is fully charged
- » Install a block heater on the engine.

Let the engine run for a minimum of five minutes to warm the engine and hydraulic fluid before operating the loader.

A block heater is recommended for starting in temperatures of 20°F (-7°C) or lower. See your Gehl dealer for heater options.

Stopping the Loader

The following procedure is the recommended sequence for stopping the loader:

1. Check that the drive control handle(s) is(are) are in neutral position.
2. Lower the lift arm and rest the attachment on the ground.
3. Pull the throttle lever back to the idle position (and/or take your foot off the accelerator pedal for hands-only controlled machines).
4. Turn the keyswitch to the OFF position and remove the key.
5. Raise the restraint bar, unlatch the seatbelt and grasp the hand holds while climbing out of the operator's compartment.

Note: *The skid loader is equipped with a spring-applied automatic parking brake. The parking brake is engaged when the operator lifts the restraint bar, leaves the operator's seat, shuts off the engine or when the brake switch is applied (the top half of the switch is pushed in).*

Parking the Loader

Park the loader away from traffic on level ground. If this is not possible, park the loader across the incline and block the tires to prevent movement.

Jump-starting

If the battery becomes discharged or does not have enough power to start the engine, use jumper cables and the following procedure to jump-start the engine. Remote battery connectors are located at the rear of the loader.



WARNING The only safe method for jump-starting a discharged battery is for two people to perform the following procedure. The second person removes the jumper cables so that the operator does not have to leave the operator's compartment with the engine running.

Never make jumper cable connections directly to the starter solenoid of either engine. Do not start the engine from any position other than the operator's seat and then only after being sure all controls are in neutral.

Closely follow the procedure in order to avoid personal injury. In addition, wear safety glasses to protect your eyes. Avoid leaning over the batteries while jump starting.

Do not jump-start the battery if it is frozen, because it may rupture or explode. Warm the battery to 60°F (16°C) before connecting to a charger.

Note: *Be sure the jumper battery is a 12 volt D.C. battery.*

1. Turn the keyswitches of both machines to OFF. Be sure the machines are in neutral and NOT touching each other.
2. Connect the positive (+) jumper cable to the positive (+) remote battery terminal on the disabled loader first. Do not allow the jumper's positive cable clamps to touch any metal other than the positive (+) remote terminal. Connect the other end of the positive jumper cable to the jumper machine's positive (+) terminal.
3. Connect the negative (-) jumper cable to the jumper machine's negative (-) terminal.
4. Make the final negative (-) jumper cable connection to the disabled negative (-) remote terminal.
5. Be sure the brake switch is engaged and that the controls are in neutral. Start the engine. If it does not start at once, start the jumper machine's engine to avoid excessive drain on the booster battery.
6. After the disabled loader is started and running smoothly, have the second person remove the jumper cables (negative (-) jumper cable first) from the jumper machine's battery and then from the disabled loader while being sure NOT to short the two cables together.

Allow sufficient time for the skid loader alternator to build up a charge in the battery before attempting to operate the loader or shut off the engine.

Changing Attachments

⚠ WARNING To prevent unexpected release of the attachment from the hitch, be sure to properly secure the hitch latch pins by rotating the latch lever all the way to the left (manual All-Tach hitch) or by ensuring that the pin flags are all the way to the outside (power All-Tach hitch)

The skid loader features either a manual or power All-Tach™ attaching mechanism (hitch) for mounting a bucket or other attachment conforming to SAE J2513 standards.

On a manual All-Tach (Fig. 21) hitch, a latch lever engages the latch pins to secure the attachment. On a power All-Tach (Fig. 22) hitch, a switch on the left control panel engages the latch pins to secure the attachment.

Connect Attachment

1. **Manual hitch:** Rotate the latch lever to the right to fully retract the latch pins.

Power hitch: Activate the switch to unlock the hitch and fully retract the latch pins.

2. Start the loader engine and make sure the lift arm is lowered and in contact with the loader frame.
3. Align the loader squarely with the back of the attachment.
4. Tilt the hitch forward until the top edge of the hitch is below the flange on the back side of the attachment and centered between the vertical plates.
5. Slowly drive the loader forward and, at the same time, tilt the hitch back to engage the flange on the back side of the attachment.
6. Stop forward travel when the flange is engaged, but continue to tilt the hitch back to lift the attachment off the ground.
7. **Manual hitch:** Exercise the MANDATORY SAFETY SHUTDOWN PROCEDURE (page 6). Leave the operator's compartment and rotate the latch lever to the left to fully engage the latch pins.

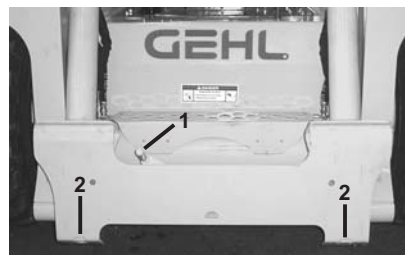

Fig. 21: Manual Hitch - disengaged

1. Latch Lever
2. Latch Pins

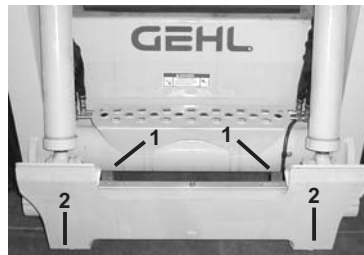

Fig. 22: Power Hitch - disengaged

1. Pin Flags
2. Latch Pins

Power hitch: Activate the switch to lock the hitch and fully engage the latch pins.

Important: *To check that the attachment is properly installed, apply downward pressure to the attachment prior to operating.*

Connect Auxiliary Hydraulic Couplings

Note: *With the engine OFF, key in the ON position and the restraint bar down, the auxiliary hydraulic control can be moved to relieve any pressure in the hydraulic system.*

Standard Auxiliary Hydraulics

Coupler hookup is located on the left lift arm. The top coupler is pressure, the bottom coupler is return when the auxiliary control is in the detent position.

High Flow Auxiliary Hydraulics

Coupler hookup is located on the right lift arm. The top coupler is pressure, the middle coupler is return when the auxiliary control is in the detent position. The bottom coupler is the dedicated case drain.

Remove Attachment

1. Tilt the hitch back until the attachment is off the ground.
2. Exercise the MANDATORY SAFETY SHUTDOWN PROCEDURE (page 6).
3. Relieve any hydraulic pressure in the auxiliary and attachment lines.
 - a. Turn the key ON (do not start the engine).
 - b. With the restraint bar down, move the auxiliary hydraulic control back and forth. This will relieve the pressure in the hydraulic system.
4. With the engine OFF, leave the operator's compartment and disconnect the auxiliary hydraulic hoses.
5. **Manual hitch:** Rotate the hitch's latch lever to the right to fully retract the latch pins.

Power hitch: Turn the key ON (do not start the engine) and activate the switch to unlock the hitch and fully retract the latch pins.

6. Start the engine and be sure that the lift arm is fully lowered and in contact with the loader frame.
7. Tilt the hitch forward and slowly back the loader until the attachment is free from the loader.

Self-Leveling

The feature is designed to keep the attachment level while the lift arm is being raised.

Using a Bucket

 **WARNING** Always maintain a safe distance from electric power lines and avoid contact with any electrically charged conductor or gas line. Accidental contact or rupture can result in electrocution or an explosion. Contact the “Digger’s Hotline” or proper local authorities for utility line locations before starting to dig.

Driving over Rough Terrain

When traveling over rough terrain, drive slowly with the bucket lowered.

Driving on an Incline

When traveling on an incline, the loader must travel with the heavy end pointing uphill.

Digging with a Bucket

Approach the digging site with the lift arm slightly raised and the bucket tilted forward until the edge contacts the ground. Dig into the ground by driving forward and gradually lowering the lift arm.

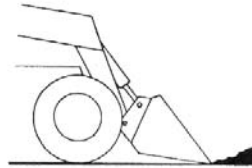

With the bucket filled, tilt the bucket back, back the loader away from the material and rest the lift arm against the loader frame before proceeding to the dumping area.

Fig. 23: Digging

 **WARNING** Always carry the loaded bucket with the lift arm resting on the loader frame. For additional stability when operating on inclines, always travel with the heavier end of the loader toward the top of the incline.

Loading a Bucket

Approach the pile with the lift arm fully lowered and the bucket tilted slightly forward until the edge contacts the ground. Drive forward, lifting the lift arm and tilting back the bucket to fill it. Back away from the pile.

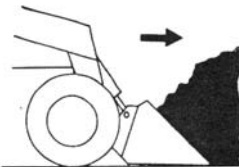

Fig. 24: Loading

Dumping the Load Onto a Pile

Carry a loaded bucket as low as possible until the pile is reached. Gradually stop forward motion and raise the lift arm high enough so that the bucket clears the top of the pile. Then, slowly move the loader ahead to position the bucket to dump the material on top of the pile. Dump the material and then back the loader away while tilting the bucket back and lowering the lift arm.

⚠ WARNING Never push the controls into the float position with the bucket or attachment loaded or raised, because this will cause the lift arm to lower rapidly.

Dumping the Load Into a Box

Carry the loaded bucket low and approach the vehicle or bin. Stop your approach as close to the side of the box as possible while allowing for clearance to raise the lift arm and loaded bucket. Next, raise the lift arm until the bucket clears the top of the box and move the loader ahead to position the bucket over the inside of the box. Dump the material and then back away from the box while tilting the bucket back and lowering the lift arm.



Fig. 25: Dumping Into a Box

Dumping the Load Over an Embankment

⚠ WARNING Do not drive too close to an excavation or ditch. Be sure the surrounding ground has adequate strength to support the weight of the loader and the load.

Carry the loaded bucket as low as possible while traveling to the dumping area. Stop the loader where the bucket extends half-way over the edge of the embankment. Tilt the bucket forward and raise the lift arm to dump the material. Dump the material and then back away from the embankment while tilting the bucket back and lowering the lift arm.

Scraping with a Bucket

For scraping, the loader should be operated in the forward direction. Position the lift arm down against the loader frame. Tilt the bucket cutting edge forward at a slight angle to the surface being scraped. While traveling slowly forward with the bucket in this position, material can flow over the cutting edge and collect inside the bucket.

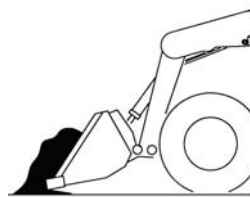

Fig. 26: Scraping

Leveling the Ground

Drive the loader to the far edge of the area to be leveled. Tilt the bucket forward to place the bucket cutting edge at a 30 to 45 degree angle to the surface being leveled. Then place the lift arm into the float position and drive the loader rearward, dragging the dirt and, at the same time, leveling it.

Note: *The float (detent) position for T-bar and dual hand controlled loaders is reached by pushing the right handle all the way forward. For hand/foot controlled loaders, use your toes to push the front of the left pedal all the way down.*

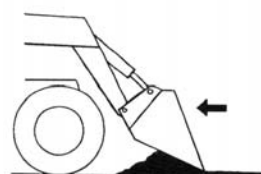

Fig. 27: Leveling the Ground



WARNING

Check that the work area is clear of people and obstacles. Always look in the direction of travel.

Highway Travel

If it becomes necessary to move the loader a long distance, obtain and use a properly rated trailer. For short distance highway travel, attach an SMV (Slow Moving Vehicle) emblem (purchased locally) to the back of the loader. For highway operation, obtain and install dual amber flashers or a strobe light. Check state and local laws and regulations.

Storing the Loader

If your skid loader is to be stored for a long period of time, the following procedure is suggested:

1. Fully inflate the tires.
2. Lubricate all grease zerks.
3. Check all fluid levels and replenish as necessary.
4. Add stabilizer to the fuel per the fuel supplier's recommendations.
5. Remove the battery, charge fully and store in a cool, dry location.
6. Protect against extreme weather conditions such as moisture, sunlight and temperature.

Towing the Loader

The loader must be towed only at slow speed for a short distance (e.g., towing the loader onto a trailer).

The loader can be towed using the front or rear tie downs (Figs. 28 and 29).



WARNING

Be sure the area is clear before towing. The towing chain must be rated at least 1-1/2 times the weight of the loader (see *Specifications* chapter - p. 75).

Transporting the Loader

⚠ WARNING Park the truck or trailer on a level surface. Be sure the vehicle and its ramps have the weight capacity to support the loader. Be sure the vehicle surface and its ramps are clear of debris and slippery material that may reduce traction. Move the loader on and off the vehicle ramp slowly and carefully. Failure to follow these instructions could result in an overturn accident.

Observe all local regulations governing the loading and transporting of equipment. Ensure that the hauling vehicle meets all safety requirements before loading the skid loader.

1. Place blocks at the front and rear of the hauling vehicle's tires.
2. If the loader has an attachment, lift it slightly off the ground.
3. Back the loader slowly and carefully up the ramp onto the vehicle.
4. Lower the loader attachment to the vehicle deck, turn off the engine and remove the key.
5. Fasten the loader to the hauling vehicle at the points indicated by the tie-down decals.
6. Measure the clearance height of the loader and hauling vehicle. Post the clearance height in the cab of the vehicle.



Fig. 28: Front Tie Down



Fig. 29: Rear Tie Down

Lifting the Loader

The loader can be lifted using a single-point or four-point lift kit, which are available from your authorized Gehl dealer.

WARNING

- **Before lifting, check the lift kit for proper installation.**
- **Never allow riders in the operator's compartment (ROPS) while the loader is lifted.**
- **Keep everyone a safe distance away from the loader while it is lifted.**
- **Loader may only be lifted with an empty bucket or empty pallet forks, or with no attachment. Never lift the loader with attachments other than those stated.**

Lift equipment used and its installation is the responsibility of the party conducting the lift. All rigging **MUST** comply with applicable regulations and guidelines.

1. Using suitable lift equipment, hook into the lift eyes (refer to Figs. 30, 31 and 32). Adjust the length of the slings or chains to lift the loader level.

Important: *As needed, use a spreader bar to prevent the slings or chains from rubbing the sides of the ROPS.*

2. Center the hoist over the ROPS. To prevent shock loading of the equipment and excessive swinging of the load, slowly lift the loader off the ground. Perform all movements slowly and gradually.



Fig. 30: Four-Point Front Lift Eye

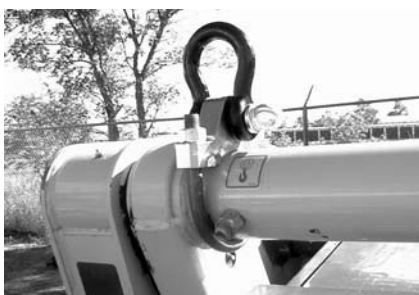

Fig. 31: Four-Point Rear Lift Eye

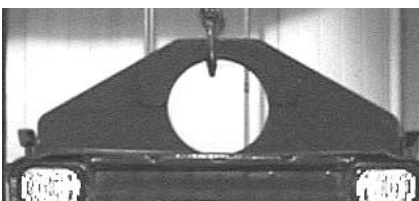

Fig. 32: Single-Point Lift Eye

SERVICE

 **WARNING** Before servicing the machine, unless expressly instructed to the contrary, exercise the MANDATORY SAFETY SHUTDOWN PROCEDURE (page 6).

After service has been performed, be sure to restore all guards, shields and covers to their original positions before resuming loader operation.

This *Service* chapter details procedures for performing routine maintenance checks, adjustments and replacements. Most procedures are referred to in the *Troubleshooting* and *Maintenance Schedule* chapters of this manual. Refer to the *Maintenance Interval Chart* (page 71) for service intervals. Refer to the separate engine manual provided for engine-related adjustments, lubrication and service procedures.

Note: *All service procedures, except those described under the “Dealer Services” topic are owner-operator responsibilities.*

Important: *Always dispose of waste lubricating oils and hydraulic fluids according to local regulations or take to a recycling center for disposal. Do not pour onto the ground or down the drain.*

Dealer Services

The following areas of component service, replacement and adjustments require special tools and knowledge for proper servicing and should be performed only by your authorized Gehl skid steer loader dealer: Hydrostatic Components, Hydraulic System Axial Pump, Valves, Cylinders, Electrical Components (other than the battery, circuit breakers) .

Replacement Parts

Part Description	Gehl Part No.
Air Cleaner Element, Primary	137498
Air Cleaner Element, Secondary	137501
Hydraulic Oil Filter Element	137359
Hydrostatic Oil Filter Element	074830
Engine Oil Filter Element	137500
In-line Fuel Filter	137794
Spin-on Fuel Filter Cartridge	137499
Fresh Air Intake Filter (heater option)	138551
Recirculation Air Filter (heater option)	138545

Note: *Part numbers may change. Your Gehl dealer will always have the latest part numbers.*

Loader Raising Procedure

To raise the skid loader so that all four tires are off the ground, use the procedure below:

⚠ WARNING Do not rely on a jack or hoist to maintain the raised position without additional blocking and supports. Serious personal injury could result from improperly raising or blocking the skid loader.

1. Using a jack or hoist capable of lifting the fully-equipped weight of the loader (with all attached options, except hitch attachments), lift the rear of the loader until the rear tires are off the ground.
2. Stack wooden blocks under the flat part of the loader chassis. They should be parallel to, but not touch, the rear tires (Fig. 33).
3. Slowly lower the loader until its weight rests on the blocks. If the tires still touch the ground, raise the loader again, add more blocks and lower again.
4. Repeat Steps 1 through 3 for the front end. When the procedure is finished, all four tires will be off the ground so they can be removed.

Loader Lowering Procedure

When service or adjustment procedures are complete, the skid loader can be taken down from the raised position. To lower the loader onto its tires:

1. Using a jack or hoist, raise the front of the loader until its weight no longer rests on the front blocks.
2. Carefully remove the blocking under the front of the loader.
3. Slowly lower the loader until the front tires are resting on the ground.
4. Repeat Steps 1 through 3 for the rear of the loader. When the procedure is finished, all four tires will be on the ground and the blocks removed from under the loader.

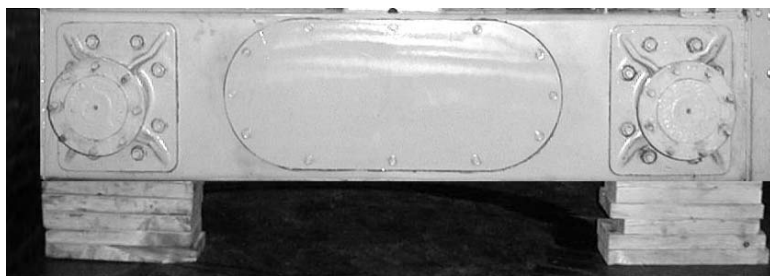

**Fig. 33: Skid Loader Properly Blocked
(Tires and wheels removed to show blocks)**

Engine Compartment Access

Important: Do not raise the lift arm with the engine cover raised.

To open the engine compartment, turn the rear door latch and carefully lower the rear door. Lift the engine cover. The side panels are removed by turning the butterfly bolts and pulling the panels out. The side panels are easier to access if the lift arm is raised and secured (page 17).

Note: The rear door may be stood on.

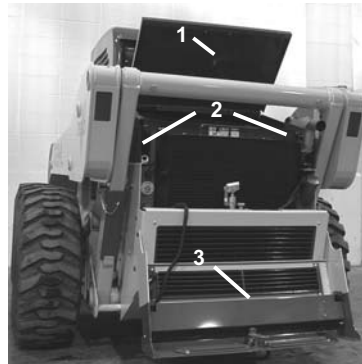

Fig. 35: Engine Compartment Access Doors

1. Engine Cover
2. Side Panels
3. Rear Door

Tilting the ROPS Back

A manual hydraulic pump in the engine compartment is used to tilt the ROPS back. The pump handle is stored on the right side of the compartment. A manual lock mechanism engages to lock the ROPS in a rolled-back position. To tilt the ROPS back, use the following procedure:

1. Remove the two anchor bolts at the front of the ROPS.
2. Place the pump handle in the pump.
3. Tighten the needle valve.
4. Pump until the ROPS is tilted enough that the lock mechanism underneath the right side of the ROPS engages.
5. To lower the ROPS, return the lock mechanism to the unlocked position. Loosen the needle valve and the ROPS will slowly tilt back down. Reinstall the anchor bolts, washers and locknuts.

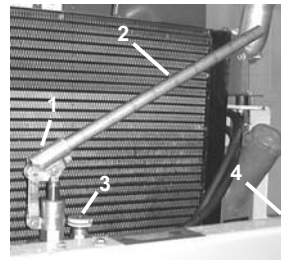

Fig. 34: ROPS Tilt Pump

1. Pump
2. Pump Handle
3. Needle Valve
4. Handle Storage

⚠ WARNING Never operate the loader with the ROPS removed or locked back. Be sure the lock mechanism is securely engaged when the ROPS is tilted back. Be sure to reinstall the anchor bolts, washers and locknuts before resuming loader operation.



Fig. 36: ROPS Lock Mechanism - Engaged

Adjustments

Control Handles

The control handles do not require routine adjustment. Refer to the *Service Manual* for the initial setup procedure.

Fuel Sender

The fuel sender, located on the fuel tank, sends a signal to the fuel gauge indicating the amount of fuel in the fuel tank.

Check the fuel sender periodically to ensure that the mounting screws are tight and that there is no fuel seepage around the gasket. If adjustment is required, apply an RTV or gasket sealant around the gasket when restoring the fuel sender.

Engine Speed Control

The throttle does not require routine adjustment. Refer to the *Service Manual* for the initial setup procedure.

The throttle lever friction pad pressure can be adjusted if the throttle lever does not hold its position. Belleville washers and a lock nut on the throttle lever are used for making this adjustment.

Foreign Material Removal

The loader should be cleared daily of dirt and other foreign materials in the following areas:





- around the rear link and lift cylinder
- at the front of the loader
- on the hitch, especially around the linkage
- around the hydraulic oil level sight gauge
- around the hydraulic oil reservoir breather
- in the engine compartment
- in the operator's compartment

The build-up of foreign materials in these areas can interfere with the operation of the loader, cause component damage or become a fire hazard.

Lubrication

Listed below are the locations, temperature ranges and types of lubricants for this machine. Refer to the separate engine manual for more information regarding engine lubricants, quantities and grades required.

Note: Refer to the specific service sections for detailed information on periodic checking and replenishing of lubricants.

 Hydraulic System Oil	Use Petro Canada HVI60, Mobil DTE 15M or equivalent which contains anti-rust, anti-foam and anti-oxidation additives, and conforms to ISO VG46. Capacity: 15 U.S. gallons (56,8 liters)
 Chaincase Oil	Use hydraulic system oil or SAE grade 15W-40 motor oil. Capacity (each side): 3 U.S. gallons (11,4 liters)
 Grease Fittings	Use lithium based grease
 Engine Oil	Below 32°F (0°C) - Use SAE Grade* 10 or 10W-30 Above 32°F (0°C) - Use SAE Grade* 15W-40 *Service Classification: API - CF-4/CG-4 Capacity: 14.8 U.S. quarts (14 liters)

Refer to Fig. 37 for grease fitting locations. Wipe dirt from the fittings before greasing them to prevent contamination. Replace any missing or damaged fittings. To minimize dirt build-up, avoid excessive greasing.

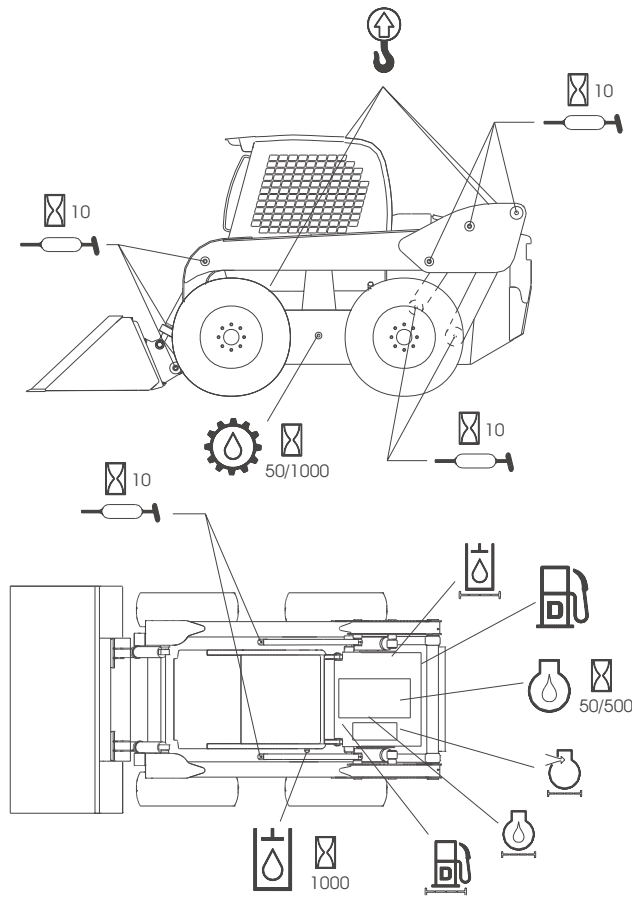

Fig. 37: Service Locations

Lubrication Procedure	10 Hours (or Daily)	250 Hours	500 Hours (or Yearly)
Check Engine Oil Level (p56)	●		
Check Hydraulic Oil Level (p57)	●		
Grease Lift Arm, Hitch, Cylinder Pivots and Latch Pins (p49)	●		
Check Oil Level in Chaincases (p51)		●	
Change Engine Oil and Filter (p56)	□	❖	●
Change Hydrostatic Oil Filter (p57)	□		●
Change Hydraulic Oil Filter (p57)			●
Change Hydraulic Oil (p57)			◆
Change Chaincase Oil (p51)	□		◆

- Perform the initial procedure at 50 hours then at “●” or “◆” intervals.
- ❖ Severe operating conditions.
- ◆ Perform the procedure at 1000 hours.

Chaincases

There is a chaincase on each side of the loader. Refer to the *Maintenance Interval Chart* (page 71) for change intervals. Refer to the “Lubrication” topic (page 49) for information on oil type and quantity.

Checking and Adding Oil

1. Park the loader on a level surface. Stop the engine.
2. Remove the check plug from each chaincase housing. The oil level should be at the plug level or no more than 1/4” below.
3. If the level is low, add fluid through the fill plug until the oil level reaches the edge of the check plug hole. Reinstall the plugs.

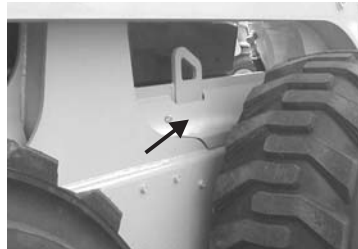

Fig. 38: Front Cover

Draining Oil

1. Park the loader on a level surface or on a sloping surface with the loader facing uphill.
2. Remove the drain plug on each chaincase and drain the oil into a suitable container.
3. Reinstall and tighten the drain plugs.
4. Refill the chaincases at the fill plugs located under the cover at the front of the loader.

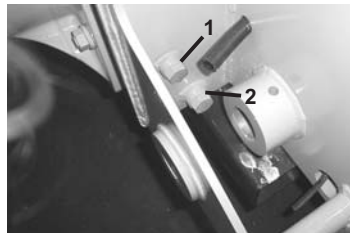

Fig. 39: Check and Drain Plugs

1. Check Plug
2. Drain Plug

Drive Chains

Drive chains are located in the chaincase on each side of the machine. Refer to the *Maintenance Interval Chart* (page 71) for tension check interval.

Check Chain Tension

1. Raise the loader following the “Loader Raising Procedure” (page 46).
2. Rotate each tire by hand. The proper amount of rotation should be 1/8” - 1” (3 - 25 mm) forward and rearward. If the rotation is more than 1” (25 mm) or less than 1/8” (3 mm) in either direction, the chains should be adjusted.

Adjust Chain Tension

1. Raise the loader following the “Loader Raising Procedure” (page 46).
2. Remove the tire from the axle to be adjusted.
3. Loosen (**DO NOT** remove) the bolts holding the axle to the chaincase.
4. **Front Chain Tension** - To tighten the front chain, move the front axle assembly towards the front of the loader. To loosen the chain, move the front axle assembly toward the rear of the loader.

Back Chain Tension - To tighten the back chain, move the rear axle assembly rearward. To loosen the chain, move the rear axle assembly toward the front of the loader.

5. After the proper tension is obtained, retighten the bolts.

Important: *Over-tightening the drive chain will cause premature drive chain and axle sprocket wear.*

6. Reinstall the tire.
7. Repeat Steps 2 through 6 for any axle requiring adjustment.
8. Lower the loader following the “Loader Lowering Procedure” (page 46).

Engine Air Cleaner

Important: Failure to follow proper filter servicing instructions could result in catastrophic engine damage.

The air cleaner consists of an outer (primary) filter element and an inner (secondary) filter element. An air filter restriction indicator for monitoring the condition of the elements is located on the right side of the front of the air cleaner. If the air filter becomes restricted, this indicator turns red to warn the operator that the element(s) require service. Push the reset button located at the end of the indicator after fitting a clean element. For replacement elements, refer to the “Replacement Parts” topic (page 45).

Note: Before replacing the filter element(s), push the reset button on the indicator. Start the engine and adjust the throttle to full speed. If the indicator does not turn red, do **not** replace the element(s).

The outer element should be replaced only when the restriction indicator turns red. The inner element should be replaced every third time the outer element is replaced, unless the outer element is damaged or the inner element is dirty.

Along with a daily check of the restriction indicator, check the air cleaner intake hose and clamps, and the mounting bracket hardware for secureness.

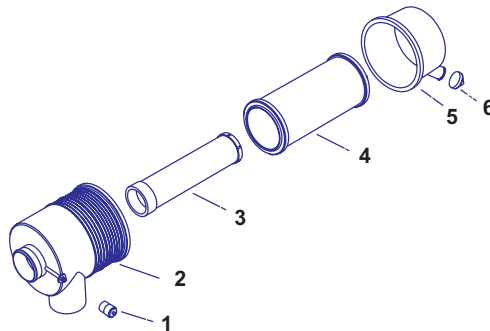

Fig. 40: Dual Element Air Cleaner

- | | |
|--------------------------|-------------------------|
| 1. Restriction Indicator | 4. Outer Filter Element |
| 2. Element Housing | 5. Element Cover |
| 3. Inner Filter Element | 6. Dust Ejector |

Access

1. Open the rear door and engine cover (page 47).
2. Unlatch the three latches on the air cleaner and remove the cover. Clean out any dirt built up in the cover assembly.

Outer Element

1. Carefully pull the outer element out of the housing. Never remove the inner element unless it is to be replaced.
2. Clean out any dirt built up in the housing. Leave the inner element installed during this step to prevent debris from entering the engine intake manifold.
3. Use a trouble light inside the outer element to inspect for spots, pinholes or ruptures. Replace the outer element if any damage is noted. The outer element must be replaced if it is oil- or soot-laden.

Note: *Gehl does not recommend cleaning the outer element.*

Inner Element

Note: *Replace the inner element only if it is dirty or if the outer element has been replaced three times.*

Before removing the inner element from the housing, clean out any dirt built up in the housing. Leave the inner element installed during this step to prevent debris from entering the engine intake manifold. Remove the inner element.

Reinstallation

1. Check the inside of the housing for any damage that may interfere with the elements.
2. Be sure that the element sealing surfaces are clean.
3. Insert the element(s), making sure that they are seated properly.
4. Secure the cover to the housing with the three clamps.
5. Check the hose connections and make sure they are all clamped and tightened properly.
6. Reset the indicator by pressing the reset button.

Engine Service

Refer to the *Maintenance Interval Chart* (page 71) for change intervals. Refer to the “Replacement Parts” topic (page 45) for replacement part numbers.

Check Engine Mounting Hardware

All bolts that secure the engine mounting brackets to the engine and the loader frame should be checked and re-torqued as necessary. Refer to the *Torque Specifications Chart* (page 83) for torque information.

⚠ WARNING Allow hot engine and hydraulic system components to cool before servicing.

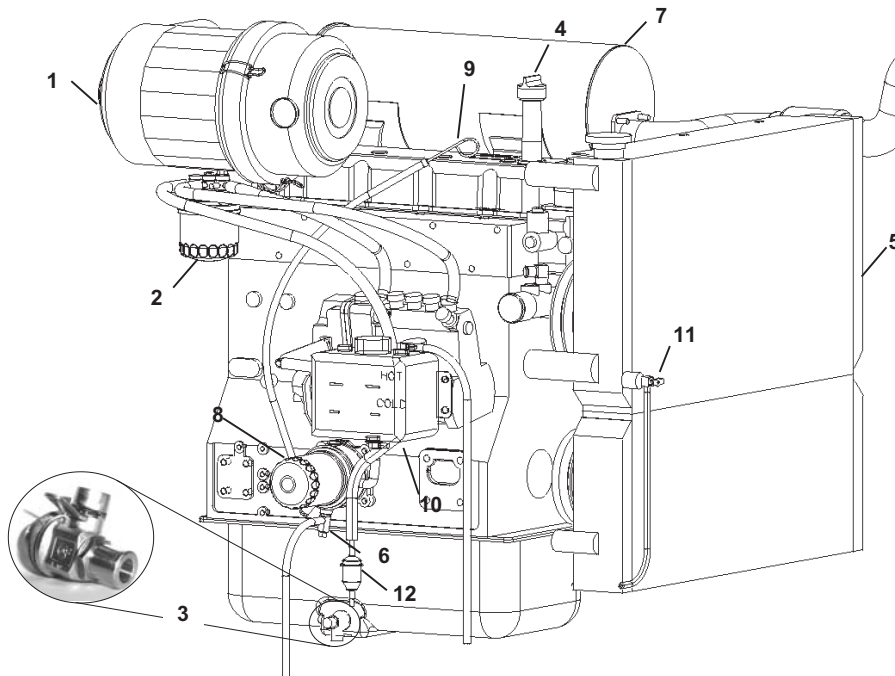

Fig. 41: Service Components

- | | |
|-------------------------------|----------------------------------|
| 1. Air Cleaner | 7. Muffler |
| 2. Fuel Filter | 8. Engine Oil Filter |
| 3. Engine Oil Drain Valve | 9. Engine Oil Dipstick |
| 4. Engine Oil Fill Plug | 10. Coolant Reservoir |
| 5. Radiator/Cooler | 11. Radiator Coolant Drain Valve |
| 6. Engine Coolant Drain Valve | 12. In-line Fuel Filter |

Check Oil Level

Open the rear door and engine cover (page 47). Pull out the dipstick and check the oil level. Markings on the dipstick represent FULL and LOW (add oil) levels.

Change Engine Oil and Filter

Important: *For new units, the initial oil change should be after the first 50 hours.*

1. Run the engine until it is at operating temperature. Stop the engine.
2. Place a pan under the hose behind the left rear tire and then open the valve on the oil pan to drain the oil.
3. Remove the oil filter. Clean the filter sealing surface.
4. Put clean oil on the new oil filter gasket. Install and tighten the filter a ½ turn past the point where the gasket contacts the filter head.
5. Close the oil drain valve.
6. Remove the oil cap and add the recommended oil. Refer to the “Lubrication” topic (page 49) for oil recommendations and capacities.
7. Start the engine and let it run for several minutes at low idle. Stop the engine. Check for leaks at the oil filter, drain valve and remote oil drain hose. Check the oil level. Add oil if it is not at the top mark on the dipstick.

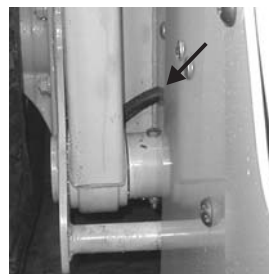

Fig. 42: Remote Oil Drain

Change Spin-On Fuel Filter

1. Remove the filter element.
2. Lubricate the element gasket with diesel fuel.
3. Install and tighten the filter element a ½ turn past the point where the gasket contacts the filter head.

The engine is self-priming, but if priming is needed, prime the filter assembly by loosening the bleed screw, and loosening and then stroking the lever until fuel runs out the bleed screw. Retighten the bleed screw and pump lever.

Change In-Line Fuel Filter

1. Loosen both clamps.
2. Replace the in-line filter.
3. Tighten clamps.

Hydraulic System

Refer to the *Maintenance Interval Chart* (page 71) for service intervals. Refer to the “Replacement Parts” topic (page 45) for replacement part numbers.

⚠ WARNING Before servicing the hydraulic system, be sure the lift arm is lowered.

Check Filter Indicators

Hydraulic oil filter: An indicator on the instrument panel lights when the filter becomes restricted.

Hydrostatic oil filter: A visual indicator on the filter turns red if the filter becomes restricted.

Check Oil Level

The loader has a sight gauge located on the left side of the skid loader. Check the fluid level with the lift arm lowered and the attachment on the ground.

Add hydraulic fluid as required. Refer to the “Lubrication” topic (page 49) for oil recommendations. Replace the cap.

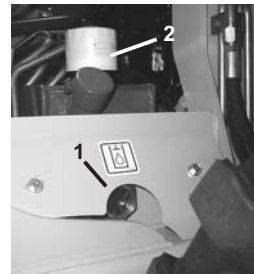

Fig. 43
1. Sight Gauge
2. Oil Refill Location

Change Oil Filters

The loader has both a hydraulic oil filter and a hydrostatic oil filter.

1. Remove the right access panel (page 47). Unscrew the filters.
2. Clean the surface of the filter housings where the element seal contacts the housing. Put clean oil on the rubber gasket of the new filter element.
3. Install and tighten the filter element a ½ turn past the point where the gasket contacts the filter head.

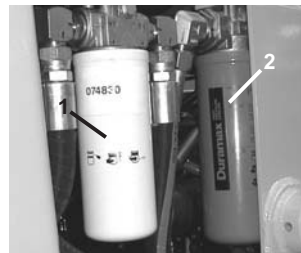

Fig. 44: Oil Filters
1. Hydrostatic Oil Filter
2. Hydraulic Oil Filter

Change Oil

The hydraulic oil must be replaced if it becomes contaminated, after major repairs and after 1000 hours or one year of use.

1. Unbolt the rear belly plate.
2. Install a catch pan of sufficient capacity under the oil reservoir (15 gallons; 56,8 liters).

3. Remove the drain plug located on the bottom left of the oil reservoir.
Early Units:*To drain the oil in earlier units, remove the belly plate and disconnect the lowest fitting from the front of the hydraulic tank.*
4. Change the oil filters.
5. Reinstall the drain plug (or fitting).
6. Refill the reservoir. Refer to the “Lubrication” topic (page 49) for oil recommendations.
7. Start the engine and operate the hydraulic controls.
8. Stop the engine and check for leaks at the filters and reservoir drain plug.
9. Check the fluid level and add fluid if needed.
10. Reinstall the rear belly plate.

Bucket Cutting Edge

The bucket cutting edge should be replaced when it is worn to within 1" (25 mm) of the bucket body.

Alternator/Fan Belt

Refer to the separate engine manual for setting proper belt tension. If the belt is worn, cracked or otherwise deteriorated, replace the belt following the procedure in the engine manual.

Wheel Nuts

Wheel nut torque must be checked before initial operation and every two hours thereafter until the wheel mounting hardware torque setting stabilizes at the recommended setting 180 ft-lbs (244 N·m). When wheels are removed and replaced, this procedure must be repeated.

Lift Arm Pivots

The lift arm pivot points should be torqued to 240 ft-lbs (325 N·m). Refer to the *Maintenance Interval Chart* (page 71) for the service interval for the lift arm pivots.

Cooling System

Important: *Check the cooling system every day to prevent overheating, loss of performance and engine damage.*

Refer to the *Maintenance Interval Chart* (page 71) for other service intervals.

Check Coolant Level

1. Remove the left access panel (page 47). Check that the coolant recovery tank is 1/3 to 1/2 full with a cold engine and 2/3 to 3/4 full with a hot engine.
2. Allow the coolant to cool. Do not remove the cap when the coolant is hot. Serious burns may occur.
3. Add premixed coolant, 50% water and 50% ethylene glycol, to the recovery tank if the coolant level is low.

Clean Cooling System

1. Park the loader on a level surface, lower the lift arm and stop the engine. Allow the machine to cool.
2. Open the rear door and engine cover (page 47).
3. Clean the radiator and oil cooler by blowing compressed air through the fins.

Drain/Flush Cooling System

Note: *Coolant must be drained from the radiator and the engine.*

1. Open the rear door and engine cover. Remove the left access panel (page 47).
2. **Radiator** - Open the drain valve located on the left side of the radiator and drain the coolant into a suitable container.
Engine - Open the drain valve located underneath the engine oil filter. The coolant will drain through a hose located behind the left rear tire. Drain the coolant into a suitable container.
3. Close the drain valves.

Note: *Protect the cooling system by adding premixed 50% water and 50% ethylene glycol to the system. This mixture will protect the cooling system to -34°F (-36°C).*

4. Fill the radiator fully and the recovery tank half full with the premixed coolant.
5. Reinstall the radiator cap.
6. Run the engine until it is at operating temperature. Stop the engine and let it cool. Check the coolant level. Add more fluid if required.

Tires

Rear tires usually wear faster than the front ones. To keep tire wear even, rotate the tires from front to rear and rear to front.

It is important to keep the same size tire on each side of the loader to prevent excessive wear on tires, chain and chaincase, or other damage. If different sizes are used, each tire will be turning at different speeds, causing excessive wear.

The tread bar of all tires must face the same direction.

Mounting Tires



WARNING Inflating or servicing tires can be dangerous. When possible, trained personnel should service and mount tires. To avoid possible death or serious injury, follow the safety precautions below:

Check Tire Pressure

Tire Size	Inflation Pressure	
	PSI	kPa
14 x 17.5 12-ply Heavy Duty Flotation	50	345

Correct tire pressure should be maintained for all tires to enhance operating stability and extend tire life. Refer to the above chart for the proper inflation pressure.

Heater Filters

Loaders with the optional heater or heater/air conditioner include two filters: fresh air intake and recirculation air. Refer to the “Replacement Parts” topic (page 45) for replacement part numbers. Filters should be replaced as needed.

Fresh Air Intake Filter: Located on the right side of the main unit. Tilt the ROPS back for access (page 47) and slide the filter out.

Recirculation Air Filter: Located on the front of the ROPS rear deck panel. Remove four screws and pull the filter out.

Electrical System

Circuit Breakers

The circuit breakers for the loader are located on the right instrument panel.

Battery

⚠ WARNING Before servicing the battery or electrical system, be sure the battery disconnect switch is in the OFF position.

The battery on the loader is a 12 volt, wet-cell battery, located under the operator's seat. To access the battery, remove the two cover plates (refer to Figs. 45, 46). Remote battery terminals and the battery disconnect switch are located at the rear of the loader.

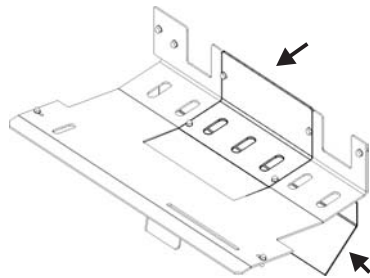

Fig. 45: T-bar and Dual Hand Battery Cover Plates

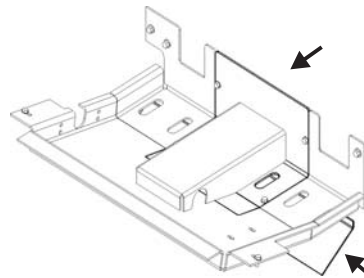

Fig. 46: Hand/Foot Battery Cover Plates

The battery top must be kept clean. Clean it with an alkaline solution (ammonia or baking soda and water). After foaming has stopped, flush the battery top with clean water. If the terminals and cable connection clamps are corroded or have a build-up, disconnect the cables and clean the terminals and clamps with the same alkaline solution.

**WARNING**

Explosive gas is produced while a battery is in use or being charged. Keep flames or sparks away from the battery area. **ALWAYS** charge the battery in a well-ventilated area.

Never lay a metal object on top of a battery, because a short circuit can result.

Battery acid is harmful on contact with skin or fabrics. If acid spills, follow these first-aid tips:

1. Immediately remove any clothing on which acid spills.
2. If acid contacts the skin, rinse the affected area with running water for 10 to 15 minutes.
3. If acid contacts the eyes, flood the eyes with running water for 10 to 15 minutes. See a doctor at once. Never use any medication or eye drops unless prescribed by the doctor.
4. To neutralize acid spilled on the floor, use one of the following mixtures:
 - a. 1 pound (0,5 kilogram) of baking soda in 1 gallon (4 liters) of water
 - b. 1 pint (0,5 liters) of household ammonia in 1 gallon (4 liters) of water

Whenever the battery is removed, be sure to disconnect the negative (-) battery terminal connection first.

TROUBLESHOOTING

Electrical System

Problem	Possible Cause	Remedy
Entire electrical system does not function.	Battery disconnect switch is OFF. 20 ampere breakers are tripped. Main wiring harness connectors at rear of ROPS not properly plugged in. Battery terminals or cables are loose or corroded. Battery is faulty.	Turn battery disconnect switch to ON. Check circuit and locate trouble before resetting breaker. Check main harness connectors. Clean battery terminals and cables and retighten them. Test battery and replace as needed.
No instrument panel lamps with keyswitch turned to "ON."	20 ampere breaker tripped. Battery terminals or cables are loose or corroded.	Check circuit and locate trouble before resetting breaker. Clean battery terminals and cables and retighten them.
Fuel gauge does not work.	Faulty fuel gauge sender. Faulty fuel gauge. Loose wiring/terminal connections.	Replace fuel gauge sender. Replace fuel gauge. Verify wiring connections.
Engine temperature gauge does not work.	Faulty temperature sender. Faulty temperature gauge. Loose wiring/terminal connections.	Replace temperature sender. Replace temperature gauge. Verify wiring connections.
Hourmeter does not work.	Loose wiring/terminal connections. Faulty alternator. Faulty hour meter.	Verify wiring connections. Repair the alternator. Replace hour meter.
Starter will not engage when key is turned to START.	Seat or restraint bar switch malfunctioning or not activated. Poor connections to starter relay in instrument panel. Battery terminals or cables loose or corroded. Faulty starter relay in instrument panel. Battery discharged or defective. Starter solenoid not functioning. Ignition wiring, seat switch, restraint bar switch, etc. loose or disconnected. Starter or pinion faulty.	Contact your dealer. Verify relay connections. Clean terminals, cables and retighten. Contact your dealer. Recharge or replace battery. Contact your dealer. Check wiring for poor connections, broken leads; repair wiring or connection. Remove starter; repair/replace as needed.

Electrical System

Problem	Possible Cause	Remedy
Work lights not functioning properly.	Single light doesn't work: Light bulb burned out, faulty wiring.	Check and replace light bulb as needed. Check wiring connection to light.
	No lights at all; 20 ampere breaker tripped.	Check circuit and locate trouble before replacing fuse.
	Faulty light switch or poor ground.	Replace light switch. Check ground wire connections.
Lift/Tilt and/or drive lock solenoids do not work.	Wiring to solenoids disconnected or faulty.	Troubleshoot circuit, repair.
	Restraint bar or seat switch malfunction.	Contact your dealer.
	Faulty solenoid valve coil.	Contact your dealer.
	Faulty hydraulic solenoid relay in instrument panel.	Contact your dealer.

Engine

Problem	Possible Cause	Remedy
Engine turns over but will not start.	Engine cranking speed too slow.	Battery requires recharging or replacing, or, in cold temperatures, pre-warm the engine.
	Auxiliary valve engaged.	Return the control valves to neutral.
	Fuel tank empty.	Refill fuel tank.
	Glow plug module malfunctioning.	Check connection and voltage, replace as needed.
	Fuel shut-off solenoid not energizing.	Check electrical connections and voltage to shut-off solenoid.
	Engine oil not warm enough.	Install a block heater.
	Ambient temperature is too low.	Install a block heater.
	Fuel filter(s) plugged. Fuel pump not working.	Replace the filter(s) Contact your dealer.
Engine overheats.	Crankcase oil level too low or too high.	Add or remove oil as required.
	Fan air circulation blocked or restricted.	With engine OFF, remove blockage or restriction.
	Fan shroud improperly positioned.	Contact your dealer.
	Grade of oil improper or excessively dirty.	Drain and replace with proper grade new oil.
	Exhaust restricted.	Allow exhaust to cool, remove restriction.
	Air filter is restricted.	Replace the filter(s).
	Low coolant level.	Add coolant.
Fan belt loose.	Tighten fan belt.	

Hydrostatic System

Problem	Possible Cause	Remedy
Hydrostatic (drive) system is noisy.	Hydraulic oil viscosity is too heavy. Air in hydraulic system. Drive motor(s) or hydrostatic pump(s) have internal damage or leakage.	Allow longer warm-up or replace existing oil with the proper viscosity oil. Cycle lift and tilt cylinders to maximum stroke and maintain pressure for a short time to clear air from system. Also check for low oil level in reservoir, fill as needed. Contact your dealer.
Left side doesn't drive in either direction. Right side operates normally.	Rear hydrostatic pump arm control lever loose. Relief valves on rear hydrostatic pump malfunctioning. Control rod linkage to rear hydrostatic pump disconnected.	Tighten. Contact your dealer. Attach control rod linkage.
Left side doesn't drive in forward direction.	Relief valve on rear hydrostatic pump is malfunctioning. Rear hydrostatic pump malfunctioning.	Contact your dealer. Contact your dealer.
Right side doesn't drive in either direction. Left side operates normally.	Front hydrostatic pump arm control lever loose. Relief valves on front hydrostatic pump malfunctioning. Control rod linkage to front hydrostatic pump disconnected.	Tighten. Contact your dealer. Attach control rod linkage.
Right side doesn't drive in one direction.	Relief valve on front hydrostatic pump is malfunctioning. Front hydrostatic pump malfunctioning.	Contact your dealer. Contact your dealer.

Hydraulic System

Problem	Possible Cause	Remedy
Auxiliary hydraulics do not function.	Restraint bar is raised.	Lower the restraint bar.
	Spool lock solenoid malfunctioning	Check electrical connections to lock solenoid and repair connections as needed. If still not functioning properly, contact your dealer.
	Restraint bar or seat switch malfunctioning.	Contact your dealer.
	Load sense signal line loose or broken.	Check line; tighten or replace if necessary.
	Load sense compensator not functioning.	Contact your dealer.
High flow auxiliary functions slowly.	High pressure compensator on pump not functioning.	Contact your dealer.
	Control linkage misadjusted.	Check linkage, readjust for full spool travel.
	Low engine speed.	Operate engine at higher speed.
	Hydraulic oil level low.	Add oil.
High flow auxiliary does not function	Hydraulic oil viscosity is too heavy.	Allow longer warming.
	Restraint bar is raised.	Lower the restraint bar.
	Spool lock solenoid malfunctioning.	Check electrical connections to lock solenoid and repair connections as needed. If still not functioning properly, contact your dealer.
	Restraint bar or seat switch malfunction.	Contact your dealer.
	Load sense signal line loose or broken.	Check line; tighten or replace if necessary.
High flow auxiliary does not function	Load sense compensation not functioning.	Contact your dealer.
	High pressure compensation on pump not functioning.	Contact your dealer.

MAINTENANCE SCHEDULE

This Maintenance Interval Chart was developed to match the *Service* chapter of this manual. Detailed information on each service procedure may be found in the *Service* chapter. A Maintenance Log follows the chart for recording the maintenance performed. Recording the 10 hour (or daily) service intervals would be impractical and is therefore not recommended.

Important: *Under severe operating conditions more frequent service than the recommended intervals may be required. You must decide, based on your use, if your operation requires more frequent service.*

Maintenance Interval Chart

Service Procedure	Maximum Interval		
	10 Hours (or Daily)	250 Hours	500 Hours (or Yearly)
Foreign Material Removal (p48)	●		
Check Engine Air Cleaner Restriction Indicator (p53)	●		
Check Engine Oil Level (p56)	●		
Check Hydraulic Oil Level (p57)	●		
Check Tire Pressures (p60)	●		
Grease Lift Arm, Hitch, Cylinder Pivots and Latch Pins (p49)	●		
Check Bucket Cutting Edge (p58)	●		
Test Safety Interlock System (p16)	●		
Check Coolant Level (p59)	●		
Clean Cooling System (p59)	●		
Check Drive Chain Tension (p52)		●	
Check Wheel Nuts Torque (p58)	○	●	
Check Lift Arm Torque (p58)		●	
Check Oil Level in Chaincases (p51)		●	
Check Alternator/Fan Belt Tensions (p58)		●	
Change Engine Oil and Filter (p56)	□	❖	●
Change Hydrostatic Oil Filter (p57)	□		●
Change Hydraulic Oil Filter (p57)			●
Check Battery (p61)			●
Check Engine Mounting Hardware (p55)			●
Change Fuel Filters (p56)			●
Change Hydraulic Oil (p57)			◆
Change Chaincase Oil (p51)	□		◆
Drain/Flush Cooling System (p59)			●

- Perform the initial procedure at 2 hours then at “●” intervals.
- Perform the initial procedure at 50 hours then at “●” or “◆” intervals.
- ❖ Severe operating conditions.
- ◆ Perform the procedure at 1000 hours.

SPECIFICATIONS

Loader Specifications

Operating Weight	
7600	9745 lb (4420 kg)
7800	9955 lb (4515 kg)
Shipping Weight	
7600	8040 lb (3650 kg)
7800	8175 lb (3710 kg)
SAE Rated Operating Load ¹	
7600	3150 lb (1429 kg)
7800	3600 lb (1633 kg)
Engine	
Make	Yanmar
Model	
7600	4TNE106
7800	4TNE106T
Displacement	269 in ³ (4.4 L)
Power (net) @ 2500 rpm	
4TNE106	90 hp (67 kW)
4TNE106T	110 hp (82 kW)
Peak Torque @ 1600 rpm	
4TNE106	240 lb-ft (325 N·m)
4TNE106T	301 lb-ft (408 N·m)
Hydraulic System (theoretical)	
Main Hydraulic System Pressure	3300 psi (228 bar)
Standard Flow Rating	40 gpm (151 L/min)
Electrical	
Battery	12 Volt DC with 950 CCA min.
Starter	12 Volt DC (3 kW)
Alternator	60 amperes
Capacities	
Chaincase (each)	3 U.S. gal (11,4 L)
Engine Oil	14.8 U.S. qts (14 L)
Fuel Tank	29.5 U.S. gal (112 L)
Hydraulic Reservoir	15 U.S. gal (56,8 L)
Sound Levels (with Deluxe Sound Kit)	
Pressure Level (Operator Ear)	92 dB(A)
Power Level (Environmental)	106 dB(A)

¹ Operating load rated with an 82" (2083 mm) (7600 - 21 ft³; 7800 - 27 ft³) dirt/construction bucket in accordance with SAE J818.

Standard Features

- Fuel Gauge
- Engine Coolant Temperature Gauge and Light
- Hourmeter
- Oil Pressure, Battery Charge Indicator
- Seatbelt Indicator Light and Buzzer
- Choice of three control types: T-Bar, Hand & Foot or Dual Hand
- Foot Throttle (T-Bar and Dual Hand only)
- Acoustical Material, Floor Mat and Headliner
- Adjustable Operator Restraint Bar with Armrests
- Hydraulic Lift ROPS
- Fixed-Top Window and Opening Rear Window
- Full Suspension Adjustable Seat (7800 only)
- ROPS-FOPS ISO Level II
- Number 100HK Drive Chain
- Skid Plate for Clean Out
- Hydraulic Oil Filter Indicator Light
- Horn
- Interior Dome Light
- Hydraloc™ System – Brakes and Interlock for Starter, Lift Cylinders, Tilt Cylinders, Wheel Drives, Auxiliary and High Flow Hydraulics
- Dual Element Air Cleaner with Visual Indicator
- Anti-Vandalism Tailgate/Step for Service Access
- Glow Plug Starting Assist
- Servo-Controlled Hydrostatic Drive
- Lift Arm Support Device
- Self-Leveling Lift Action
- Independent Steel Hydraulic Reservoir
- Dual Front & Rear Halogen Work Lights and Dual Tail Lights
- Bi-directional Adjustable Flow Auxiliary Hydraulics with Flush-Faced Couplers
- Powerview® Vertical Path Lift Arm
- Choice of All-Tach™ Attachment Mounting System: Single Lever (Manual) or Power
- Bi-directional High Flow Auxiliary Hydraulics with Flush-Faced Couplers (7800 only)
- Remote Battery Jump Terminals
- Battery Disconnect Switch
- Engine Auto-Shutdown System

Accessories

- 3-inch Wide Seatbelt – When Required by Law
- Sliding Side Windows
- Deluxe Sound Package
- Rear View Mirror
- Suspension Seat (option on 7600)
- Impact-Resistant Front Door
- Front Door with Wiper
- Operator's Compartment Heater/Defroster/Air Conditioner
- Audible Back-Up Alarm
- Strobe Light
- Dual Flasher Kit
- Bucket Bolt-On Cutting Edge Kits
- Four-Point Lift Kit
- Single-Point Lift Kit
- Hydraulic Couplers Kit
- Centrifugal Pre-Cleaner
- Engine Block Heater
- 2-Speed Transmission (option on 7600)
- Diesel Engine Exhaust Purifier
- Hydraglide™ Ride Control System

Dimensional Specifications

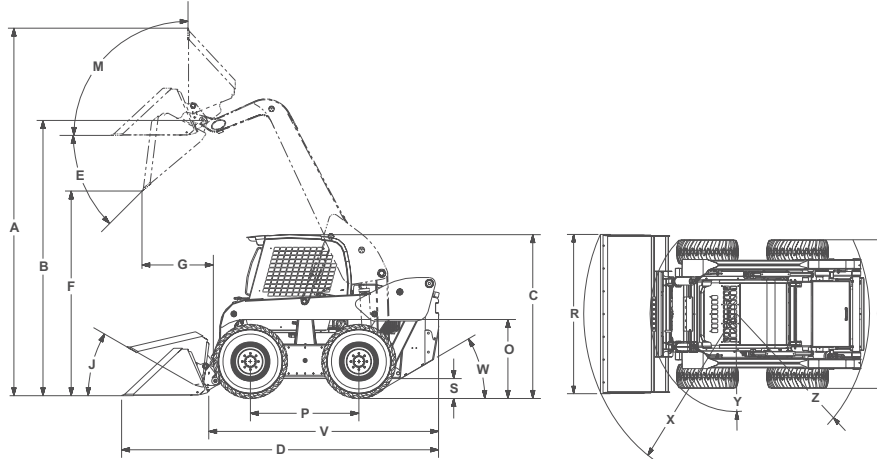

	3/4 Yd ³ Bucket w/14 X 17.5 Tires		1 Yd ³ Bucket w/14 X 17.5 Tires	
	inches	(mm)	inches	(mm)
A Overall Operation Height - Fully Raised	185.8	(4719)	189.3	(4808)
B Height to Hinge Pin - Fully Raised	142.0	(3607)	142.0	(3607)
C Overall Height - Top of ROPS	81.1	(2060)	81.1	(2060)
D Ground Clearance - to Chassis (Between Wheels)	9.1	(231)	9.1	(231)
E Overall Length - Bucket Down	155.8	(3957)	159.3	(4046)
F Overall Length (Less Bucket)	117.5	(2985)	117.5	(2985)
G Wheel Base - Nominal	54.3	(1379)	54.3	(1379)
H Dump Reach - Bucket Full Height	33.0	(838)	36	(914)
I Rollback at Ground	28°		28°	
J Dump Angle at Full Height	40°		40°	
K Overall Width - Less Bucket	80.3	(2040)	80.3	(2040)
L Bucket Width - Overall	84.0	(2134)	84.0	(2134)
M Clearance Circle - Rear	72.0	(1829)	72.0	(1829)
N Clearance Circle - Front (Less Bucket)	58.3	(1481)	58.3	(1481)
O Clearance Circle - Front (With Bucket)	98.1	(2492)	101.3	(2573)
P Seat to Ground Height	40.5	(1029)	40.5	(1029)
Q Rollback Angle at Full Height	97°		97°	
R Dump Height	108.0	(2743)	105.7	(2685)
S Departure Angle	30°		30°	
Reach Maximum (Bucket Flat)	48.5	(1232)	52.0	(1321)
Maximum Back Grading Angle	86°		86°	

Capacities and Ratings

Note: Use the Table of Common Materials and Densities (page 79) for selecting the appropriate bucket.

Dirt / Construction Buckets

Description ¹	Weight	7600 Rating	7800 Rating
82/84" 21 ft ³ (2083/2121 mm 0.6 m ³)	660 lb (300 kg)	3150 lb (1430 kg)	3700 lb (1678 kg)
82/84" 27 ft ³ (2083/2121 mm 0.8 m ³)	700 lb (318 kg)	3050 lb (1383 kg)	3600 (1633 kg)

Pallet Forks @ 24" (1610 mm) Load Center

Description	Weight	7600 Rating	7800 Rating
48" (1219 mm) Forks with Backrest	450 lb (204 kg)	2270 lb (1030 kg)	2680 lb (1216 kg)

¹ inner/outer dimensions give

Table of Common Materials and Densities

Material	Density	
	(lb/ft ³)	(kg/m ³)
Ashes	35-50	560-800
Brick-common	112	1792
Cement	110	1760
Charcoal	23	368
Clay, Wet-Dry	80-100	1280-1600
Coal	53-63	848-1008
Concrete	115	1840
Cinders	50	800
Coal-anthracite	94	1504
Coke	30	480
Earth-dry loam	70-90	1121-1442
Earth-wet loam	80-100	1281-1602
Granite	93-111	1488-1776
Gravel-dry	100	1602
Gravel-wet	120	1922
Gypsum-crushed	115	1840
Iron Ore	145	2320
Lime	60	960
Lime Stone	90	1440
Manure-liquid	65	1040
Manure-solid	45	720
Peat-solid	47	752
Phosphate-granular	90	1440
Potash	68	1088
Quartz-granular	110	1760
Salt-dry	100	1602
Salt-Rock-solid	135	2160
Sand-dry	108	1728
Sand-wet	125	2000
Sand-foundry	95	1520
Shale-crushed	90	1440
Slag-crushed	70	1120
Snow	15-50	240-800
Taconite	107	1712

Note: The densities listed are average values and intended only as a guide for bucket selection. For a material that is not in the table, obtain its density value before selecting the appropriate bucket.

To use the table, find the material name and see what its maximum density is. Then, multiply the loader rating of the attachment by the material density to determine if the attachment can safely be used. See page 78 for a listing of attachments and their loader ratings.

Note: *Where the material density is listed as a range (clay at 80-100 lb/ft³, for example), always use the maximum density (100 lb/ft³ in this example) for making calculations. Also, see the following examples.*

Example 1: If clay (density of 80-100 lb/ft³) is to be hauled using an SL7800 model loader using a 27 ft³ Dirt/Construction Bucket, the bucket capacity is 27 ft³ and the loader rating is 3600 lb. Multiply the density of clay (100 lb/ft³) by the capacity of the bucket (27 ft³) to achieve the weight being carried (100 lb/ft³ x 27 ft³ = 2700 lb). This number is less than the machine rating so you could safely use this bucket in this application.

Example 2: If granite (density of 1488-1776 kg/m³) is to be hauled using an SL7600 model loader using a 21 ft³ Dirt/Construction Bucket, the bucket capacity is 0.6 m³ and the loader rating is 1430 kg. Multiply the density of granite (1776 kg/m³) by the capacity of the bucket (0.6 m³) to achieve the weight being carried (1776 kg/m³ x 0.6 m³ = 1066 kg). This number is less than the machine rating so you could safely use this bucket in this application.

INDEX

A		D	
Accessory Plug	19	Cooling System	59
Adjustments	48	Check Coolant Level	59
Control Handles	48	Clean	59
Engine Speed Control	48	Drain/Flush	59
Fuel Sender	48		
Air Conditioner			
See Heater			
Alternator/Fan Belt	58		
Attachments	21,37		
Capacities and Ratings	78		
Auxiliary Hydraulic Controls			
High Flow	32		
Standard Flow	31		
B		E	
Battery	61	Emergency Exit	17
Disconnect Switch	16	Engine Air Cleaner	53
Jump-starting	36	Engine Compartment Access	47
Bucket Cutting Edge	58	Engine Mounting Hardware	55
Bucket, Usage	39	Engine Service	
Digging with a Bucket	39	Change Fuel Filters	56
Driving on an Incline	39	Change Oil and Filter	56
Driving over Rough Terrain	39	Check Oil Level	56
Dumping Into a Box	40		
Dumping Onto a Pile	40		
Dumping Over an Embankment	40		
Leveling the Ground	41		
Loading a Bucket	40		
Scraping with a Bucket	41		
C		F	
Chaincases	51	Foreign Material Removal	48
Checking and Adding Oil	51		
Draining Oil	51		
Circuit Breakers	61		
Cold Starting Procedure	35		
Control/Indicator Symbols	4		
CONTROLS AND SAFETY EQUIPMENT	15		
		G	
		Guards and Shields	15
		H	
		Hand/Foot Controls	27
		Auxiliary Hydraulic Controls	31
		Drive Controls	27
		Lift/Tilt Controls	28
		Heater	
		Filter Service	60
		Operation	19
		Heater and Air Conditioner	
		See Heater	
		Highway Travel	42

TORQUE SPECIFICATIONS

Use these torque values when tightening hardware (excluding: locknuts, and self-tapping, thread forming, and sheet metal screws) unless otherwise specified.

UNIFIED NATIONAL THREAD	GRADE 2		GRADE 5		GRADE 8	
	DRY	LUBED	DRY	LUBED	DRY	LUBED
8-32	19*	14*	30*	22*	41*	31*
8-36	20*	15*	31*	23*	43*	32*
10-24	27*	21*	43*	32*	60*	45*
10-32	31*	23*	49*	36*	68*	51*
1/4-20	66*	50*	9	75*	12	9
1/4-28	76*	56*	10	86*	14	10
5/16-18	11	9	17	13	25	18
5/16-24	12	9	19	14	25	20
3/8-16	20	15	30	23	45	35
3/8-24	23	17	35	25	50	35
7/16-14	32	24	50	35	70	55
7/16-20	36	27	55	40	80	60
1/2-13	50	35	75	55	110	80
1/2-20	55	40	90	65	120	90
9/16-12	70	55	110	80	150	110
9/16-18	80	60	120	90	170	130
5/8-11	100	75	150	110	220	170
5/8-18	110	85	180	130	240	180
3/4-10	175	130	260	200	380	280
3/4-16	200	150	300	220	420	320
7/8-9	170	125	430	320	600	460
7/8-14	180	140	470	360	660	500
1-8	250	190	640	480	900	680
1-12	270	210	710	530	1000	740

METRIC COARSE THREAD	GRADE 8.8		GRADE 10.9		GRADE 12.9	
	DRY	LUBED	DRY	LUBED	DRY	LUBED
M6-1	8	6	11	8	13.5	10
M8-1.25	19	14	27	20	32.5	24
M10-1.5	37.5	28	53	39	64	47
M12-1.75	65	48	91.5	67.5	111.5	82
M14-2	103.5	76.5	145.5	108	176.5	131
M16-2	158.5	117.5	223.5	165.5	271	200

*All Torque Values are in ft-lbs except those marked with an * which are in in-lbs.

For metric torque value (N·m) multiply ft-lbs value by 1.355 or the in-lbs value by 0.113.

GEHL CONSTRUCTION

WARRANTY

GEHL CONSTRUCTION DIVISION of the GEHL COMPANY, hereinafter referred to as Gehl, warrants new Gehl construction equipment to the Original Retail Purchaser to be free from defects in material and workmanship for a period of twelve (12) months from the Warranty Start Date, except as set forth below.

GEHL CONSTRUCTION WARRANTY SERVICE INCLUDES:

Genuine Gehl parts and labor costs required to repair or replace equipment at the selling dealer's business location.

GEHL MAKES NO REPRESENTATIONS OR WARRANTIES OF ANY KIND, EXPRESS OR IMPLIED (INCLUDING THE IMPLIED WARRANTIES OF MERCHANTABILITY AND FITNESS FOR PARTICULAR PURPOSE), EXCEPT AS EXPRESSLY STATED IN THIS WARRANTY STATEMENT.

GEHL WARRANTY SERVICE DOES NOT INCLUDE:

1. Transportation to selling dealer's business location or, at the option of the Original Retail Purchaser, the cost of a service call.
2. Used equipment.
3. Components covered by their own non-Gehl warranties, such as tires, trade accessories and engines.
4. Normal maintenance service and expendable, wear-out items.
5. Repairs or adjustments caused by: improper use; failure to follow recommended maintenance procedures; use of unauthorized parts or attachments; accident or other casualty.
6. Liability for incidental or consequential damages of any type, including, but not limited to lost profits or expenses of acquiring replacement equipment.

No agent, employee or representative of Gehl has any authority to bind Gehl to any warranty except as specifically set forth herein. Any of these limitations excluded by local law shall be deemed deleted from this warranty; all other terms will continue to apply.

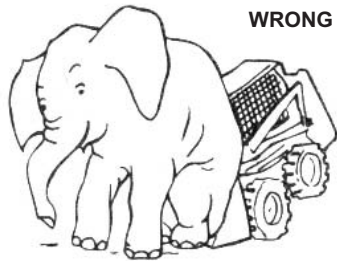

⚠ Never exceed rated operating load.

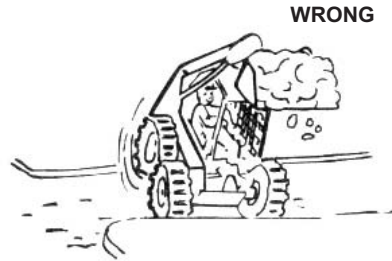

⚠ Always carry attachments as low as possible. Do not travel or turn with the lift arms raised. Load, unload and turn on flat level



⚠ Never carry riders.

⚠ Keep bystanders away from work area.



⚠ Never modify equipment.

⚠ Use only attachments approved for this model loader.

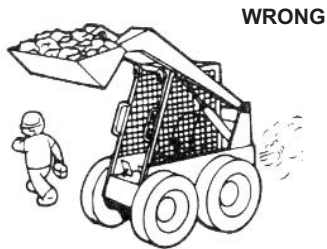

⚠ Never leave loader with engine running or with lift arm up. To park, engage parking brake and put attachment flat on the ground.



**THIS OPERATOR'S MANUAL IS
PROVIDED FOR OPERATOR USE**

DO NOT REMOVE FROM THIS MACHINE

Do not start, operate or work on this machine until you carefully read and thoroughly understand the contents of this Operator's Manual.

Failure to follow safety, operating and maintenance instructions can result in serious injury to the operator or bystanders, poor operation, and costly breakdowns.

If you have any questions on proper operation, adjustment or maintenance of this machine, contact your dealer or the Gehl Company Service Department before starting or continuing operation.

California Proposition 65 Warnings

Diesel engine exhaust and some of its constituents are known to the State of California to cause cancer and birth defects or other reproductive harm.

Battery posts, terminals and related accessories contain lead and lead compounds, chemicals known to the State of California to cause cancer and birth defects or other reproductive harm. Wash hands after handling battery.

GEHL®

Gehl Company 143 Water Street, P.O. Box 179, West Bend, WI 53095-0179 U.S.A.
www.gehl.com