

Four Sided Pyramid Hanging Structures

PSQ
 Four Sided Pyramid tension fabric hanging structures are made in the USA and are of the utmost quality and durability. State-of-the-art zipper pillowcase dye-sublimated stretch fabric coverings are combined with advanced, lightweight aluminum structures to provide unique design, functionality, and style. Hanging structures are offered in a wide variety of shapes and sizes. Stretch fabric graphics are hand-sewn, durable and dry-cleanable.

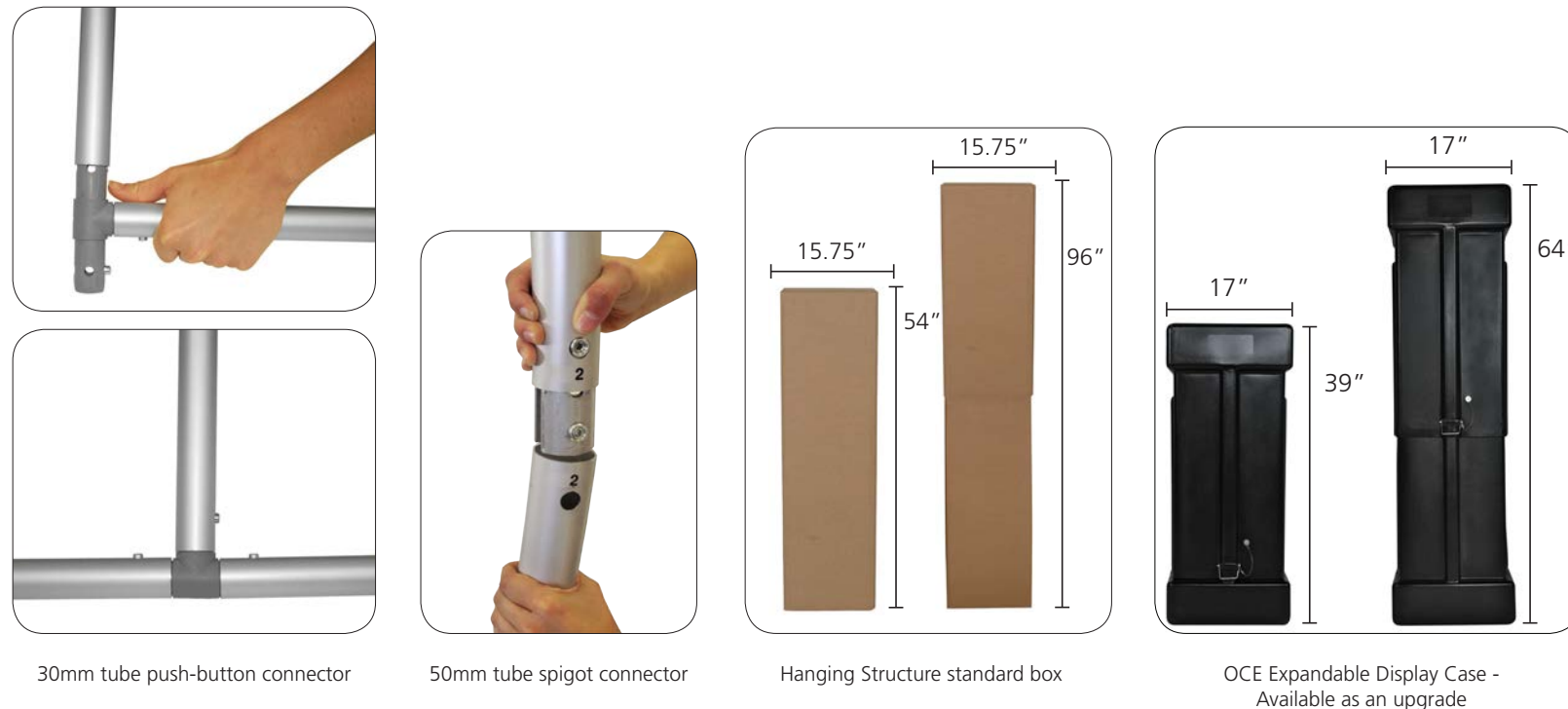
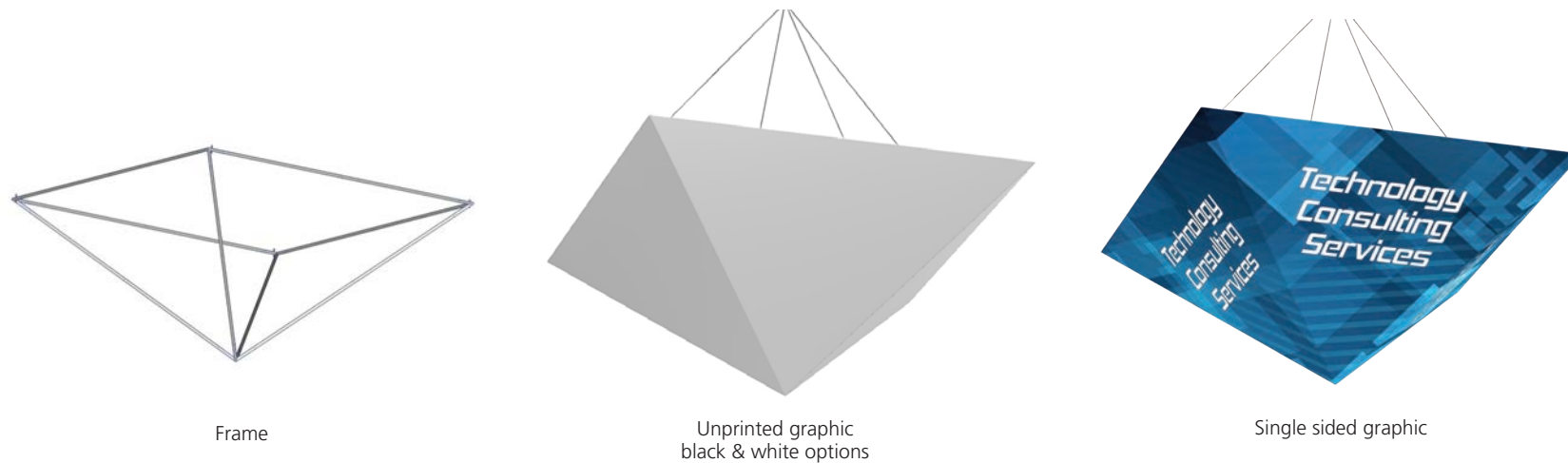

features and benefits:

- Four sided pyramid hanging structures come in 10', 12', 16', & 20' width configurations at varying heights of 5', 6', 8' & 10'
- Shapes 12' width and under are constructed with 30mm (1^{1/8}") tubes and push-button connectors for simple assembly
- Shapes 16' width and over are constructed with 50mm (2") tubes and internal expanding spigot connectors for unmatched structural integrity
- Engineer certified (structural engineer certificate available upon request)
- Zippered pillowcase fabric graphic options include: unprinted (white and black) and single-sided (outer panel printed only).
- All pillowcase graphics come standard with opaque liner
- Comes standard with hanging hardware, bags and heavy-duty shipping and storage box(es)
- OCE Expandable rugged molded shipping cases available as an upgrade
- Collapses to a fraction of its size
- Easy to store and ship
- Quick to set up

dimensions:

Hardware can be found on page 2

Graphic dimensions can be found in the graphic templates.

Graphic Material:
 5 oz. Soft Knit Dye-sublimated zipper pillowcase fabric

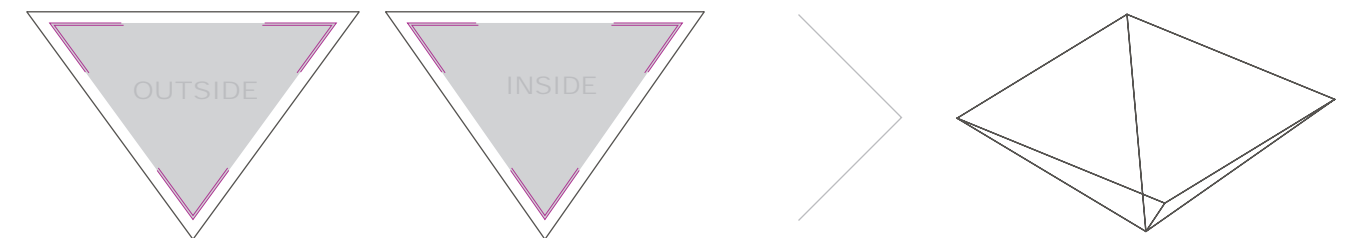

PSQ-10' WIDTH					
HEIGHT	HARDWARE CODE	# OF BOXES OR CASES	UNPRINTED GRAPHIC CODE	SINGLE-SIDED GRAPHIC CODE	OUTER GRAPHIC SPECS
5'	PSQ-1005	1	PSQ-1005-U	PSQ-1005-G	SEE GRAPHIC TEMPLATE
PSQ-12' WIDTH					
HEIGHT	HARDWARE CODE	# OF BOXES OR CASES	UNPRINTED GRAPHIC CODE	SINGLE-SIDED GRAPHIC CODE	OUTER GRAPHIC SPECS
6'	PSQ-1206	1	PSQ-1206-U	PSQ-1206-G	SEE GRAPHIC TEMPLATE
PSQ-16' WIDTH					
HEIGHT	HARDWARE CODE	# OF BOXES OR CASES	UNPRINTED GRAPHIC CODE	SINGLE-SIDED GRAPHIC CODE	OUTER GRAPHIC SPECS
8'	PSQ-1606	2	PSQ-1606-U	PSQ-1606-G	SEE GRAPHIC TEMPLATE
PSQ-20' WIDTH					
HEIGHT	HARDWARE CODE	# OF BOXES OR CASES	UNPRINTED GRAPHIC CODE	SINGLE-SIDED GRAPHIC CODE	OUTER GRAPHIC SPECS
10'	PSQ-2002	2	PSQ-2002-U	PSQ-2002-G	SEE GRAPHIC TEMPLATE

***ALL GRAPHIC SIZES NOTED ARE FINISHED SIZES AND DO NOT INCLUDE REQUIRED BLEEDS. REFERENCE GRAPHIC TEMPLATE.**

We are continually improving and modifying our product range and reserve the right to vary the specifications without prior notice. All dimensions and weights quoted are approximate and we accept no responsibility for variance. E&OE. See Graphic Templates for graphic bleed specifications.

PSQ-1005

- SET UP INSTRUCTIONS:**
1. CONNECT BOTTOM AND TOP TUBES FOLLOWING THE LABELS
 2. CONNECT SIDE TUBES
 3. CLEAN THE FRAME AND PLACE THEM ON CLEAN PLACE
 4. CAREFULLY REMOVE FABRIC COVER FROM BAG
 5. PLACE COVER AROUND THE BOTTOM OF THE FRAME
 6. PULL COVER CAREFULLY UP TO THE TOP
 7. CLOSE ALL ZIPPERS
 8. ADJUST FABRIC AROUND THE FRAME
 9. CONNECT CABLE HARNESS TO THE EYEBOLTS
 10. COMPLETELY TIGHTEN THREADED CONNECTORS

- BREAK DOWN INSTRUCTIONS:**
REVERSE SET-UP STEPS TO BREAKDOWN FRAME

- FABRIC CARE INSTRUCTIONS:**
1. UNZIP COVER ZIPPERS
 2. CAREFULLY REMOVE FABRIC COVER
 3. CLOSE ALL ZIPPERS
 4. FOLD OR ROLL NEATLY
 5. PLACE FABRIC IN COVER BAG

FRAME ASSEMBLY

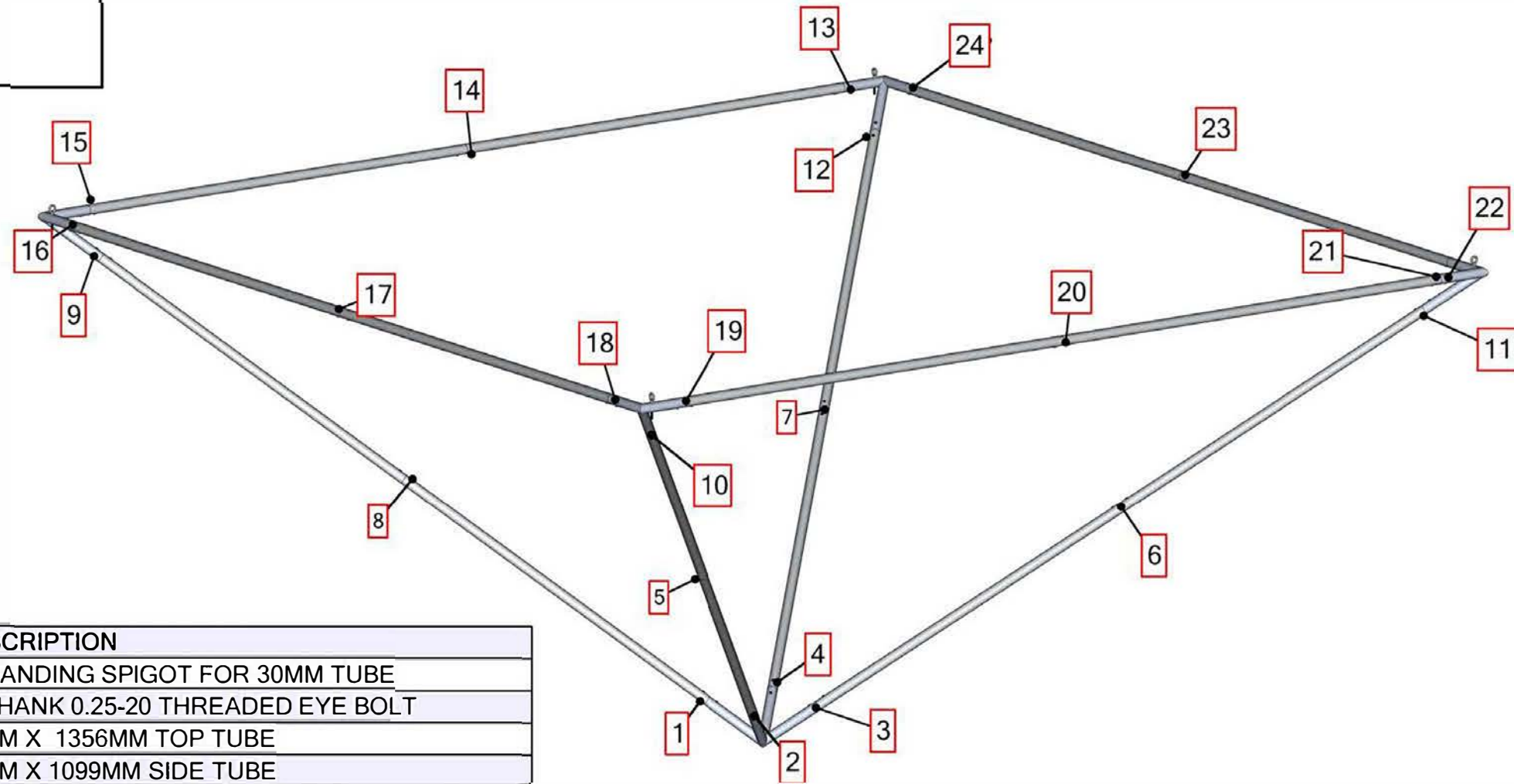

TOTAL WEIGHT: 62.37 (lbs)
HARDWARE: 22.37 (lbs)
GRAPHIC: 40.0 (lbs)

QTY	CODE	DESCRIPTION
24	ES-30	EXPANDING SPIGOT FOR 30MM TUBE
4	EYEBOLTS-0.25-20-2	2" SHANK 0.25-20 THREADED EYE BOLT
8	PSQ-10-T1	30MM X 1356MM TOP TUBE
8	PSQ-10-T2	30MM X 1099MM SIDE TUBE
4	PSQ-CORNER-30MM	30MM TOP CORNER SECTION 4-SIDED PYRAMID

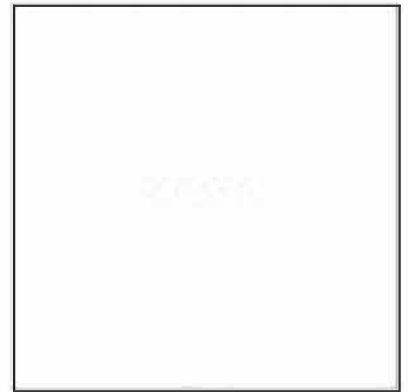
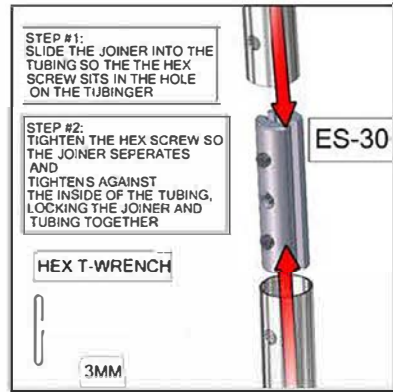
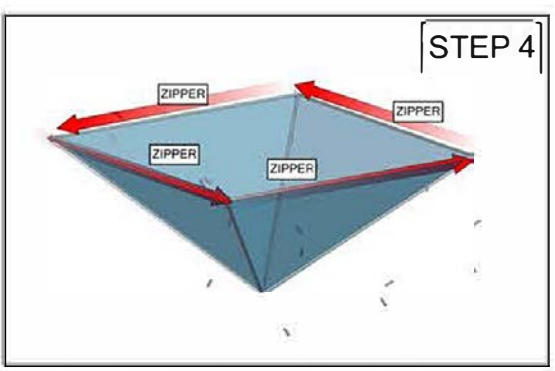
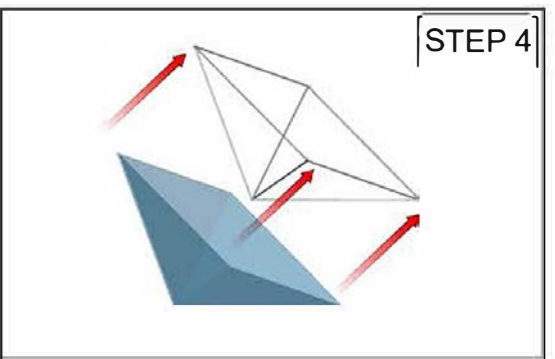
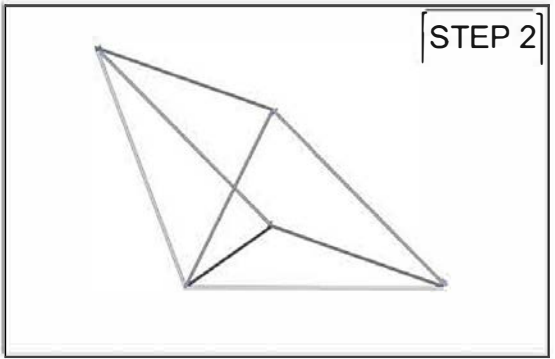
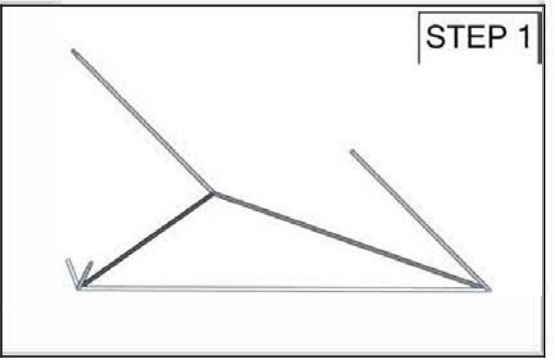

PSQ-1206

- SET UP INSTRUCTIONS:**
1. CONNECT BOTTOM AND TOP TUBES FOLLOWING THE LABELS
 2. CONNECT SIDE TUBES
 3. CLEAN THE FRAME AND PLACE THEM ON CLEAN PLACE
 4. CAREFULLY REMOVE FABRIC COVER FROM BAG
 5. PLACE COVER AROUND THE BOTTOM OF THE FRAME
 6. PULL COVER CAREFULLY UP TO THE TOP
 7. CLOSE ALL ZIPPERS
 8. ADJUST FABRIC AROUND THE FRAME
 9. CONNECT CABLE HARNESS TO THE EYEBOLTS
 10. COMPLETELY TIGHTEN THREADED CONNECTORS

- BREAK DOWN INSTRUCTIONS:**
REVERSE SET-UP STEPS TO BREAKDOWN FRAME

- FABRIC CARE INSTRUCTIONS:**
1. UNZIP COVER ZIPPERS
 2. CAREFULLY REMOVE FABRIC COVER
 3. CLOSE ALL ZIPPERS
 4. FOLD OR ROLL NEATLY
 5. PLACE FABRIC IN COVER BAG

FRAME ASSEMBLY

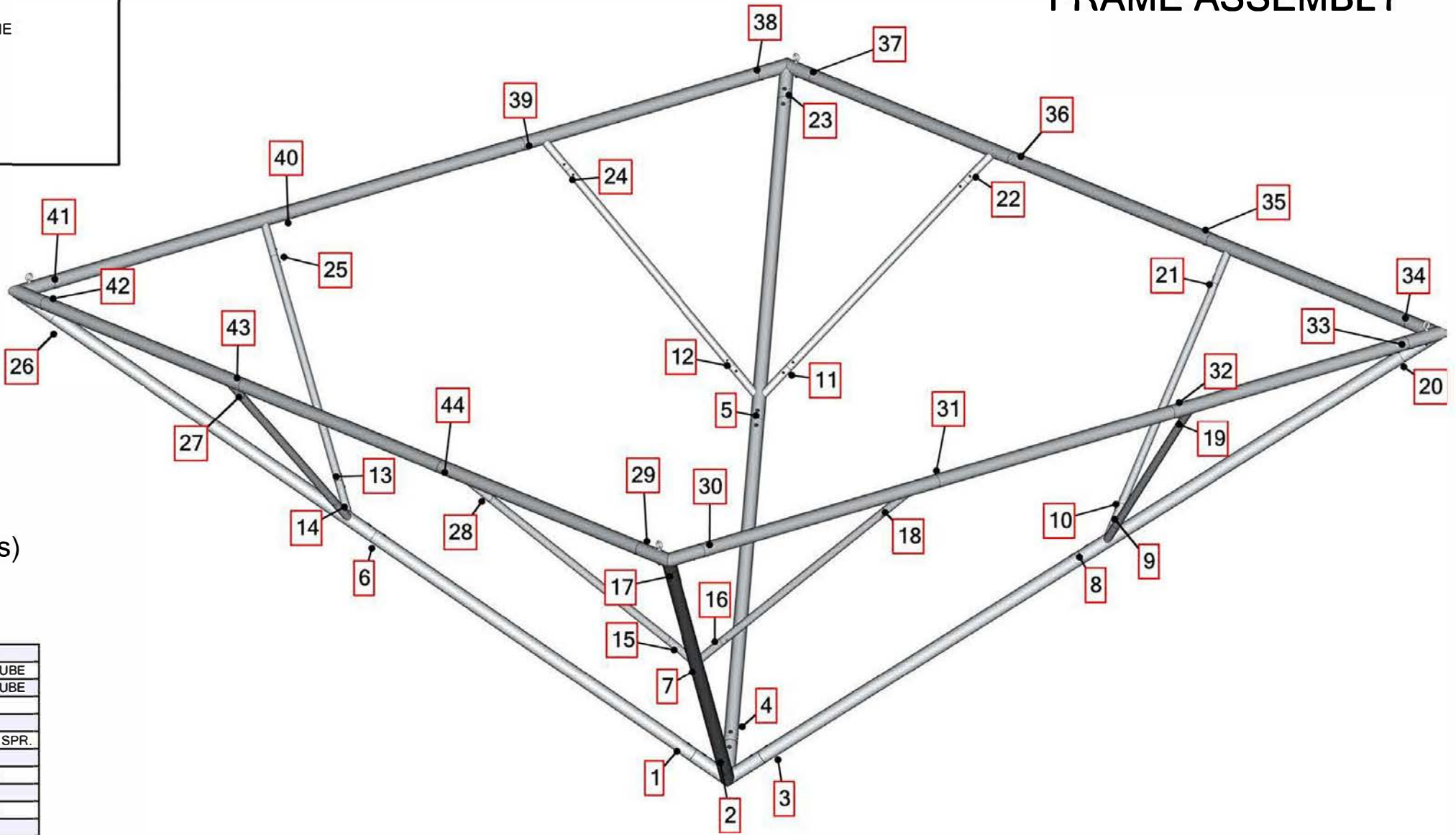

TOTAL WEIGHT: 162.9 (lbs)
HARDWARE: 89.0 (lbs)
GRAPHIC: 65.0 (lbs)

QTY	CODE	DESCRIPTION
16	ES-30	EXPANDING SPIGOT FOR 30MM TUBE
33	ES-50	EXPANDING SPIGOT FOR 50MM TUBE
4	PSQ-1206-T2	50MM 3-WAY TOP CORNER
4	EYEBOLT	5/16-18 x 2.5" STEEL EYEBOLT
4	PSQ-1206-T3	50MM CORNER TUBE WITH 30MM SPR.
4	PSQ-1206-T1	50MM 4-WAY CORNER
5	PSQ-1206-T5	50MM TOP TUBE WITH 30MM SPR
8	PSQ-1206-T7	30MM SPREADER TUBE
4	1206-T5-M	50MM TOP TUBE WITH 30MM SPR
4	PSQ-1206-T4	50MM CORNER TUBE
4	PSQ-1206-T6	50MM TOP TUBE

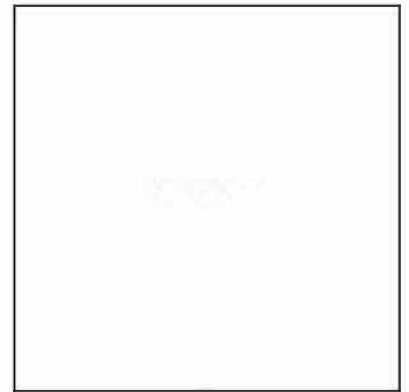
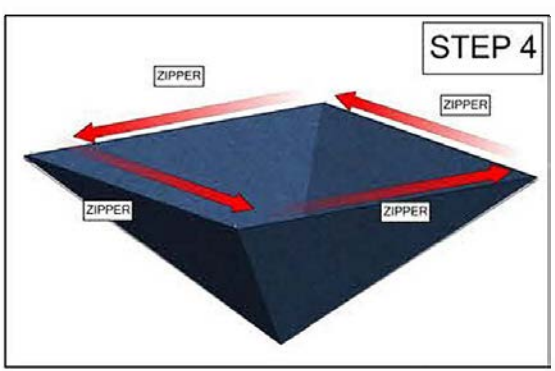
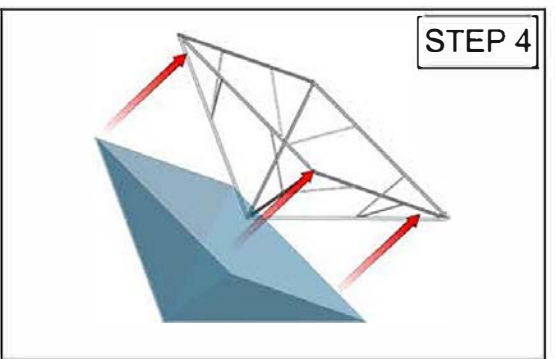
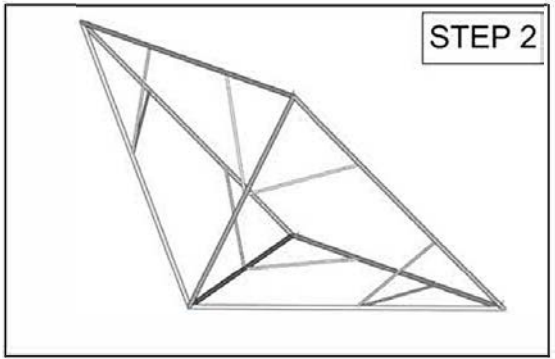
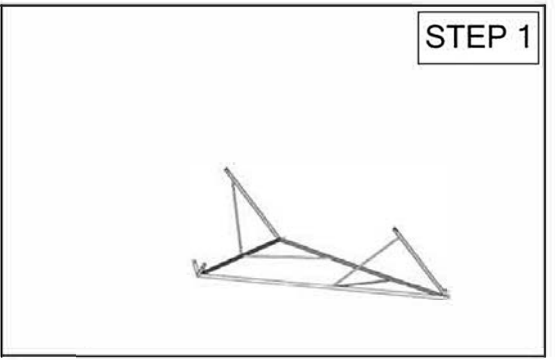
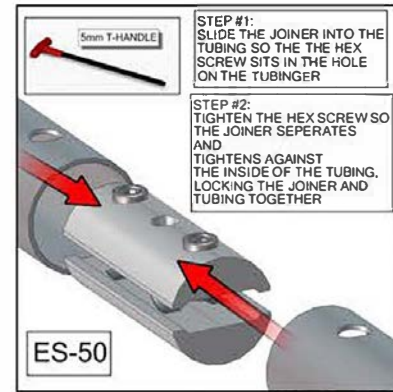
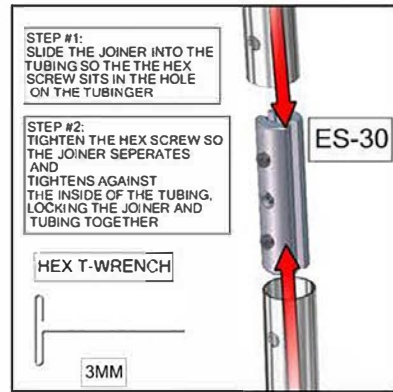

PSQ-1608

FRAME ASSEMBLY

- SET UP INSTRUCTIONS:**
1. CONNECT BOTTOM AND TOP TUBES FOLLOWING THE LABELS
 2. CONNECT SIDE TUBES
 3. CLEAN THE FRAME AND PLACE THEM ON CLEAN PLACE
 4. CAREFULLY REMOVE FABRIC COVER FROM BAG
 5. PLACE COVER AROUND THE BOTTOM OF THE FRAME
 6. PULL COVER CAREFULLY UP TO THE TOP
 7. CLOSE ALL ZIPPERS
 8. ADJUST FABRIC AROUND THE FRAME
 9. CONNECT CABLE HARNESS TO THE EYEBOLTS
 10. COMPLETELY TIGHTEN THREADED CONNECTORS

- BREAK DOWN INSTRUCTIONS:**
REVERSE SET-UP STEPS TO BREAKDOWN FRAME

- FABRIC CARE INSTRUCTIONS:**
1. UNZIP COVER ZIPPERS
 2. CAREFULLY REMOVE FABRIC COVER
 3. CLOSE ALL ZIPPERS
 4. FOLD OR ROLL NEATLY
 5. PLACE FABRIC IN COVER BAG

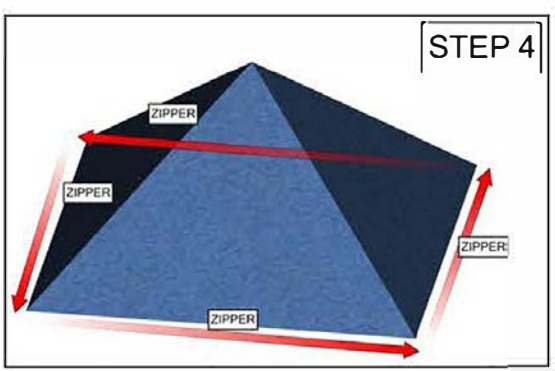
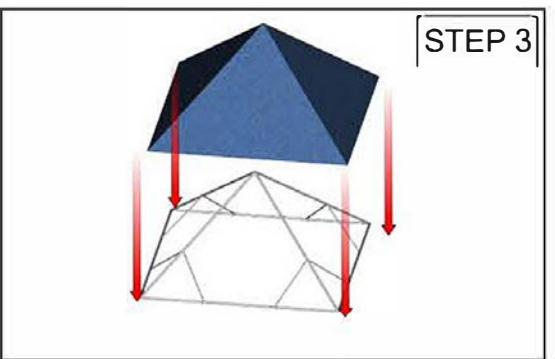
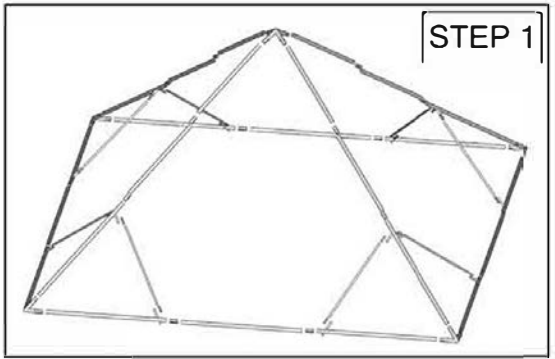
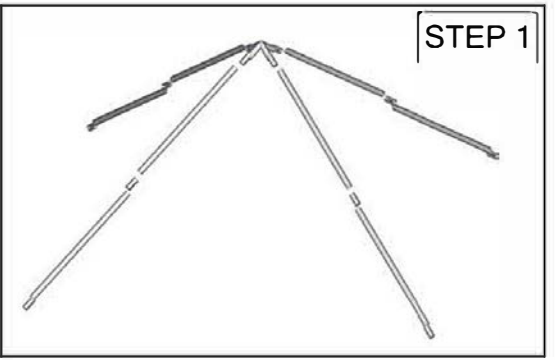
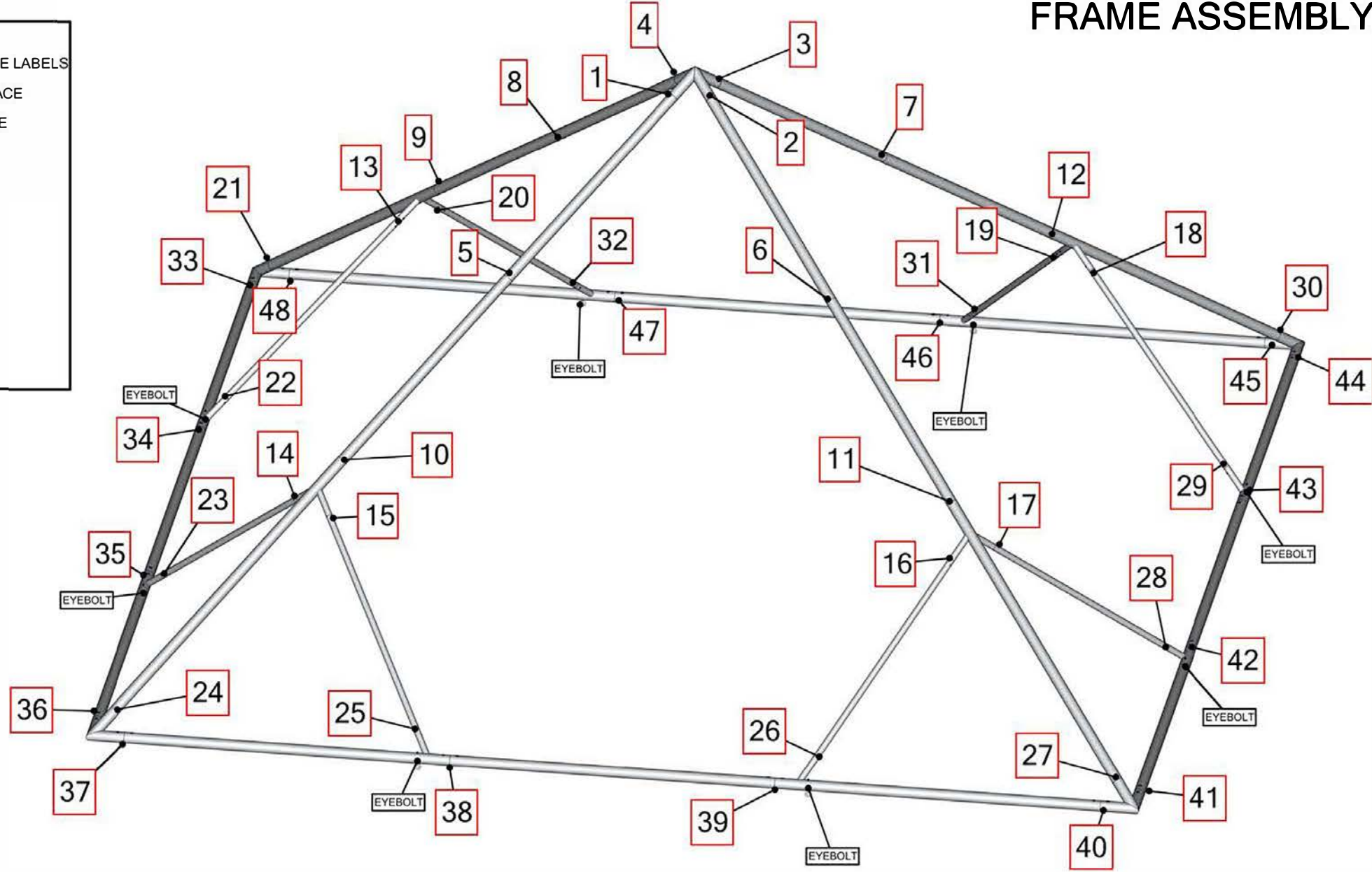

TOTAL WEIGHT: 181.71 (lbs)
HARDWARE: 101.71 (lbs)
GRAPHIC: 80 (lbs)

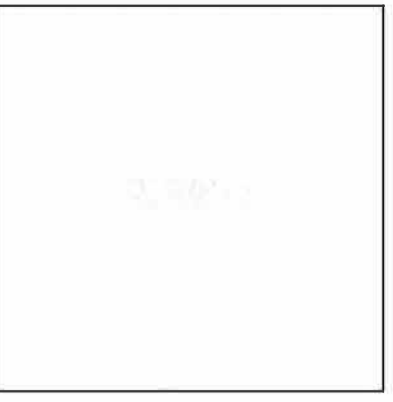
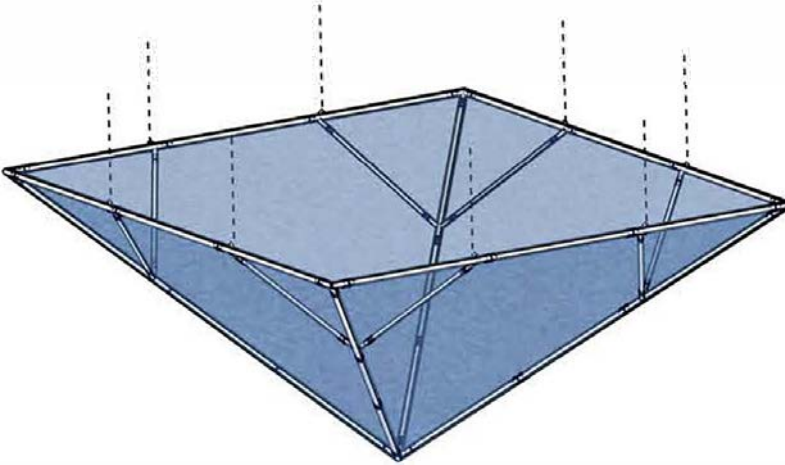
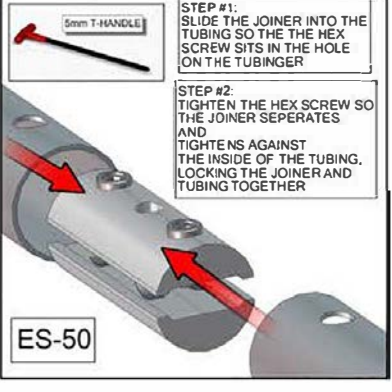
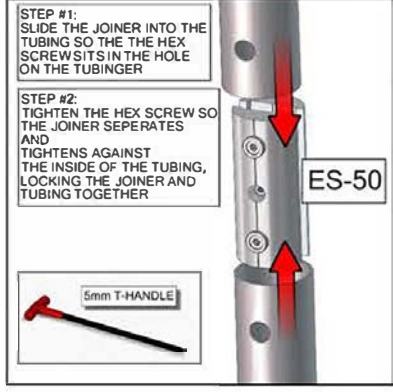
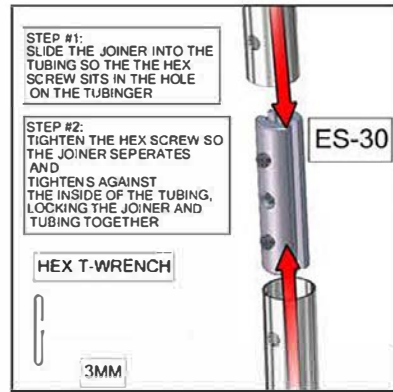

PSQ-2010

SET UP INSTRUCTIONS:

1. CONNECT BOTTOM AND TOP TUBES FOLLOWING THE LABELS
2. CONNECT SIDE TUBES
3. CLEAN THE FRAME AND PLACE THEM ON CLEAN PLACE
4. CAREFULLY REMOVE FABRIC COVER FROM BAG
5. PLACE COVER AROUND THE BOTTOM OF THE FRAME
6. PULL COVER CAREFULLY UP TO THE TOP
7. CLOSE ALL ZIPPERS
8. ADJUST FABRIC AROUND THE FRAME
9. CONNECT CABLE HARNESS TO THE EYEBOLTS
10. COMPLETELY TIGHTEN THREADED CONNECTORS

BREAK DOWN INSTRUCTIONS:
REVERSE SET-UP STEPS TO BREAKDOWN FRAME

FABRIC CARE INSTRUCTIONS:

1. UNZIP COVER ZIPPERS
2. CAREFULLY REMOVE FABRIC COVER
3. CLOSE ALL ZIPPERS
4. FOLD OR ROLL NEATLY
5. PLACE FABRIC IN COVER BAG

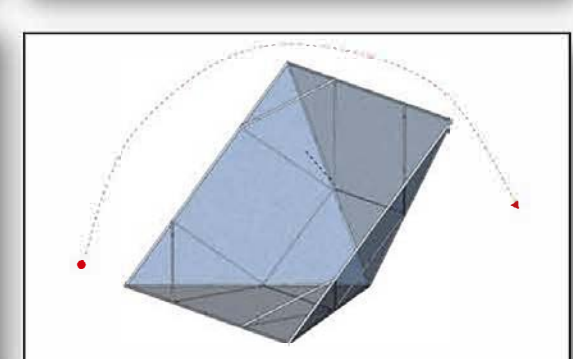
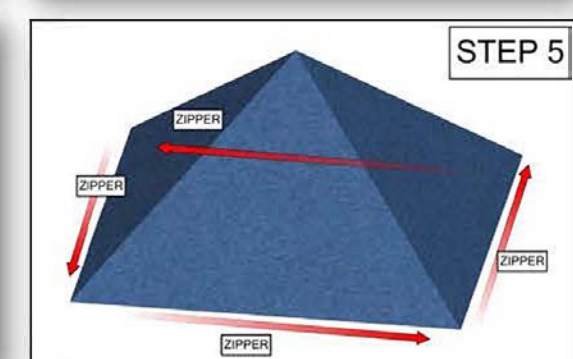
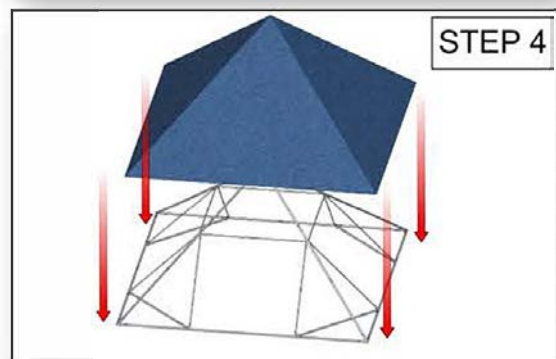
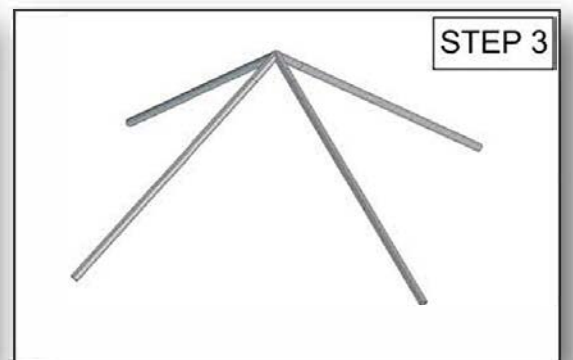
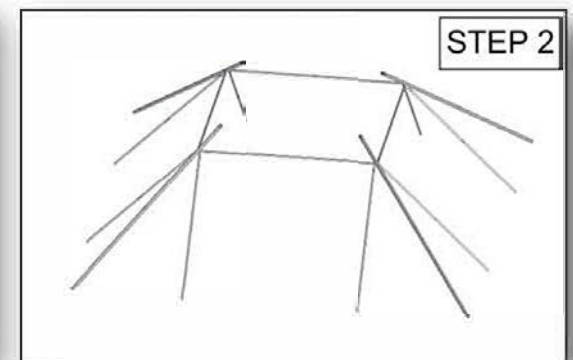
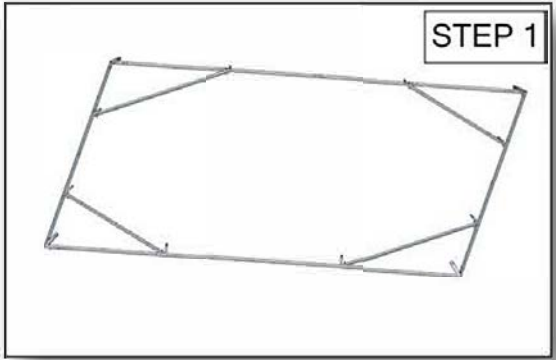
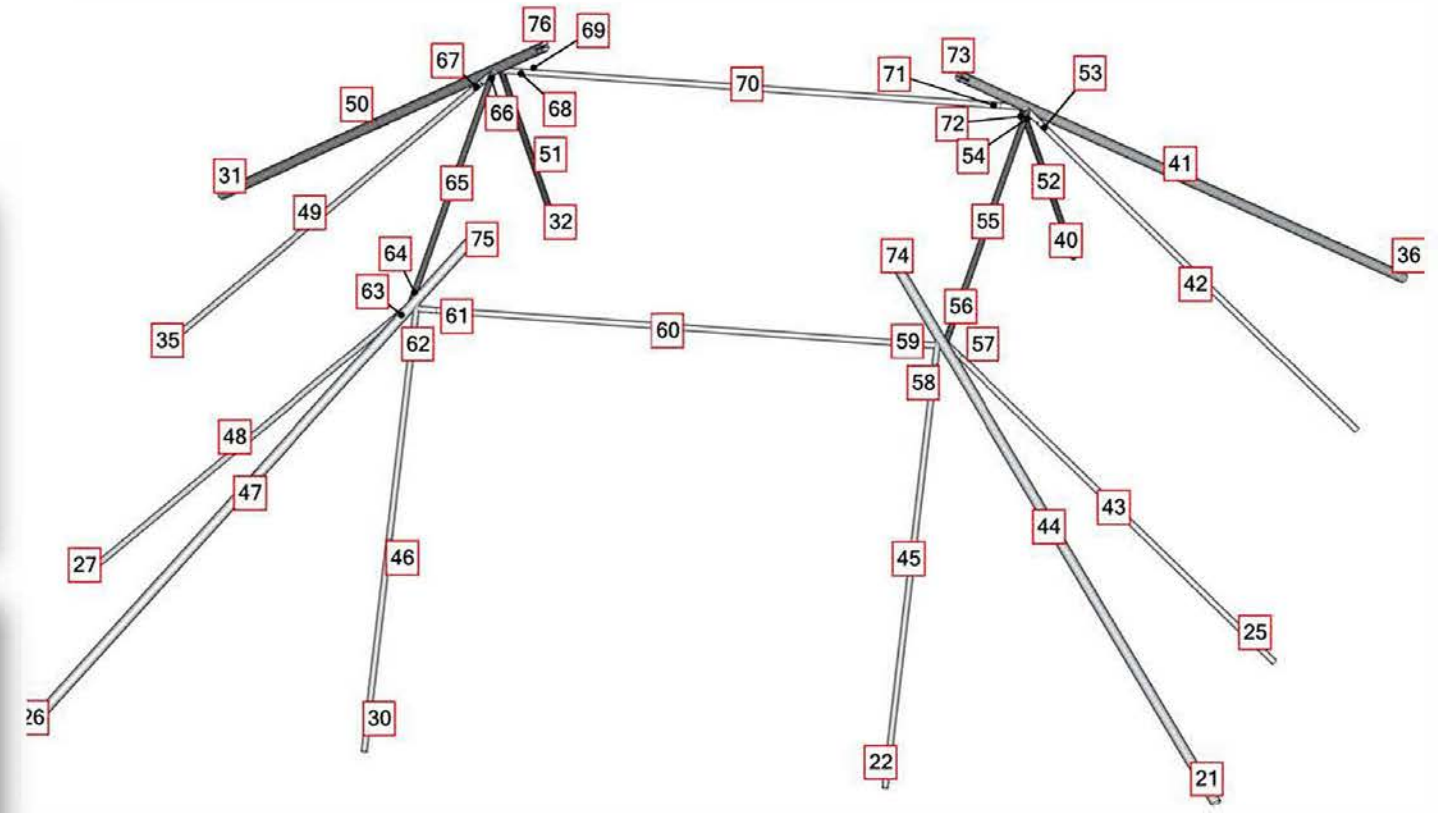
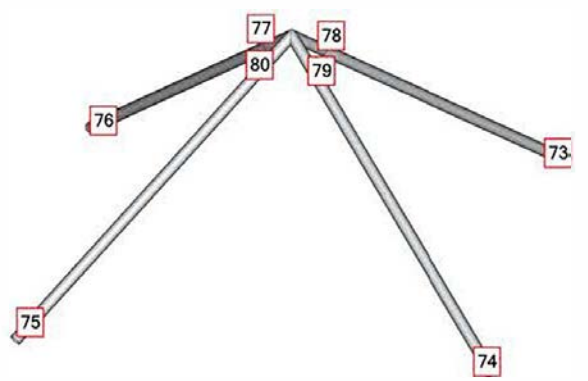
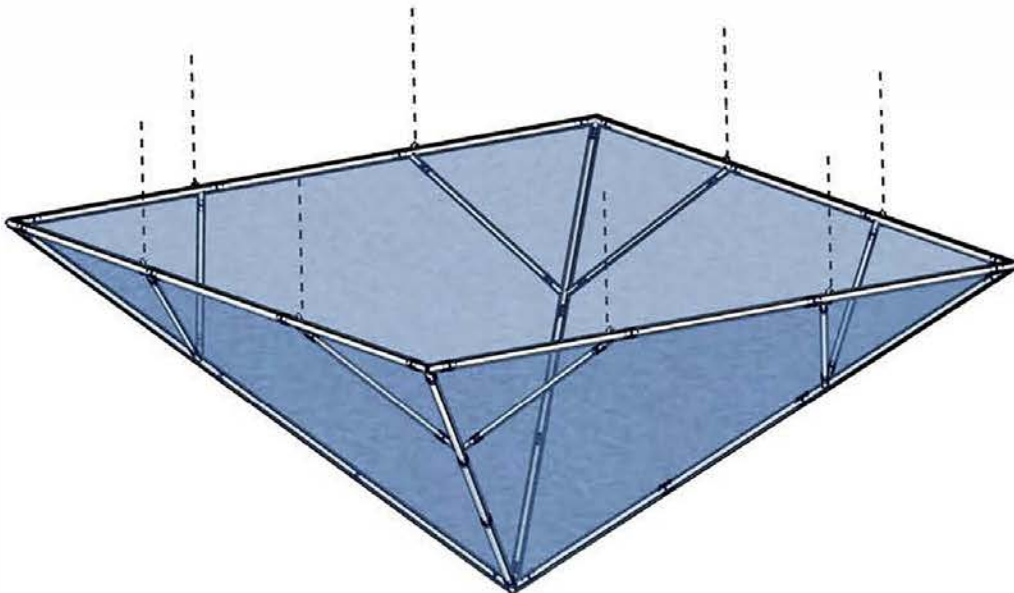

TOTAL WEIGHT: 343.0 (lbs)
HARDWARE: 180.0 (lbs)
GRAPHIC: 145.0 (lbs)

