

Presentation
Low speed performance of axial piston machines

Bath/ASME Symposium on Fluid Power and Motion Control FPMC2018

September 12-14, 2018

Peter Achten, INNAS, The Netherlands (www.innas.com)

Low speed performance of pumps and motors



I N N A S

Peter Achten

Bath/ASME Symposium on Fluid Power and Motion Control,
FPMC 2018, 12-14 September 2018, University of Bath

Thank you, mister chairman, and good morning to all of you.

Let me start by skipping the first two words of the title of my presentation. I will not only talk about low speed performance measurements, but about performance tests in general, also at high rotational speeds.

Modern science

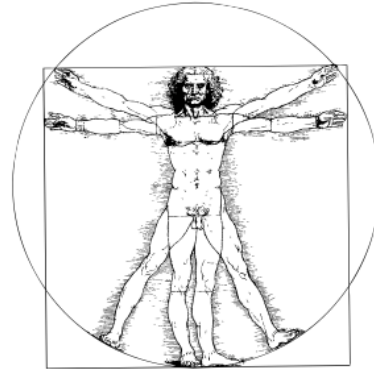

The willingness to admit ignorance

Observation and mathematics

Finding solutions

According to Yuval Harari, modern science is the single most important revolution in the history of mankind. According to Harari:

'The key to modern science is the willingness to admit ignorance. Modern science is based on the Latin injunction *ignoramus*, which means: 'we do not know'... at least not everything.

Now, having admitted ignorance, modern science aims to obtain new knowledge. It does so by gathering observations and then using mathematical tools to connect these observations into comprehensive theories.

But, modern science is not content with just creating theories. It uses these theories in order to acquire new powers, and in particular to develop new technologies and finding new solutions and products.'

In addition, it is my strong believe that modern science only works if we have an open and transparant discussion and debate.

Without doubt, Monika Ivantysynova was the queen of debate in our small fluid power community. Let this presentation be a tribute to Monika.

A new test bench for hydrostatic machines

Last year, at the previous Bath/ASME-symposium, I introduced our new test bench for hydrostatic machines.

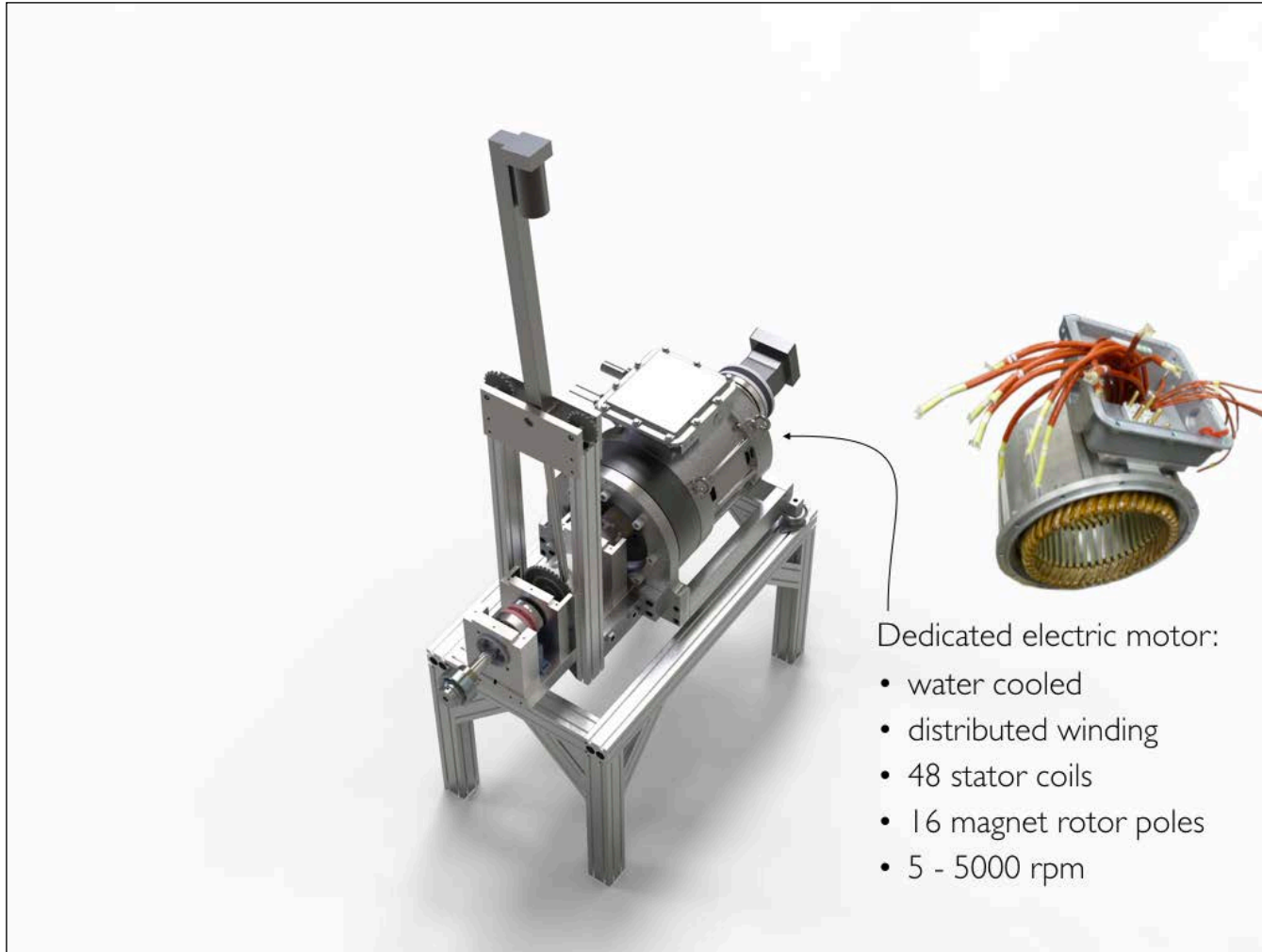

It is a special test bench in which a high speed test bench and low speed test bench are combined.

A dedicated electric motor has been produced

The motor is water-cooled, which allows it to be operated at relatively low speeds

It has a distributed winding with 48 stator coils and 16 rotor poles. The configuration has been chosen to create a very smooth torque. In the end, we want to measure the torque variations from the hydrostatic machine, and not from the electric motor.

Recently, we introduced a speed sensor in the control of this motor, and we can now operate the motor in a range between 5 and 5000 rpm without large speed variations.

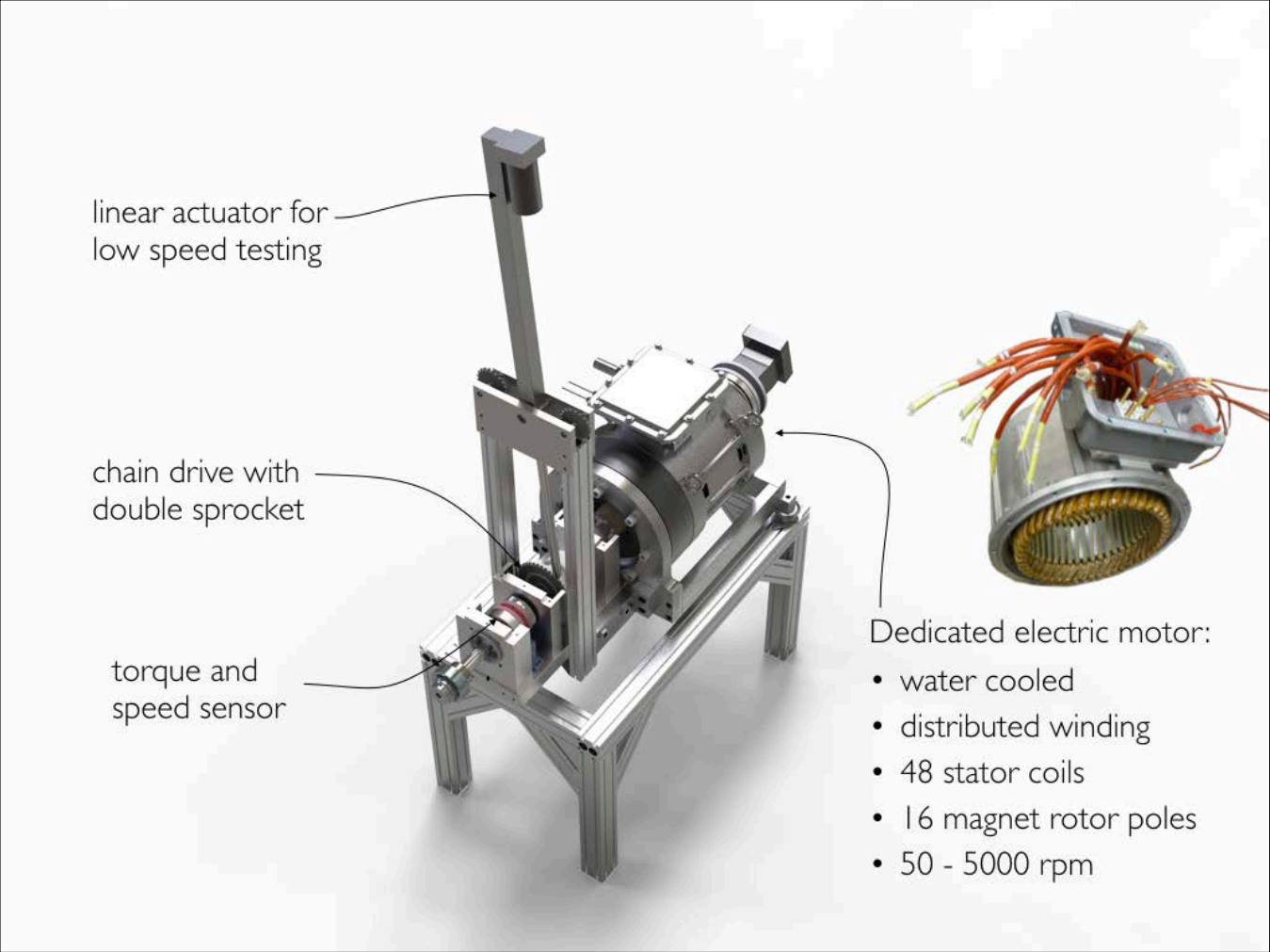

For testing at very low operating speeds, we have added a linear actuator and a chain drive.

The low speed test bench uses the same sensors as the high speed test bench.

Demands

- measurements from ≈ 0.001 rpm up to 5000 rpm
- reproducible and comparable
- motor and pump operation
- also after various periods of standstill

Aside from being able to test hydrostatic machines in an extremely wide range of rotational speeds, the demands were that the tests should be reproducible and comparable.

Both motors and pumps can be tested.

The test bench should also be capable of testing breakaway conditions, even after various periods of standstill.

A new test bench

- To make hydraulic pumps better
- To make hydraulic motors better
- To improve the control of hydraulic systems
- ...curiosity



We developed this new test bench to make better hydraulic pumps, motors and systems. And, to be honest, also because we were curious how pumps and motors would behave at these extremely low operating speeds.



Now it is quite understandable that we want test motors at low rotational speeds, because they often start at high loads.

Why low speed testing of pumps?

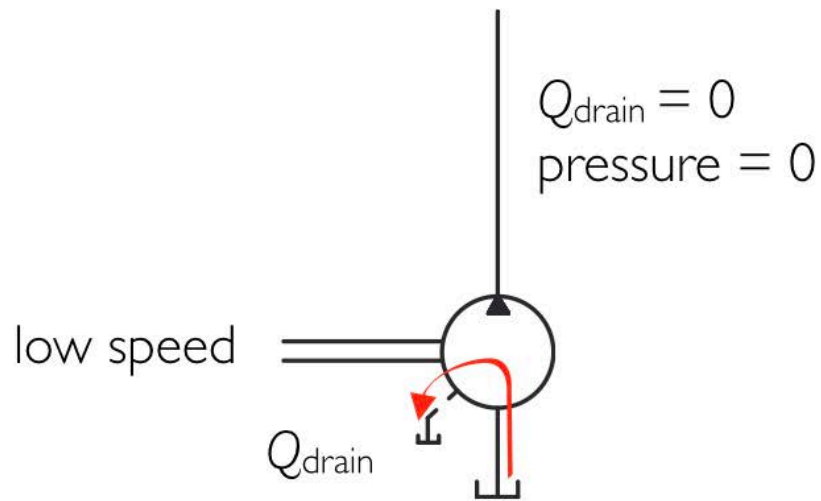

But why should we bother about testing pumps at these speeds?

After all, at low rotational speeds, the drain losses are often higher, than the flow, that the pump can create. In that case, the pump can't build up any pressure, at least not on itself.

However, the answer to this question is rather simple. In the real world, the pump is never operated at itself,...

Why low speed testing of pumps?

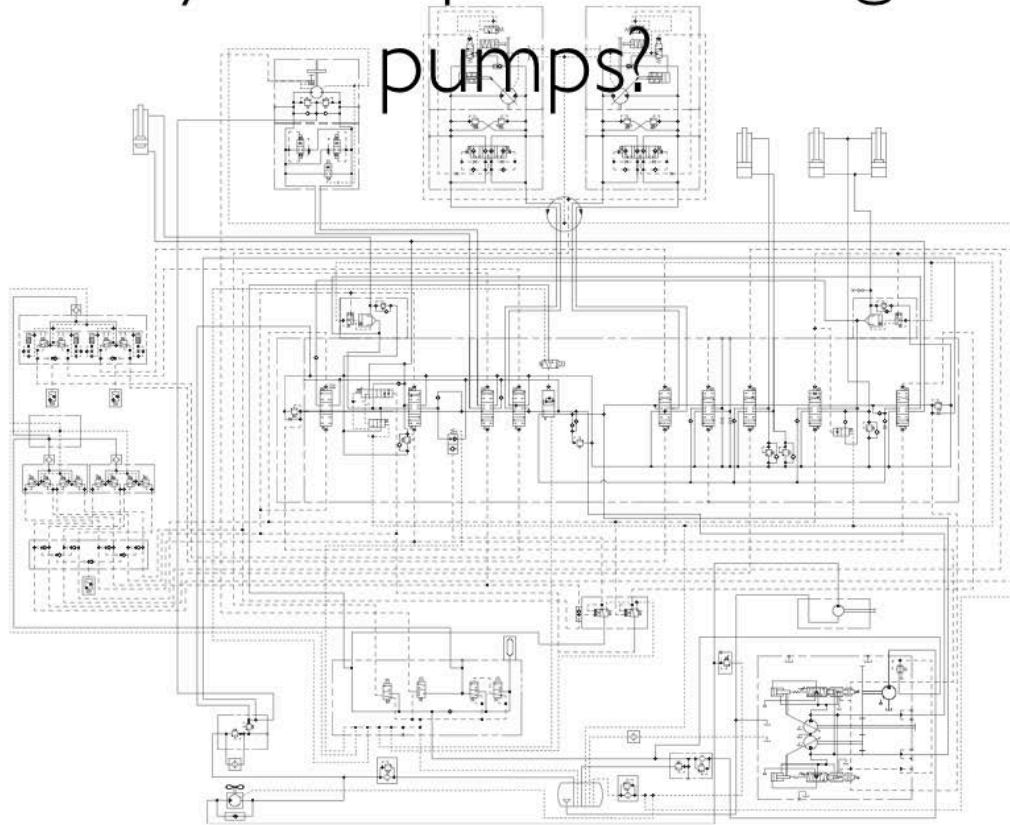

...but is always part of a system.

electro-hydraulic actuators

- Actuator acts as an additional pressure source
- operated around 0 rpm
- leakage results in non-linear behaviour
- severe friction increases control problems

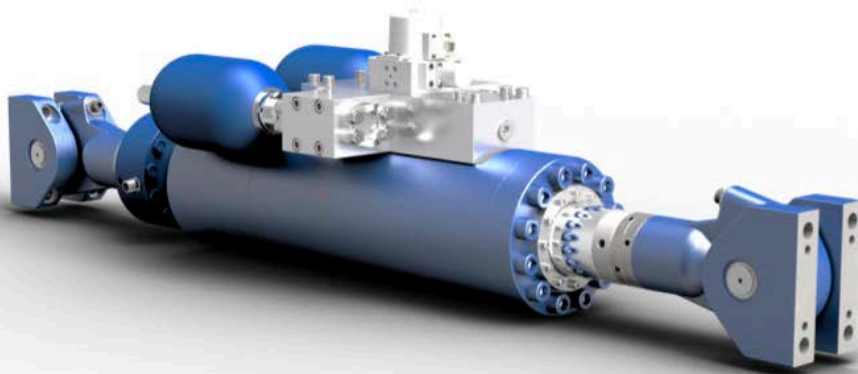

A good example are electro-hydraulic actuators.

- In these systems the actuator can act as an additional pressure source.
- Moreover, in these applications, the pumps are often operated around zero rpm.
- Any leakage results in a strong non-linear behaviour of the control of these actuators.
- Moreover, the stick-slip effects result in severe friction at low speeds, thereby further complicating the control. »

systems with accumulators

- hydraulic hybrid drive trains and all other secondary controlled systems
- hydraulic accumulator acts as an additional flow source
- often operated around 0 rpm
- large effects on the sizing and efficiency of the components

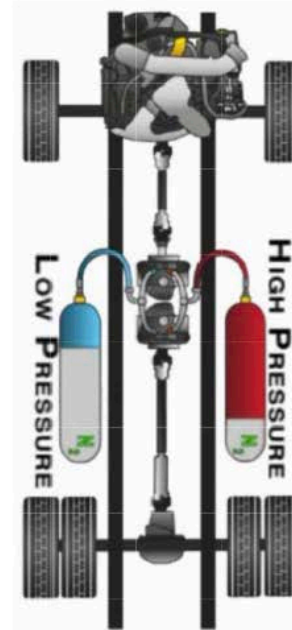

Another example is a hydraulic hybrid vehicle, or any other secondary controlled system, in which the accumulator acts as a second flow source.

Also these systems are often operated around zero rotational speeds.

The strong efficiency reduction at low rpm forces the designers to increase the size of the components, which has a strong detrimental effect on the efficiency.

comparison of 2 pumps and 2 motors

Now to the test results of our new test bench.

I will show you two pumps and two motors. All machines have a displacement of around 30 cc.

2 pumps & 2 motors



The pumps are an axial piston slipper type machine, and a radial piston pump.

The two motors are both slipper type motors from two different suppliers.

It should also be noticed that both Rexroth machines, the A4FO28-pump and the A4FM28-motor, ...

2 pumps & 2 motors

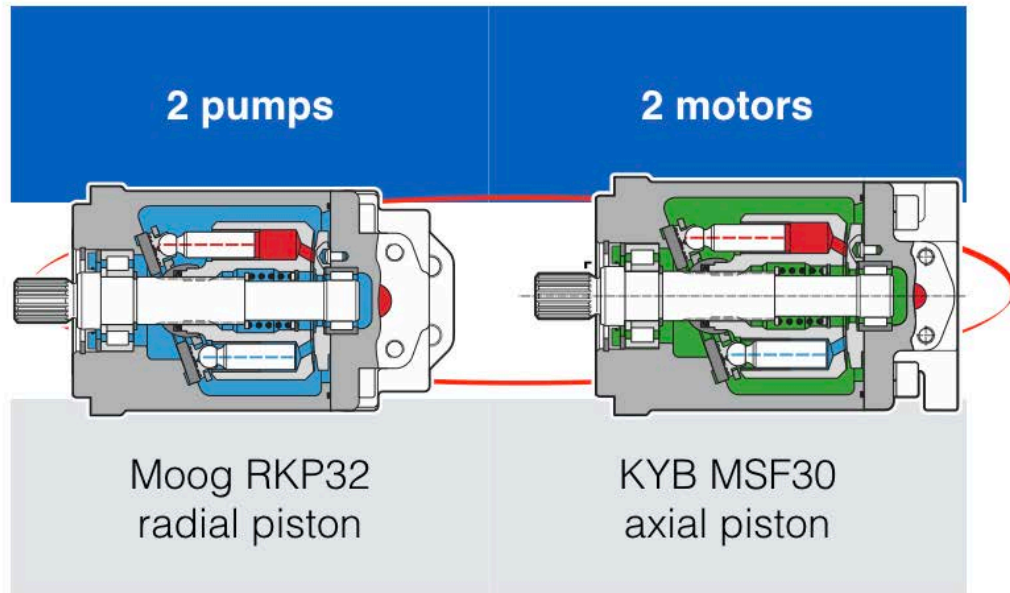

...have almost identical designs.

Torque losses @ 200 bar

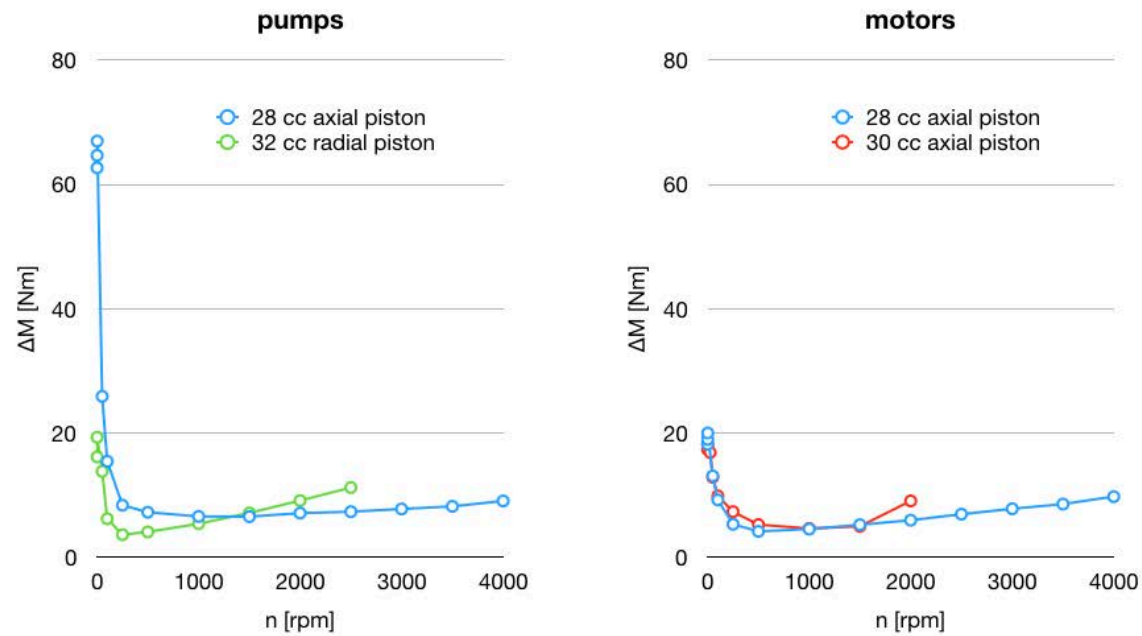

Then, to the results. First the torque losses, measured at 200 bar. The diagram clearly shows some important differences between the axial piston and the radial piston design, especially at very low operating speeds.

In comparison, the two axial piston motors have a much more similar behaviour.

Torque losses @ 200 bar

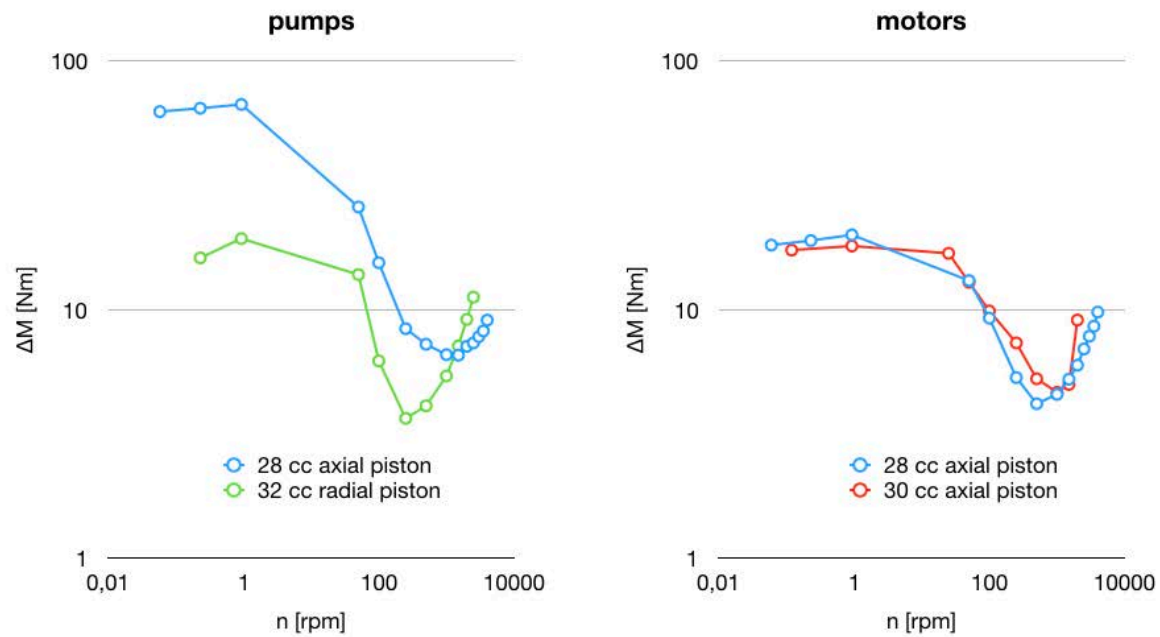

In the log-log-representation, the differences become much clearer.

As before, you can see the significant lower torque losses of the radial piston pump.

Torque losses @ 200 bar

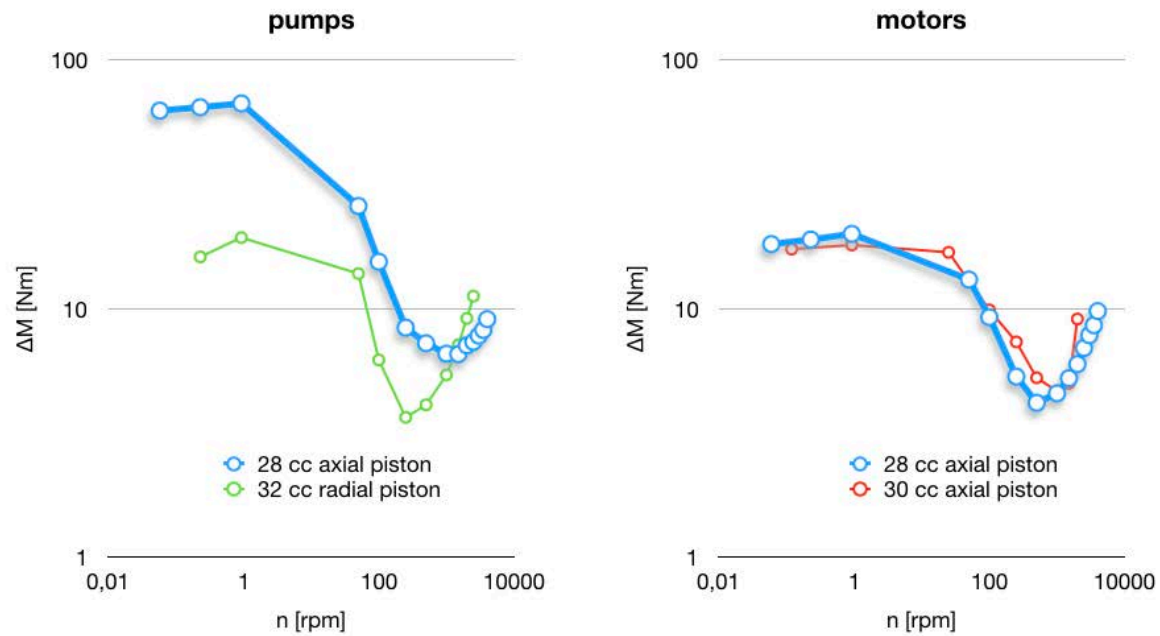

However, our biggest surprise was the large difference between the two Rexroth machines. Although both machines share the same basic configuration, the torque losses as a pump are much higher than as a motor.

case drain @ 200 bar

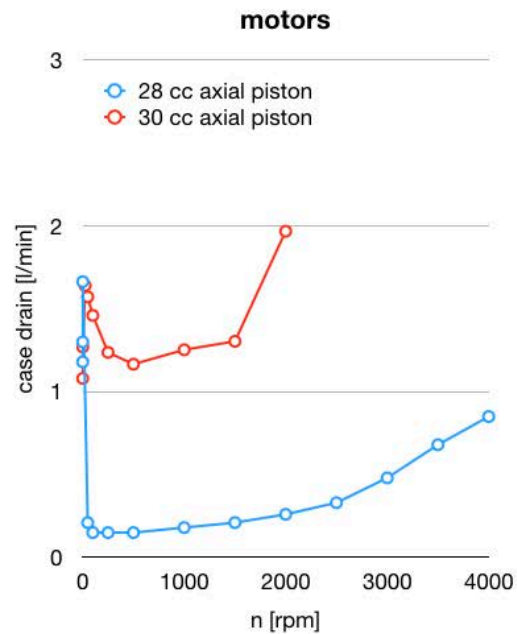
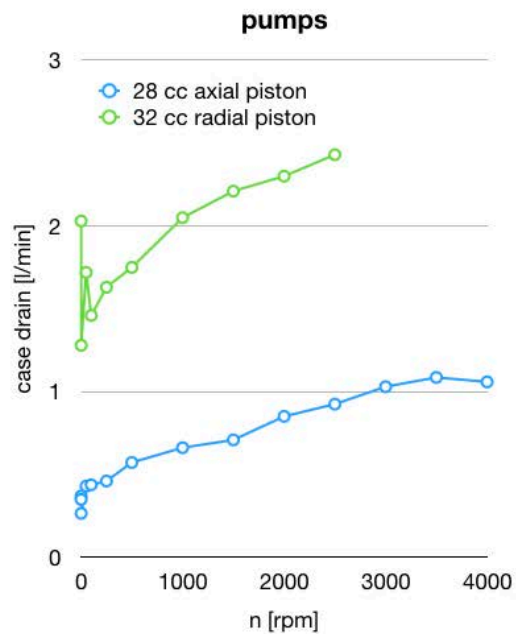

We also measured the volumetric losses at the case drain. Again, there is large difference between the radial piston pump and the axial piston pump. This is to be expected: the radial piston machine does not have a pressure compensated gap in the commutator.

Also between the two axial piston machines there is a large difference. The KYB-motor has a much higher leakage than the Rexroth-motor.

case drain @ 200 bar

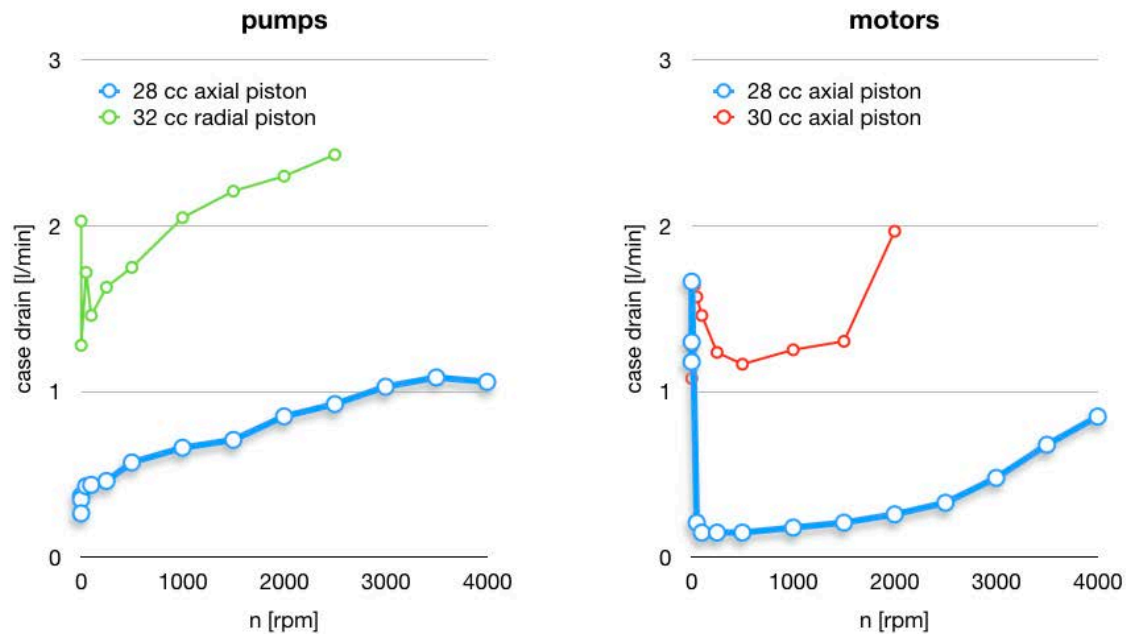

The measurements have also revealed that, as before, there is a significant difference between the two Rexroth machines: as a pump the leakage is much higher than as a motor.

So, we see important differences in the loss behaviour of these hydrostatic machines. Even two machines, which are almost identical, behave very different as a pump or as a motor.

low speed testing (< 1 rpm)

In order to find out more about these differences, we perform low speed tests.

There are several advantages to low speed testing. One advantage is that the centrifugal forces, the impulse forces, viscous friction losses and other speed related forces are reduced to zero. At the same time, the friction in the bearing interfaces is increased due to the elimination of any hydrodynamic lubrication.

To put a simple: low speed testing gives a clear, more or less amplified picture of the friction losses of a machine.

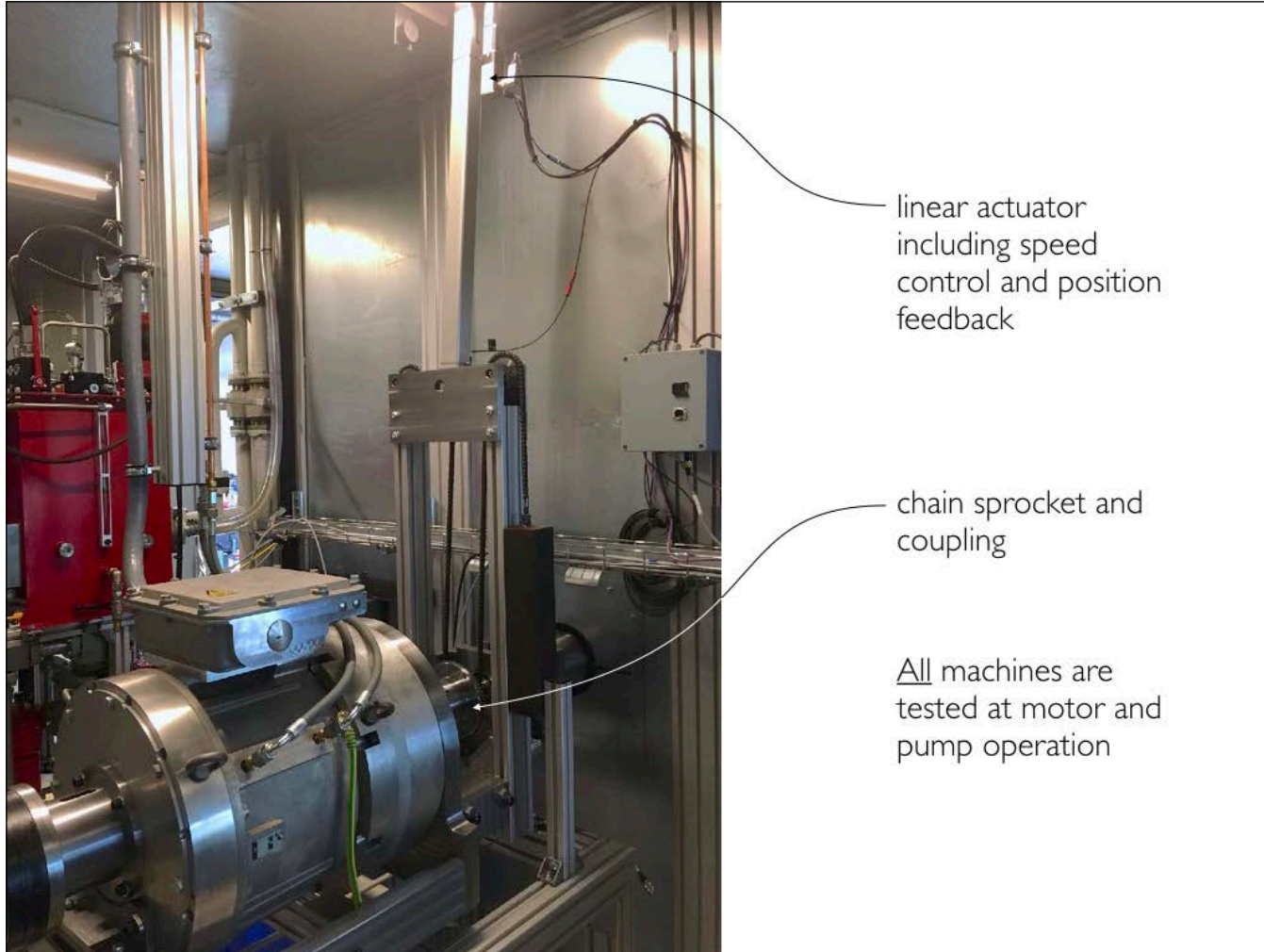

linear actuator
including speed
control and position
feedback

chain sprocket and
coupling

All machines are
tested at motor and
pump operation

This is photograph of our test bench,
showing the linear actuator and the position
of the chain sprocket.

All machines are tested at low operating
speeds as a pump and as a motor,
regardless if the machine being tested is
meant to be a pump or a motor.

case drain A4FM28 @ 400 bar

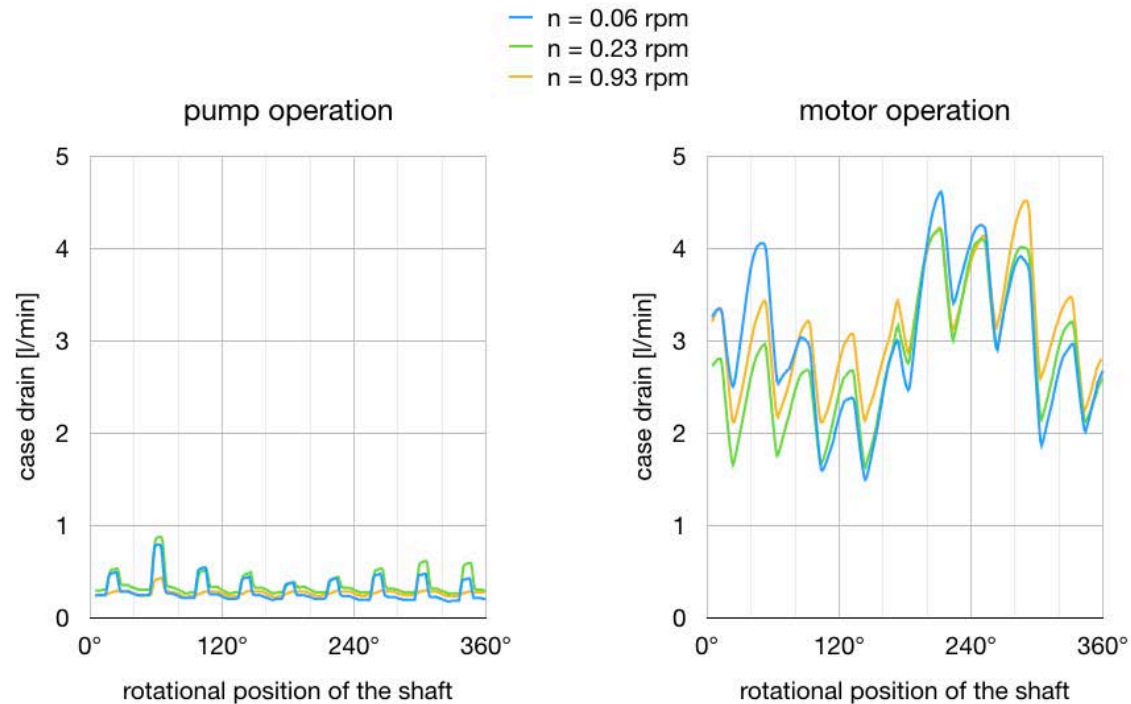

With this test bench, we can precisely measure the losses in a hydraulic machine at low rotational speeds.

This is one of the test results I want to share with you. The diagram on the left shows the test of the Rexroth slipper type motor, being tested as a pump. The machine is measured at about 1 rpm, 1/4 of a rpm and 1/16 of a rpm.

As you can see there are nine pulses, which corresponds with the nine pistons of this machine.

The second diagram, on the right, shows the same machine, but now being tested as a motor. The leakage has dramatically increased. Also, the variation during one single revolution has increased.

Torque loss A4FM28 @ 400 bar

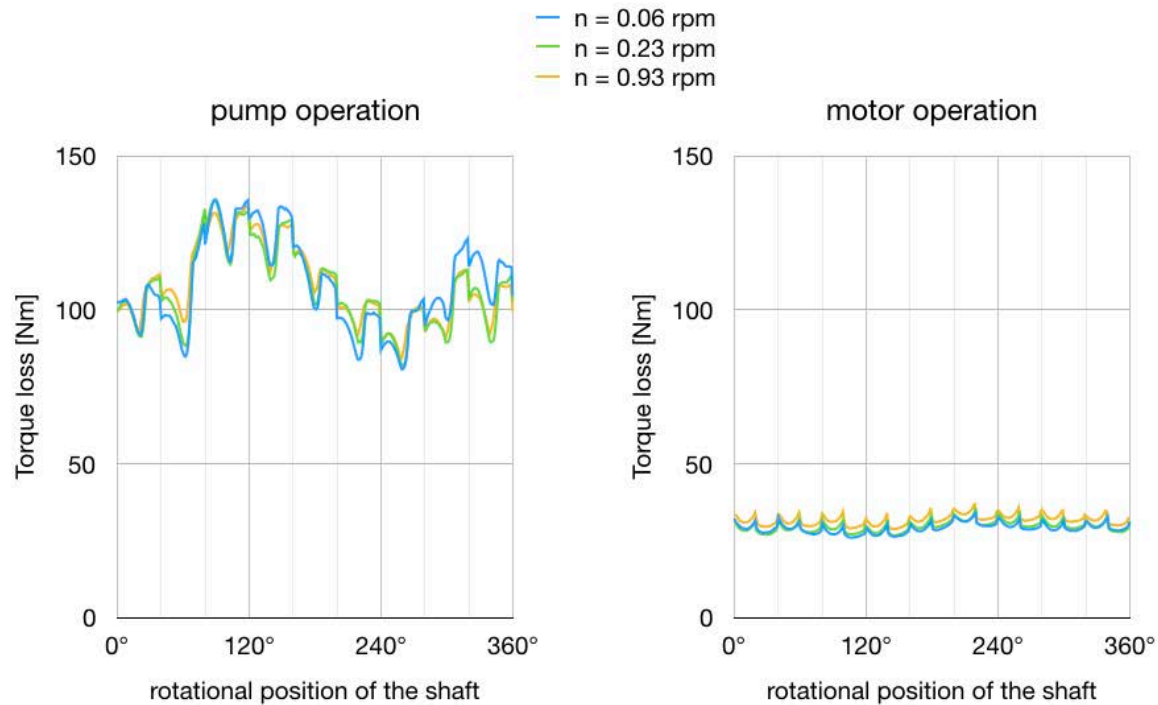

If we look at the torque losses, we see an extremely high friction torque during pump operation. At 400 bar, the theoretical torque is around 170 Nm. But, due to the friction, the machine nearly doubles the required drive torque to nearly 300 Nm.

However, when tested as a motor, the torque loss suddenly decreases by a factor of three to four.

performance 28 cc axial piston motor at low rpm

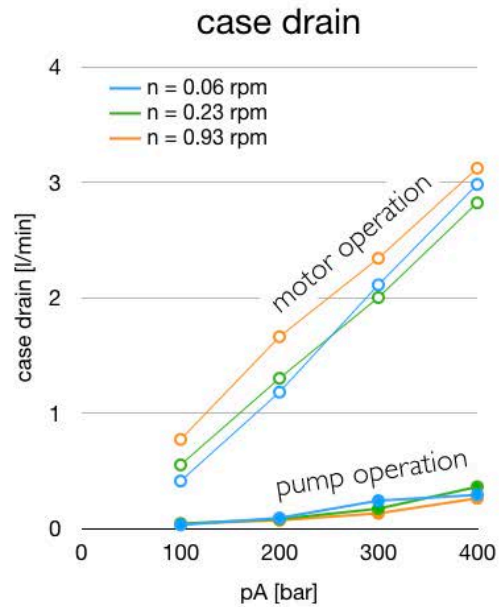
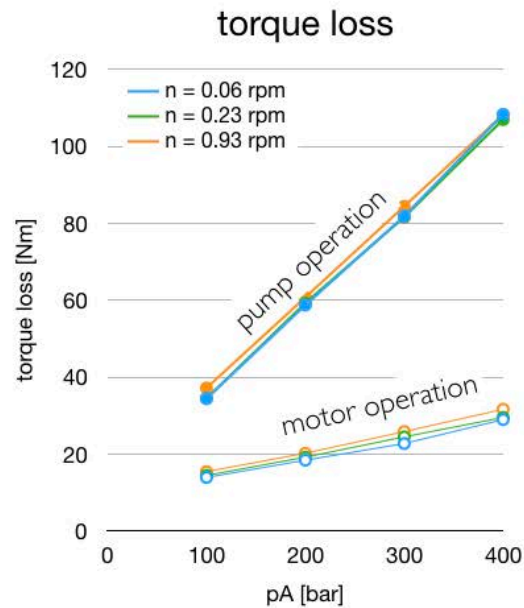

This reduction of torque losses at low rpm is a general trend, which we have seen at almost all piston machines we have tested. Motor operation at low rpm results in low torque losses, but also in high volumetric losses.

future tests

In the following years we will present more of these results.

more performance tests

- bent axis pumps and motors
- internal and external gear pumps
- gerotor and geroler motors
- and more...

We plan to test many more motors and pumps.

floating cup?

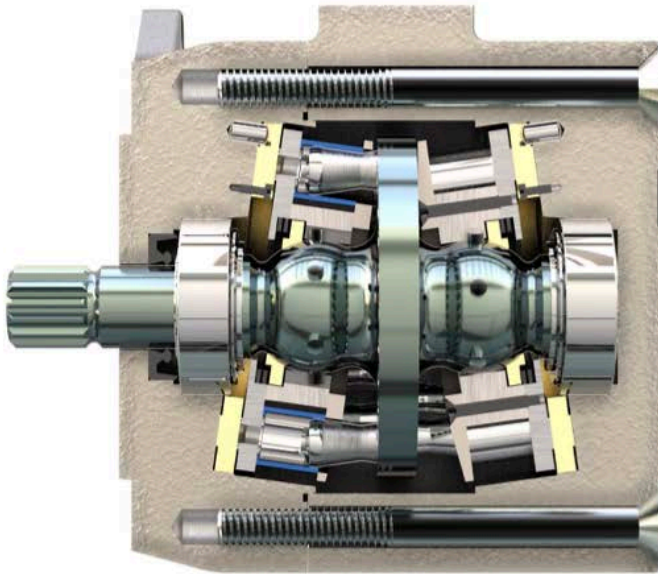

But what about the floating cup principle?

Of course, we did perform a lot of tests on various floating cup pumps and motors. Some results can be found in the paper of this symposium.

Yet, I hesitated to show these results in this presentation.

floating cup?

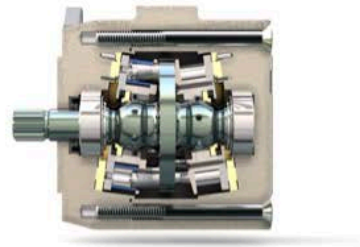

Reviewer comment on the paper:

*“Nevertheless it should be seen that the authors **sole purpose** is to advertise his pump while trying to show scientific findings.”*

The reason for this, is the comment we received from one of the reviewers.

I quote:

“Nevertheless it should be seen that the authors sole purpose is to advertise his pump while trying to show scientific findings.”

This is a very harsh comment. The reviewer tells us that we are not showing scientific findings, we are only trying to. And the » SOLE purpose of our work is to advertise our pump!”

This comment encouraged me to find a creative solution. So, let me end this presentation...

time for a commercial



...with a commercial!

Torque losses @ 200 bar

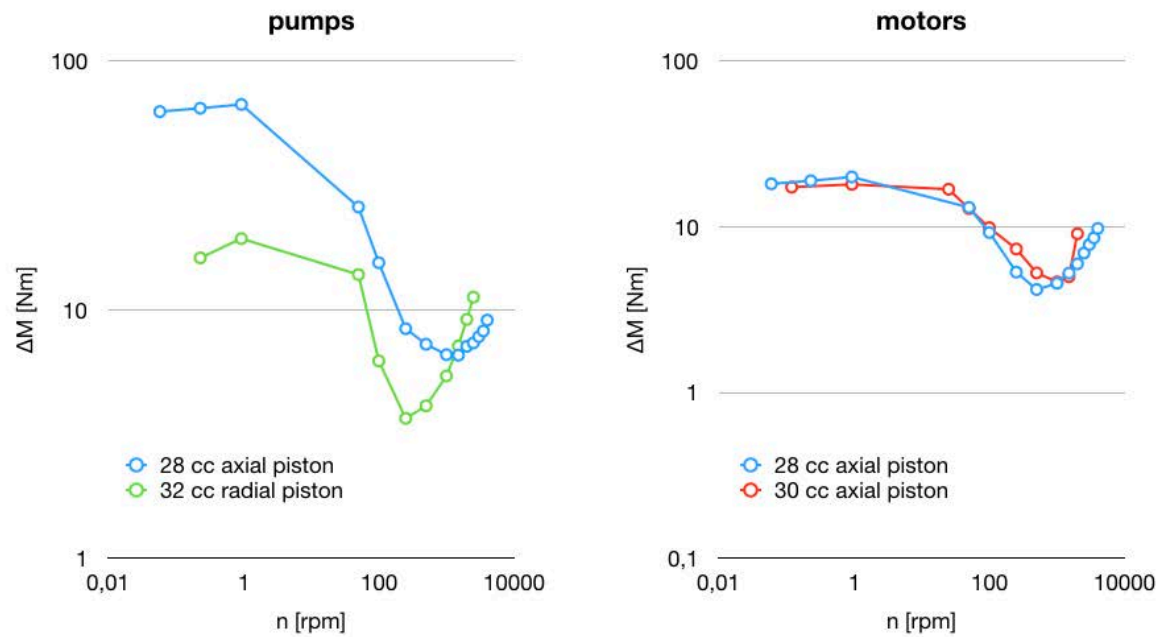

These are the results I showed to you before for the slipper type machines and radial piston pump. These are the log-log-diagrams of the torque losses.

Now let me include the test data for the floating cup...

Torque losses @ 200 bar

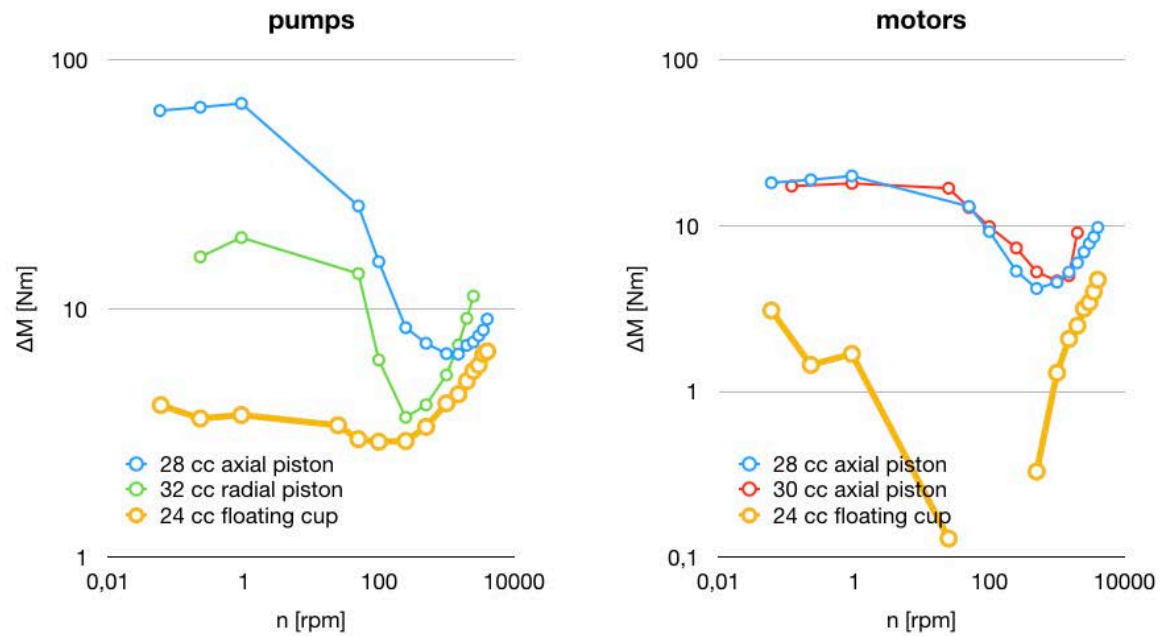

The floating cup principle strongly reduces friction. For rotational speeds below 100 rpm, the losses are even decimated.

case drain @ 200 bar

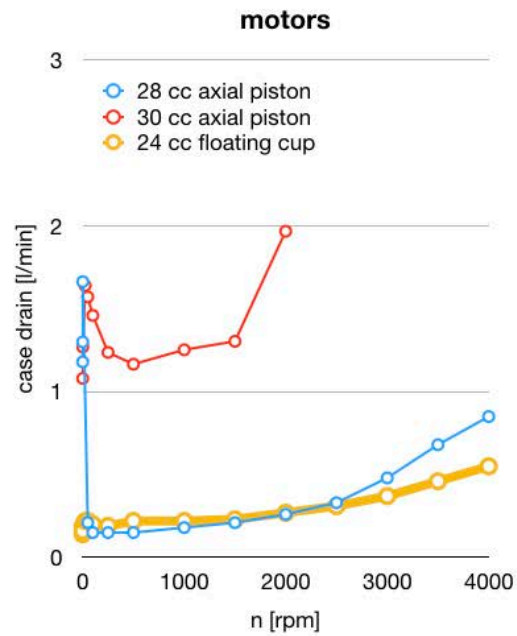
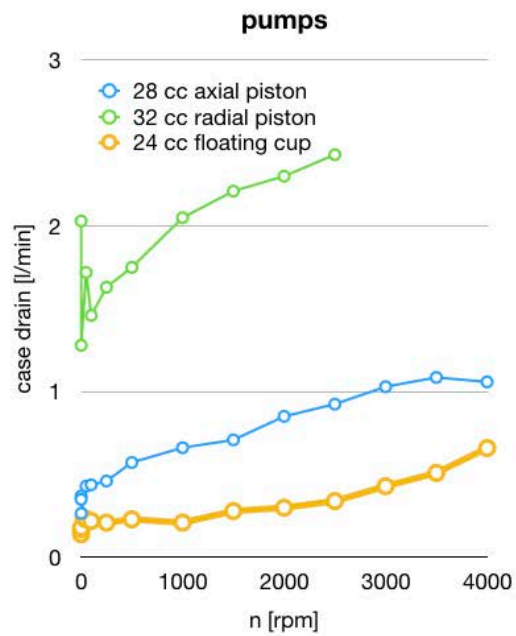

Also the volumetric losses of the floating cup pump and motor are lower than most other machines. In the best point, the floating cup machine has an overall efficiency of 98%, much higher than of the other machines.

floating cup?

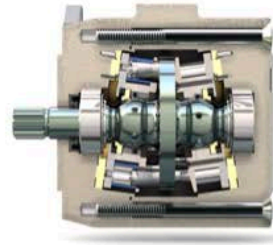

Reviewer comment on the paper:

“Nevertheless it should be seen that the authors sole purpose is to advertise his pump while trying to show scientific findings.”

Dear reviewer:

We are not trying to show scientific findings, we are presenting scientific findings.

And yes, we think we found a new solution and a new product, which will hopefully benefit the whole hydraulic industry.

But, dear reviewer, that isn't the same as advertising. That is the final goal of modern science.

Let me end this presentation by quoting Yuval Harari again:

Modern science

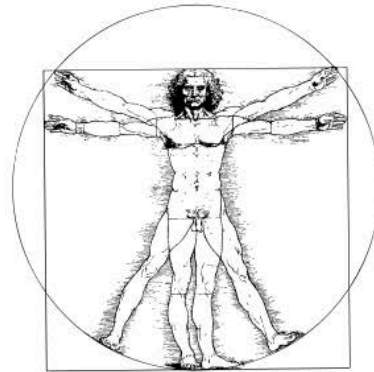

“Modern science is not content with creating theories. It uses these theories in order to acquire new powers, and in particular to develop new technologies.”

“Modern science” he says “is not content with creating theories.”

“It uses these theories in order to acquire new powers, and in particular to develop new technologies.”

That is precisely what we do. Thank you for your attention, and I’m looking forward to the debate! »