

Free-Body Exercises: Linear Motion

In each case the rock is acted on by one or more forces. All drawings are in a vertical plane, and friction is negligible except where noted. Draw accurate free-body diagrams showing all forces acting on the rock. LM-1 is done as an example, using the "parallelogram" method. For convenience, you may draw all forces acting at the center of mass, even though friction and normal reaction force act at the point of contact with the surface. Please use a ruler, and do it in pencil so you can correct mistakes. Label forces using the following symbols: w = weight of rock, T = tension, n = normal reaction force, f = friction.

LM-1. Equilibrium (Example)

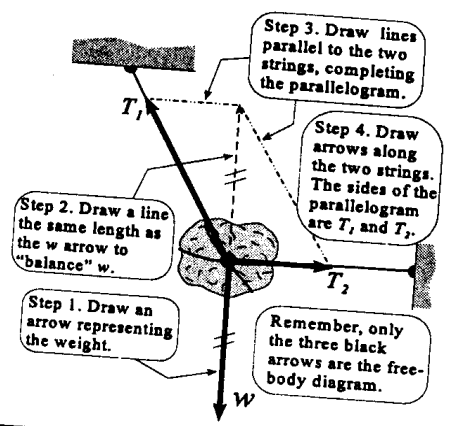

LM-2. Equilibrium

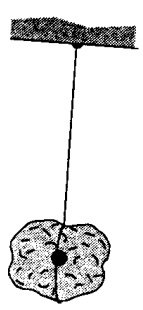

LM-3. Friction prevents sliding.

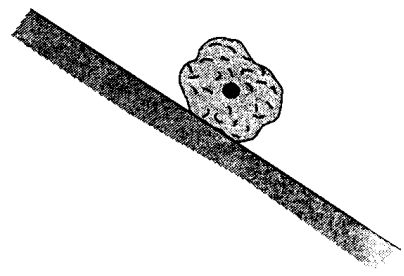

LM-4. Equilibrium

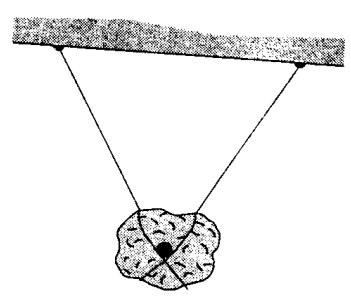

LM-5. Equilibrium

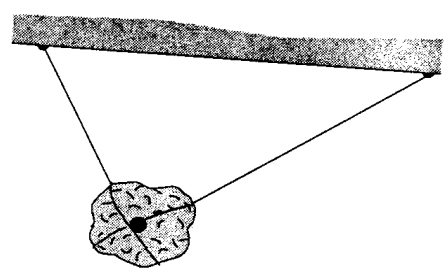

LM-6. Equilibrium

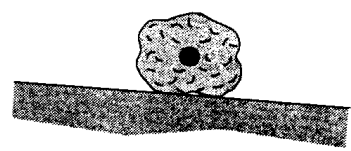

LM-7. Equilibrium

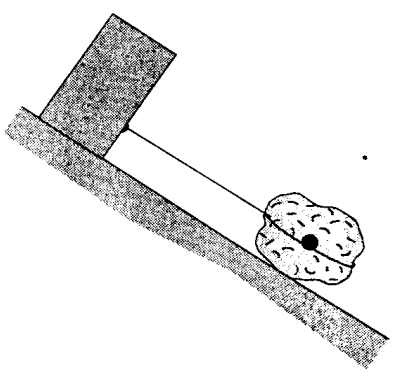

LM-8. Equilibrium

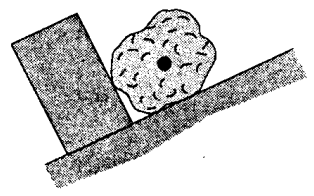

LM-9. Rock is sliding on a frictionless incline.

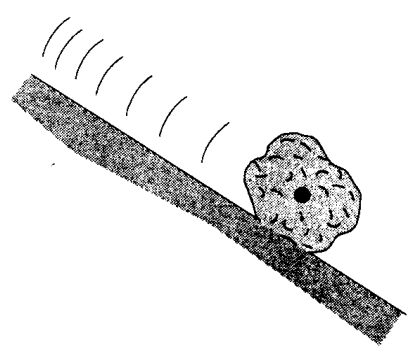

LM-10. Rock is falling. No friction.

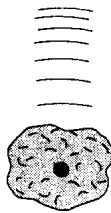

LM-11. Rock is sliding at constant speed on a frictionless surface.

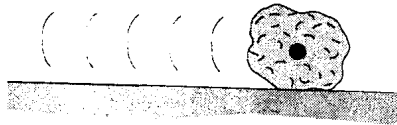

LM-12. Rock is falling at constant (terminal) velocity.



LM-13. Rock is decelerating because of kinetic friction.

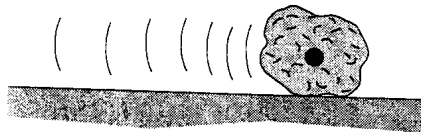

LM-14. Rock is rising in a parabolic trajectory.

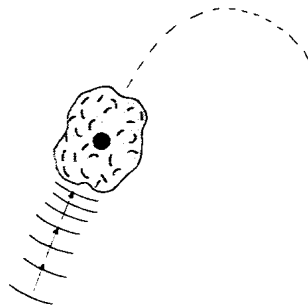

LM-15. Rock is at the top of a parabolic trajectory.

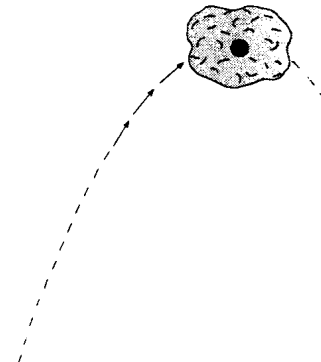

LM-16. Rock is tied to a rope and pulled straight upward, accelerating at 9.8 m/s^2 . No friction.

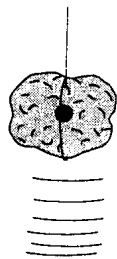

LM-17. Rock is tied to a rope and pulled so that it moves horizontally at constant velocity. (There must be friction.)

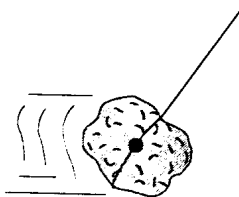

LM-18. Rock is tied to a rope and pulled so that it accelerates horizontally at $2g$. No friction.

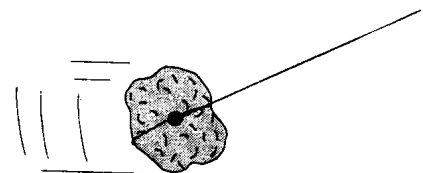

Free-Body Solutions: Linear Motion

The dashed arrows and construction lines in these solutions are for explanation only, and **not** part of the finished diagram. The free-body diagram in each case consists of only the dark, solid arrows. Forces of the same magnitude or lines of the same length are indicated by the same number of "tick" marks drawn through the two lines or arrows. Symbols: w = weight, T = tension, n = normal reaction force, f = friction.

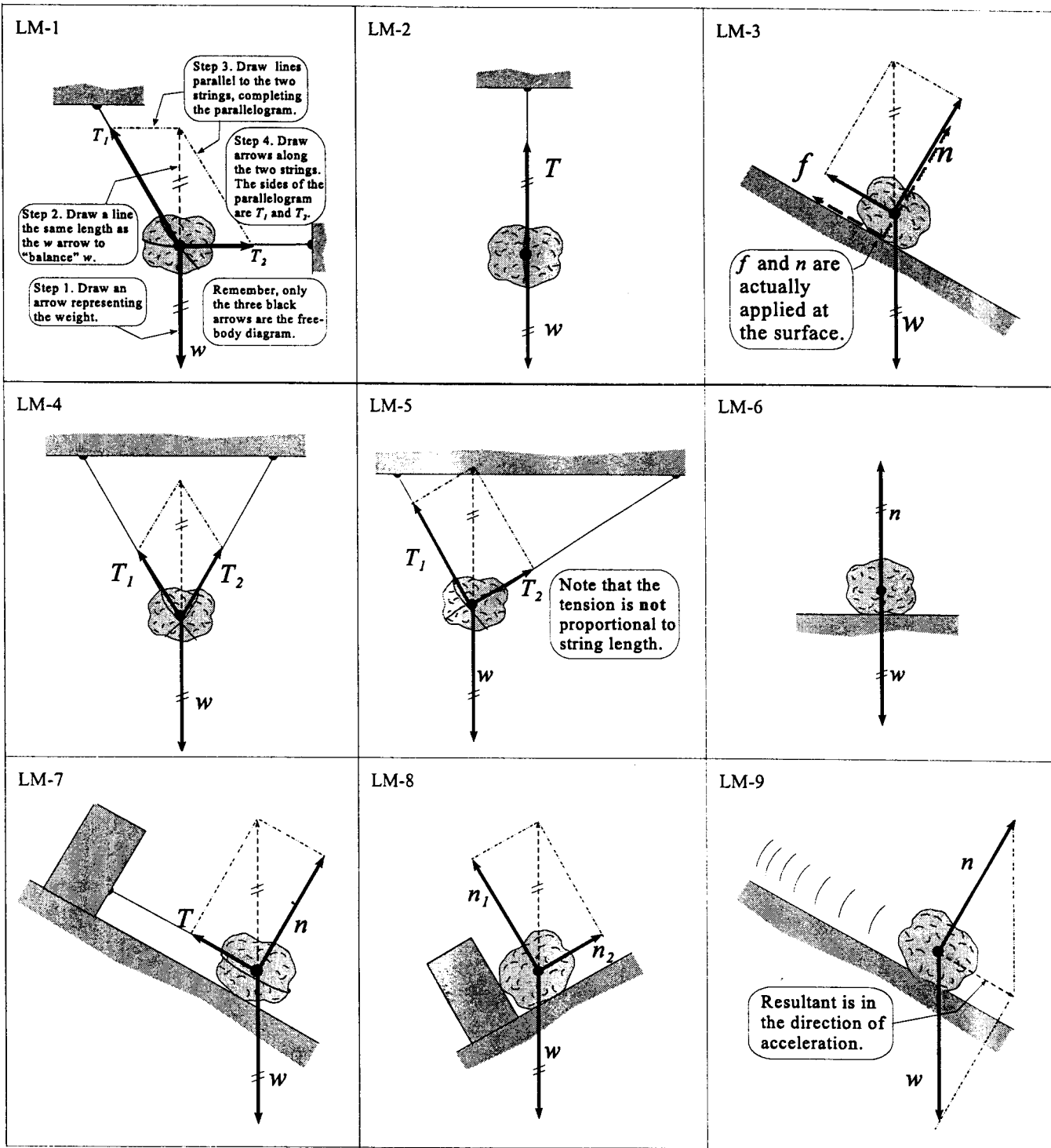

LM-10

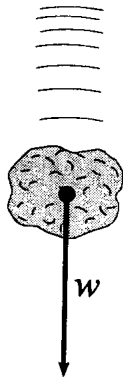

LM-11

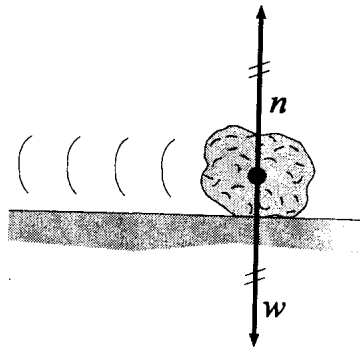

LM-12

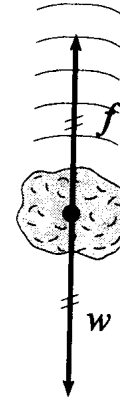

LM-13

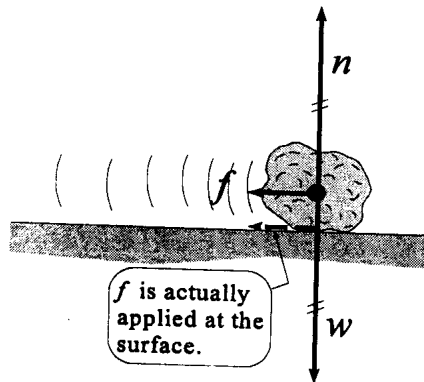

LM-14

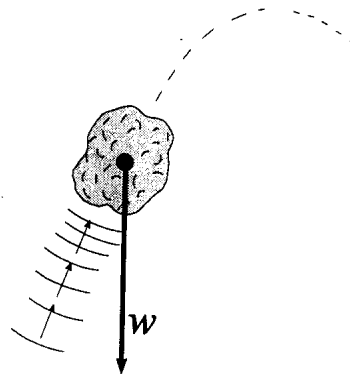

LM-15

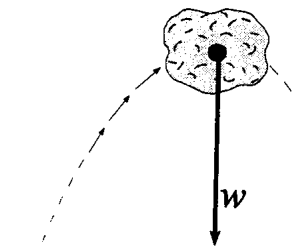

LM-16

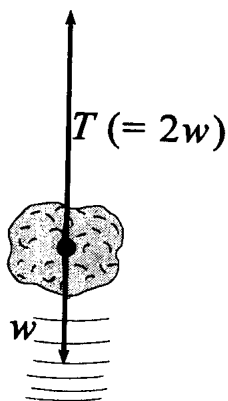

LM-17

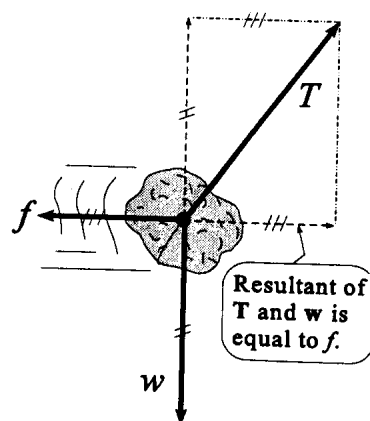

LM-18

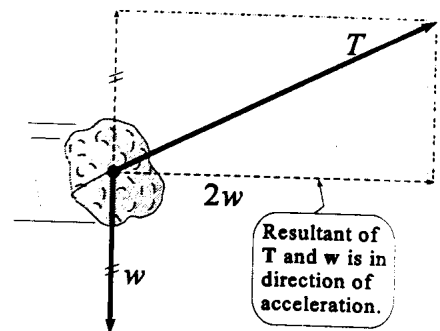

Free-Body Exercises: Circular Motion

Draw free-body diagrams showing forces acting on the rock, and in each case, indicate the centripetal force. Please note that the rock is **not** in equilibrium if it is moving in a circle. The centripetal force depends on angular velocity and there may not be any indication of exactly how big that force should be drawn. Symbols: w = weight, T = tension, f = friction, n = normal reaction force, F_c = centripetal force.

CM-1. Swinging on a rope, at lowest position. No friction.

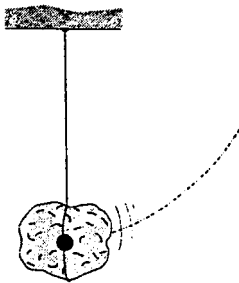

CM-2. Tied to a post and moving in a circle at constant speed on a frictionless horizontal surface. Moving straight out of the paper.



CM-3. String is tied to a post. Rock is moving toward you in a horizontal circle at constant speed. No friction.

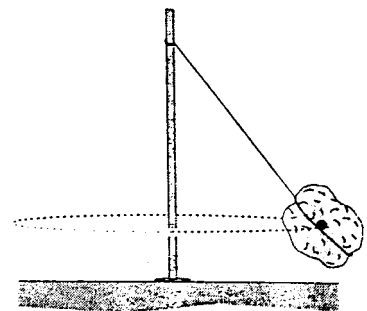

CM-4. Rock is swinging on a rope. No friction.

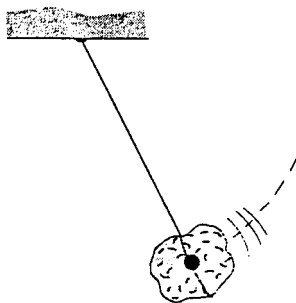

CM-5. Rock is moving downward in a vertical circle with the string horizontal.

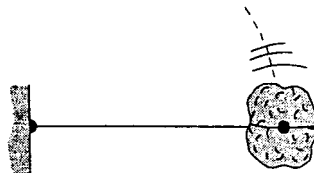

CM-6. Rock is swinging on a rope, at the top of a vertical circle. No friction.

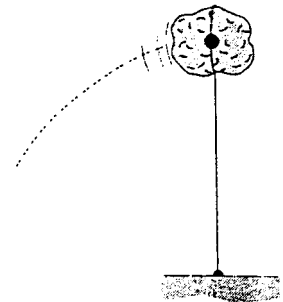

CM-7. Rock is riding on a horizontal disk that is rotating at constant speed about its vertical axis. Friction prevents rock from sliding. Rock is moving straight out of the paper.

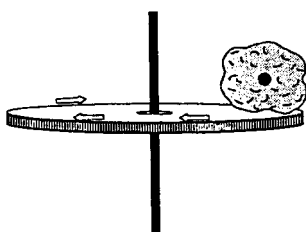

CM-8. Rock is resting against the frictionless inside wall of a cone. It moves with the cone, which rotates about its vertical axis at constant angular speed.

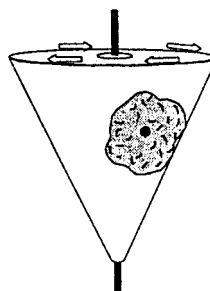

CM-9. Rock is stuck by friction against the inside wall of a drum rotating about its vertical axis at constant speed. Rock is moving straight out of the paper.

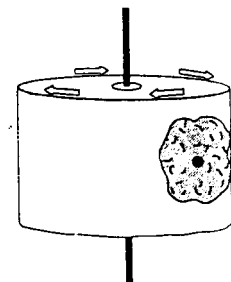

Free-Body Solutions: Circular Motion

Symbols: w = weight, T = tension, f = friction, n = normal reaction force, F_c = centripetal force.

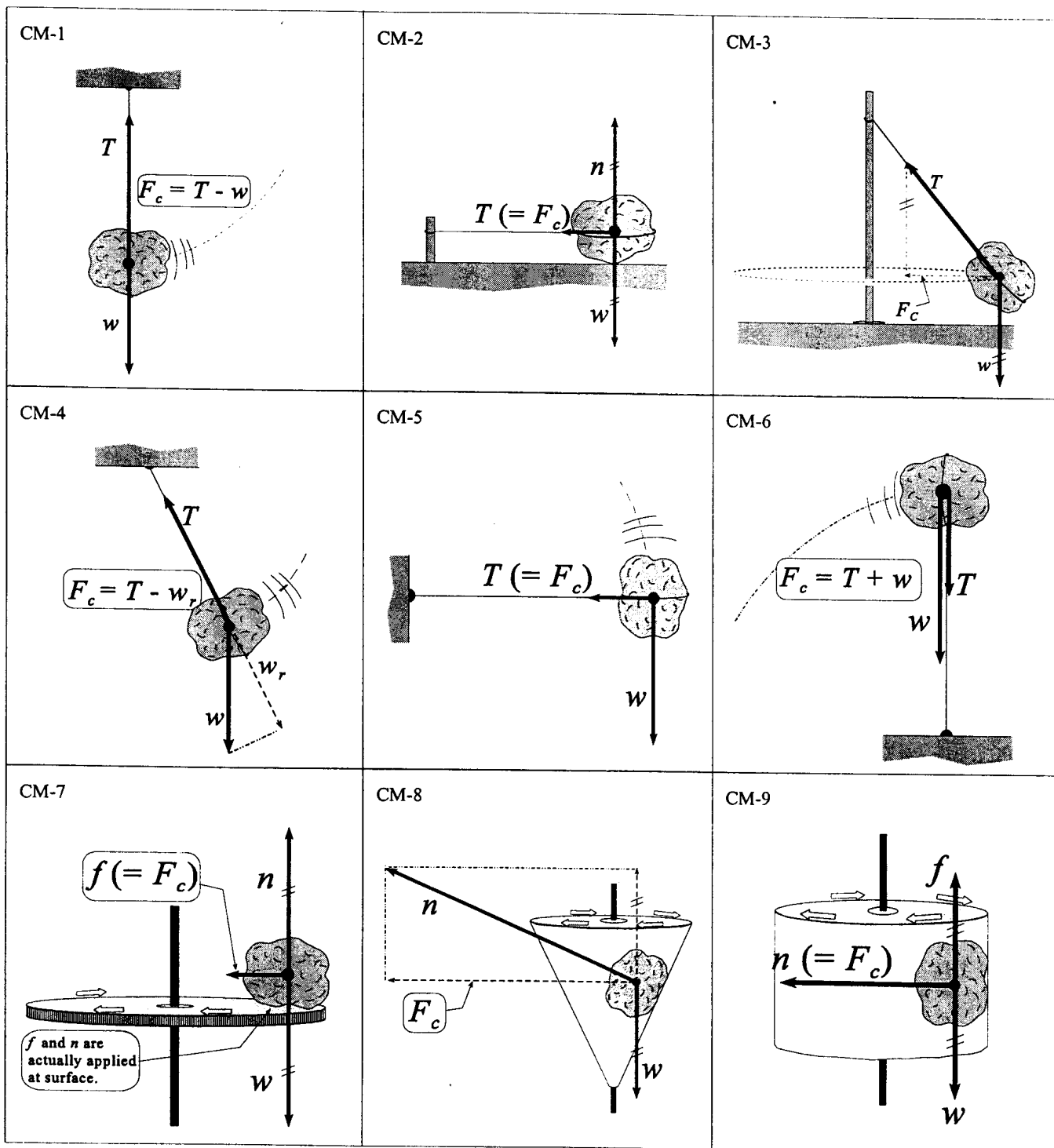

Exercises in Drawing and Utilizing Free-Body Diagrams

Kurt Fisher, Division of Natural Sciences and Mathematics, Dowling College, Oakdale, NY 11769-1999; fisherk@dowling.edu

Students taking the algebra-based introductory physics course often have great difficulty setting up Newton's second law equations of motion for dealing with one-body and two-body problems in particle mechanics. A prerequisite for doing so is the analysis of all the relevant forces, both the visible ones (those indicated or identified as applied forces) and the unseen ones such as gravity and friction. In turn, the tool for this force analysis is the free-body diagram (FBD).

It would seem that if FBD's were introduced, and their application to the generation of the required equations of motion illustrated, the class would readily catch on. Unfortunately, it doesn't work that way. The analysis of forces is dependent on their being correctly perceived. The excellent free-body scale-drawing exercises by J. E. Court¹ are useful for developing the concepts of vector resolution and force analysis. They can be used to firm up a student's understanding of FBD construction to accurate scale, thereby giving insight as to how weight, normal force, and tension force vectors relate to one another. They are also helpful in diagnosing the persistence of the naïve "motion implies force" concepts that students have so much trouble shedding.

But FBD's alone are not enough! There must be the follow-through of utilizing them. The short cut of groping for formulas and numbers to plug into them is seemingly too irresistible. Nonetheless, most problems cannot be solved correctly without due analysis and, in any case, an analytical attitude should be fostered as one of the main goals of education.

When required to include an FBD with a problem, many students draw a perfunctory diagram that looks like a fully loaded pincushion. Vectors are mis-oriented, unlabeled, and/or show no directions. Such an FBD obviously cannot be used to proceed to the equation of motion. Yet, even the students who get the FBD correct *do not use it* further and will write an equation of motion that obviously does not follow from their FBD, thereby defeating its very purpose. I can only ascribe this resistance to analysis as the manifestation of a learning style that stems from the "show-and-tell" methodology and the avoidance of word problems and other integrative activities.

The small set of exercises offered here (Fig. 1) shows how I try to habituate the student to the analysis steps needed to successfully work out problems in particle dynamics. The idea is to present a series of graded exercises in identifying forces, have the student install them on an FBD, and then take the next step—write down the ΣF equations following from the analysis. Inherent in these exercises is the redundancy necessary for the learner to internalize the process. I have been using these exercises since returning from the 1993 Rensselaer conference.² I bundle them together with the aforementioned Court exercises and distribute them soon after starting the mechanics chapter. My students are given a three-week window in which to work both sets of exercises and submit them for homework credit. One revision is permitted. Parts of these exercises appear on tests, so the value of working them out is appreciated by the students.

To introduce my students to this multi-step procedure, three or four of the exercises are worked out in class using Socratic dialogue as much as possible. I emphasize that writing expressions for ΣF_x and ΣF_y is an indispensable prerequisite to solving one- and two-body mechanics problems. This is where these exercises go a step beyond those that solely involve drawing FBD's. For each case the ΣF_x expression is carried out as far as possible. This means that, in the cases where friction is taken into account, it is necessary to substitute into the ΣF_x expression the normal force yielded by the $\Sigma F_y = 0$ equation (we always assume that there is no motion in the y -direction).

A very useful aid to sorting out the relevant forces in a mechanics problem is the ON/BY table, which I have recently begun to require as part of the solution on tests. The idea for this table came from perusing one of the *Socratic Dialogue Inducing* (SDI) labs,³ another fallout gem traceable to the 1993 Rensselaer conference. It both mirrors and reinforces the FBD; an additional benefit is that it speeds up grading because all the force vector values, magnitudes, and directions are organized in one place. It requires the student to name the body each force acts ON and the body BY which that force is exerted.

I can offer only anecdotal perceptions to indicate that a larger fraction of my class takes the solutions to standard mechanics problems farther than before. For more exercise samples, contact me by mail or e-mail. I would appreciate any feedback as to results stemming from the deployment of these exercises, and would also welcome any additions or modi-

fications found to improve their effectiveness.

References

1. James E. Court, *Phys. Teach.*, **31**, 104 (1993).

2. Conference on the Introductory Physics Course (May 1993). The proceedings of this landmark conference have been published by John Wiley & Sons, under the auspices of Rensselaer Polytechnic Insti-

tute and the National Science Foundation (edited by Jack Wilson, ISBN 0-471-15557-8).

3. Richard R. Hake. private communication; See also *Phys. Teach.* **30**, 546 (1992).

Graded Exercises in Drawing and Utilizing Free-Body Diagrams

Using a ruler, draw free-body diagrams (FBD's) showing all forces acting on each body. Coordinate directions are indicated in the leading diagram of a sequence. Forces that are replaced by their x - and y - components should be shown canceled out. Then using each FBD as a guide, write down the ΣF_x and ΣF_y expressions, carrying them to the point where numerical values might be substituted for F_a , m , θ , ϕ , and μ .

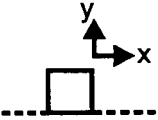
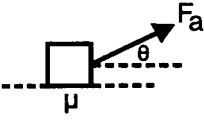
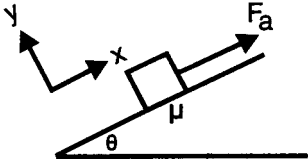
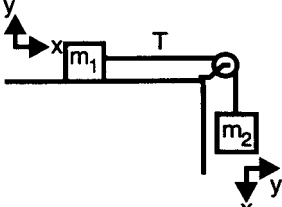
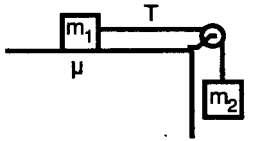
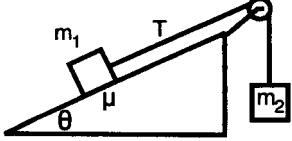
I. ONE-BODY CONFIGURATIONS	F-B Diagram (Show only x - and y -components of all forces acting ON the body)	$\Sigma F_x =$	$\Sigma F_y =$
1. Frictionless level surface.			
2. Level surface with friction. Applied force at an angle θ .			
3. Incline with friction. Applied force parallel to incline. $F_a > W_{//}$			
II. TWO-BODY CONFIGURATIONS (Assume ideal pulleys)	Take the x -axis to lie along the direction of motion of each body. See #4 for the example.	$\Sigma F_x =$	$\Sigma F_y =$
4. m_1 is on a frictionless horizontal surface and is connected to hanging mass m_2 by a massless string.		$m_1:$ $m_2:$	$m_1:$ $m_2:$
5. Same as #4 except that m_1 experiences friction.		$m_1:$ $m_1:$	$m_1:$ $m_2:$
6. m_1 experiences friction. $m_1 \sin \theta > m_2$		$m_1:$ $m_2:$	$m_1:$ $m_2:$

Free-Body Diagrams Revisited – II

James E. Court, City College of San Francisco, San Francisco, CA 94112

[Editor's Note: We reproduce here a continuation of the collection of free-body exercises sent us by Jim Court, the first part of which was published in October. At the request of Jim's widow, a colleague and friend of the author, Paul Hewitt (One San Antonio Place – 2D, San Francisco, CA 94113-4032), is acting as Jim's representative in this important contribution to the teaching of physics.]

Free-Body Exercises: Rotational Equilibrium

All of the beams and the packages have the same weight w , and they are "uniform," which means the weight can be applied at the center. These systems are in equilibrium, so the net torque, the net vertical force and the net horizontal force are all zero. Symbols: w = weight, T = tension, n = normal reaction force at surface, V = vertical reaction force at hinge, H = horizontal reaction force at hinge, f = friction. RE-1 is done as an example.

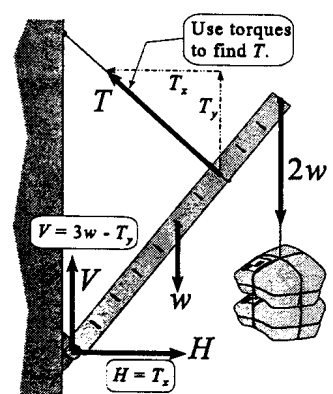
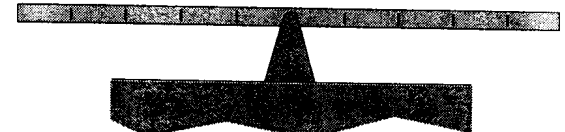
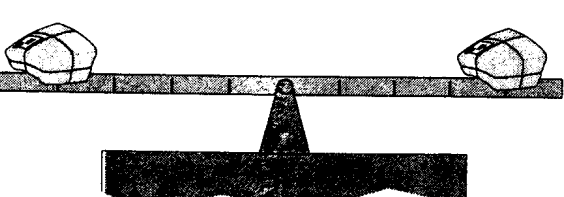
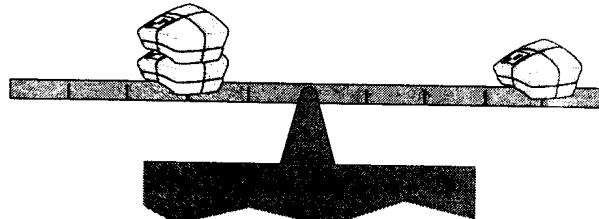
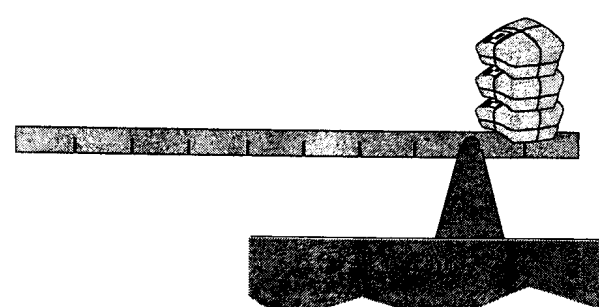
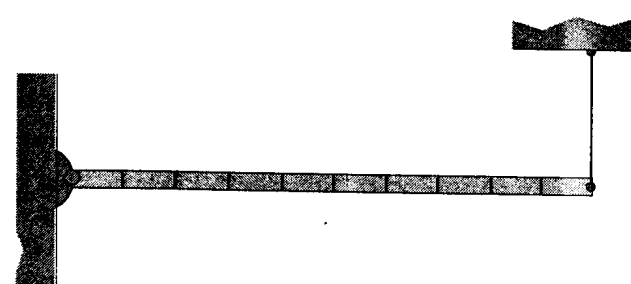
<p>RE-1. Equilibrium</p> 	<p>RE-2. Equilibrium</p> 
<p>RE-3. Equilibrium</p> 	<p>RE-4. Equilibrium</p> 
<p>RE-5. Equilibrium</p> 	<p>RE-6. Equilibrium</p> 

RE-7. Equilibrium

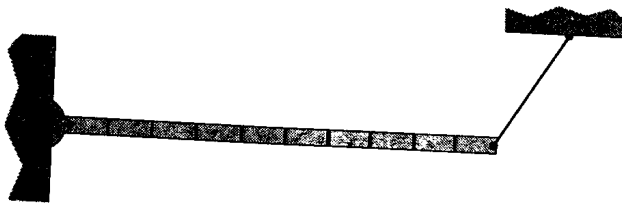

RE-8. Equilibrium

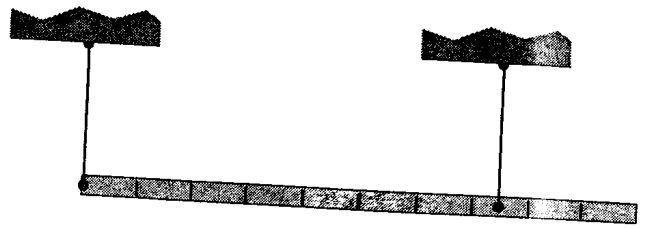

RE-9. Equilibrium

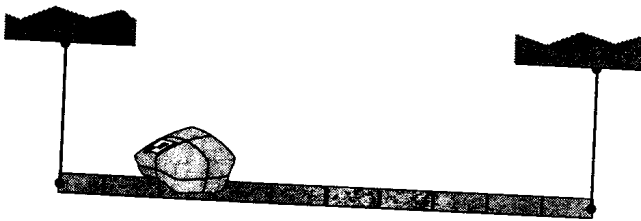

RE-10. Equilibrium

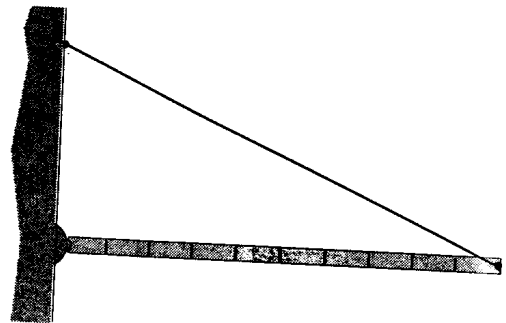

RE-11. Equilibrium

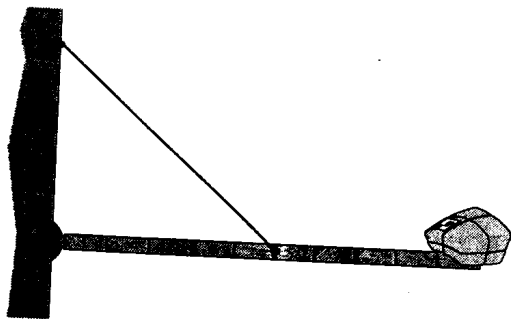

RE-12. Equilibrium

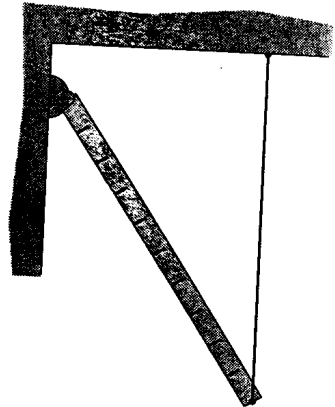

RE-13. Equilibrium

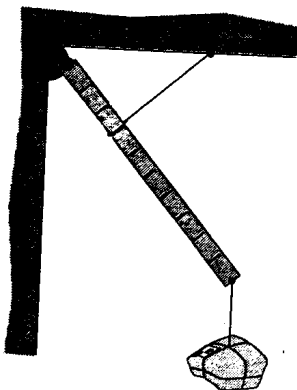

RE-14. Equilibrium; floor is rough, wall is frictionless.

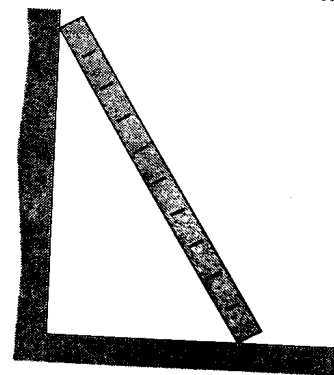

Free-Body Solutions: Rotational Equilibrium

Symbols: w = weight, T = tension, n = normal reaction force at surface, V = vertical reaction force at hinge, H = horizontal reaction force at hinge, f = friction.

<p>RE-1</p> <p>Use torques to find T.</p> <p>$V = 3w - T_y$</p> <p>$H = T_x$</p>	<p>RE-2</p> <p>V</p> <p>w</p>
<p>RE-3</p> <p>$V (= 3w)$</p> <p>w</p> <p>w</p>	<p>RE-4</p> <p>$V (= 4w)$</p> <p>$2w$</p> <p>w</p>
<p>RE-5</p> <p>$V (= 4w)$</p> <p>w</p> <p>$3w$</p>	<p>RE-6</p> <p>V</p> <p>w</p> <p>T</p>

RE7

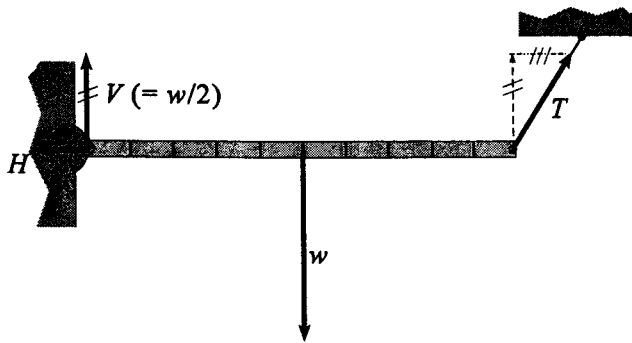

RE-8

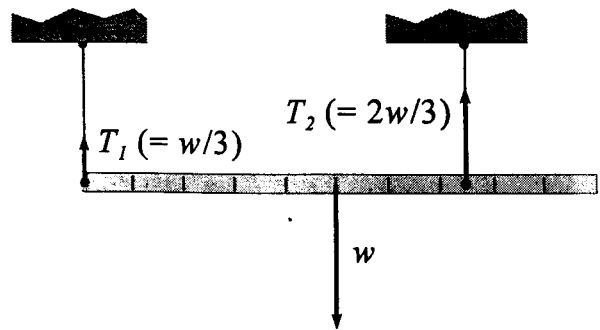

RE-9

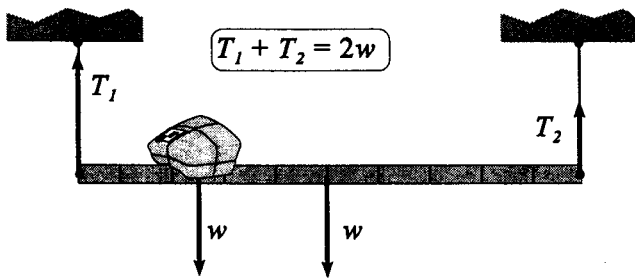

RE-10

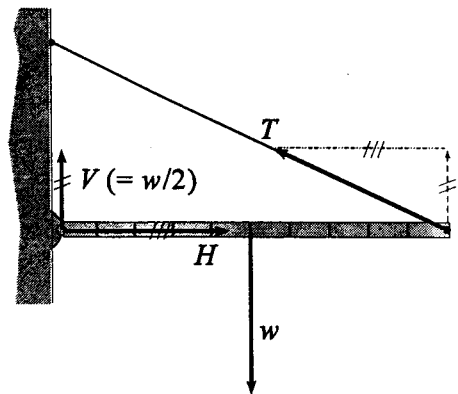

RE-11

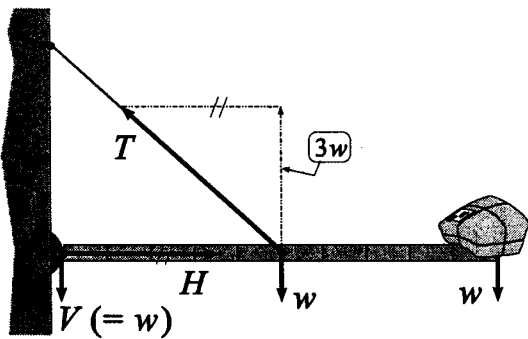

RE-12

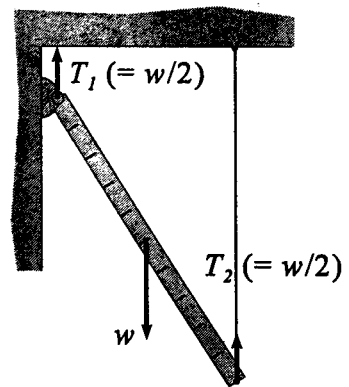

RE-13

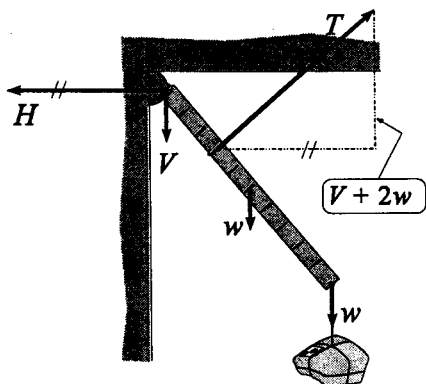

RE-14

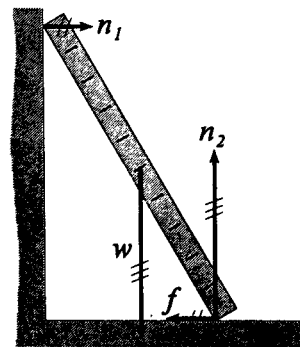

Free-Body Exercises: Rotational Non-equilibrium

In each case, draw arrows representing all forces acting on the cylinder or the beam. The solid, uniform cylinders, the packages suspended from them, and the uniform beams all have the same weight w . In all but one of these examples the object is not in rotational equilibrium, i.e. the torques do not add up to zero. Symbols: T = tension, w and m = weight and mass of cylinders, beams and packages, n = normal reaction force at surface, V = vertical force at hinge or axle, H = horizontal force at hinge, a = acceleration. RN-1 is done as an example.

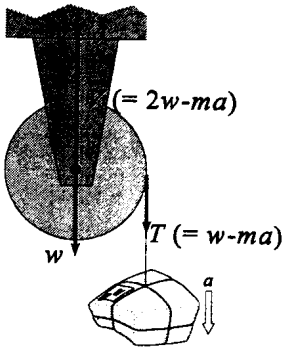
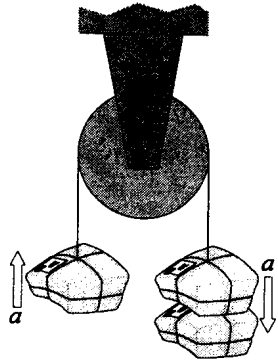
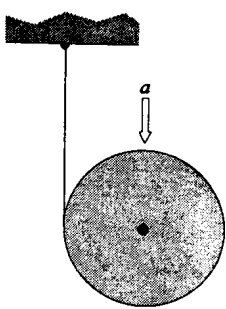
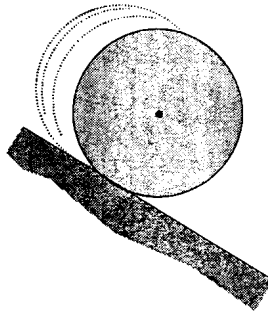
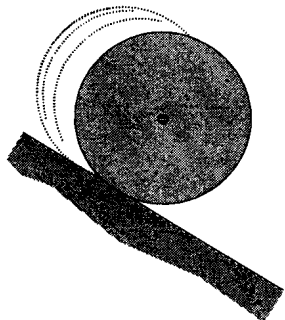
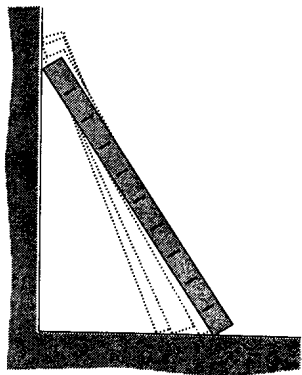
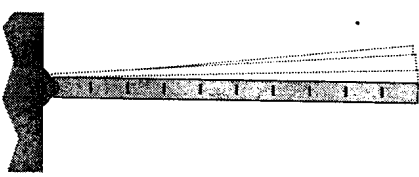
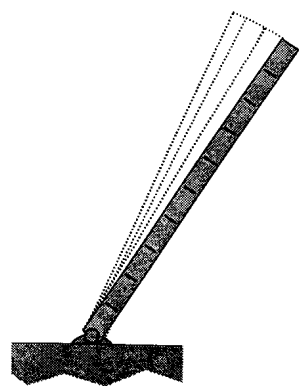
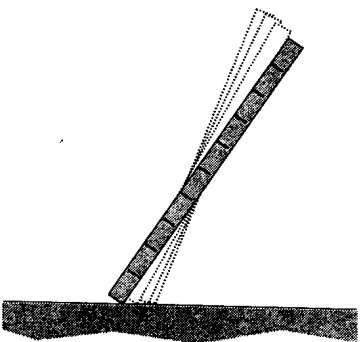
<p>RN-1. Cylinder is supported on a frictionless horizontal axle.</p> 	<p>RN-2. Same as RN-1.</p> 	<p>RN-3. String is tied to ceiling and wrapped around cylinder. Cylinder is falling.</p> 
<p>RN-4. Cylinder is rolling down a rough (not frictionless) incline.</p> 	<p>RN-5. Cylinder was released with zero angular velocity on a frictionless incline. Is it rolling?</p> 	<p>RN-6. Beam is slipping. Both wall and floor are frictionless.</p> 
<p>RN-7. Beam is swinging down through horizontal position.</p> 	<p>RN-8. Beam is swinging downward.</p> 	<p>RN-9. Beam is falling on a smooth (frictionless) floor. If the beam is released from rest, what path does the c of m take?</p> 

Free-Body Solutions: Rotational Non-equilibrium

Symbols: T = tension, w and m = weight and mass of cylinders, beams and packages, n = normal reaction force at surface, V = vertical force at hinge or axle, H = horizontal force at hinge, a = acceleration.

<p>RN-1</p> <p>$(= 2w - ma)$</p> <p>$T (= w - ma)$</p> <p>w</p> <p>a</p>	<p>RN-2</p> <p>$V (= 4w - ma)$</p> <p>$T_1 (= w + ma)$</p> <p>$T_2 (= 2w - 2ma)$</p> <p>a</p>	<p>RN-3</p> <p>$T (= w - ma)$</p> <p>w</p> <p>a</p>
<p>RN-4</p> <p>w</p> <p>n</p> <p>Resultant is parallel to surface.</p> <p>n is actually applied at point of contact.</p>	<p>RN-5</p> <p>w and n both pass through the c of m, so there is no torque. The cylinder slides down hill.</p> <p>Resultant is parallel to surface.</p> <p>n is actually applied at point of contact.</p>	<p>RN-6</p> <p>n_1</p> <p>n_2</p> <p>w</p> <p>n_1 and n_2 change continually as the beam falls.</p>
<p>RN-7</p> <p>V</p> <p>Centripetal force</p> <p>w</p>	<p>RN-8</p> <p>V must be $< w$ because the c of m is accelerating downward.</p> <p>H must initially be to the right because the c of m is accelerating in that direction. What about later?</p> <p>w</p> <p>V</p> <p>H</p>	<p>RN-9</p> <p>n must be $< w$ because the c of m is accelerating downward.</p> <p>c of m must accelerate straight downward because there is no horizontal force.</p> <p>w</p> <p>n</p>