



Fine Turnings

American Association of Woodturners, Seattle Chapter, May, 2016

From the President

I would like to thank all the mentors last month for answering questions from the members. There were many things sold at the "Tool Swap"; some people brought in pictures of larger items that were for sale. Those items can be sent to Les for inclusion in the Want Ads section of the newsletter.

This month's demonstrator is Michael Dresdner on finishing. I am not sure what he will be doing but I'm excited to always learn something new.

Jim Steck is now in charge of the topics at the Saw Dust Sessions. May's Saw Dust Session will be Burt Hovander on making chatter tools for tops and other turnings. More on this later in the newsletter. I have lots of small pieces of wood for turning unless you have special piece that you want to use to turn. There will always be sharpening and other activities that pertain to wood turning. I will continue to host this event each month.

Beads of Courage boxes for children that are dealing with catastrophic illness are NEEDED! This seems to be one of the areas our club has a hard time getting done. This is a really important moral boost for the kids.

Those of you that took wood for making tops at home please bring them in at the meeting. We hope to get to 1000 before July to free up the demonstrators to turn what they choose. There will be more wood at the next meeting.

The club is in the process of doing a complete inventory. Items that have not been used recently and are not expected to be used in the future will be put in a silent auction at a club meeting to free up space in the trailer.

President see page 3



Seattle's AAW Web Site

www.seattlewoodturners.org

May Demonstrator

Michael Dresdner is a nationally known finishing and woodworking expert, the author of *Restoration Clinic*; *The Woodfinishing Book*; *The New Wood Finishing Book*; *Build Like a Pro: Painting and Finishing*, and *Wood Finishing Fixes* as well as four videos and two DVDs on wood finishing.

He appeared as Contributing Editor on the mastheads of *Fine Woodworking Magazine*, *American Woodworker Magazine*, and *Woodworker's Journal*, and was the founder and host of a weekly online finish chat. He wrote the *Just Finishing* column for *American Woodworker Magazine* for over 7 years, and the *Finishing Thoughts* column for *Woodworker's Journal* for more than 12 years. Both were byline columns. During one five year period he wrote answers to

Demonstrator see page 3

2016 CALENDAR SEATTLE AAW

January

- 5** Board Meeting
- 14** AJ Mearns on Coring techniques

February

- 2** Board Meeting
- 11** Tom Johanson- "Turning Magic"

March

- 1** Board Meeting
- 10** Stephen Hatcher
- 12** HandsOn: Stephen Hatcher all day workshop @ AJ's shop **full**

April

- 4** Board Meeting
- 14** Tool Swap and Expert Panel Discussion
- 16** Sawdust Session: Beginning bowls and spindle work

May

- 3** Board Meeting
- 12** Michael Dresdner on Finishing
- 14** Sawdust Session: Chatter Tools w/Burt Hovander
- 31** June Board Meeting

June

- 9** John Shrader
- 11** Sawdust Session: TBD with David Lutrick

July

- 5** Board Meeting
- 14** Mini Demonstrations by members
- No Sawdust Session

August

- 2** Board Meeting
- 11** TBD
- 30** Sept Board Meeting
- No Sawdust Session

September

- 8** Russel Neyman, Brad Stave "Fifty Nifty"
- 10** Sawdust Session: TBD
- Nominations Committee for Club Officers is formed

October

- 4** Board Meeting
- 13** Eric Lofstrom
- 15** Sawdust Session: Lofstrom hands-on

November

- 1** Board Meeting
- 10** Annual Elections & Reed Gray
- 12** Sawdust Session: Moe and Johnson Ornaments class (tentative)

December

- 8** Christmas Party
- No Sawdust Session

Demonstrator from page 1



over 8,000 questions for the www.woodanswers.com blog, and edited the *Woodworker's Journal eZine*, an award-winning online woodworking magazine with over a quarter of a million subscribers.

In the past, he also has written byline columns for *String Instrument Craftsman*, *The Wood Post*, *Vintage Guitar Bulletin*, and the *Sound Advice* column for *American Lutherie* magazine. He has written thousands of articles and columns for a variety of books and magazines including *This Old House Magazine*, *Fine Woodworking Magazine*, *American Woodworker Magazine*, *Woodworker's Journal*, *The Wood Post*, *String Instrument Craftsman*, *Guitarmaker*, *American Lutherie*, *Vintage*

Guitar Bulletin, *Reader's Digest Books*, and *Time-Life Books*. He is former Director of Research and Development for *Martin Guitar Company*, the former founding CEO of *Tacoma Guitar Co.* Additionally he has taught and lectured for a wide range of guilds, colleges and organizations including the *Smithsonian Institution*, *Anderson Ranch Arts Center*, *AWFS*, *Seattle Central College*, *Renton Technical College*, *American Institute of Organbuilders* and *The Architectural Woodworking Institute*, to name just a few.

He currently owns and operates *Rainy Day Ukes* (www.rainydayukes.com) a "green" company building ecologically friendly ukuleles exclusively from local woods, using benign materials and earth friendly construction methods, and regularly writes theatre reviews for the South Sound



President from page 1

The Jet 1015 lathe donated by Equipment Sales & Surplus has been mounted on a mobile stand and will be available for use that the May Sawdust Session.

Our club is looking for a new meeting place starting in 2017. We have very limited parking here. To help out with the parking issue many members need to carpool now.

I want to remind everyone that the mentors and others are available to help people with any questions or turning challenges throughout the month, not just at the meetings or Saw Dust Sessions. I am more than happy to work with anyone anytime, just give me a call to set up a time. The mentors also feel the same way, so you should not feel like you are putting anyone out. That is why we are here!

Be safe out there!

May Sawdust Session

Sawdust sessions are an opportunity for hands-on learning. Mentors are on hand to answer questions and provide assistance.

Topic: Burt Hovander's Homemade Chatter Tools

Details: Each attendee will make their own chatter tool from an old saw blade. Then we'll make tops and practice chatter techniques, as demonstrated by Burt. Attendance is limited and there will be a small materials fee. A sign-up sheet will be available at the meeting.

When: Saturday, May 14th

Where: AJ's Big Yellow Shop, 19304 Filbert Road, Bothell, WA 98012

Parking: Along the sides of the driveway or in front on the street
Do not park in the grass

Bring: Your turning tools, safety equipment, wood, a sack lunch

Additional Info:

- ◇ There is always wood available if you don't have a piece to turn.
- ◇ AJ is always happy to help sharpen tools and use his 14" band saw to cut wood for those that do not have the equipment.
- ◇ Beverages are provided but you are on your own for lunch.

Seattle Chapter, AAW 30th Anniversary

Mark February 9th, 2017 on your calendars. On this evening the club will celebrate it's 30th Anniversary. There will be many opportunities for members to participate in recognizing this special occasion.

The first opportunity is a 30th Anniversary Logo Contest. Details are still being worked out on the contest but get your creative juices flowing and help design a special logo. Who knows, it could be the logo the club adopts for the next 20 years until our 50th Anniversary.

Volunteers are needed to help with the planning and coordination of activities for February 9th. Most helpful would be a long time member of the club to help identify and contact former club officers. *Contact Dan Robbins de_robbsins@hotmail.com*

The Seattle Woodturners encourages it's members to join the AAW

The AAW has a rich library of content available to members. Content includes articles and videos on a variety of woodturning topics: Chucks, Sharpening, Shop Tips, and more. Members also have access to an archive of the American Woodturner (a bi-monthly printed publication) and Woodturning FUNdamentals (a bi-monthly digital publication aimed at foundational woodturning expertise).

For information about membership see the AAW's web site: <http://www.woodturner.org>



Volunteers

Every month we list the open volunteer positions in the newsletter. Some of the positions have been open for over 3 months. Now is the time to step forward and help us fill those open volunteer positions.

Outreach Coordinator, Inventory Control, Safety Officer,
Facilities Setup, Shop Tours, and Wood Raffle Coordinator

If you have the time, develop the inclination to participate in one of these activities. I have found that being involved in club activities has made me more of a turner. The activity of woodturning is generally a solitary activity. Being involved in club activities has brought me in contact with many people I might not have had the chance to get to know. Finally, some of these volunteer activities would be a great way for beginning turners to involve themselves in the club. The board will support every one of the volunteer activities.

Contact a board member for more information or to volunteer.



An Interesting Opportunity

Mike Hughes, who frequently has interesting things going, has something you may be interested in: a FREE OLD Craftsman lathe which you may turn into a treadle lathe. *Contact Mike [applepress64@gmail.com](mailto:mikeapplepress64@gmail.com)*



Seattle Mentors

Below are listed the current mentors for Seattle Woodturners. They want to help! They are excellent sources. If they can't answer a question, they will know how to find the answer.

Gary Clarke (segmented work)	<i>garyclarkewoodturner@hotmail.com</i>	(425) 451-3437
Les Dawson (beginning work)	<i>woodguy103@aol.com</i>	(425) 432-3879
Dan Johnson	<i>Dan1931@frontier.com</i>	(206) 412-7338
Hal Johnson	<i>1dognobird@comcast.net</i>	(425) 788-2221
David Lutrick	<i>Lutrick2@comcast.net</i>	(425) 557-9571
Jack McDaniel	<i>jack@aocb.com</i>	(425) 486-9205
AJ Mearns	<i>aj-17@juno.com</i>	(425) 501-0020
John Moe	<i>janjmoe@msn.com</i>	(425) 643-4522
Jose Pantoja	<i>josepantoja@forceonetech.com</i>	(206) 669-3270
Allan Rumpf (<i>beginning spindles</i>)	<i>lkmarginet@aol.com</i>	(206) 687-7128
Steve Sergev	<i>steve_sergev@yahoo.com</i>	(425) 868-5666
John Shrader	<i>shraderorder@hotmail.com</i>	(425) 653-3504
Bob Sievers (<i>off-center work</i>)	<i>woodchipper1@comcast.net</i>	(360) 897-8427
Vern Tator	<i>vernt47@gmail.com</i>	(206) 856 7659
Jack Wayne	<i>captjack327@yahoo.com</i>	(425) 488-9561

Seattle Outreach to Bellevue Art Museum

Once again we are going to support the Bellevue Art Museum KIDSFair, which runs at the same time as the BAM Arts Fair: July 29, 30, 31, 2016. KIDSFair is an opportunity for the club to interact with kids who visit the Museum during the fair and learn a little about woodturning.

In 2015 the club handed out over 600 tops for kids to decorate. The Outreach Committee has set a goal of 1000 tops for 2016.

Generous donations of wood have been prepped and provided to member to turn tops. If you picked up some of the wood you are encourage to turn in completed tops within 2 meetings. A container will be available at each meeting to drop off completed tops.

Let's get turning and hit our goal by the June Meeting!

Making a Top

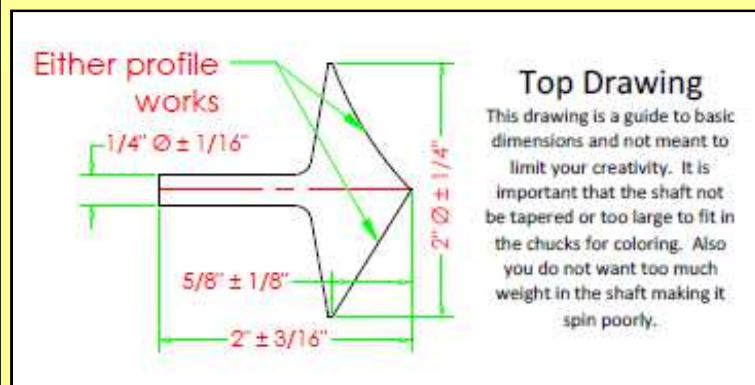

In general, tops should be around 2 inches tall with the stem being the longest part. The bottom should be about one third the total length. Usually the more weight on the bottom

the longer the top will spin. This may be something of a guide in turning yours. **One thing, though, make your handle straight so it will fit in our color wheel the kids use.** Of course use your own design.

Tops for KIDSfair

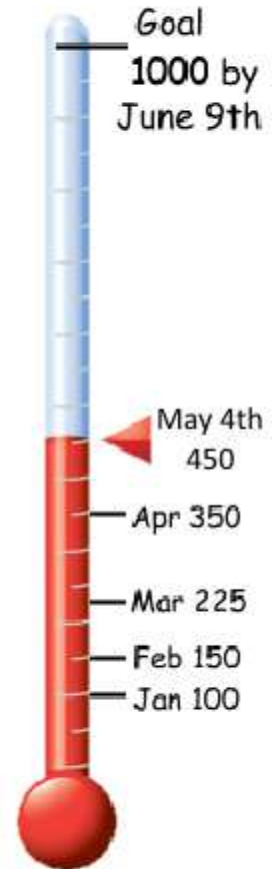

BAM ARTSfair
July 29-31



Beads of Courage Boxes Still Needed

So far we have about 10 Beads of Courage boxes turned in to Children's Hospital. They say they can use up to 30 a year, so your work is still needed!

These kids go through some painful tests and procedures. As they reach milestones they are given beads to recognize their progress that are placed in these boxes.

Boxes need to meet minimum size requirements:

6" diameter and 5" height

Simple Photo Tricks by David Reed Smith (December 2002)

Introduction

There have been several articles published lately on how you can take "almost" professional photographs of your turnings. This isn't that sort of article. If you need professional photographs because your living depends on getting into a prestigious gallery or craft show then you should actually hire a pro, not read another article.

But if you need photographs for your web site or to illustrate a magazine article you probably can't justify hiring a pro, but want something better than a flash picture with a point and shoot camera.

This article describes two easy and inexpensive ways to get photographs of turnings that are only a step or two down from professional.

Flatbed Scanner

To get an image of small articles that don't have a lot of height you can just plop them on a flatbed scanner and scan them. This technique is great for such things pens, refrigerator magnets, lace bobbins, or in my case, tatting accessories (see photo below.)

The lid of the scanner will usually lie at an angle so you'll get a nice graduated gray background. You may find you get better results by turning up the resolution (dpi) for your scan and then reducing the image size to the quality you need with software.

You can't control shadows, and you may get some reflections from the inside of the camera, but this is so easy you should try it first. It seems almost criminal to get images this effortlessly.



Two tatting accessories. This image was obtained by simply scanning with a Flatbed Scanner.

Dining Room Light Box

Bowls and vessels won't balance very well on a scanner, so unless you're unduly proud of the bottoms you'll need another technique for larger articles. I've had very good luck with my dining room light box.

It produces a seamless background and diffuse lighting, with just enough shadow to give definition. You don't need much equipment. You need a room with more or less neutral-colored walls that has a large window. White walls and a south-facing window would be ideal, but not essential. Most of the light comes from the window, not off the walls, so anything but hot purple would probably work. Besides a room, you need a camera, a tripod, a sheet of poster board, and something to prop the poster board up.

The photo below shows my setup to photograph a vessel. I've set it on the dining room table so I don't have to crouch. It faces the patio doors for plenty of indirect light. As it's somewhere near noon, I don't get harsh light direct from the sun. The vessel sits on the front of a sheet of poster board. The back edge is propped up with a two liter Pepsi bottle. As I'm not getting a placement fee, I must point out that Coke, juice, or any heavy article that's a foot high or so will work. Use poster board. Paper, even heavy white Kraft paper, will wrinkle instead of curving gently and may look mottled if backlit at all. The camera is mounted on a tripod to reduce motion. You can increase your odds of a sharp picture by using a cable release or timer.



Dining Room Light Box. An easy set-up to get photographs with a seamless background and diffuse light.



The photograph produced by the set-up above. This is a red oak vessel about 11 inches high and 9 inches in diameter.

WOODTURNERS OF OLYMPIA 2016 SYMPOSIUM FEATURING MICHAEL HOSALUK



SYMPOSIUM: Woodturners of Olympia 9th annual symposium featuring Michael Hosaluk with Bob Espen.

DATES: July 23, Workshops by Michael Hosaluk July 24 - 27

DESCRIPTION: The Woodturners of Olympia present their 9th annual symposium featuring world renowned Michael Hosaluk with Northwest turner Bob Espen.

Michael's demonstration will appeal to turners at all skill levels from beginner to advanced and will include, among other things, turning ladles, spatulas, bowls with enhancements, offset turning, spheres, the use of subtractive techniques to enhance your turnings, and thin turning green wood.

Michael Hosaluk is recognized internationally as one of the world's most creative wood "turners." Michael, who is an entertaining and engaging personality, is endorsed by everyone who has seen him demonstrate including three of the world recognized woodturners who provided quotes in support of our symposium:

Richard Raffan, states: *"... Michael has a formidable array of woodworking techniques to back his imagination and support his energy.....he's one of the very few turners I'm always happy to watch for hours at a time..."*

Bonnie Klein states: *"Mikey's quirky imagination and enthusiasm are extremely contagious. If I wasn't already a woodturner - I would just have to give it a try after being around him. I've been fortunate to have crossed paths with him many times over the past 25 years or so. He is an inspiration and a great demonstrator."*

And, Dale Larson notes that *"Michael is one of the best demonstrators and technical turners in North America."*

Cost is \$100 until June 1 and \$120 afterwards, which includes the all-day symposium, door prizes, lunch, and drawings for great prizes. Event starts 7 a.m. on July 23 at the Olympia High School, Olympia, Washington. The symposium is followed by 4 days of highly engaging workshops taught by Michael.

For more information or to register, go to the club's web site:

<http://www.woodturnersofolympia.org/symposium-2016.html>

Contact Information If you have moved, changed email addresses or have a new phone number update your information by sending an email seattleaawt@gmail.com

Membership Cards Available for pick up at the monthly Chapter meeting. If you cannot make it to the meeting, send a self-addressed stamped envelope to: Steve Gary, 17701 108th Ave SE, Unit 345, Renton, WA 98055.

Want Ads

For members to sell or purchase tools, wood, etc.
Get ads to Les Dawson by the 3rd Thursday of the month for the next newsletter.

For Sale: Bowl blanks and furniture wood. *Contact AJ Mearns (425) 501-0020 or aj-17@juno.com*

For Sale: Oneway 1640 Purchased 2007 from Craft Supplies. In excellent condition. Used by one person, Arnold Bowman. Also have woodturning tools compatible with this lathe. Also has a dust control attached which works well. *Contact Stacy Bowman (253) 589-1783*

For Sale: circa 1992 Powermatic table saw, long table on wheels, approx. 12-15 total hours, \$400 (obo). *Contact Dave (206) 290-3276*

For Sale: 10-in. Delta table saw on stand with rollers & table extensions. 2½-hp motor; \$150.00
Contact Wally Haugan (253) 631-5949 or hauganwj@msn.com

Sponsors

We encourage members to shop at club sponsors. They provide the gift certificates and donate equipment to the club. The following sponsors give a discount when you show your membership card: WoodCraft, Rockler, and Crosscut Hardwoods. CraftSuppliesUSA will give a 10% discount on abrasive if you identify yourself as a member of the Seattle Chapter, AAW.



AJ's Custom
Portable Saw Milling &
Wood Turning
Specializing in Custom Wood Products
AJ Mearns
425-775-7999 • Cell 425-501-0020
19304 Filbert Road • Bothell, WA 98012



Woodcraft Seattle features one of the largest inventories of turning tools & supplies in the NW. Club members get a 10% discount. Easy off and on I-5 at Exit 162 ("Corson/Michigan").
5963 Corson Ave S, Seattle 98108



Rockler has two location in the Seattle area. Club members get a 10% discount.
South Seattle - 345 Tukwila Parkway, Tukwila, WA 98188
North Seattle - 832 NE Northgate Way, Seattle WA 98125



The Woodworkers'
Candy Store ®

Crosscut Hardwoods is one of the largest domestic and exotic hardwood suppliers in the Seattle area catering to DIYer's and building professionals.
4100 First Ave S, Seattle WA 98134



Equipment Sales and Surplus provides "from the warehouse surplus" on JET, Powermatic, Wilton, Performax, and others as well as unmatched pricing on new items from these brands.
1801 West Valley Highway N, Auburn, WA 98001

Seattle Chapter Officers

President

A.J. Mearns aj-17@juno.com

Vice President

Jim Kief chabotkief@comcast.net

Secretary

Greg Raab greg.raab.73@gmail.com

Treasurer

Steve Gary seattleaawt@gmail.com

Director of Programs

Jim Steck

Director of Inventory Control

Mike Hughes

Director of Communications

Dan Robbins de_robbins@hotmail.com

Member-at-Large #1

Vern Tator vernt47@gmail.com

Member-at-Large #2

Corey Markus tahomabox@aol.com

Seattle Chapter Volunteers

Community Outreach

Mike Hughes applepress64@gmail.com
Jim Kief chabotkief@comcast.net

Videographers

Ryan Pederson ryan@pedersens.us
Bob Holzgraf rwholzgraf@gmail.com

Newsletter Editor

Les Dawson lescdawson@aol.com

Audio

Lawrence Brown gevarre@gmail.com

Web Site

Ryan Pederson ryan@pederson.us

Photographer

George McNeil gc.mcneil@me.com

Head Wood Rat

Vern Tator vernt47@gmail.com

Librarian

George Baskett

Sawdust Sessions

A.J. Mearns aj-17@juno.com

Trailer Puller

Jim Hogg jimhogg@microsoft.com

Hospitality

Jim Remington jwremington@gmail.com

Safety Officer

(open)

New Members and Mentors

George Hart

Sealer

Steve Sergev steve_sergev@yahoo.com

Inventory Control

(open)

Facilities Setup

(open)

The club is looking for volunteers. It is a great way to help build a stronger club. *Volunteers are needed for the following positions:*

Outreach Coordinator, Inventory Control, Safety Officer, and Facilities Setup, Shop Tours, and Wood Raffle Coordinator. Back-ups are also needed for all volunteer positions.

***Next Club Meeting: May 12, 2016
6:00 PM (social time) 6:30 (meeting time)***