



本處檔號 OUR REF. () in FP (LC) 314/07 V

來函檔號 YOUR REF.:

圖文傳真 FAX: 852-2367 3631

電話 TEL NO.: 852-2733 7744

電子郵件 E-MAIL: lcpolic2@hkfsd.gov.hk

17 August 2006

To: Recipients of FSD Circular Letters

Dear Sirs/Madams,

FSD Circular Letter No. 4/2006

**Guidelines on Specifications, Installation and
Maintenance of Fire Service Installations
and Equipment for the new fire safety requirements
of the New Territories Exempted Houses (hereinafter called Small Houses)**

This Circular Letter announces that the Department has drawn up three sets of guidelines on specifications, installation and maintenance of fire service installations and equipment for the new fire safety requirements for Small Houses applications.

Following a fire outbreak in Yue Wan Estate (a public housing estate) in 1995, the then Commissioner for Administrative Complaints (COMAC) conducted a comprehensive investigation into the provision of emergency vehicular access (EVA) and fire service installation (FSI) for public and private building developments. He recommended amongst others that EVA requirements should be imposed on Small Houses development. Since its inception in 1997, it has come to the Administration's attention that the provision of EVA appears to be impracticable, if not impossible, in some rural sites under application due to insurmountable constraints like site constraints, topographical constraints, land ownership constraints, etc.

...../P.2

Given various degrees of hardships faced by applicants, a working group comprising representatives from the Housing, Planning and Lands Bureau, Lands Department, Planning Department, Fire Services Department, Home Affairs Department and Heung Yee Kuk was set up in December 2005 to look into the EVA requirements, their implementation and problems encountered, and to explore alternatives.

Having critically examined alternative fire safety requirements that would be practicably applicable to Small Houses vis-à-vis the existing policy on fire safety in Small Houses development, it is decided that for Small Houses application sites located near a cluster of nine or more houses¹ the applicants should be requested, as the first step, to consider ways to provide an EVA to their application sites. If the applicant can satisfy the District Lands Office that the provision of an EVA is impracticable, he/she should implement one of the following fire safety alternatives:

- (i) automatic sprinkler system; or
- (ii) fire detection system and hose reel system – applicable if there is no fire separation between floors of the three-storey Small House; or
- (iii) fire detection system and fire extinguisher on each floor of the Small House – applicable if there is fire separation between floors of the three-storey Small House.

If the applicant opts for the fire safety alternative (ii) or (iii), he/she or his/her representative is required to attend a fire safety training course arranged by the Fire Services Department before applying for Certificate of Compliance.

The new arrangement has come into effect since 1 July 2006. A Guide to Fire Safety Requirements for Small Houses issued by the Lands Department is attached at **Appendix I** for reference.

For the purpose of assisting applicants in implementing the fire safety alternatives, the following three sets of guidelines on the specifications, installation and maintenance of the fire service installations have been formulated exclusively for Small Houses:

¹ Such house, should include existing houses, application sites under processing and approved sites, but exclude temporary and non-domestic structures.

...../P.3

- (i) Volume I - Automatic Sprinkler System
- (ii) Volume II - Fire Detection System and Hose Reel System
- (iii) Volume III - Fire Detection System and Extinguisher

One copy each of the guidelines is attached at **Appendix II** for your attention. You are advised to observe the application procedures set out in the guidelines in submitting drawings and the relevant Certificates of Fire Service Installations and Equipment (FS251). A flow chart showing the procedures for processing FSI drawings and inspection is also attached at **Appendix III** for reference.

Should you have any queries about the guidelines on and technical specifications of the above FSI, please contact the Planning Group at 2733 7819/2733 7758 and FSI Division of this Department at 2733 7563 respectively.

Yours faithfully,

(CHAN Chor-kam)
for Director of Fire Services

Encl.

New Territories Exempted Houses

A Guide to Fire Safety Requirements



Lands Department

1. Objectives of an Emergency Vehicular Access (EVA)

The provision of EVA is to ensure that in case of emergency, emergency vehicles including fire engines and ambulances have ready access to the village houses. This is essential for the protection of life and property.

2. Applicability of the EVA Requirements

A cluster of houses is defined as the houses within a circle with a radius of 30 metres measured from the centre of the proposed house site.

- (a) If the proposed house site is situated within a cluster of NINE houses¹ or less (including the proposed house site), the provision of EVA is not required.

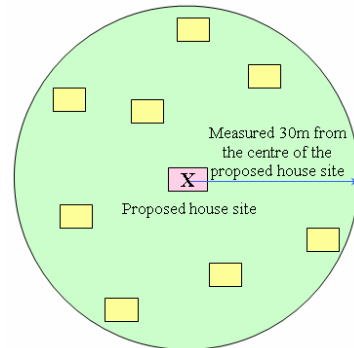

- (b) If the proposed house site is situated within a cluster of TEN houses¹ or more (including the proposed house site), the provision of EVA will be required.

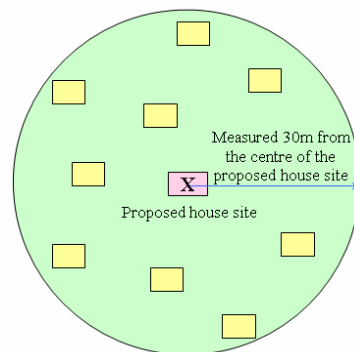

[¹ Only existing houses, proposed house sites under processing and approved house sites within a cluster will be counted. Temporary and non-domestic structures will be excluded. If more than 50% of a house is within the circle, the house is considered within the cluster.]

3. The Main EVA Requirements

Applications for New Territories Exempted Houses (NTEH) under scenario 2(b) will need to fulfill the following EVA requirements:-

- (a) there should be a vehicular access to allow emergency vehicles to reach within 30 metres from the NTEH;
- (b) such access, serving as an EVA, should be not less than 4.5 metres in width, or of a lesser width acceptable to Fire Services Department (FSD), with a headroom clearance of 4.5 metres and be capable of withstanding the loading of 16 tonne fire appliances; or headroom clearance and loading acceptable to FSD through a trial run; and
- (c) a standard pedestal type fire hydrant should be made available within 100m of the proposed house site.

4. Site Constraints in the Villages

If there are practical constraints rendering the provision of EVA impracticable, for instance if the village:

- (a) has no vehicular access because of topographical or land ownership constraints, and there is no prospect of having any kind of access; or
- (b) only has a sub-standard vehicular access and its improvement is hindered by site constraints,

the applicant should, having regard to the limitations of his proposed house site, apply to the District Lands Office to implement one of the fire safety alternatives below.

5. Fire Safety Alternatives

If the District Lands Office is satisfied that the provision of EVA is impracticable, the applicant should implement one of the following fire safety alternatives:-

- (i) automatic sprinkler system; or
- (ii) fire detection system and hose reel system – applicable if there is no fire separation between floors of the three-storey Small House; or
- (iii) fire detection system and fire extinguisher on each floor of the Small House – applicable if there is fire separation between floors of the three-storey Small House.

If the applicant opts for the fire safety alternative (ii) or (iii) above, he or his representative is required to attend a fire safety training course arranged by FSD before applying for Certificate of Compliance.

6. Enquiries

Enquiries on this pamphlet should be addressed to:

Village Improvement and Lease Enforcement/
Land Control Section,
Lands Department
22/F, North Point Government Offices,
333 Java Road, North Point
Hong Kong

Telephone Enquiries: 2231 3562

For general enquiries, please call

District Lands Office/Islands	2852 4265
District Lands Office/North	2675 1809
District Lands Office/Sai Kung	2791 7019
District Lands Office/Shau Tin	2158 4700
District Lands Office/Tai Po	2654 1263
District Lands Office/Tsuen Wan & Kwai Tsing	2402 1164
District Lands Office/Tuen Mun	2451 1176
District Lands Office/Yuen Long	2443 3573

June 2006 (Revised edition)



**New Territories
Exempted Houses
(Small Houses)**

**Automatic Sprinkler System
(Applicable to Small Houses)**

《Guidelines on Specifications, Installation and Maintenance
of Fire Service Installations and Equipment》

《Volume I》

Preamble

This set of guidelines is exclusively formulated for New Territories Exempted Houses (Small Houses) applicants. On account of topographical or land ownership constraints rendering the provision of EVA impracticable, such applicants, having obtained approval from District Lands Officer (DLO), are allowed to use an Automatic Sprinkler System in lieu of the Emergency Vehicular Access. The content of this set of guidelines is only applicable to domestic buildings of the New Territories Exempted Houses (Small Houses). The “Automatic Sprinkler System” is applicable to all New Territories Exempted Houses (Small Houses) used for domestic purpose.

Automatic Sprinkler System (Applicable to Small Houses)

<u>Introduction</u>	
1.	An automatic sprinkler system for a Small House is an improvised sprinkler system which mainly comprises sprinkler heads, sprinkler pipes, a set of sprinkler control valves, a sprinkler pump and a sprinkler tank.
2.	For the design and main components of an automatic sprinkler system, reference shall be made to the attached Schematic Drawing for Automatic Sprinkler System.
<u>Specifications and Installation</u>	<u>Sprinkler Heads</u>
3.	For the sprinkler head spacing/coverage, general reference shall be made to T.B. 14 of Loss Prevention Council Rules.
4.	Sprinkler coverage for toilets/bathrooms and balconies is not required.
5.	All sprinkler heads shall be of FSD approved type.
6.	Side-wall sprinklers are acceptable.
	<u>Sprinkler Pipes</u>
7.	For the sprinkler pipes and their sizes, reference shall be made to T.B. 14 of Loss Prevention Council Rules.
8.	UPVC sprinkler pipes of FSD approved type may be used.

	<u>Sprinkler Control Valves</u>
9.	A set of sprinkler control valve and pump panel which are properly covered shall be installed at an easily accessible location outside the domestic occupancy on ground floor.
10.	For the requirements of the set of sprinkler control valve, general reference shall be made to Loss Prevention Council Rules.
11.	The installation of a proving pipe is not required.
12.	The set of sprinkler control valve shall be properly secured and locked at the “Fully Open” position. Monitoring switches are not required.
13.	A sprinkler alarm gong shall be provided near the sprinkler control valve.
14.	No sprinkler inlet is required.
15.	Installation of alarm annunciation panel and connection of direct telephone link to the Fire Services Communications Centre are not required.
	<u>Sprinkler Pump</u>
16.	A pump shall be installed.
17.	No jockey pump is required.
18.	The pump shall be able to be manually actuated at the pump panel.
19.	A pressure sensing switch shall be provided for the automatic actuation and stopping of the pump.

20.	The sprinkler pump shall be electrically driven by a motor of not less than 2.2 kW.
21.	A pump panel shall be installed adjacent to the sprinkler pump.
22.	No sprinkler pump room is required, but the pump and its control panel should be properly covered. The effective operation of the system shall not be affected by the weather.
23.	No emergency generator is required but the power supply shall comply with the requirements as stipulated in FSD Circular Letter No. 4/96 Part IX. A secondary power source shall be provided in addition to the primary power source from the main switch box. The specification of fire resistant cables shall comply with T.B. 22.3.9.1 of Loss Prevention Council Rules.
	<u>Sprinkler Tank</u>
24.	A water tank shall be installed for the automatic sprinkler system. The effective capacity of the water tank shall not be less than 1,500L, 2,300L or 3,000L respectively, depending on the location of the site under application and the nearest location to which fire appliances are accessible. Suitable capacity shall be recommended by the FSD on a case by case basis.
25.	The location of the water tank will be subject to DLO's approval.
26.	If the water tank is located at roof, it can be combined with the flushing tank or potable water tank to form one water tank, but its volume shall comply with the requirements as stipulated in Buildings Ordinance (Application to the New Territories) Ordinance, Cap. 121, Laws of Hong Kong (i.e. 2m ² X 1.22m high with total volume not exceeding 2.44m ³). The water tank shall be internally partitioned to separate the water for F.S. purpose from other purposes in accordance with the requirements set by the Water Services Department (WSD). Such partition shall

	effectively prevent the contamination of potable water with the water for F.S. purpose.
27.	No water depth indicator is required.
28.	A non-ferrous non-return valve shall be provided between the downcoming main and the pump.
29.	The water tank shall be fed from a source of supply approved by the Water Authority and the Director of Fire Services.
30.	A Certificate of Completion for water for F.S. purposes issued by the WSD shall be obtained.
31.	Compliance with the specification as shown in the Loss Prevention Council Rules in respect of the structure and the materials for the water tank is not required. However, the WSD's requirements shall be met.

Note :

DLO's approval should be obtained if the facilities to be installed involve Government Land.

Maintenance

Owner of the above fire service installations and equipment is required to keep such facilities in effective working order at all times. The fire service installations and equipment shall be inspected by a registered Fire Service Installation (FSI) contractor (Class 2) at least once in every 12 months, and a Certificate of Fire Service Installations and Equipment (FS251) certifying the work done shall be issued.

Application procedures

1. A written submission enclosing a drawing of the automatic sprinkler system in triplicate shall be made by a registered FSI contractor (Class 2) or consultant to the Planning Group of FSD, certifying that the details and specifications on the drawing are in compliance with the requirements of the FSD and that the design is in accordance with the relevant rules and codes.
2. Upon completion of works on the required fire service installations and equipment by the registered FSI Contractor (Class 2), the applicant is required to submit a copy of Certificate FS251 certifying the work done to the Planning Group of FSD.
3. Prior to the issuance of a Certificate of Compliance for the Small House, an inspection will be carried out by the FSD to ascertain that the design and installation of such fire service installations and equipment comply with the relevant rules and codes.

Remarks

Matters concerning the installation of an automatic sprinkler system shall be dealt with by a registered FSI contractor (Class 2).

Installation charges shall be agreed between Small House applicants and their registered FSI contractor. Such charges should cover all installations, tests and the submission of Certificate FS251 to the FSD. The responsible registered FSI contractor should also take part and render assistance to the FSD in the inspection(s) of fire service installations and equipment prior to occupation.

For information on registered FSI contractors, you may make enquiry to any fire station or browse our website at

http://www.hkfsd.gov.hk/home/eng/source/class_2_en.pdf

for the “FSI Contractors” column under the “Information Release”.

If you have any enquiry about this set of guidelines, please contact the Planning Group of FSD:

Planning Group / Fire Services Department

9/F, Fire Services Headquarters Building,

No. 1 Hong Chong Road,

Tsim Sha Tsui East,

Kowloon.













Fax No: 2367 6976 or 2739 8775

You may also contact the following offices for enquiry:

<u>Area</u>	<u>Telephone</u>
Lantau Island and Islands	2733 7736 / 2733 7738
Sai Kung, Tseung Kwan O, Shatin, Eastern and Northern New Territories	2733 7735 / 2733 7739
Tsuen Wan, Tuen Mun, Tin Shui Wai, Yuen Long, Western and Northern New Territories	2733 7737 / 2733 7758

Schematic Drawing for Automatic Sprinkler System

Legend

-  Gate Valve
-  Non-return Valve
-  Y-Strainer
-  Pressure Switch Assembly
-  Pressure Gauge
-  Flexible Connector
-  Sprinkler Control Valve Set
-  Air Vent
-  Pump Panel
-  Sprinkler Pump
-  Sprinkler Head
-  Ball Valve
-  Sprinkler Alarm Bell

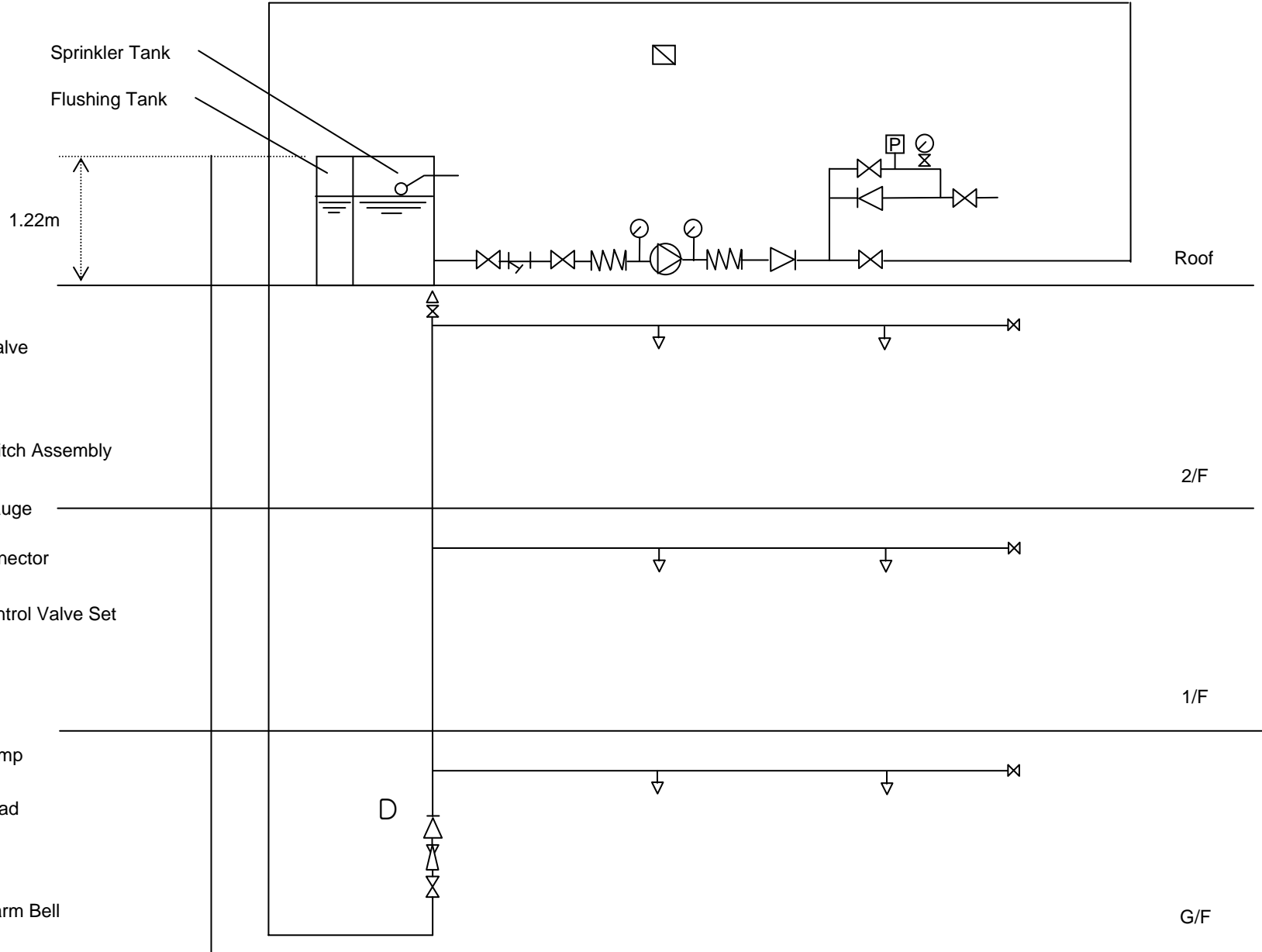



**New Territories
Exempted Houses
(Small Houses)**

**Fire Detection System and
Hose Reel System
(Applicable to Small Houses)**

《Guidelines on Specifications, Installation and
Maintenance of Fire Service Installations and Equipment》

《Volume II》

Preamble

This set of guidelines is exclusively formulated for New Territories Exempted Houses (Small Houses) applicants. On account of topographical or land ownership constraints rendering the provision of EVA impracticable, such applicants, having obtained approval from District Lands Officer (DLO), are allowed to use a Fire Detection System and a Hose Reel System in lieu of the Emergency Vehicular Access. The content of this set of guidelines is only applicable to the domestic buildings of the New Territories Exempted Houses (Small Houses). The “Fire Detection System and the Hose Reel System” are applicable to all New Territories Exempted Houses (Small Houses) which are used for domestic purpose and have no fire separation between floors.

Fire Detection System (Applicable to Small Houses)

<u>Introduction</u>	
1.	A fire detection system for a Small House mainly comprises detectors and electric wires connecting the detectors and alternating current (AC) supply.
<u>Specifications and Installation</u>	<u>Smoke Detector</u>
2.	Detectors shall be of FSD approved type.
3.	An independent fire detection system shall be installed on each floor or in each unit.
4.	The detectors of each system shall be powered by AC supply.
5.	Each detector shall be connected to a back-up battery.
6.	Detectors shall be installed independently in all rooms and living rooms, except kitchens, bathrooms, balconies and staircases, etc.
7.	Detectors shall be installed on the ceiling.
8.	When the doors of all rooms are shut and if any one of the detectors is actuated, a sound volume of not less than 60 decibels (A) shall be measured in all rooms or living rooms on the same floor.
9.	Installation of alarm annunciation panel and connection of direct telephone line to Fire Services Communications Centre are not required.

Hose Reel System (Applicable to Small Houses)

<u>Introduction</u>	
1.	A hose reel system for a Small House mainly comprises a water tank, a pump, a fire alarm bell, a manual fire alarm call point and a hose reel.
2.	For the design and main components of a hose reel system for a Small House, reference shall be made to the attached Schematic Drawing for Hose Reel System.
<u>Specifications and Installation</u>	<u>Water Tank</u>
3.	A water tank shall be installed for the hose reel system. The effective capacity of the fire services water tank shall not be less than 1,000L or 1,500L, depending on the location of the site under application and the nearest location to which fire appliances are accessible. Suitable capacity shall be recommended by the FSD on a case by case basis.
4.	The location of the water tank will be subject to DLO's approval.
5.	If the water tank is located at roof, it can be combined with the flushing tank or potable water tank to form one water tank if the tank is located at roof, but its volume shall comply with the requirements as stipulated in Buildings Ordinance (Application to the New Territories) Ordinance, Cap. 121, Laws of Hong Kong (i.e. 2m ² X 1.22m high with total volume not exceeding 2.44m ³). The water tank shall be internally partitioned to separate the water for F.S. purpose from other purposes in accordance with the requirements set by the Water Services Department (WSD). Such partition shall effectively prevent the contamination of potable water with the water for F.S. purpose.

6.	A non-ferrous non-return valve shall be provided between the downcoming main and the pump.
7.	The water tank shall be fed from a source of supply approved by the Water Authority and the Director of Fire Services.
8.	Compliance with the specification as shown in the Loss Prevention Council Rules in respect of the structure and the materials for the water tank is not required. However, the WSD's requirements shall be met.
9.	A Certificate of Completion issued by the WSD shall be obtained.
10.	No water depth indicator is required.
	<u>Pump</u>
11.	A pump shall be installed. Once started, the pump must run continuously until stopped manually at the pump control panel installed near the pump.
12.	No emergency generator is required but the power supply shall comply with the requirements as stipulated in FSD Circular Letter No. 4/1996 Part IX. A secondary power source shall be provided in addition to the primary power source from the main switch box. The specification of fire resistant cables shall comply with the requirements as stipulated in FSD Circular Letter No. 1/2003.
13.	The pump shall be electrically driven by a motor of not less than 3kW.
14.	A pump control panel shall be installed adjacent to the pump.
15.	No F.S. pump room is required, but the pump and its control panel should be properly covered. The effective operation of the system shall not be affected by the weather.

	<u>Hose Reel</u>
16.	Manual fire alarm call point(s) used for the actuation of the pump and the fire alarm bell(s) shall be positioned at prominent and accessible location near the hose reel(s) at a level of not more than 1,200mm above finished floor level.
17.	The design of the hose reel shall be such that the tubing is permanently connected, via pipes in the drum of the hose reel and such stuffing box(es) as may be necessary, to the supply main.
18.	The internal bore of the hose reel tubing shall be not less than 19mm, such tubing shall have a bursting pressure of not less than 2,700 kPa and shall not be porous nor exhibit any sign of percolation under pressure up to 2,000 kPa.
19.	The tubing of every hose reel shall not exceed 30 metres in length. When fitted with hose reel nozzle, the tubing shall be capable of projecting a jet not less than 6 metres in length.
20.	The hose reel nozzle shall have a 4.5 mm orifice and be fitted with a simple two-way valve to open or shut off the jet. The valve shall not be spring-loaded.
21.	Rising main and associated pipework used for the hose reels shall be not less than 40 mm nominal bore and pipes feeding individual hose reel shall not be less than 25 mm nominal bore.
22.	A hose reel shall be so installed that its control valve and nozzle, which should be situated adjacent to each other, are at a position above and not more than 1,350 mm from the finished floor level. The hose reel nozzle should be housed in a glass-fronted cabinet secured under lock and key. Furthermore, a metal or plastic striker about 300 mm long, should be provided besides the cabinet.
23.	The hose reel can be installed on walls of the staircase enclosure on G/F or at a prominent position within the staircase soffit.

24.	For the requirements of the lettering and the operation instruction notice of fire hose reel, reference can be made to paragraph 5.14 of the latest edition of the Code of Practice for Minimum Fire Service Installations and Equipment.
25.	No F.S. Inlet is required.
	<u>Water Pipes</u>
26.	UPVC water pipes of FSD approved type may be used.

Note :

DLO's approval should be obtained if the facilities to be installed involve Government Land.

Maintenance

Owner of the above fire service installations and equipment is required to keep such facilities in effective working order at all times. The fire service installations and equipment shall be inspected by a registered Fire Service Installations (FSI) contractor at least once in every 12 months, and a Certificate of Fire Service Installations and Equipment (FS251) certifying the work done shall be issued.

Application procedures

1. A written submission enclosing the drawings of the fire detection system and hose reel system in triplicate shall be made by a registered FSI contractor or consultant to the Planning Group of FSD, certifying that the details and specifications on the drawing are in compliance with the requirements of the FSD and that the design is in accordance with the relevant rules and codes.
2. Upon completion of works on the required fire service installations and equipment by the registered FSI Contractor, the applicant is required to submit a copy of Certificate FS251 certifying the work done to the Planning Group of FSD.
3. Prior to the issuance of a Certificate of Compliance for the Small House, an inspection will be carried out by the FSD to ascertain that the design and installation of such fire service installations and equipment comply with the relevant rules and codes.

Remarks

Matters concerning the installation of fire detection system shall be dealt with by a registered FSI contractor (Class 1), while matters concerning the installation of hose reel system shall be dealt with by a registered FSI contractor (Class 2).

Installation charges shall be agreed between Small House applicants and their registered FSI contractor. Such charges should cover all installations, tests and the submission of Certificate FS251 to the FSD. The responsible registered FSI contractor should also take part and render assistance to the FSD in the inspection(s) of fire service installations and equipment prior to occupation.

For information on registered FSI Contractors, you may make enquiry to all fire stations or browse for our website at

http://www.hkfsd.gov.hk/home/eng/source/class_1_en.pdf ; and

http://www.hkfsd.gov.hk/home/eng/source/class_2_en.pdf

for the “FSI Contractors” column under the “Information Release”.

If you have any enquiry about this set of guidelines, please contact the Planning Group of FSD:

Planning Group / Fire Services Department

9/F, Fire Services Headquarters Building,

No. 1 Hong Chong Road,

Tsim Sha Tsui East,

Kowloon.













Fax No: 2367 6976 or 2739 8775

You may also contact the following offices for enquiry:

<u>Area</u>	<u>Telephone</u>
Lantau Island and Islands	2733 7736 / 2733 7738
Sai Kung, Tseung Kwan O, Shatin, Eastern and Northern New Territories	2733 7735 / 2733 7739
Tsuen Wan, Tuen Mun, Tin Shui Wai, Yuen Long, Western and Northern New Territories	2733 7737 / 2733 7758

Schematic Drawing for Hose Reel System

Legend

	Gate Valve		Flexible Connector
	Non-return Valve		Air Vent
	Y-Strainer		Hose Reel Pump
	Pressure Gauge		Hose Reel
	Ball Valve		Nozzle
	Pump Panel		Manual Fire Alarm Call Point
	Fire Alarm Bell		

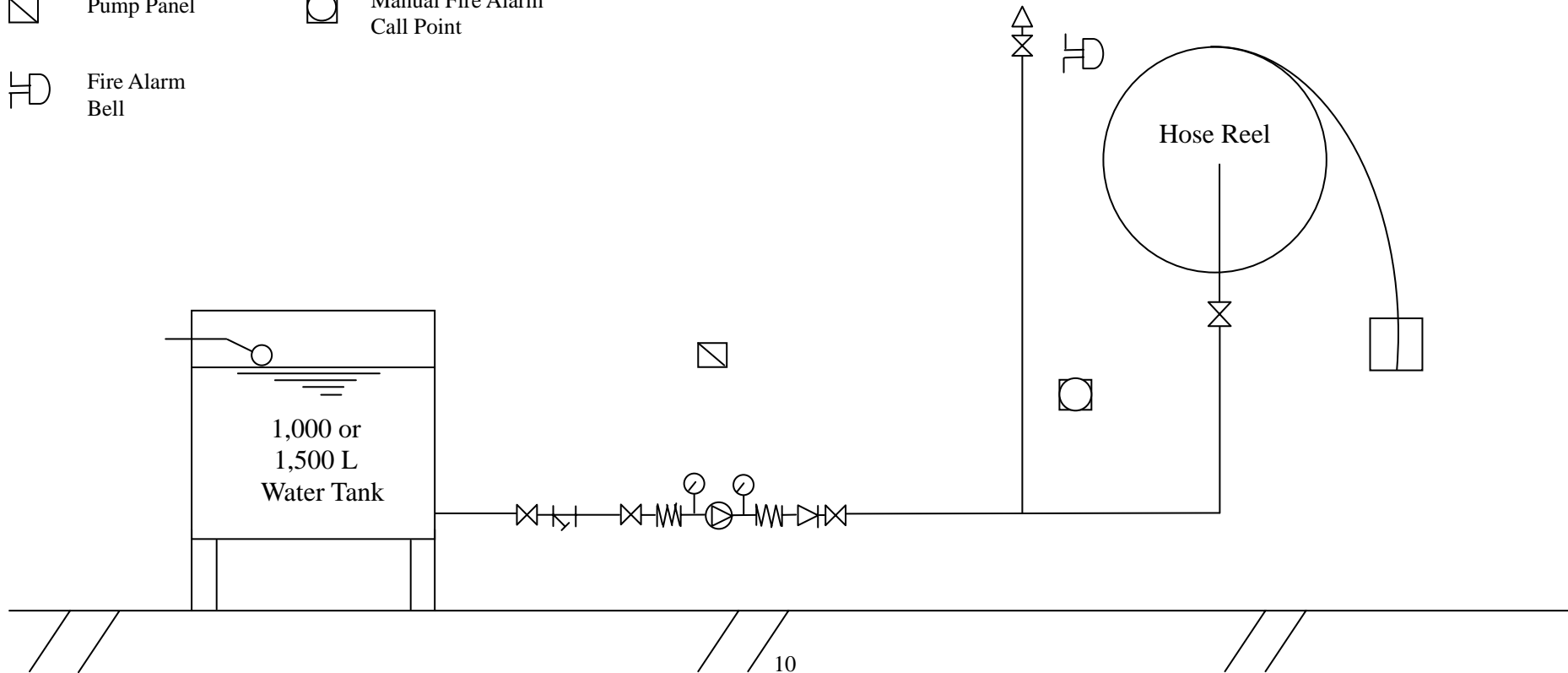



**New Territories
Exempted Houses
(Small Houses)**

**Fire Detection System and
Fire Extinguisher
(Applicable to Small Houses)**

《 Guidelines on Specifications, Installation and
Maintenance of Fire Service Installations and Equipment 》

《 Volume III 》

Preamble

This set of guidelines is exclusively formulated for New Territories Exempted Houses (Small Houses) applicants. On account of topographical or land ownership constraints rendering the provision of EVA impracticable, such applicants, having obtained approval from District Lands Officer (DLO), are allowed to use a Fire Detection System and Fire Extinguishers in lieu of the Emergency Vehicular Access. The content of this set of guidelines is only applicable to domestic buildings of the New Territories Exempted Houses (Small Houses). The “Fire Detection System and Fire Extinguishers” are applicable to all New Territories Exempted Houses (Small Houses) which are used for domestic purpose and have fire separation between floors.

Fire Detection System (Applicable to Small Houses)

<u>Introduction</u>	
1.	A fire detection system for a Small House mainly comprises detectors and electrical wires connecting the detectors and alternating current (AC) supply.
<u>Specifications and Installation</u>	<u>Smoke Detectors</u>
2.	Detectors shall be of FSD approved type.
3.	An independent fire detection system shall be installed on each floor or in each unit.
4.	The detectors of each system shall be powered by AC supply.
5.	Each detector shall be connected to a back-up battery.
6.	Detectors shall be installed in all rooms and living rooms, except kitchens, bathrooms, balconies and staircases, etc.
7.	Detectors shall be installed on the ceiling.
8.	When the doors of all rooms are shut and if any one of the detectors is actuated, a sound volume of not less than 60 decibels (A) shall be measured in all rooms or living rooms on the same floor.
9.	Installation of alarm annunciation panel and connection of direct telephone line to Fire Services Communications Centre are not required.

Fire Extinguisher (Applicable to Small Houses)

<u>Introduction</u>	
1.	The fire extinguishers used in a Small House must be of dry powder type and at least 4 kg in weight.
<u>Specifications and Installation</u>	<u>Fire Extinguisher</u>
2.	A fire extinguisher shall be installed on each floor of a Small House.
3.	Fire extinguishers shall be of FSD approved type.
4.	The applicant can commission a registered Fire Service Installation (FSI) contractor to install fire extinguishers, or install by himself / herself on a need basis. However, the applicant is required to produce the Certificate of Fire Service Installations and Equipment (FS251) issued by a registered FSI contractor to prove that the fire extinguishers are in good condition.

Maintenance

1. Owner of the above fire service installations and equipment is required to keep the facilities in effective working order at all times. The fire service installations and equipment shall be inspected by a registered FSI contractor at least once in every 12 months, and a Certificate FS251 certifying the work done shall be issued.
2. A hydraulic pressure test on the cylinder should be conducted every five years in accordance with the manufacturers' instructions.
3. Prior to disposal of the fire extinguisher, the dry powder in the cylinder should be discharged to an enclosure for re-cycling or disposal. For details, please refer to Fire Protection Notice No. 11.

Application procedures

1. A written submission enclosing a drawing of the Fire Extinguisher (if applicable) and a drawing of the fire detection system in triplicate shall be made by a registered FSI contractor or consultant to the Planning Group of FSD, certifying that the details and specifications on the drawings are in compliance with the requirements of the FSD and that the design is in accordance with the relevant rules and codes.
2. Upon completion of works on the required fire service installations and equipment by the registered FSI Contractor, the applicant is required to submit a copy of Certificate FS251 certifying the work done to the Planning Group of FSD.
3. Prior to the issuance of a Certificate of Compliance for the Small House, an inspection will be carried out by the FSD to ascertain that the design and installation of such fire service installations and equipment comply with the relevant rules and codes.

Remarks

Matters concerning the installation of a fire detection system shall be dealt with by a registered FSI contractor (Class 1), while matters concerning fire extinguishers shall be dealt with by a registered FSI contractor (Class 3).

Installation charges shall be agreed between Small House applicants and their registered FSI contractor. Such charges should cover all installations, tests and the submission of Certificate FS251 to the FSD. The responsible registered FSI contractor should also take part and render assistance to the FSD in the inspection(s) of fire service installations and equipment prior to occupation.

For information on registered FSI Contractors, you may make enquiry to any fire stations or browse our website at

http://www.hkfsd.gov.hk/home/eng/source/class_2_en.pdf ; and

http://www.hkfsd.gov.hk/home/eng/source/class_3_en.pdf

for the “FSI Contractors” column under the “Information Release”.

If you have any enquiry about this set of guidelines, please contact the Planning Group of FSD:

Planning Group / Fire Services Department
9/F, Fire Services Headquarters Building,
No. 1 Hong Chong Road,
Tsim Sha Tsui East,
Kowloon.

Fax No: 2367 6976 or 2739 8775

You may also contact the following offices for enquiry:

<u>Area</u>	<u>Telephone</u>
Lantau Island and Islands	2733 7736 / 2733 7738
Sai Kung, Tseung Kwan O, Shatin, Eastern and Northern New Territories	2733 7735 / 2733 7739
Tsuen Wan, Tuen Mun, Tin Shui Wai, Yuen Long, Western and Northern New Territories	2733 7737 / 2733 7758

FSD Procedures for processing fire service installation (FSI) drawings and inspection in respect of the New Territories Exempted House Applications Adopting the Fire Safety Alternatives (as at 1.7.2006)

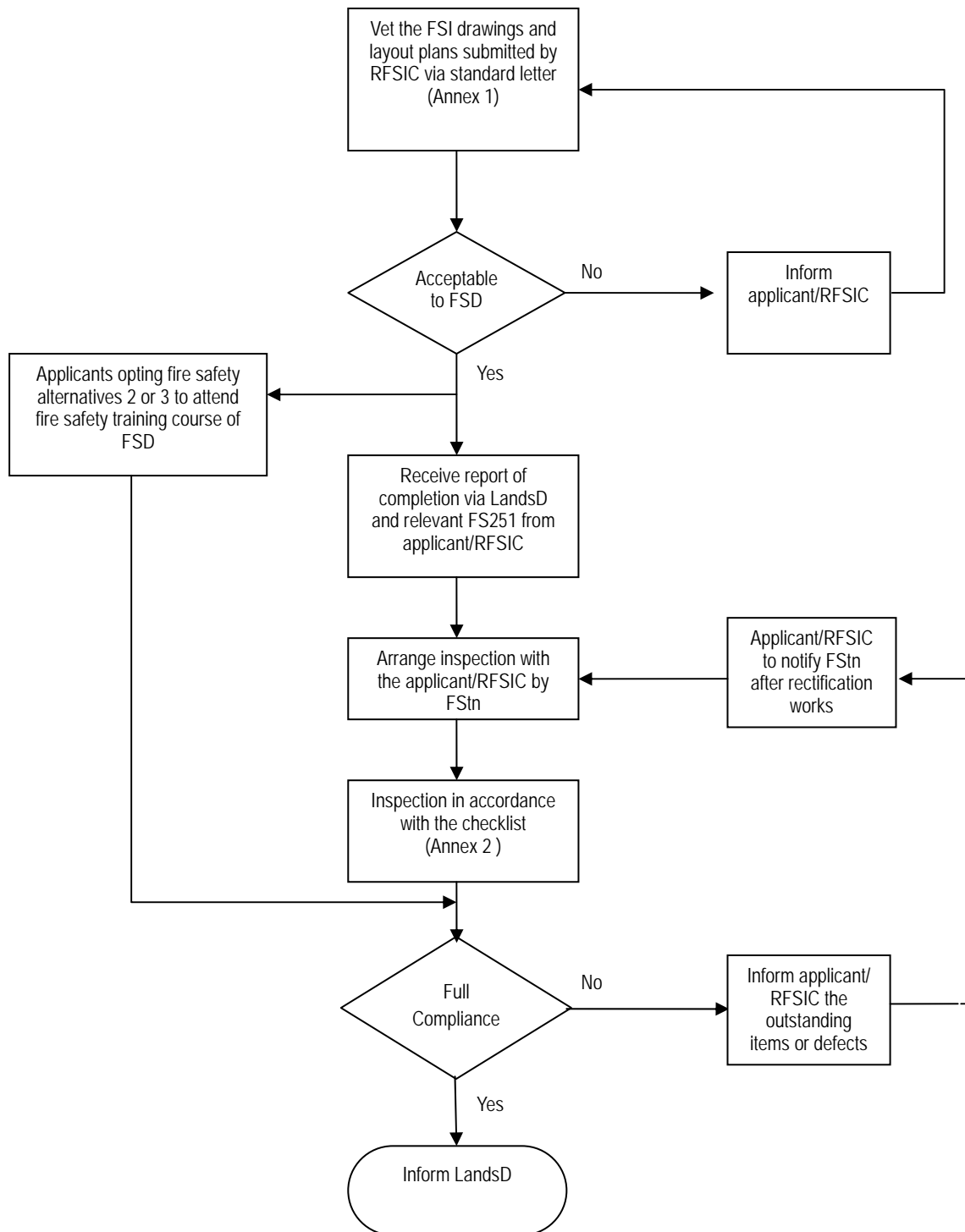

Abbreviation

- FSD - Fire Services Department
- LandsD - Lands Department
- FStn - Fire Station
- RFSIC - Registered Fire Service Installation Contractor
- FS251 - Certificate of Fire Service Installation and Equipment

To: Director of Fire Services
Attn: Planning Group,
9/F, Fire Services Headquarters Building,
1 Hong Chong Road, Tsim Sha Tsui East,
Kowloon, Hong Kong.

Your file reference : FSD/PG/.....

Fire Service Installation *Schematic Drawings / Layout Drawings for
New Territories Exempted House (NTEH) at

(Address)
.....

This is to certify that the details and specifications of all installations and equipment shown on the attached fire service installation drawings (in triplicate) of the above NTEH are as prescribed by the Fire Services Department and in accordance with the relevant guidelines as listed below:-

- Guidelines Vol. 1 for Specifications, Installation and Maintenance of Automatic Sprinkler System (Applicable to Small Houses) for NTEH

- Guidelines Vol. 2 for Specifications, Installation and Maintenance of Fire Detection System and Fire Hose Reel System (Applicable to Small Houses) for NTEH

- Guidelines Vol. 3 for Specifications, Installation and Maintenance of Fire Detection System (Applicable to Small Houses) and Fire Extinguisher for NTEH

Signed..... Date.....

Full Name of FSI Contractor/Consultant.....

Correspondence Address.....

..... Tel. No. :.....

- Mark "x" where applicable
- * Delete where appropriate

**Checklist for Automatic Sprinkler System
(Applicable to Small Houses)**

File No. :	FS 251 No. :
Date :	Inspection Officer :
Address :	
Name of owner / Responsible Person(R/P), if present :	
Name of Fire Service Installation Contractor(FSIC), if present :	
FSIC No. :	

A. General		
1. Floors protected _____		
B. Sprinkler Main Valve Group		
1. Location of Main Valve Group _____		
2. Is Main Stop Valve in open position?	<input type="checkbox"/> Yes	<input type="checkbox"/> No
3. Is Alarm Gong Valve in open position?	<input type="checkbox"/> Yes	<input type="checkbox"/> No
4. Is Test Valve in closed position?	<input type="checkbox"/> Yes	<input type="checkbox"/> No
5. Is Alarm Gong Test Valve in closed position?	<input type="checkbox"/> Yes	<input type="checkbox"/> No
6. Pressure readings* _____ (gauge B) _____ (gauge C)		
C. Pump		
1. Location of Sprinkler Pump _____		
2. Are the primary and Secondary power supplies normal?	<input type="checkbox"/> Yes	<input type="checkbox"/> No
3. Are indication lamps normal?	<input type="checkbox"/> Yes	<input type="checkbox"/> No
4. Are gate valves in normal positions?	<input type="checkbox"/> Yes	<input type="checkbox"/> No
5. Does the sprinkler pump operate satisfactorily after the drain valve/test valve is opened?	<input type="checkbox"/> Yes	<input type="checkbox"/> No
D. Sprinkler Tank		
1. Location of Sprinkler Tank and capacity _____		
2. Is water level normal?	<input type="checkbox"/> Yes	<input type="checkbox"/> No
E. FS 251		
Is the content of FS 251 correct?	<input type="checkbox"/> Yes	<input type="checkbox"/> No
F. Remarks (if any)		
G. Reinstatement of Operational mode		
Has the system been reinstated into normal operational mode?	<input type="checkbox"/> Yes	<input type="checkbox"/> No
No, the reason is		
Is follow-up action required?	<input type="checkbox"/> Yes	<input type="checkbox"/> No

*('B' - Pressure gauge fitted immediately below main alarm stop valve;
'C' - Pressure gauge fitted immediately above main alarm stop valve.)

Test witnessed by:-

.....(Signature)(Signature)
.....(Name in block letters)(Name in block letters)
F.S.I. Contractor's Representative	F.S.D. Inspecting Officer
Date.....	Date.....

Explanatory notes for checklist compilation

Automatic Sprinkler System

(Applicable to Small Houses)

File No./Date/Address/FS 251 No./Inspection Officers (I/O) are self-explanatory. In respect of Name of Owner/Responsible Person (R/P), the capacity of R/P should be specified if not owner (such as occupier/consultant, etc.).

A. General

1. Floors protected refers to those floors where sprinklers are installed.

B. Sprinkler Main Valve Group

1. The location of the main valve group refers to the floor on which the valve group is installed.
2. }
3. } For lever type gate valve, the valve is in open position when lever is in line with the pipe.
4. } For screw type gate valve, the valve is in open position when the valve is turned in anti-clockwise direction.
5. }
6. Record the reading of the gauges.

_____ The positions of gauge B and gauge C are shown in attached diagram (Fig. 1).

C. Pump

1. The location of the sprinkler pump refers to the floor on which the pump is installed.
2. } Check the status of the relevant indicator lamps according to the
3. } legend/miniatures/notes as illustrated on the indication panel.
4. Gate valves are normally in open positions.
5. Test the sprinkler pump in accordance with the following procedures :-
 - i) Open the drain valve/test valve to induce a flow and thereby actuating the sprinkler pump (ensure water discharge not causing nuisance/damage to 3rd party property). Observe the change in the readings of 'B' & 'C' gauges.
 - ii) When the sprinkler pump is running, the alarm gong will sound simultaneously.
 - iii) Close the drain valve/test valve and the system pressure will increase gradually indicated by the rise of reading of 'C' gauge.
 - iv) When the system pressure reaches the designed level, the sprinkler pump will stop automatically.

D. Sprinkler Tank

1. The location of the sprinkler tank refers to the floor on which the tank is installed.
2. Water level should be close to the overflow pipe.

E. FS 251

Self-explanatory.

F. Remarks (if any)

Any other information, defects or action taken by the I/O should be provided (e.g. referral to FSITF for follow-up action etc.)

G. Reinstatement of Operational mode

Self-explanatory.

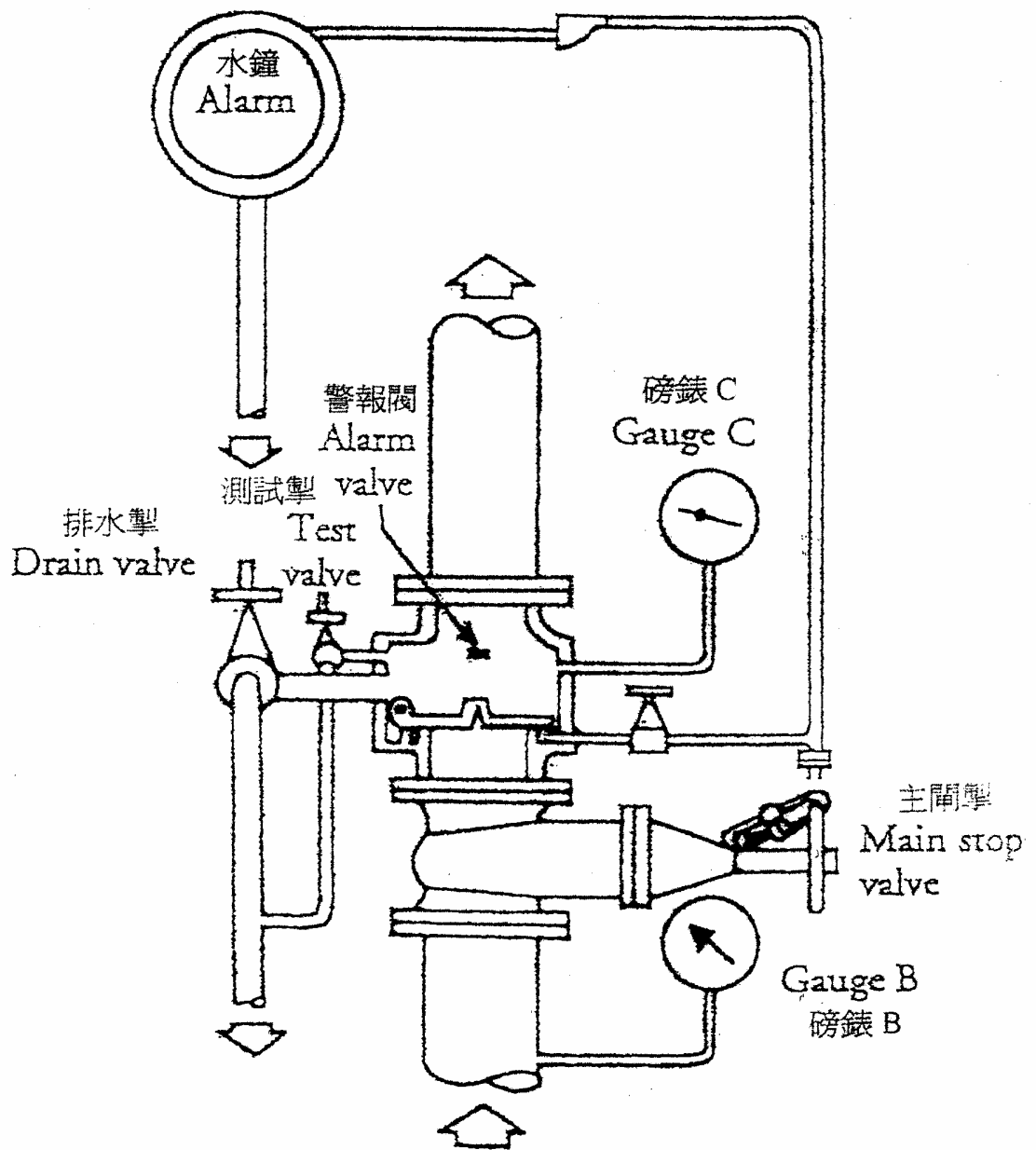

Fig. 1 Position of gauge B and gauge C
 圖 1 (磅錶 B 及磅錶 C 的位置)

**Checklist for Fire Detection System
(Applicable to Small Houses)**

File No. :	FS 251 No. :
Date :	Inspection Officer :
Address :	
Name of owner / Responsible Person(R/P), if present :	
Name of Fire Service Installation Contractor(FSIC), if present :	
FSIC No. :	

A. General		
1. Areas protected _____		
B. Power Supply		
1. Are the detectors of each system with alternating current supply?	<input type="checkbox"/> Yes	<input type="checkbox"/> No
2. Has each detector connected to a back-up battery?	<input type="checkbox"/> Yes	<input type="checkbox"/> No
C. Locations of Detector		
1. Are all rooms and living room except kitchen, bathroom, balcony and staircase provided with independent detector?	<input type="checkbox"/> Yes	<input type="checkbox"/> No
2. Are the detectors installed on ceiling?	<input type="checkbox"/> Yes	<input type="checkbox"/> No
D. FS 251		
Is the content of FS 251 correct?	<input type="checkbox"/> Yes	<input type="checkbox"/> No
E. Remarks (if any)		
F. Reinstatement of Operational mode		
Has the system been reinstated into normal operational mode?	<input type="checkbox"/> Yes	<input type="checkbox"/> No
No, the reason is		
Is follow-up action required?	<input type="checkbox"/> Yes	<input type="checkbox"/> No

Test witnessed by:-

.....(Signature)(Signature)
.....(Name in block letters)(Name in block letters)
F.S.I. Contractor's Representative	F.S.D. Inspecting Officer
Date.....	Date.....

Explanatory notes for checklist compilation

Fire Detection System

(Applicable to Small Houses)

File No./Date/Address/FS 251 No./Inspection Officers (I/O) are self-explanatory. In respect of Name of Owner/Responsible Person (R/P), the capacity of R/P should be specified if not owner (such as occupier/consultant etc.).

A. General

1. Areas protected refers to the rooms and floors at which the detectors are installed.

B. Power Supply

1. The power supply to the detectors of each system shall be alternating current.
2. Each detector shall be connected to a back-up battery.

C. Location of Detector

1. Each room and living room shall be provided with an independent detector except kitchen, bathroom, balcony and staircase soffit.
2. The detector shall be installed on ceiling.

D. FS 251

Self-explanatory.

E. Remarks (if any)

Any other information, defects or action taken by the I/O should be provided (e.g. referral to FSITF for follow-up action etc.)

F. Reinstatement of Operational mode

Self-explanatory.

**Checklist for Fire Hose Reel System
(Applicable to Small Houses)**

File No. :	FS 251 No. :
Date :	Inspection Officer :
Address :	
Name of owner / Responsible Person(R/P), if present :	
Name of Fire Service Installation Contractor(FSIC), if present :	
FSIC No. :	

A. General		
1. Floors protected _____		
2. Is Fire Alarm System provided?	<input type="checkbox"/> Yes	<input type="checkbox"/> No
B. Pump		
1. Location of Pump _____		
2. Are the primary and secondary power supplies normal?	<input type="checkbox"/> Yes	<input type="checkbox"/> No
3. Are indication lamps normal?	<input type="checkbox"/> Yes	<input type="checkbox"/> No
4. Are gate valves in normal positions?	<input type="checkbox"/> Yes	<input type="checkbox"/> No
5. Do all other items function properly (w/o fault signal)?	<input type="checkbox"/> Yes	<input type="checkbox"/> No
C. Alarm Bell/Call Point		
1. Are the following items in order/without irregularity:-		
i. electric wiring/connection?	<input type="checkbox"/> Yes	<input type="checkbox"/> No
ii. alarm bell?	<input type="checkbox"/> Yes	<input type="checkbox"/> No
iii. call point?	<input type="checkbox"/> Yes	<input type="checkbox"/> No
2. Is the sound of alarm bell audible in vicinity?	<input type="checkbox"/> Yes	<input type="checkbox"/> No
D. Hose Reel		
1. Provided?	<input type="checkbox"/> Yes	<input type="checkbox"/> No
2. Do the hose reel nozzle exist?	<input type="checkbox"/> Yes	<input type="checkbox"/> No
3. Is gate valve in effective working order?	<input type="checkbox"/> Yes	<input type="checkbox"/> No
4. Is hose reel drum turning freely?	<input type="checkbox"/> Yes	<input type="checkbox"/> No
5. Without leakage of water?	<input type="checkbox"/> Yes	<input type="checkbox"/> No
6. Is it capable of projecting a 6-metre jet	<input type="checkbox"/> Yes	<input type="checkbox"/> No
E. FS Tank		
1. Location of FS Tank and capacity _____		
2. Is water level normal?	<input type="checkbox"/> Yes	<input type="checkbox"/> No
F. FS 251		
Is the content of FS 251 correct?	<input type="checkbox"/> Yes	<input type="checkbox"/> No
G. Remarks (if any)		
H. Reinstatement of Operational mode		
Has the system been reinstated into normal operational mode?	<input type="checkbox"/> Yes	<input type="checkbox"/> No
No, the reason is		
Is follow-up action required?	<input type="checkbox"/> Yes	<input type="checkbox"/> No

Test witnessed by:-

.....(Signature)(Signature)
.....(Name in block letters) F.S.I. Contractor's Representative Date.....(Name in block letters) F.S.D. Inspecting Officer Date.....

Explanatory notes for checklist compilation

Fire Hose Reel System

(Applicable to Small Houses)

File No./Date/Address/FS 251 No./Inspection Officers (I/O) are self-explanatory. In respect of Name of Owner/Responsible Person (R/P), the capacity of R/P should be specified if not owner (such as occupier/consultant etc.).

A. General

1. Check the hose reel point.
2. Self-explanatory.

B. Pump

1. Self-explanatory, if in doubt, enquire the R/P at scene.
2. } Check the status of respective indication lamps according to
3. } legend/miniatures/notes as illustrated on the panel.
4. The gate valve should be in open position.
5. Check the status of respective indication lamps according to legend/miniatures/notes as illustrated on the panel.

C. Alarm Bell/Call Point

1. Self-explanatory.
2. Check whether the sound of alarm bell is audible in the vicinity.

D. Hose Reel

1. }
2. } Self-explanatory.
3. Physically turn the gate valve to check if it can be operated freely.
4. Physically pull out the hose reel to check if it can be operated freely.
5. }
6. } Self-explanatory.

E. FS Tank

1. Self-explanatory, if in doubt, enquire the R/P at scene.
2. Water level should be close to the overflow pipe.

F. FS 251

Self-explanatory.

G. Remarks (if any)

Any other information, defects or action taken by the I/O should be provided (e.g. referral to FSITF for follow-up action etc.)

H. Reinstatement of Operational mode

Self-explanatory.