

INSTALLATION MANUAL

FULL-CASED MULTI-POSITION FOR COOLING/HEAT PUMPS
MODELS: MC

FULL-CASED UPFLOW/COUNTERFLOW FOR COOLING/HEAT PUMPS
MODELS: FC

PARTIAL-CASED UPFLOW FOR COOLING/HEAT PUMP
MODELS: PC



LIST OF SECTIONS

SAFETY	1	CONDENSATE DRAIN CONNECTIONS	6
GENERAL INFORMATION	2	REFRIGERANT LINE CONNECTION	7
COIL METERING DEVICES	4	COIL CLEANING	7
COIL INSTALLATION	4	AIR SYSTEM ADJUSTMENT	7
DUCT CONNECTIONS	6	INSTALLATION VERIFICATION	8

LIST OF FIGURES

Component Location - Coil MC & FC	2	Upflow Coil Installation	6
Component Location - Coil PC	2	Condensate Deflector on Vertical Drain Pan	6
TXV Bulb Installation	4	Condensate Deflector on Horizontal Drain Pan Edge	7
Proper Bulb Location	4	S-Clip Installation	7
Vertical Applications	4	Pressure Check	8
Coil Flange	5	TXV Check List	8
Horizontal Right Application	5	Drain Traps	8
Horizontal Left Application	5	Location of Trapped and Plugged Drain Connections	8

LIST OF TABLES

Dimensions - MC Coils	2	Entering Air Temperature Limits	4
Dimensions - FC Coils	3	Coil Projection Dimensions - PC Coils	6
Dimensions - PC Coils	3	Air Flow Data - Static Pressure Drop	7
Coil Air Flow Limits	4		

SECTION I: SAFETY



This is a safety alert symbol. When you see this symbol on labels or in manuals, be alert to the potential for personal injury.

Understand and pay particular attention to the signal words **DANGER**, **WARNING**, or **CAUTION**.

DANGER indicates an **imminently hazardous** situation, which, if not avoided, **will result in death or serious injury**.

WARNING indicates a **potentially hazardous** situation, which, if not avoided, **could result in death or serious injury**.

CAUTION indicated a **potentially hazardous** situation, which, if not avoided may result in minor or moderate injury. It is also used to alert against unsafe practices and hazards involving only property damage.

WARNING

Improper installation may create a condition where the operation of the product could cause personal injury or property damage. Improper installation, adjustment, alteration, service or maintenance can cause injury or property damage. Refer to this manual for assistance or additional information, consult a qualified installer or service agency.

CAUTION

This product must be installed in strict compliance with the enclosed installation instructions and any applicable local, state, and national codes including, but not limited to building, electrical, and mechanical codes.

WARNING

The furnace area must not be used as a broom closet or for any other storage purposes, as a fire hazard may be created. Never store items such as the following on, near or in contact with the furnace.

1. Spray or aerosol cans, rags, brooms, dust mops, vacuum cleaners or other cleaning tools.
2. Soap powders, bleaches, waxes or other Cleaning compounds; plastic items or containers; gasoline, kerosene, cigarette lighter fluid, dry cleaning fluids or other volatile fluid.
3. Paint thinners and other painting compounds.
4. Paper bags, boxes or other paper products

Never operate the furnace with the blower door removed. To do so could result in serious personal injury and/or equipment damage.

SECTION II: GENERAL INFORMATION

This instruction covers the installation of the following coils with 80+ or 90+ AFUE furnaces or MA/MV air moving systems.

The coils have sweat connect fittings. All coils are shipped with a low psi nitrogen holding charge.

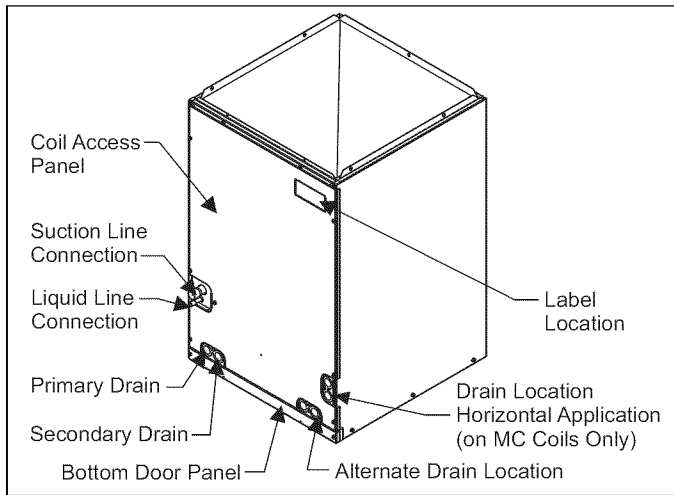

FIGURE 1: Component Location - Coil MC & FC

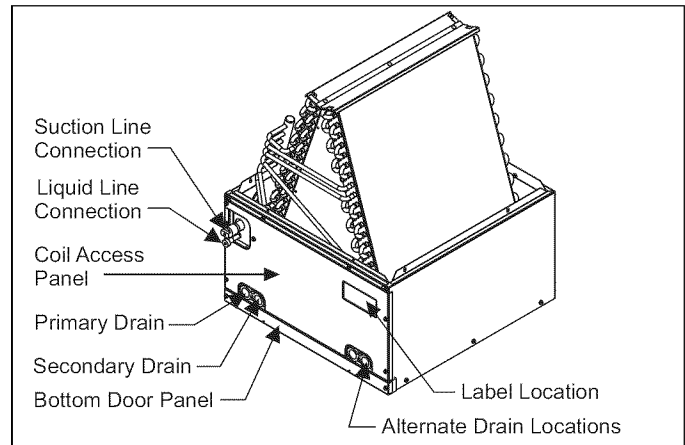

FIGURE 2: Component Location - Coil PC

INSPECTION

As soon as a coil is received, it should be inspected for possible damage during transit. If damage is evident, the extent of the damage should be noted on the carrier's delivery receipt. A separate request for inspection by the carrier's agent should be made in writing. See Local Distributor for more information. Check drain pan for cracks or breakage.

CLEARANCES

DURING INSTALLATION

Clearance must be provided for:

1. Refrigerant piping and connections
2. Maintenance and servicing access - including cleaning the coil
3. Condensate drain line
4. Filter removal / change
5. Removal of coil assembly

TABLE 1: Dimensions - MC Coils

Model	A	B	C	D	Refrigerant Line Size ¹	
					Liquid	Vapor
18A	14.5	22	13 3/8	13.5	3/8	3/4
18B	17.5	22	16 3/8	16.5	3/8	3/4
24A	14.5	26.5	13 3/8	13.5	3/8	3/4
24B	17.5	26.5	16 3/8	16.5	3/8	3/4
30A	14.5	26.5	13 3/8	13.5	3/8	3/4
30B	17.5	26.5	16 3/8	16.5	3/8	3/4
32A	14.5	22	13 3/8	13.5	3/8	3/4
35B	17.5	22	16 3/8	16.5	3/8	3/4
35C	21	22	19 7/8	20	3/8	3/4
36A	14.5	26.5	13 3/8	13.5	3/8	7/8
36B	17.5	26.5	16 3/8	16.5	3/8	7/8
36C	21	26.5	19 7/8	20	3/8	7/8
37A	14.5	26.5	13 3/8	13.5	3/8	3/4
42B	17.5	32	16 3/8	16.5	3/8	7/8
42C	21	32	19 7/8	20	3/8	7/8
43B	17.5	26.5	16 3/8	16.5	3/8	7/8
43C	21	26.5	19 7/8	20	3/8	7/8
48C	21	32	19 7/8	20	3/8	7/8
48D	24.5	32	23 3/8	23.5	3/8	7/8
60D	24.5	32	23 3/8	23.5	3/8	7/8
62D	24.5	36	23 3/8	23.5	3/8	7/8

All MC coils include a factory installed horizontal drain pan.
(3X) = Models require field installed metering device.

1. Refrigerant line sizes may require larger lines for extended line lengths. See York bulletin #690.01-AD1V for details.

TABLE 2: Dimensions - FC Coils

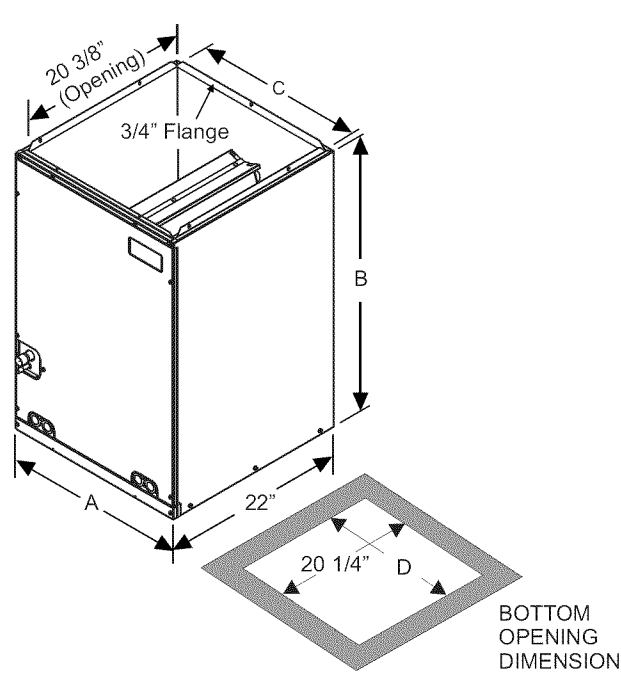

Model	A	B	C	D	Refrigerant Line Size ¹	
					Liquid	Vapor
18A	14.5	18	13 3/8	13.5	3/8	3/4
18B	17.5	18	16 3/8	16.5	3/8	3/4
24A	14.5	22	13 3/8	13.5	3/8	3/4
24B	17.5	22	16 3/8	16.5	3/8	3/4
30A	14.5	22	13 3/8	13.5	3/8	3/4
30B	17.5	22	16 3/8	16.5	3/8	3/4
32A	14.5	20	13 3/8	13.5	3/8	3/4
35B	17.5	20	16 3/8	16.5	3/8	3/4
35C	21	20	19 7/8	20	3/8	3/4
36A	14.5	24.5	13 3/8	13.5	3/8	7/8
36B	17.5	24.5	16 3/8	16.5	3/8	7/8
36C	21	24.5	19 7/8	20	3/8	7/8
37A	14.5	24.5	13 3/8	13.5	3/8	3/4
42B	17.5	28	16 3/8	16.5	3/8	7/8
42C	21	28	19 7/8	20	3/8	7/8
43B	17.5	24.5	16 3/8	16.5	3/8	7/8
43C	21	24.5	19 7/8	20	3/8	7/8
48C	21	28	19 7/8	20	3/8	7/8
48D	24.5	28	23 3/8	23.5	3/8	7/8
60C	21	28	19 7/8	20	3/8	7/8
60D	24.5	28	23 3/8	23.5	3/8	7/8
62D	24.5	32	23 3/8	23.5	3/8	7/8
64D	24.5	36	23 3/8	23.5	3/8	7/8

20 3/8" (Opening)
3/4" Flange
A
B
C
D
22"
20 1/4"
BOTTOM OPENING DIMENSIONS

All FC coils are not available with a factory installed horizontal drain pan.
(3X) = Models require field installed metering device.

1. Refrigerant line sizes may require larger lines for extended line lengths. See York bulletin #690.01-AD1V for details.

TABLE 3: Dimensions - PC Coils

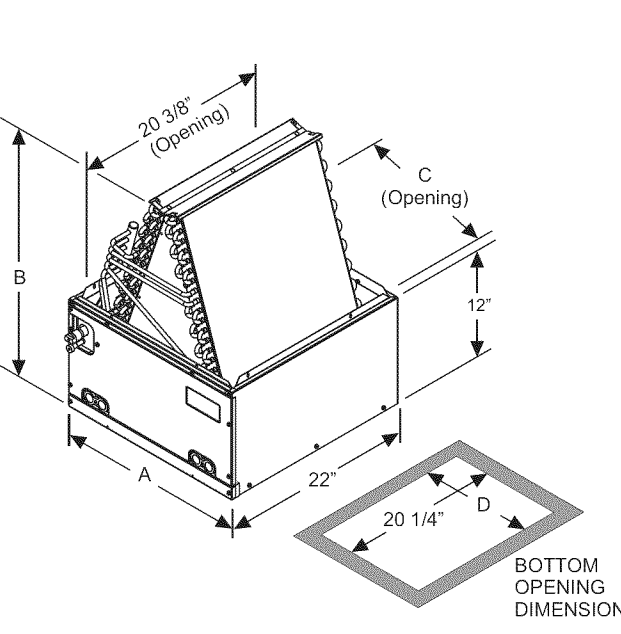

Model	A	B	C	D	Refrigerant Line Size ¹	
					Liquid	Vapor
18A	14.5	17 3/4	13 3/8	13.5	3/8	3/4
18B	17.5	17	16 3/8	16.5	3/8	3/4
24A	14.5	21 7/8	13 3/8	13.5	3/8	3/4
24B	17.5	21 3/8	16 3/8	16.5	3/8	3/4
30A	14.5	21 7/8	13 3/8	13.5	3/8	3/4
30B	17.5	21 3/8	16 3/8	16.5	3/8	3/4
32A	14.5	20	13 3/8	13.5	3/8	3/4
35B	17.5	18 7/8	16 3/8	16.5	3/8	3/4
35C	21	18 3/4	19 7/8	20	3/8	3/4
36A	14.5	23 7/8	13 3/8	13.5	3/8	7/8
36B	17.5	23 1/8	16 3/8	16.5	3/8	7/8
36C	21	22 7/8	19 7/8	20	3/8	7/8
37A	14.5	23 7/8	13 3/8	13.5	3/8	3/4
42B	17.5	27 5/8	16 3/8	16.5	3/8	7/8
42C	21	27 1/8	19 7/8	20	3/8	7/8
43B	17.5	23 1/8	16 3/8	16.5	3/8	7/8
43C	21	22 5/8	19 7/8	20	3/8	7/8
48C	21	25 3/8	19 7/8	20	3/8	7/8
48D	24.5	24 5/8	23 3/8	23.5	3/8	7/8
60C	21	27 1/2	19 7/8	20	3/8	7/8
60D	24.5	26 7/8	23 3/8	23.5	3/8	7/8

20 3/8" (Opening)
B
C (Opening)
12"
A
D
22"
20 1/4"
BOTTOM OPENING DIMENSIONS

All PC coils are not available with a factory installed horizontal drain pan.
(3X) = Models require field installed metering device.

1. Refrigerant line sizes may require larger lines for extended line lengths. See York bulletin #690.01-AD1V for details.

LIMITATIONS

These coils should be installed in accordance with all national and local safety codes. Check Tables 4 and 5 for operating limitations.

TABLE 4: Coil Air Flow Limits

Coil Size	Outdoor Unit Tons	CFM Limits	
		Minimum	Maximum
18	1-1/2	525	675
24	1-1/2	525	675
	2	700	900
30, 32	2	700	900
	2-1/2	875	1125
35	2-1/2	875	1125
	3	1050	1200
36, 37	2-1/2	875	1125
	3	1050	1350
42	3	1050	1350
	3-1/2	1225	1575
43	3	1050	1350
	3-1/2	1225	1575
48	3	1050	1350
	3-1/2	1225	1575
	4	1400	1800
60, 62, 64	4	1600	1800
	5	1750	2250

TABLE 5: Entering Air Temperature Limits

WET BULB TEMP. (°F)		DRY BULB TEMP. (°F)	
MIN.	MAX.	MIN.	MAX.
57	72	65	95

SECTION III: COIL METERING DEVICES

If the model number is of the following format: ****4F***, ****4G***, ****4H***, ****4J***, or ****4K*** - The coil will have an R410A TXV metering device installed at the factory.

If the model number is of the following model series:

****3X*** - The coil will require a TXV to be installed in the field. Refer to installation manual with TXV kit. It is recommended to install the TXV kit prior to installation of coil in cabinet and brazing line sets.

Models matched with orifices:

Alternate ****3X***, consult the outdoor installation guide for outdoor units that require an orifice as a metering device for the indoor coil. The orifice and the Schraeder core are supplied with the outdoor unit. Install Schraeder core in the suction line Schraeder body and cap with the supplied plastic cap.

TXV METERING DEVICE

Please refer to Technical Guide to verify which TXV is installed in this coil and that this is a valid system match for the AC or HP unit installed. The temperature sensing bulb is attached to the coil suction header line.

NOTE: For models that have factory installed TXV's, take caution not to apply high temperatures to the TXV assembly or equalizer line while brazing.

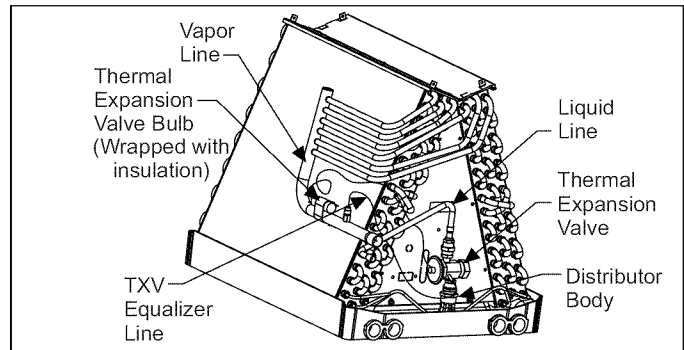

FIGURE 3: TXV Bulb Installation

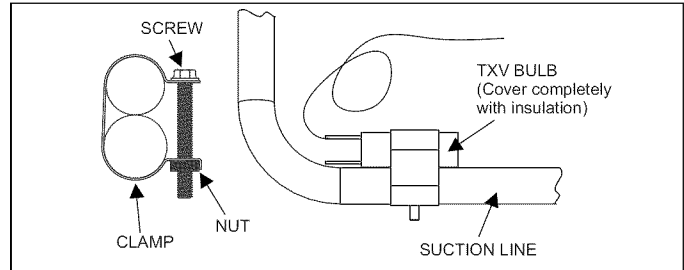

FIGURE 4: Proper Bulb Location

CAUTION

COIL UNDER PRESSURE.

Relieve pressure by removing plug from piping connection. Coil may have factory installed TXV or may require TXV to be added. See outdoor unit documentation for correct TXV to be used. Refer to coil nameplate for TXV identification for this unit.

NOTE: The coil should be open to the air for no more than 2 minutes to keep moisture and contaminants from entering the system. If the coil cannot be brazed into the refrigeration system in that time, the ends should be temporarily closed or plugged. For a short term delay, use masking tape over the ends of the copper tubing to close the tube to the air. For a longer term delay, use plugs or caps. There is no need to purge the coil if this procedure is followed.

SECTION IV: COIL INSTALLATION

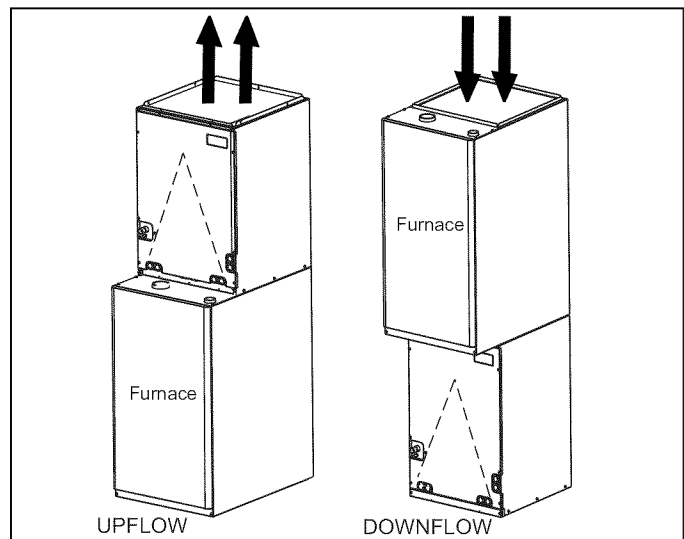

FIGURE 5: Vertical Applications

FURNACE ASSEMBLY - MC & FC

These coils are factory shipped for installation in either upflow or downflow applications with no conversion.

1. Position the coil casing over or under the furnace opening as shown in Figure 8 after configuring coil flanges as required see "Coil Flange" section below and refer to Figure 9.
2. Place the ductwork over the coil casing flange and secure. See sections on "Refrigerant Line Connections" and "Condensate Drain Connections". One mounting plate is provided with the coils.

NOTE: When installing this coil with an oil furnace, a minimum of six inches clearance should be maintained from the top of the heat exchanger.

COIL FLANGE - FOR DOWNFLOW AND HORIZONTAL LEFT KIT INSTALLATION

The coils include removable flanges to allow proper fit up with furnaces or two-piece air handlers having various inlet and outlet flange configurations. The two flanges are attached to the top of the coil in the factory during production. If the installation requires the flanges to be moved to the bottom of the coil, remove the screws attaching the flanges to the top of the coil casing. Next, install the flanges to the bottom of the coil casing using the same screws. Refer to Figure 9.

The additional holes in the upper area of the flanges may be used to attach the coil to the furnace or two-piece air handler. This is done by installing field-supplied screws through the flanges into the inside of the furnace or two-piece air handler casing.

The front flange is also designed so that it can be rotated 180 degrees and re-installed. In this mounting configuration the front flange will extend further to the front of the coil casing to accommodate furnaces or two-piece air handlers that have a greater front-to-back dimension than the coils.

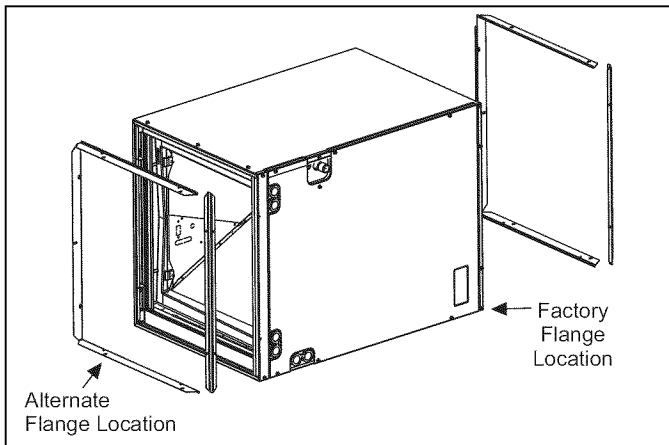

FIGURE 6: Coil Flange

FURNACE ASSEMBLY - (MC ONLY)

MC coils are supplied ready to be installed in a horizontal position. A horizontal pan is factory installed. MC coils should be installed in all horizontal applications with the horizontal drain pan side down.

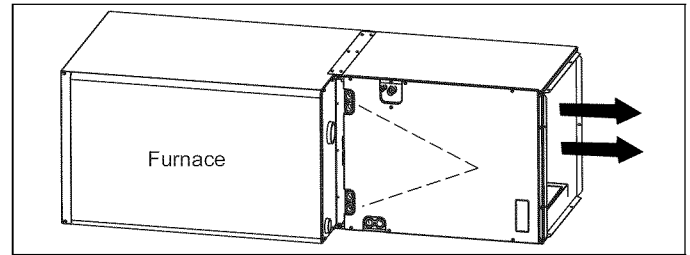

FIGURE 7: Horizontal Right Application

For horizontal left hand applications no conversion is required to an MC coil when used with a downflow/horizontal furnace. A mounting plate, supplied with every coil should always be installed on the side designated as top side. See Figure 10 & 11.

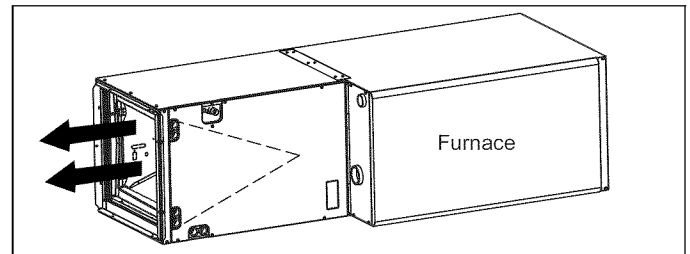

FIGURE 8: Horizontal Left Application

FURNACE ASSEMBLY - PC

These upflow coils are designed for installation on top of upflow furnaces only.

If the coil is used with a furnace of a different size, use a 45° transition to allow proper air distribution through the coil.

1. Position the coil casing over the furnace opening as shown in Figure 12.
2. Place the ductwork over the coil casing flange and secure.
3. Check for air leakage between the furnace and coil casing and seal appropriately.

CAUTION

Do not drill any holes or drive any screws into the front duct flange on the coil in order to prevent damaging coil tubing (see Figure 12).

NOTE: When installing this coil with an oil furnace, a minimum of six inches clearance should be maintained from the top of the heat exchanger.

NOTE: Refer to the heat pump add-on control instruction before installing an add-on heat pump coil.

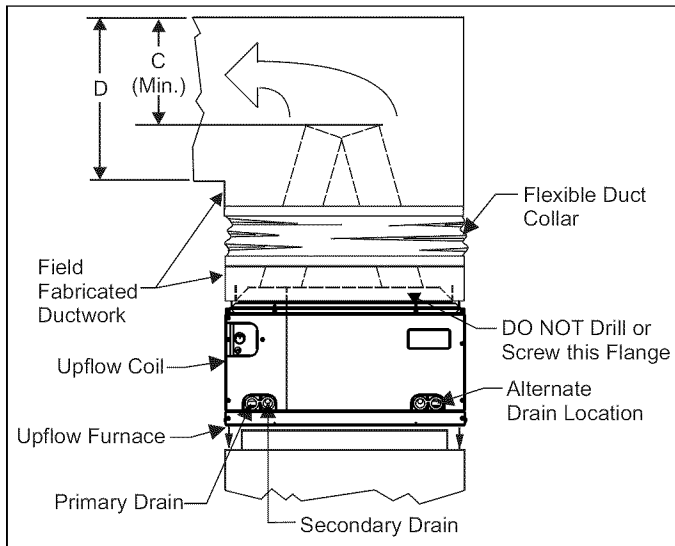

FIGURE 9: Upflow Coil Installation

TABLE 6: Coil Projection Dimensions - PC Coils

COIL SIZE	DIMENSION "C" INCH
PC18	3-1/2
PC24	4-1/2
PC30, PC32, PC35	4-1/2
PC42, PC43, PC36, PC37	5-1/2
PC48	6-1/2
PC60	9

NOTE: Dimension "C" should be at least 2/3 of dimension "D". See Figure 12.

CRITICAL COIL PROJECTION

The coil assembly must be located in the duct such that a minimum distance is maintained between the top of the coil and the top of the duct. Refer to Table 6.

SECTION V: DUCT CONNECTIONS

Air supply and return may be handled in one of several ways best suited to the installation. Upflow, horizontal or downflow applications may be used.

The vast majority of problems encountered with combination heating and cooling systems can be linked to improperly designed or installed duct systems. It is therefore highly important to the success of an installation that the duct system be properly designed and installed.

Use flexible duct collars to minimize the transmission of vibration/noise into the conditioned space.

WARNING

Use 1/2" screws to connect ductwork to unit. If pilot holes are drilled, drill only through field duct and unit flange.

Where return air duct is short, or where sound may be a problem, sound absorbing glass fiber should be used inside the duct. Insulation of duct work is a must where it runs through an unheated space during the heating season or through an uncooled space during the cooling season. The use of a vapor barrier is recommended to prevent absorption of moisture from the surrounding air into the insulation. The supply air duct should be properly sized by use of a transition to match unit opening. All ducts should be suspended using flexible hangers and never fastened directly to the structure. Duct work should be fabricated

and installed in accordance with local and/or national codes. This includes the standards of the National Fire Protection Association for Installation of Air-Conditioning and Ventilating Systems, NFPA No. 90B.

CAUTION

Equipment should never be operated without filters.

SECTION VI: CONDENSATE DRAIN CONNECTIONS

All drain lines should be pitched away from unit drain pan and should be no smaller than the coil drain connection.

Route the drain line so that it doesn't interfere with accessibility to the coil, furnace, air handling system or filter and will not be exposed to freezing temperatures.

Instruct the owner that the evaporator coil drain pan should be inspected and cleaned regularly to prevent odors and assure proper drainage.

NOTE: When the coil is installed in an attic or above a finished ceiling, an auxiliary drain pan must be provided under the coil as is specified by most local building codes.

Coils should be installed level or pitched slightly toward the drain end. Suggested pitch should not exceed 1/4-inch per foot of coil.

If the coil is provided with a secondary drain it should be piped to a location that will give the occupant a visual warning that the primary drain is clogged. If the secondary drain is not used it must be capped.

CAUTION

Avoid Double Trapping.

CAUTION

Threaded drain connections should be hand tightened, plus no more than 1 turn.

DO NOT use Teflon™ tape, "pipe dope", or other sealants. The use of a sealant may cause damage and premature failure of the drain pan.

NOTE: If the coil is installed in a draw-thru application (modular air handler), it is recommended to trap the primary and secondary drain line. If the secondary drain line is not used, it must be capped.

SUCTION FEEDER TUBECONDENSATE DEFLECTOR

Upflow or Downflow

No action required. See Figure 13.

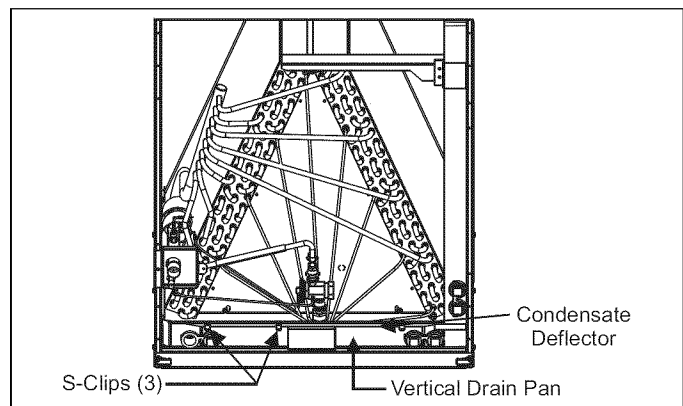

FIGURE 10: Condensate Deflector on Vertical Drain Pan

Horizontal Left or Right

Use an appropriate tool to pry out water deflector with two or three s-clips from the vertical drain pan. See Figure 13. Relocate the deflector with s-clips on the Horizontal Drain Pan lined up to the coil support bracket. See Figure 14. This positions the deflector below the feeder tubes to channel the condensate to the drain pan.

NOTE: The condensate deflector should be installed in the s-clip section which is inside the drain pan edge. See Figure 15.

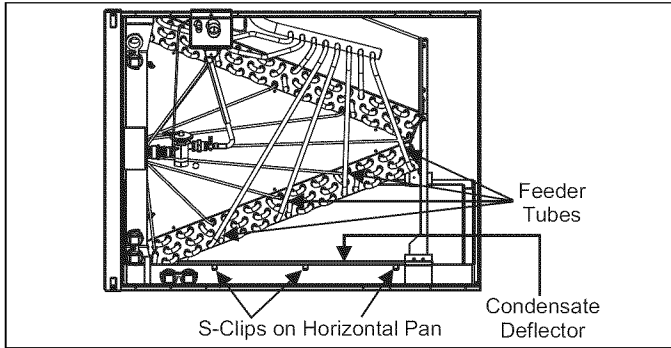

FIGURE 11: Condensate Deflector on Horizontal Drain Pan Edge

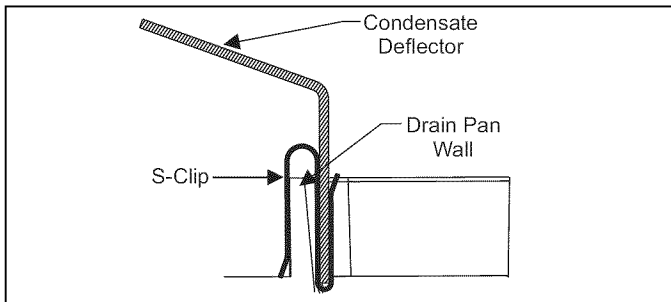

FIGURE 12: S-Clip Installation

SECTION VII: REFRIGERANT LINE CONNECTION

CAUTION
<p><i>Coil is under inert gas pressure. Relieve pressure from coil by removing rubber plug.</i></p>

CAUTION
<p><i>Dry nitrogen should always be supplied through the tubing while it is being brazed, because the temperature required is high enough to cause oxidation of the copper unless an inert atmosphere is provided. The flow of dry nitrogen should continue until the joint has cooled. Always use a pressure regulator and safety valve to insure that only low pressure dry nitrogen is introduced into the tubing. Only a small flow is necessary to displace air and prevent oxidation.</i></p>

Connect lines as follows:

NOTE: Route the refrigerant lines to the coil in a manner that will not obstruct service access to the coil, air handling system, furnace flue or filter.

1. Suction and liquid line connections are made outside the cabinet. Leave the tubing connection panel attached to the cabinet with the tubes protruding through it. Coil access panel should be removed for brazing. The lines are expanded to receive the field line set tubes.

2. Remove the heat shield from the Customer Packet, soak in water, and install over coil tubing to prevent overheating of cabinet.
3. Wrap a water soaked rag around the coil connection tubes inside the cabinet to avoid damaging the TXV bulb.
4. Remove grommets where tubes exit the cabinet to prevent burning them during brazing.
5. Purge refrigerant lines with dry nitrogen.
6. Braze the suction and liquid lines.
7. Remove the heat shield.
8. Re-attach the grommets to the lines carefully to prevent air leakage.
9. Attach the coil access panel to the cabinet.

Refer to Outdoor unit Installation Manual for evacuation, leak check and charging instructions.

Lines should be sound isolated by using appropriate hangers or strapping.

All evaporator coil connections are copper-to-copper and should be brazed with a phosphorous-copper alloy material such as Silfos-5 or equivalent. DO NOT use soft solder.

SECTION VIII: COIL CLEANING

If the coil needs to be cleaned, it should be washed with Calgon Cal-Clean (mix one part CalClean to seven parts water). Allow solution to remain on coil for 30 minutes before rinsing with clean water. Solution should not be permitted to come in contact with painted surfaces.

SECTION IX: AIR SYSTEM ADJUSTMENT

To check the CFM, measure the static pressure drop across the coil using a portable manometer and static pressure tips. To prepare coil for static pressure drop measurements - the system should have been recently operational in cooling mode.

NOTE: Table 7 below has WET coil data. Run system for approximately 15 minutes in cooling mode prior to taking measurements.

Drill 2 holes, one 3" after the coil (before any elbows in the ductwork) and one 3" before the coil. Insert the pressure tips and read the pressure drop from the manometer. See Table 5 to determine the air flow, and make the necessary adjustments to keep the CFM within the air flow limitations of the coil.

TABLE 7: Air Flow Data - Static Pressure Drop

Coil Size	CFM @ Static Pressure Drop - IWG (Based on wet coil)				
	0.10	0.15	0.20	0.25	0.30
18A	400	550	710	880	1000
18B	425	620	830	970	1125
24A	400	600	800	950	1075
24B	425	725	900	1075	1215
30A	425	600	800	950	1075
30B	450	725	900	1075	1215
32A	555	725	865	970	1080
35B	600	800	950	1090	1220
35C	792	1007	1206	1382	1572
36A	625	775	925	1025	1125
37A	689	880	1031	1180	1300
36B	825	976	1174	1300	1450
36C	975	1225	1375	1575	1775
42B	825	1000	1175	1325	1450
42C	1025	1275	1475	1650	1850
43C	785	1025	1210	1400	1570
48C	900	1075	1300	1475	1600
48D	1008	1224	1451	1620	1788
60D	1160	1432	1598	1750	1870
62D	1240	1532	1709	1870	2000
64D	1152	1362	1573	1783	1994

SECTION X: INSTALLATION VERIFICATION

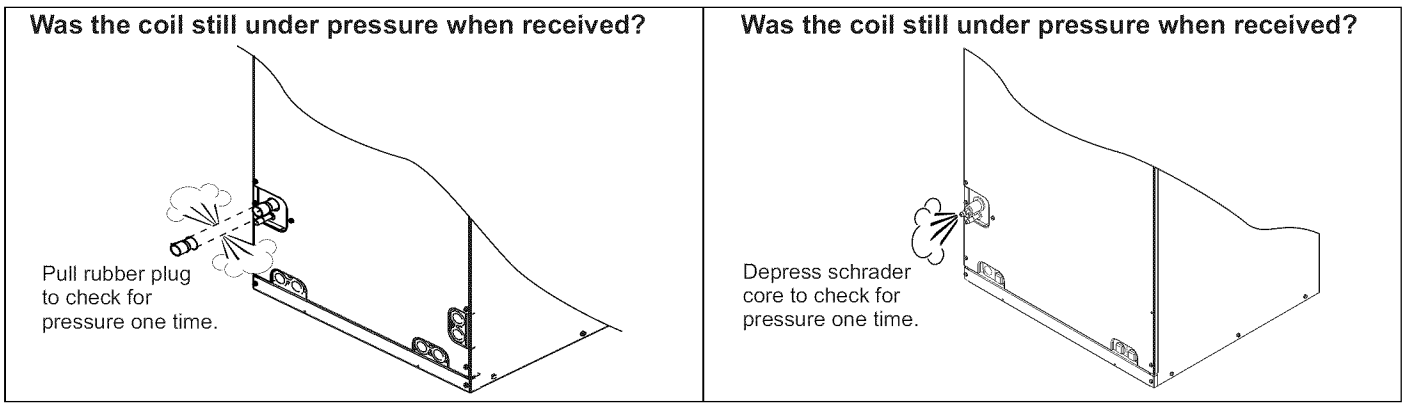

FIGURE 13: Pressure Check

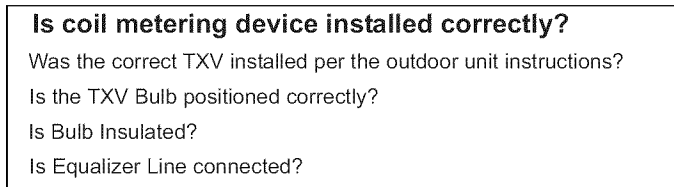

FIGURE 14: TXV Check List

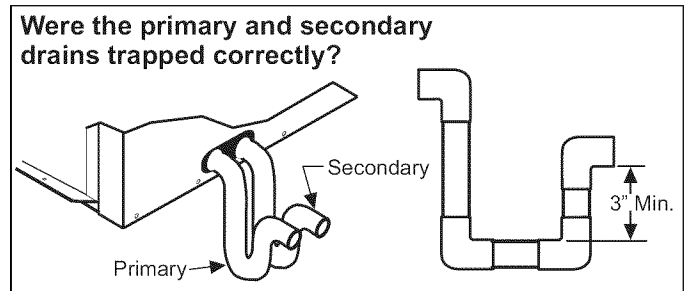

FIGURE 15: Drain Traps

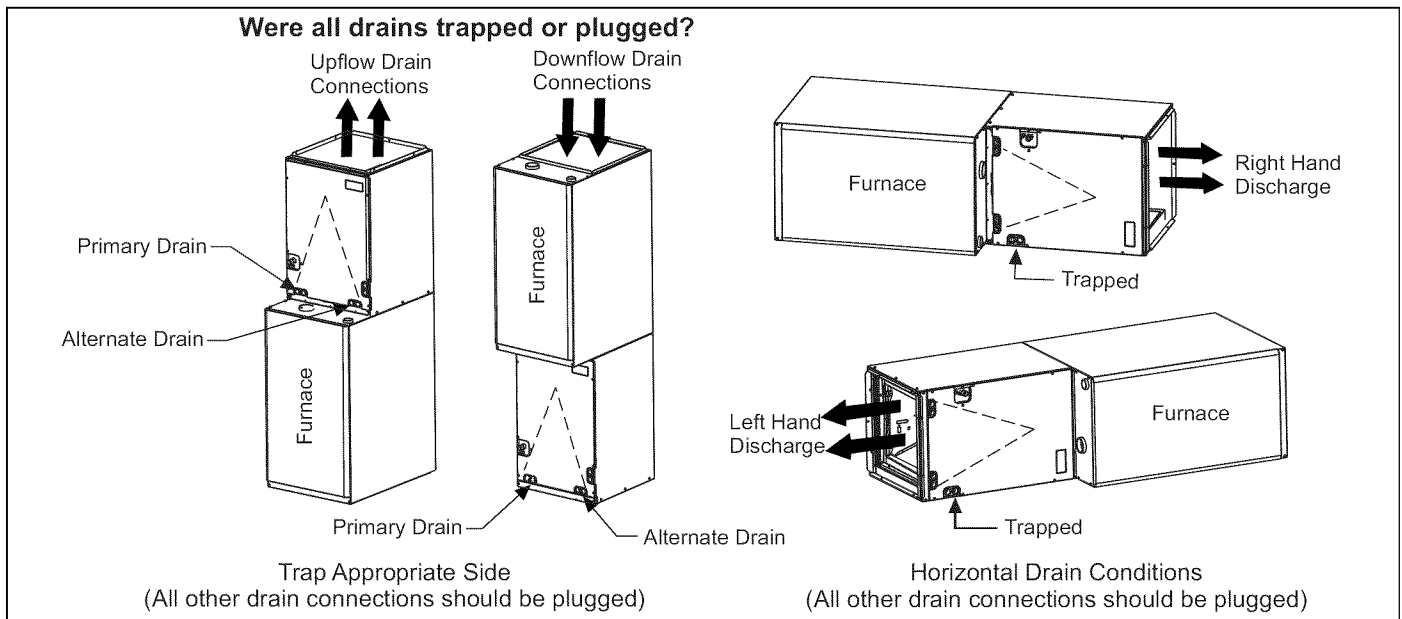

FIGURE 16: Location of Trapped and Plugged Drain Connections