

dy

U 113
.2
TM
1943

TM 1-1050

U.S. Dept of Army

WAR DEPARTMENT
TECHNICAL MANUAL

**FUNDAMENTALS OF
MECHANICAL DRAWING**

March 24, 1943



U113
.2

TM 1-1050
1943
★ ★

TM 1-1050
1

TECHNICAL MANUAL }
No. 1-1050 }

WAR DEPARTMENT,
WASHINGTON, March 24, 1943.

FUNDAMENTALS OF MECHANICAL DRAWING

	Paragraphs
SECTION I. General.....	1
II. Equipment and materials.....	2-16
III. Lettering and lines.....	17-18
IV. Geometric constructions.....	19-34
V. Orthographic projection.....	35-37
VI. Pictorial drawing.....	38-42
VII. Sectional views and threaded parts.....	43-44
VIII. Scales, dimensions, and notes.....	45-47
IX. Technical sketching.....	48
X. Sheet metal drafting.....	49-52
XI. Representative working drawings.....	53

SECTION I

GENERAL

	Paragraph
General.....	1

1. **General.**—*a.* (1) The design, construction, and repair of machines or structures involve a mass of detail with respect to specific parts. A complete written or oral description of detailed units would necessitate a lengthy, complex discussion which would tend to confuse and retard the progress of the workman. It is more efficient to present the various design features in the form of a drawing, showing various views, so that details of construction may be readily interpreted. The use of a drawing containing dimensions, notes, etc., for further simplification, presents to the workman clear, concise information.

(2) A drawing is made with the aid of instruments and other equipment, in which form it is known as a mechanical drawing, or it is made as a freehand sketch. The execution of such drawings requires skill, accuracy, and an understanding of the subject matter. In the various industries, practices may vary as to the manner of presentation of information in mechanical drawings, but the manner of execution of such drawings is common to all.

M558387

(3) The purpose of this manual is to familiarize the student mechanic with the basic principles of mechanical drawing and general practices relevant thereto. Only subject matter considered essential for use in basic courses in mechanical drawing has been included. Tables of limits, classes of fits, standard dimensions of threads, etc., have been omitted, as such subject matter more appropriately pertains to the more advanced and specialized courses in drafting. When the need arises for information of this type, reference should be made to handbooks containing such tables.

b. As a rule, the use of original drawings would be impractical. The circulation of the drawing would be limited and would soon be destroyed or rendered illegible as a result of wear. Therefore, duplicates are prepared for use in the work of production, maintenance, etc. The drawing is first traced in ink or pencil, using translucent cloth or paper; or in some instances, the original drawing is executed on tracing paper. The drawing may be duplicated by exposing it to an intense light while in contact with an especially prepared sensitized paper. After exposure to the light, the exposed paper is treated with certain chemicals which develop the image. There are numerous printing processes and types of paper which may be used for drawing reproduction. The final product or print may have white lines on a blue background, white lines on a brown background, black lines on a white background, or red lines on a white background, depending upon the process and type of paper used. Blueprints, Van Dyke prints, Ozalid prints, and photostat prints are some of the most common types of reproductions.

c. (1) There apparently is little uniformity in the size of drawings. In many instances the size of the sheet is selected to suit the object to be drawn. Often, however, the standard letter-size sheet of 8½ by 11 inches is used for small drawings. For larger drawings, multiples of this size, as shown below, are used. This range facilitates folding prints into suitable sizes for filing in letter-size filing cabinets. The 42-inch size is an exception, but is used for purposes of economy.

Width (inches).....	8½	11	11	17	17	17	22	25½	34	34	34	42	42
Length (inches).....	11	17	34	22	42	66	34	42	42	66	88	66	88

(2) In addition to dimensions and notes, certain other data are associated with a drawing. These data usually include the title, number, scale, material, finish, changes, patent clauses, etc., set out in blocks. Figure 1 shows the arrangement of such data on a drawing form used by the Army Air Forces.

d. The subject matter and illustrations contained in this manual,

with respect to line work, arrangement of views, symbols, sectional views, dimensioning, and screw thread representation, is generally in accordance with principles approved by American Standards Association in publication entitled "American Standard Drawings and Drafting Room Practice."¹

SECTION II

EQUIPMENT AND MATERIALS²

	Paragraph
Drawing board.....	2
Paper and cloth.....	3
Pencils.....	4
Erasers.....	5
T-square.....	6
Triangles.....	7
Irregular curve.....	8
Triangular scale.....	9
Protractor.....	10
Ruling pen.....	11
Lettering pens.....	12
Compass.....	13
Dividers.....	14
Bow instruments.....	15
Care of equipment.....	16

2. Drawing board.—A drawing board or table is used to provide a flat, smooth surface for the paper while the drawing is being made, and also provides a straight edge for guiding the T-square. A typical drawing board, with T-square and drawing paper in place, is shown in figure 2.

3. Paper and cloth.—*a.* Drawing paper is available in a variety of grades, in sheets or rolls, in colors of white, cream, or buff. For general pencil work, a paper with slight grain and good erasing qualities is desirable. Thin, tough, translucent paper which is transparent with close contact is used to trace copies in pencil or ink. Tracing paper is also used for original pencil drawings. Fine linen cloth, treated so as to make it translucent and smooth, is generally used for ink tracing. The dull side of the cloth is used and, prior to inking, the surface is lightly sprinkled and rubbed with powdered chalk or soapstone. Where an erasure has been made, the cloth is again treated with chalk or soapstone.

b. The paper should be placed with one edge near the left edge of

¹ Permission granted by American Society of Mechanical Engineers.

² The subject matter and illustrations on use of equipment are based upon information contained in publication "Use and Care of Drawing Instruments," by Eugene Dietzgen Co., with their permission.

the table or board, and with its top edge parallel to the upper edge of the T-square blade when the head of the T-square is held firmly against the left edge of the board. The corners of the paper are then fastened by means of an adhesive (masking or cellulose tape), care being exercised to have the paper smooth. Thumbtacks are occasionally used but are not as suitable as tape.

4. Pencils.—*a.* Drawing pencils are graded by letters from 6B (softest) through 5B, 4B, 3B, 2B, B, HB (medium soft), F, H (me-

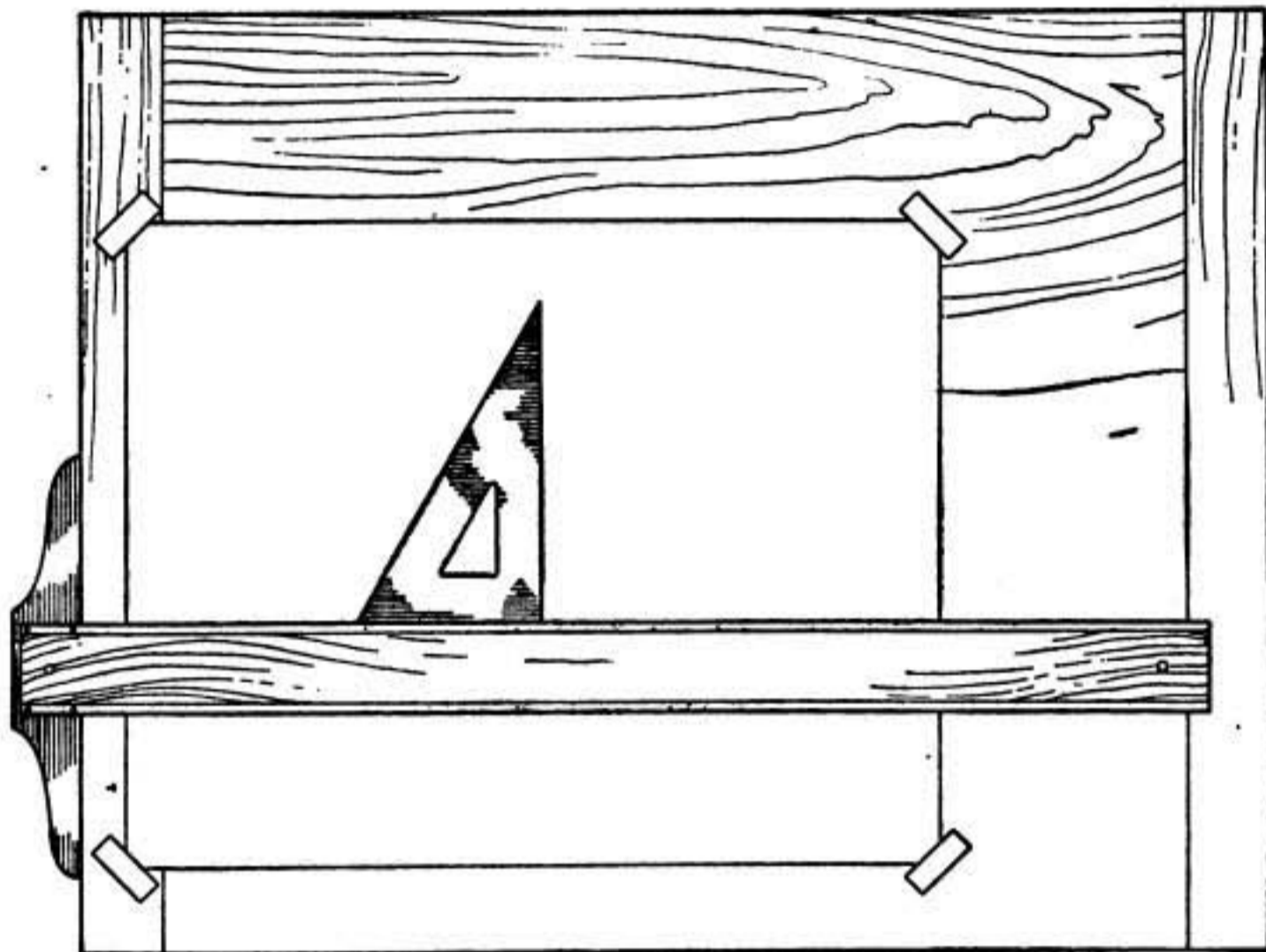

FIGURE 2.—Drawing board with T-square.

dium hard), 2H, 3H, 4H, 5H, 6H, 7H, 8H, to 9H (extremely hard). Grades 4H and 6H are generally used for drawing lines while grades F, H, and 2H are preferred for lettering and sketching.

b. The pencil is sharpened with a knife or pencil sharpener so that approximately $\frac{1}{4}$ to $\frac{3}{8}$ inch of the lead is exposed. A conical point of desired fineness may be obtained by rubbing back and forth on a sandpaper pad (fig. 3) rotating the pencil at the same time to avoid irregularly shaped sides on the point. The double bevel wedge point may be used for straight-line work. This type of point does not require sharpening as frequently as a conical point.

c. When drawing lines, the pencil is held almost vertically (slightly tilted away from draftsman) with only a slight incline in the direction

of pencil movement. If the pencil has a conical point, frequent rotation will help preserve the sharpness of the point.

5. Erasers.—*a.* A soft rubber eraser is required for erasing pencil lines, while a medium hard rubber eraser is best for erasing ink lines. A soft gum eraser is satisfactory for cleaning finished drawings.

b. When using an eraser, light, firm strokes should be made in one

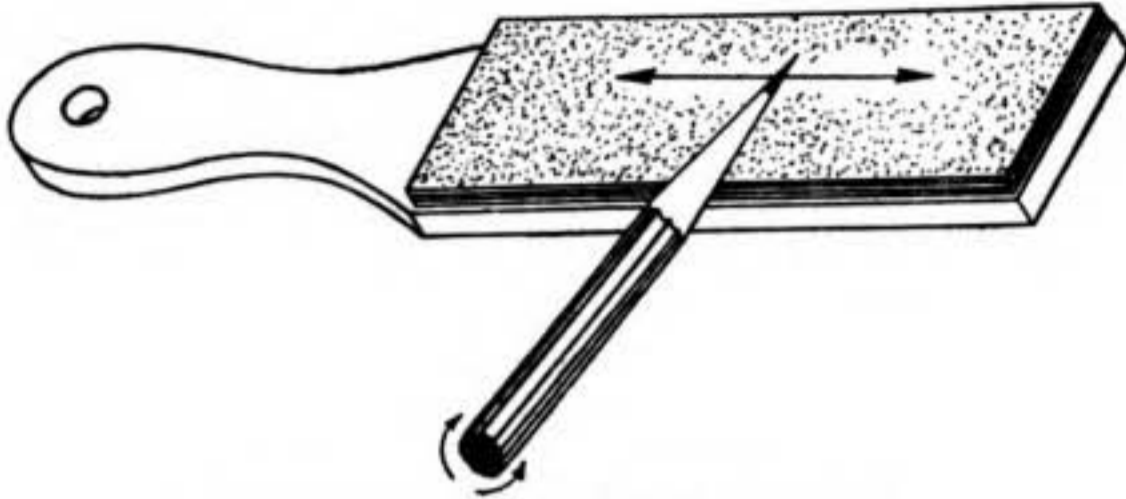

FIGURE 3.—Method of pointing pencil lead.



FIGURE 4.—Use of erasing shield.

direction only, keeping the paper taut with the thumb and second (middle) finger. An erasing shield (fig. 4) should be used whenever practicable to protect parts of the drawing which are not to be erased.

6. T-square.—*a.* The T-square (fig. 5①) generally consists of a wooden blade with transparent celluloid edges, securely fastened at right angles to a head by means of screws.

b. The T-square is used for drawing horizontal lines and as a guide for drawing lines with triangles. When placed on the board (or table), the head of the T-square is held firmly against the left edge of

the board, and only the upper, or working edge, of the blade is used. The T-square is moved by sliding the head along the edge of the board with the left hand. After the working edge is located as desired, the left hand may be used to steady the blade. Left-handed draftsmen use the right side of the board and the right hand. If a drawing is removed from the board before it is completed and the work is again resumed, the drawing should be trued with the T-square and one of the lines of the drawing, not with the edge of the paper.

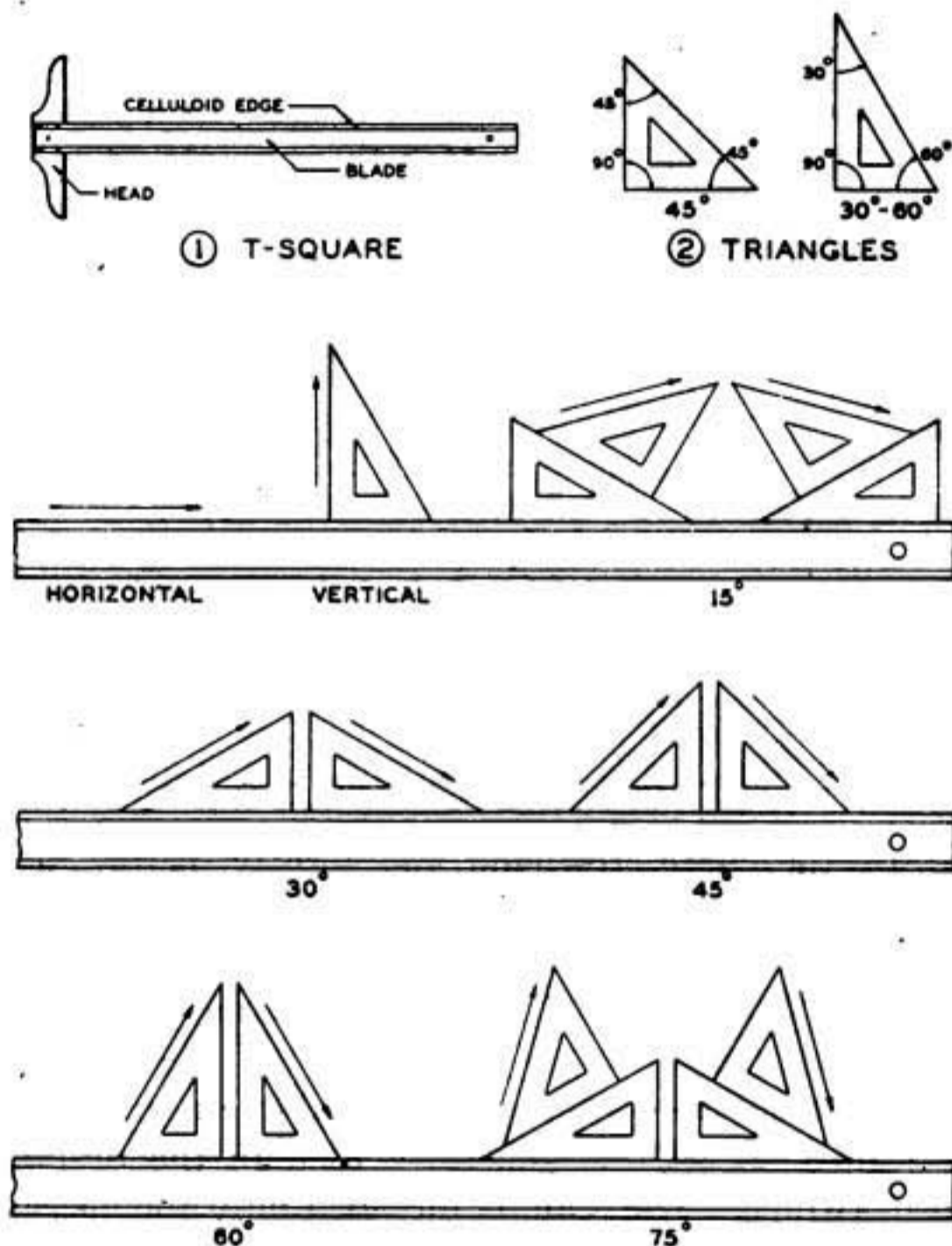

③ DRAWING LINES WITH T-SQUARE AND TRIANGLES
 FIGURE 5.—T-square, triangles, and their application.

7. Triangles.—*a.* Triangles commonly used are of two types, the 45° and the 30° to 60° (fig. 5②), and are usually made of transparent celluloid.

b. Triangles, in combination with the T-square, are used in the construction of vertical and inclined lines. Figure 5③ illustrates the common angles constructed with the use of triangles and the T-square. Arrows indicate the direction in which the lines are drawn.

a. Two triangles may be used to draw a line parallel to a given line AB , figure 6①. Place a triangle in position so that one of its edges coincides with the line and place a second triangle against an edge of the first triangle. Hold the second triangle firmly in place, slide the first triangle to the desired position (fig. 6②), and draw the parallel line. A line perpendicular to the parallel lines could be drawn with the same position of the triangle, as shown in figure 6③. A T-square blade may be used in place of the second triangle.

8. Irregular curve.—*a.* The irregular or "French" curve is used to draw a smooth curve which is not a true circle or an arc thereof. Points are first determined to locate the curve which is to be drawn, and the irregular curve fitted to match these points (fig. 7). When drawing the curve, successive sections are blended into one another to form a smooth continuous outline. A common procedure is to

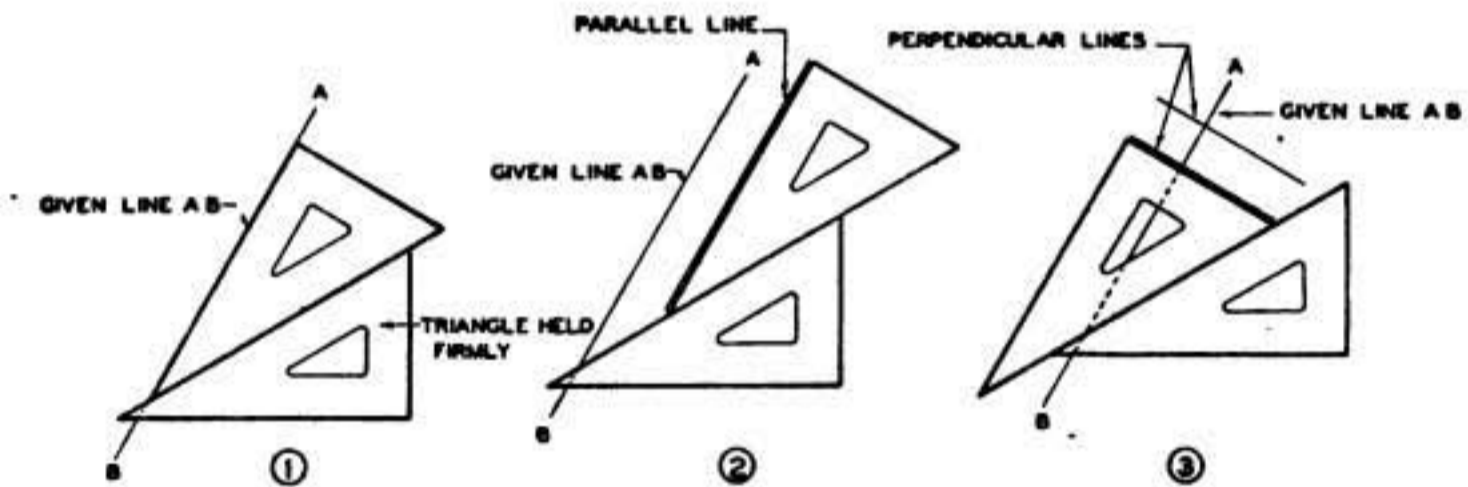

FIGURE 8.—Method for drawing parallel and perpendicular lines.

carefully draw the curve, freehand and lightly, before accomplishment with the irregular curve.

b. Individual irregular curves of various shapes are available in sets. Individual curves are used in the same manner as the composite curve shown.

9. Triangular scale.—*a.* The mechanical engineer's or architect's triangular scale (fig. 8①) is generally used in the preparation of mechanical drawings. The scale is intended only for measuring and should not be used as a straightedge. It has eleven sets of graduations or scales. At each end of the scales (except the full-size scale) is a number indicating the size of the main divisions on that scale. Numbers (upright) at the right end are read to the left, and those (upright) at the left end are read to right. When a scale on the left end is used, foot measurements are read to the right of the zero point and inch measurements are read to the left (fig. 8④). Conversely, when a scale on the right end is used, foot measurements are read to the left of the zero point and inch measurements to the right (fig. 8⑤).

b. The full-size scale is used for drawings of the same size as the objects they describe. This scale (fig. 8②) is indicated by its number, 16, which denotes that it is divided into sixteenths of an inch. An object which is too large to be drawn to full-size scale is drawn to reduced scale. A reduced scale permits the use of smaller measuring units on

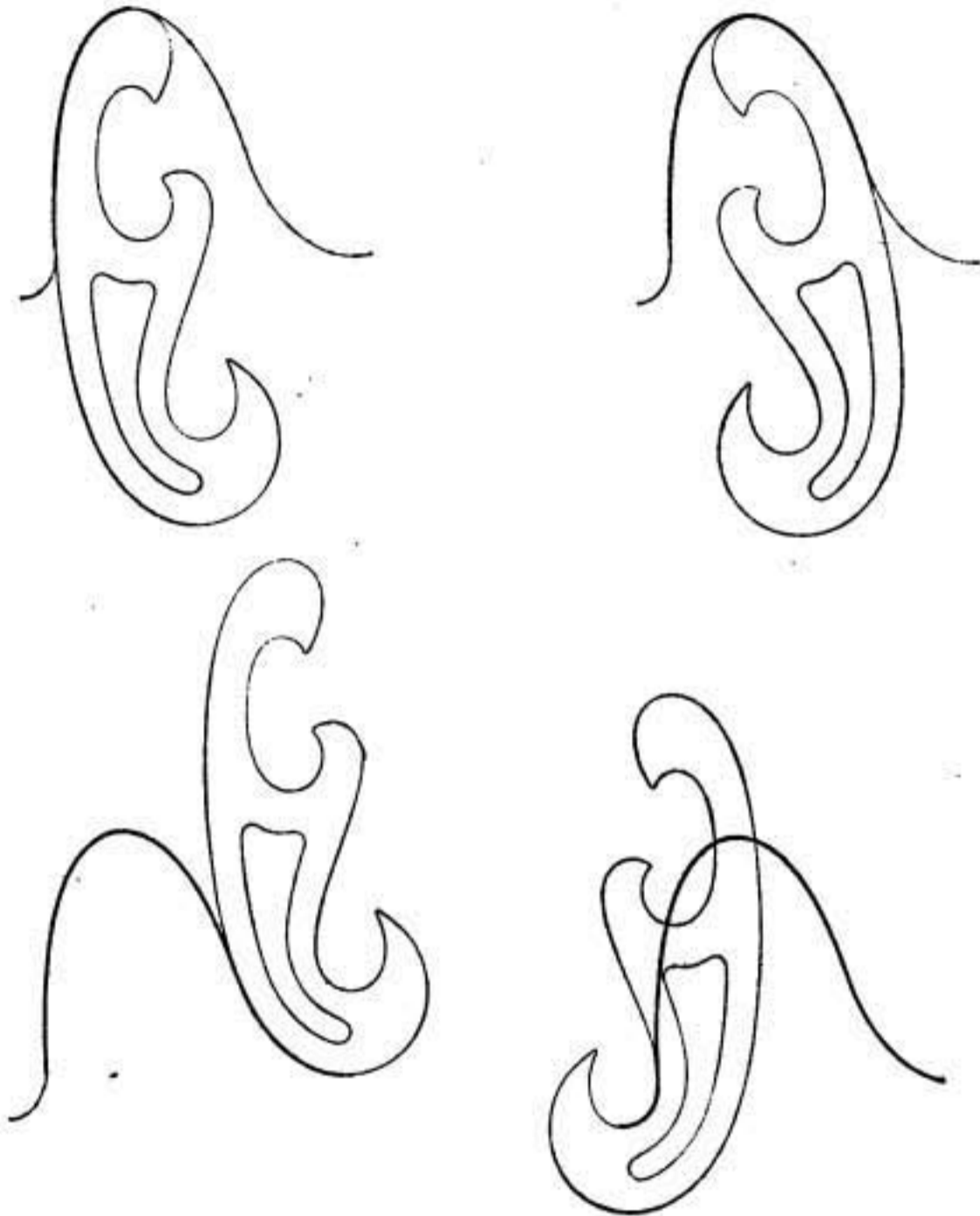
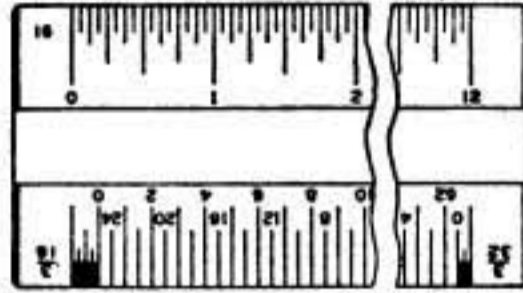
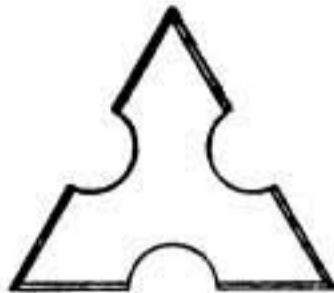

FIGURE 7.—Use of irregular curve.

the drawing; however, dimensions are never divided mathematically to reduced values but are always given full size. All reduced scales, except the $\frac{3}{32}$ - and $\frac{1}{8}$ -inch scales, are divided into twelve or more parts on the inch side of the zero point, representing the 12 inches and fractions of inches of that scale foot. The $\frac{3}{32}$ - and $\frac{1}{8}$ -inch scales have only six subdivisions on the inch side of the zero point, each subdivision representing 2 inches. Care should be exercised in reading the inch divisions in order to determine the correct inch unit or fractional

inch unit for the particular scale. Examples of scale reductions are as follows:

(1) The scale of 3 inches equals 1 foot, marked "3" (fig. 8③), is used when the representation of the object is to be reduced so that 3 inches on the drawing is to be equivalent to 1 foot on the object. Accordingly, the 3 inches on the scale is divided into twelve 1-inch



① TRIANGULAR SCALE

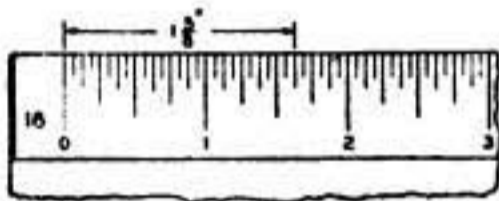

② FULL SCALE

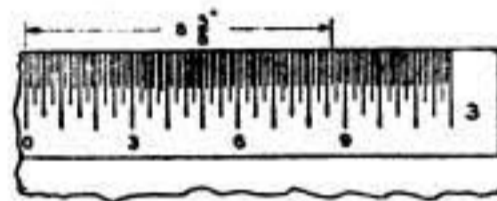

③ 3" SCALE

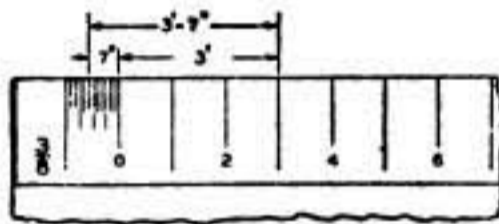

④ 3/8" SCALE

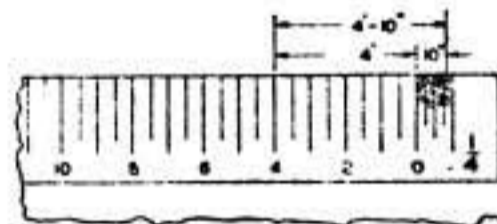

⑤ 1/4" SCALE

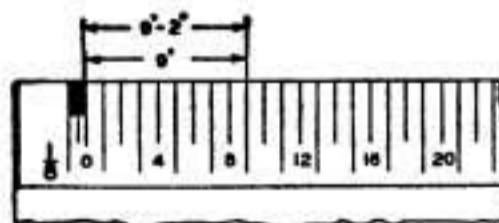

⑥ 1/8" SCALE

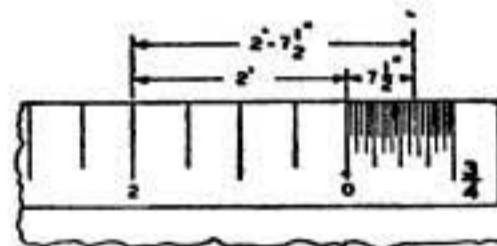

⑦ 3/4" SCALE

FIGURE 8.—Mechanical engineer's or architect's triangular scale.

divisions; each inch division is further divided into eighths. The figure shows how $8\frac{5}{8}$ inches would be measured using this scale.

(2) The $\frac{3}{8}$ -inch scale reduces 1 foot on the full-size object to $\frac{3}{8}$ inch on the drawing. To reduce a dimension of 3 feet 7 inches to this scale (fig. 8④), count three of the foot divisions to the right of the zero for the foot measurement, and seven of the inch divisions to the left of the zero for the inch measurement.

(3) The $\frac{1}{4}$ -inch scale reduces 1 foot on the full-size object to $\frac{1}{4}$ inch on the drawing. To reduce a dimension of 4 feet 10 inches to this scale (fig. 8⑤), count four of the foot divisions to the left of the zero, and ten of the inch divisions to the right of the zero.

(4) The $\frac{1}{8}$ -inch scale reduces 1 foot on the full-size object to $\frac{1}{8}$ inch on the drawing. To reduce a dimension of 9 feet 2 inches to this scale (fig. 8⑥), count nine of the foot divisions to the right of zero and one 2-inch division to the left (each division is 2 inches).

(5) The $\frac{3}{4}$ -inch scale reduces 1 foot on the full-size object to $\frac{3}{4}$ inch on the drawing. To reduce a dimension of 2 feet $7\frac{1}{2}$ inches to this scale (fig. 8⑦), count two of the foot divisions to the left of zero and seven and one-half of the inch divisions to the right.

c. The civil engineer's scale (not illustrated) consists of inches subdivided into tenths, twentieths, thirtieths, etc., and is adaptable for work on charts, maps, etc.

• **10. Protractor.**—The protractor (fig. 9) is used for setting off or measuring angles. The protractor illustrated is graduated from 0° to 180° in divisions of 1° . Protractors are also available with smaller divisions. The protractor is placed with its reference line over the line on the paper and its center mark or hole at the point on the line where the angle is to be drawn. The required angle may then be found on the outer edge of the protractor and the paper marked at this division. With protractor removed, a straight line is drawn through the point just found and the point with which the center of the protractor coincided, thus giving the required angle.

11. Ruling pen.—The ruling pen (fig. 10①) consists of steel blades attached to a handle, and a thumbscrew for adjusting the distance between the points (nibs) of the blades to obtain the desired width of line. The ruling pen is used for inking straight lines and irregular curves. The pen is filled with ink (fig. 10②) by means of a quill which is fastened to the stopper of the drawing ink bottle. The height of the column of ink in the point should not exceed $\frac{1}{4}$ inch. The pen should be held in a nearly vertical position against the straightedge with the nibs parallel to the edge (fig. 10③), and the handle inclined slightly in the direction of line. If the pen point is inclined toward the straightedge it will raise the inside nib, causing the ink to run under the straightedge and resulting in a blotted line. If the pen point is inclined away from the straightedge, it raises the outside nib, resulting in a ragged line. The pen is supported by the second finger with the straight blade adjacent to the straightedge, and held between the thumb and first (index) finger as shown in figure 10④.

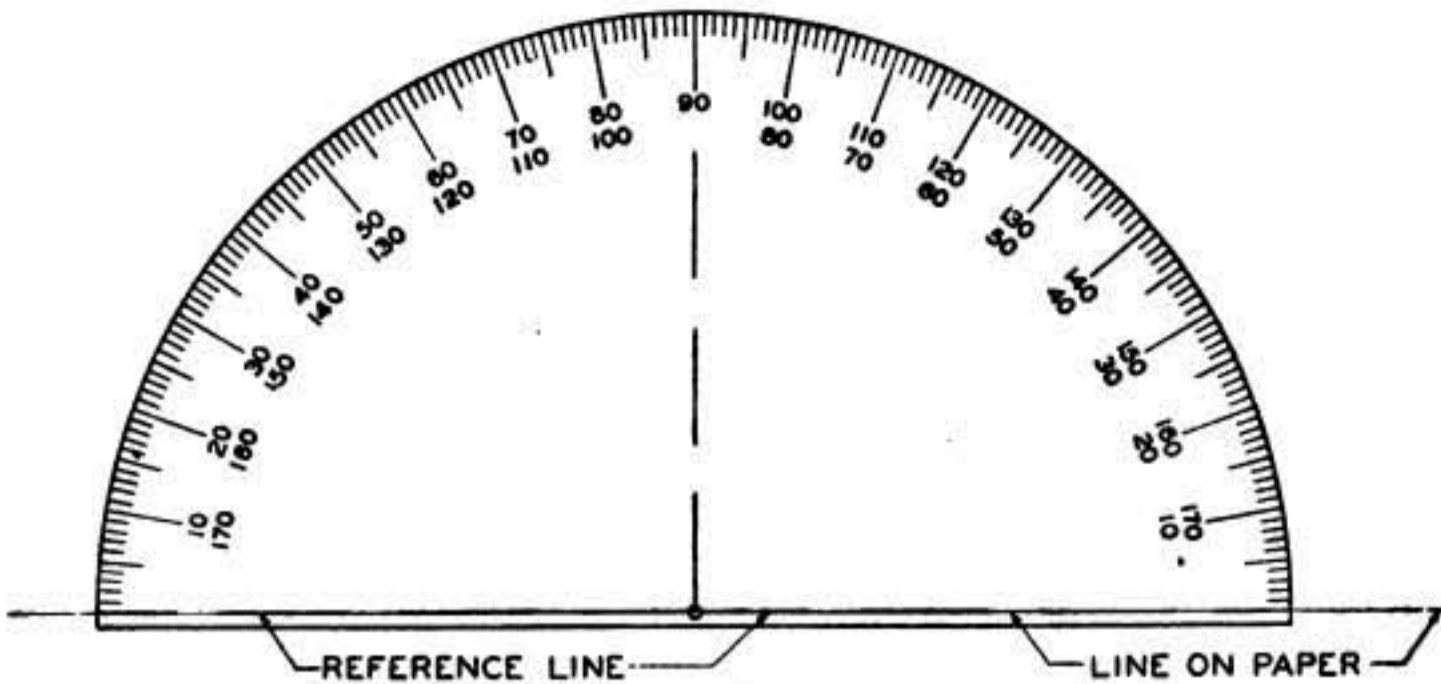

FIGURE 9.—Protractor.

12. Lettering pens.—Inked lettering is done with a great variety of line weights and decorative effects. The various forms of lettering require numerous special pens. These pens are so designed that lines of any width may be drawn by the correct application of the proper pen. Each company manufacturing pens has its particular styles and grades of size. Pens range from very fine sizes for drawing hair lines to the extra heavy sizes used by sign writers for lines up to an inch in width. The selection of styles and sizes will generally be determined by choice of the draftsman and the special requirements of the task at hand. The examples of pens shown in figure 11 are typical styles of pens commonly used in freehand lettering; other styles and sizes will be used as the student gains experience and knowledge.

13. Compass.—*a.* Drawings are a combination of straight and curved lines, the curved lines being circles or parts of circles generally drawn with the compass. The compass consists of two legs hinged at the top to permit adjustment to the desired spread. One leg may be used interchangeably with a pencil leg, pen leg, and a lengthening or extension bar as shown in figure 12. The needle point of the compass is adjusted to extend approximately $\frac{1}{64}$ inch beyond the pen or pencil point, and the lead of the pencil leg should be beveled on the outside for approximately $\frac{3}{16}$ inch, as shown in figure 12(1).

b. The compass is used with one hand. It may be opened with the second finger and thumb (fig. 13(1)) and set to the desired radius by placing the needle point at the center mark, adjusting the spread with the second and third fingers (fig. 13(2)). After the radius is set, the thumb and first finger are raised to the handle (fig. 13(3)). The compass is started at the near side of the circle to be drawn and revolved clockwise as shown in figure 13(4), inclined slightly in the direction

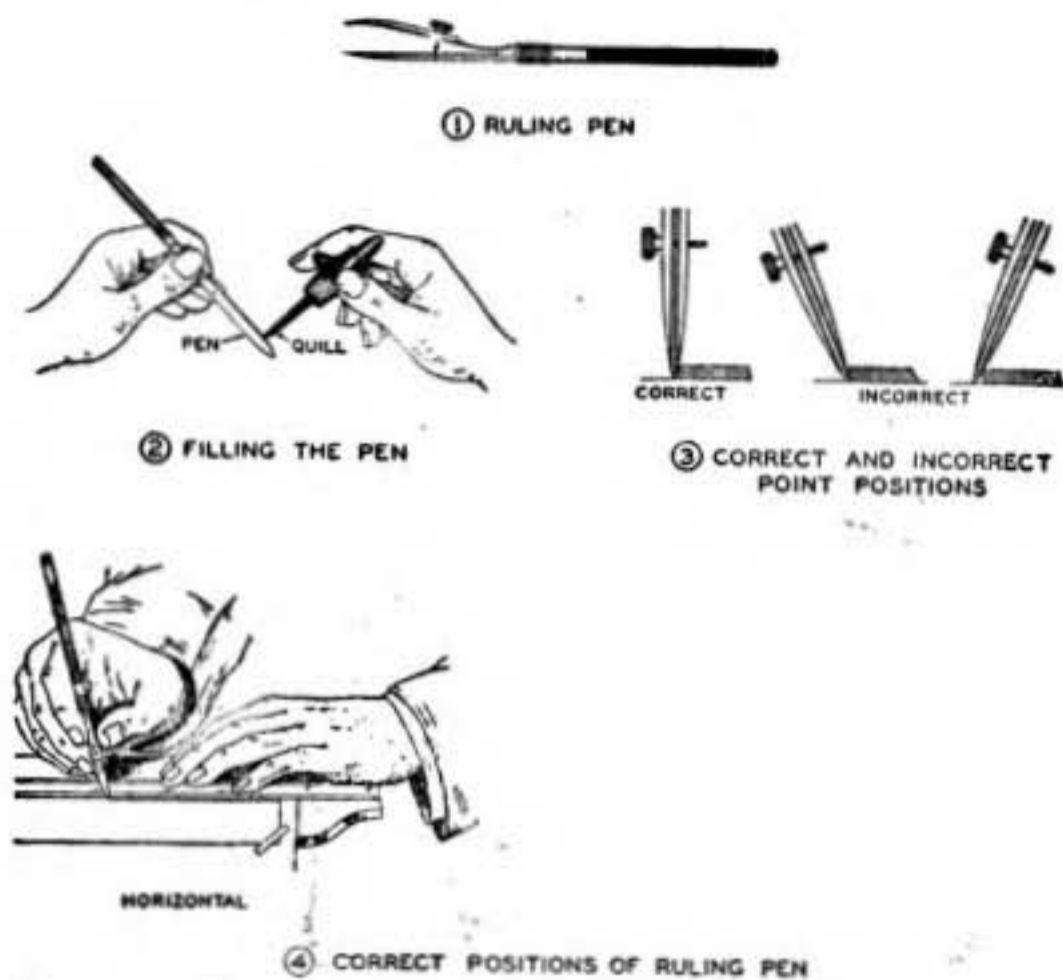

FIGURE 10.—Ruling pen and method of use.

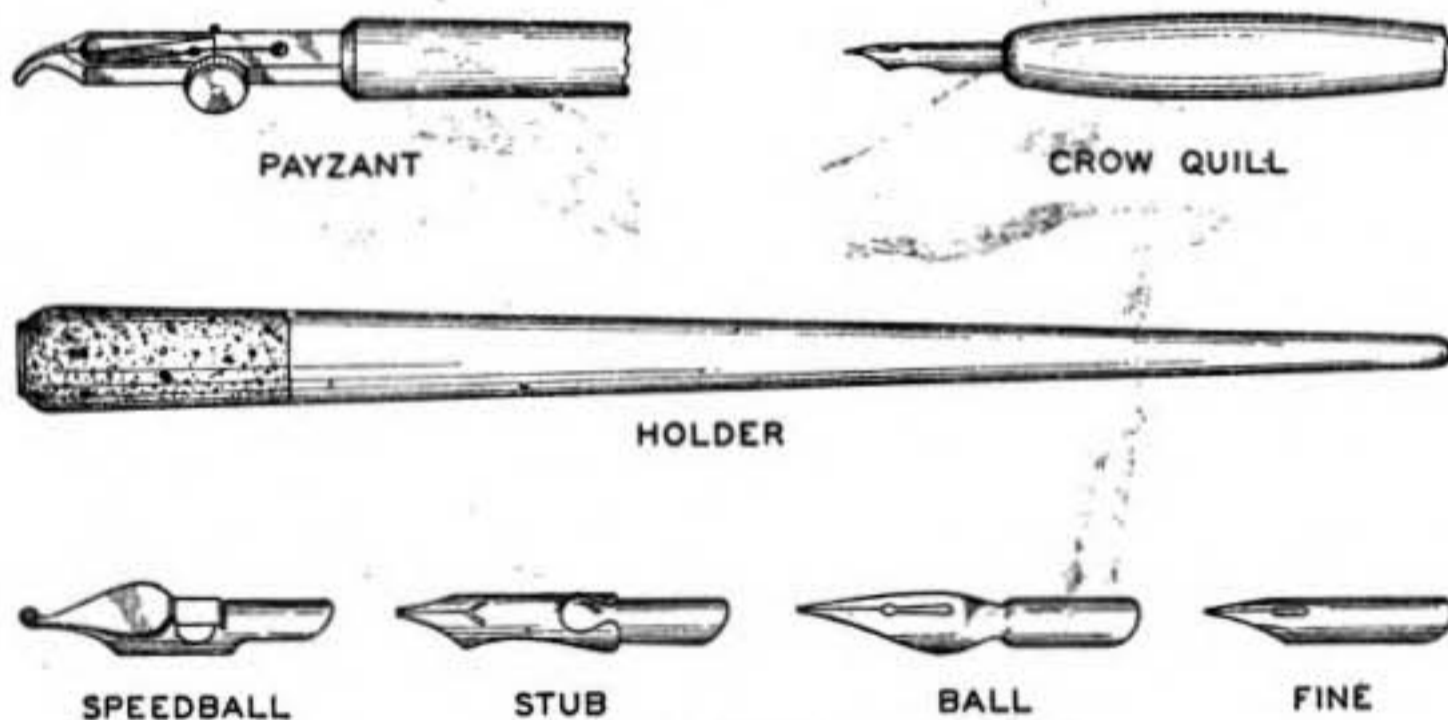

FIGURE 11.—Lettering pens.

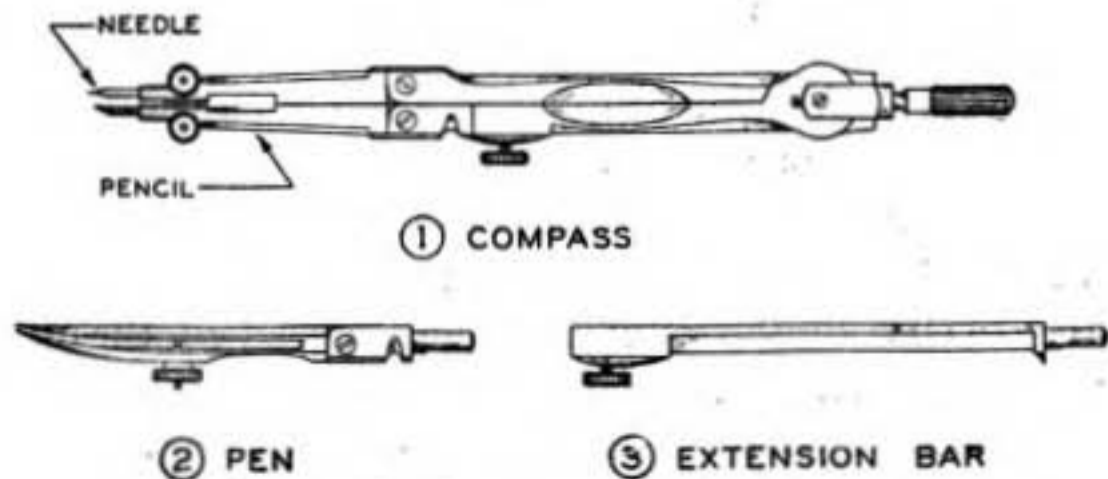

FIGURE 12.—Compass and its parts.

of the line. To draw a circle with a radius of approximately $1\frac{1}{2}$ inches, the pencil leg may be straight. For a larger circle, and always when using the pen leg, the legs of the compass should be adjusted perpendicular to the paper (fig. 14①). The extension bar is used to lengthen the pencil or pen leg of the compass to permit the drawing of large circles. Adjustment of the compass, using the extension bar, is shown in figure 14②. To avoid changing the radius, a circle is never drawn by holding the legs of the compass.

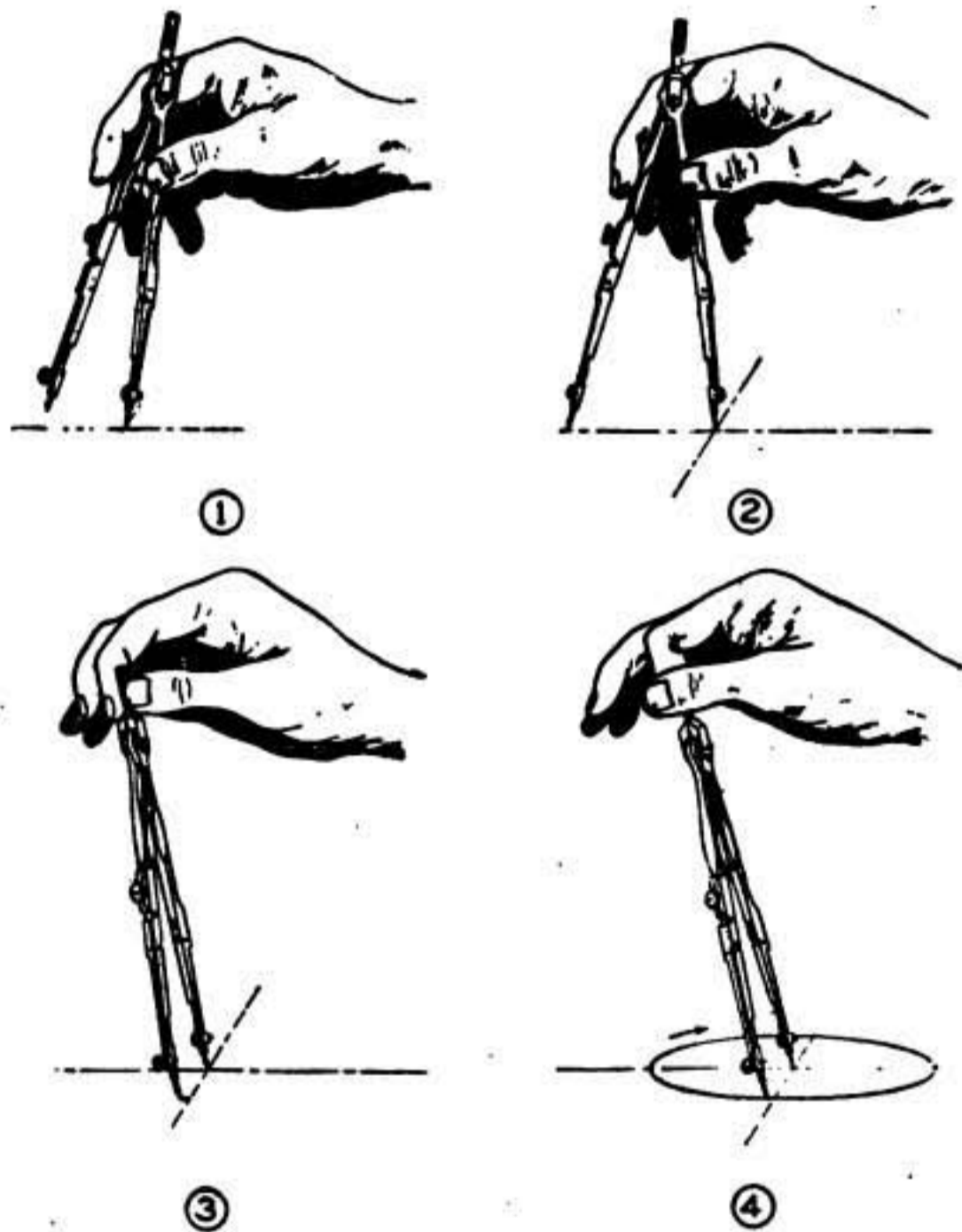

FIGURE 18.—Use of compass.

14. Dividers.—This instrument is similar to the compass except that both legs are equipped with points (fig. 15①). It is used to transfer measurements on drawings, and for dividing a line into equal parts. Figure 15② shows the method of dividing a line into three equal parts by use of the dividers. The spread of the instrument is adjusted to approximately one-third the length of the line. This spread of distance is stepped off as shown by alternately swinging the dividers to either side of the line. If three of such distances do not

equal the length of line, the setting of the dividers is increased or decreased (as the case may be) by one-third of the error. This trial and error method is continued until exact division is obtained.

15. **Bow instruments.**—The use of the bow instruments (fig. 16①) is confined to small dimensions. For major adjustment of the bow instrument (fig. 16②), time is saved and wear of the threads avoided by holding the legs together while turning the adjusting

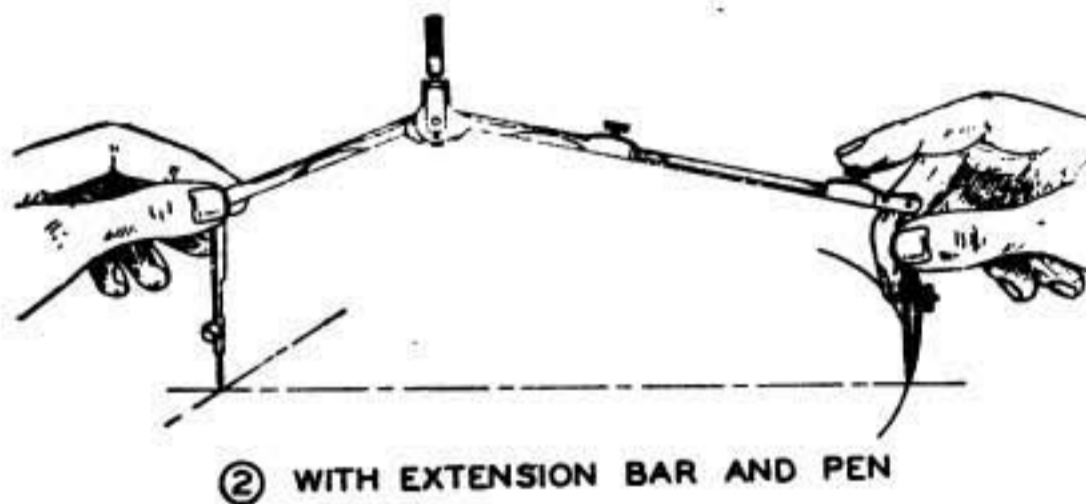

FIGURE 14.—Adjustments with pen leg and extension bar.

nut. After adjustment, the legs are gently released. A minor adjustment is made with the instrument in position and the point slightly raised as shown in figure 16③. After use, the instrument is opened to almost its full spread to release spring tension.

16. **Care of equipment.**—Proper care will lengthen the service of equipment and promote neat and accurate work.

a. Each drawing instrument should be kept in its proper place in the instrument case when not in use. The drafting table should not be cluttered with idle instruments and tools.

b. A knife edge or abrasive should never be used to clean instruments. Such cleaning should be accomplished frequently with a soft cloth.

c. Ink should not be permitted to dry in the nibs of the ruling pen or ink leg. Dried ink should be removed with a moistened cloth.

d. A lettering pen is not dipped into the ink; use the quill for the ruling pen (fig. 10). Frequently wipe the points on a soft cloth to prevent clogging. Clean the pen before putting it away, using warm water, and thoroughly dry it with a soft cloth. Never change the kind of ink on one point without first cleansing the point.

e. The joints of the compass and dividers should not be oiled.



① DIVIDERS

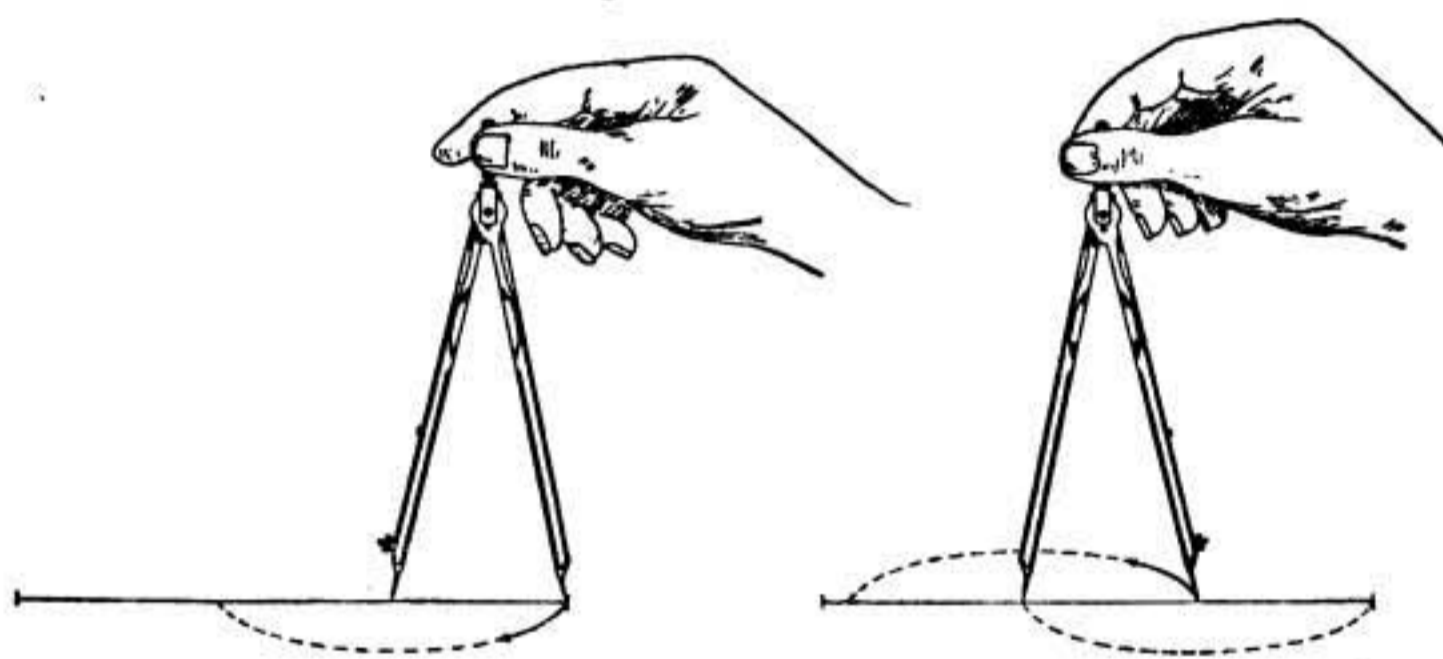

② USING THE DIVIDERS

FIGURE 15.—Dividers and their use.

f. After considerable usage, pen nibs may become dull and worn. The nibs may be restored to their slightly rounded original shape by stroking them (screwed together) with a pendulum sweep on a fine Arkansas stone. The nibs are then separated and individually sharpened on the outside with sliding and rolling motion. The nibs should match perfectly and should not be beveled or scratched on the inside. When the pen is properly sharpened it will draw the finest lines without leaving ragged edges or cutting the paper.

g. Care should be exercised to avoid damage to triangle and T-square edges. Celluloid equipment may be cleaned with a little soap and cold water.

h. Care should be exercised when a compass or dividers are adjusted on the scale, as the needle points may damage the surface of the scale.

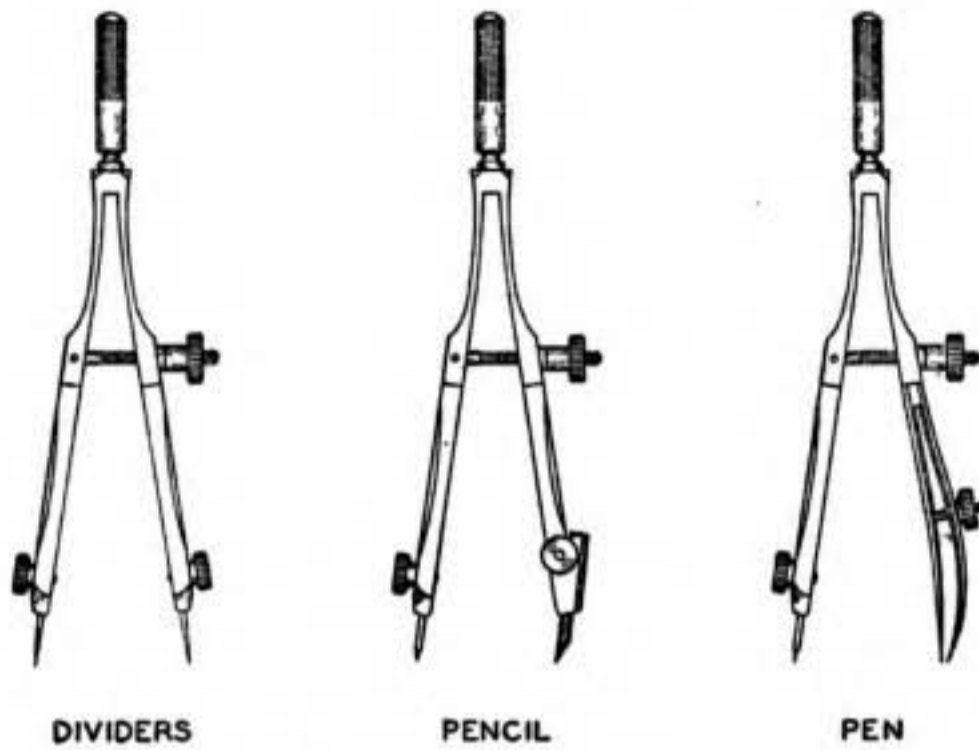

① THREE TYPES

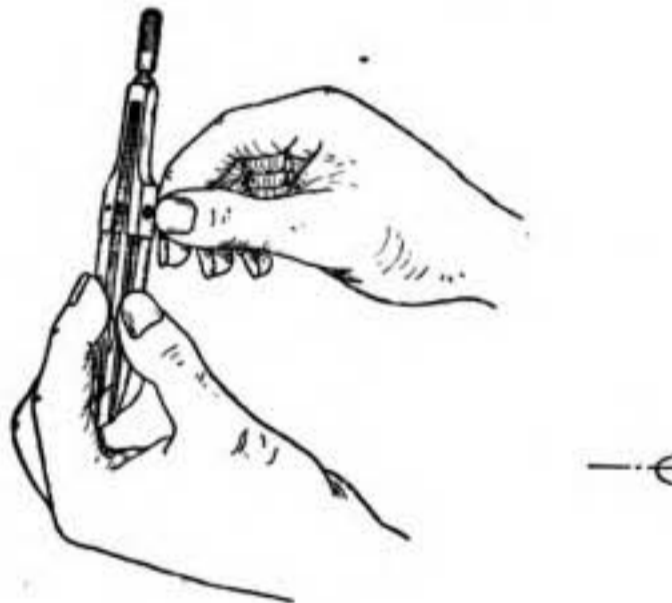

② MAJOR ADJUSTMENT ③ MINOR ADJUSTMENT

FIGURE 16.—Bow instruments and manner of adjustment.

SECTION III

LETTERING AND LINES

	Paragraph
Lettering.....	17
Lines.....	18

17. Lettering.—Lettering, in addition to numerals, is employed on drawings to provide legible presentation of notes, dimensions, and other information. Single stroke (lines forming the letters being the width of one stroke of the pencil or pen) vertical and single stroke inclined letters are commonly used in mechanical drawings. These styles of lettering may be easily accomplished, and present a simple,

balanced appearance. Vertical capitals are generally used in the title block, while vertical or inclined capitals, or capitals and lower-case letters, are used for notes.

a. *Vertical.*—The proportions, method of accomplishment, and spacing of vertical letters (and numerals) are shown in figure 17.

(1) To insure accurate alinement, light guide lines are drawn to limit the overall height of letters. Guide lines may be drawn with the T-square or with a guide-line triangle (fig. 18).

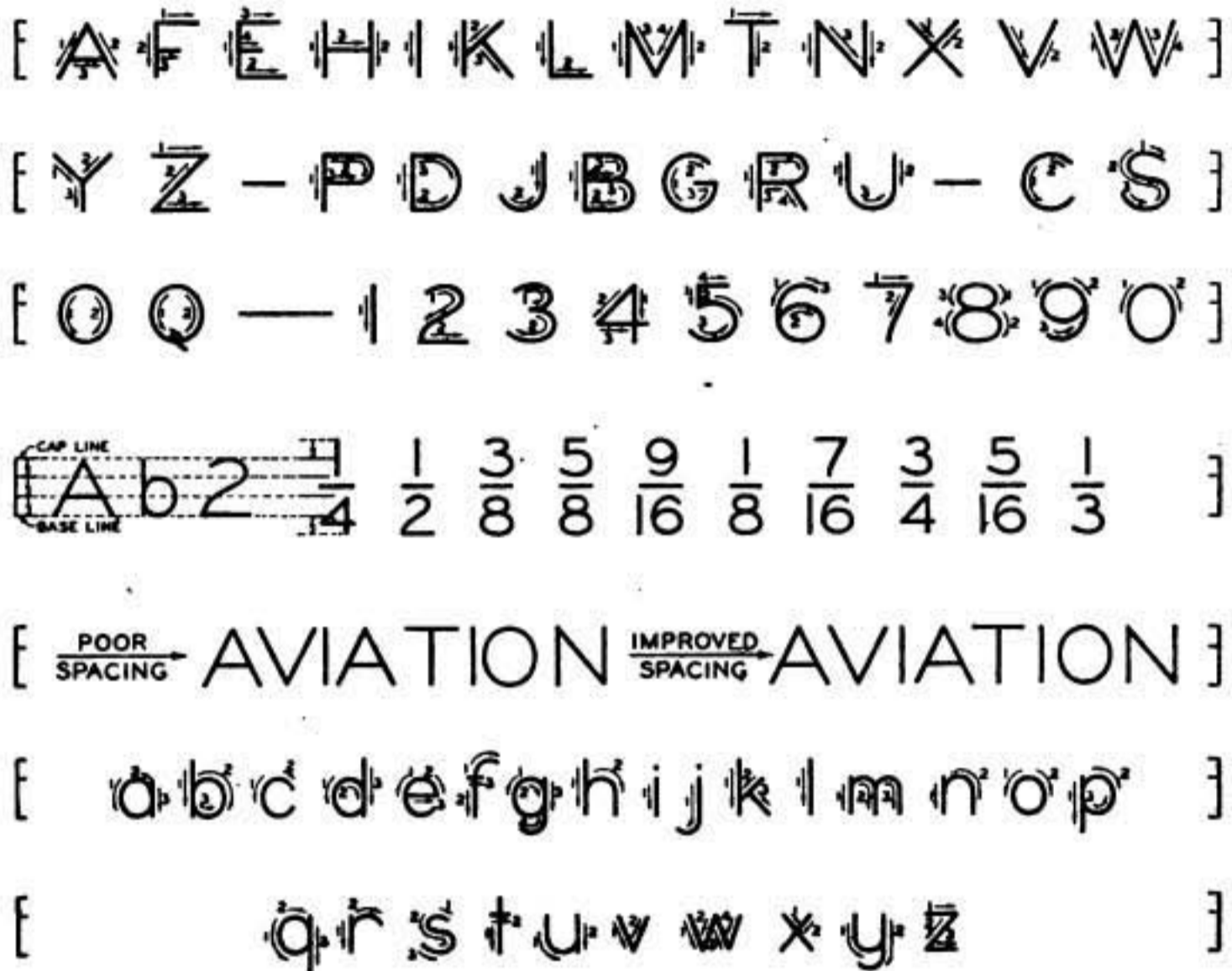

FIGURE 17.—Vertical letters and numerals.

(2) The method and order of accomplishment of the various lines of each letter are indicated by the arrows and accompanying numerals.

(3) Grouped separately are those letters which embody straight lines only, straight lines and curves, and curves only.

(4) Letters G, S, O, Q, and C are generally extended slightly above and below the spacing limits to avoid a smaller appearance with respect to other letters.

(5) Lower-case letters extend from the lower limit of the capital spacing (base line) to two-thirds the height of the capital. That portion of the lower-case letter which runs above the body of the letter is extended to the upper limit of the capital spacing (cap line); that

which runs below the body is dropped below the base line one-third the capital spacing.

(6) Numerals of fractions are two-thirds the size of full-size numerals, and extend above and below the limits of the full numerals for one-third of the height of such numerals.

b. Inclined.—Figure 19 shows the formation of inclined lettering. The proportions of width to height, stroke sequence, and direction of vertical letters apply to inclined letters. A convenient slope for inclined letters is approximately 68° . A guide line for this slope may be obtained by measuring two units on the horizontal to five units on the vertical, and then positioning and using the triangle as shown

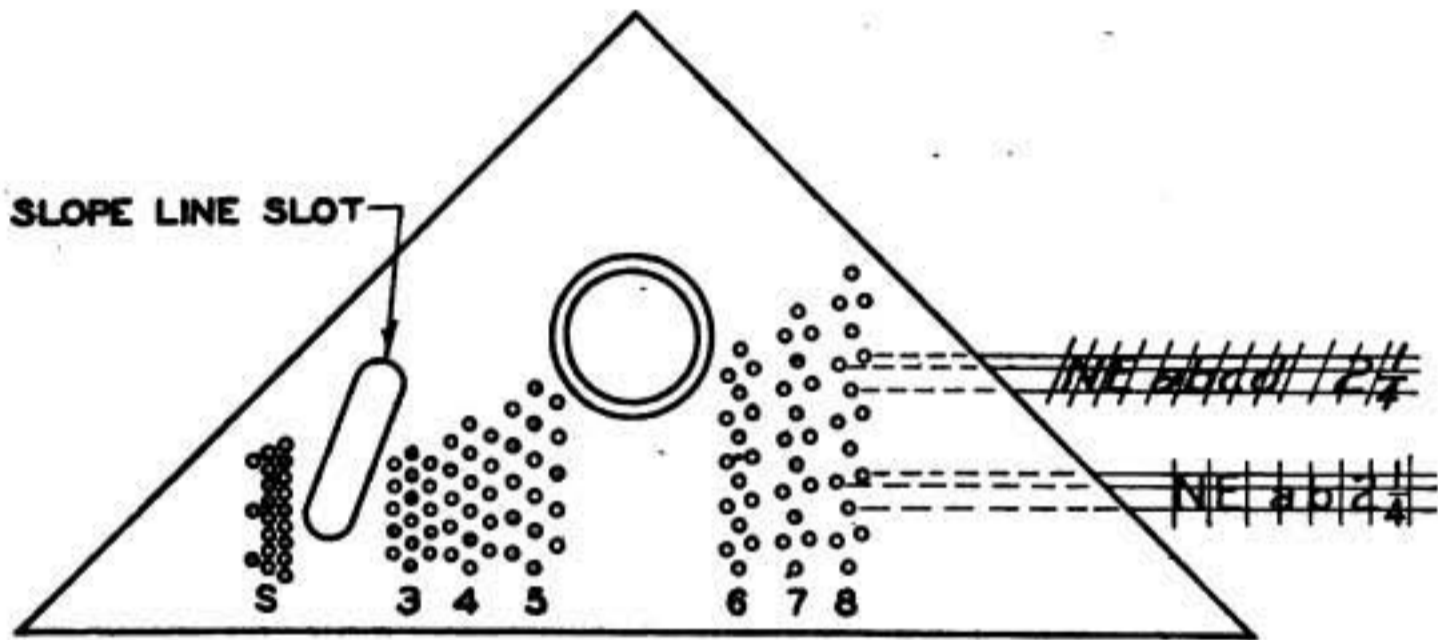

FIGURE 18.—Guide line triangle.

in figure 20. The slot of the guide line triangle (fig. 18) may also be used for slope of guide lines for inclined lettering.

c. Spacing of freehand stroke.—Next in importance to well-formed letters is the correct spacing of letters in words. By correct spacing is meant the placing of letters at such distances apart as to give the appearance of equal spacing between all letters. The shapes of letters vary; some have slanting sides, some straight sides, some rounding sides, and others projecting stems, so that only very general instructions can be given for spacing. Good judgment must be used for this. Practice with round letters, leaving equal open area between all letters. The letters of a word must be spaced so that the word will have an even appearance and there will be no unduly large white space or dark spot at any point. More space is required between two letters both of which have straight sides than between two letters, one of which has a straight side and one a round side. Less space is required between two letters with rounding sides, as "OO" or "DO", than is required in either of the above cases. The space at the bottom between the two letters "AL" should be small

so that the space between them at the top will be reduced. The letters most easily spaced are those with straight sides.

d. Guides.—Various types of guides are available as mechanical aids to lettering. The Wrico lettering guide (fig. 21) is commonly used. It consists of a template by means of which the outline of letters and numerals may be drawn. It may be used with a pencil or special Wrico pen. A separate guide and pen is required for each size of letter or numeral, except that one pen may be used with



FIGURE 19.—Inclined letters and numerals.

several of the small sizes of guides. The guides and pens are usually provided in a set containing the sizes normally used by the draftsman.

18. Lines.—*a.* Figure 22 shows various conventional line symbols and their application in drawings. The relative weights of lines as shown are considered desirable for ink drawings. Pencil drawings are generally executed with two weights of lines, medium and light. The medium line is used for those designated in figure 22 as heavy and medium; the light line is used for those designated as light.

b. The common application of lines follows:

- (1) A border line is used to frame the drawing.

(2) Outlines of parts which are visible in the particular view are shown by solid lines.

(3) An outline of a part which is invisible in the particular view is known as a hidden line and is represented by a series of short dashes

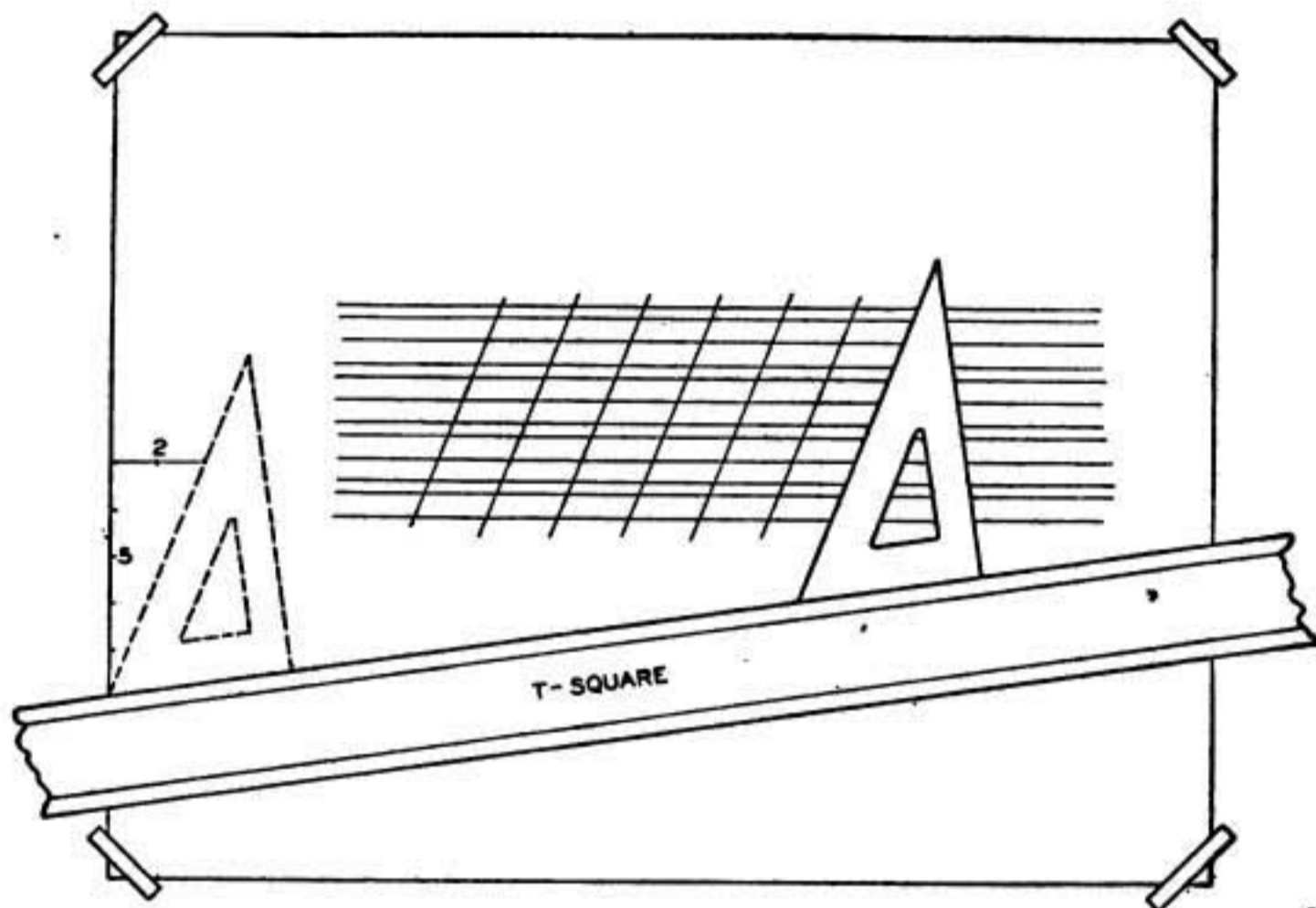

FIGURE 20.—Method of obtaining slope for inclined letters.

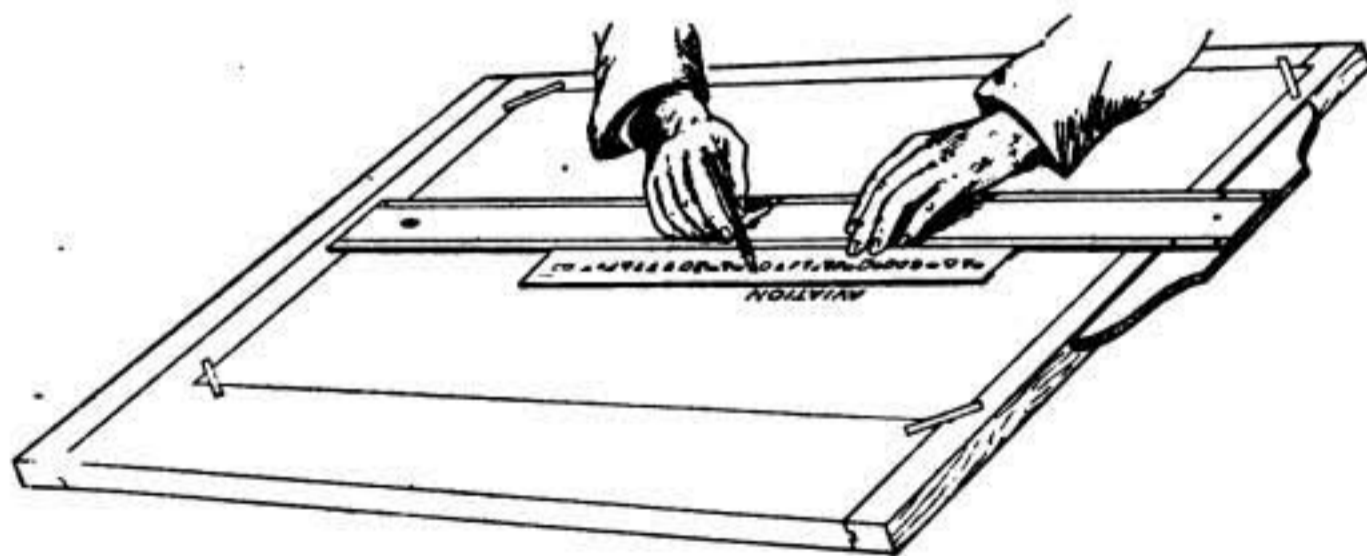

FIGURE 21.—Wrico lettering guide.

approximately $\frac{1}{8}$ inch in length. The space between dashes is approximately equal to the width of the line.

(a) A hidden line is started and stopped with a dash at the limits of the line; however, when an outline is both visible and hidden, a space is left between the visible and the hidden portions.

(b) At sharp corners of intersections of two invisible outlines, the dashes touch.

(c) A hidden line is started with a dash at the point of tangency to an arc.

(4) The short break line is drawn freehand. For long breaks a

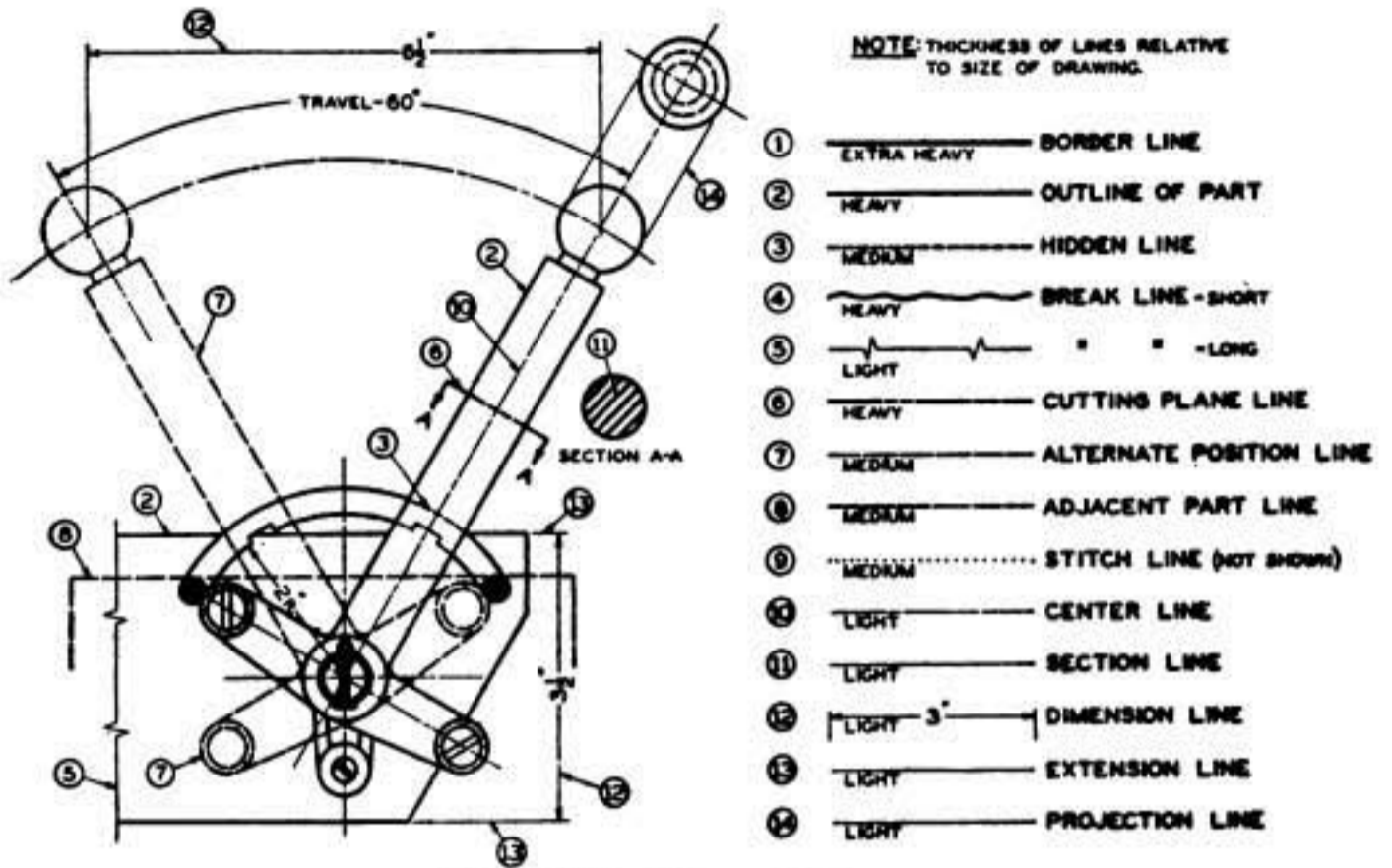

FIGURE 22.—Line symbols.

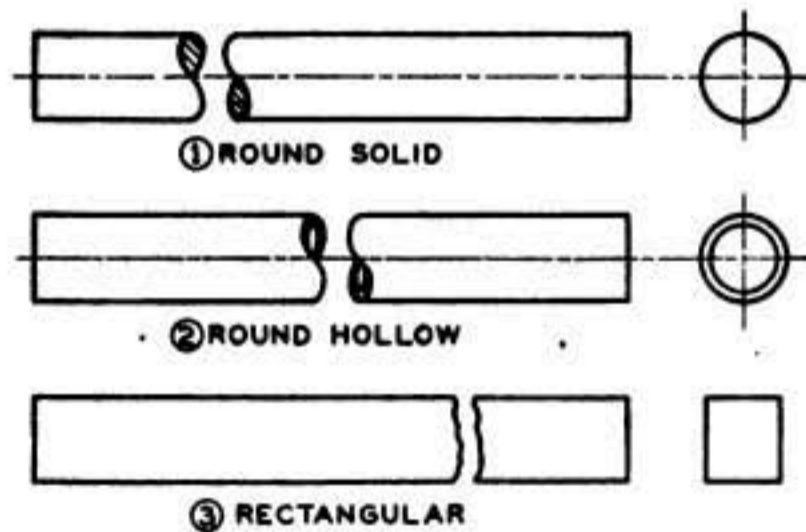

FIGURE 23.—Representation of breaks in round solid, round hollow, and rectangular shapes.



FIGURE 24.—Inking arcs, straight lines, irregular curves, and tangents.

ruled line is used with occasional freehand zigzags. Break lines are used to show—

(a) That the object continues without change in detail. The methods of indicating breaks in round solid, round hollow, and rectangular shapes are shown in figure 23.

(b) That only a portion of the entire object is represented.

(c) That a section has been revolved in place.

(5) A cutting plane line indicates where a section of a part is taken. The extremities of the line have arrowheads to show how the section is to be viewed.

(6) An alternate position line indicates limiting positions of a moving part.

(7) An adjacent part line indicates the position of the part represented.

(8) A stitch line indicates sewing.

(9) A center line indicates the center of an object or a part thereof. It is also used to locate the centers of holes or curved portions in objects.

(10) Section lines (cross-hatch lines) are used to indicate material in a sectional view (view through the part).

(11) A dimension line with its accompanying numeral indicates the distance between points on an object. Arrowheads are used at the extremities of the dimension lines.

(12) Extension lines indicate the limits of the distance indicated by the dimension line.

(13) Projection lines are used to correlate different view of an object.

c. (1) After the main center lines have been inked, solid lines are inked in the following order: circles, arcs, irregular curves, horizontal, vertical, and inclined lines. The same order is then followed for hidden lines. Finally, remaining center lines, extension, dimension, section, and border lines are accomplished.

(2) Ink lines are centered directly over pencil lines. The formation of an arc and the manner of joining it with a straight line is shown in figure 24①. In figure 24② an irregular curve is shown smoothly drawn and centered over the pencil line. Figure 24③ shows the formation of tangents. A single width of line occurs at the point of tangency.

SECTION IV

GEOMETRIC CONSTRUCTIONS

	Paragraph
General.....	19
Bisecting a line.....	20
Bisecting an arc.....	21
Bisecting an angle.....	22
Trisecting a right angle.....	23
Erecting a perpendicular to a given line from a point outside the line.....	24

	Paragraph
Erecting a perpendicular to a given line from a point in the line.....	25
Dividing a line into equal parts.....	26
Drawing a circle through three points not in a straight line.....	27
Constructing a square.....	28
Constructing a regular pentagon.....	29
Constructing a regular hexagon.....	30
Constructing a regular octagon.....	31
Drawing an arc tangent to two lines.....	32
Drawing an arc in a right angle.....	33
Drawing an ellipse.....	34

19. **General.**—*a.* In the execution of drawings the draftsman may advantageously employ applications of geometrical principles to accomplish various drawing problems rapidly and accurately. The

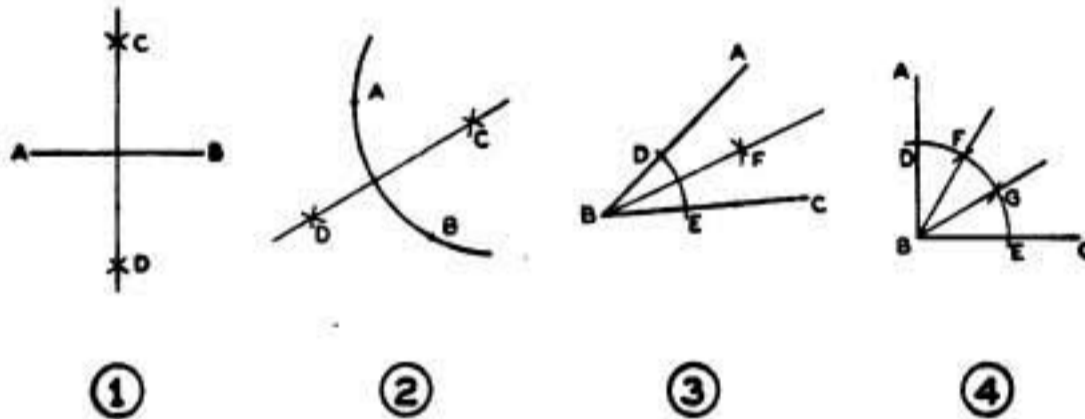

FIGURE 25.—Geometric constructions.

application of some common geometrical principles is explained in this section.

b. In the solution of a drawing by geometrical means, construction lines are drawn to locate points which determine the location of the lines of the final drawing. Construction lines should always be lightly drawn.

20. **Bisecting a line.**—Line AB (fig. 25①) is given. With A and B as centers, and a radius greater than half of AB , draw arcs above and below the given line. These arcs intersect at C and D ; a line drawn through C and D will bisect the line AB .

21. **Bisecting an arc.**—Arc AB (fig. 25②) is given. With A and B as centers, and with a radius greater than half of arc AB , draw arcs that intersect at C and D . A line drawn through the points C and D bisects the arc AB .

22. **Bisecting an angle.**—Angle ABC (fig. 25③) is given. With B as a center, draw an arc cutting the sides of the angle at D and E . With D and E as centers, and with a radius greater than half of arc DE , draw arcs intersecting at F . A line drawn from B through the point F bisects the angle ABC .

23. **Trisecting a right angle.**—Right angle ABC (fig. 25④) is given. With B as a center, draw an arc cutting the sides of the angle

at D and E . With D and E as centers, and with the same radius, draw arcs intersecting arc DE at F and G . Lines drawn from B through points F and G trisect the angle ABC .

24. Erecting a perpendicular to a given line from a point outside the line.—Point P and line AB (fig. 26①) are given. With P as a center, and with a radius greater than the distance from P to AB , draw an arc cutting the line AB at C and D . With C and D as centers, and with a radius either greater or less than the distance from P to C or D , draw arcs intersecting at E or F . A line drawn through E and P or F and P will be perpendicular to the line AB .

25. Erecting a perpendicular to a given line from a point in the line.—Point P and line AB (fig. 26②) are given. With P as

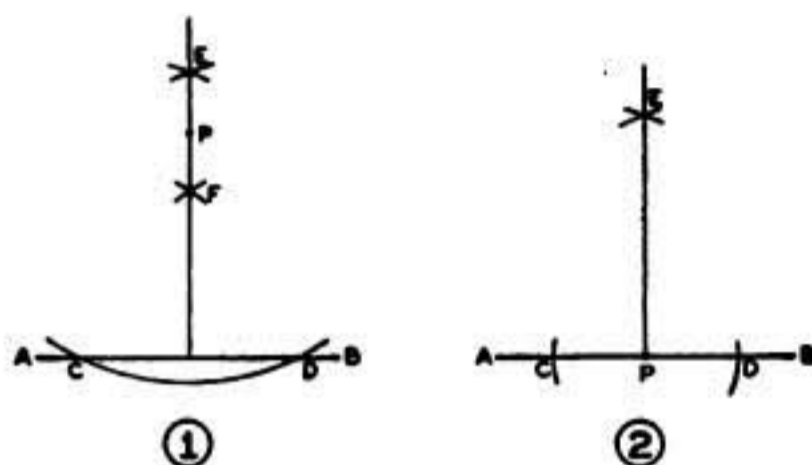

FIGURE 26.—Geometric constructions.

a center, draw arcs cutting the line AB at C and D . With C and D as centers, and with a radius greater than half of CD , draw arcs intersecting at E . A line drawn through E to point P is perpendicular to the given line AB . If the point P is near the end of the line, the line is extended and the same procedure followed.

26. Dividing a line into equal parts.—The given line AB (fig. 27①) is to be divided into seven equal parts. Starting at end B of the given line AB , mark off seven equal divisions at any convenient angle ABC to the given line. Connect the last mark C of the divisions and the opposite end of the given line A . Draw parallels to the line AC through each of the division marks, thus obtaining the equal divisions on the given line.

27. Drawing a circle through three points not in a straight line.—*a.* The three points A , B , and C (fig. 27②) are given. Join points A and B , and B and C . Erect perpendicular bisectors to AB and BC , intersecting at O . The radius of the required circle is OA , or OB , or OC .

b. To find the center of a circle or arc, assume three points on the circle or arc and proceed as above.

28. Constructing a square.—Line AB (fig. 28①) is given. With A as a center, and with a radius R equal to AB , draw the arc EB . Erect a perpendicular at point A . With C and B as centers, and with a radius equal to AB , draw arcs intersecting at D . Draw CD and BD to complete the square.

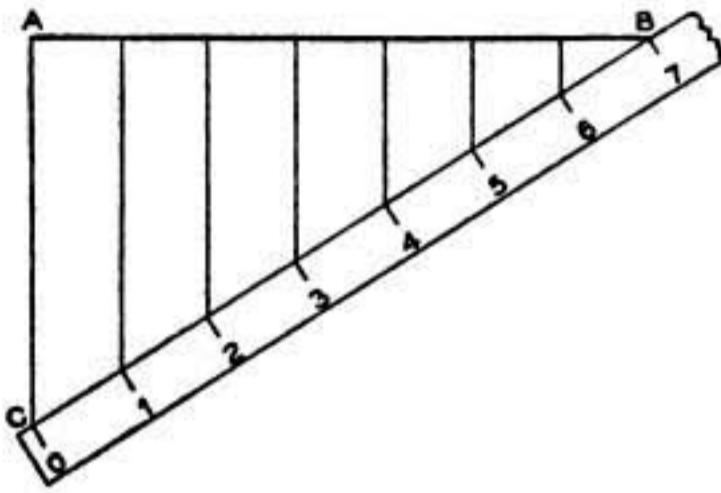

①

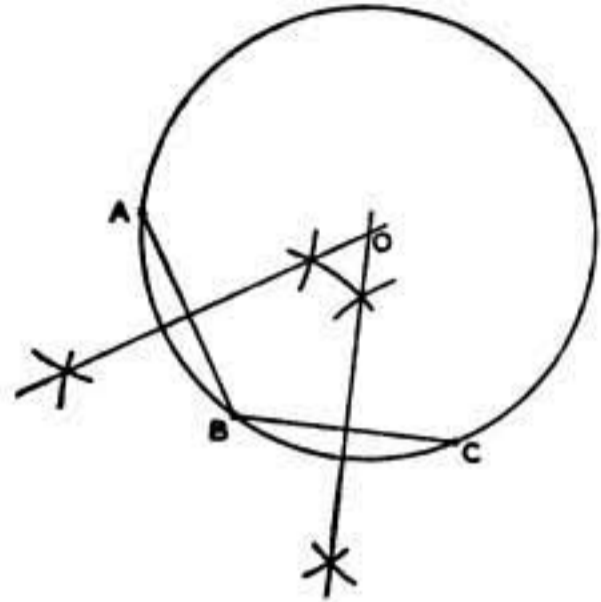

②

FIGURE 27.—Geometric constructions.

29. Constructing a regular pentagon.—The circle (fig. 28②) with center O is given. Draw a diameter AB , and a radius OC perpendicular to it. Bisect OB , and with point D as a center, and with a radius DC , draw the arc CE . With C as a center, and with a radius CE , draw the arc EF . CF is one side of the pentagon. With the same radius, mark off the remaining three points and connect them.

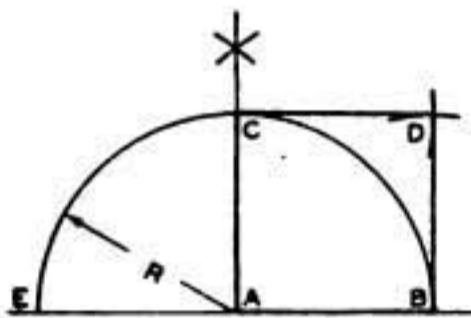

①

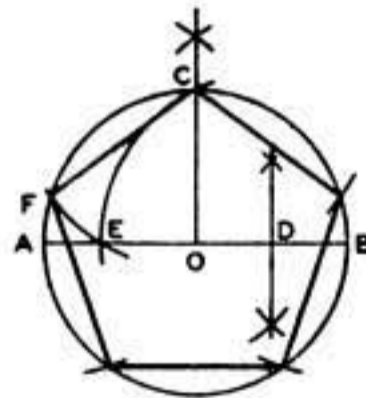

②

FIGURE 28.—Geometric constructions.

30. Constructing a regular hexagon.—*a.* The distance AB (fig. 29①) across corners is given. Draw a circle with AB as a diameter. With A and B as centers, and with a radius equal to one-half of AB , draw arcs cutting the circle at C , E , D , and F , and connect these points.

b. The distance between parallel sides (fig. 29②) is given. Draw

a circle having a diameter equal to the distance between the parallel sides. With the T-square and 30° to 60° triangle, draw lines tangent to the circle at *A, B, C, D, E,* and *F*.

31. Constructing a regular octagon.—The square *ABCD* (fig. 29③) is given. Draw the diagonals of the square. With the cor-

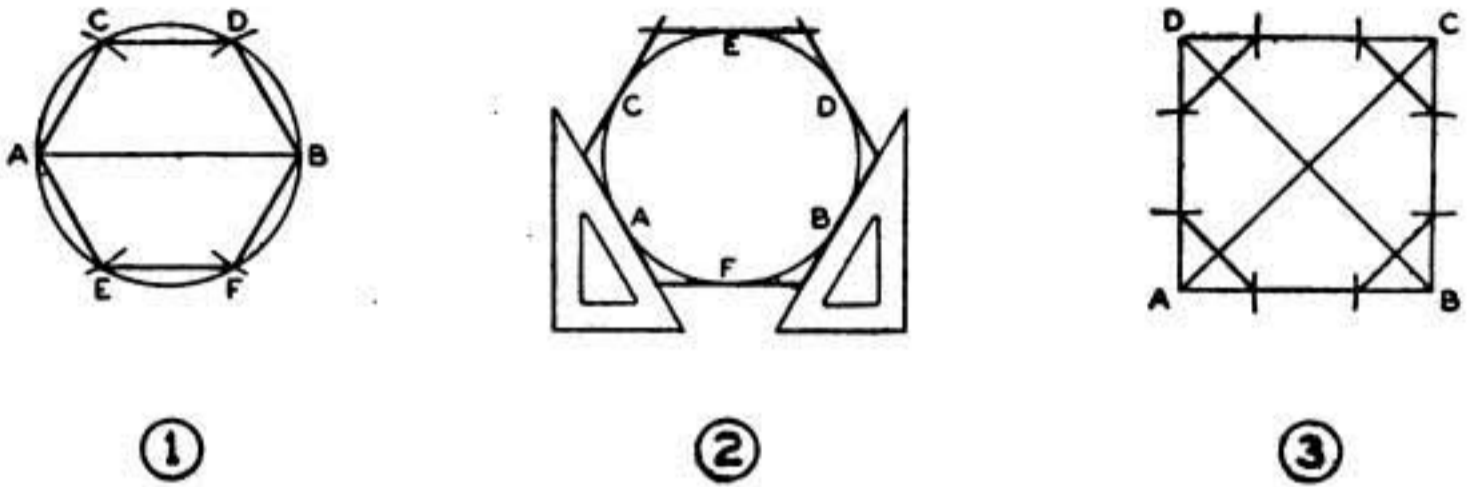

FIGURE 29.—Geometric constructions.

ners as centers, and with a radius of half a diagonal, draw arcs cutting the sides of the square and connect these points.

32. Drawing an arc tangent to two lines.—Two lines, *AB* and *CD*, and a radius *R* (fig. 30①) are given. Draw lines parallel to *AB* and *CD* at a distance *R* from them. The intersection of these lines will be the center of the required arc *EF*. Locate the points of

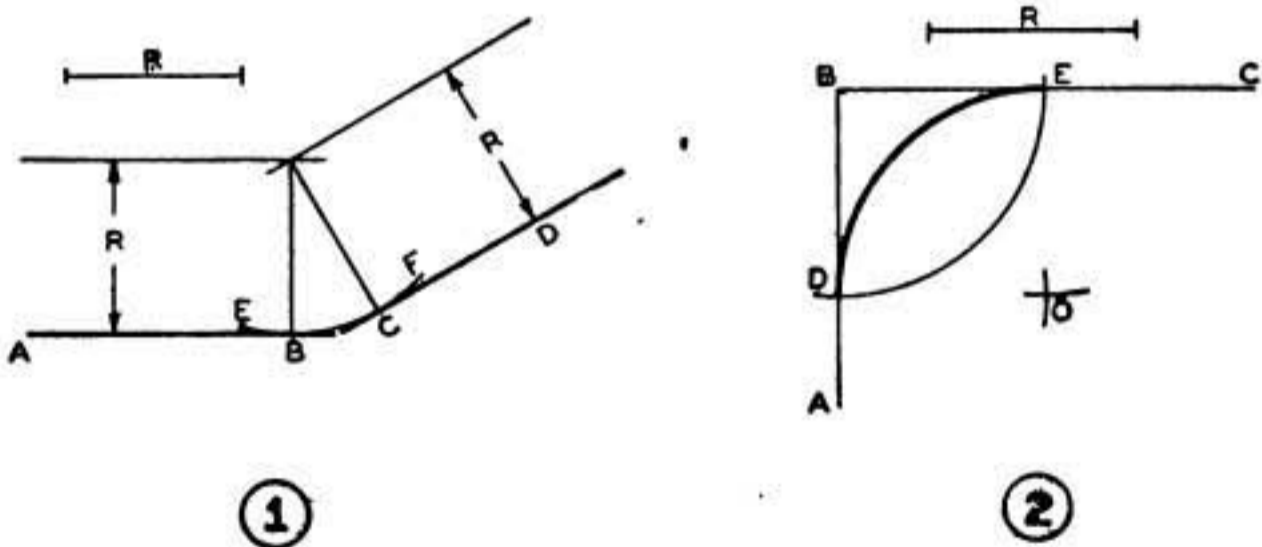

FIGURE 30.—Geometric constructions.

tangency by drawing lines through the center of the arc perpendicular to the tangent lines.

33. Drawing an arc in a right angle.—The right angle *ABC*, and the radius *R* (fig. 30②) are given. With *B* as a center and with a radius *R*, draw an arc intersecting the sides at *D* and *E*. With *D* and *E* as centers, and with the same radius, draw arcs intersecting at *O*. With *O* as a center, and with the same radius, draw arc *DE*. This arc will be tangent to the lines *AB* and *BC*.

34. Drawing an ellipse.—The major diameter AB and the minor diameter CD (fig. 31) are given. With the intersection (O) of these diameters as a center, draw circles on the major and minor diameters. Draw a number of radial lines OP , OQ , etc., cutting the large circle at P and Q and the small circle at P' and Q' . From P' and Q' draw lines parallel to the major diameter (AB), and from P and Q draw lines parallel to the minor axis (CD). The points of inter-

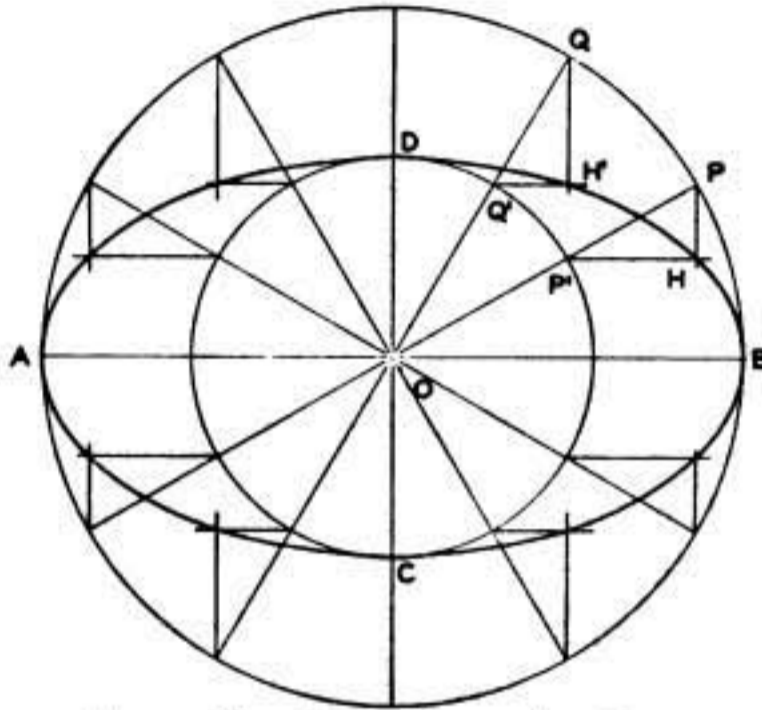

FIGURE 31.—Geometric constructions.

section of these lines, H and H' , are two points on the ellipse. Find as many points as necessary, and through them draw the curve.

SECTION V

ORTHOGRAPHIC PROJECTION

	Paragraph
General.....	35
Detailed description.....	36
Arrangement of views.....	37

35. General.—*a.* The representation of an object as seen by an observer (pictorial view) is considered inadequate for shop use, because the true shapes of some surfaces are not revealed and dimensions are difficult to locate. These difficulties are overcome through the process of orthographic projection.

b. Orthographic projection is the process of projecting accurate outlines of views of an object and properly arranging them. This method may best be explained through a process of tracing views of an object on the sides of a transparent box, and then manipulating the sides of the box (and consequently the traced views) in a mechanical method simulating the theory controlling the location and arrangement of the views necessary to present a picture of the object.

36. Detailed description.—*a.* (1) To obtain the front view of an object, imagine a transparent sheet, called the plane of projection (fig. 32①), located vertically in front of the object. By sighting perpendicularly through the plane of projection, the lines of sight will serve to guide the transfer of points of intersection, and lines representing the outline of the object, from the object to the plane of projection. Sighting at right angles, or perpendicularly, to the plane of projection

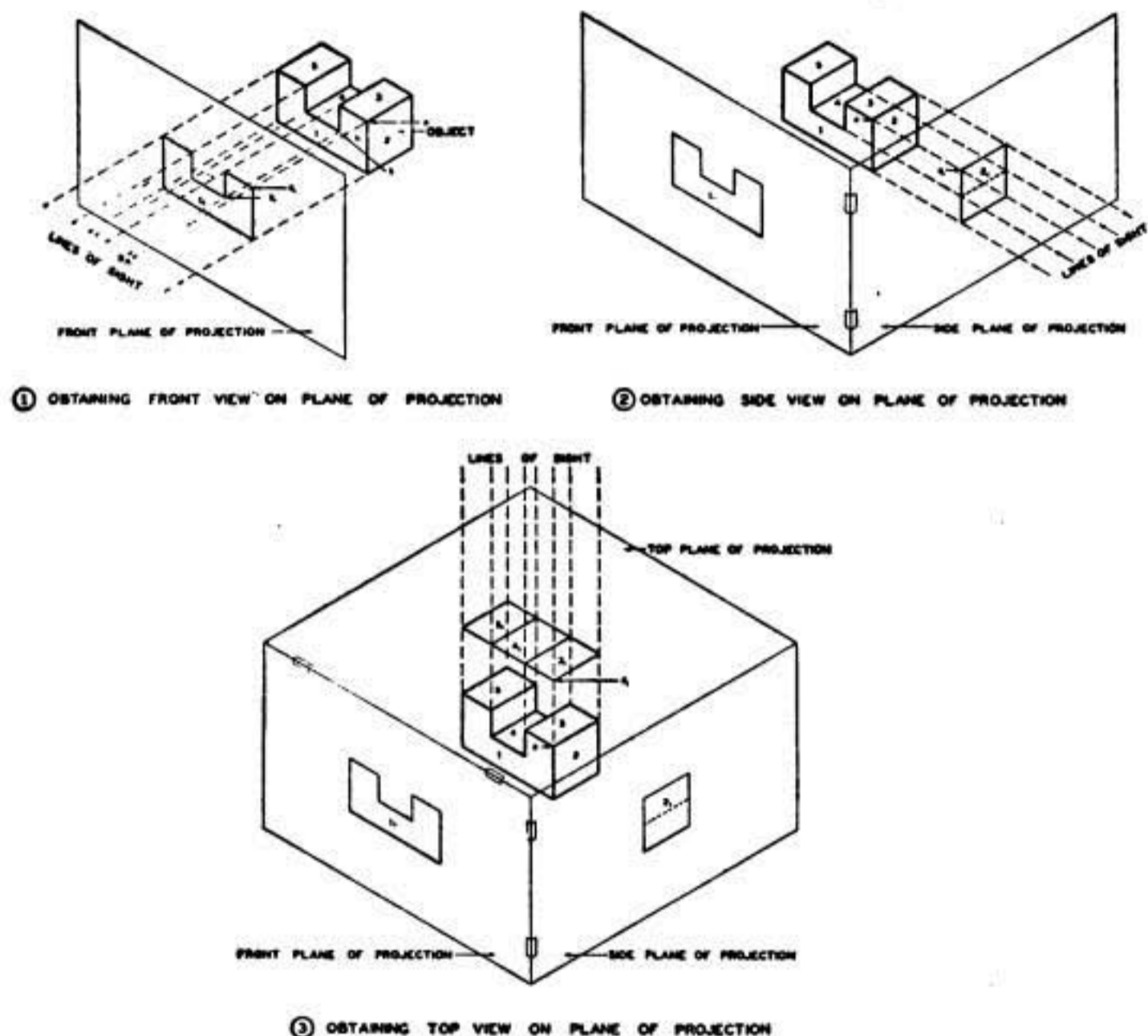

FIGURE 32.—Method of obtaining orthographic projection.

is essential, as this is the factor which determines the accuracy of projection. Thus, the eye moves successively over the outline of the object to project the various points. As shown in figure 32, the line of sight originating at *A* passes through the plane of projection to meet the object at *a*. The point *a*₁ where the line of sight *A* intersects the plane of projection is the location of the projected point *a*. In like manner, the line of sight *B* will guide the projection of point *b* on the object to point *b*₁ on the plane of projection. By repeating this operation at any number of points, the entire view may be transferred to the plane of projection. The projection thus obtained is an exact

outline of the front view of the object, and may be clearly and accurately dimensioned.

(2) To obtain a side view of the object, join a second plane of projection at right angles to the first plane as shown in figure 32(2). Move

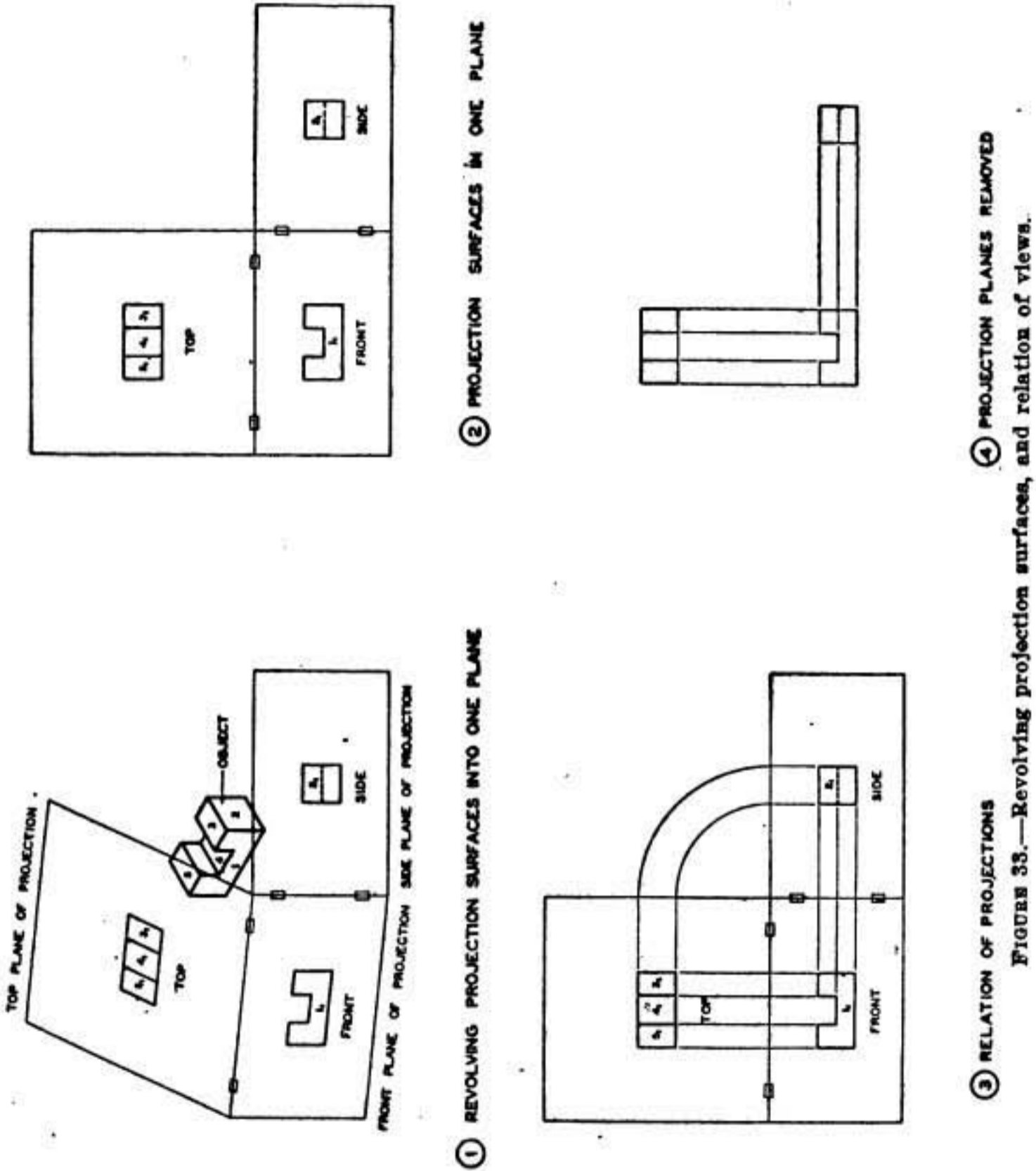

FIGURE 33.—Revolving projection surfaces, and relation of views.

the lines of sight to a position perpendicular to the second or side plane of projection. If the procedure outlined for the front plane of projection is now repeated for the side plane of projection, the result will be the orthographic projection of the right side of the object. Edges

and surfaces which are invisible in the plane of projection are indicated by the conventional symbol for hidden lines.

(3) To obtain a top view of the object, join a third plane of projection horizontally above and at right angles to the front and side planes (fig. 32③). Move the lines of sight to a position perpendicular to the third or top plane. The lines of sight will now be parallel to the front and side planes. Repeat the procedure heretofore outlined to obtain the orthographic projection of the top of the object.

b. If the side and top planes are imagined to be hinged to the front plane and are revolved away from the object (fig. 33①) until they coincide with the front plane, the three views appear on the same plane of projection (fig. 33②). Figure 33③ illustrates the relationship of the three views; in figure 33④ the views are shown, as on a drawing, with the projection planes removed.

c. Occasionally a cylindrical part may be shown in only one view (fig. 34) if the required diameters and other dimensions are all indicated

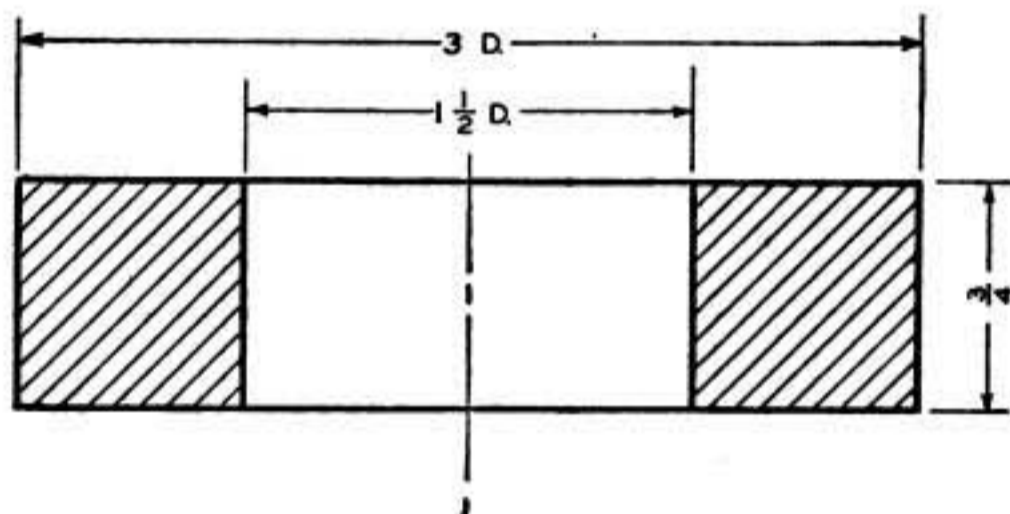

FIGURE 34.—Single-view drawing.

thereon. Some objects, such as a bushing (fig. 35), require only two views, as the side view duplicates the front view. In figure 36, the objects pictorially represented have front and top views which are similar, demonstrating the need of a third view for a complete understanding of the shape of the objects.

37. Arrangement of views.—*a.* Frequently more than three views of an object are necessary. Figure 37 shows the relative positions of the six principal views of an object. A bottom view is used instead of a top view when the shapes or operations to be shown are on the under side of the part. For example, for an object such as a punch

and die, the arrangement of views would be as shown in figure 38, with the view of the bottom of the punch placed in the position of the bottom view, and the top of the die in the position of the top view. If space

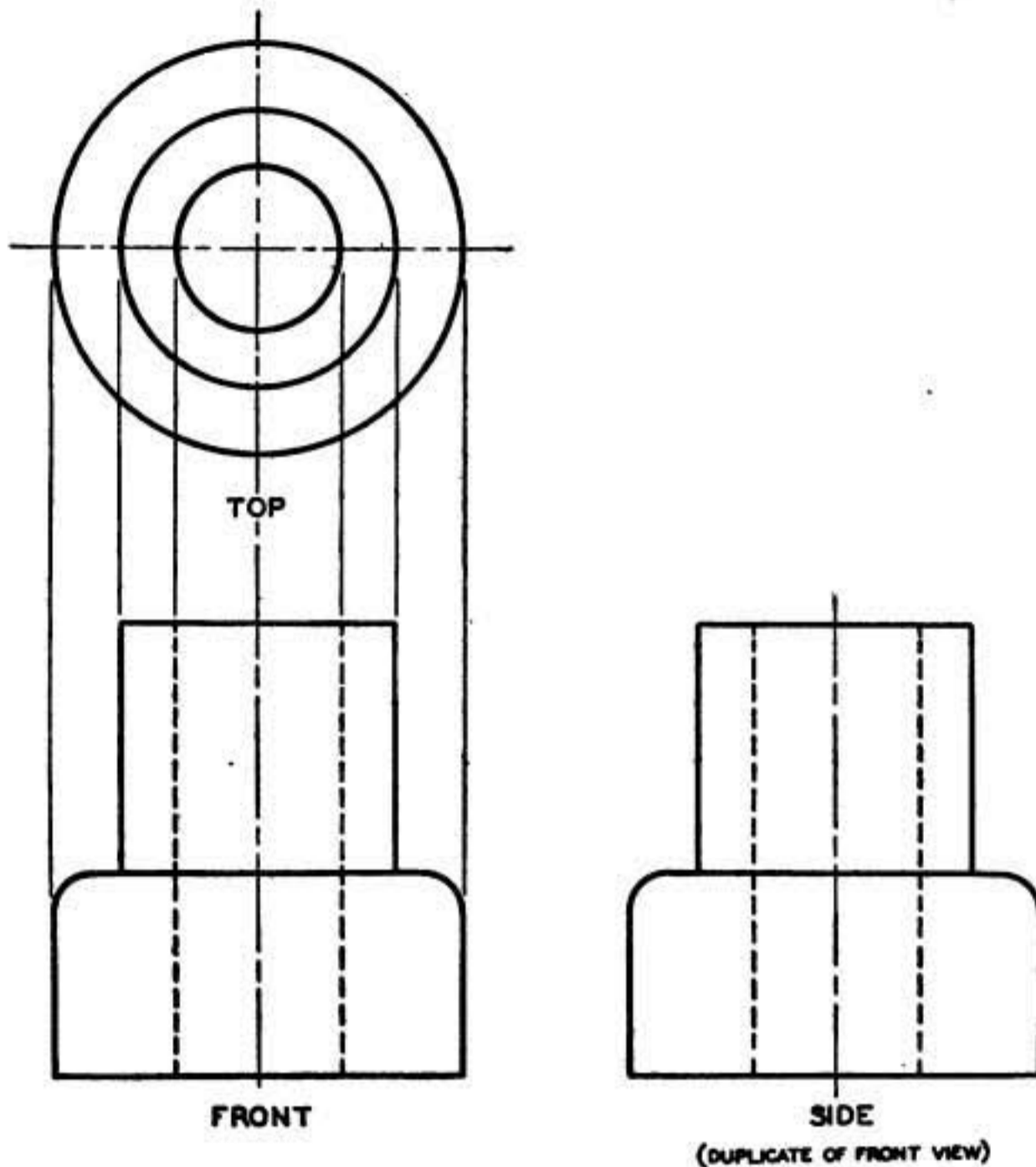

FIGURE 35.—Two-view drawing.

does permit, the bottom view may be placed to the right of the top view. The side view may also be placed across from the top view (fig. 39) when space does not permit location in the usual position.

b. Views of an object on a plane not parallel to any of the usual views are called auxiliary views. When an object has an inclined

surface, the true shape and size of such surface is not shown in any of the regular views, and an auxiliary view is necessary. This is especially true where the inclined surface is of irregular outline. Figure 40① shows a pictorial representation of a block with an inclined surface. The usual three views are shown at ②, and a front

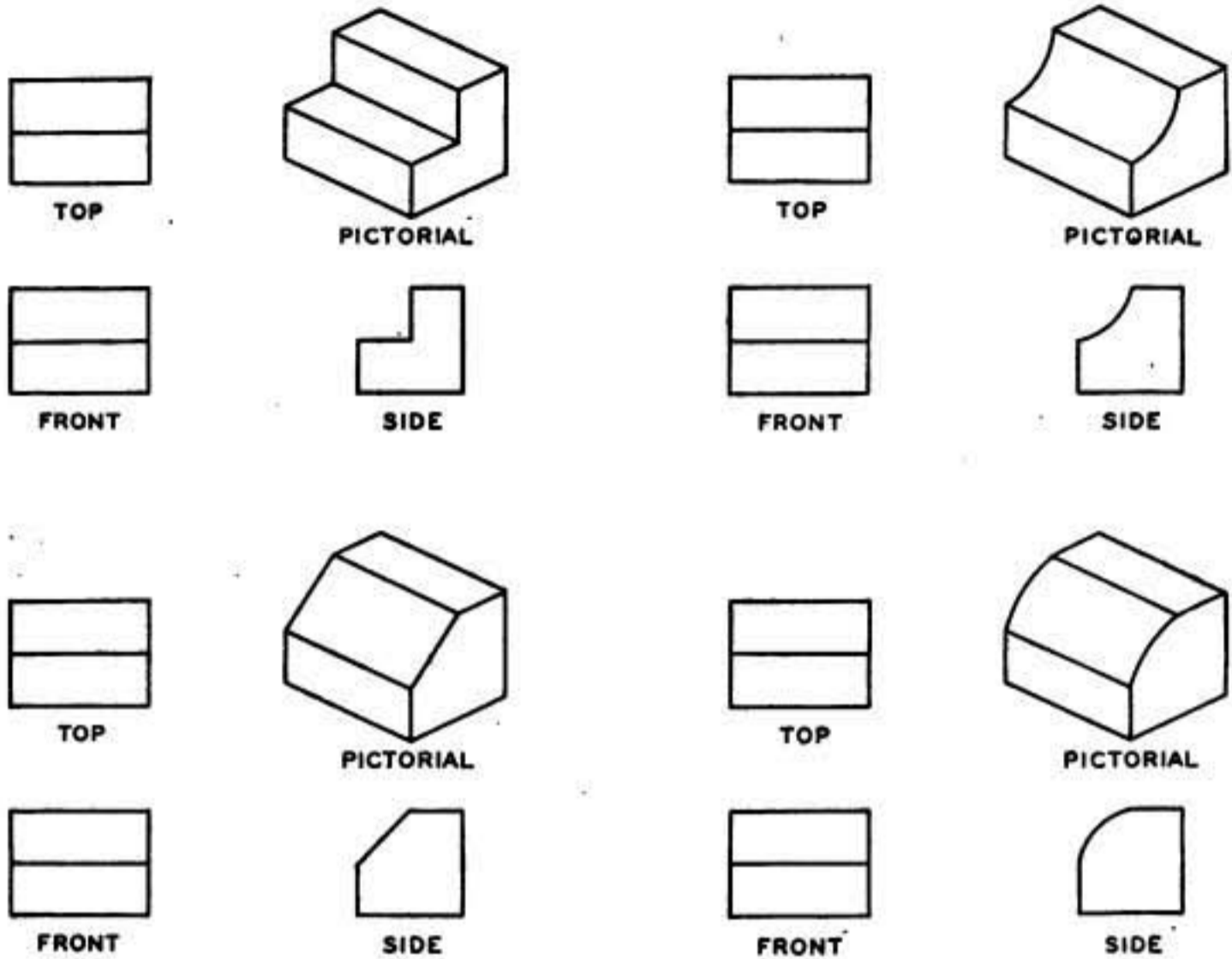

FIGURE 36.—Necessity of third view.

and auxiliary view at ③. In the regular orthographic projection, none of the three views shows the true outline of the inclined surface. With the front and auxiliary views, the inclined plane is shown with its true inclination and outline. For an understandable drawing of the object shown in figure 41①, only a front view ②, a partial top view ③, and a partial auxiliary view ④ is required.

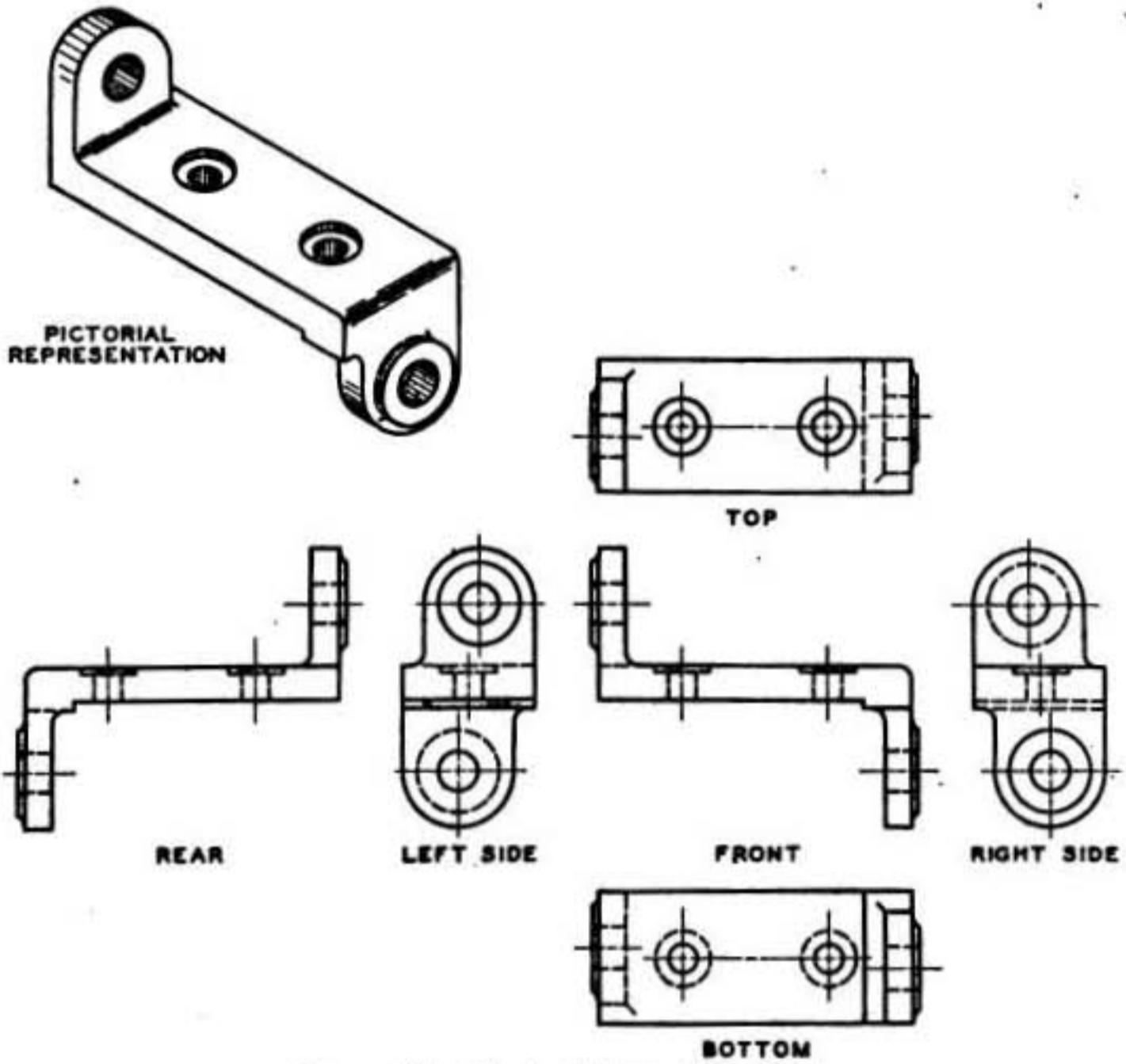

FIGURE 37.—Principal views of an object.

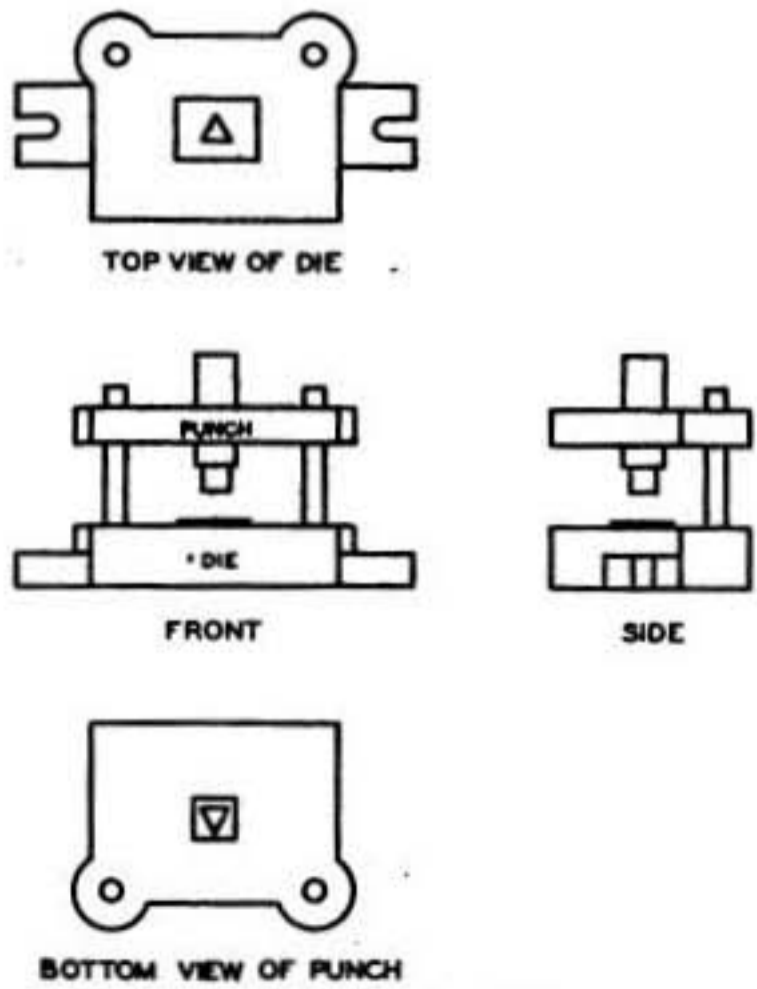

FIGURE 38.—Choice of views.

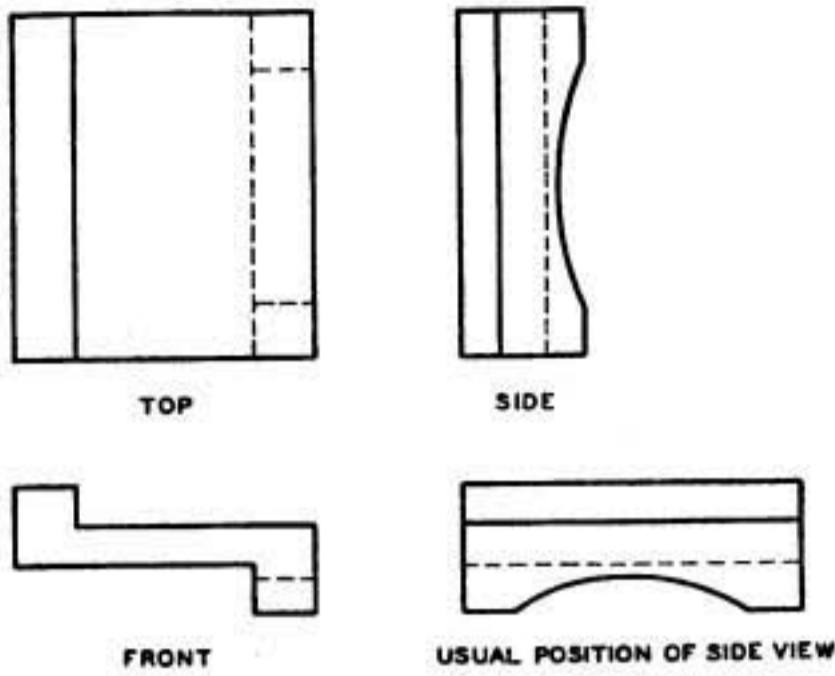
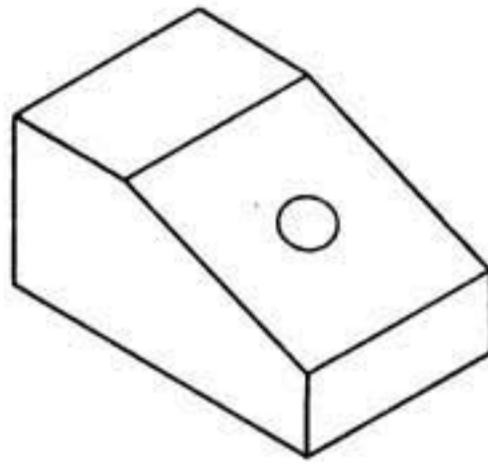
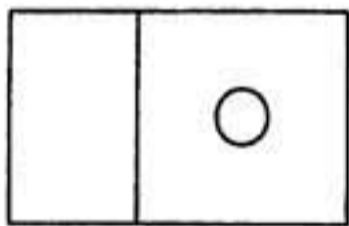

FIGURE 39.—Arrangement of side view in limited space.



PICTORIAL
①



TOP

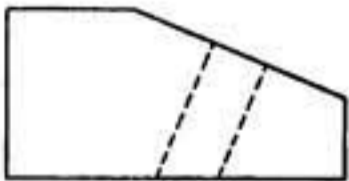

FRONT

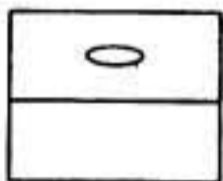

SIDE

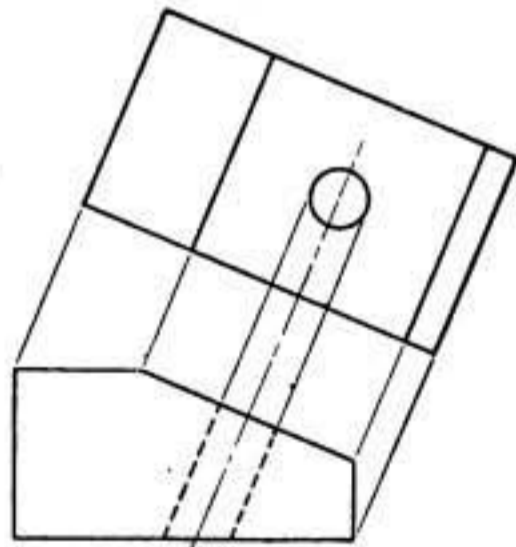

FRONT AND AUXILIARY VIEWS

②

③

FIGURE 40.—Front, top, side, and auxiliary views.

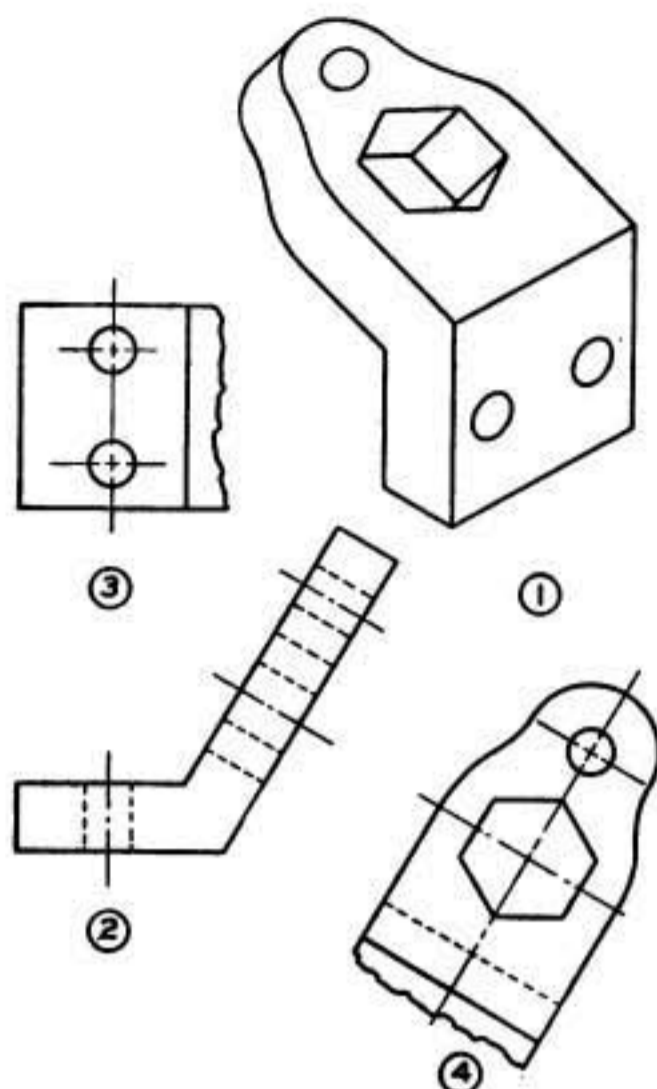

FIGURE 41.—Front, top, and auxiliary views.

SECTION VI

PICTORIAL DRAWING

	Paragraph
General.....	38
Perspective drawing.....	39
Isometric drawing.....	40
Oblique drawing.....	41
Cabinet drawing.....	42

38. General.—Pictorial drawings are seldom used by themselves as working drawings, but are generally used as illustrations where details of orthographic projection would not be easily understood. They have the advantage of requiring less training of the imagination to visualize a complicated object, and, in some instances, require less time to draw. Designers find it necessary and many workmen find it helpful to be able to present their ideas to others either with pictorial sketches or with one of the various styles of pictorial mechanical drawings. These drawings have the disadvantages of not always showing the true lengths or shapes of objects and of not showing hidden lines. In some types of pictorial drawing, a distorted appearance is given to the object drawn. A comparison of the types of pictorial drawings is shown in figure 42.

39. Perspective drawing.—*a.* A perspective drawing represents an object on a plane surface as it appears to the eye, and affords a better pictorial effect than other types of drawings.

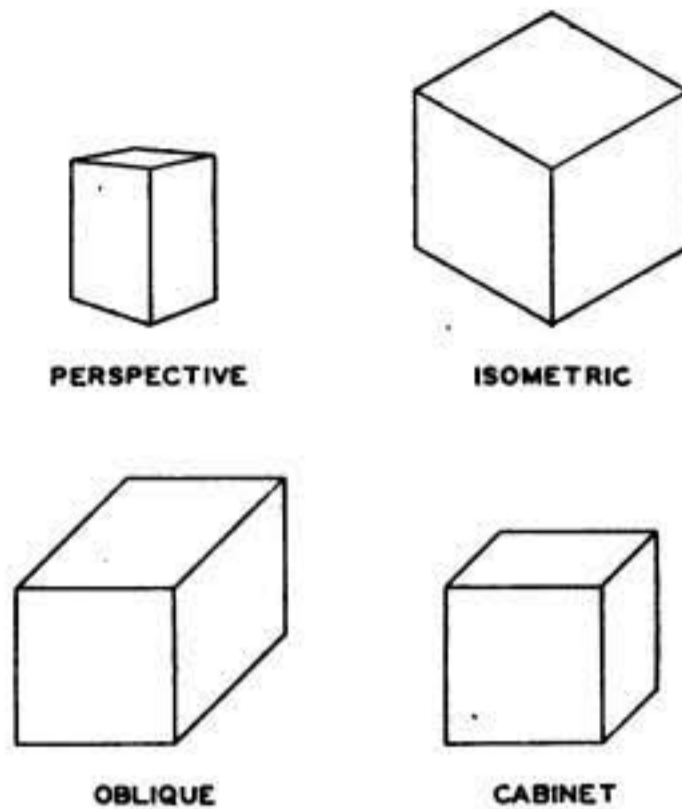

FIGURE 42.—Comparison of types of pictorial drawings.

b. (1) One-point, or parallel perspective, drawings (fig. 43①) are those in which the object to be drawn is viewed in such a manner

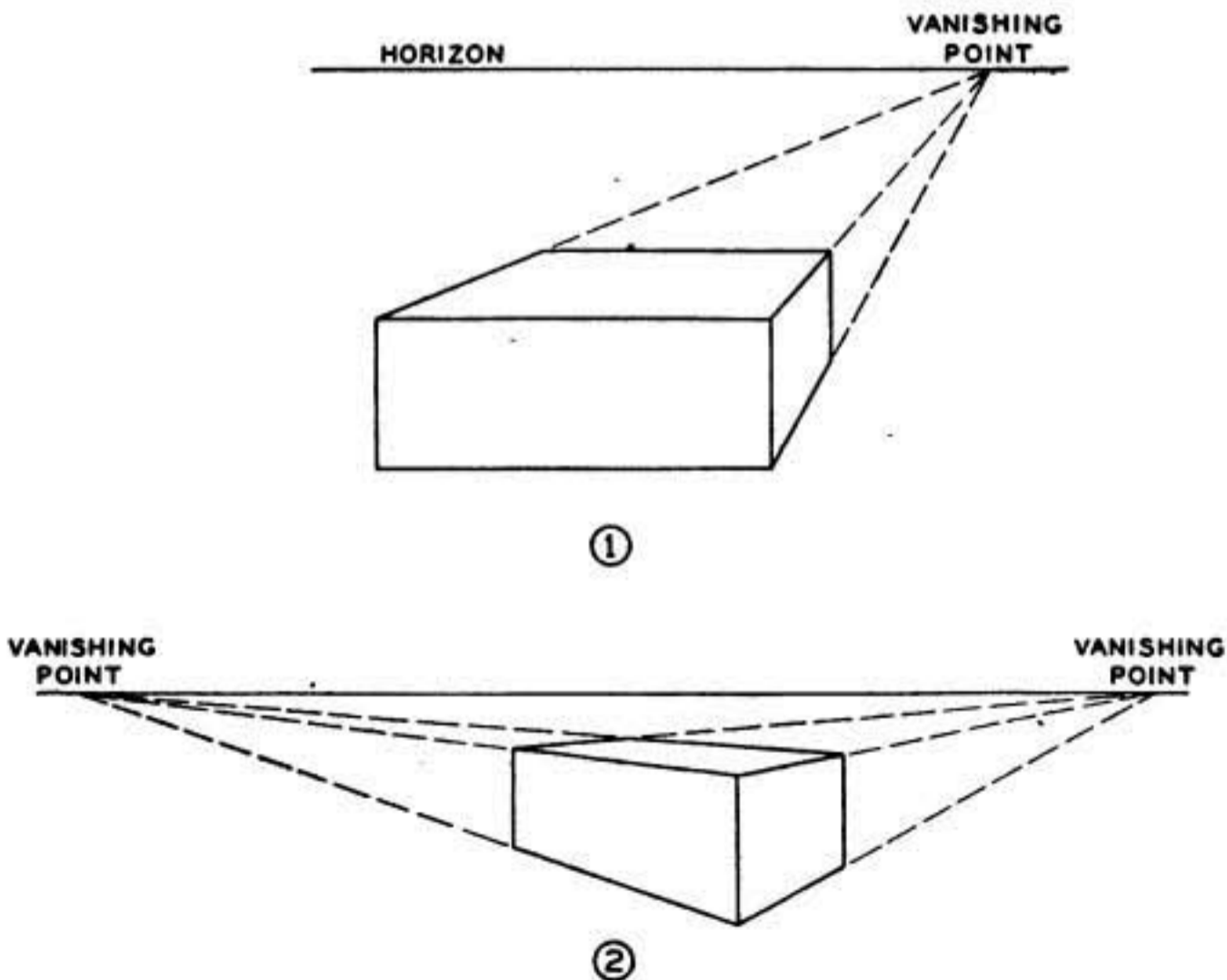

FIGURE 43.—Perspective drawings.

that one face is parallel to the front plane. In this style of perspective the horizontal lines of the front plane remain parallel, but the lines of all planes perpendicular to it meet at one point. The point at which the converging lines of a perspective drawing meet is called the vanishing point.

(2) Two-point, or angular perspective, drawings (fig. 43②) are those in which the object to be drawn is viewed from an angle and in which the two sets of horizontal lines meet at respective points on the horizon.

40. Isometric drawing.—*a.* If a cube is tilted so that its front view appears as shown in figure 44①, in which the edges AB , AC ,

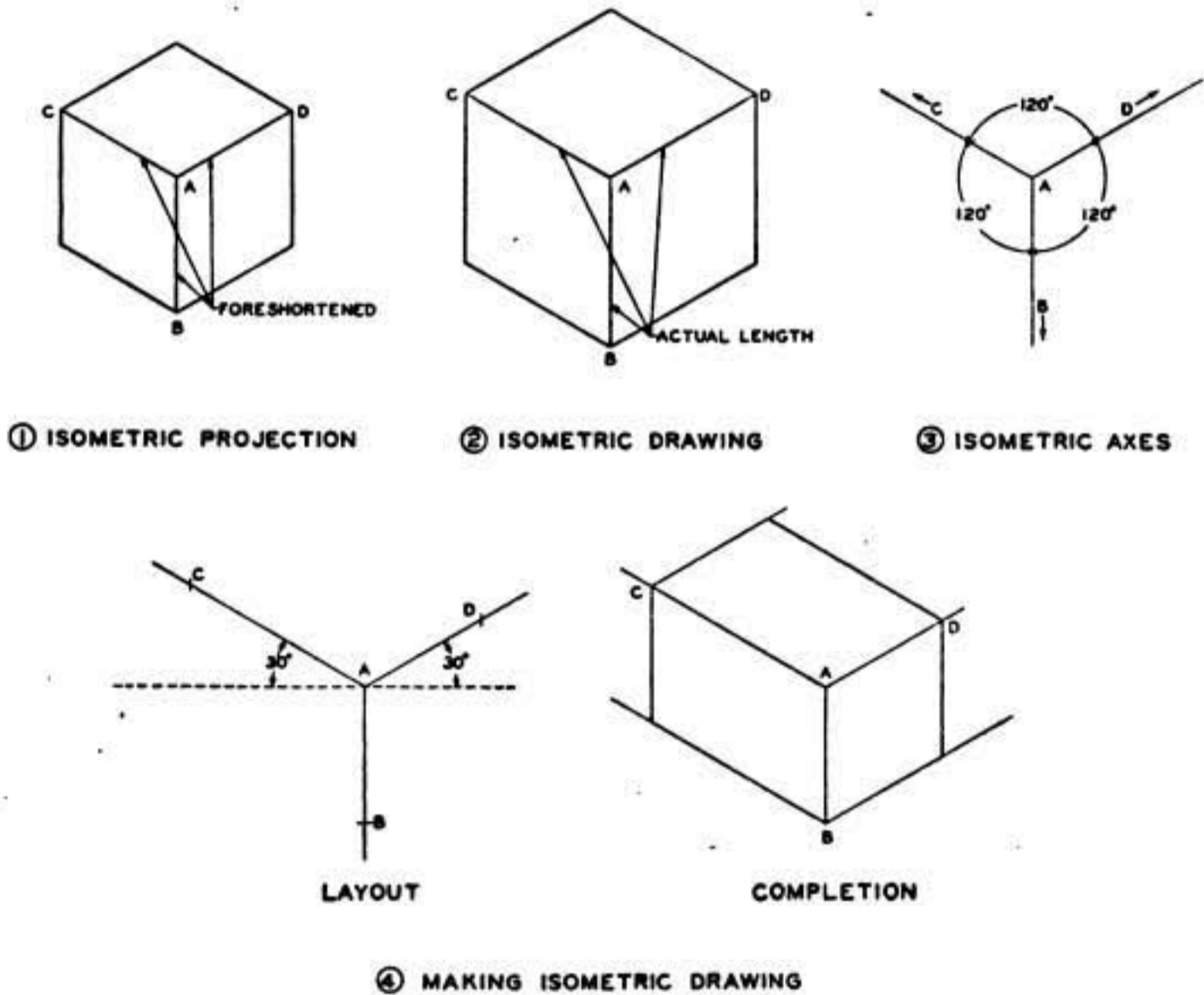

FIGURE 44.—Isometric projection and drawing.

and AD are equally foreshortened, an isometric projection is represented. An isometric drawing (fig. 44②) shows the cube in the same position with the actual length of edges shown. The isometric axes (fig. 44③) are the three lines of the front corner of the cube, and make angles of 120° with one another.

b. In learning to make an isometric drawing it is best to start with some simple object such as a rectangular block. Lay off three light lines of indefinite length representing the isometric axes (fig. 44④).

Mark off on the axes the length, breadth, and thickness of the block. The isometric drawing is then completed by drawing, through the points marked off, lines parallel to the isometric axes.

c. (1) Invisible lines are not shown in isometric drawings unless they are necessary for the understanding of the drawing.

(2) A nonisometric line is one which is not parallel to any of the isometric axes and does not show its true length in an isometric drawing. To make an isometric drawing of an object having nonisometric lines, as line AC (fig. 45①), drop a perpendicular from C on the front

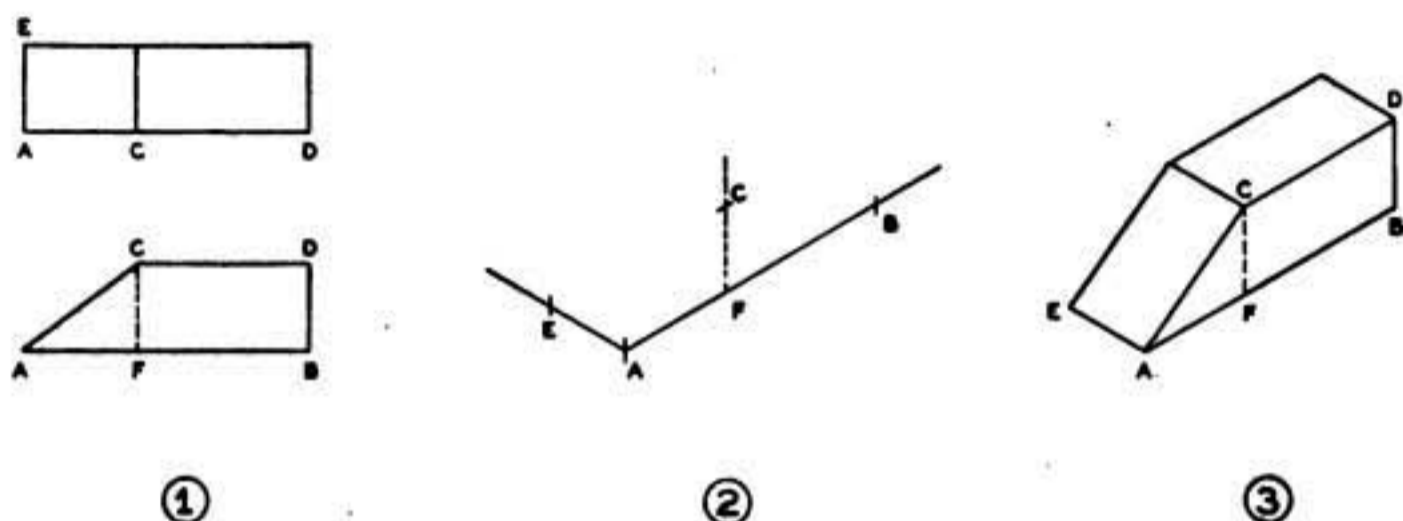

FIGURE 45.—Isometric drawing with nonisometric lines.

view, giving the line CF . Draw the isometric axes AE and AB (fig. 45②) the same length as their corresponding length in the front and top views. Lay off AF on lines AB equal to its corresponding length on the front view. At F construct a vertical line FC equal to FC in the front view. Connect the points A and C which will give the nonisometric line AC in an isometric view (fig. 45③). The remaining lines are then drawn and the block completed.

(3) Angles in isometric drawings do not show in their true size, and therefore cannot be measured in degrees.

(4) Circles are drawn as ellipses in isometric drawings. Figure 46① shows a cube with an isometric circle drawn in each of its visible planes or faces. The first step in drawing an ellipse representing an isometric circle is to draw the isometric square $ABCD$ (fig. 46②), having sides equal to the diameter of the circle desired. Perpendiculars are erected at $E, F, G,$ and H , the midpoints of the four sides of the isometric square. These perpendiculars intersect at J and K . With A and C as centers, and with a radius equal to AH or CF , construct arcs HG and FE , respectively. With J and K as centers, and with a radius JH or KF , construct arcs EH and GF , respectively, thus completing the isometric circle. This method of constructing an ellipse is known as the four-center approximate method.

(5) Isometric arcs (fig. 46③) are drawn as follows:

(a) The true radius is measured from the intersection of the two lines forming the sides of the isometric square, and perpendiculars are erected at the points thus located; the intersection of these perpendiculars gives the center of the required isometric arc.

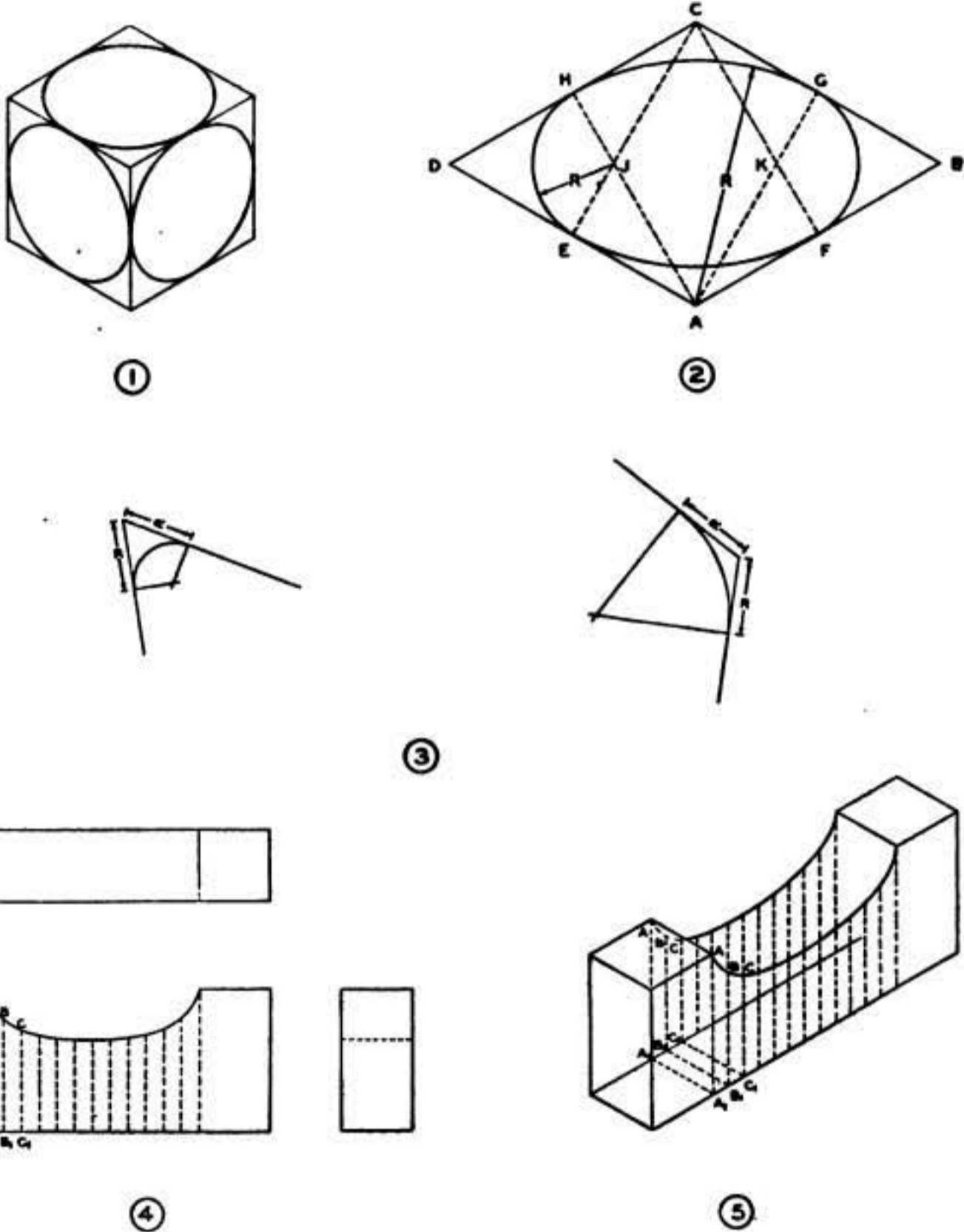

FIGURE 46.—Isometric circles, arcs, and curves.

(b) The radius of the isometric arc is the length of the perpendicular to the point of intersection.

(6) Isometric curves other than circles are drawn by first locating a number of points on an orthographic projection (fig. 46④). These points are then transferred to the isometric drawing (fig. 46⑤), and the curve drawn through these points.

41. Oblique drawing.—*a.* When an object is placed with one face parallel to the plane of projection and is projected by oblique lines to the plane, an oblique view results. This differs from orthographic and isometric projections in which the projectors are perpendicular to the plane of projection. The angle which the oblique lines make with the plane of projection is generally 45° (known as cavalier projection), although any angle less than 90° may be used. In an oblique drawing, one face or plane is shown without distortion. For that reason, any object to be drawn should be placed with its irregular outline in the front plane; if the object is of regular shape, the longest side should face the front plane.

b. An oblique (fig. 47) is drawn on three axes similar to an isometric drawing except that one axis is drawn horizontally, one vertically, and one at an angle. Measurements are laid out along these axes representing the length, breadth, and thickness of the object, and the object completed as shown. Oblique circles (fig. 48) are drawn as true circles in the front plane and as approximate ellipses in the other planes by erecting perpendiculars at midpoint of the sides of the squares inclosing them.

42. Cabinet drawing.—Cabinet drawing is oblique drawing with all measurements on the oblique axis reduced one-half so as to overcome the distorted appearance of oblique drawing. Any angle may be used for the oblique axis of a cabinet drawing, but angles of 45° or 30° are generally preferred.

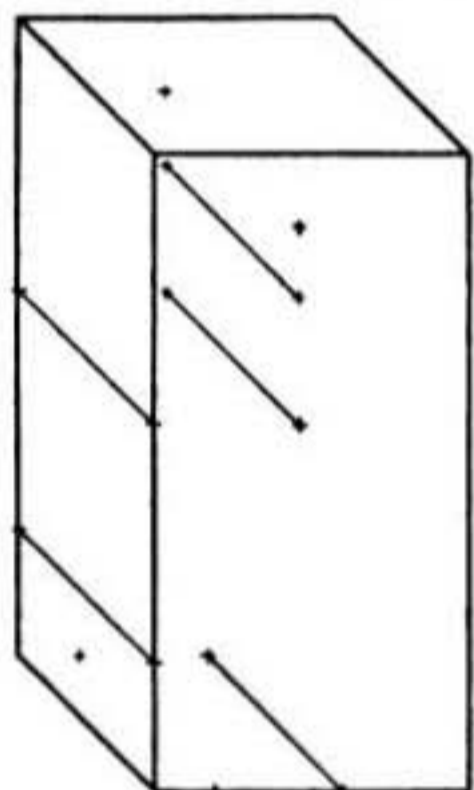
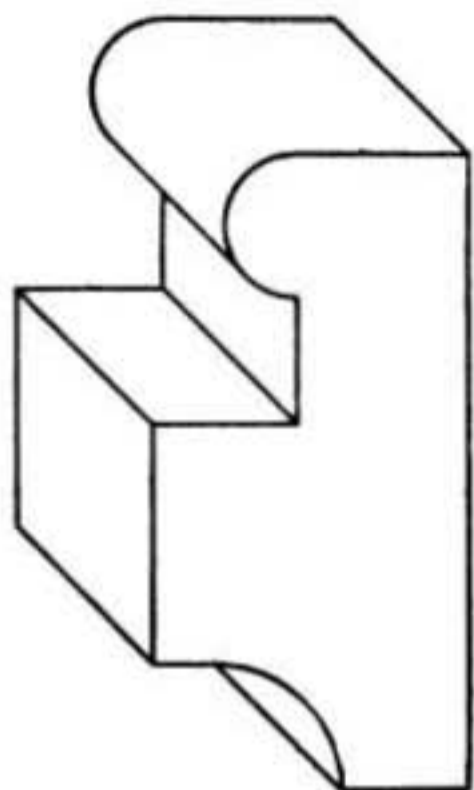

FIGURE 47.—Oblique drawing.

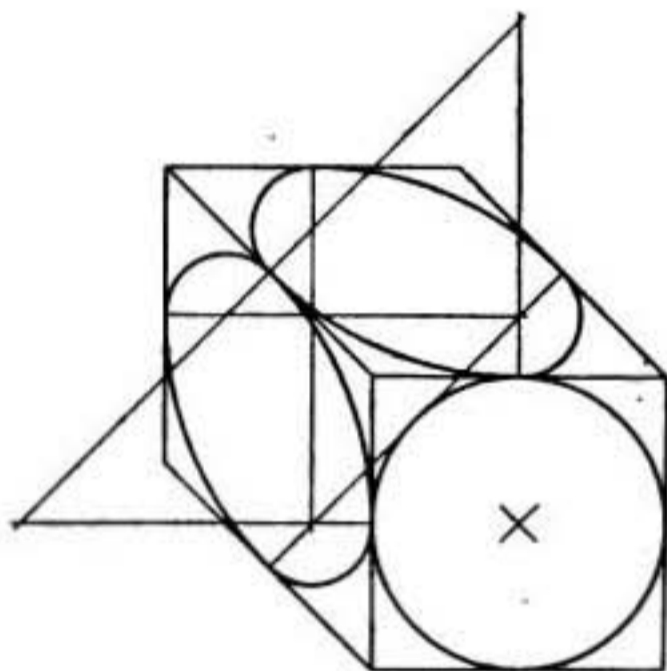
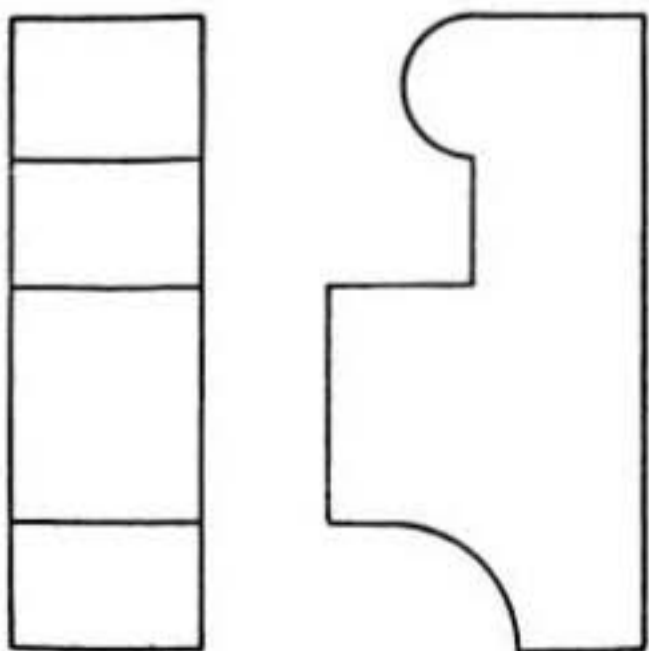

FIGURE 48.—Oblique circles.



SECTION VII

SECTIONAL VIEWS AND THREADED PARTS

	Paragraph
Sectional views.....	43
Threaded parts.....	44

43. Sectional views.—*a.* Frequently the usual views do not give a clear picture of the object. The difficulty generally lies with the invisible object lines, in which case a view into the interior of the object would help clarify the drawing. Such a view may be obtained by imagining enough of the exterior of the object removed to expose the internal construction. The type of section is determined by the amount of exterior removed.

b. A sectional view (fig. 49) is obtained by imagining the object cut away, as if by sawing. The path of the saw is considered the cutting plane, that is, the plane upon which the cut is made. If one portion of the object is then removed and a drawing made of the remaining portion, the lines formerly invisible are exposed to view. Since sectioning an object is an imaginary operation, the other necessary views are not changed. The only addition is a cutting plane line, which traces the path of the cutting plane. A pictorial view of the object with the path of the cut traced by diagonal lines is shown in figure 49①. An orthographic projection with the side view sectioned is shown in figure 49②. The position of the cutting plane is located on the projected view by a cutting plane line. The view to be exposed after passing the cutting plane through the object is indicated by the direction of the arrows on the cutting plane line. When the cutting plane line coincides with the center line representing the symmetrical axis of the object, the cutting plane line may be omitted.

c. Uniformly spaced, 45°, fine, parallel lines, termed cross hatching or section-lining, are used to distinguish surfaces of material theoretically cut and exposed by the cutting plane. The spacing of cross hatching varies from $\frac{1}{32}$ to $\frac{1}{8}$ inch, depending upon the size of the drawing and the part. The symbols used to designate various materials in sectional view (and in outside view) are shown in figure 50. The rules governing the use of symbols and related principles are as follows:

(1) Assembly drawings are cross hatched with the symbol representing the actual material of each part in the assembly. In figure 51 different materials are shown—cast iron, babbitt, bronze, and steel.

(2) Detail drawings are cross hatched with the symbol for cast iron regardless of the material used; this practice simplifies the cross

hatching. The material of which the object is made is specified as a note on the drawing.

(3) Invisible object lines and details beyond the cutting plane are not shown on sectional views unless required for the necessary description of the object.

(4) When a cutting plane passes through a rib, web, or similar parallel element, the cross hatching is omitted from those parts (A-A, fig. 52).

(5) (a) When adjacent parts are shown in section (fig. 53①) the cross hatching is shown in opposite directions. Where a third part

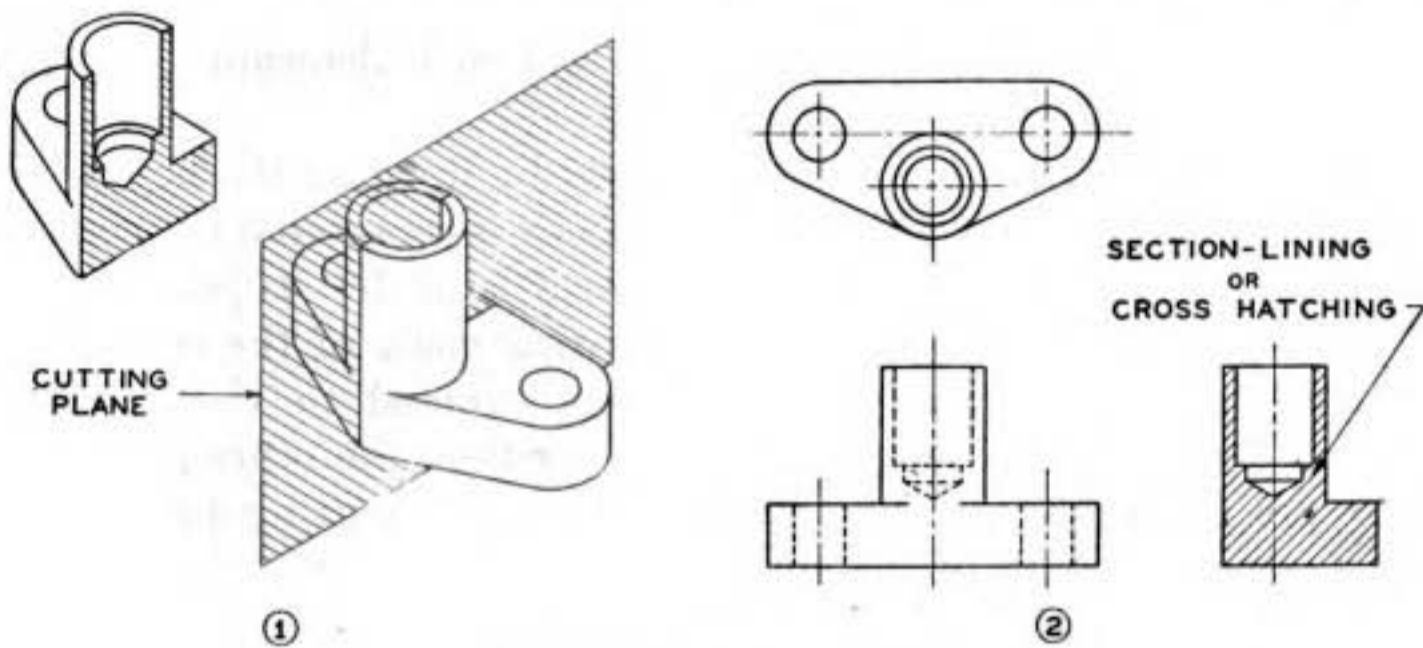

FIGURE 49.—Sectional view.

is adjacent to two other parts, the angle of its cross hatching is made 30° or 60° .

(b) Where a part is sectioned in more than one place, the spacing and direction of the cross hatching is the same.

(c) If 45° cross hatching would closely approach being parallel to one of the sides of the object, a different angle of cross hatching is used.

(6) Parts such as bolts, nuts, rods, rivets, pins, keys, and shafts, the axes of which lie in the cutting plane, are not considered as cut lengthwise by the cutting plane, and therefore are not sectioned (fig. 53②). When the cutting plane passes at right angles to such parts, they are cross hatched as are other parts of the object.

d. (1) A full sectional view (fig. 49) is obtained by passing a cutting plane across the entire object. In this operation, one-half of the object is considered removed; the other half, with the interior exposed to view, is drawn or projected in the manner of any other orthographic view.

(a) A sectional view need not be taken along a single, continuous cutting plane. The cutting plane may be turned or offset (A-A, B-B,

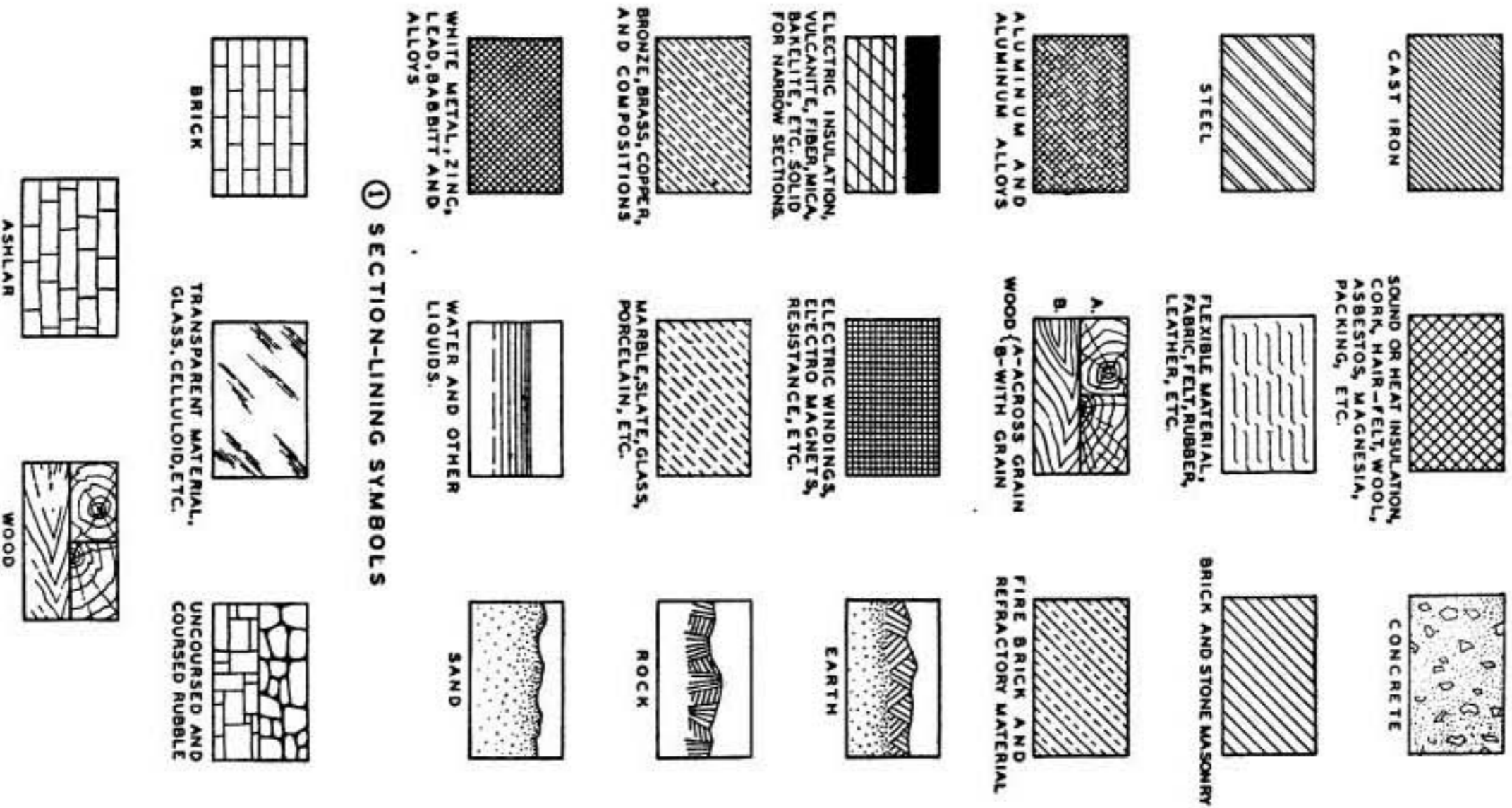

FIGURE 50.—Symbols for materials.

fig. 52) to pass through other features to show the construction to better advantage. The cutting plane line is lettered at the points of change of direction.

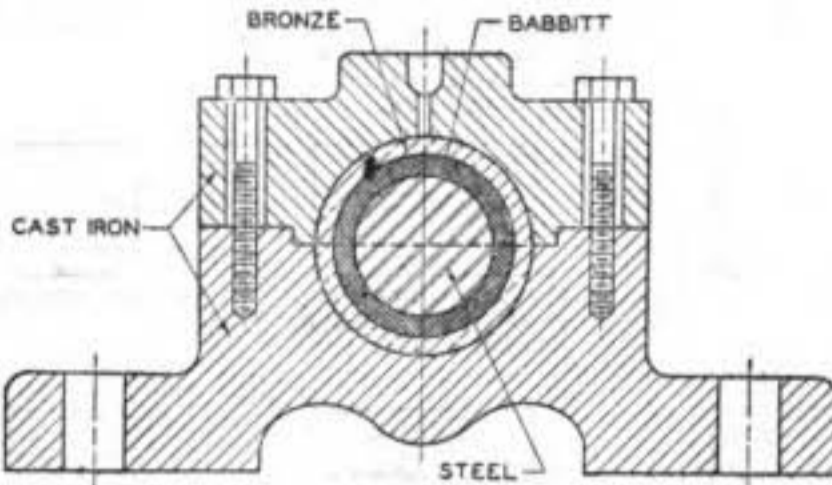

FIGURE 51.—Materials as shown on assembly drawing.

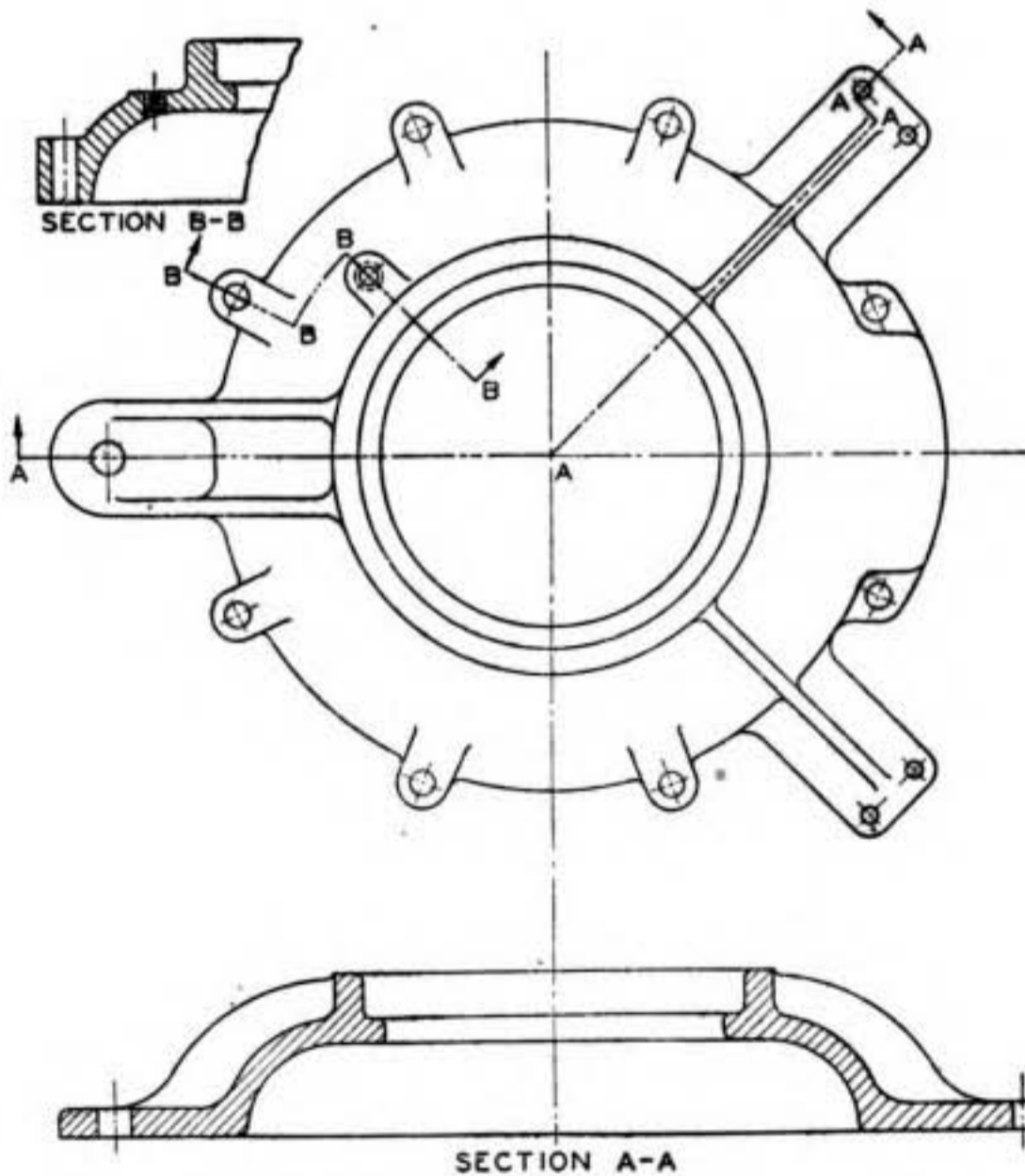

FIGURE 52.—Method of showing rib or web in sectional view.

(b) When the true projection of a piece would be misleading, parts such as ribs or arms should be rotated until parallel to the plane of the section or projection (figs. 52 and 54). Similarly, holes in a flange in section (or elevation) are shown at their true distance from the center rather than in true projection (fig. 55).

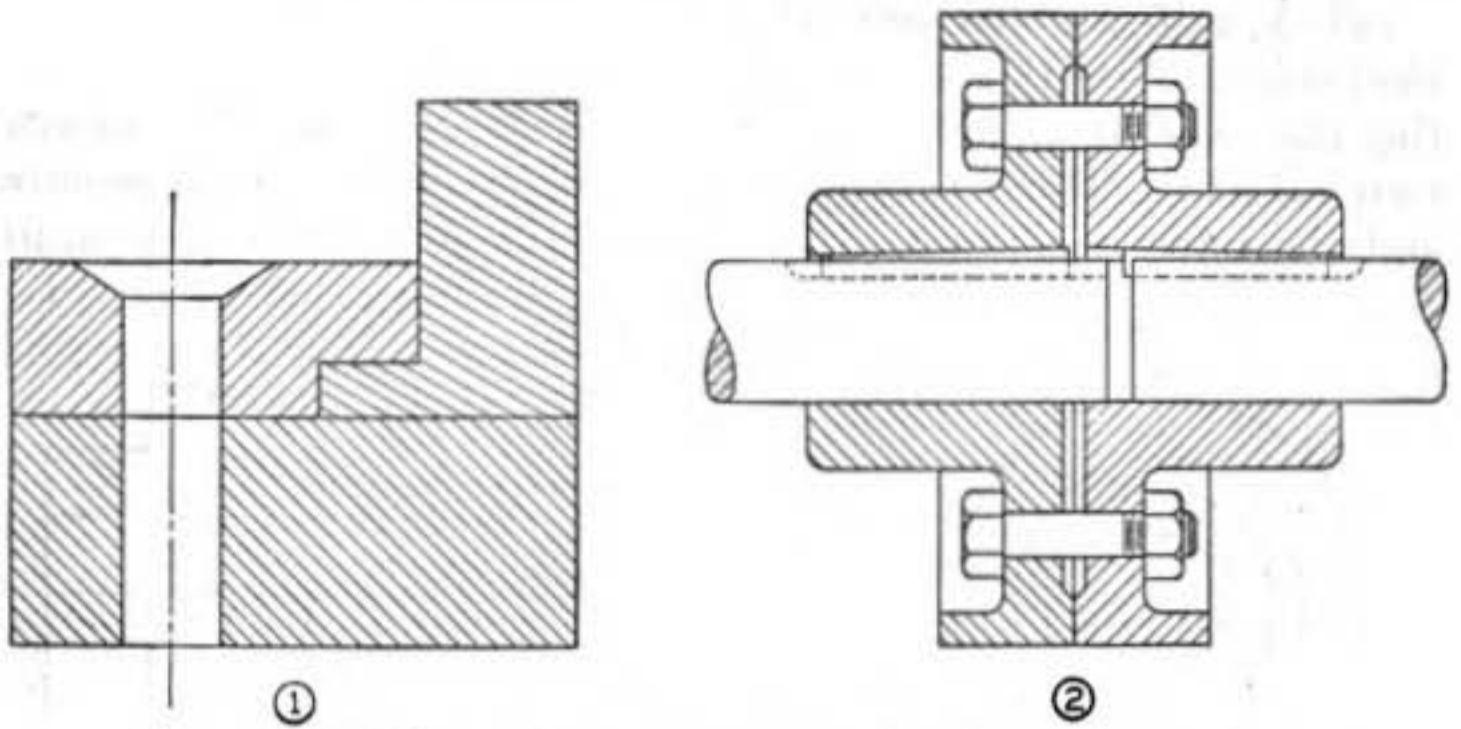

FIGURE 53.—Adjacent parts, bolts, nuts, shafts, etc., in sectional view.

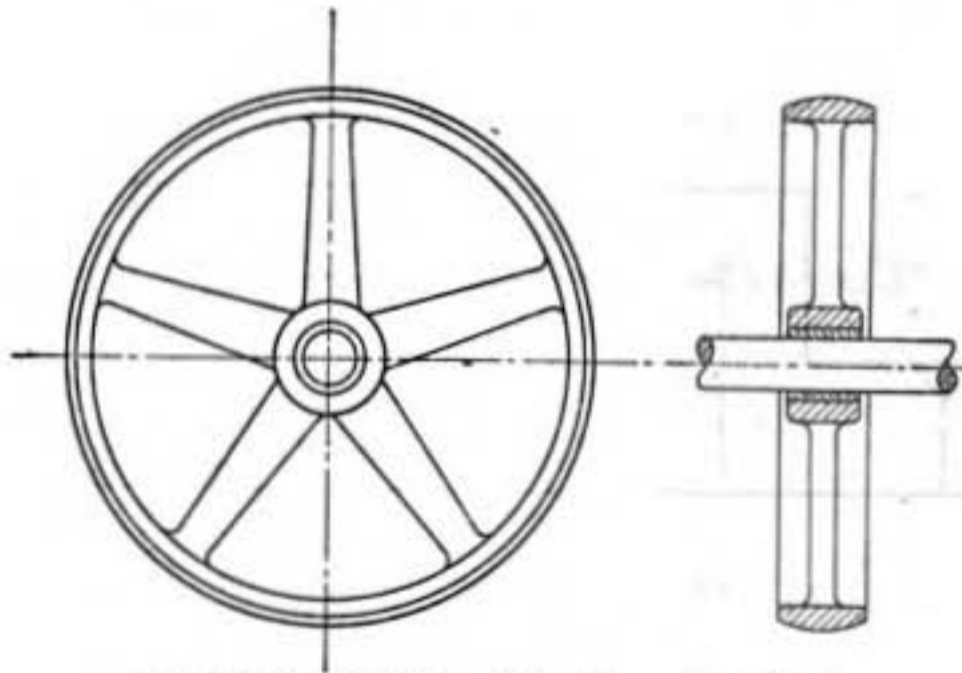

FIGURE 54.—Rotation into plane of section.

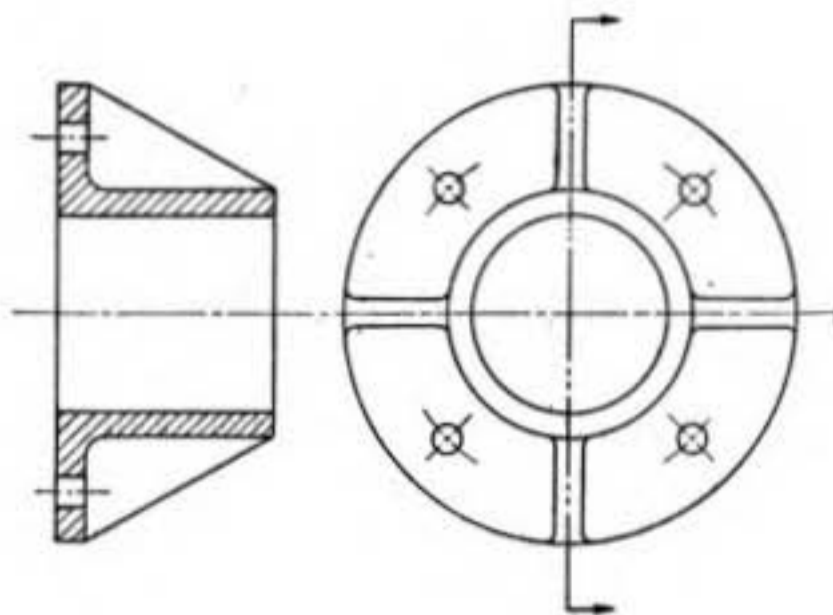

FIGURE 55.—Holes in flange shown at true distance from center.

(2) A half-sectional view (fig. 56) may be drawn for a symmetrical object. This type of section is accomplished by passing two cutting planes at right angles to each other along the center lines or symmetrical axes. Thus one-quarter of the object is considered removed and the interior exposed to view. Invisible outlines are generally

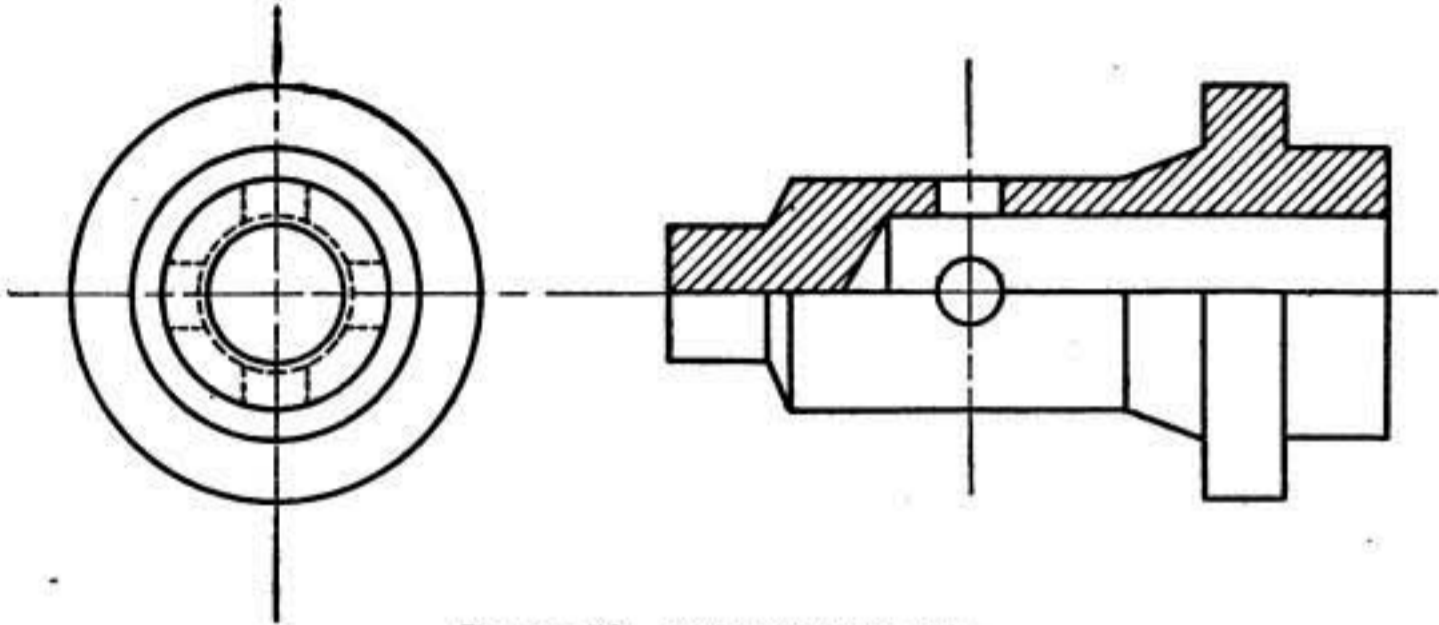

FIGURE 56.—Half-sectional view.

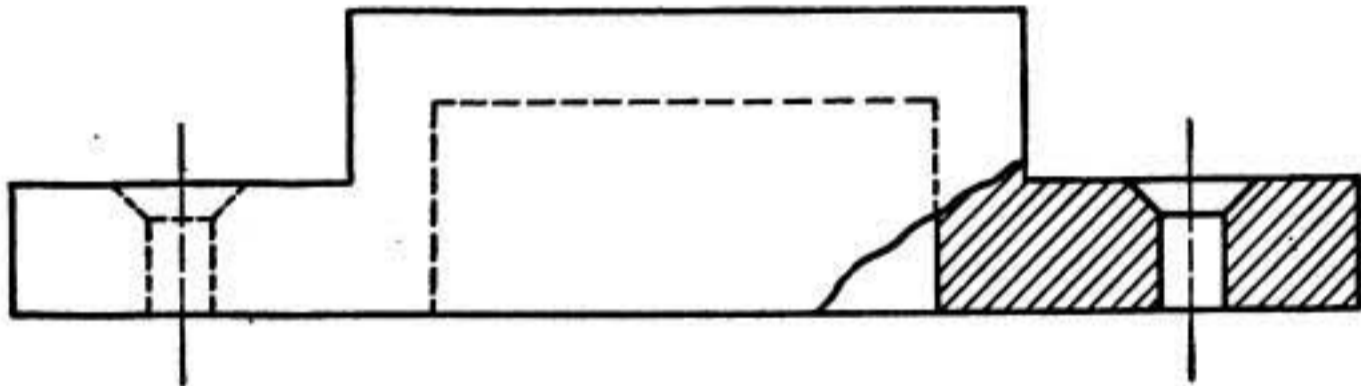

FIGURE 57.—Broken-out section.

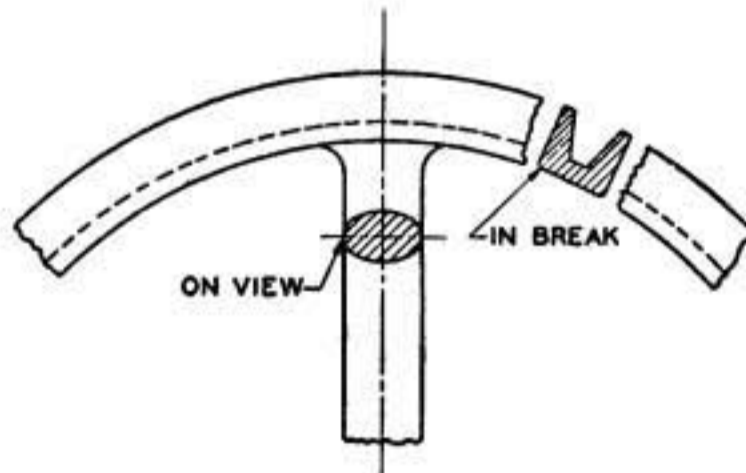

FIGURE 58.—Revolved section.

omitted from the sectioned and unsectioned portions of the object but are shown in the unsectioned portion if the object is thus more clearly described. The half section provides a view which shows the internal and external features of an object.

(3) A broken-out, or partial, section (fig. 57) is employed when it is desired to show only a portion of the object in sectional view. Frequently a broken-out section will eliminate the necessity of showing

a full or half-sectional view. The broken-out section is bounded at the break by a short break line.

(4) A revolved section (fig. 58) is used to show cross sections of arms, spokes of wheels, brackets, etc. The section is obtained by passing a cutting plane perpendicularly through the axis of the part and then revolving the sectioned portion one-quarter turn, showing the cross section on the longitudinal view. The revolved section may be shown directly on the view or in a break in the view.

(5) A detail section (B-B, fig. 52) is shown at some convenient location on the paper, entirely separate and removed from the regular projected view. The detail section is located on the view by a cutting plane line. In order to clarify the construction of small details,

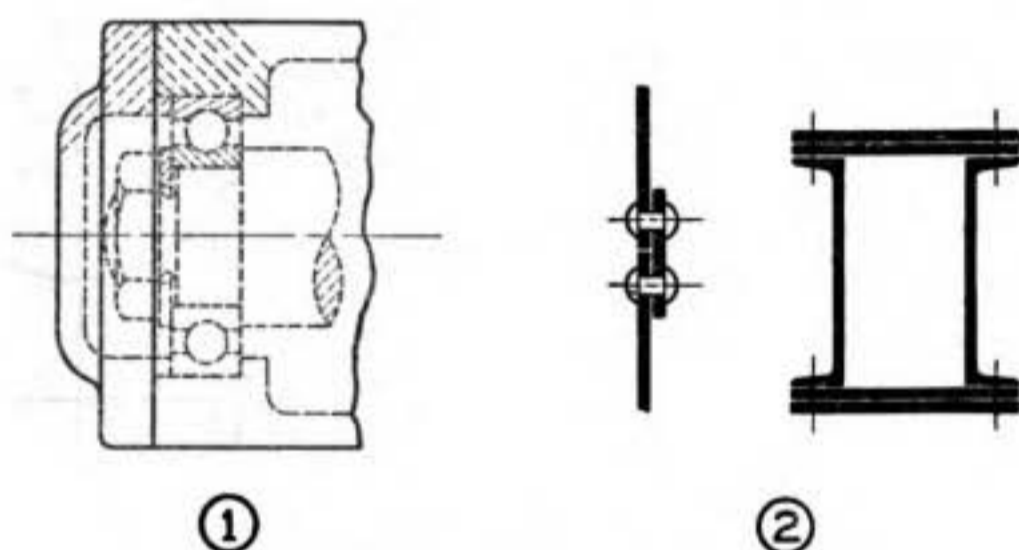

FIGURE 59.—Phantom and thin sections.

this type of section is frequently drawn to a larger scale than the view on which the section is indicated.

(6) A phantom section (fig. 59①) is indicated on an outside view by dashed cross hatching, and is used to show interior construction; the use of an additional view may occasionally thus be eliminated. Phantom sections are also used to indicate adjacent parts.

(7) Sections such as sheet metal, structural members, packing, gaskets, etc., which are too thin for cross hatching, may be shown solid on the sectional view (fig. 59②), with a space between thicknesses of such parts.

44. Threaded parts.—*a.* (1) The use of screw thread representation on working drawings is extensive. The features of a screw thread are shown in figure 60. The relative terms (fig. 60①) may be defined as follows:

(*a*) A screw thread is a ridge of uniform section in the form of a helix on the external or internal surface of a cylinder or cone.

(*b*) The pitch is the distance from a point on a screw thread to a corresponding point on the next thread measured parallel to the axis.

(c) The lead is the distance a screw advances axially in one turn. On a single-thread screw the lead and pitch are identical; on a double-thread screw the lead is twice the pitch, etc.

(d) The major diameter is the largest diameter of a screw thread.

(e) The minor diameter is the smallest diameter of a screw thread.

(f) The pitch diameter is referred to as the effective diameter, and is equal to the major diameter minus the thread depth.

(g) The angle of thread is the angle included between the sides of the thread measured in an axial plane.

(h) The crest is the top surface joining the two sides of a thread.

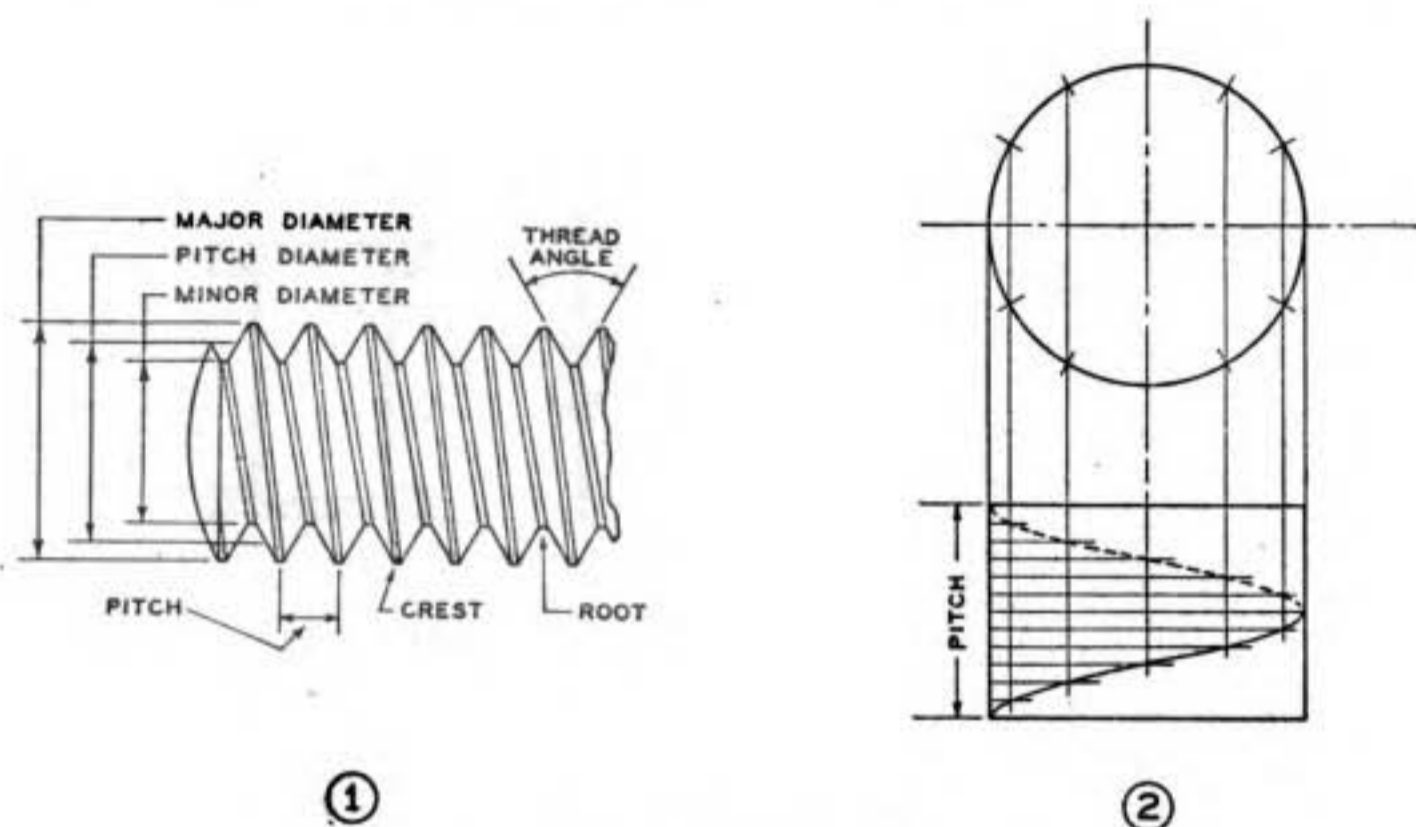

FIGURE 60.—Features of a screw thread.

(i) The root is the bottom surface joining the sides of two adjacent threads.

(j) Clearance is the space between the crest of a thread and the root of its mating thread.

(2) The helix, which is the basic curve of screw threads, is the path traced by a point on the surface of a cylinder as it moves uniformly around the cylinder and at the same time moves uniformly lengthwise on the cylinder. To accomplish the helix the circumference of the top projection of the cylinder is divided into a number of equal parts (fig. 60②), and the pitch on the front projection is divided into the same number of equal parts. The perpendiculars from the points on the circumference intersect the horizontal lines through the corresponding points on the front projection to locate the points through which the helix is drawn.

b. Various forms of screw threads are illustrated in figure 61.

The American Standards Association has adopted the American (National) screw thread. This thread has extensive use in fastenings.

(1) Common forms are known as National Coarse Series, National Fine Series, Extra Fine (SAE) Series, Special 8-pitch, 12-pitch, 16-pitch Series, and American Standard Pipe Thread. The pipe thread (fig. 62) has a taper of $\frac{3}{4}$ inch per foot.

(2) Four classes of thread fits are established for general use, except for pipe threads, and designate the degree of looseness or tightness of mating threads. The classes of fits are designated as class 1

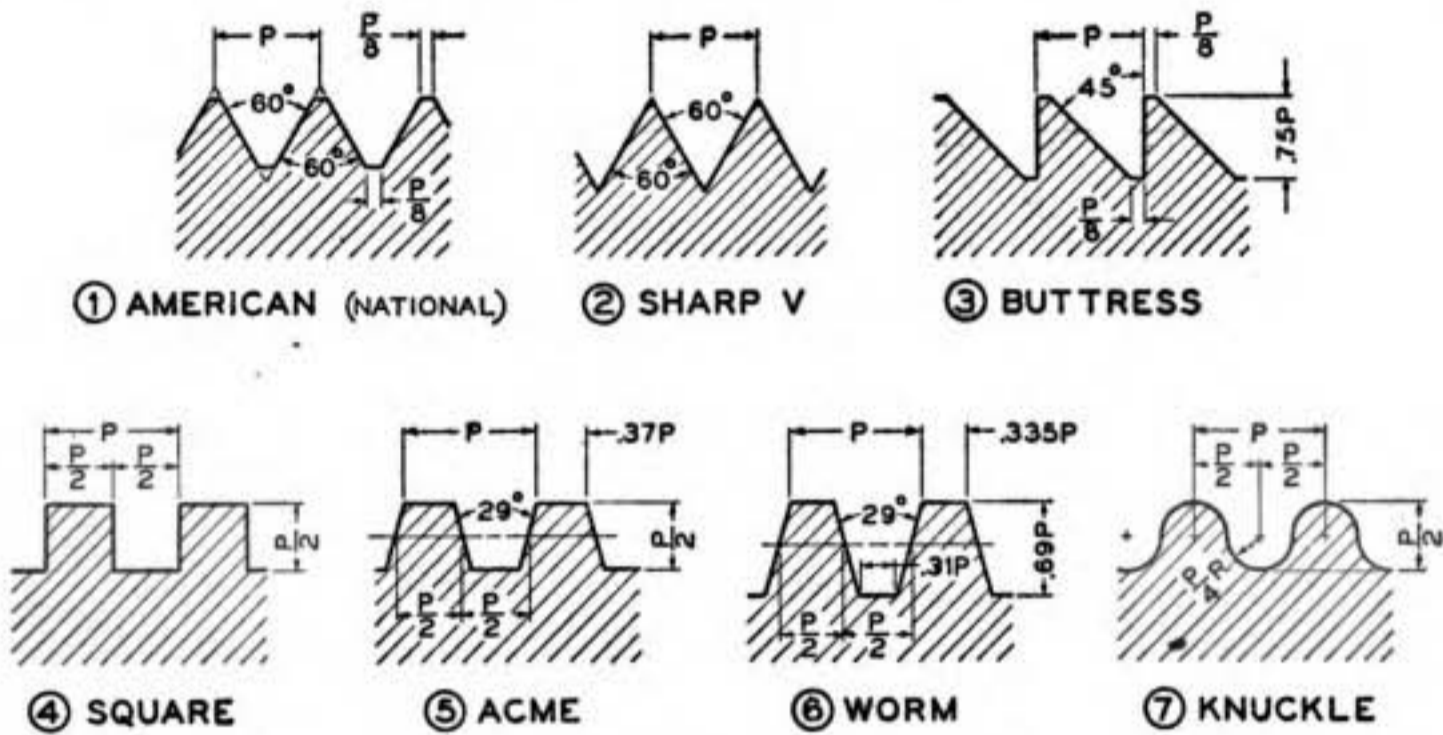

FIGURE 61.—Forms of screw threads.

(loose fit), class 2 (free fit), class 3 (medium fit), and class 4 (close fit).

(3) The thread series are generally expressed by symbols as follows: NC (National Coarse), NF (National Fine), EF (Extra Fine), and N (Special Series). The full designation of a threaded part having a diameter of $\frac{7}{16}$ inch, with 20 threads per inch, National Fine threads, class 3 fit, is $\frac{7}{16}$ -20-NF-3; a No. 10 bolt with the same type of threads and fit is expressed as 10-32-NF-3. If a left-hand thread is designated, the letters LH are added after the number of threads.

c. (1) The helix is not generally required for screw thread representation. A V-thread may be represented as shown in figure 63, in which the straight line is used instead of the helix. The flats at the root and crest are not shown. This type of representation is used for a thread having a diameter of more than 1 inch on the drawing.

(2) Thread symbols are conventionalized as shown in figures 64 to 69, inclusive. The size and length of thread and depth of tap should be indicated on the drawing.

(a) Regular external thread symbols recommended for general use on assembly and detail drawings are shown in figure 64. Other than external threads in sectional view, the crests and roots of threads are shown as alternate long and short lines perpendicular to the axis. These lines may be of equal weight or the root line may be heavier.

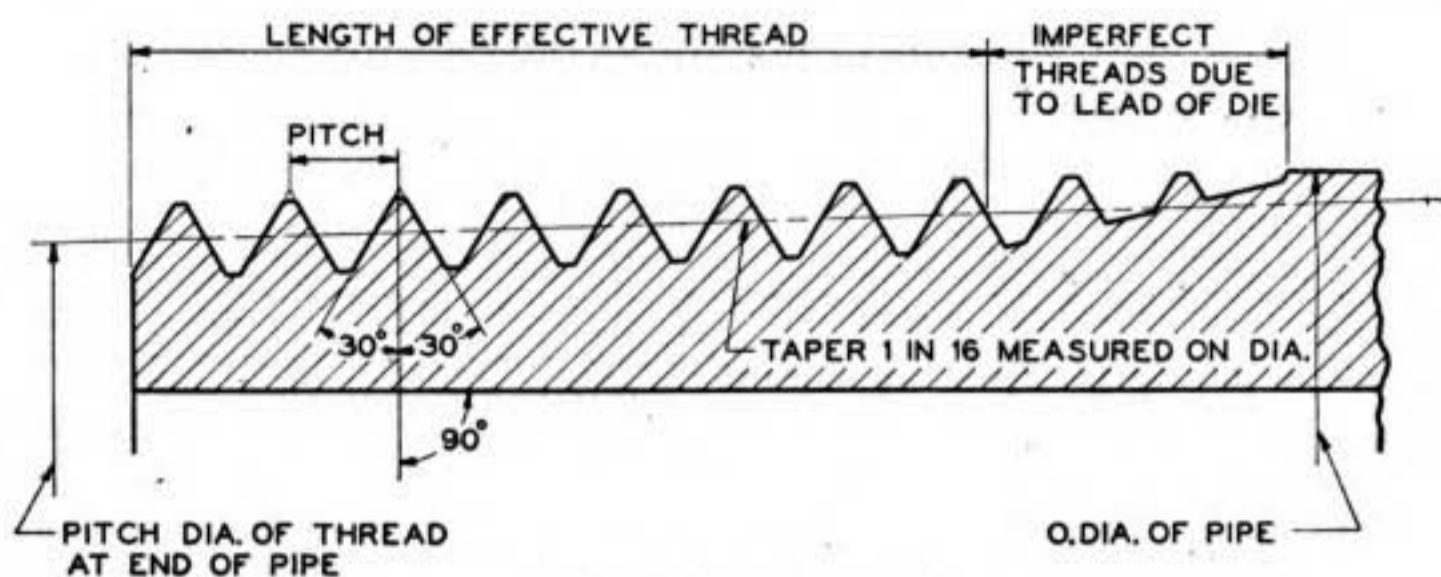

FIGURE 62.—Pipe thread.

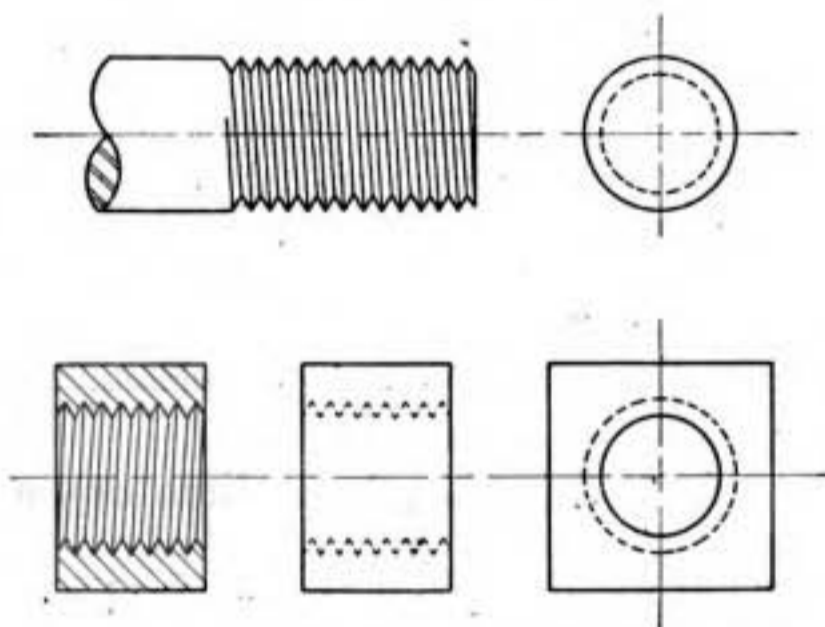

FIGURE 63.—Thread pictures.

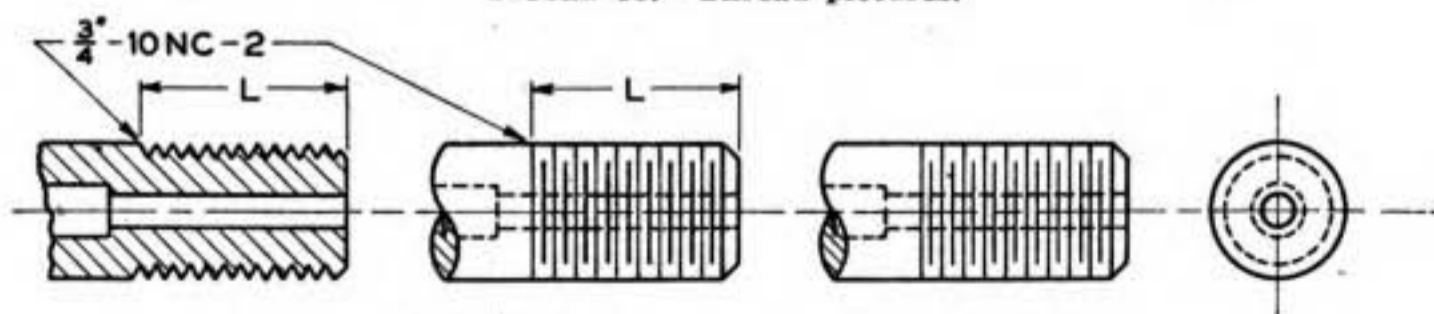

FIGURE 64.—Regular symbols for external threads.

Spacing of root and crest lines need not be scaled but may be judged by eye to look well.

(b) Regular internal thread symbols are shown in figure 65.

1. When the threads are tapped through, the representation is as shown in figure 65①.
2. When the point of the tap drill does not extend through the part, the representation is as in figure 65②.

3. The representation in figure-65③ is employed to indicate a bottoming tap, when depth of thread is the same as depth of drill, or when it is not necessary to specify both depth of thread and depth of drill.

(c) Simplified symbols for external and internal threads are shown, respectively, in figures 66 and 67. At a depth approximately equal to

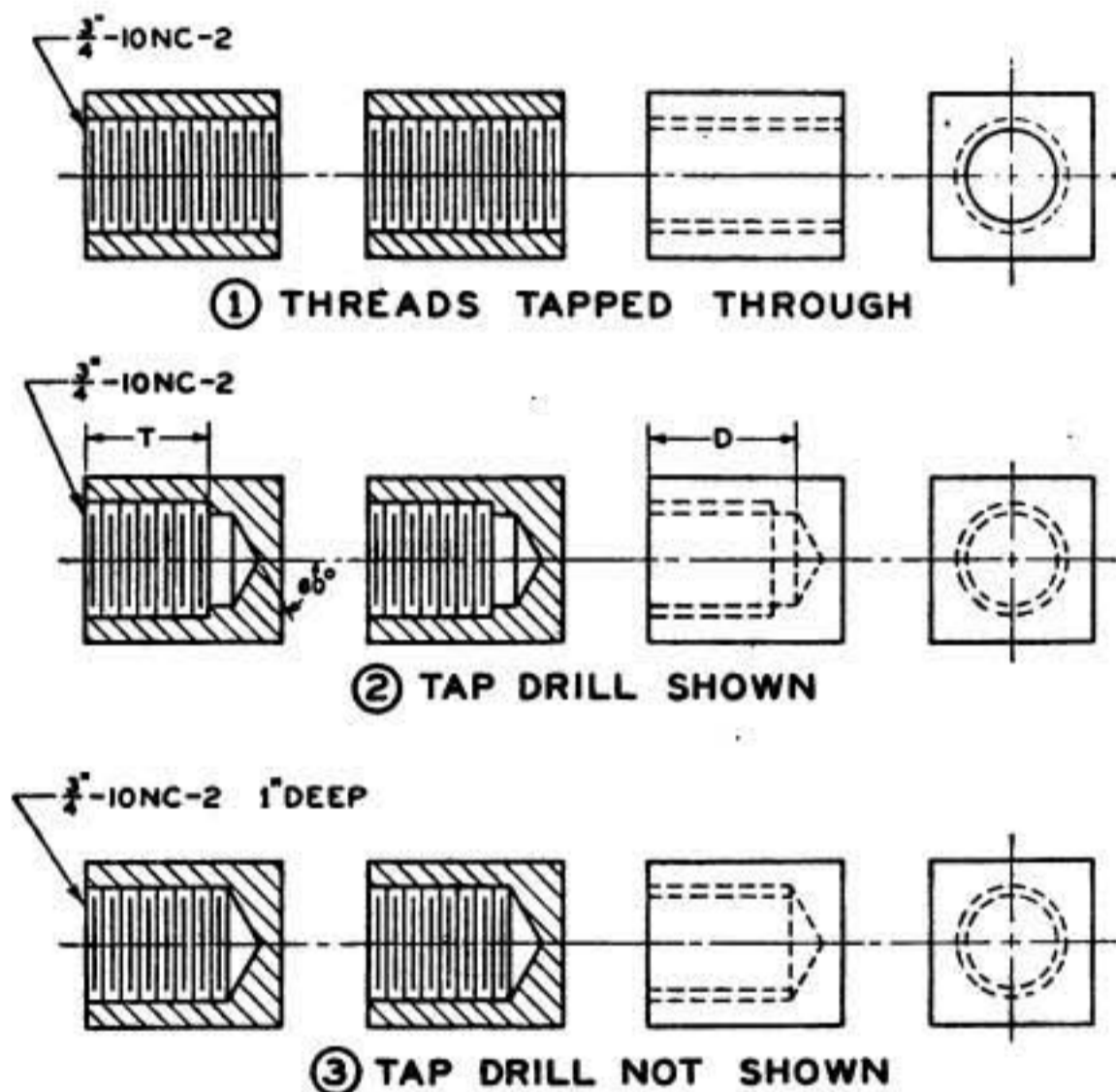

FIGURE 65.—Regular symbols for internal threads.

that of the thread, hidden lines are drawn parallel to the axis to represent the threads. The simplified method of representation is not recommended for either exteriors or sectional views of assembled parts.

(d) Pipe threads are represented as shown in figure 68. The taper need not be indicated but may be shown if desired.

(e) An assembly of threaded parts is shown in figure 69.

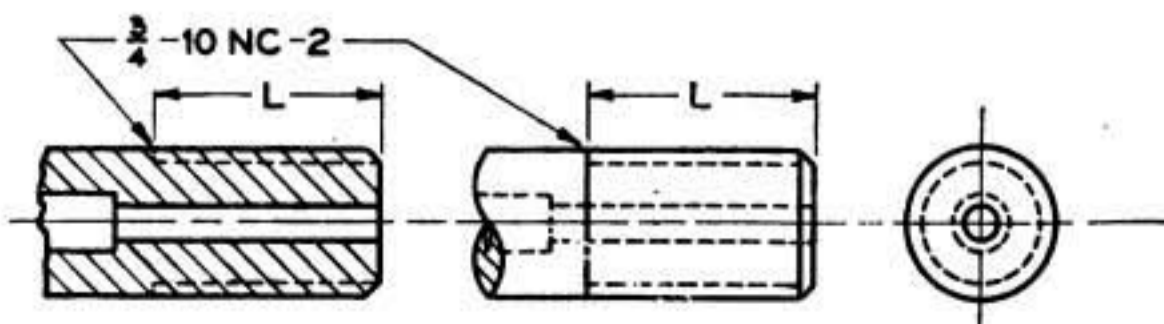

FIGURE 66.—Simplified symbols for external threads.

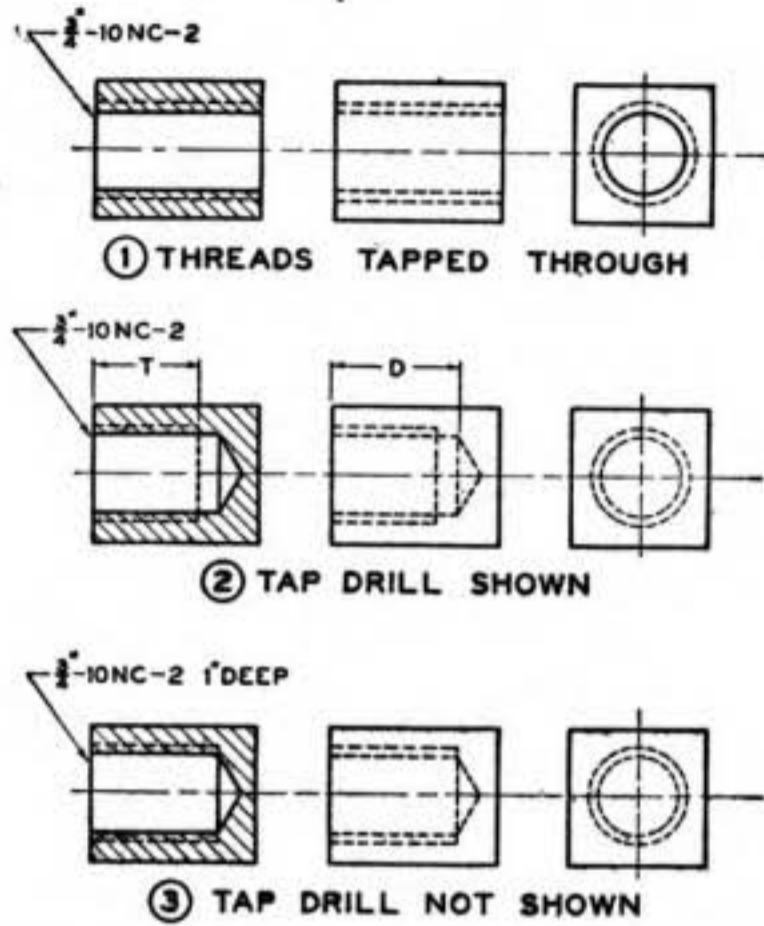

FIGURE 67.—Simplified symbols for internal threads.

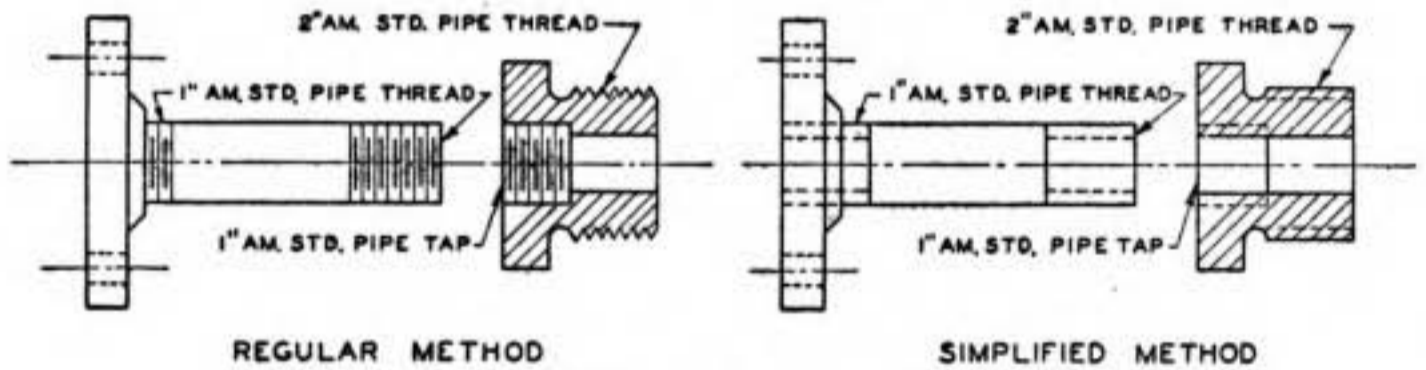

FIGURE 68.—Representation of American standard pipe thread.

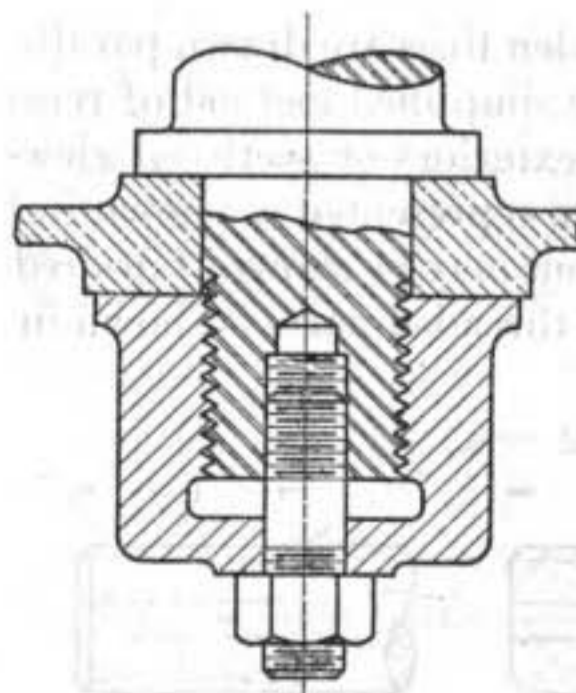

FIGURE 69.—Assembly of threaded parts.

SECTION VIII

SCALES, DIMENSIONS, AND NOTES

	Paragraph
Scale of drawings.....	45
Dimensions.....	46
Notes.....	47

45. Scale of drawings.—*a.* (1) Objects are drawn full size when the details thereof are clearly shown and the size of the paper will conveniently permit.

(2) Enlarged drawings of views or sections are made when the actual size of the object is so small that full-size representation would not clearly present the features of the object.

(3) Reduced-scale drawings are made of large objects that can be shown clearly in the smaller scale. The prime object in reducing the scale of drawings is to reduce the size of the drawing; therefore, as small a sheet is used as is practicable without crowding the views. The scale of drawings should not be reduced to such an extent that sectional views, notes, or tabulations cannot be added. Considerable clear space should always be left below the change block for the enlargement of this block.

b. (1) The scale of a drawing is generally noted in the title block. When all views on a drawing are actual size the scale may be stated as "Full size"; in some practice, when the object is drawn full size the scale is not shown.

(2) When one or more views or sections are enlarged the notation "Enlarged view" or "Enlarged section," as the case may be, is placed under the enlarged representation.

(3) (*a*) When all views are in the same reduced scale, the scale is noted in accordance with such reduction, as "One-half size," or $6''=1'$.

(*b*) When the main views are in one reduced scale and other views or sections are in another scale, each view or group of views has its own scale shown.

46. Dimensions.—*a.* (1) Information as to the shape of the object is provided by the various views on the drawing. These shape representations must have dimensions applied to the various features to indicate the size of the object. Dimensions, as given, refer to the actual size of the object to be constructed, regardless of the scale to which the drawing is made.

(2) A drawing must be so dimensioned that the parts shown thereon can be made without necessity of scaling the drawing. Dimensions should not be duplicated on various views or on a single view except

where they will add to the clarity of the drawing, and no more should be given than those required to produce the part. Dimensions of parts that can be measured or that can be produced with sufficient accuracy by using an ordinary scale should be written in units or common fractions. Parts requiring greater accuracy should be dimensioned in decimal fractions. Wire, tubing walls, sheet metal,

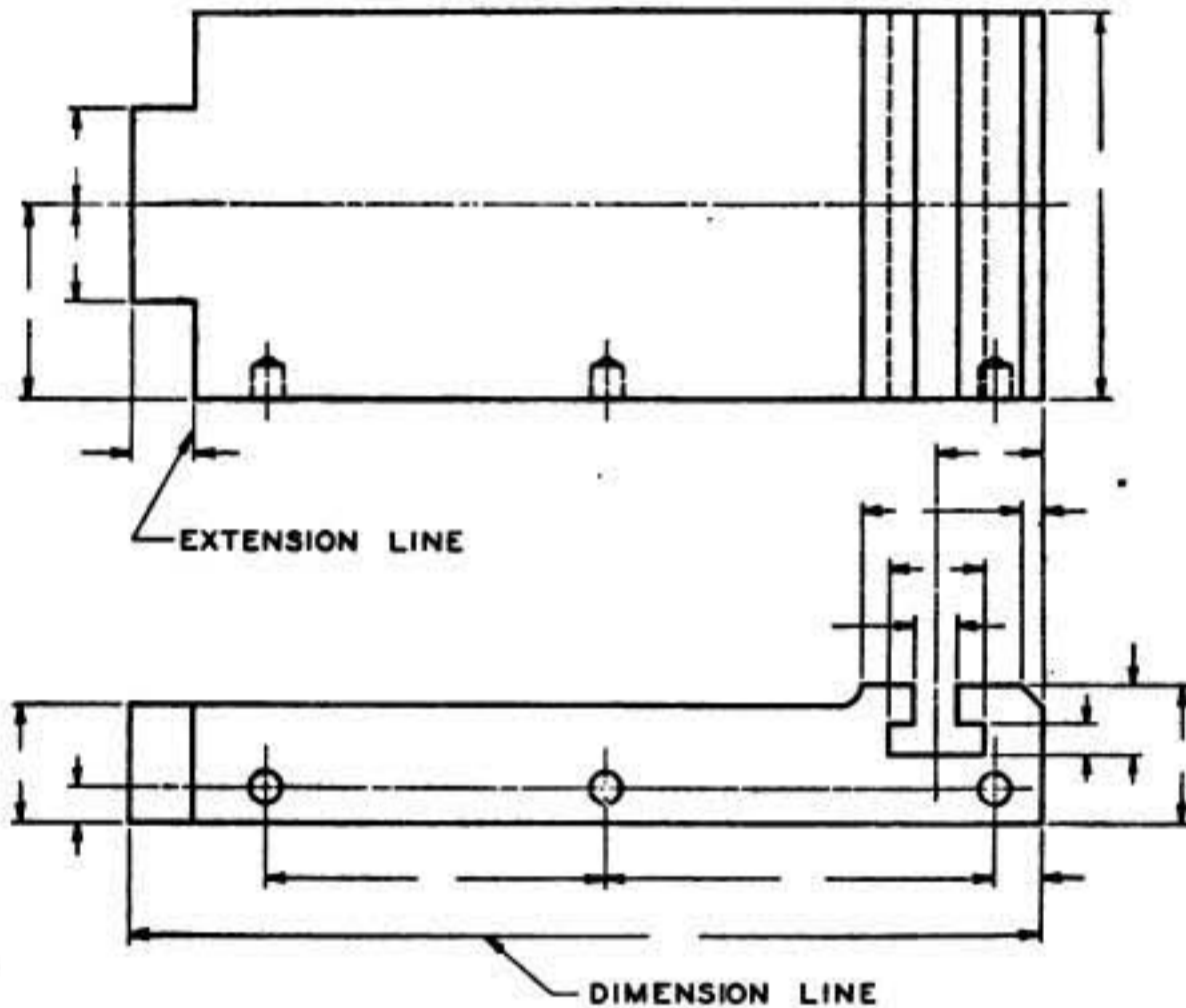

FIGURE 70.—Dimension and extension lines.

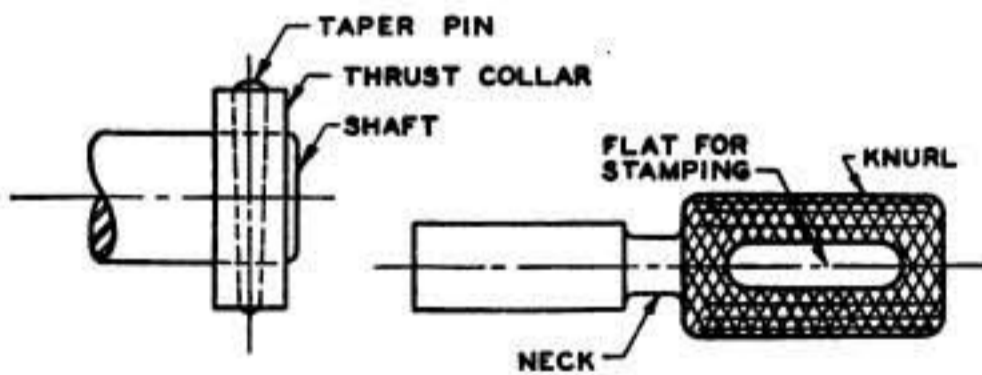

FIGURE 71.—Method of placing leaders.

standard metal bars and shapes, etc., should be described by the commercial designation followed by the dimension in decimals of an inch.

(3) (a) Dimensions up to and including 72 inches are preferably expressed in inches, and those greater than this length in feet and inches.

(b) In structural drawings, dimensions of 12 inches or over should be expressed in feet and inches,

(c) In automotive, sheet metal, and some other practices, all dimensions are specified in inches.

(d) When all dimensions are given in inches, the inch symbol (") is preferably omitted. A note may be placed on the drawing stating that all dimensions are given in inches.

b. (1) A dimension line is broken near the center for a sufficient space to permit insertion of the dimension.

(2) Arrowheads on dimension lines are drawn approximately $\frac{1}{8}$ inch long and about $\frac{1}{3}$ as wide.

(3) Wherever convenient, dimension lines are located outside the view of the object represented, approximately $\frac{1}{4}$ inch from the outline of the drawing and other dimension lines. Where a dimension is placed within a sectional view, the cross hatching is kept clear of the dimension numeral.

(4) A center line should never be used as a dimension line. A

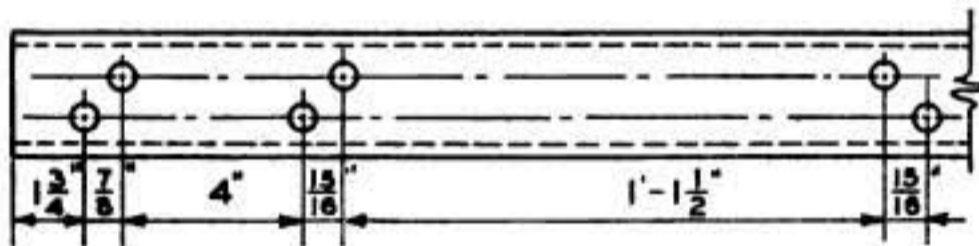

FIGURE 72.—Dimensions in structural drawing.

line of the part illustrated or an extension of such line should not be used as a dimension line.

(5) Extension lines are employed when the dimension is located outside the view. Extension lines are drawn approximately $\frac{1}{32}$ to $\frac{1}{16}$ inch away from the outline, and extend approximately $\frac{1}{8}$ inch beyond the arrowhead of the dimension line (fig. 70).

(6) Leaders, which are lines drawn from dimensions or notes to indicate their application (fig. 71), are of the same weight as dimension lines and are terminated by arrowheads at the drawing; leaders should not be curved nor made freehand.

c. (1) A dimension line should not pass through a dimension numeral. If unbroken lines are used, as is common practice in structural drawing, the dimensions are placed above the line (fig. 72).

(2) Dimension lines and their corresponding numerals should be placed so that they may be read from the bottom or right-hand edges of the drawing (fig. 73①). When fractional dimensions of less than 1 inch are given, the numerator should be placed above the dimension line and the denominator below. Where the fraction is part of a numeral, the division bar of the fraction is placed in line with the dimension line. All dimensions should be placed so as to read in the direction of dimension lines (fig. 73②). The practice with respect

to Army Air Forces drawings is to place the dimension numeral horizontal so that it may always be read from the bottom regardless of the direction of the dimension line.

(3) When there are several parallel dimension lines, the numerals should be staggered for ease of reading (fig. 74).

(4) Dimensions should be given from a base line, a center line, or a

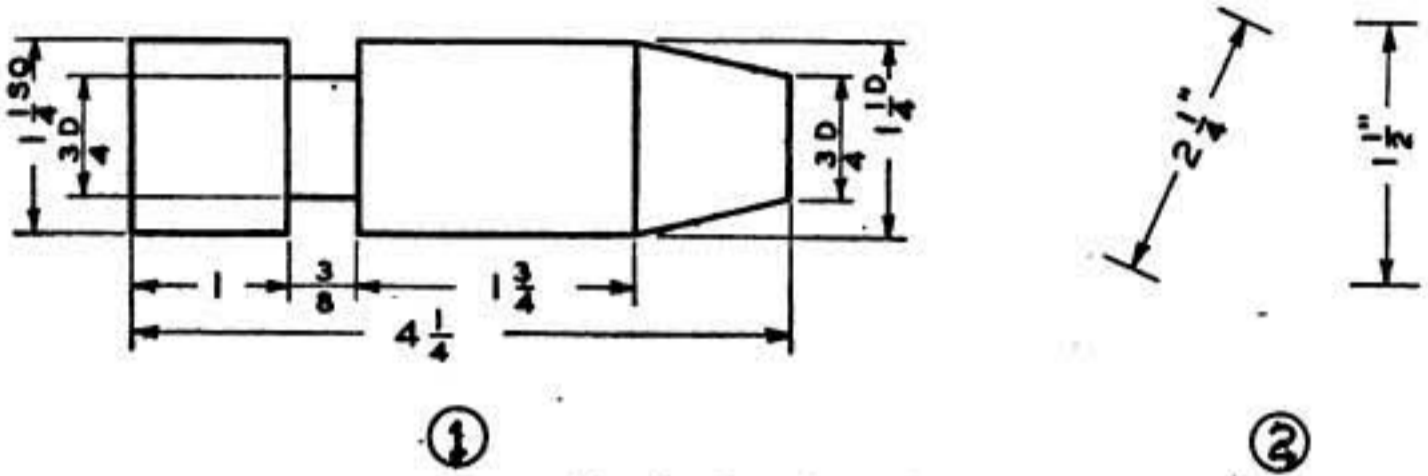

FIGURE 78.—Reading dimensions.

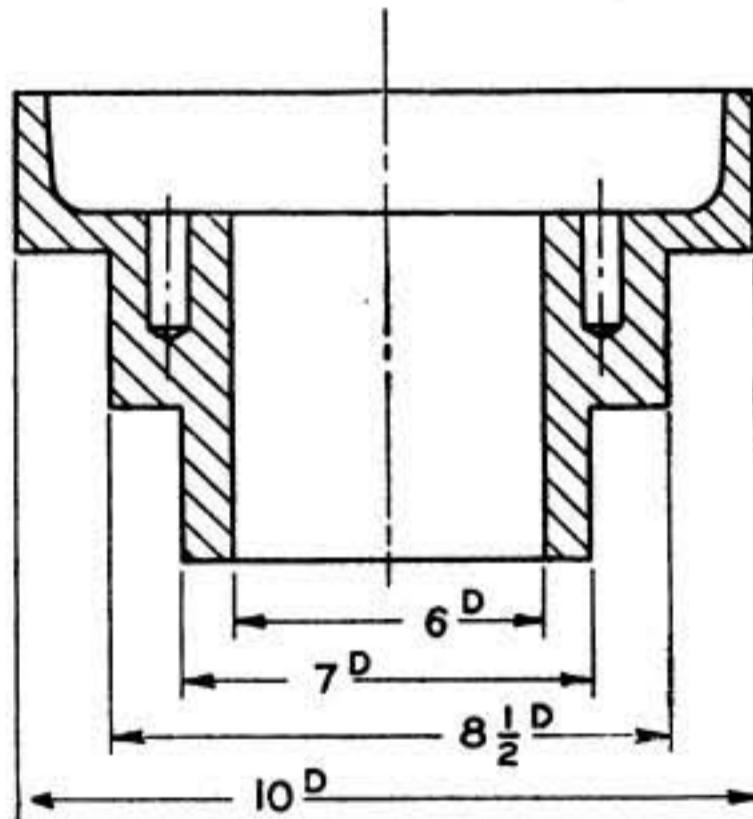

FIGURE 74.—Staggering of dimensions.

finished surface that can be readily established (fig. 75). The “V” with the letter inserted indicates the finished surface. Dimensions are given from invisible outlines only when necessary; sectional views may be employed to avoid such practice.

(5) Over-all dimensions should be placed outside the intermediate dimensions (figs. 70, 73, and 75). In dimensioning with tolerances, if an over-all dimension is used, one intermediate distance should not be dimensioned.

(6) When dimensioning in limited space the arrowheads should be reversed and the methods shown in figure 76① may be used.

(7) For dimensioning angles, an arc should be drawn as the dimension line and the dimension placed so as to read from the horizontal position (fig. 76②). An exception is sometimes made when dimensioning large angles, in which case the dimension may be placed along the arc. When angular dimensions are necessary, a horizontal or vertical center line (but not both) should be used as a base line and points located from it (fig. 76③). If holes are to be equally spaced, only one should be located and a note added "six holes equally spaced."

(8) A dimension indicating the diameter of a circle should be followed by the abbreviation "D" (fig. 74), except when it is obvious from

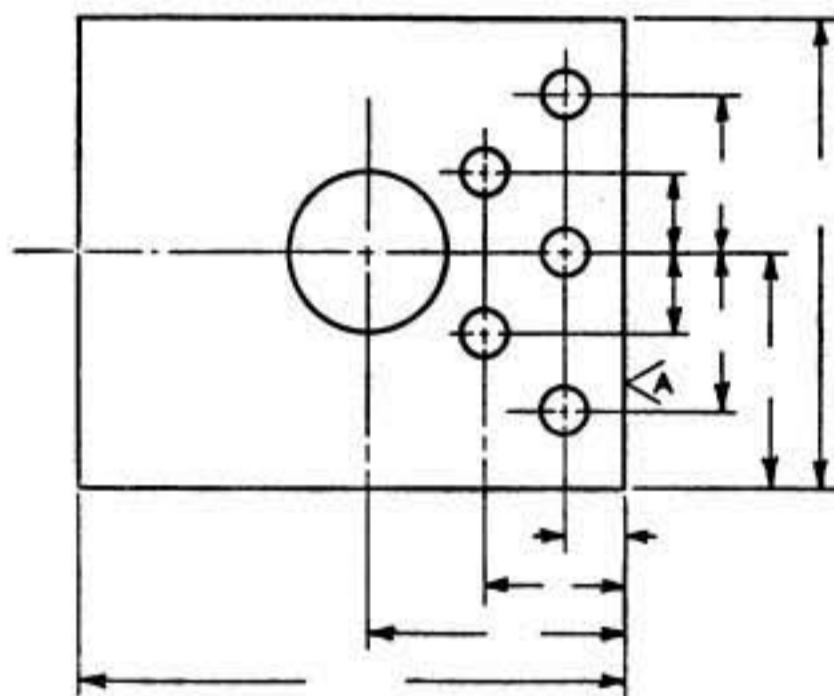

FIGURE 75.—Dimensioning from center line and finished surface.

the drawing that the dimension is a diameter (fig. 77①). In the latter figure, the dimension is shown well placed between the views.

(9) (a) The dimension of a radius should always be followed by the abbreviation "R" (fig. 77②). The center is indicated by a cross (or circle) and the dimension line has one arrowhead which is located at the outer extremity.

(b) A curved line may be dimensioned either by radii or offsets as shown in figure 77③ and ④, respectively.

(10) (a) Holes which are to be drilled, reamed, punched, swaged, cored, etc., should have the diameter given, preferably with a leader, followed by the word indicating the operation and the number of holes to be so made (fig. 78①).

(b) Holes which are to be machined after coring or casting should have finish marks and finished dimensions specified. For counter-bored holes the diameters and depths should be given, and for countersunk holes the angles and diameters should be given (fig. 78②).

(11) Accurate dimensions which are to be established with limit gage or micrometer should be expressed in decimals to at least three places, and the drawing should give the limits between which the actual measurements must come (fig. 79). For external dimensions, the

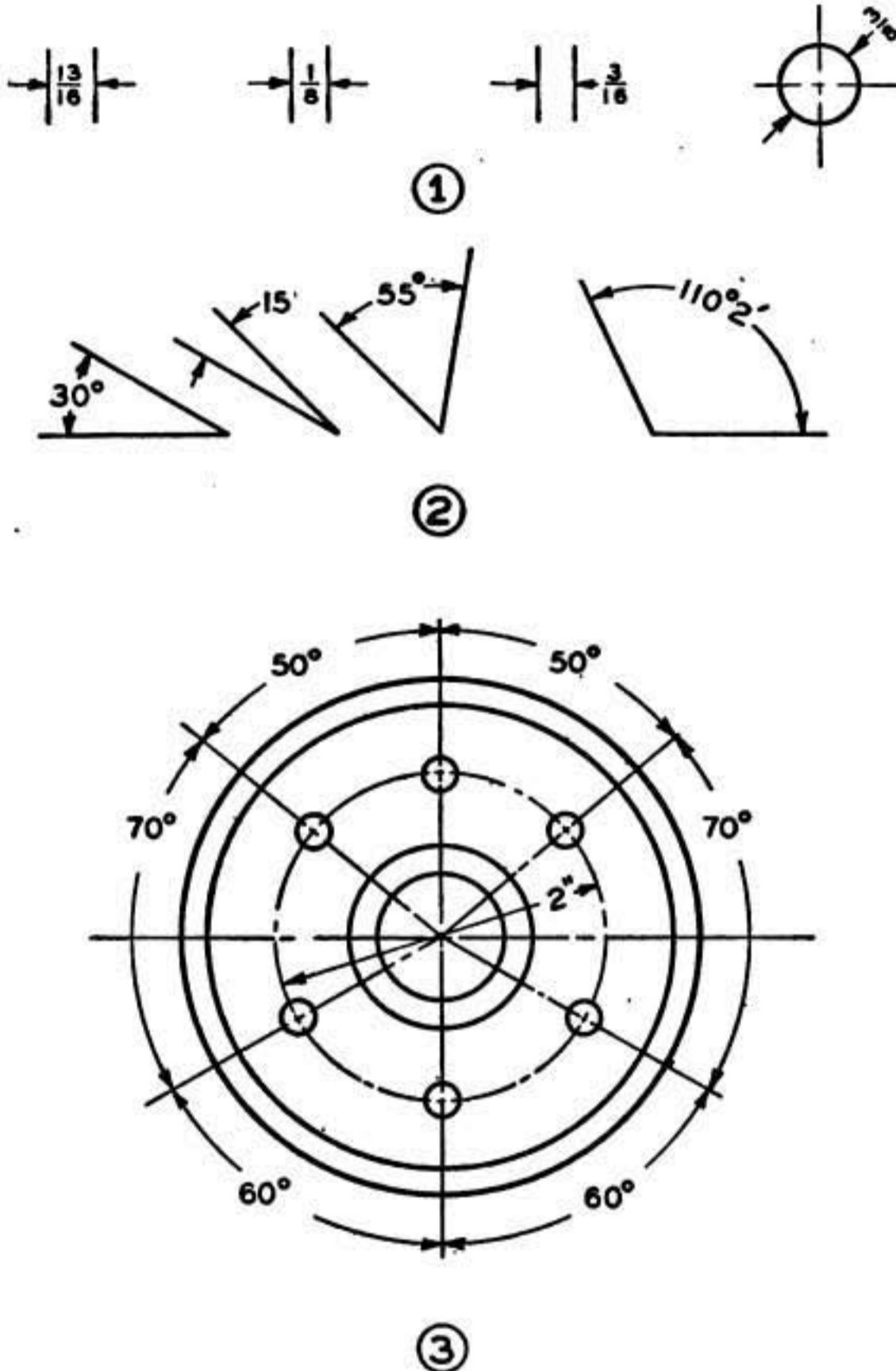

FIGURE 76.—Dimensioning unlimited space and angles.

maximum limit is placed above the line and for internal dimensions the minimum limit is placed above the line. This method should be used for smaller parts and where gages are extensively employed. A second method, used for larger parts and where few gages are employed, is to give the calculated size to the required number of decimal places,

followed by the tolerances plus and minus, with the plus above the minus, as $8.625D \begin{matrix} +.000 \\ -.002 \end{matrix}$.

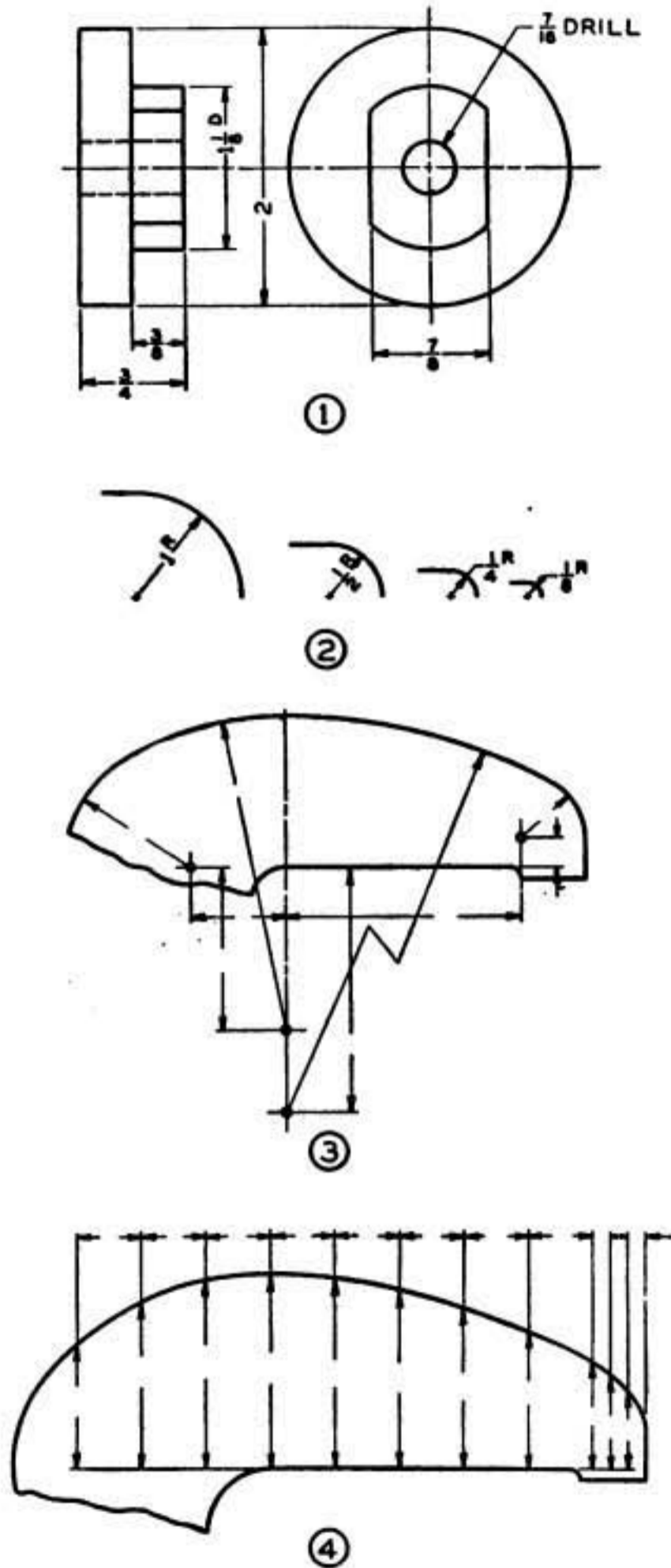

FIGURE 77.—Dimensioning circles, arcs, and curves.

(12) The difference in diameter or width in 1 foot of length is known as the "taper per foot."

(a) With standard tapers, give one diameter or width, the length.

and insert a note on the drawing designating the taper by number taken from American Standards.

(b) With special tapers, when the slope is specified, the length and

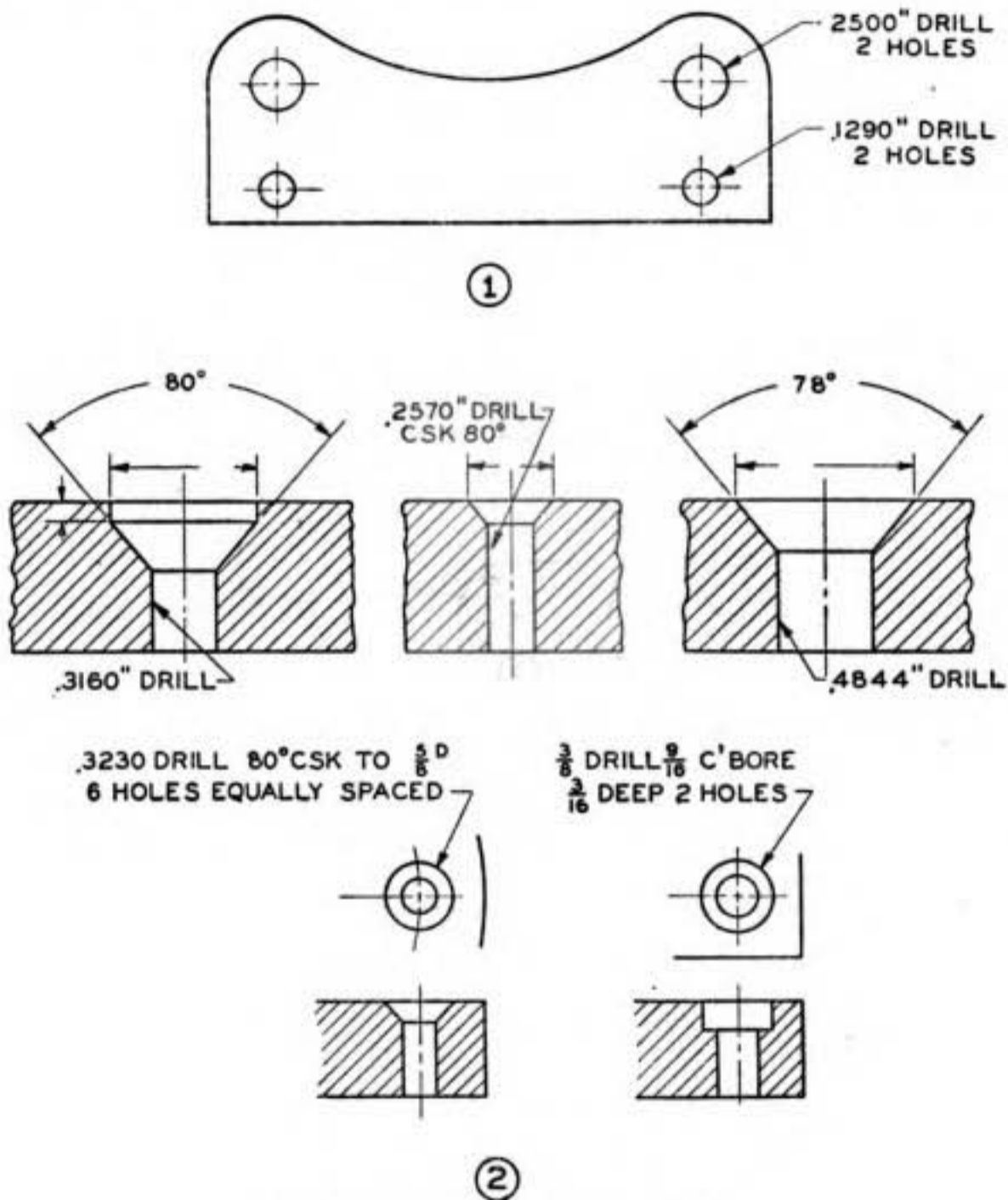

FIGURE 78.—Dimensioning holes.

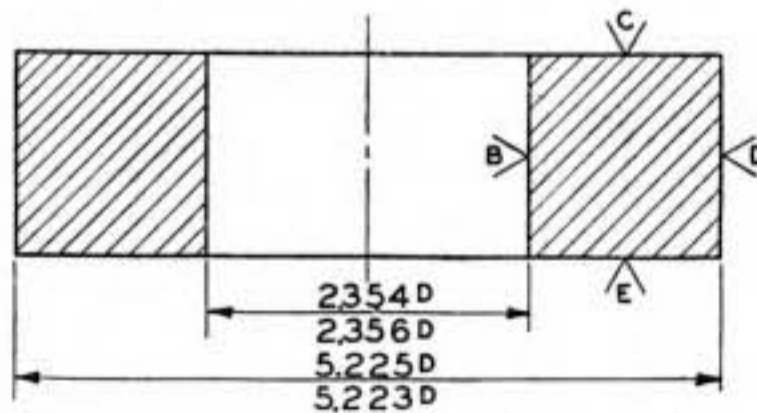

FIGURE 79.—Dimensioning with tolerances.

only one diameter should be given, or the diameters at both ends of the taper should be given and the length omitted (fig. 80).

(c) In certain instances where very precise measurements are necessary, the taper surface, either external or internal, is specified by

giving a diameter at a certain distance from a surface and the slope of the taper.

(13) (a) If a dimension must be changed, the changed numeral should be underlined or otherwise marked. It is customary to note changes in dimensions in a tabulation (change block) on the drawing and refer to them by letters or symbols placed after the altered dimensions.

(b) If a dimension is "not to scale," it is so noted at the dimension. If numerous dimensions on the drawing are "not to scale," such fact should be stated at the place where the scale of the drawing is ordinarily noted.

47. Notes.—*a.* (1) Notes are not intended to supersede dimensions on drawings, but to give information and instructions which cannot be shown otherwise, or to avoid crowding on complicated

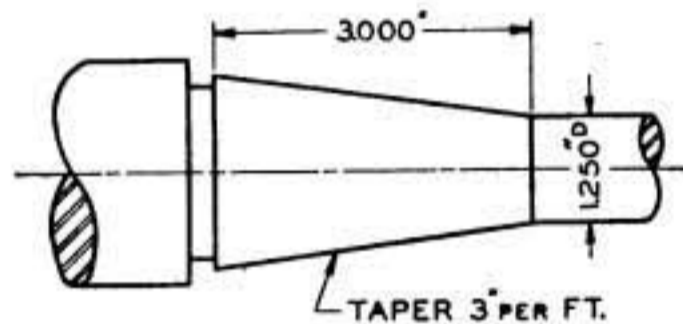

FIGURE 80.—Dimensioning special taper.

drawings. Notes may include such information as finish, fit, material, number of parts required, etc.

(2) When a note is required to indicate an operation, it is often convenient to include dimensions in the note, such as the diameter and depth of holes when drilling or reaming operations are called for.

(3) Notes of general character which do not require leaders to indicate where they apply may be located to the left of a title block. These notes may be placed one above the other, each note to be numbered beginning at the bottom, and bracketed if the note contains more than one line.

(4) Notes of local character, such as drill notes, thread notes, etc., which apply to parts of drawings which must be indicated, are located at such places that leaders may be taken from the top line of the note to the part. The arrowhead of the leader should touch one of the boundary lines and not an indefinite point inside the part or area affected by the note.

(5) If a note refers to more than one hole or place, leaders should indicate each, unless they are so located that the application of the note is clear without the leader. A leader should indicate at least one of the group. The note should indicate how many places are affected by

it, when leaders do not indicate each place. On large complicated drawings, the following system may be used for showing the relation between notes and the places affected:

(a) The note may be located in any convenient space on the drawing. When more than one note of this character is used, they may be placed one below the other. An identifying letter, known as the note letter, is placed within a small circle or triangle at the beginning of the note.

(b) If the places affected are irregularly located, the note letter may be located at each place or so located that leaders may lead from it to the various places. If the places affected are in groups, one note letter may indicate one place in each group, and the number of places in the group may be noted after the circle or triangle, as

Ⓐ (or ▲) 6 holes.

(c) When the same note letter is used more than once, the number of letters (not the number of places affected) is shown in the note, as

Ⓐ (or ▲) Drill $\frac{5}{16}$.
 Depth $\frac{1}{2}$
 4 letters

b. (1) To provide for an allowance of material so that a surface may be machined or otherwise finished, the symbol *f* is placed across the line which represents such surface on each view. The required finish may also be in the form of a note at the view, or be included in the finish nomenclature. If all surfaces are to be finished, a note specifies "Finish all over" or F. A. O.

(2) The American Standard Association recommends that a surface to be machined or finished from unfinished material, such as a casting or forging, should be marked with a 60° "V," the bottom of the "V" touching the line representing the surface on the drawing. A code figure or letter should be placed in the "V" to indicate the quality of finish desired. The meaning of the code figures or letters should be indicated by notes at the bottom or side of the drawing.

(3) On Army Air Forces drawings, various grades of finished surfaces are called for by placing an identifying numeral in the small circle of the finish symbol $\odot f$. This symbol is placed on the drawing in the same manner as the customary *f* symbol.

SECTION IX

TECHNICAL SKETCHING

Paragraph

Technical sketching----- 48

48. Technical sketching.—*a.* Technical sketching is accomplished freehand. Information from which the usual working drawing is to be made is frequently issued to the draftsman in the form of freehand sketches. Also, the draftsman may find it advantageous to resort to freehand technical sketching when making a drawing of an object already in existence. A technical sketch properly dimensioned may serve as a working drawing in some instances.

b. Technical sketching may be done with a 2H, H, or F pencil sharpened to a slightly blunt conical point. The pencil is held similar to the manner in which it is held for writing but with the fingers

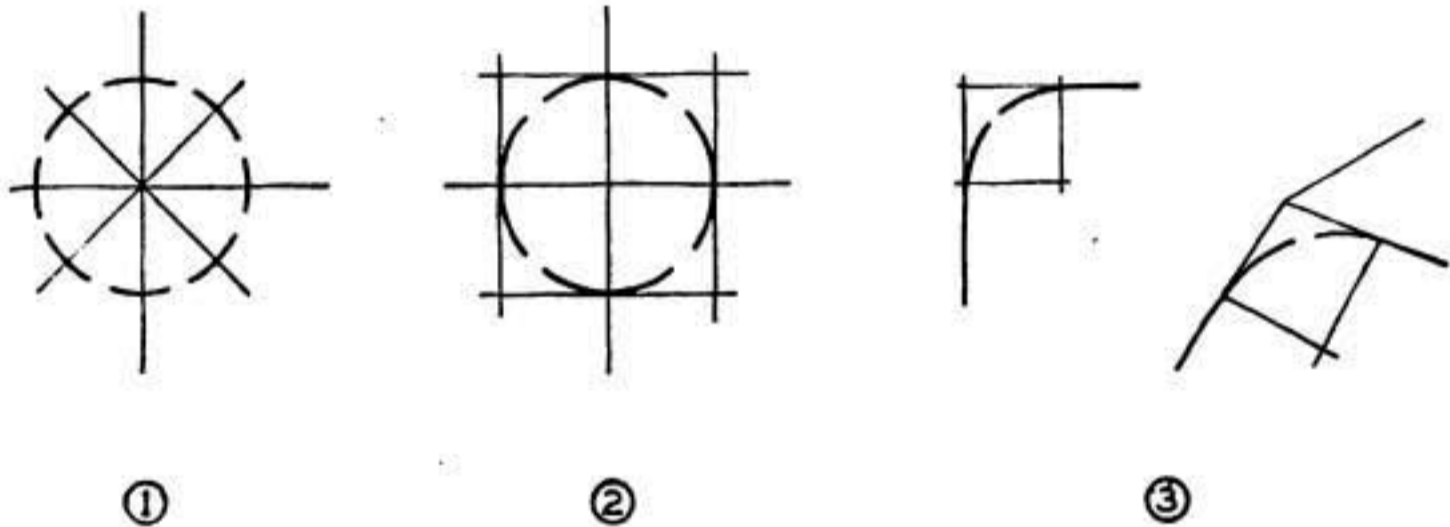

FIGURE 81.—Sketching circles and arcs.

moved up and away from the point. The important feature is to draw the lines in the direction intended; a reasonable amount of waviness in the line will generally result, but this is not objectionable. Rather than draw a long line solid for its full length, it may be advisable to use pencil strokes of approximately 1 inch in length, continuing the line with even pressure from each break. Cross-section paper may be used, although unruled paper will serve better to perfect line work and estimation of proportions.

(1) Horizontal lines are sketched from left to right with a free movement of the wrist or forearm.

(2) Vertical lines are sketched downward with a finger movement.

(3) Lines inclined downward from right to left are drawn in the same manner as vertical lines. Those inclined downward from left to right may be more easily accomplished by turning the paper so that they may be drawn in a horizontal position.

(a) A circle may be accomplished by laying off the radius at four places on the vertical and horizontal center lines and sketching the circle through these points (fig. 81①). More points may be obtained by drawing oblique center lines and laying off the radius in four places, so that a total of eight points in all will result. A circle may

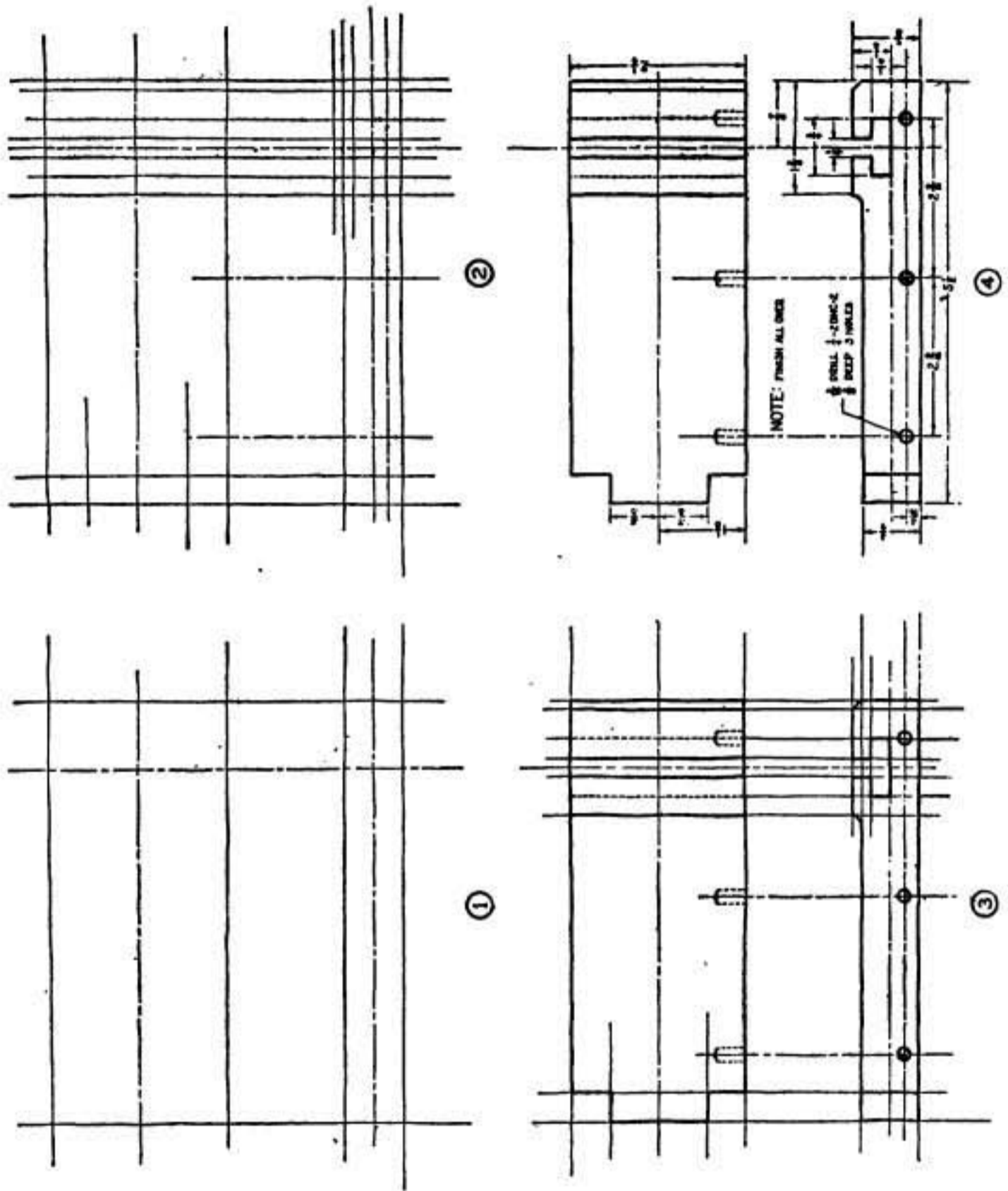

FIGURE 82.—Orthographic sketch.

also be drawn in a square with sides equal to the diameter, and the circle tangent to the sides of the square at the vertical and horizontal center lines (fig. 81②).

(b) Arcs may be accomplished by drawing tangent to the blocking lines (fig. 81③).

o. (1) When executing an orthographic (or pictorial) sketch, the proportions of the object are judged by eye. The various features of the object may be advantageously compared for purpose of determining size.

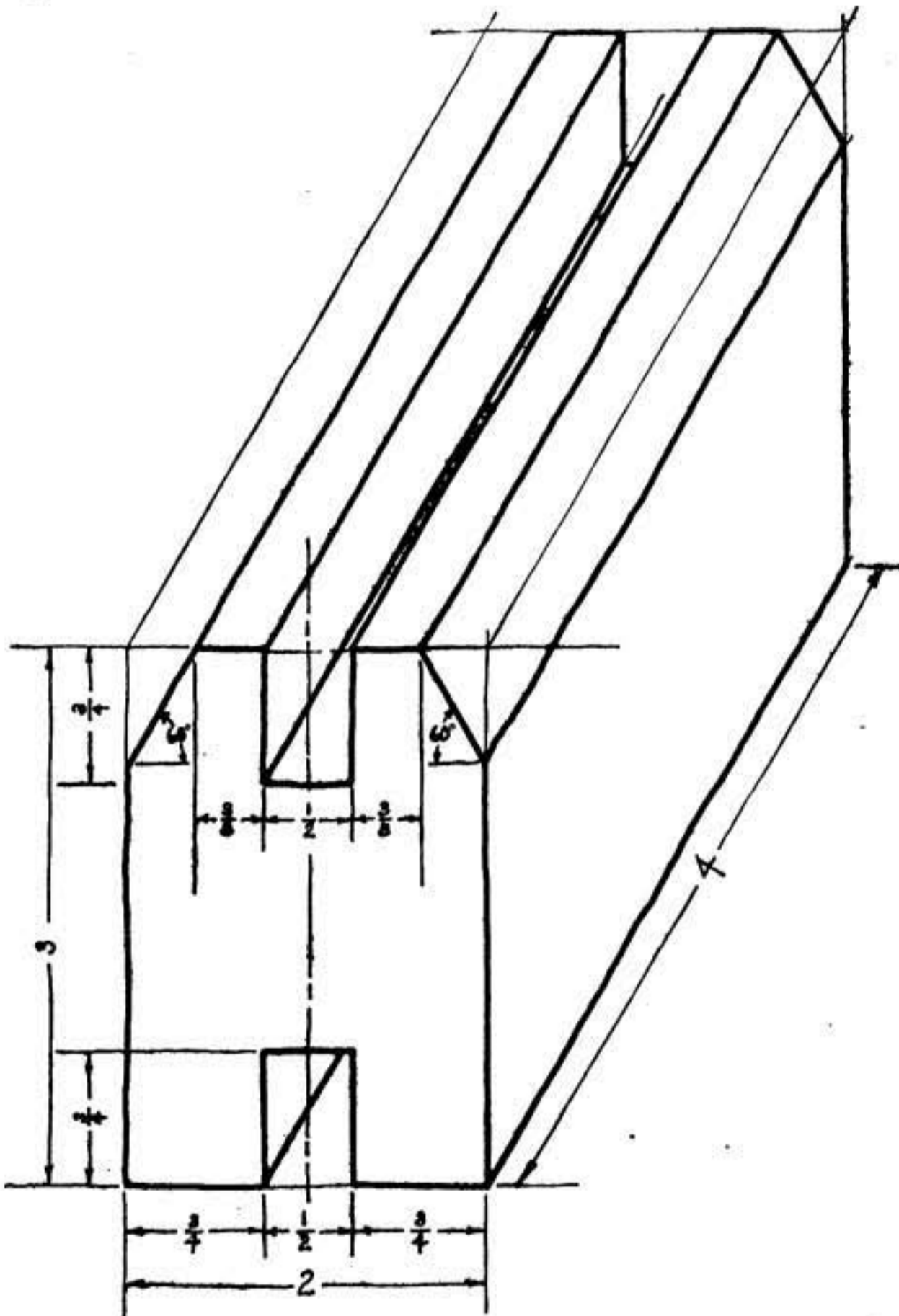

FIGURE 82.—Pictorial sketch.

(a) After the center lines are located, the general proportions of the object in the various views are blocked in with inclosing straight lines (fig. 82①).

(b) The various features of the object are then blocked in (fig. 82②) and the sketch finally completed (fig. 82③). Dimensions,

notes, and other details are added to complete the drawing (fig. 82④). As in regular drawing, sectional views should be used, when necessary, to reveal interior construction.

(2) A pictorial sketch may serve to convey information to those who may experience difficulty with orthographic views. Pictorial sketches are executed freehand in accordance with the principles set forth in section VI. A pictorial sketch is shown in figure 83.

SECTION X

SHEET METAL DRAFTING

	Paragraph
General	49
Parallel line development.....	50
Radial line development.....	51
Development by triangulation.....	52

49. General.—*a.* (1) Sheet metal drafting, or the development of a surface, is the process of laying off a given area on a flat surface so that the resulting figure can be shaped correctly into the desired object. This procedure may be illustrated by wrapping the sides of an object tightly with a piece of paper cut to the right size to cover the surface of the object exactly and then unrolling or unfolding the paper into a perfectly flat surface. Figure 84① and ② shows a cylinder and cone, respectively, in the process of development. The outline which the paper presents is called the development of the surfaces which it covered. Therefore the development of the outside surfaces of an object will be a true envelope of the object laid out on a plane. In practice the terms “lay-out,” “stretch-out,” and “pattern” are used interchangeably with the term “development.”

(2) Another way to illustrate the development of a surface is by taking a cube made from cardboard and cutting it in such a manner that it will unfold to a flat surface that may be readily returned to the original shape of the object (fig. 85).

(3) In the development of surfaces, sufficient material should be allowed for overlap at seams.

b. When a number of geometric solids of different forms are considered, some can be wrapped closely and some cannot; for example, a sphere or ball cannot, because the surface is curved in more than one direction, whereas, in the case of a cylinder or cone, the curve is in one direction, and the paper will fit closely. Therefore any surface that can be wrapped smoothly with a thin, flexible material, that is, any surface composed of planes or single curved surfaces, is developable; any surface that has double curves is theoretically

undevelopable; however, such patterns may be approximated closely enough for practical construction.

c. Development problems resolve themselves into three forms: parallel line development, radial line development, and triangulation. The form to use depends upon the shape of the object to be developed.

50. Parallel line development.—Objects which have opposite lines parallel to each other, or which have the same cross-sectional shape throughout their length, are developable by this method. This includes such objects as the cylinder and prism and their many variations.

a. Hexagonal prism.—Figure 86① shows the hexagonal prism in pictorial form. The object is also represented unrolled to show its

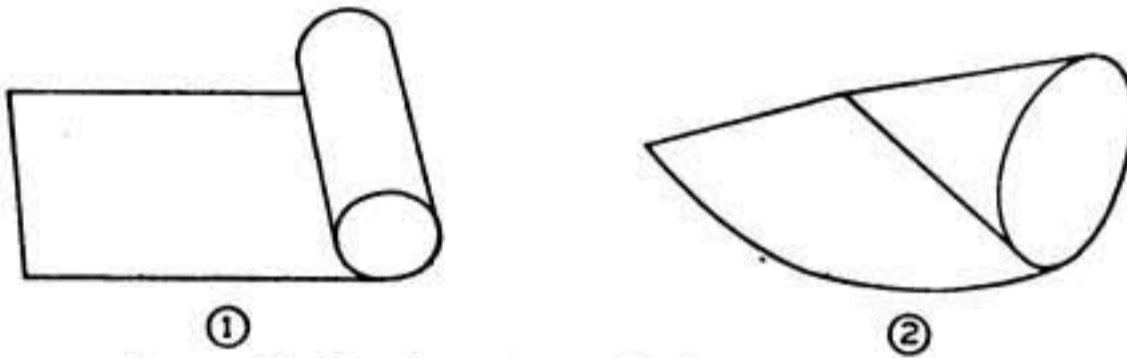

FIGURE 84.—Development of cylinder and cone.

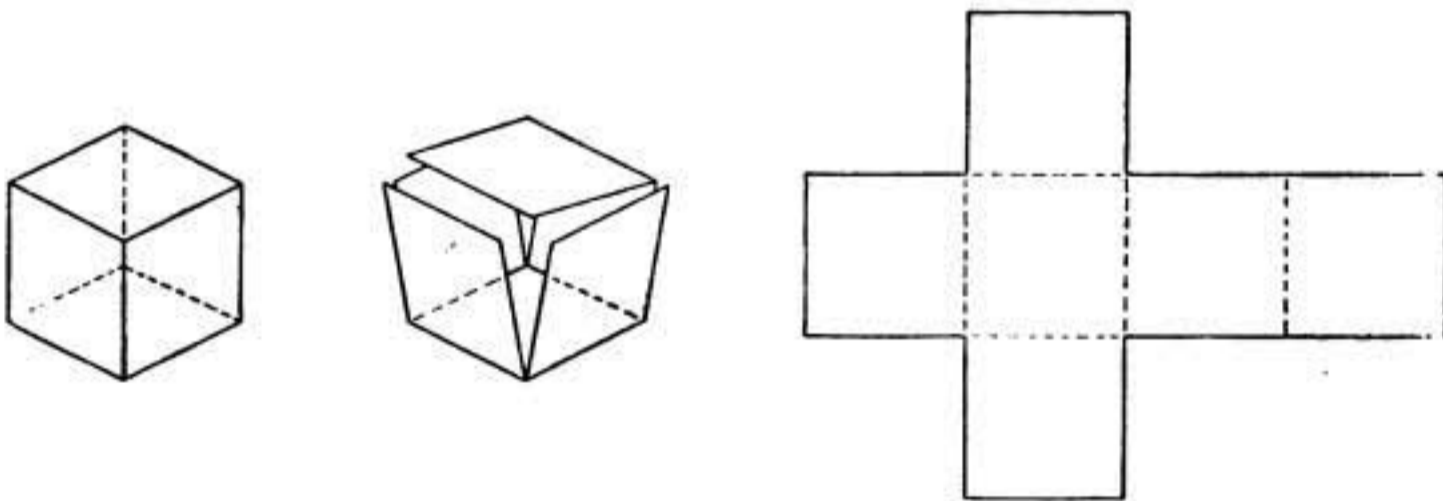
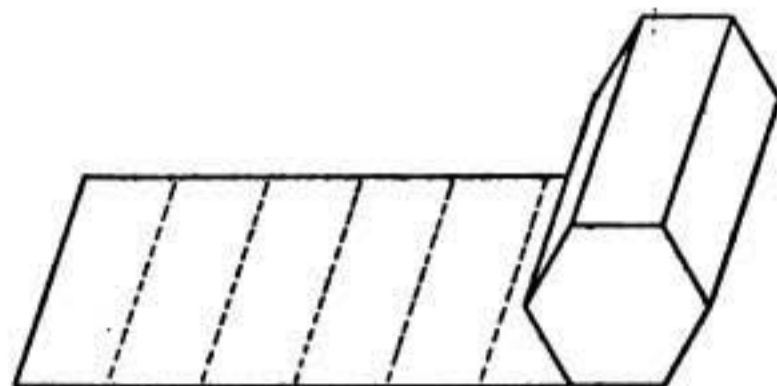

FIGURE 85.—Development of cube.

outside surfaces in a flat, continuous plane. Figure 86② shows how the pattern is produced when the conventional two-view drawing is given. A line *AB* of indefinite length is extended from the base of the side view at right angles to its vertical axis. On this line six spaces are stepped off equal to the width of each of the vertical faces of the prism. The distance thus laid off is equal to the perimeter of the hexagon and is called the “stretch-out” line. The stretch-out line is taken to mean the perimeter of a right section (a section cut by a plane perpendicular to the edges or elements). At the points stepped off on the stretch-out line, perpendiculars are erected equal to the height of the prism as given in its elevation view. This is readily accomplished by projecting the line *CD* from the top of the

elevation, parallel to the line AB . Each of the perpendicular lines (edges or elements) is numbered 1, 2, 3, etc., to correspond with the numbers of the angles of the top view. The perpendiculars drawn from AB to CD represent the elements of the prism when it is formed to shape. The top and bottom of the prism are developed by attaching the plan outline to any of the faces between two elements.

b. Hexagonal elbow.—Assume that the hexagon is cut off at 45° and the two pieces are used to form halves of a 90° hexagonal elbow.



①

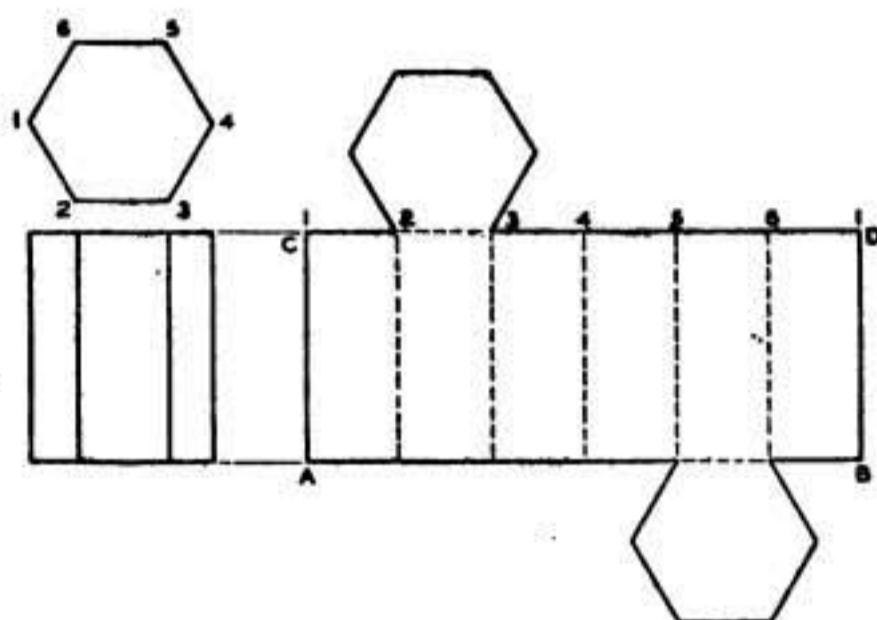

②

FIGURE 86.—Development of hexagonal prism.

Draw the side and top views (fig. 87) and project a horizontal line AB , indefinite in length, out from the bottom of the side view. With the dividers, step off the width of the sides on the horizontal line. From each division point on the horizontal line draw ascending vertical lines of indefinite length. Drop vertical lines from the points of intersection of the sides in the top view, down across the 45° angle in the front view. From the points of intersection thus located on the angle in the front view, project horizontal lines across to intersect the vertical lines which were drawn up from line AB . Connect these points of intersection by straight lines which will give the outline of the top

of the pattern for one-half of the elbow. Only one-half of the elbow is developed because the patterns of the two parts are the same.

c. Right cylinder.—(1) A right cylinder has its lateral edges or elements perpendicular to the plane of the base. The width of the pattern of the cylinder shown in figure 88① is the same throughout its length, corresponding to the length of the cylinder; the length of the pattern (stretch-out) is equal to the distance around the base (circumference) of the cylinder.

(a) The circumference of the cylinder bears a definite ratio to the diameter (3.1416 to 1). For example, if a cylinder with a 3-inch diameter is given, the circumference will be $3 \times 3.1416 = 9.4248$. The fractional equivalent on the measuring scale is chosen to approach most nearly the value of the decimal fraction.

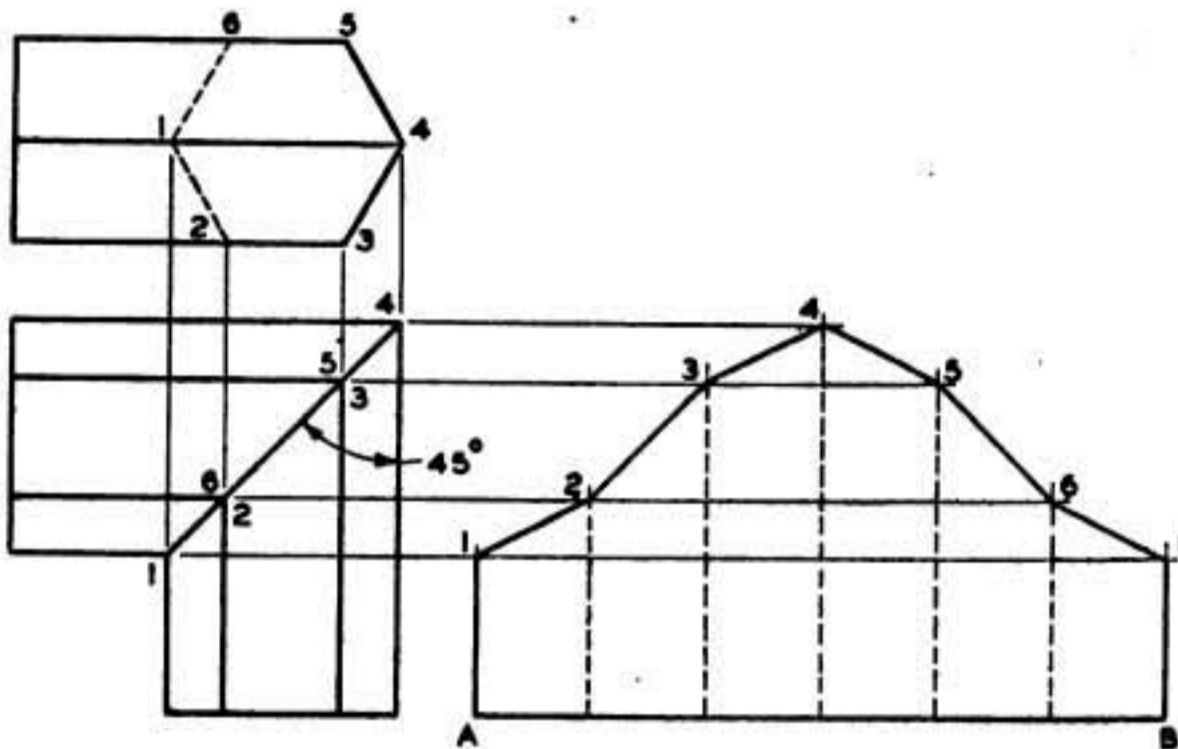

FIGURE 87.—Development of 90° hexagonal elbow.

(b) The length of the pattern may also be obtained as follows: Lay off a small angle on the circle, which angle is contained in the circumference an equal number of times. The length of the pattern will more nearly approach the true circumference as the size of the angle is decreased. Set the dividers to the distance between the points where the sides of the angle cut the circle, and transfer the stepped-off distances from the plan view to the stretch-out line. The accuracy in the length of the pattern line may be tested by measuring it and comparing it to the figured length of the circumference of the circle ($3.1416 \times D$).

(2) (a) Assume that the cylinder (fig. 88②) is cut off at an angle (truncated). Draw the side and top views, and project a horizontal line *AB*, indefinite in length, from the bottom of the side view. Divide the top view into a number of equal angles. Set the dividers equal to the distance between the points where the sides of the angle cut the

circle, and step off on the horizontal line *AB* as many spaces as there are angles in the top view. From each division point on the horizontal line *AB*, draw ascending vertical measuring lines of indefinite

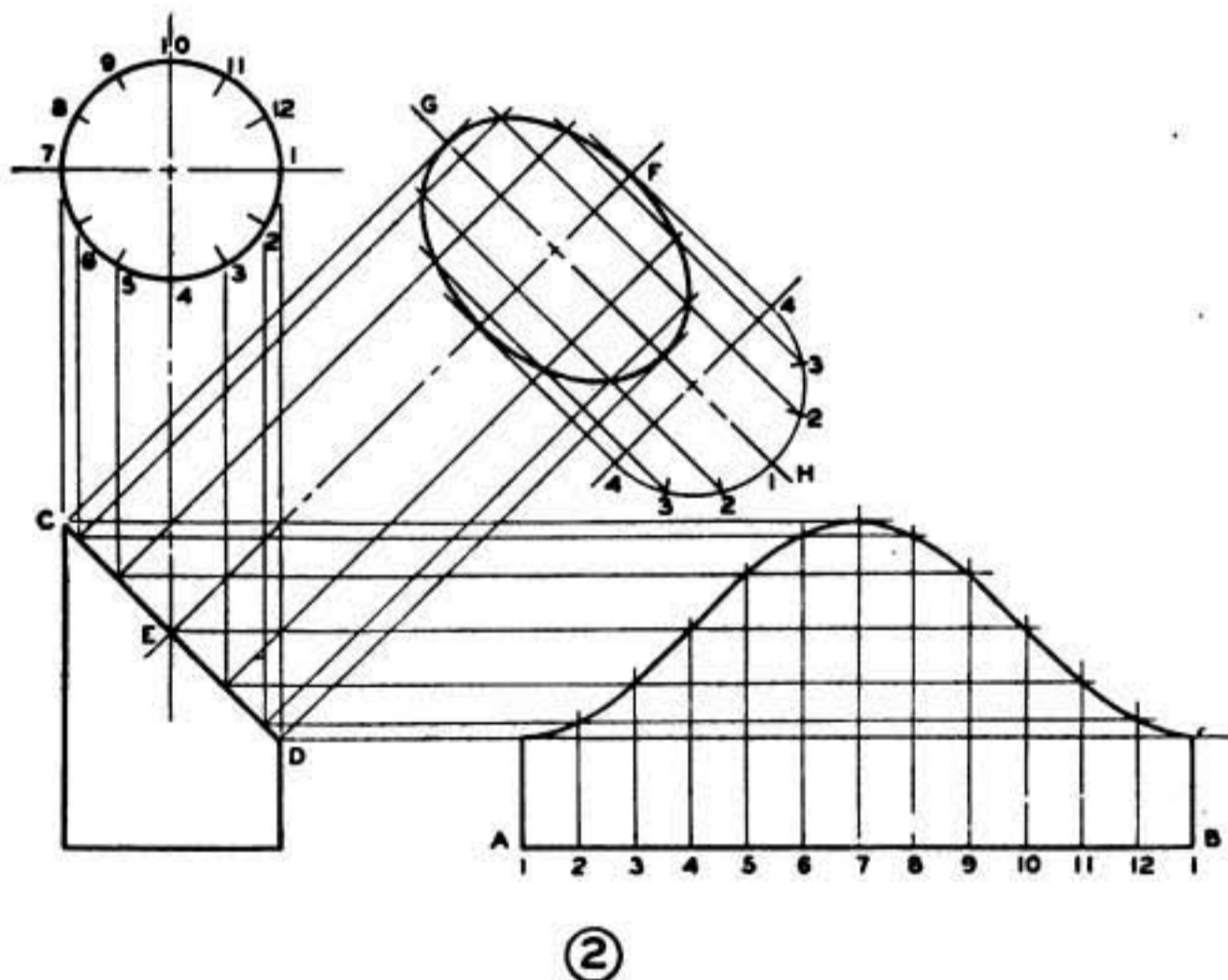
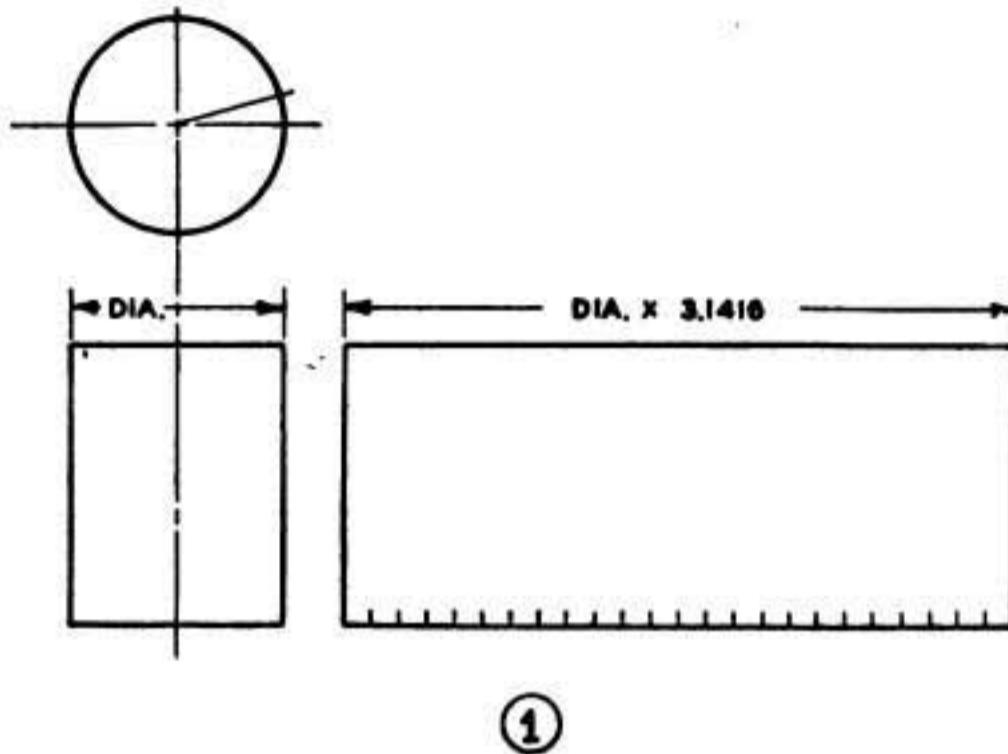

FIGURE 88.—Development of right cylinder.

length. Drop vertical lines from the top view down across the angle in the side view, and from each point thus located, project horizontal lines across to intersect the vertical measuring lines. Connect these points with a smooth curved line to form the pattern of the cylinder.

(b) To obtain the shape of the surface CD as it would appear in the auxiliary view, draw a center line EF at right angles to CD , and through EF draw center line GH parallel to CD . On GH draw a half profile of the top view. On the semicircumference, step off like divisions as on the top view. Project lines parallel to GH which intersect the corresponding lines from CD to locate the points of the auxiliary view (ellipse).

51. Radial line development.—*a. General.*—Surfaces developable by this method are those which are conical and those in the shape of pyramids, that is, surfaces converging to a point. The pyra-

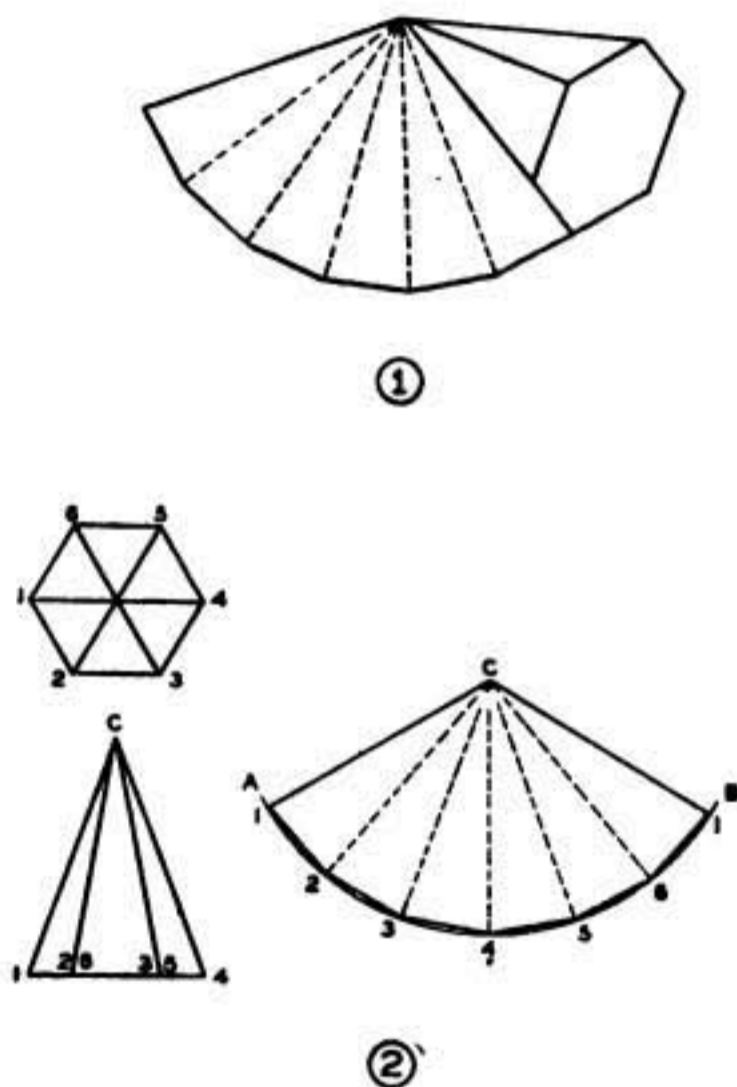

FIGURE 89.—Development of right pyramid.

mid has flat sides which give it a base in the form of a polygon. If it has four flat sides at right angles to one another, it is called a rectangular pyramid; if it has six sides, it is called a hexagonal pyramid, etc. The cone has a circular base; the cones considered in this paragraph are those in which the apex is directly above the center of the base (right cone).

b. Right pyramid.—The shape of the pattern for a right pyramid (axis perpendicular to base) may be illustrated by holding the apex of a pyramid at a definite point and rolling the pyramid as illustrated in figure 89①, the outline of each surface of the pyramid being imprinted upon the surface over which it is rolled. The pattern thus

obtained converges to a point, and all the elements are equal in length. Figure 89(2) illustrates the radial line method of developing such a pattern. The two views provide the necessary shape description and dimensions. All edges are numbered correspondingly in both views. The apex of the pyramid is taken at center C , and an arc AB is drawn, indefinite in length, with the length of an outside edge of the pyramid as a radius. Although all the edges are equal, they do not appear so in elevation because of the inclined surfaces. Thus only the outside edges show the true lengths for use as the radius of the arc. A point is selected on the arc for the first element. With the dividers set to a distance equal to the length of a side of the base, the other elements are stepped off around the arc. The points located in this manner are then connected with straight lines to form the outline of the pattern. Lines are drawn from these points to the center point to show clearly where the folds will be made when the object is brought to shape.

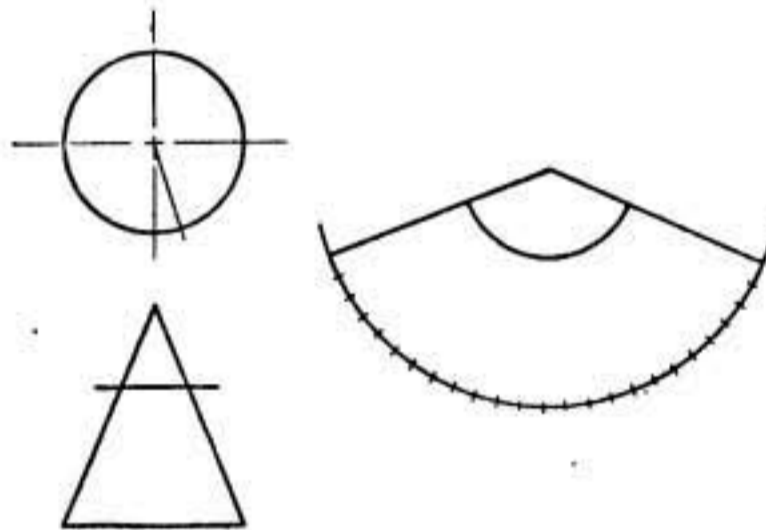

FIGURE 90.—Development of right cone.

c. Right cone.—The pattern of the right cone (fig. 90) is a portion of a circle, the radius of which is equal to the slanting height of the cone. One edge of the pattern must be equal to the distance around the base of the cone; therefore this distance is laid off on the circumference of the pattern circle. To do this the approximation method, as described in paragraph 50c(1)(b), is used. The end points of the distance laid off with the center of the circle are connected, and the pattern is complete. Should it be desired to cut a portion of the cone away on a line parallel with the base, the slanting height of the small cone thus formed is taken as a radius and an arc swung on the pattern using the original center point. When the pattern is cut out, the two straight sides are brought together to form the cone.

(1) The surface development of a truncated pyramid (fig. 91) is similar to that for the whole pyramid, with the exception that now the elements are no longer the same length. A two-view drawing is

made to provide the necessary shape and dimensions. The elevation view must be completed by construction lines to locate the apex of the pyramid, but it is not necessary to complete the top view in all details. The outline alone provides the required information. The top view shows the base outline of the pyramid, thus giving the side widths. As a starting point for the pattern, a center is located. A complete pattern for a whole pyramid is then laid out as in the problem in *b* above. On the pattern are laid off the true lengths of the elements. Suppose the pattern begins at the shortest element. The true length of this element is seen in the elevation view. By means of dividers, this length is transferred to element 1 on the pattern. Considering element 2, the elevation does not show its true length, as it is inclined to the plane of projection. To find its true

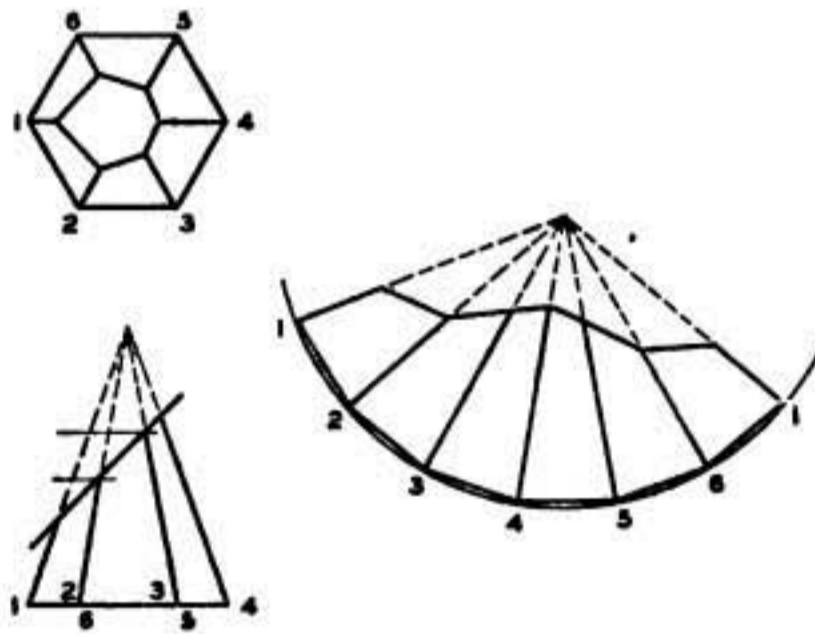

FIGURE 91.—Development of truncated pyramid.

length, it is imagined that the pyramid is revolved about until this edge is in the position of element 1, where its true length can be seen. To accomplish this, a horizontal line is drawn from the upper end of element 2 until it crosses element 1. The true length of element 2 is the distance from this intersection point to the lower extremity of element 1. The true length of element 3 is found in the same manner. Element 4 is shown in its true length. This completes half of the pattern; the other half is the same.

(2) The pattern for the truncated cone shown in figure 92 employs the same general procedure as outlined for the complete cone. The elements are extended until they meet in order to find the radius of the pattern arc. The circumference of the cone base is laid off on the arc by the approximation method previously described. Connect each of the divisions with the center of the pattern. Step off the lower half of the circle in the top view with the same division. From the points thus located on the circle, project vertical lines down until

they cross the base line of the cone in the elevation view. From these points of intersection, draw lines toward the apex of the cone until they cross the oblique line indicating the top of the truncated cone. These lines are the elements that correspond to those which have been laid out on the pattern. To find the true length of each line on the elevation view, project a horizontal line from each point on the oblique line until it cuts the true length element of the cone. These horizontal lines will cut off lengths equal to the true lengths of the lines. It is advisable to number corresponding elements on both views and the pattern to facilitate the transfer of the true lengths from the elevation view to the pattern.

52. Development by triangulation.—*a. General.*—It frequently occurs in development problems that the orthographic views of the

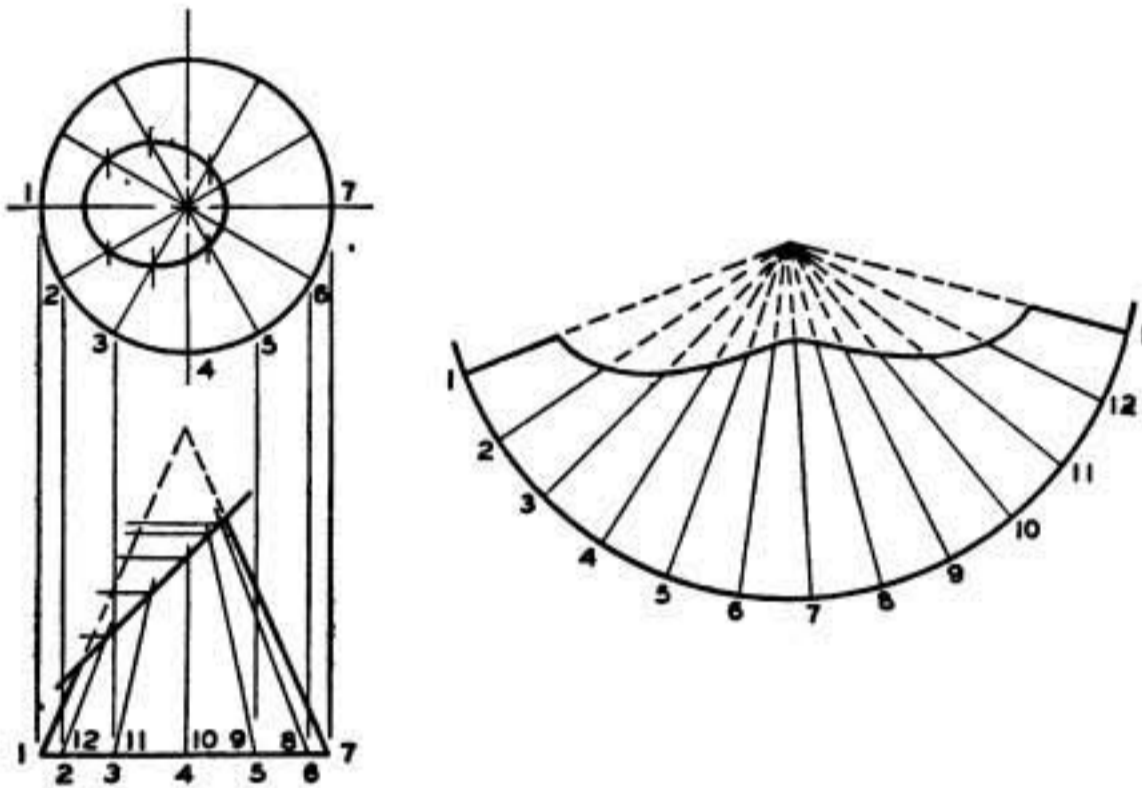

FIGURE 92.—Development of truncated cone.

object do not show the true dimensions of surfaces which must be included in the pattern. Such a case is found in the truncated pyramid shown in figure 91, in which certain elements are not shown in their true lengths because of their inclined positions. Since all elements of a right cone are equal in length, the true lengths of the foreshortened lines may be found by revolving the object on a vertical axis until the line, or element, reaches a position on the drawing which shows the true length of the element. This is accomplished on the drawing by projecting a horizontal line from the upper end of the element out to the side of the cone. This line cuts off on the element shown in its true length a distance equal to the true length of the foreshortened element. In development by triangulation, the inclined element is imagined to be the hypotenuse of a right triangular section,

the base of which is the radius of the base of the cone, and the altitude the vertical height; this triangle is then revolved until the hypotenuse is parallel to the plane of projection, thus showing its true length. It follows that triangulation is based upon the use of the right triangle in determining the true lengths of lines, real or assumed, upon the surfaces to be developed. In some cases it is necessary to show the elements in two views as a basis for finding their true lengths. An elevation view shows the vertical height of an element, and a plan or top view shows the horizontal distance covered by the same element. Then if these two distances are laid off as the sides of a right triangle, the hypotenuse of the triangle shows the true length of the element.

b. Oblique cone.—For an application of the theory discussed in *a* above, the surface development of an oblique cone (fig. 93) will be used.

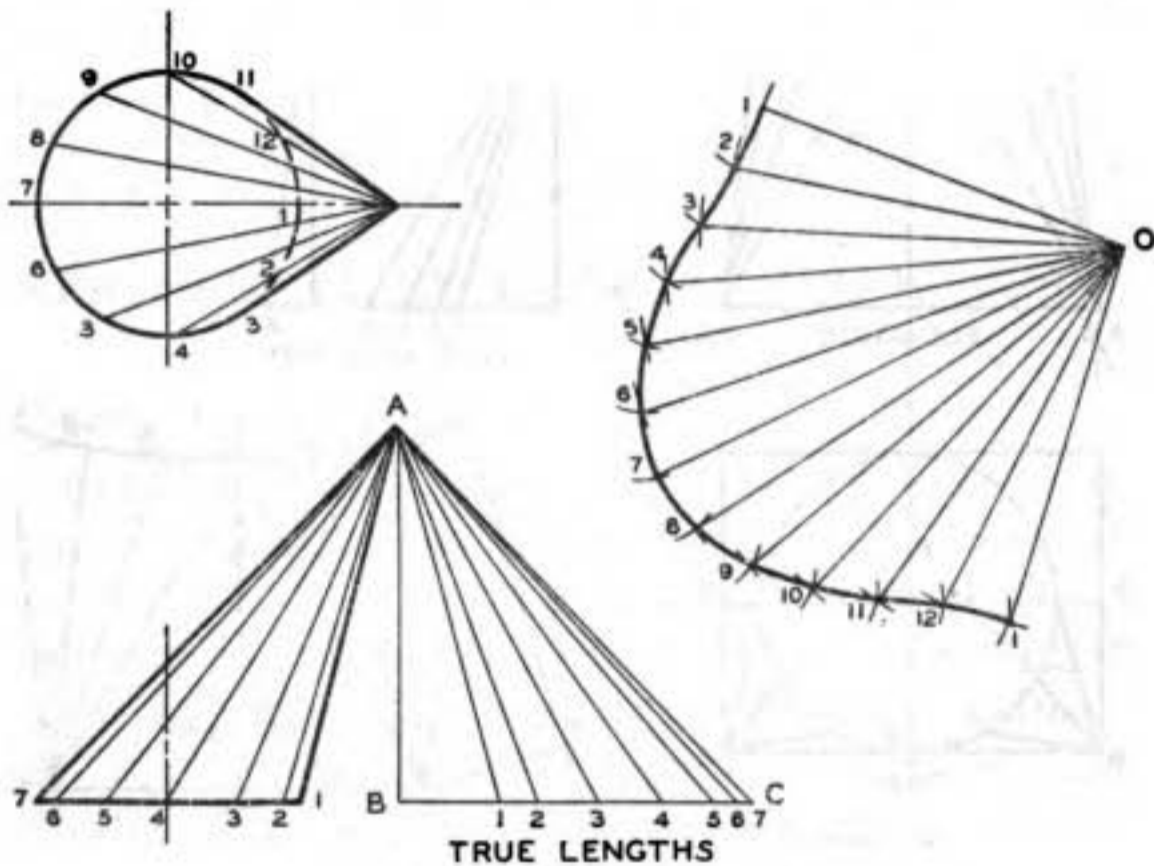

FIGURE 93.—Development of oblique cone.

(1) The elevation and plan views are constructed and divided into elements. In the elevation view, the short side (*A1*) of the cone shows the least width (*01*) on the pattern, and the long side (*A7*) shows the greatest width (*07*) on the pattern. These two lines correspond to the elements which fall on the horizontal center line in the plan view. It is thus shown that any element line which is horizontal in the plan view shows its true length in the elevation view.

(2) In the elevation view the vertical distance (*AB*) from the vertex of the cone to the base line is the vertical height of all elements, and the lengths of all elements, as shown in the plan view, are laid off at right angles to this vertical height distance (*AB*) along *BC*. The

hypotenuse of each of the triangles thus formed is the true length of the element to which it corresponds.

(3) In forming the pattern, a center point is first located. A line is drawn from this point equal in length to the short side of the cone to form one edge of the pattern. With the dividers set to a radius equal to the distance between elements as shown in the plan view, and using the outer end of the line as a center, a short arc is drawn. Then with the dividers set to the true length of the element adjacent to the short side, and the pattern center point as a center, an arc is drawn to intersect the first arc. This intersection point will be a point on the outline of the pattern. With the dividers again set to the first radius and with the intersection of the preceding arcs as a center, another

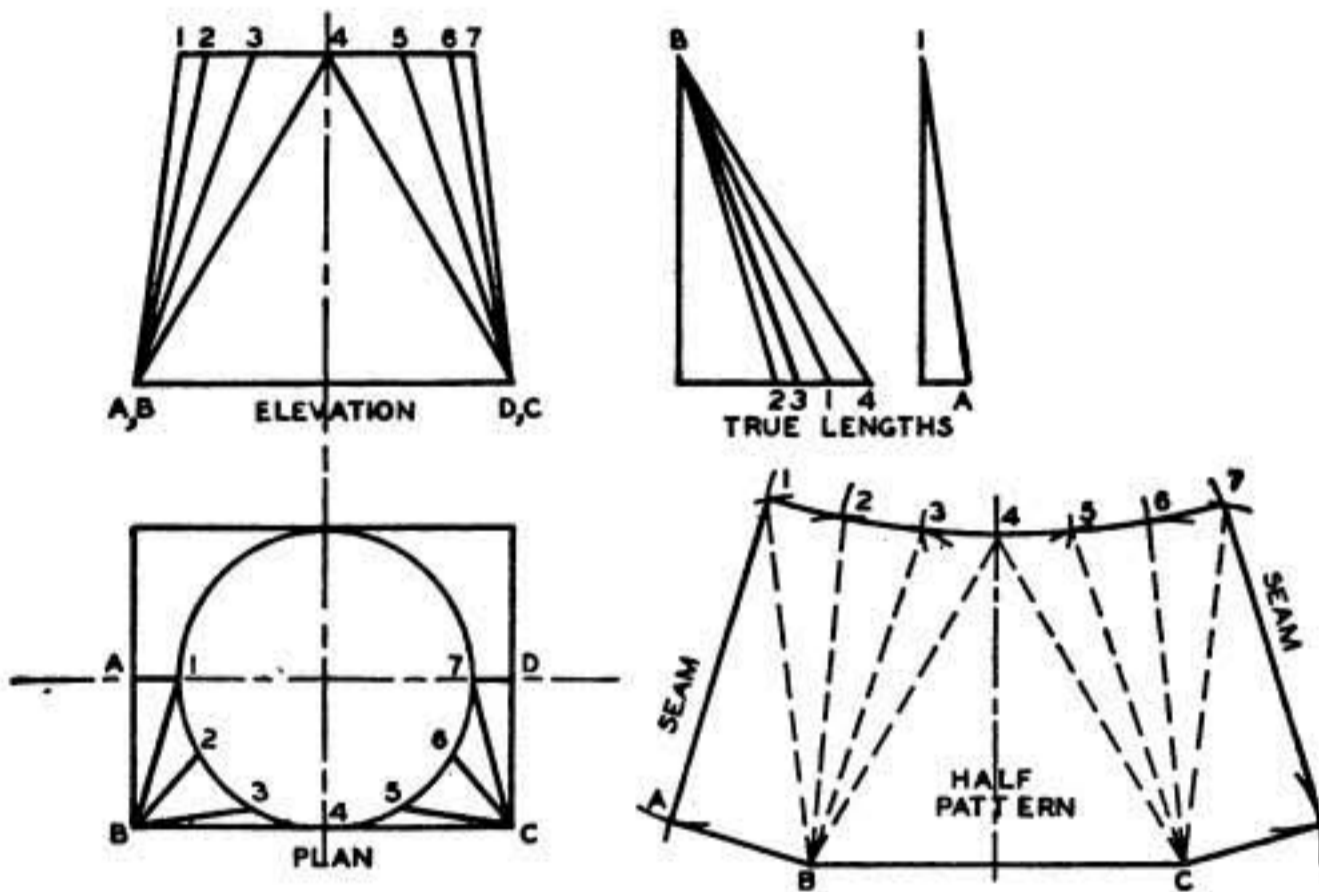

FIGURE 94.—Development of transition piece.

arc is drawn; the true length of the next element is swung to intersect it, thus locating another point on the outline of the pattern.

(4) This procedure is continued until the true lengths of all elements have been laid off. The arc intersections are then connected with a smooth curved line to complete the approximation.

c. Transition piece.—Figure 94 shows the development of a transition piece suitable for forming a connection between cylindrical and rectangular ducts. The diameter of the circle end is equal to the length of the shorter side of the rectangular end. A half pattern only is shown, therefore, two pieces should be cut out to this shape. Element lines are constructed, correspondingly, on both the elevation and plan views as a basis for finding their true lengths. The plan is drawn as a bottom view. To start the pattern, a triangle $B-A-C$ is

laid out the same as the triangle in the elevation view which bounds the flat part of the surface. Note that this flat surface is parallel to the plane of projection in the elevation view and therefore its true shape is shown. The distances between elements 1, 2, and 3, etc. in the pattern are the same as the distances between them in the plan. These distances should be laid off one at a time by drawing an arc each time. The true lengths of numbers 1, 2, and 3 are swung from B to intersect the smaller arcs. Numbers 5, 6, and 7 are likewise swung from C . The pattern should be started from the center and developed out each way to the sides. When point 7 is located on the pattern, the dividers are set to the true length of $7D$, which is shown in the elevation, and with point 7 on the pattern as a center, an arc is swung. Then with CD on the plan as a radius, and C on the pattern as a center, another arc is swung to intersect the first, thus locating D on the pattern. Point A is located in a similar manner, thus completing the outline of the half pattern.

SECTION XI

REPRESENTATIVE WORKING DRAWINGS

	Paragraph
Assembly and detail drawings.....	53

53. Assembly and detail drawings.—Drawings are divided, generally, into two classifications: assembly drawings and detail drawings.

a. (1) Assembly drawings show all parts of an object in their proper position and relation to one another. Only principal dimensions dealing with assembly and installation are given. Invisible outline is omitted unless required for clarity. Figure 95 shows an assembly drawing of a vise.

(2) Subassembly drawings are drawings which show several details assembled in their working order, but are only a part of the main assembly. An example of such a drawing is the screw assembly (fig. 96), which in itself is a working unit requiring assembly with other units to make a complete assembly of the vise. Subassemblies are frequently shown in section to indicate more clearly the relation of the various details in the assembly. Subassembly drawings have a part number, which is the number applied to that particular combination of details. Subassemblies have the details designated with their proper part numbers.

(3) Frequently, if the object involves no complicated details, an assembly drawing may suffice to present complete information and may thus be used as a working drawing.

b. A detail drawing carries the minutest detail pertaining to the construction of each component part of the assembly. The detail drawing includes specifications of materials, dimensions, shop notes, changes, part numbers, finish, number of pieces required, and other

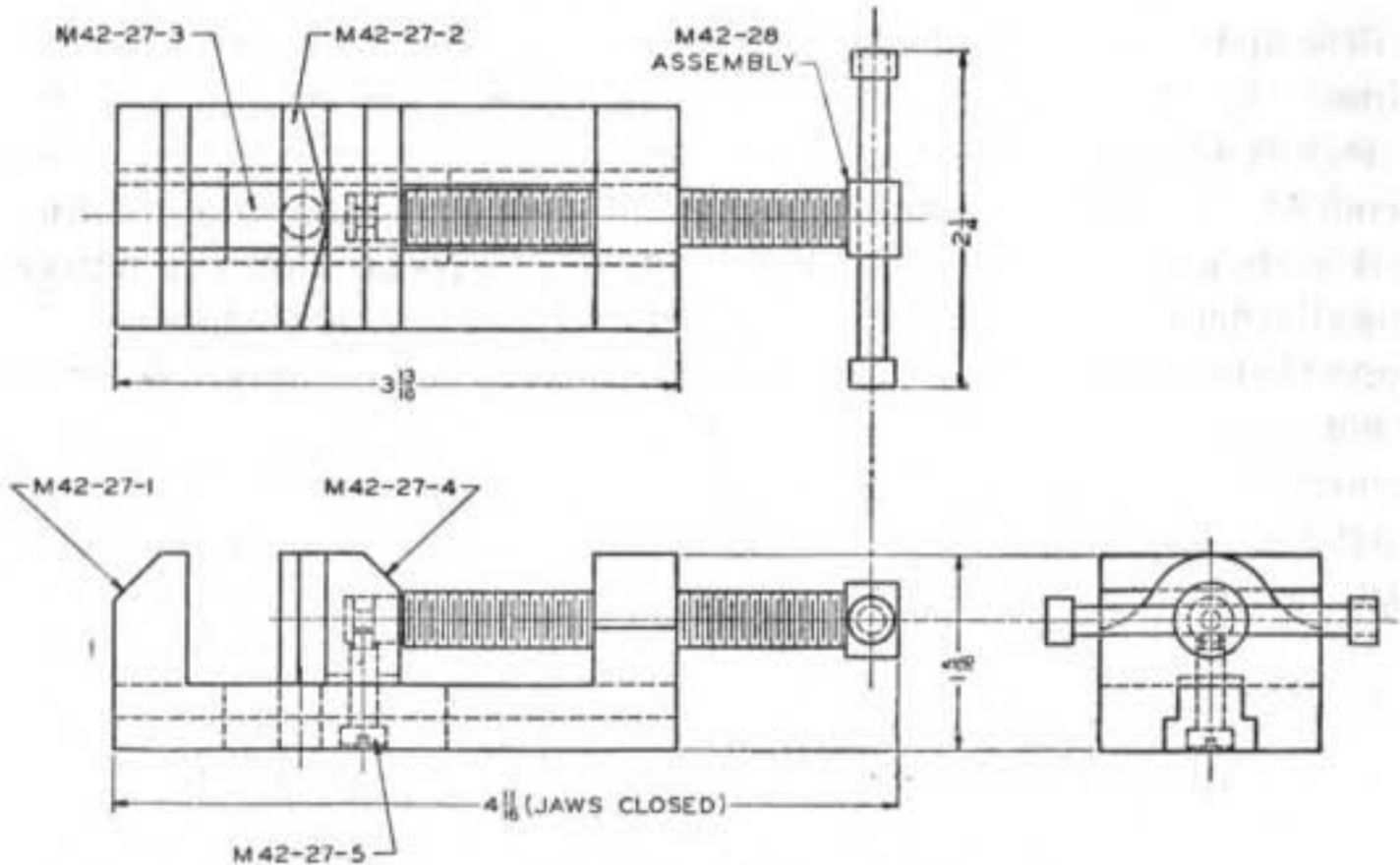

NOTE.—Limits on dimensions $\pm .0075$ unless otherwise specified.

FIGURE 95.—Assembly drawing of vise.

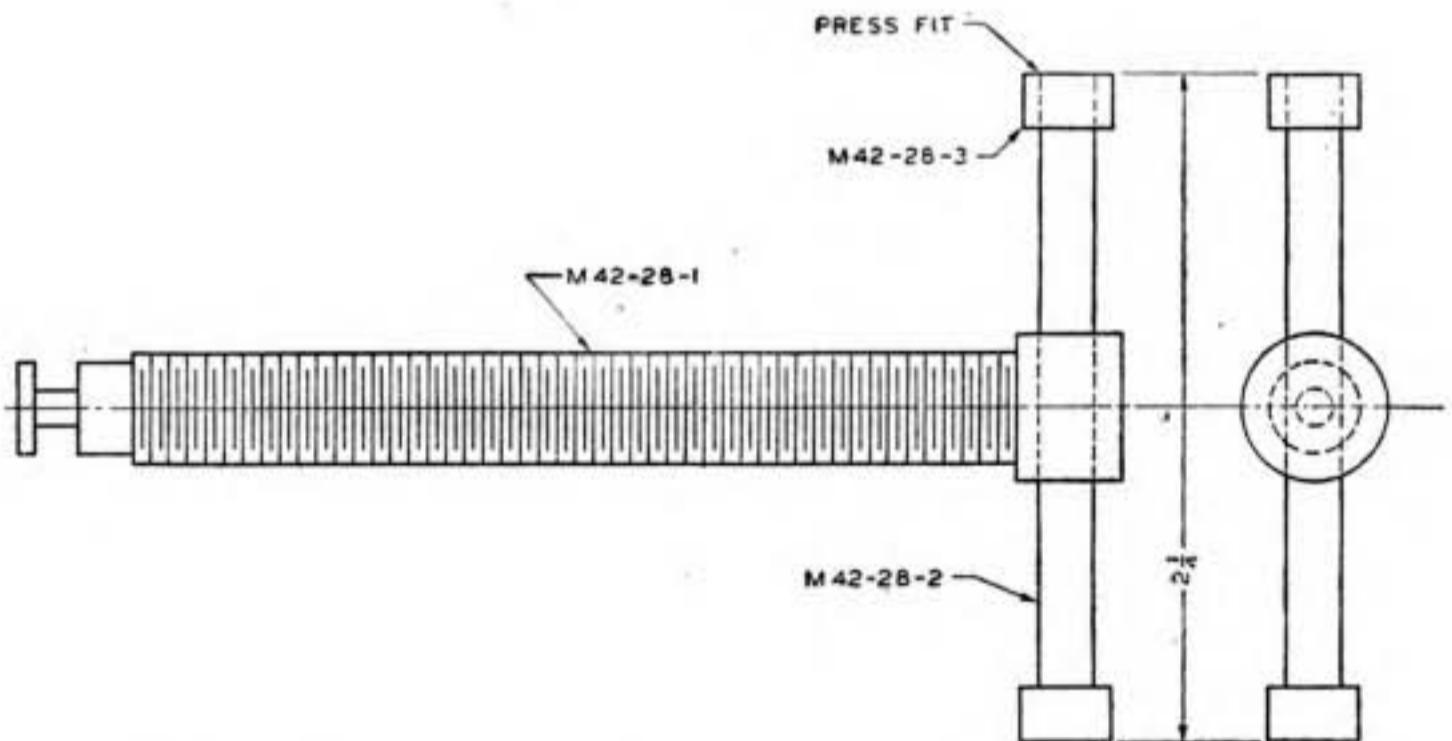

NOTE.—Limits on dimensions $\pm .0075$ unless otherwise specified.

FIGURE 96.—Assembly drawing of screw.

information relative to the construction of the object, thus affording a complete picture of the part. Detail drawings of the component parts of the vise, such as the base, swivel jaw, guide, jaw, retaining screw, screw, handle, and collar are shown in figures 97 to 104, inclu-

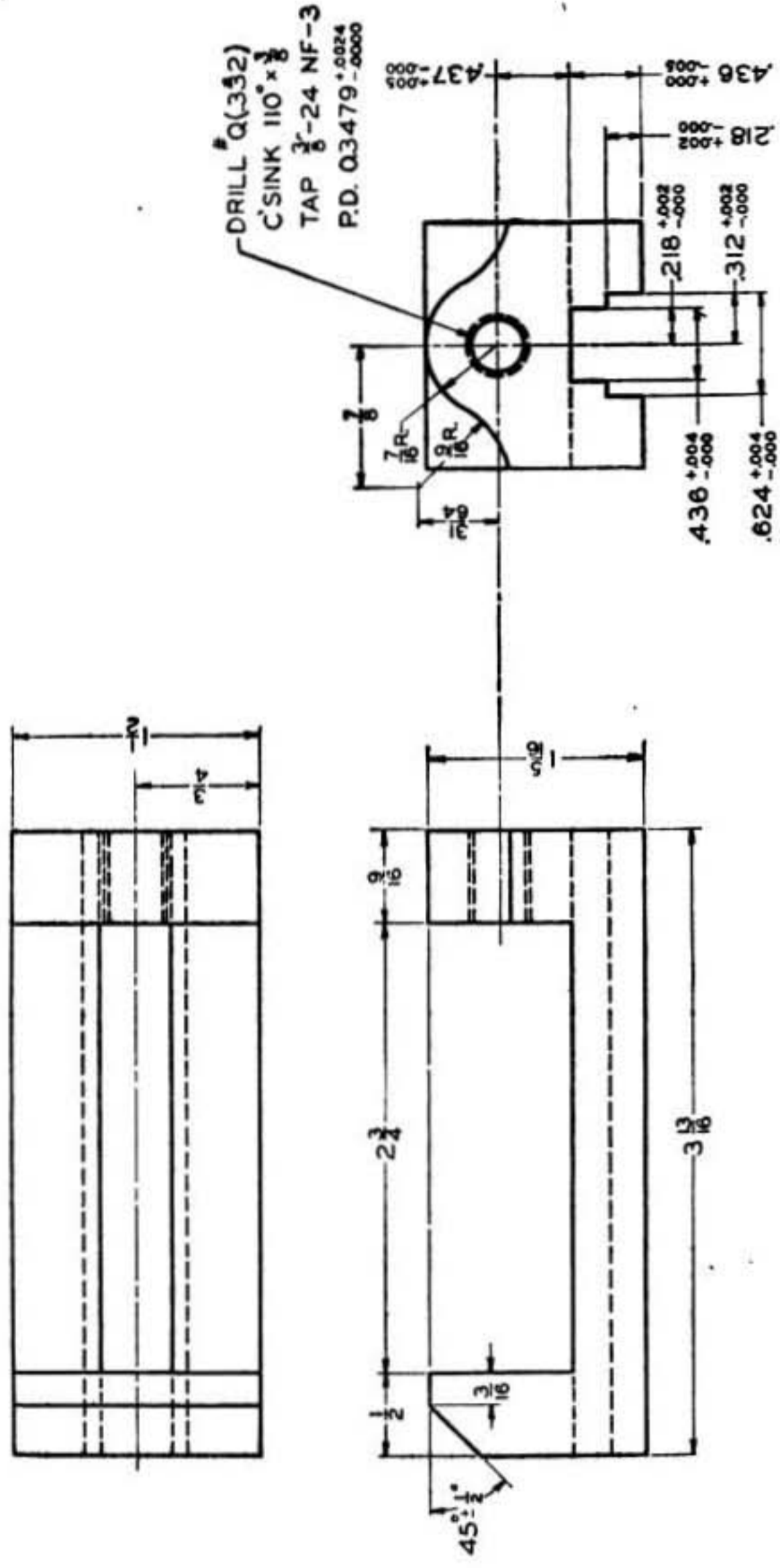

NOTE.—Limits on dimensions ±.0075 unless otherwise specified. Material—S. A. E. 1025 steel; F. A. O.—Smooth machine.

FIGURE 97.—Detail of base.

sive. The detail drawings of the screw, handle, and collar are details of the screw assembly (fig. 96), which in itself is part of the main assembly (fig. 95).

c. A bill of material may be included on the drawing, containing such notations as name and number of part, quantity required, ma-

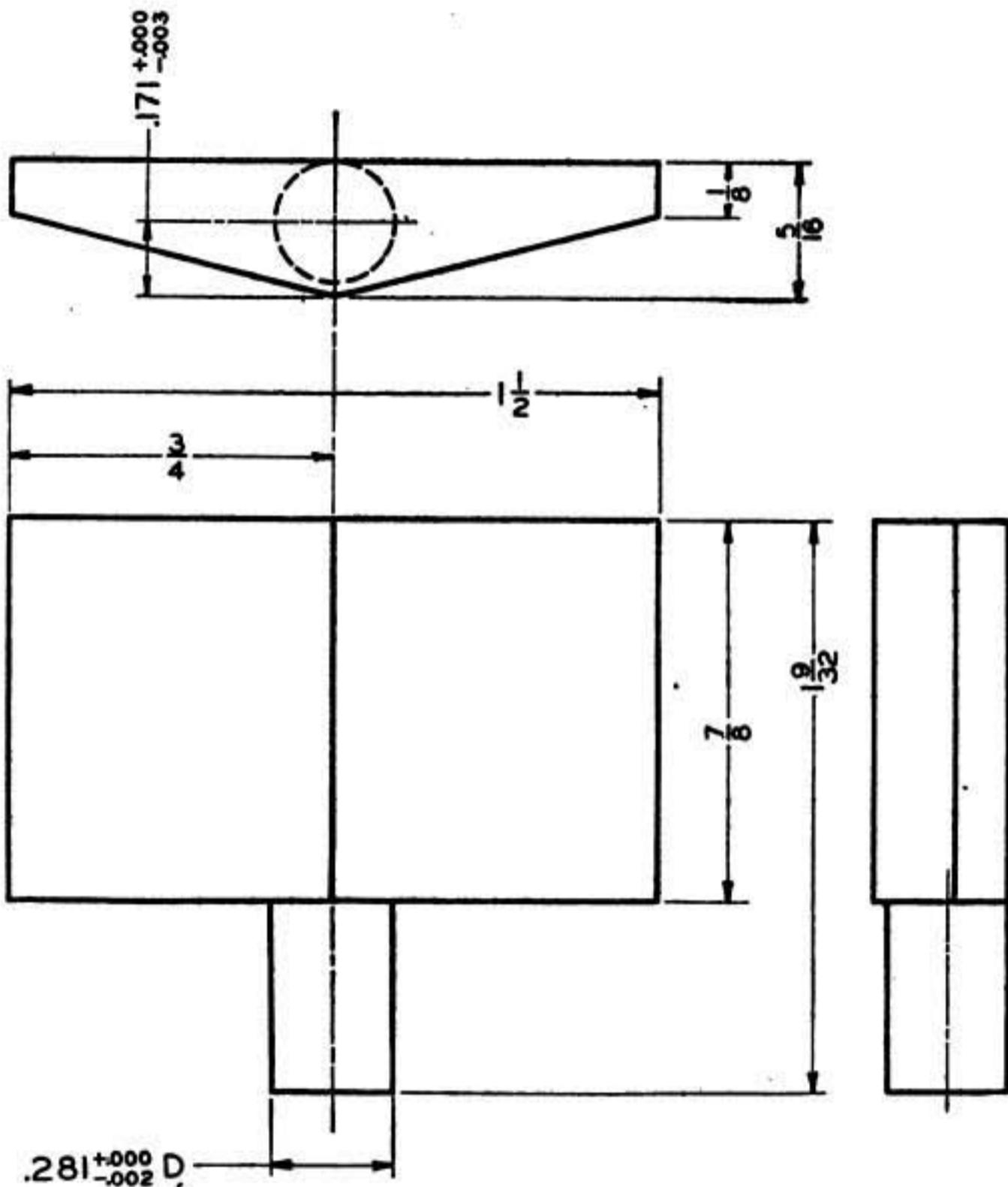

NOTE.—Limits on dimensions $\pm .0075$ unless otherwise specified. Material—S. A. E. 1025 steel; F. A. O.—Smooth machine.

FIGURE 98.—Detail of swivel jaw.

terial, and any other pertinent information. This may be issued in the form of a part list (fig. 105) on a separate sheet and issued with the drawings. This list would also include standard parts not shown on the drawing. Parts and subassemblies are listed in the reverse order of assembly, and are indented in the list to indicate their relation to the assembly or subassembly.

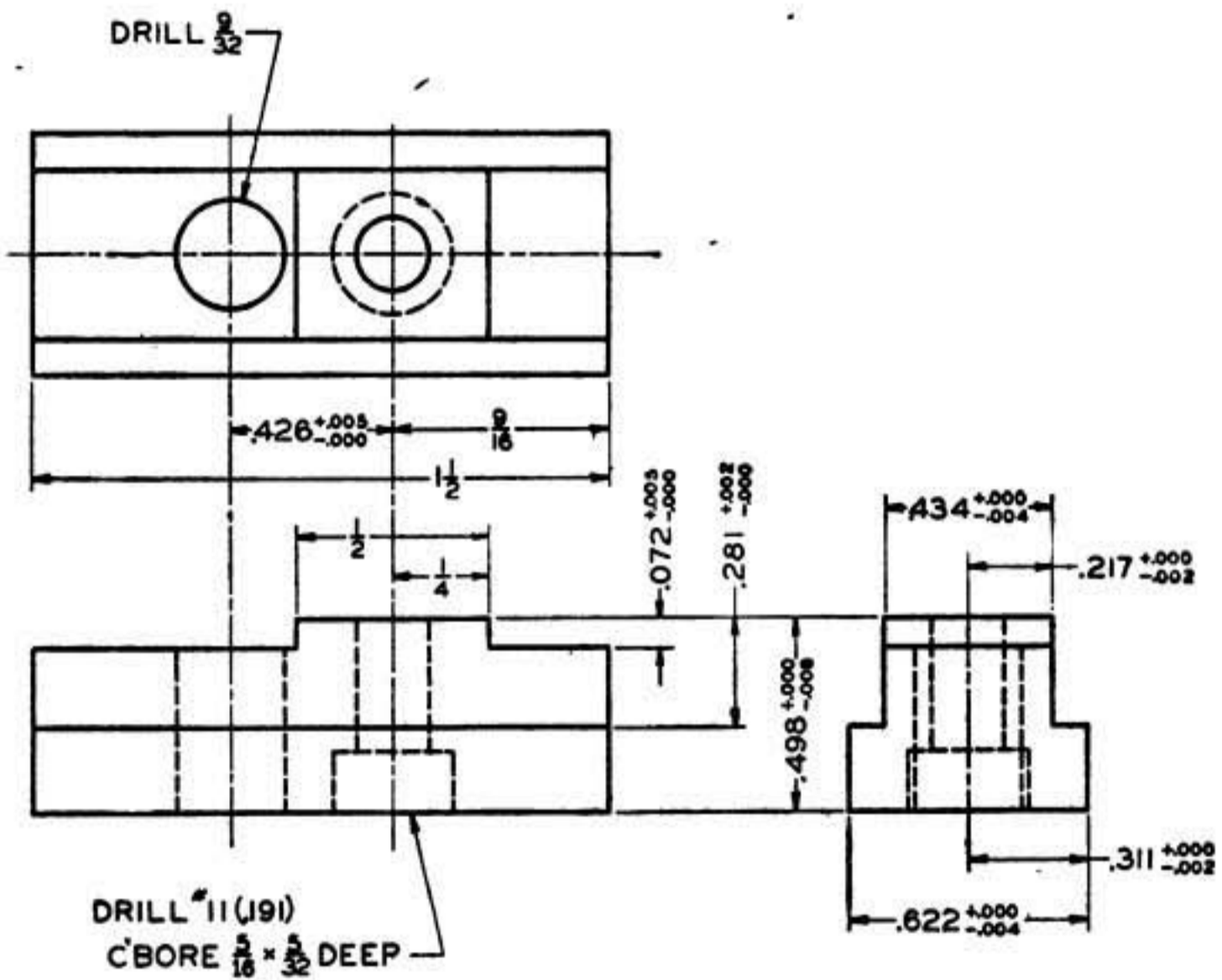

NOTE.—Limits on dimensions $\pm .0075$ unless otherwise specified. Material—S. A. E. 1025 steel; F. A. O.—Smooth machine.

FIGURE 99.—Detail of guide.

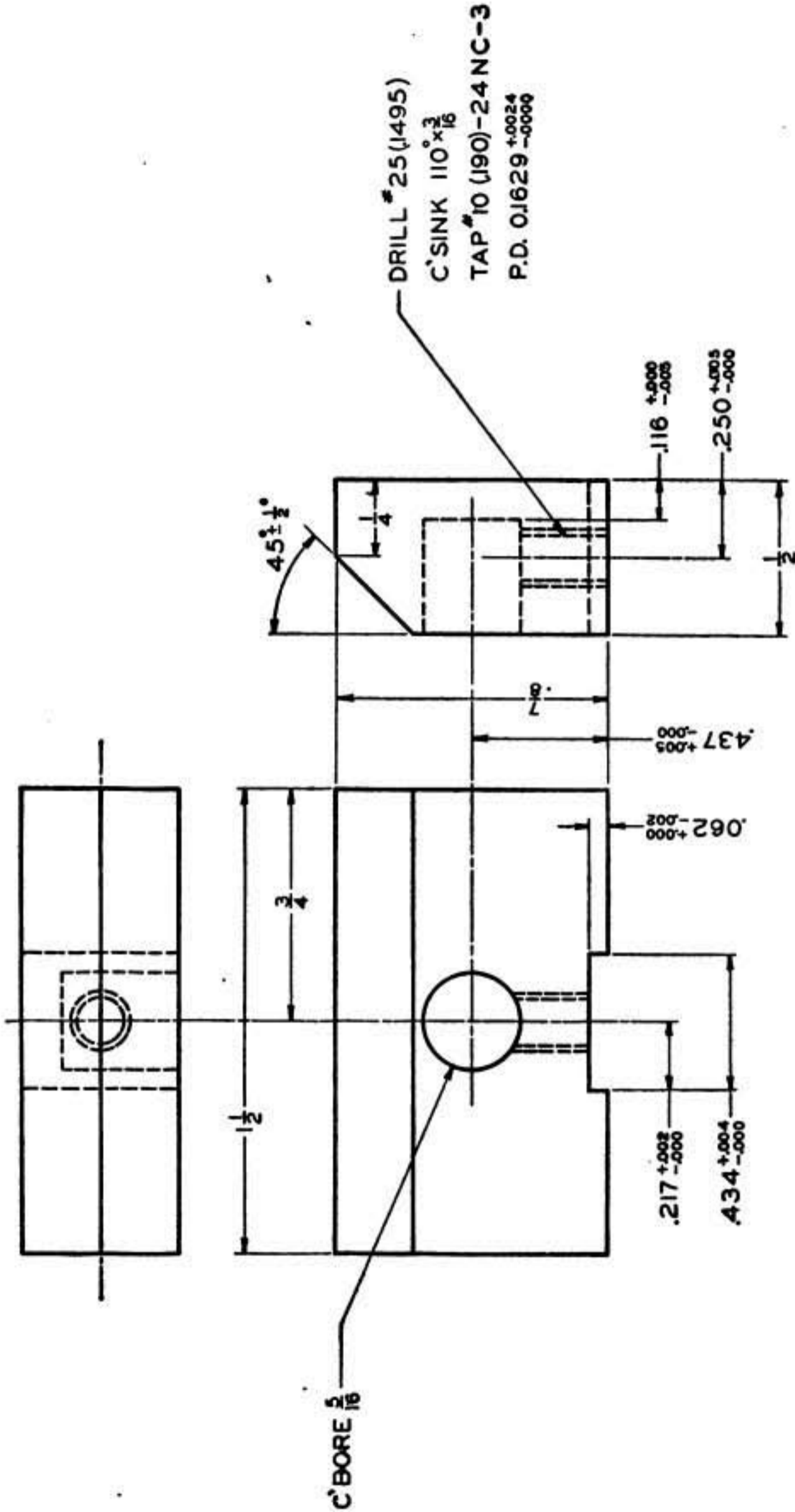

NOTE.—Limits on dimensions $\pm .0075$ unless otherwise specified. Material—S. A. E. 1025 steel; F. A. O.—Smooth machine.

FIGURE 100.—Detail of jaw.

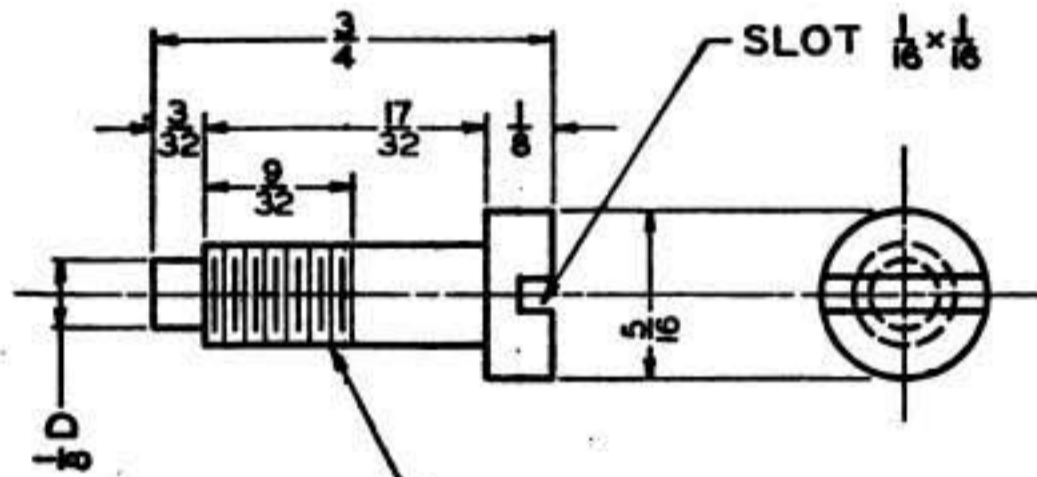

BREAK SHARP CORNERS

DIA. FOR TH'D. $0.190^{+0.0000}_{-0.0068}$
 #10-24 NC-3
 P.D. $0.1629^{+0.0000}_{-0.0024}$

NOTE.—Limits on dimensions $\pm .0075$ unless otherwise specified. Material—S. A. E. 1025 steel; F. A. O.—Smooth machine.

FIGURE 101.—Detail of retaining screw.

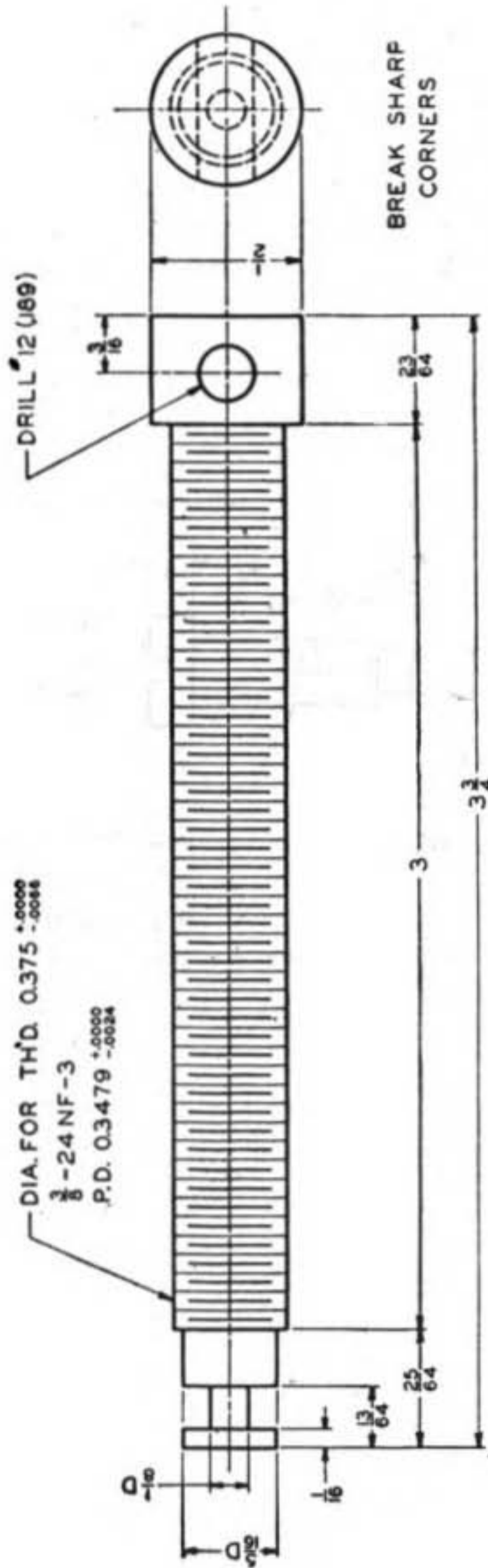

NOTE.—Limits on dimensions $\pm .0075$ unless otherwise specified. Material—S. A. E. 1025 steel; F. A. O.—Smooth machine. FIGURE 102.—Detail of screw.

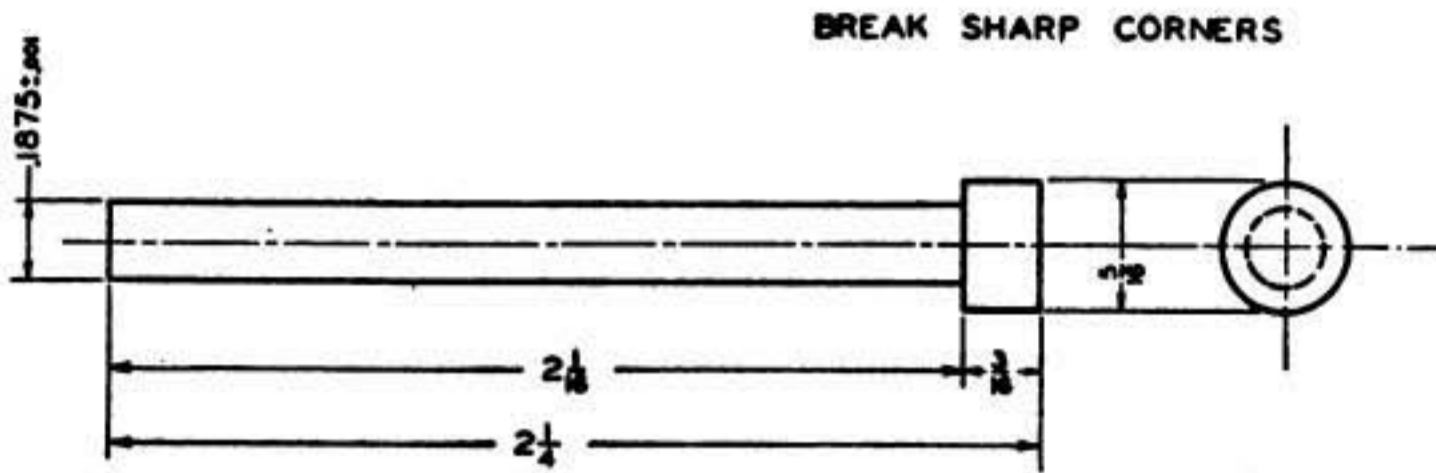

NOTE.—Limits on dimensions $\pm .0075$ unless otherwise specified. Material—S. A. E. 1025 steel; F. A. O.—Smooth machine.

FIGURE 103.—Detail of handle.

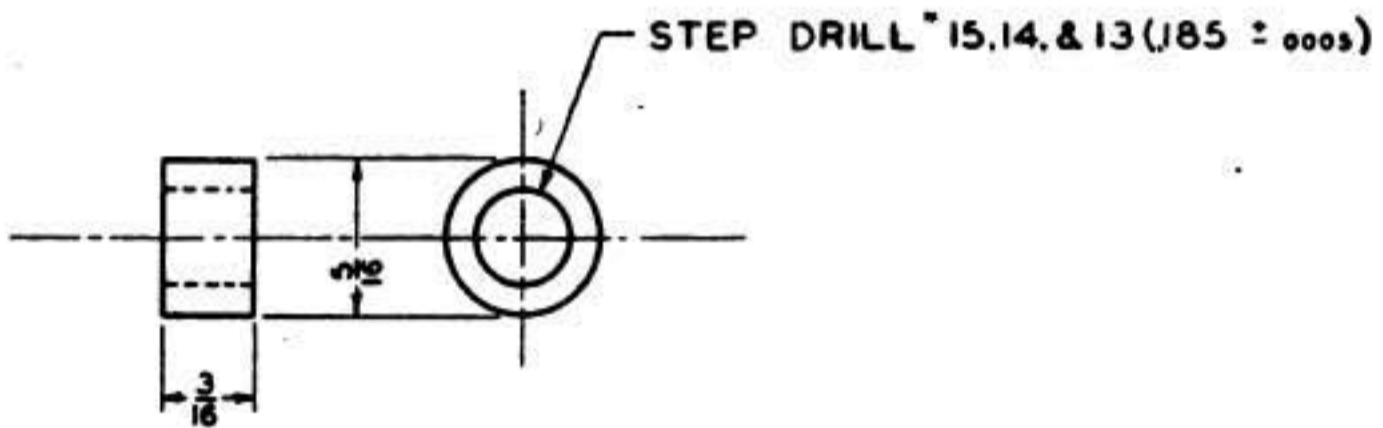

NOTE.—Limits on dimensions $\pm .0075$ unless otherwise specified. Material—S. A. E. 1025 steel; F. A. O.—Smooth machine.

FIGURE 104.—Detail of collar.

PART LIST						
ACTS DEPARTMENT OF MECHANICS CHANUTE FIELD					1 PAGES, PAGE 1	
MAJOR ITEM VISE						
ASSEMBLY UNIT						
PART NUMBER	PART NAME				NO. REQ'D.	
	1	2	3	4		
M42-27	VISE	ASSEMBLY			1	
M42-27-1		BASE			1	
M42-27-2		JAW	SWIVEL		1	
M42-27-3		GUIDE			1	
M42-27-4		JAW			1	
M42-27-5		SCREW	RETAINING		1	
M42-28		SCREW	ASSEMBLY		1	
M42-28-1			SCREW		1	
M42-28-2			HANDLE		1	
M42-28-3			COLLAR		1	

FIGURE 105.—Part list.

INDEX

	Paragraph	Page
Angle:		
Bisecting -----	22	24
Trisecting -----	23	24
Arc:		
Bisecting -----	21	24
Drawing -----	32, 33	27
Arc tangent -----	32	27
Assembly and detail drawings -----	58	79
Bisecting -----	20-22	24
Board, drawing -----	2	4
Bow instruments -----	15	15
Cabinet drawing -----	42	41
Circle -----	27	25
Cloth -----	3	4
Compass -----	3	4
Curve, irregular -----	8	8
Detail drawings -----	53	79
Development by triangulation -----	52	76
Dimensions -----	46	55
Dividers -----	14	14
Drawing board -----	2	4
Ellipse -----	34	28
Equipment and materials -----	2-16	4
Erasers -----	5	6
Geometric constructions -----	19-34	23
Hexagon -----	30	26
Instruments, bow -----	15	15
Irregular curve -----	8	8
Isometric drawing -----	40	38
Lettering -----	17	17
Lines:		
Bisecting -----	20	24
Dividing, into equal parts -----	26	25
Erecting perpendicular -----	24, 25	25
Instructions and uses -----	18	20
Parallel, development -----	50	60
Radial, development -----	51	73

INDEX

	Paragraph	Page
Notes.....	47	63
Oblique drawing.....	41	41
Octagon.....	31	27
Orthographic projection.....	35-37	28
Paper and cloth.....	3	4
Pencils.....	4	5
Pens:		
Lettering.....	12	12
Ruling.....	11	11
Pentagon.....	29	26
Perpendicular, erecting.....	24	25
Perspective drawing.....	39	37
Pictorial drawing.....	38-42	36
Protractor.....	10	11
Representative working drawings.....	53	79
Ruling pen.....	11	11
Scale of drawings.....	45	55
Scale, triangular.....	9	8
Sectional views.....	43	43
Sheet metal drafting.....	49-52	68
Sketching, technical.....	48	65
Square, constructing.....	28	26
Tangent, arc.....	32	27
Technical sketching.....	48	65
Triangles.....	7	7
Triangulation, development by.....	52	76
Triangular scale.....	9	8
Treaded parts.....	44	49
Trisecting a right angle.....	23	24
T-square.....	6	6

[A. G. 062.11 (2-4-48).]

BY ORDER OF THE SECRETARY OF WAR:

G. C. MARSHALL,
Chief of Staff.

OFFICIAL:

J. A. ULIO,
Major General,
The Adjutant General.

DISTRIBUTION:

B and H 1 (2).
(For explanation of symbols see FM 21-6.)