

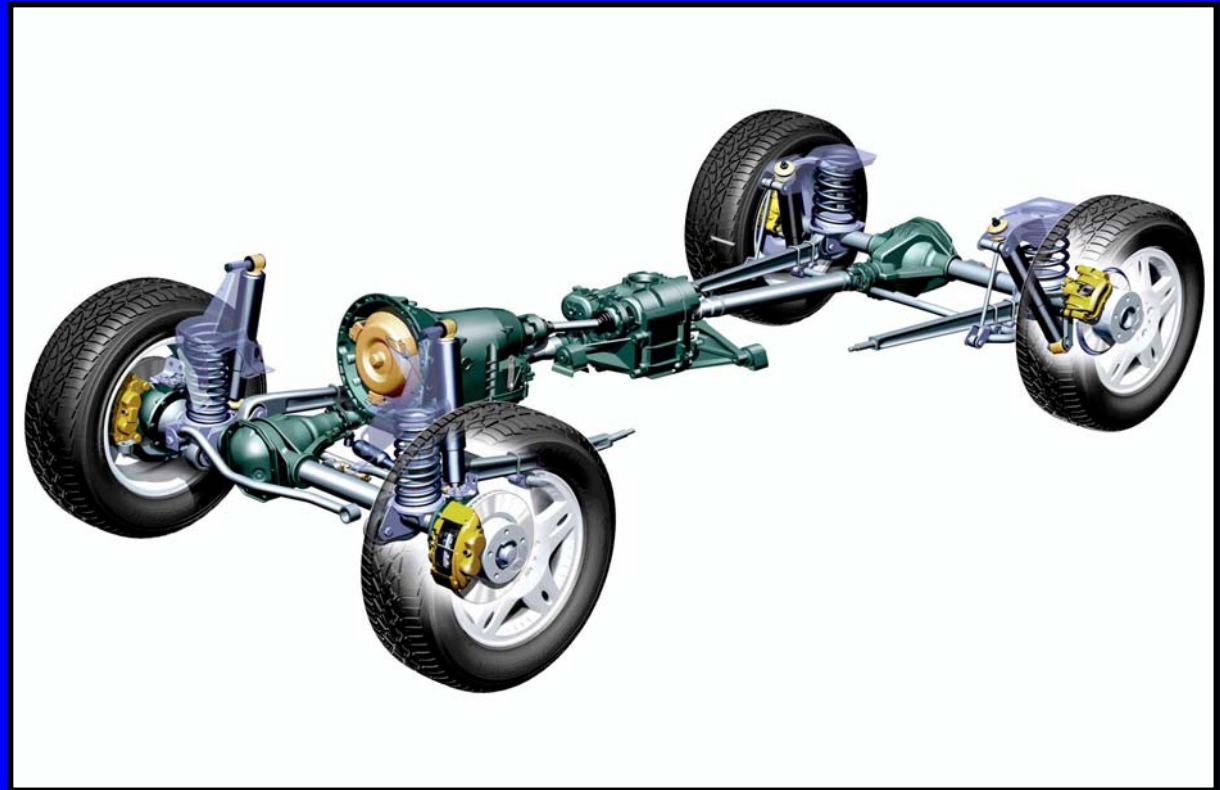

Mercedes-Benz

# G Class Axles & Propeller Shafts



These technical training materials are current as of the date noted on the materials, and may be revised or updated without notice. Always check for revised or updated information.

To help avoid personal injury to you or others, and to avoid damage to the vehicle on which you are working, you must always refer to the latest Mercedes-Benz Technical Publication and follow all pertinent instructions when testing, diagnosing or making repair. Illustrations and descriptions in this training reference are based on preliminary information and may not correspond to the final US version vehicles. Refer to the official introduction manual and WIS when available.

*Copyright Mercedes-Benz USA, LLC, 2003*

*Reproduction by any means or by any information storage and retrieval system or translation in whole or part is not permitted without written authorization from Mercedes-Benz USA, LLC or its successors.*

*Published by Mercedes-Benz USA, LLC*

*Printed in U. S.A.*

# Front Axle Maintenance

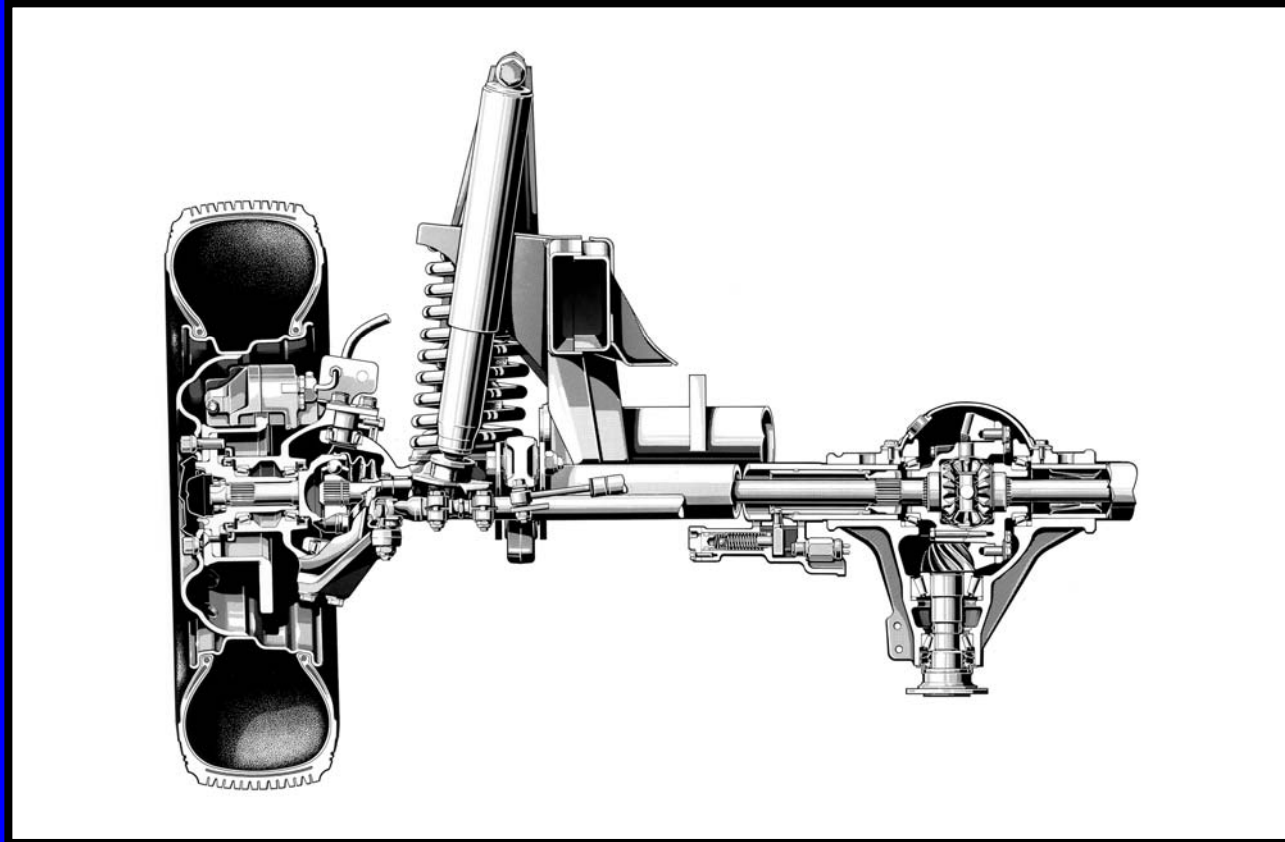

- Every 2 years check / correct grease packing of joint housing
- Every B service check oil level
- Oil change - 60,000 miles or 5 years since last change
- Oil grade - SAE 85W 90, 90 (sheet #231.1)  
1.4 liters or 1.5 quarts

# Rear Axle Maintenance

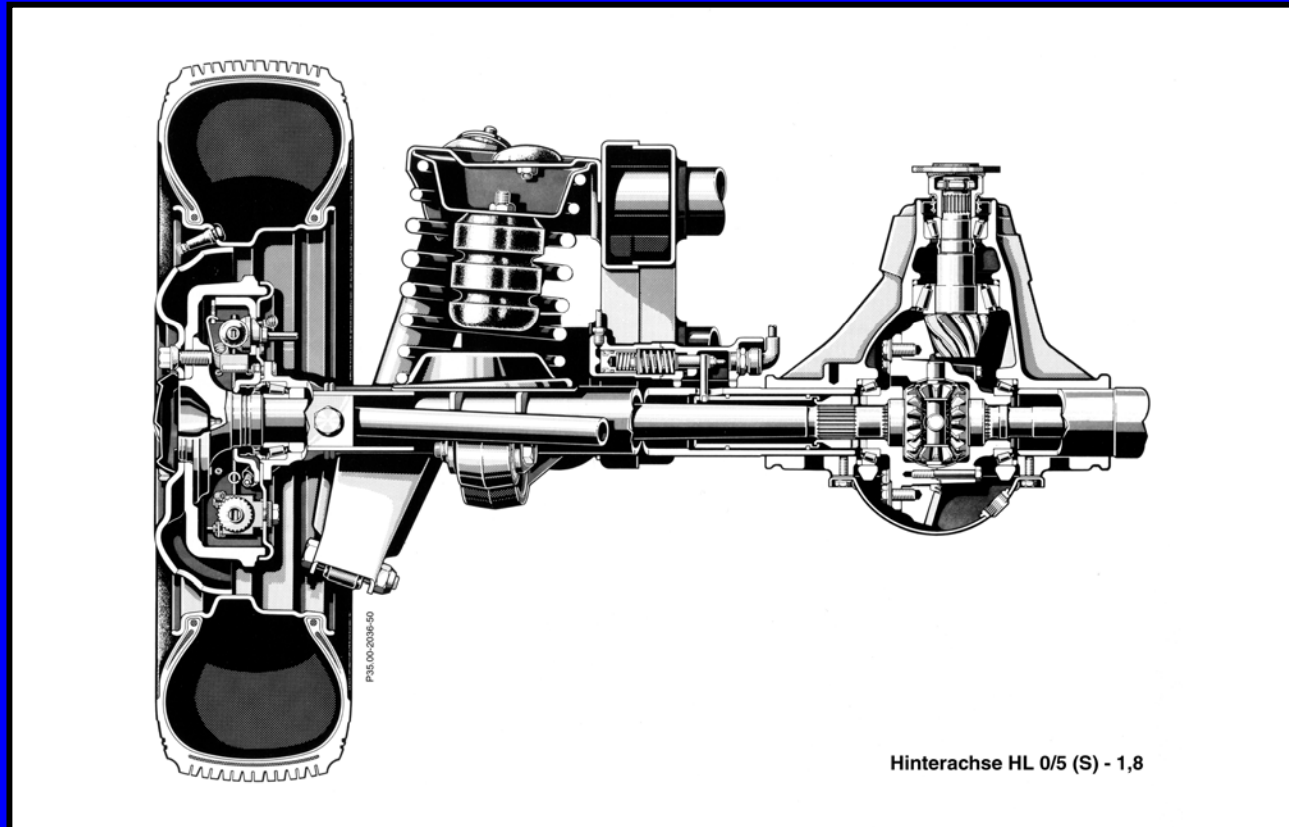

- Every B service check oil level
- Oil change - 60,000 miles or 5 years since last change
- Oil grade - SAE 85W 90, 90 (sheet #231.1)  
1.8 liters or 1.9 quarts

# Propeller Shaft Maintenance

## Universal Joints

- Every A & B service lubricate
- Requires MB long life grease (000 989 63 51)
- Lubricate U-joints until new grease exits



## Slip Joints

- Every A & B service lubricate
- Requires MB long life grease (000 989 63 51)
- Use drive-on lift
  - Do not overfill, lubricate with 3 - 4 strokes (approx. 3 cm<sup>3</sup>)



Note: U-joints not serviceable  
(replace propeller shaft)

# Propeller Shafts



Propeller shaft to rear differential

Note: "Phased-off" universal joints

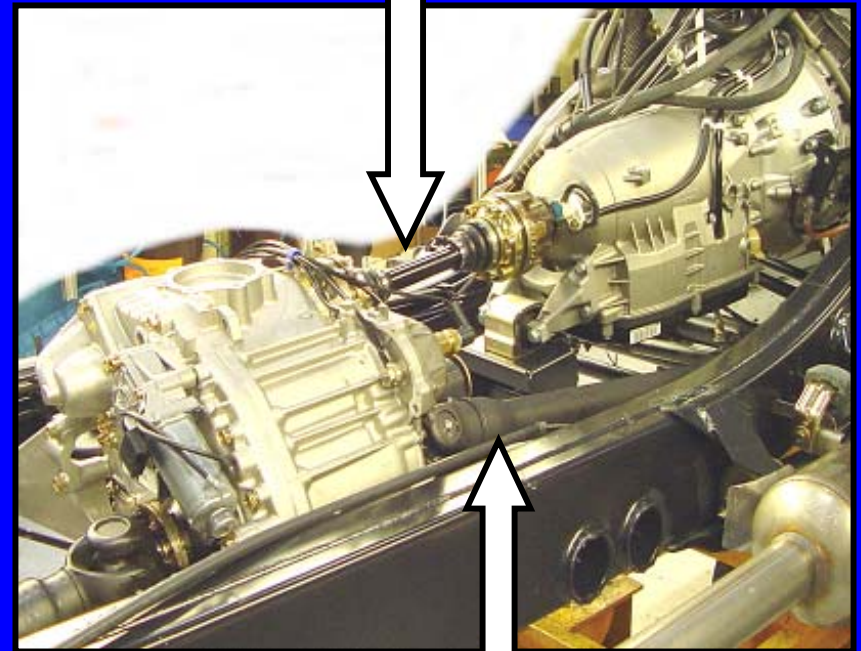

Propeller shaft to transfer case

Propeller shaft to front differential

# Propeller Shafts

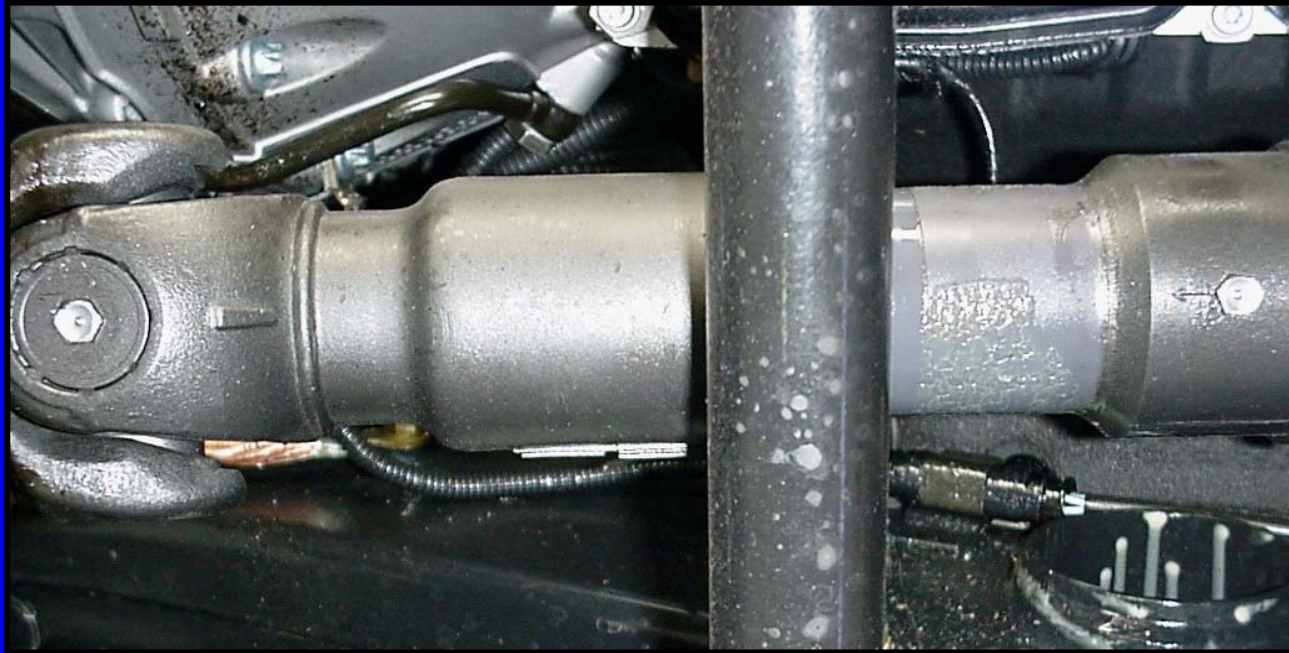

Prior to removal of any propeller shaft:

- Mark the installed position of shafts to flanges!

When installing new propeller shafts observe the following:

- Slip joints must be assembled arrow to arrow or arrow to grease nipple
- Rotate the shaft while tightening evenly to prevent binding of joints

# Propeller Shaft

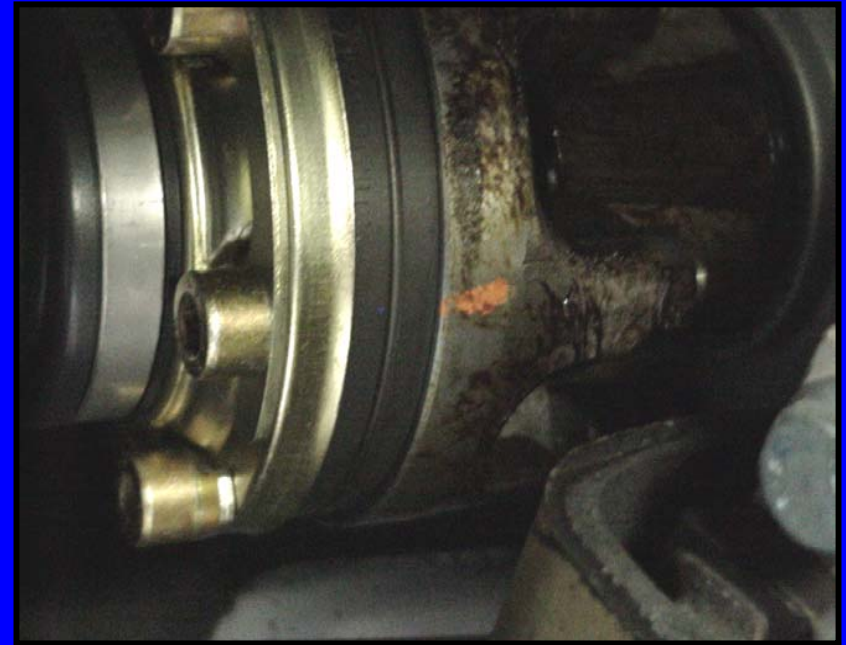

Installation of input propeller shaft:

- color marks must be installed 180° offset



# Axle Centerpiece

- 6. Drive shaft, left
- 7. Drive shaft, right
- 8. Axle housing
- 9. Drive flange
- 24. Filler plug
- 25. Crown wheel
- 26. Differential cover
- 27. Spider gears
- 28. Drive pinion
- 29. Differential housing
- 30. Differential side gears

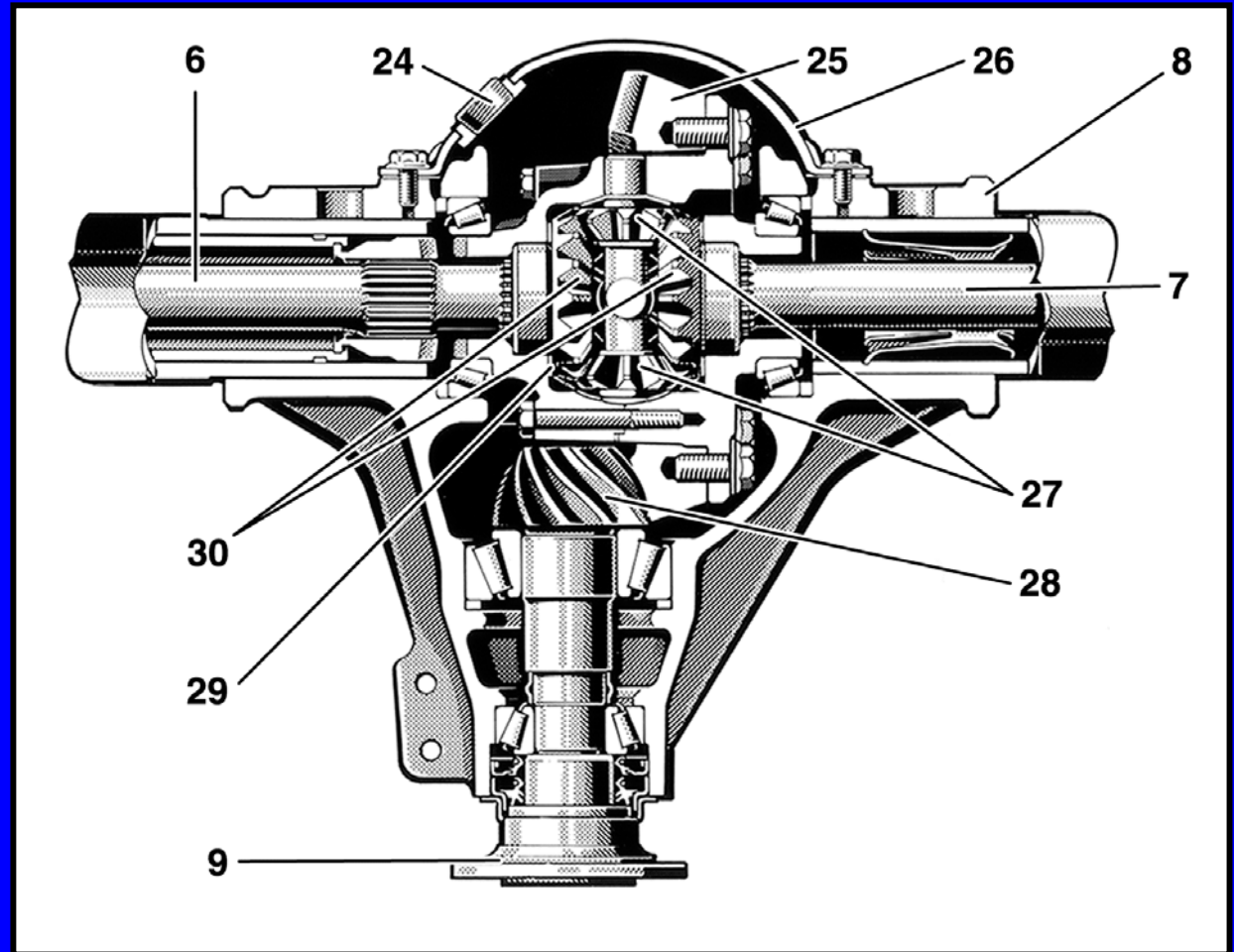

Fully serviceable - Use correct tools as described in WIS

# Pinion Seals

2. Ring
3. Oil retainer
4. Compression ring
5. O-ring
6. Inner radial seal ring
7. Outer radial seal ring

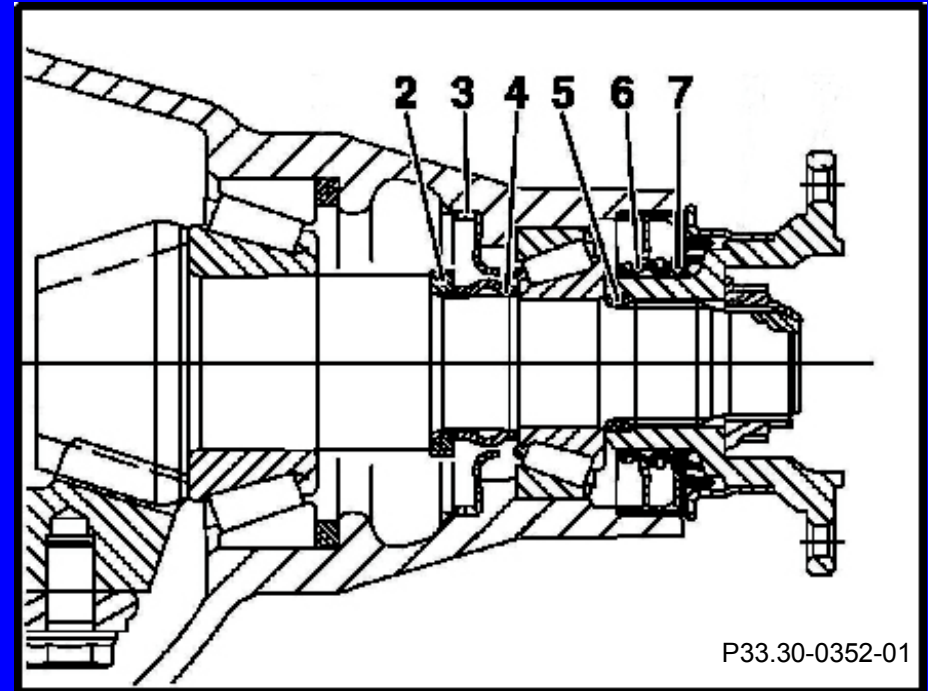

## Replacing pinion seal:

- Prior to removing drive flange measure friction torque (without wheels)
- Mark drive flange to drive pinion, unlock and remove nut
- Remove drive flange with puller (do not use hammer)
- Remove seals and replace as per WIS
- Install drive flange with new nut and tighten until friction torque is 0.5 Nm higher than previously measured
- Lock nut by bending tab

# Front Axle

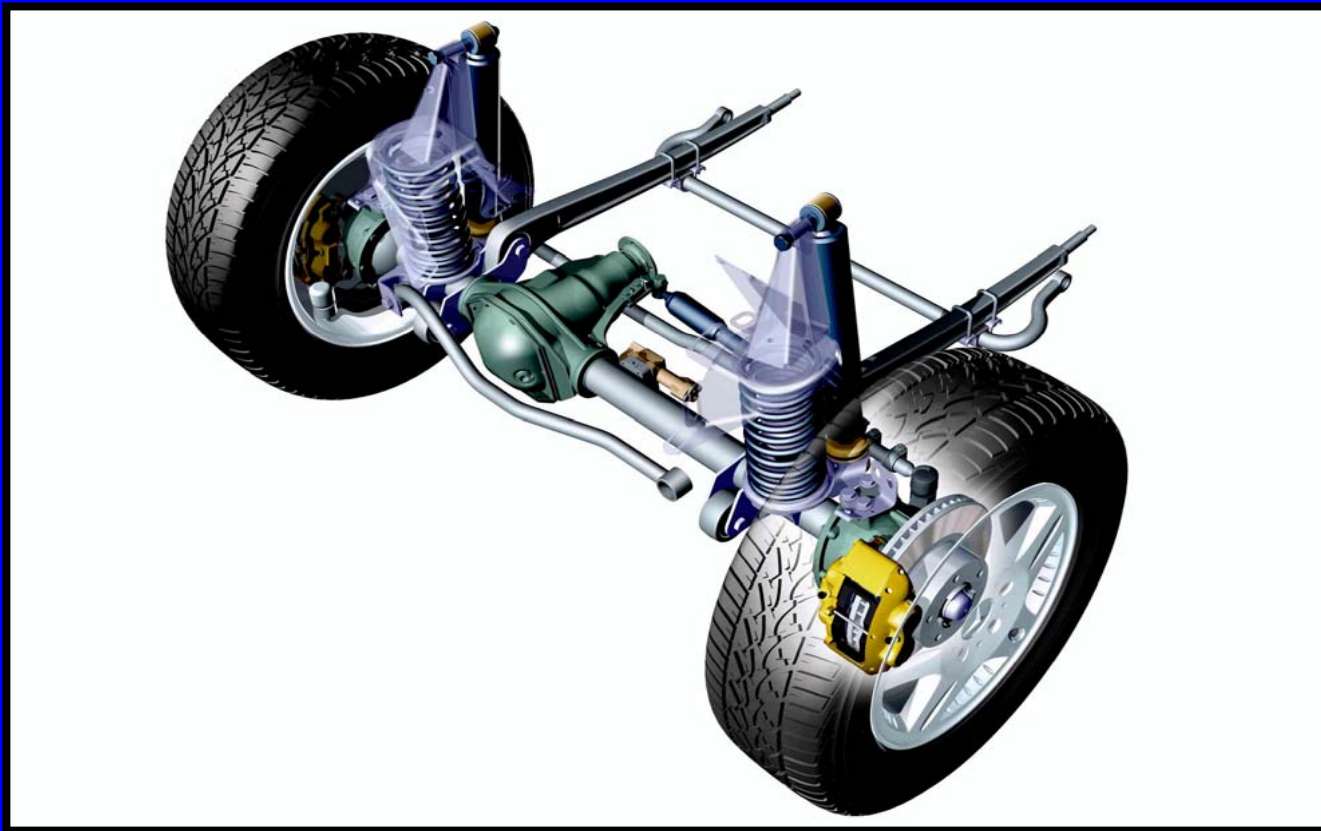

Unit # 730.390  
(type VI in WIS window)

# Joint Housing



One mounting bolt has a secondary function as a steering lock stop.

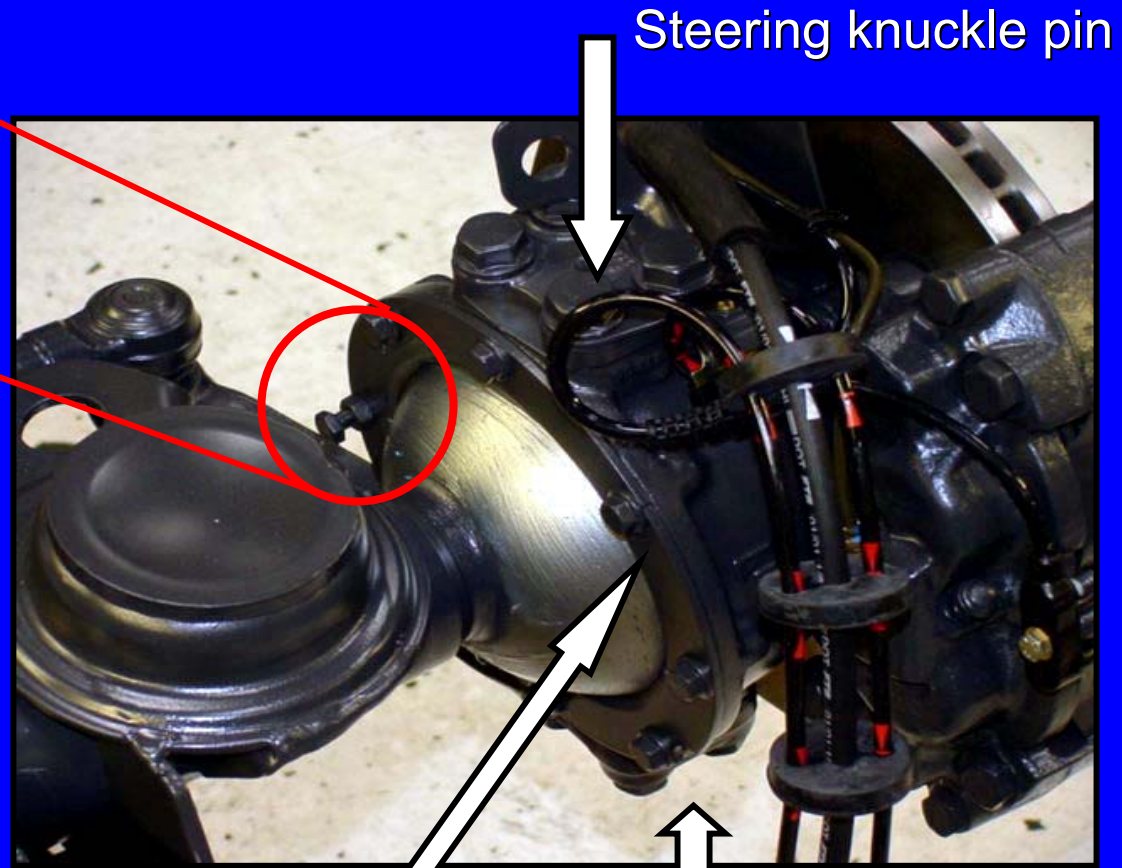

Steering knuckle pin

Seal retainer

Steering knuckle arm

# Joint Housing

- 5. Joint housing
- 6. Wheel hub
- 7. Grease cap
- 8. Inner slotted nut
- 9. Tab washer
- 10. Outer slotted nut
- 11. Drive shaft
- 12. Tapered roller bearing

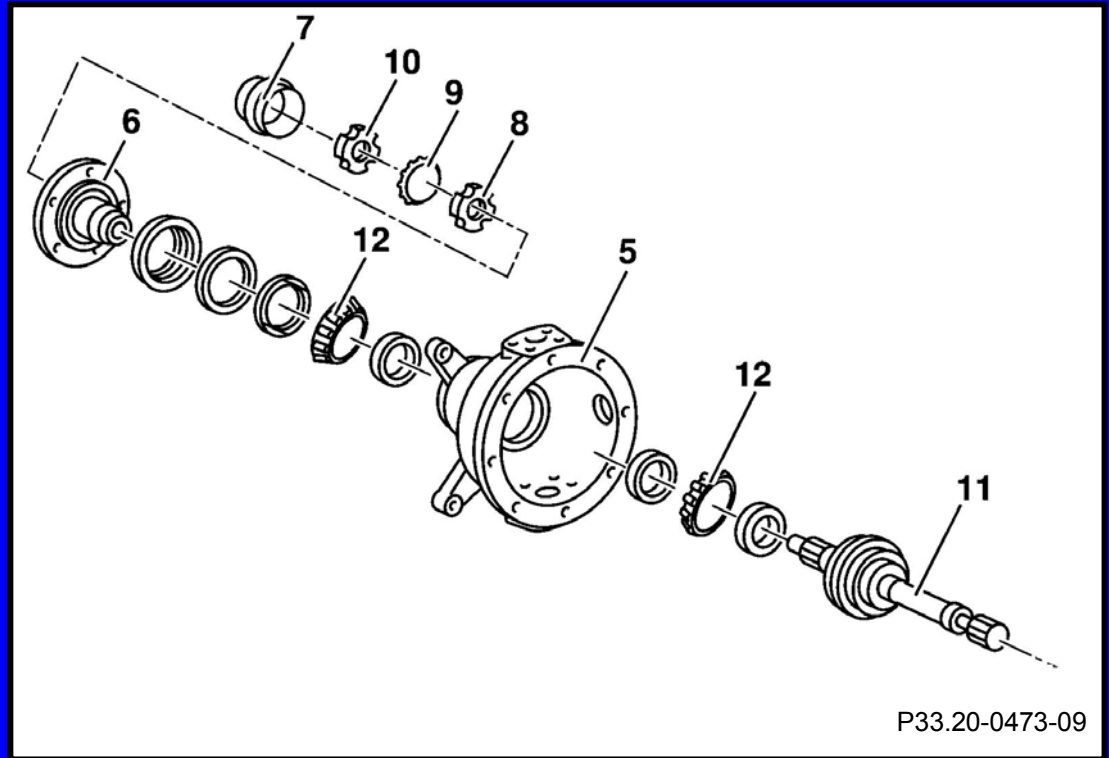

Fully serviceable - Use correct tools as described in WIS

# Joint Housing Bearings

- Tapered roller bearings
  - wheel bearings (2)
  - steering knuckle (2)
- Bushing
  - drive shaft



Tool for wheel bearing adjustment  
463 589 00 70 00

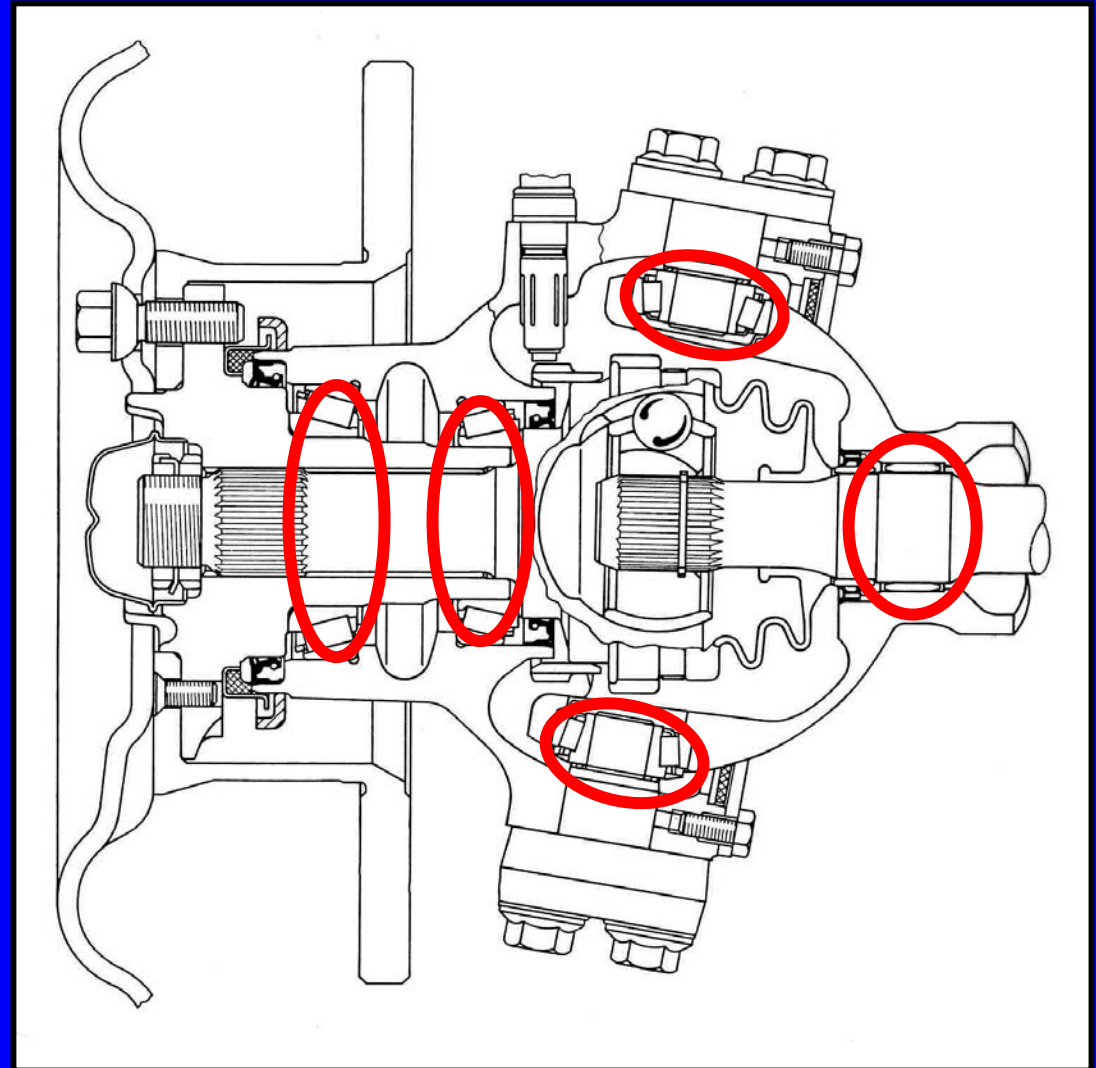

# Steering Knuckle

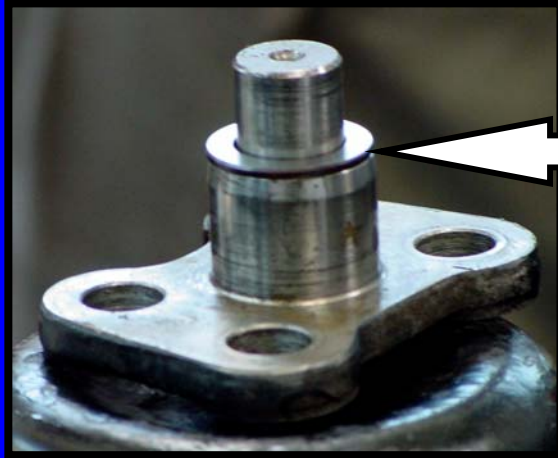

Steering  
knuckle  
pre-load  
adjusting  
shims

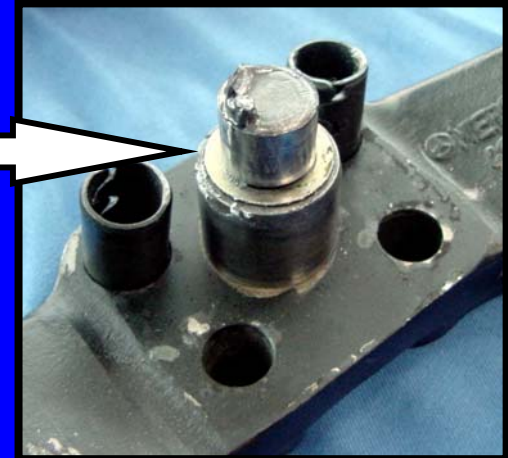

# Steering Knuckle

- With joint housing removed, tapered roller bearings are accessible
- Watch for cup-shaped washers (chrome at bottom) and shims on outer surface
- Upper and lower bearings have different inside diameters
- If parts replaced adjust bearing pre-load

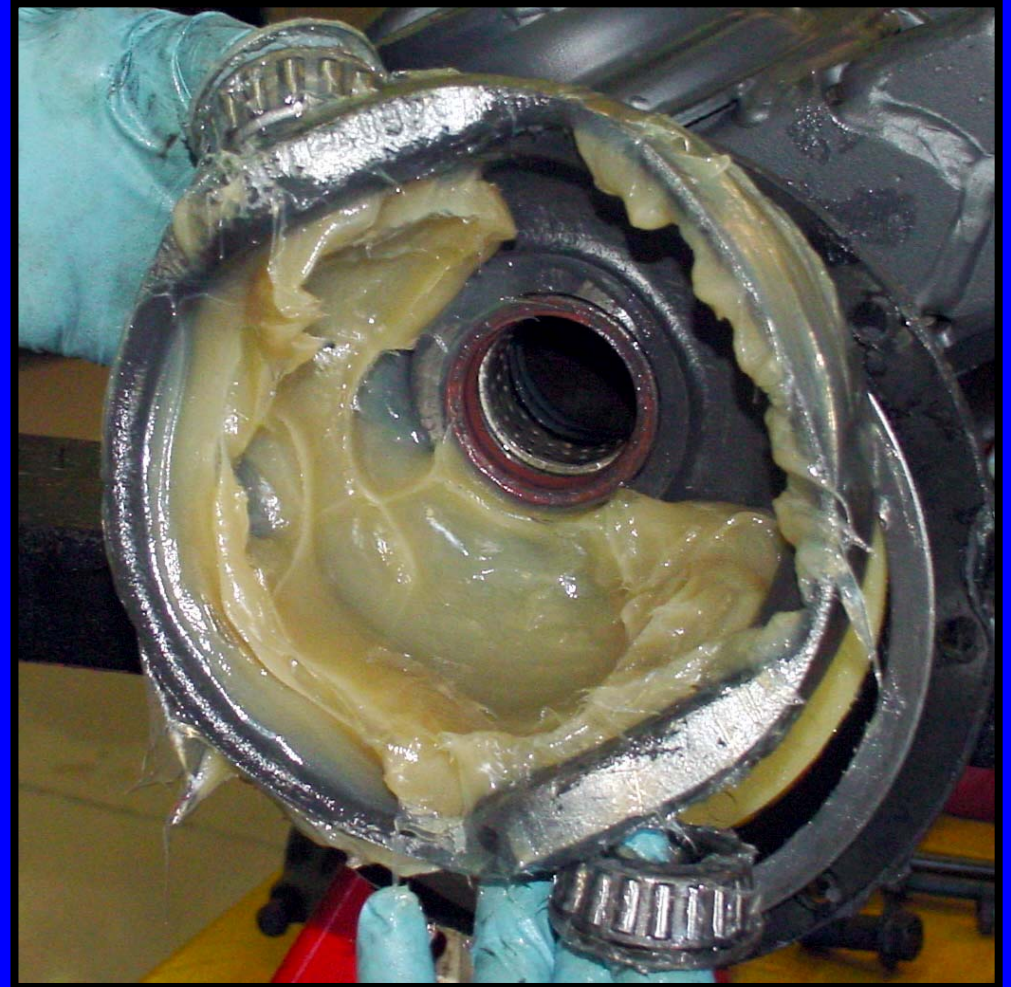



# Steering Knuckle Pre-load

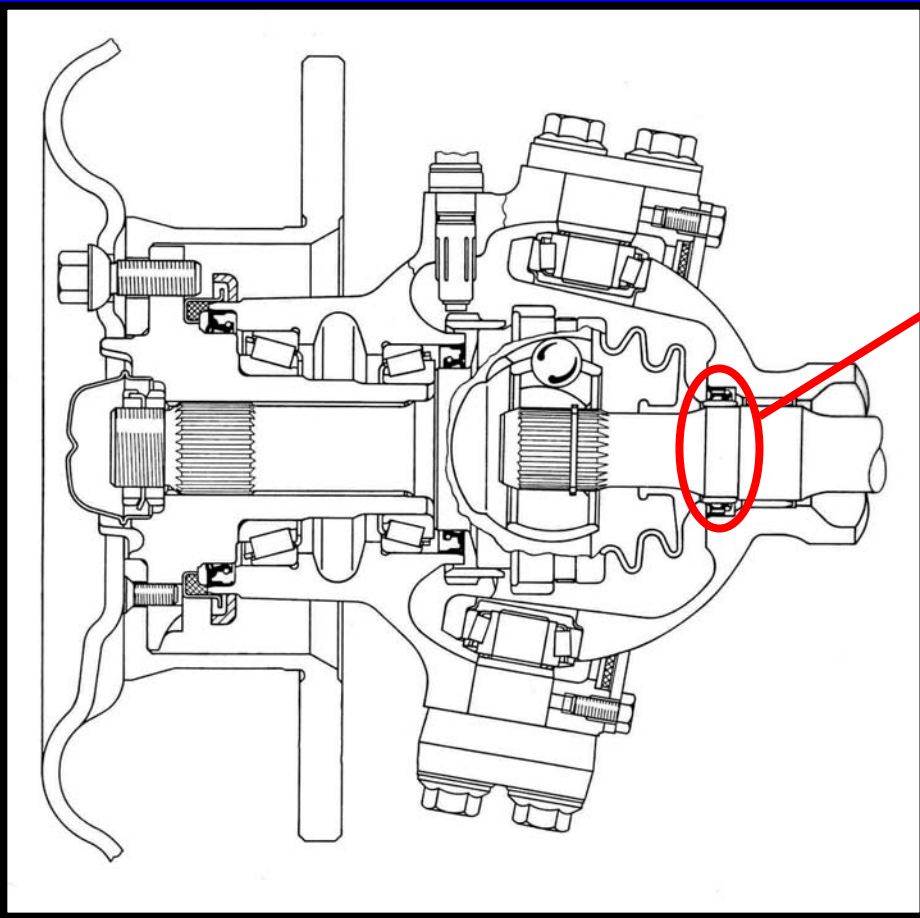

Step 1:

Install the guide ring tool that fits the axle driveshaft seal position in the joint housing without play.



460 589 01 14 00

# Steering Knuckle Pre-load

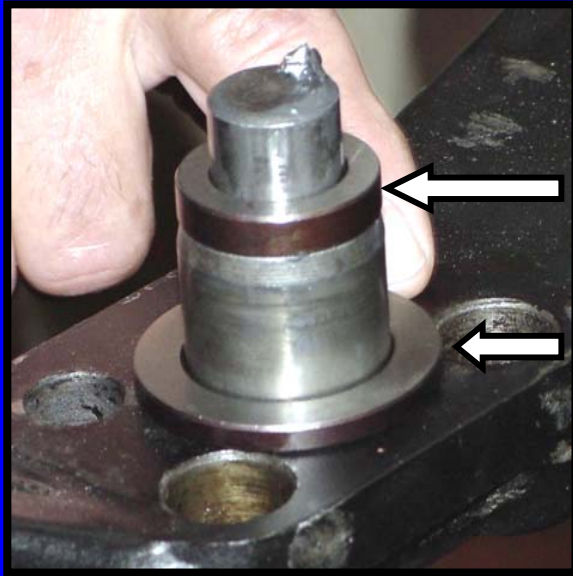

6.0mm

4.0mm

Step 2

Install 4.0mm and 6.0mm spacers on steering knuckle arm as shown.

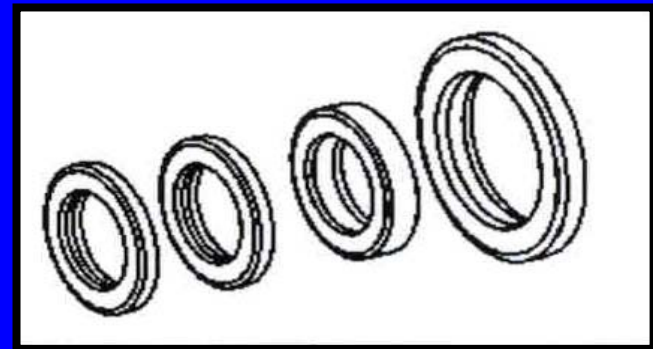

463 589 00 23 00

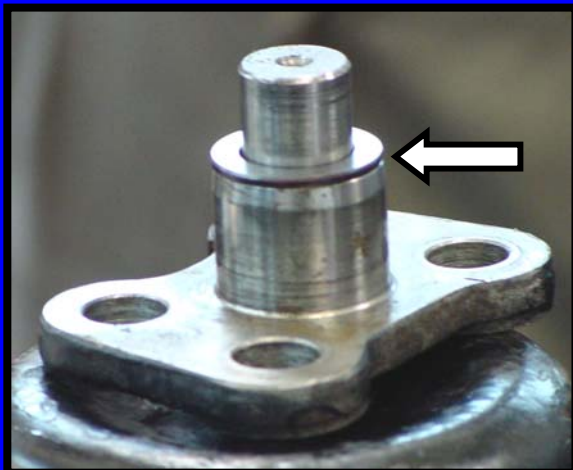

2.0mm

Install 2.0mm spacer on steering knuckle pin.

# Steering Knuckle Pre-load

Step 3



Install steering knuckle pin and arm.  
Tighten clamp (460 589 04 31 00) until  
there is no play in steering knuckle mount.

Step 4

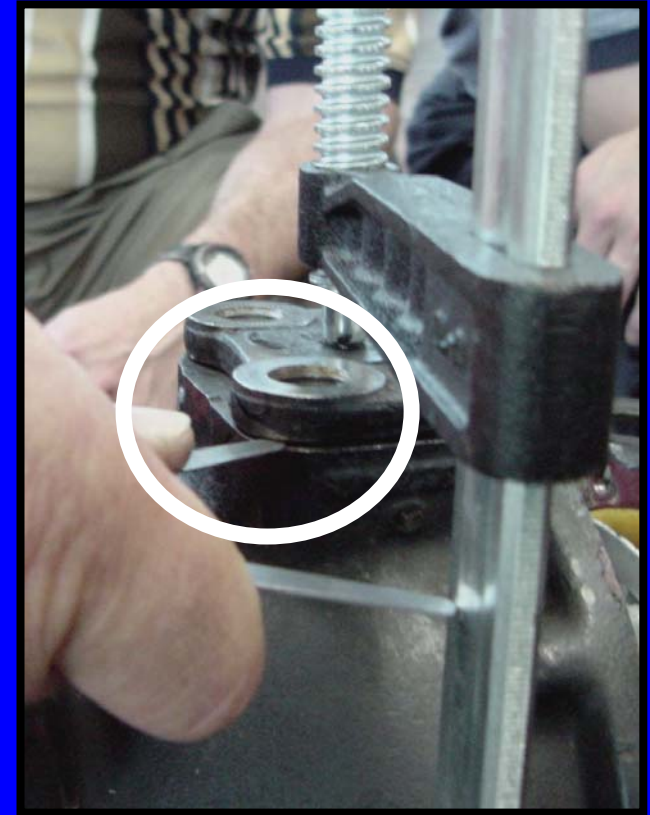

Measure gap (feeler gauge) at top for  
steering knuckle pin (**Gap A**) and at  
bottom for steering knuckle arm (**Gap B**).

# Steering Knuckle Pre-load

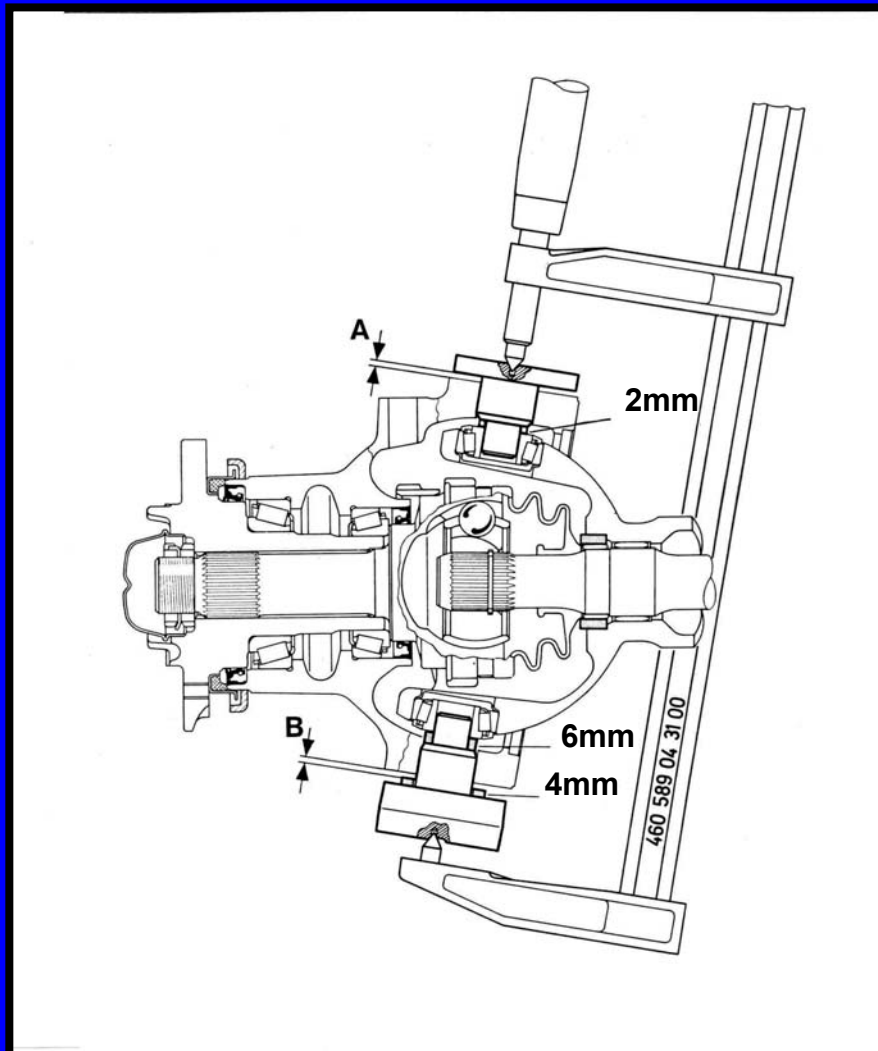

Determine shim required:

2.15 mm  
 - Gap A

= shim needed on steering knuckle pin

2.15 mm  
 - Gap B

= shim needed on steering knuckle arm

# Joint Housing Seals

Wheel bearing

Seal retainer

Driveshaft

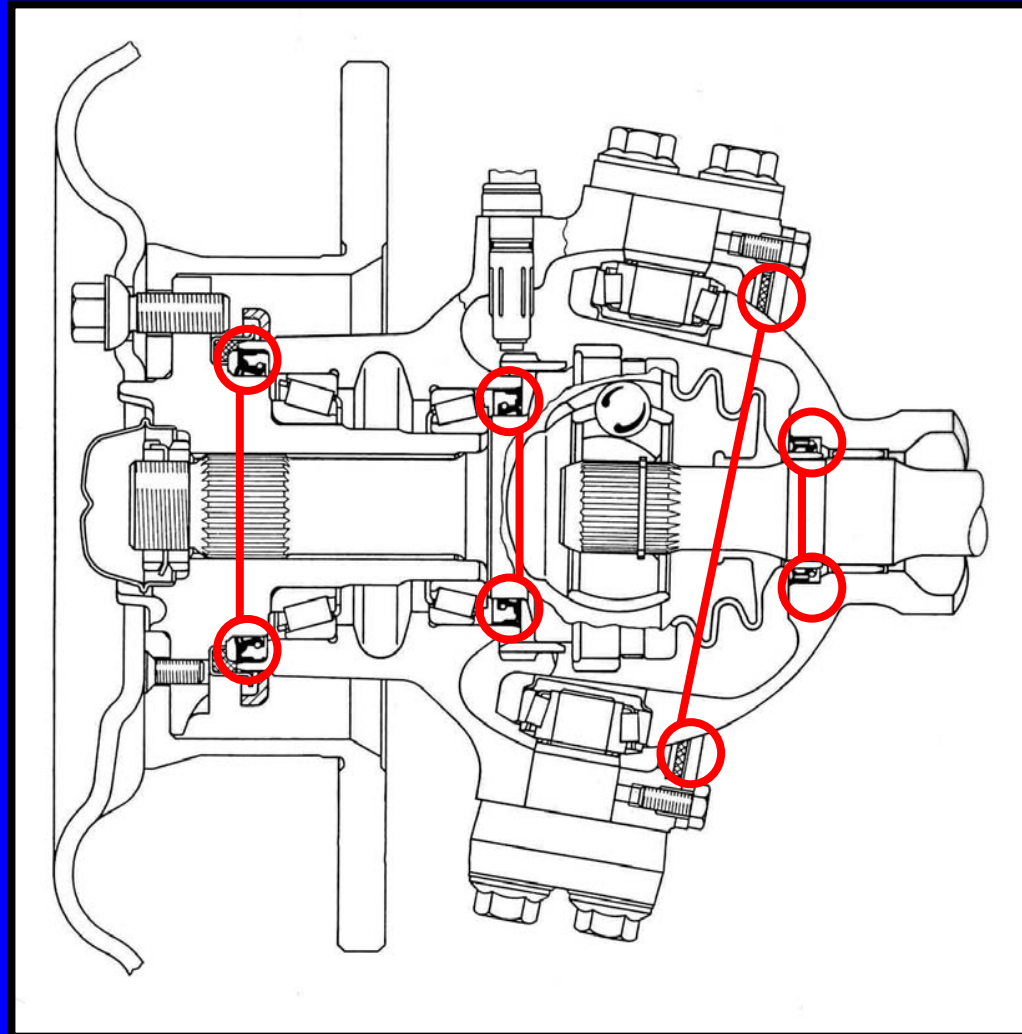

# Joint Housing Seals

Joint housing is sealed to “ball” using:

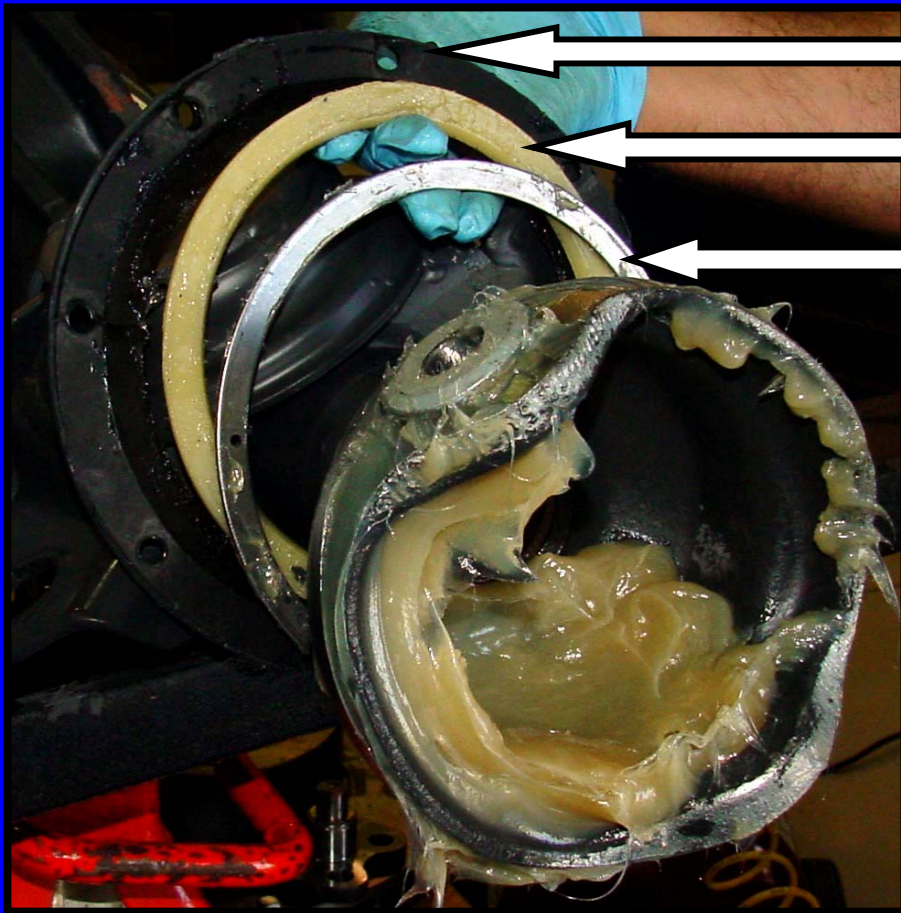

Paper gasket

Sealing ring

Steel ring

Driveshaft seal

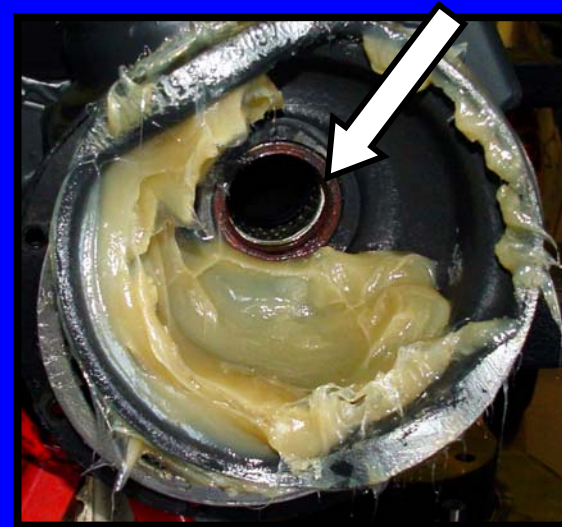

# Driveshaft

1. Hose clip
2. Rubber boot
3. Spring washer
4. Joint piece
5. Bushing

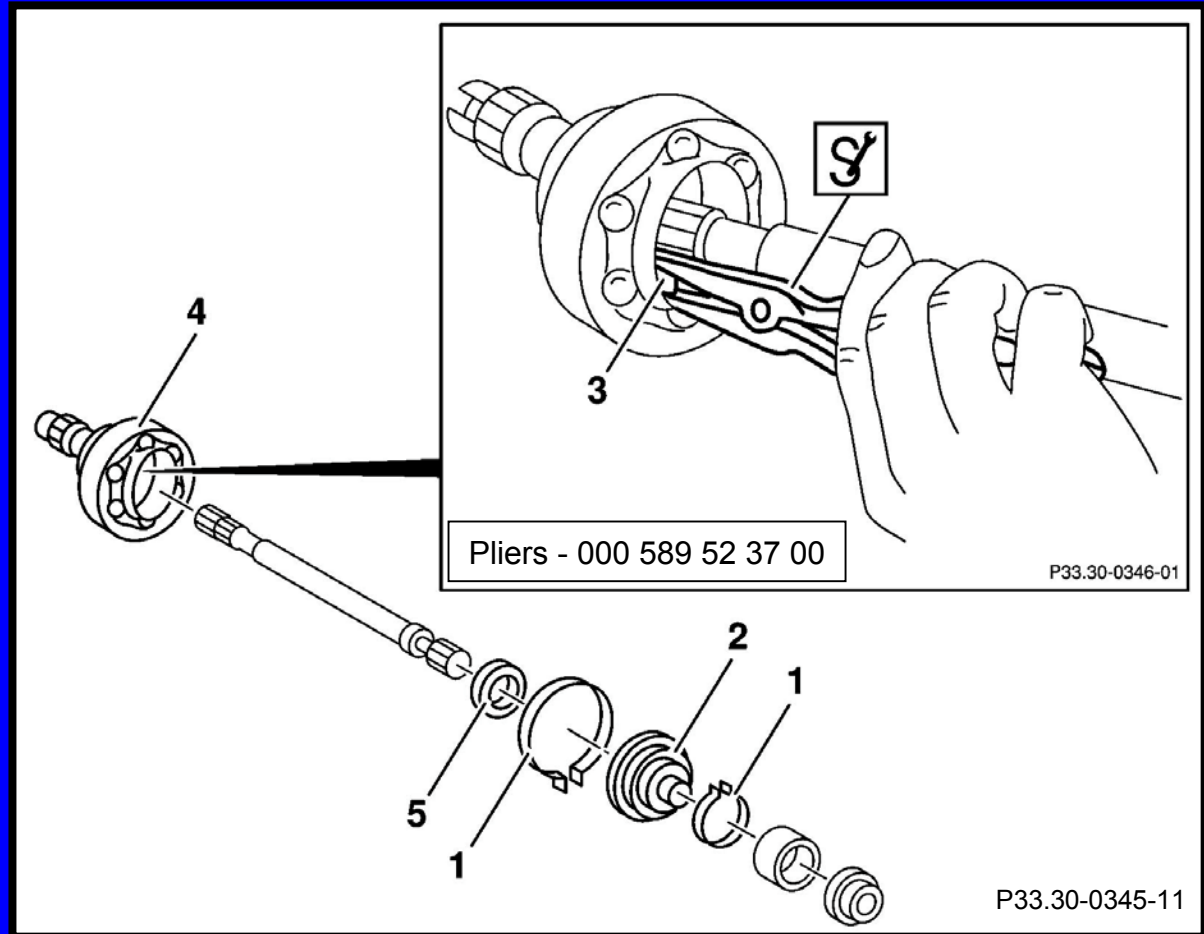

Fully serviceable - Use correct tools as described in WIS

# Rear Axle

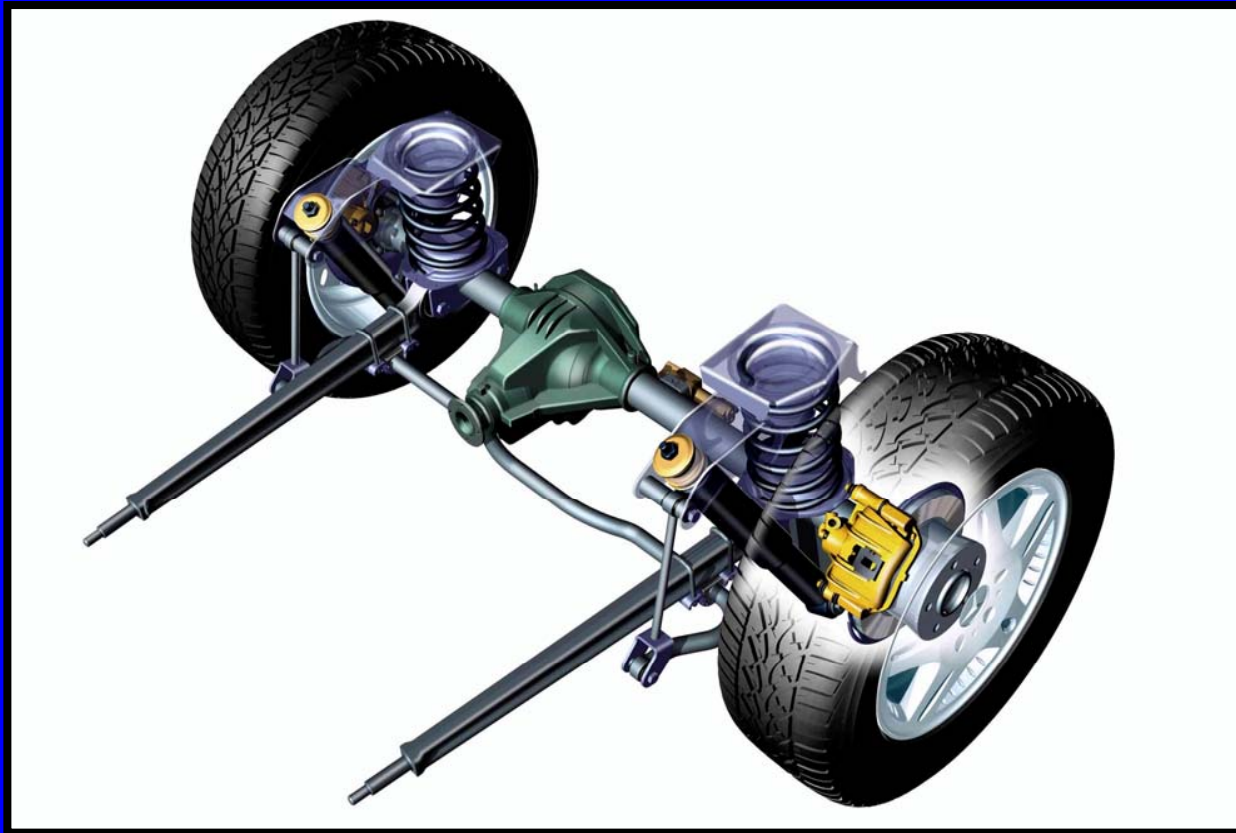

Unit # 741.142  
(type HI in WIS window)



# Driveshaft

- 2 - Bearing cap
- 3 - Radial shaft seal
- 4 - Gasket
- 6 - Bearing
- 7 - Seal
- 8 - Locking plate
- 9.1 - Grooved nut with RH thread
- 9.2 - Grooved nut with LH thread

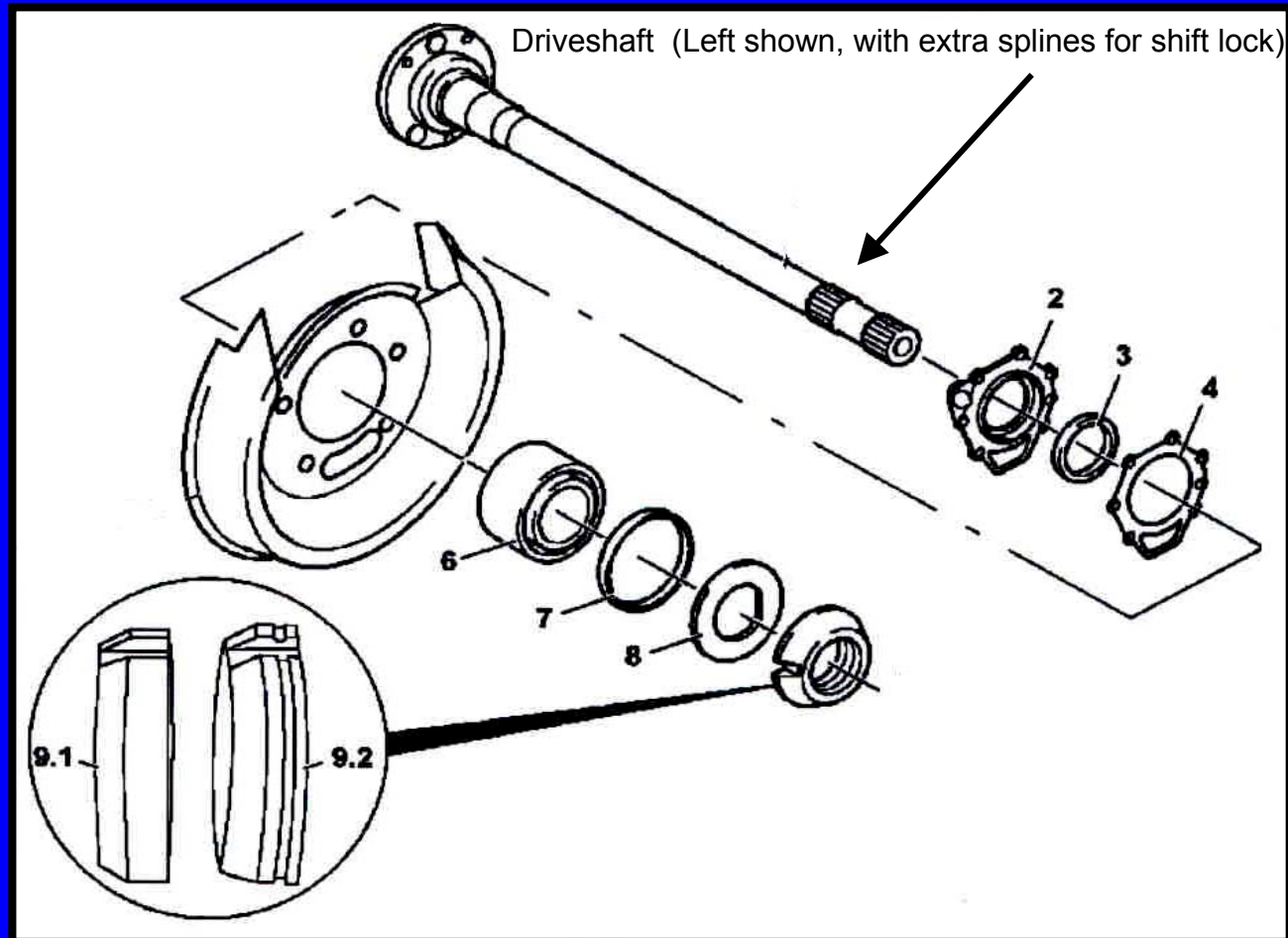

Fully serviceable - Use correct tools as described in WIS

# Driveshaft Bearing

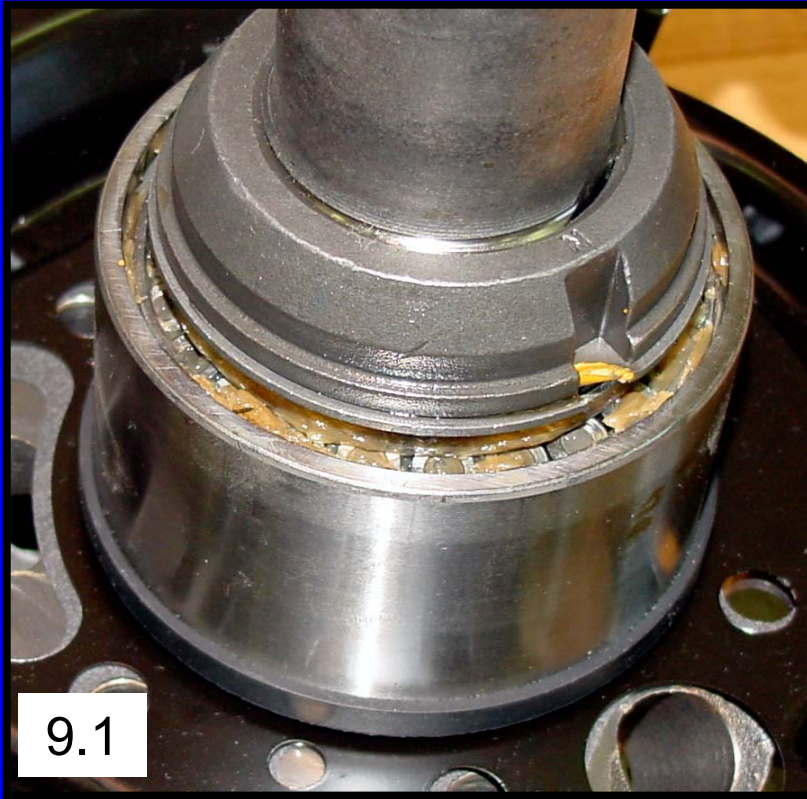

RH thread

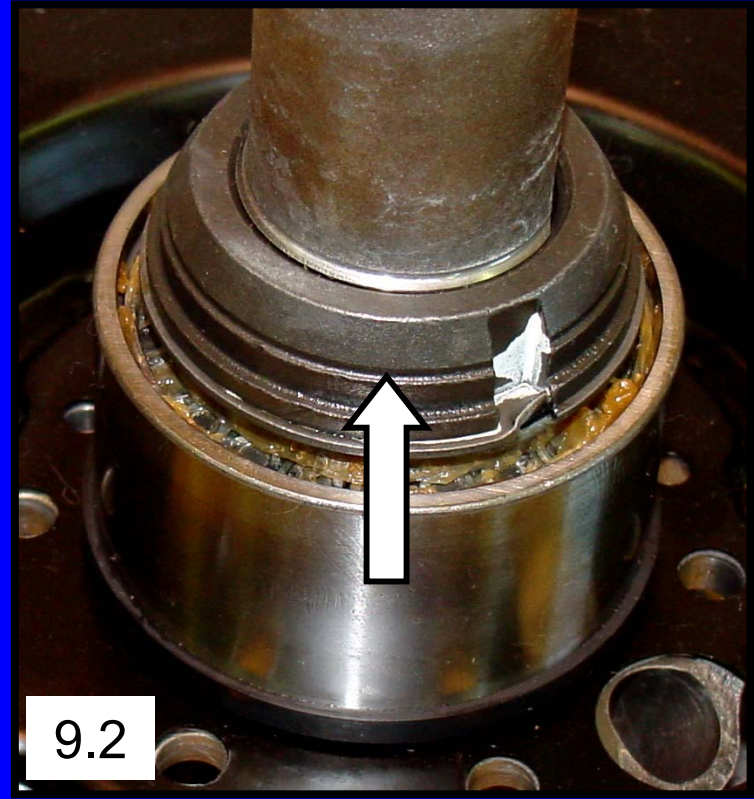

LH thread  
(with groove)

Double tapered roller bearing

# Driveshaft

Repairs to bearings and seals:

- Remove differential lock shift cylinder (left only)
- Remove bearing cap bolts and pull out driveshaft
- Slide special tool for removing grooved nut over driveshaft
- Secure driveshaft in vise
- Unlock & remove grooved nut and locking plate
- Press off roller bearing
- Replace bearing cover seal and gasket
- Reassemble according to WIS ensuring that locking plate is installed correctly

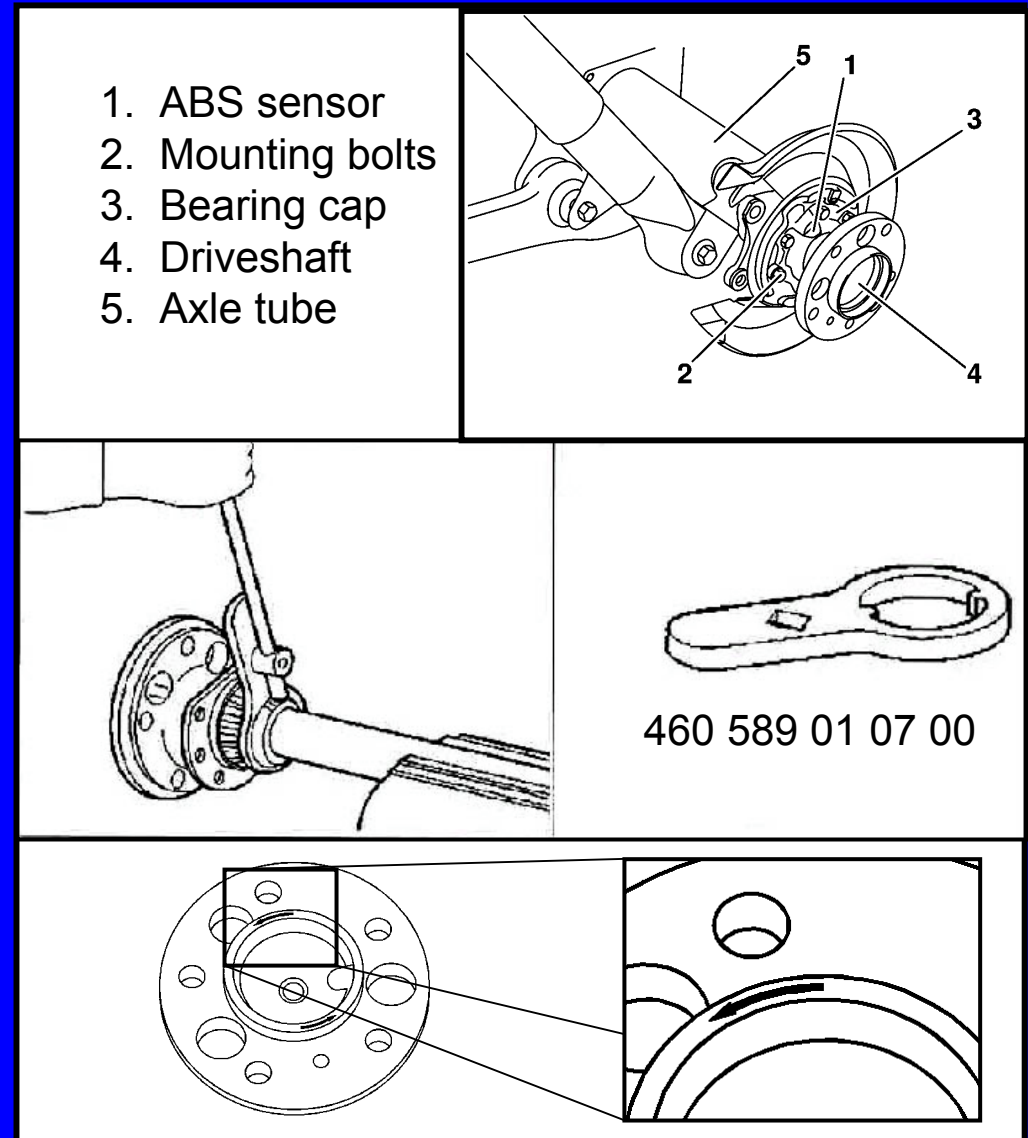

# Driveshaft

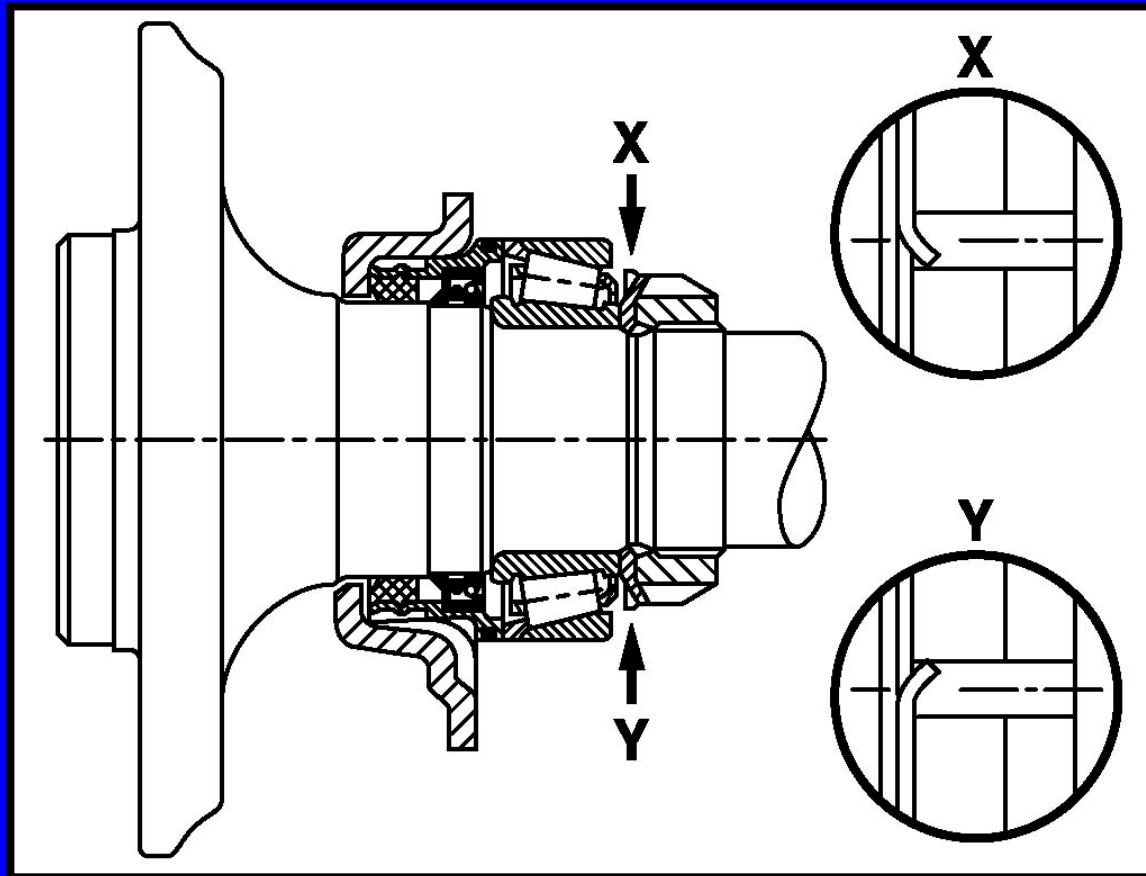

- Torque grooved nut (500Nm) 370 ft lb
- Grooved nut secured with washer to prevent rotation in both directions

# Driveshaft Seals

3. Driveshaft seal

4. Gasket

7. Square seal

