

G&L Pumps

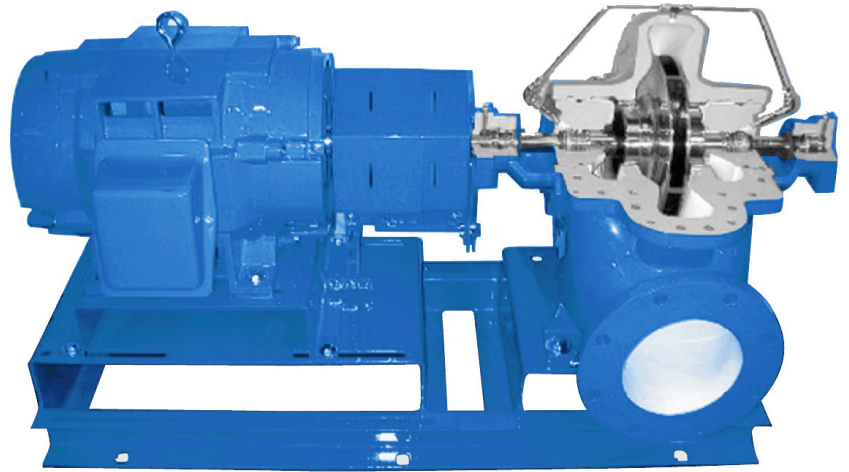

G&L Pumps

Series A-C 8100 - Split Case Pumps Technical Brochure

G&L Pumps

Series A-C 8100

Table of Contents

Useful Pump Formulas	2
Performance Curves	3, 4
Materials of Construction (Standard)	5
Materials of Construction (Optional)	6
Pump Dimensions	7
Typical Specifications	8

Useful Pump Formulas

Pressure (PSI)	=	$\frac{\text{Head (Feet)} \times \text{Specific Gravity}}{2.31}$
Head (Feet)	=	$\frac{\text{Pressure (PSI)} \times 2.31}{\text{Specific Gravity}}$
Vacuum (Inches of Mercury)	=	Dynamic Suction Lift (Feet) x .883 x Specific Gravity
Horsepower (Brake)	=	$\frac{\text{GPM} \times \text{Head (Feet)} \times \text{Specific Gravity}}{3960 \times \text{Pump Efficiency}}$
Horsepower (Water)	=	$\frac{\text{GPM} \times \text{Head (Feet)} \times \text{Specific Gravity}}{3960}$
Efficiency (Pump)	=	$\frac{\text{Horsepower (Water)}}{\text{Horsepower (Brake)}} \times 100 \text{ Per Cent}$
NPSH (Available)	=	Positive Factors – Negative Factors

Affinity Laws: Effect of change of speed or impeller diameter on centrifugal pumps.

	GPM Capacity	Ft. Head	BHP
Impeller Diameter Change	$Q_2 = \frac{D_2}{D_1} Q_1$	$H_2 = \left(\frac{D_2}{D_1}\right)^2 H_1$	$P_2 = \left(\frac{D_2}{D_1}\right)^3 P_1$
Speed Change	$Q_2 = \frac{RPM_2}{RPM_1} Q_1$	$H_2 = \left(\frac{RPM_2}{RPM_1}\right)^2 H_1$	$P_2 = \left(\frac{RPM_2}{RPM_1}\right)^3 P_1$

Where Q = GPM, H = Head, P = BHP, D = Impeller Dia., RPM = Pump Speed

60 Cycle Performance Curves - G&L Pump Series A-C 8100

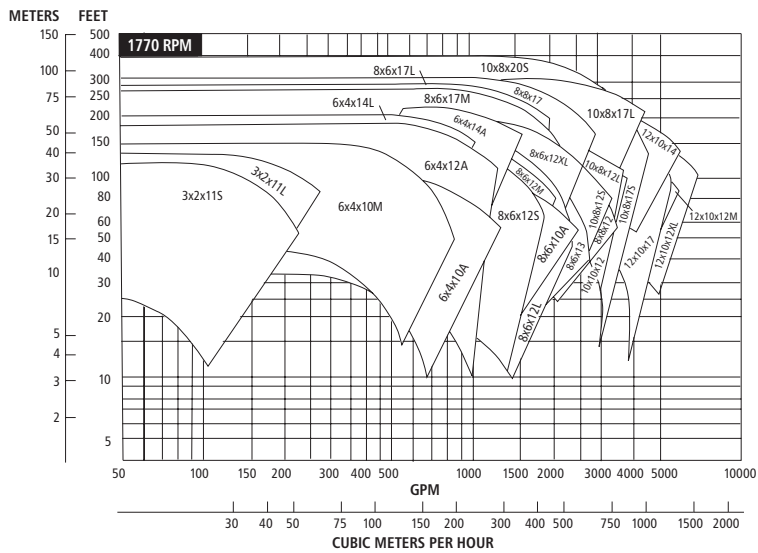
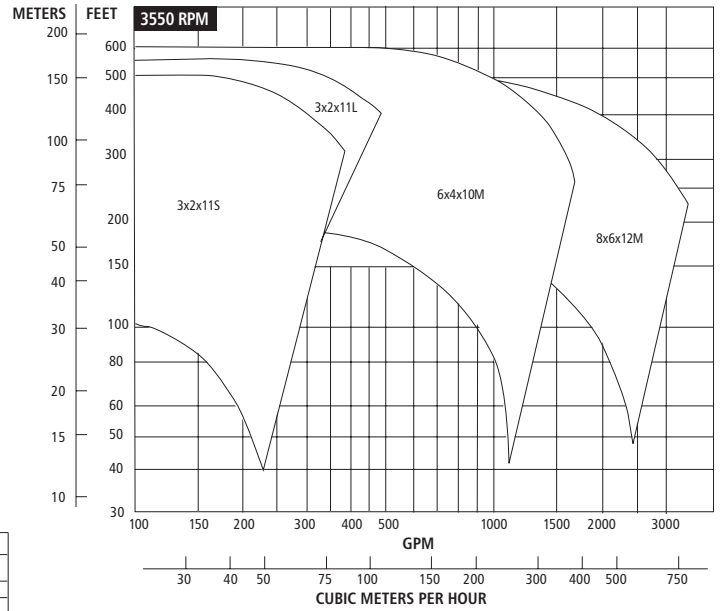
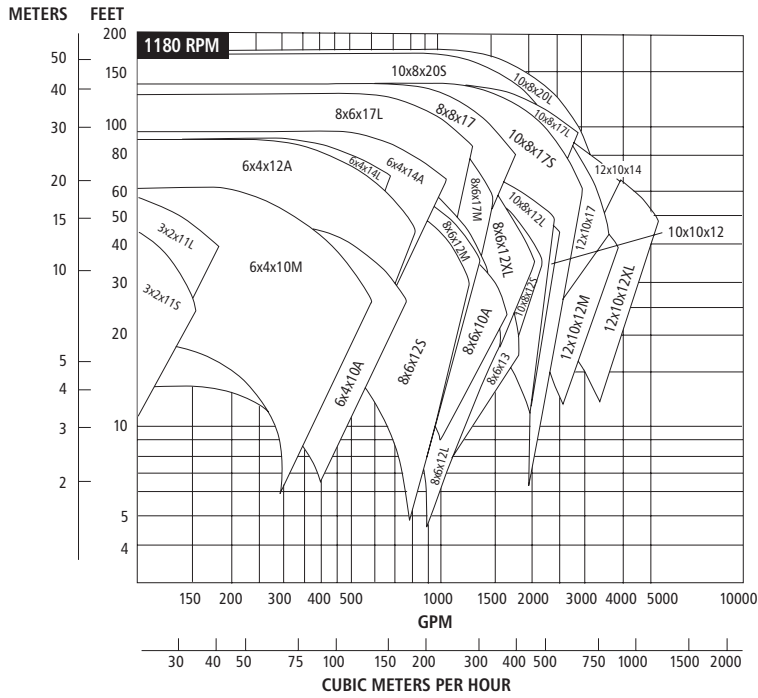

50 Cycle Performance Curves - G&L Pump Series A-C 8100

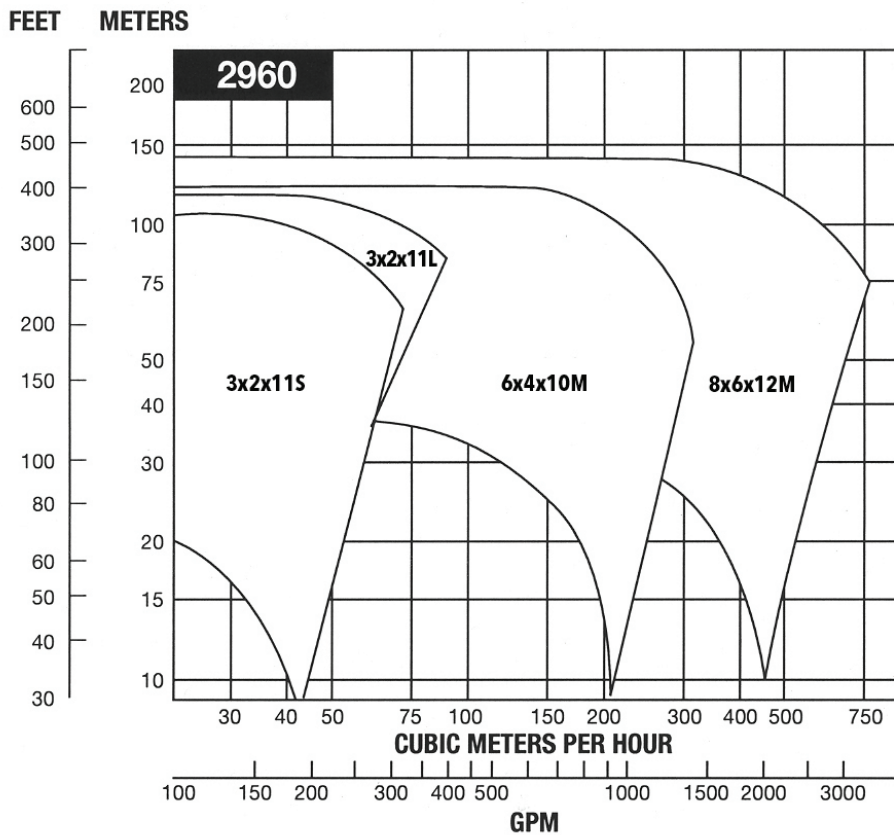
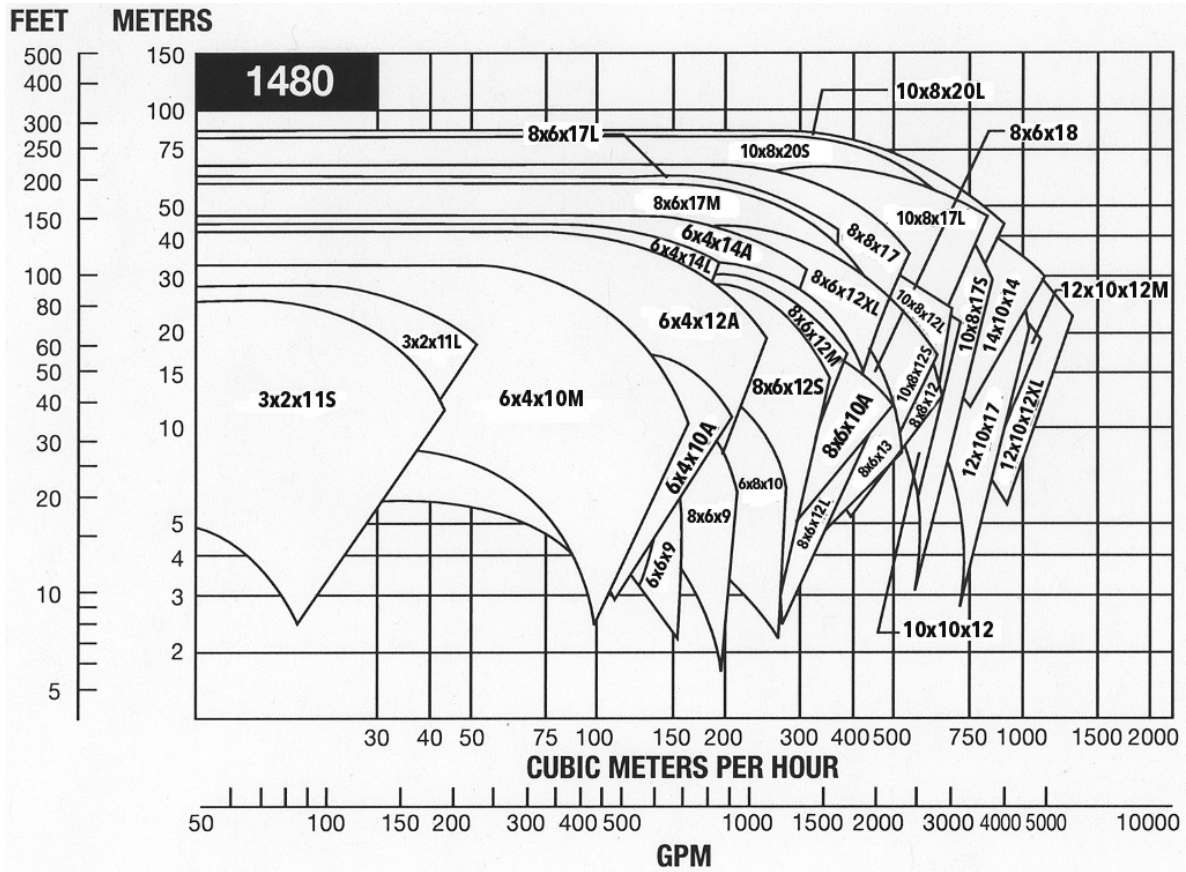

G&L Pump Series A-C 8100 - Materials of Construction

Mechanical Seals Mounted on Shaft

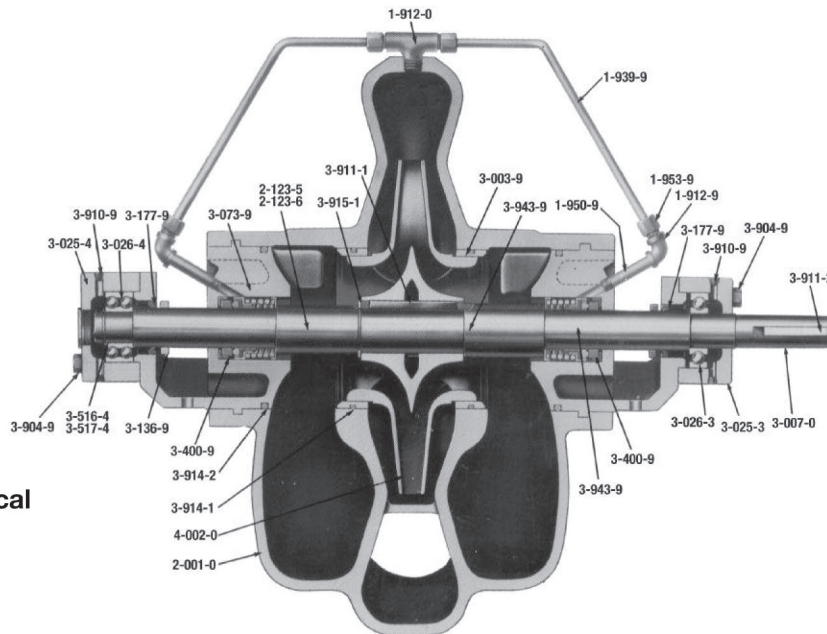

Standard Mechanical Seal with External Seal Piping.

NO.	DESCRIPTION	MATERIAL
		Cast Iron, Bronze Fitted
1-912-0	Pipe Fitting (Casing)	Brass
1-912-9	90° Elbow	Malleable Iron
1-939-9	Tubing	Copper
1-950-9	Nipple	Malleable Iron
1-953-9	Male Connector	Brass
2-001-0	Casing Assembly 2	Cast Iron (ASTM A48 Class 35A)
2-123-5	Casing Joint Gasket (Suction)	Paper (Vellumoid 505)
2-123-6	Casing Joint Gasket (Discharge)	Paper (Vellumoid 505)
3-003-9	Casing Ring	Bronze (ASTM B584-932)
3-007-0	Shaft	416 Stn. Stl.
3-025-3	Bearing Housing	Cast Iron (ASTM A48 Class 25A)
3-025-4	Bearing Housing	Cast Iron (ASTM A48 Class 25A)
3-026-3	Bearing (Inboard) Ball	Steel
3-026-4	Bearing (Outboard) Ball	Steel
3-073-9	Stuffing Box (Mechanical Seal)	Cast Iron (ASTM A48 Class 25A)
3-136-9	Deflector	Rubber (BUNA "N")
3-177-9	Lip Seal (Bearing)	Rubber (BUNA "N")
3-400-9	Mechanical Seal (See copy at right)	Stn. Stl., Rubber, Carbon, Ceramic
3-904-9	Capscrew (Bearing Housing)	Steel, Grade 2
3-910-9	Pipe Plugs (Bearing Housing)	Steel
3-911-1	Key, Impeller	Stn., Stl. (ANSI 416)
3-911-2	Key, Coupling	Steel
3-914-1	"O" Ring (Casing Ring)	Rubber (Buna "N")
3-914-2	"O" Ring (Stuffing Box)	Rubber (Buna "N")
3-915-1	Retaining Ring (Impeller)	Steel
3-516-4	Locknut (Bearing)	Steel
3-517-4	Lockwasher (Bearing)	Steel
3-943-9	Spirol Pin (Stuffing Box) 1	304 SS
3-943-9	Spirol Pin (Casing Ring) 1	304 SS
4-002-0	Impeller	Bronze (ASTM B584-876)

MECHANICAL SEALS

STANDARD CONSTRUCTION:

175 PSIG (12 BAR)
Maximum Working Pressure
*100 PSIG (7 BAR) Maximum Suction Pressure
125#FF ANSI FLANGE (ANSI A21.10, AWWA C110 and ANSI B16.1 class 125)
Type 21, Buna/Carbon-Ceramic, *100 psig (7 BAR) maximum suction pressure, from -20 to 225°F (-29 to 107°C)

Optional Seals:

Type 21, EPR/Carbon-Ceramic, *100 psig (7 BAR) maximum suction pressure, from -20 to 250°F (-29 to 121°C)
Type 21, EPR/Carbon-Tungsten Carbide, *100 psig (7 BAR) maximum suction pressure, from -20 to 250°F (-29 to 121°C)

OPTIONAL CONSTRUCTION:

280 PSIG (19 BAR) Maximum Working Pressure
200 PSIG (13 BAR) Maximum Suction Pressure
250#FF ANSI FLANGE (ANSI B16.1 class 250 except flanges are flat faced)
Type 1, Buna/Carbon-Ceramic, 150 psig (10 BAR) maximum suction pressure, from -20 to 225°F (-29 to 107°C)

Optional Seals:

Type 1, EPR/Carbon-Ceramic, 150 psig (10 BAR) maximum suction pressure, from -20 to 250°F (-29 to 121°C)
Type 1, EPR/Carbon-Tungsten Carbide, 200 psig (13 BAR) maximum suction pressure, from -20 to 250°F (-29 to 121°C)

400 PSIG (27 BAR) Maximum Working Pressure
300 PSIG (20 BAR) Maximum Suction Pressure
250#FF ANSI FLANGE (ANSI B16.1 class 250 except flanges are flat faced)
Type 1B, Buna/Carbon-Ceramic, 300 psig (20 BAR) maximum suction pressure, from -20 to 225°F (-29 to 107°C)

Optional Seals:

Type 1B, EPR/Carbon-Ceramic, 300 psig (20 BAR) maximum suction pressure, from -20 to 250°F (-29 to 121°C)
Type 1B, EPR/Carbon-Tungsten Carbide, 300 psig (20 BAR) maximum suction pressure, from -20 to 250°F (-29 to 121°C)

*Maximum suction pressure for 3500 RPM is 85 psig (6 BAR).

OPTIONAL COMPONENTS*

4-004-9	Rings, Impeller	Bronze (ASTM B505-925)
---------	-----------------	------------------------

*Optional modifications available, if specified, at extra cost.

1 Located at casing parting line.

2 280 and 400 psi 6x8x10A is cast iron.

(Note: Mechanical seals on shaft arrangement not available on pump sizes 6x8x12M, 8x10x20S, and 8x10x20L.)

Note: For pumps with 400 PSI (27 BAR) working pressure, wear ring clearances are doubled. Derate pump efficiencies by 2 percentage points.

G&L Pump Series A-C 8100 - Materials of Construction

Mechanical Seals Mounted on Sleeve

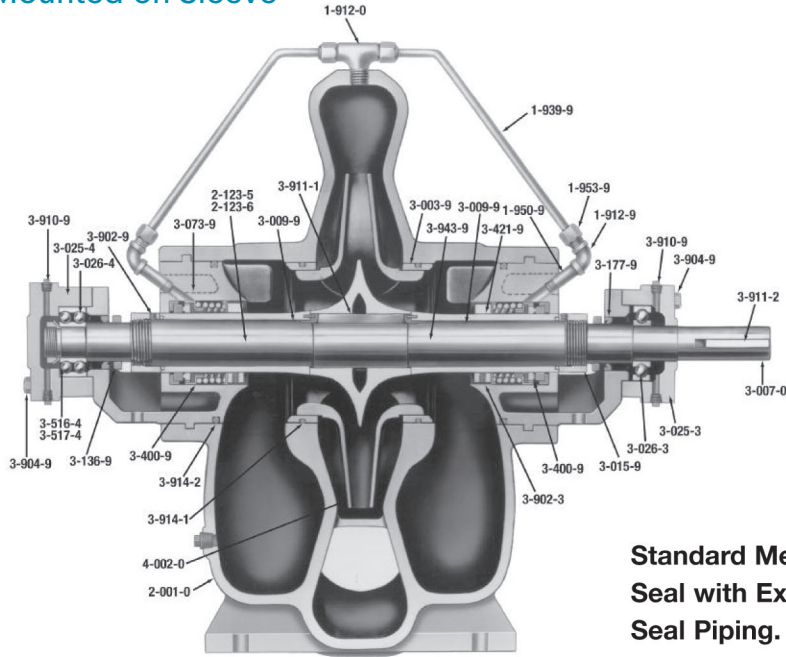

Standard Mechanical Seal with External Seal Piping.

NO.	DESCRIPTION	MATERIAL
		Cast Iron, Bronze Fitted
1-912-0	Pipe Fitting (Casing)	Brass
1-912-9	90° Elbow	Malleable Iron
1-939-9	Tubing	Copper
1-950-9	Nipple	Malleable Iron
1-953-9	Male Connector	Brass
2-001-0	Casing Assembly 3	Cast Iron (ASTM A48 Class 35A)
2-123-5	Casing Joint Gasket (Suction)	Paper (Vellumoid 505)
2-123-6	Casing Joint Gasket (Discharge)	Paper (Vellumoid 505)
3-003-9	Casing Ring	Bronze (ASTM B584-932)
3-007-0	Shaft 4	Steel (SAE 1045)
3-009-9	Shaft Sleeve 5	Bronze (ASTM B584-932)
3-015-9	Shaft Sleeve Nut	Bronze (ASTM B584-932)
3-902-9	Screw, Locking (Set Screw)	Steel
3-025-3	Bearing Housing	Cast Iron (ASTM A48 Class 25A)
3-025-4	Bearing Housing	Cast Iron (ASTM A48 Class 25A)
3-026-3	Bearing (Inboard) Ball	Steel
3-026-4	Bearing (Outboard) Ball	Steel
3-073-9	Stuffing Box (Mechanical Seal)	Cast Iron (ASTM A48 Class 25A)
3-136-9	Deflector	Rubber (BUNA "N")
3-177-9	Lip Seal (Bearing)	Rubber (BUNA "N")
3-400-9	Mechanical Seal (See copy at right)	Strn. Stl., Rubber, Carbon, Ceramic
3-421-9	Set Collar	Bronze (ASTM B584-932)
3-902-3	Set Screw	304 SS
3-904-9	Capscrew (Bearing Housing)	Steel, Grade 2
3-910-9	Pipe Plugs (Bearing Housing)	Steel
3-911-1	Key, Impeller	Steel
3-911-2	Key, Coupling	Steel
3-914-1	"O" Ring (Casing Ring)	Rubber (Buna "N")
3-914-2	"O" Ring (Stuffing Box)	Rubber (Buna "N")
3-516-4	Locknut (Bearing)	Steel
3-517-4	Lockwasher (Bearing)	Steel
3-943-9	Spirol Pin (Stuffing Box) 1	304 SS
3-943-9	Spirol Pin (Casing Ring) 1	304 SS
4-002-0	Impeller	Bronze (ASTM B584-876)
OPTIONAL COMPONENTS*		
4-004-9	Rings, Impeller	Bronze (ASTM B505-925)
3-400-9	Mechanical Seal Balanced	Strn. Stl., Rubber, Carbon, Ceramic

MECHANICAL SEALS

STANDARD CONSTRUCTION:

175 PSIG (12 BAR)
 Maximum Working Pressure
 *100 PSIG (7 BAR) Maximum Suction Pressure
 125#FF ANSI FLANGE (ANSI A21.10, AWWA C110 and ANSI B16.1 class 125)
 Type 21, Buna/Carbon-Ceramic, *100 psig (7 BAR) maximum suction pressure, from -20 to 225°F (-29 to 107°C)

Optional Seals:

Type 21, EPR/Carbon-Ceramic, *100 psig (7 BAR) maximum suction pressure, from -20 to 250°F (-29 to 121°C)
 Type 21, EPR/Carbon-Tungsten Carbide, *100 psig (7 BAR) maximum suction pressure, from -20 to 250°F (-29 to 121°C)
 Packing, *100 psig (7 BAR) maximum working pressure, 0 to 225°F (-18 to 107°C)

OPTIONAL CONSTRUCTION:

280 PSIG (19 BAR) Maximum Working Pressure
 200 PSIG (13 BAR) Maximum Suction Pressure
 250#FF ANSI FLANGE (ANSI B16.1 class 250 except flanges are flat faced)
 Type 1, Buna/Carbon-Ceramic, 150 psig (10 BAR) maximum suction pressure, from -20 to 225°F (-29 to 107°C)

Optional Seals:

Type 1, EPR/Carbon-Ceramic, 150 psig (10 BAR) maximum suction pressure, from -20 to 250°F (-29 to 121°C)
 Type 1, EPR/Carbon-Tungsten Carbide, 200 psig (13 BAR) maximum suction pressure, from -20 to 250°F (-29 to 121°C)

400 PSIG (27 BAR) Maximum Working Pressure
 300 PSIG (20 BAR) Maximum Suction Pressure
 250#FF ANSI FLANGE (ANSI B16.1 class 250 except flanges are flat faced)
 Type 1B, Buna/Carbon-Ceramic, 300 psig (20 BAR) maximum suction pressure, from -20 to 225°F (-29 to 107°C)

Optional Seals:

Type 1B, EPR/Carbon-Ceramic, 300 psig (20 BAR) maximum suction pressure, from -20 to 250°F (-29 to 121°C)
 Type 1B, EPR/Carbon-Tungsten Carbide, 300 psig (20 BAR) maximum suction pressure, from -20 to 250°F (-29 to 121°C)

*Maximum suction pressure for 3500 RPM is 85 psig (6 BAR).

*Optional modifications available, if specified, at extra cost.
 1 Located at casing parting line.
 3 For 280 (19 BAR) and 400 (27 BAR) psi working pressures, casing materials is Ductile iron (ASTM A536, Grade 65-45-12).
 4 Shaft material AISI 4140 on pump 4x6x11, 6x8x12M, 8x10x20S, 8x10x20L.

5 Mechanical seal on sleeve or packing not available for pump size 6x8x10A.

Note: For pumps with 400 PSI (27 BAR) working pressure, wear ring clearances are doubled. Derate pump efficiencies by 2 percentage points.

G&L Pump Series A-C 8100 - Model 150 Dimensions

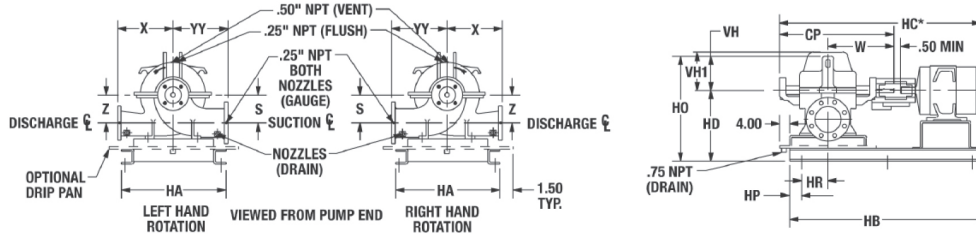

STANDARD: 125#FF ANSI FLANGE (ANSI A21.10, AWWA C110 & ANSI B16.1 CLASS 125)
 OPTIONAL: 250#FF ANSI FLANGE (ANSI B16.1 CLASS 250 EXCEPT FLANGES ARE FLAT FACED)
 VH1 APPLIES TO 280 & 400 PSIG RIBBED CASINGS
 DIMENSIONS ARE SUBJECT TO CHANGE. NOT TO BE USED FOR CONSTRUCTION PURPOSES UNLESS CERTIFIED.
 *MOTOR DIMENSIONS ARE APPROXIMATE FOR "T" FRAMES, VARY BY MANUFACTURER AND MOTOR TYPE.

PUMP SIZE	MOTOR FRAME	DIMENSIONS - INCHES (MM)														
		HA	HB	HP	HR	CP	HC*MAX	HD	HO	S & Z	VH	VH1	W	X	YY	
3x2x11 S, L	143-215	20.00	48.00 (1219)	6.00	2.25	28.25	47 (1194)	15.25 (388)	22.05 (560)	5.50 (140)	6.80 (173)	-	16.00 (406)	9.00 (229)	10.00 (254)	
	254-365	(508)	54.00 (1372)	(152)	(57)	(718)	61 (1549)									
6x4x10A	182-215	21.50	48.00 (1219)	6.00	2.88	30.06	60 (1524)	18.25 (464)	25.94 (656)	7.00 (178)	7.69 (195)	-	17.25 (438)	11.50 (292)	12.00 (305)	
	254-324	(546)	60.00 (1524)	(152)	(73)	(764)	69 (1753)									
6x4x10M	182-215	24.00	48.00 (1219)	6.00	4.62	33.12	53 (1346)	18.25 (464)	26.12 (664)	6.50 (165)	7.88 (200)	-	18.50 (470)	11.50 (292)	13.00 (330)	
	254-326		58.00 (1473)				63 (1600)									
	364-405		64.00 (1626)				72 (1829)									
	444-445		76.00 (1930)				78 (1981)									
6x4x12A	215	24.00	48.00 (1219)	6.00	4.62	33.12	53 (1346)	18.25 (464)	26.12 (664)	6.50 (165)	7.88 (200)	-	18.5 (470)	11.50 (292)	13.00 (330)	
	254-326		58.00 (1473)				63 (1600)									
	364-365		64.00 (1626)				66 (1677)									
6x4x14A	215-256	24.00	50.00 (1270)	6.00	3.25	30.75	55 (1397)	19.52 (489)	28.50 (723)	7.75 (197)	9.20 (234)	-	17.50 (445)	11.50 (292)	13.00 (330)	
	284-365		58.00 (1473)				64 (1626)									
	404-405		68.00 (1727)				70 (1788)									
	444		76.00 (1930)				74 (1880)									
6x4x14L	182-256	24.00	50.00 (1270)	6.00	3.25	30.75	55 (1397)	19.25 (489)	28.87 (733)	7.75 (197)	9.62 (244)	-	17.50 (445)	11.50 (292)	13.00 (330)	
	284-365		58.00 (1473)				64 (1626)									
8x6x10A	215	24.00	58.00 (1473)	6.00	10.75	40.00	60.25 (1530)	21.25 (540)	30.50 (775)	8.25 (210)	9.25 (235)	-	23.00 (584)	12.50 (318)	12.50 (318)	
	254-326		64.00 (1626)				69.25 (1759)									
	364-365		68.00 (1727)				71.25 (1810)									
8x6x12 S, L, XL	182-215	21.50	48.00 (1219)	6.00	3.25	30.75	51 (1296)	21.25 (540)	30.85 (784)	9.00 (229)	9.60 (244)	-	17.50 (445)	14.00 (356)	14.00 (356)	
	254-326		54.00 (1372)				61 (1549)									
	364-365		60.00 (1524)				64 (1626)									
8x6x12M	254-326	24.00	58.00 (1473)	6.00	4.63	33.12	63 (1600)	21.25 (540)	30.85 (784)	9.00 (229)	9.60 (244)	-	18.50 (470)	14.00 (356)	14.00 (356)	
	364-405		64.00 (1626)				72 (1829)									
	444-447		76.00 (1930)				81 (2058)									
8x6x13	254-326	24.00	62.00 (1575)	6.00	5.63	36.87	67 (1702)	20.00 (508)	29.40 (747)	8.00 (203)	9.40 (239)	-	21.25 (540)	13.00 (330)	15.50 (394)	
	364-405		68.00 (1727)				76 (1930)									
8x6x17 M, L	284-326	24.00	62.00 (1575)	6.00	5.63	36.87	67 (1702)	21.25 (540)	33.00 (838)	9.00 (229)	11.75 (299)	-	21.25 (540)	14.00 (356)	16.00 (406)	
	364-405		68.00 (1727)				76 (1930)									
	444-445		76.00 (1930)				82 (2083)									
8x8x12	254-326	24.00	62.00 (1575)	6.00	5.63	36.87	67 (1702)	20.00 (508)	30.25 (768)	8.00 (203)	10.25 (260)	11.75 (299)	21.25 (540)	14.00 (356)	16.50 (419)	
	364-405		68.00 (1727)				76 (1930)									
8x8x17	324-365	24.00	66.00 (1676)	6.00	7.00	39.56	72 (1829)	23.75 (603)	35.75 (908)	9.50 (241)	12.00 (305)	13.50 (343)	22.56 (573)	15.00 (381)	16.50 (419)	
	404-445		76.00 (1930)				8.00 (1005)									
	447-449		86.00 (2184)				8.00 (203)									
10x8x12 S, L	254-286	24	62.00 (1575)	6.00	7.00	39.56	67 (1702)	21.50 (546)	32.00 (813)	8.50 (216)	10.50 (267)	12.00 (305)	22.56 (573)	14.00 (356)	17.00 (432)	
	324-365		66.00 (1676)				8.00 (203)									
	404-445		76.00 (1930)				8.00 (203)									
10x8x17 S, L	324-365	24	66.00 (1676)	6.00	7.00	39.56	72 (1829)	23.25 (591)	36.06 (916)	10.00 (254)	12.81 (325)	14.31 (363)	22.56 (573)	16.00 (406)	18.00 (457)	
	404-445		76.00 (1930)				8.00 (1005)									
	447-449		86.00 (2184)				8.00 (203)									
10x8x20 S, L	324-365	26.00	66.00 (1676)	6.00	7.00	39.56	72 (1829)	27.25 (692)	49.50 (1257)	14.00 (356)	15.44 (392)	22.25 (565)	22.56 (573)	18.00 (457)	20.00 (508)	
	404-445		31.40				76.00 (1930)									8.00 (203)
	447-449		(798)				86.00 (2184)									(127)
10x10x12	284-365	24.00	68.00 (1727)	6.00	8.50	42.56	75 (1905)	22.50 (572)	33.69 (856)	9.00 (229)	11.19 (284)	-	24.06 (611)	16.00 (406)	18.00 (457)	
	404-445		80.00 (2032)				9.50 (241)									
12x10x12 M, XL	284-365	24.00	68.00 (1727)	6.00	8.50	42.56	75 (1905)	24.50 (622)	36.00 (914)	10.00 (254)	11.50 (292)	-	24.06 (611)	16.00 (406)	19.00 (483)	
	404-445		80.00 (2032)				9.50 (241)									
12x10x14	324-365	24.00	66.00 (1676)	6.00	7.00	39.56	72 (1829)	25.25 (641)	38.69 (983)	11.00 (280)	13.44 (341)	14.94 (380)	22.56 (573)	18.00 (457)	20.00 (508)	
	404-445		29.40				76.00 (1930)									8.00 (203)
	447-449		(747)				86.00 (2184)									(127)
12x10x17	324-365	24.00	66.00 (1676)	6.00	7.00	39.56	72 (1829)	25.25 (641)	38.69 (983)	11.00 (280)	13.44 (341)	14.94 (380)	22.56 (573)	18.00 (457)	20.00 (508)	
	404-445		29.40				76.00 (1930)									8.00 (203)
	447-449		(747)				86.00 (2184)									(127)

Not for construction unless certified.

Typical Specifications for G&L Pump Series A-C 8100 Horizontal Split Case Pumps

Specifications

2.01 DOUBLE SUCTION, HORIZONTAL SPLIT CASE PUMPS (BASE MOUNTED)

A MANUFACTURER:

Contractor shall furnish and install new double suction horizontal split case pumps for chilled water and hot water heating systems as indicated on the drawings. Pumps shall be model G&L Pump Series A-C 8100 under base bid. Equivalent units may be submitted as deduct alternates. Pumps shall meet types, sizes, capacities, and characteristics as scheduled on the Equipment Schedule drawings.

B DOUBLE SUCTION, HORIZONTAL SPLIT CASE PUMP (BASE MOUNTED) :

1. The pumps shall be long coupled, base mounted, single stage, double suction, horizontally split case design, in cast iron bronze fitted construction specifically designed and guaranteed for quiet operation. Suitable standard operations at 225°F (107°C) and 175 psig (12 BAR) working pressure or optional operations at up to 250°F (121°C) and 280 (19 BAR) or 400 psig (27 BAR) working pressures. Working pressures shall not be de-rated at temperatures up to 250°F (121°C). The pump internals shall be capable of being serviced without disturbing piping connections or electrical motor connections.
2. A bearing housing shall supply support for a pair of heavy-duty regreaseable ball bearings. An inboard single row bearing will absorb thermal expansive forces while an outboard double row bearing will be clamped in place to absorb both radial and thrust loads and keep the rotating element in proper axial alignment. Bearings shall be replaceable without disturbing the system piping and shall be regreaseable without removal of the bearings from the bearing housing.
3. The impeller shaft shall be a solid 416 stainless steel shaft.
4. Pump shall be equipped with a pair of externally flushed mechanical seal assemblies in direct contact with the pump shaft. Seal assemblies shall be a Type 21 having a stainless steel housing, Buna bellows and seat gasket, stainless steel spring, and be of a carbon-ceramic design with the carbon face rotating against a stationary ceramic face.
5. Impeller shall be of the enclosed double suction type made of bronze, both hydraulically and dynamically balanced to ANSI/HI 1.1-1.5-1994, section 1.4.6.1.3.1, figure 1.106, balance grade G6.3 keyed to the shaft and fixed in the axial position.
6. A center drop-out type coupling, capable of absorbing torsional vibration, shall be employed between the pump and motor. On variable speed applications the coupler sleeve should be constructed of an EPDM material to maximize performance life.
7. The coupling shall be shielded by a dual rated ANSI B15.1, Section 8 and OSHA 1910.219 compliant coupling guard and contain viewing windows for inspection of the coupling.
8. Pump volute shall be of a cast iron (rated for 175 psig [12 BAR] Max WP) or ductile iron (rated for 280 [19 BAR] or 400 psig [27 BAR] Max WP) axially-split design with flanges (175 psig [12 BAR] drilled for 125# ANSI companion flanges or optional 280 [19 BAR] and 400 psig [27 BAR] working pressures are drilled 250# flange drilled) and mounting feet integral cast into the bottom half of the casing. 280 (19 BAR) and 400 psig (27 BAR) 6x8x10A's are cast iron. Suction and discharge flanges shall be on a common centerline in both the horizontal and vertical planes, and the volute shall include Bronze Casing Wear Rings, priming port, gauge ports at nozzles, and vent and drain ports. The upper half casing shall be capable of being removed without disturbing piping connections or electrical motor connections.
9. Pump seal flushing lines shall be mounted on the upper half pump casing. Sealing from an external source shall be possible for lubrication and/or cooling.
10. Pump and motors shall be factory aligned, and shall be realigned after installation by the manufacturer's representative. Motors shall be of electrical characteristics as scheduled, denoted and/or as indicated on the electrical plans and specifications. Pump characteristics shall be such that the head of the pump under varying conditions shall not exceed the rated horsepower of the drive motor.
11. Base plate shall be of structural steel or fabricated steel channel with fully enclosed sides and ends, and securely welded cross members. Grouting area shall be fully open. The combined pump and motor base plate shall be sufficiently stiff as to limit the susceptibility of vibration. The minimum base plate stiffness shall conform to ANSI/HI 1.3.4-1997 for Horizontal Baseplate Design standards.
12. Base shall be capable of being field grouted.
13. The pump(s) selected shall conform to ANSI/HI 9.6.3.1 standards for Preferred Operating Region (POR) unless otherwise approved by the engineer. The pump NPSH shall conform to the ANSI/HI 9.6.1-1997 standards for Centrifugal and Vertical Pumps for NPSH Margin.
14. Pump rotation shall be righthand or lefthand as viewed from the pump end.
15. Pump manufacturer shall be ISO-9001 certified.
16. The seismic capability of the pump shall allow it to withstand a horizontal load of 0.5g, excluding piping and/or fasteners used to anchor the pump to mounting pads or to the floor, without adversely affecting pump operation.
17. Each pump shall be factory hydrostatically tested per Hydraulic Institute standards and name-plated before shipment. It shall then be thoroughly cleaned and painted with at least one coat of high-grade paint prior to shipment.
18. Pumps shall be Series A-C 8100 as manufactured by G&L Pumps or approved equal.



Xylem Inc.
8200 N. Austin Avenue
Morton Grove, Illinois 60053
Phone: (847) 966-3700
Fax: (847) 965-8379
www.xyleminc.com