



9 Maintenance

Introduction to Maintenance	166
Warnings and Cautions	167
Overview of Maintenance	169
Cleaning the Module	170
Exchanging a Flow Cell	171
How to use the Cuvette	175
Flow Cell Flushing	176
Correcting Leaks	177
Replacing Leak Handling System Parts	178
Replacing the Interface Board	179
Replacing Module Firmware	180
Tests and Calibrations	181

This chapter provides general information on maintenance of the detector.



Introduction to Maintenance

The module is designed for easy maintenance. Maintenance can be done from the front with module in place in the system stack.

NOTE

There are no serviceable parts inside.
Do not open the module.

Warnings and Cautions

WARNING

Toxic, flammable and hazardous solvents, samples and reagents

The handling of solvents, samples and reagents can hold health and safety risks.

- When working with these substances observe appropriate safety procedures (for example by wearing goggles, safety gloves and protective clothing) as described in the material handling and safety data sheet supplied by the vendor, and follow good laboratory practice.
 - The volume of substances should be reduced to the minimum required for the analysis.
 - Do not operate the instrument in an explosive atmosphere.
-

WARNING

Eye damage by detector light



Eye damage may result from directly viewing the UV-light produced by the lamp of the optical system used in this product.

- Always turn the lamp of the optical system off before removing it.
-

WARNING

Electrical shock

Repair work at the module can lead to personal injuries, e.g. shock hazard, when the cover is opened.

- Do not remove the cover of the module.
 - Only certified persons are authorized to carry out repairs inside the module.
-

WARNING

Personal injury or damage to the product

Agilent is not responsible for any damages caused, in whole or in part, by improper use of the products, unauthorized alterations, adjustments or modifications to the products, failure to comply with procedures in Agilent product user guides, or use of the products in violation of applicable laws, rules or regulations.

- Use your Agilent products only in the manner described in the Agilent product user guides.
-

CAUTION

Safety standards for external equipment

- If you connect external equipment to the instrument, make sure that you only use accessory units tested and approved according to the safety standards appropriate for the type of external equipment.
-

Overview of Maintenance

The following pages describe maintenance (simple repairs) of the detector that can be carried out without opening the main cover.

Table 28 Simple Repairs

Procedure	Typical Frequency	Notes
Flow cell exchange	If application requires a different flow cell type or if defective.	Complete Assembly A wavelength calibration check should be performed after replacement. If the flow cell is removed and inserted, then a quick calibration check is performed. If this fails, you must do a wavelength recalibration, see " Wavelength Verification and Calibration " on page 151.
Flow cell flushing	If flow cell is contaminated.	
Leak sensor drying	If leak has occurred.	Check for leaks.
Leak handling System replacement	If broken or corroded.	Check for leaks.

Cleaning the Module

To keep the module case clean, use a soft cloth slightly dampened with water, or a solution of water and mild detergent.

WARNING

Liquid dripping into the electronic compartment of your module can cause shock hazard and damage the module

- Do not use an excessively damp cloth during cleaning.
 - Drain all solvent lines before opening any connections in the flow path.
-

Exchanging a Flow Cell



For bio-inert modules use bio-inert parts only!

When If an application needs a different type of flow cell or the flow cell is defective (leaky).

Tools required **Description**
Wrench, 1/4 inch
for capillary connections

Parts required	#	p/n	Description
	1	G1321-60005	Flow cell, 8 μ L, 20 bar (pH 1 – 9.5)
	1	G1321-60015	Flow cell, 4 μ L, 20 bar (pH 1 – 9.5)
	1	G5615-60005	Bio-inert flow cell, 8 μ L, 20 bar (pH 1–12) includes Capillary Kit Flow Cells BIO (p/n G5615-68755)
	1	G1321-60007	FLD Cuvette Kit, 8 μ L, 20 bar

Preparations Turn off the flow.

CAUTION

Sample degradation and contamination of the instrument

Metal parts in the flow path can interact with the bio-molecules in the sample leading to sample degradation and contamination.

- For bio-inert applications, always use dedicated bio-inert parts, which can be identified by the bio-inert symbol or other markers described in this manual.
- Do not mix bio-inert and non-inert modules or parts in a bio-inert system.

NOTE

DO NOT install the inlet capillary to the outlet connection of the flow cell. This will result in poor performance.

NOTE

In case the flow cell is not used for some time (stored), then flush the flow cell with iso-propanol and close the cell with Plug-Screw (0100-1259).

9 Maintenance

Exchanging a Flow Cell

1 Press the release buttons and remove the front cover for access to the flow cell area.

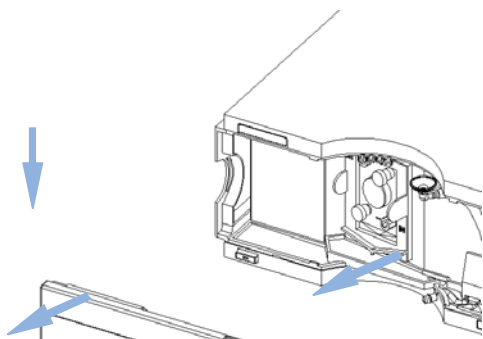

2 Disconnect the capillaries from the flow cell.

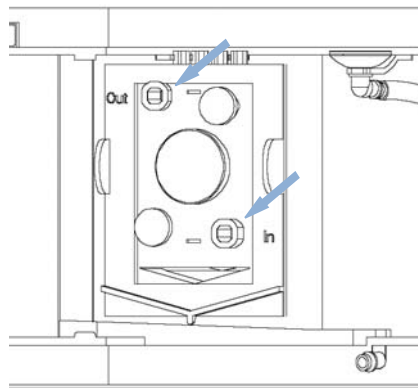

- 3** Unscrew the thumb screws and pull the flow cell out of the compartment.

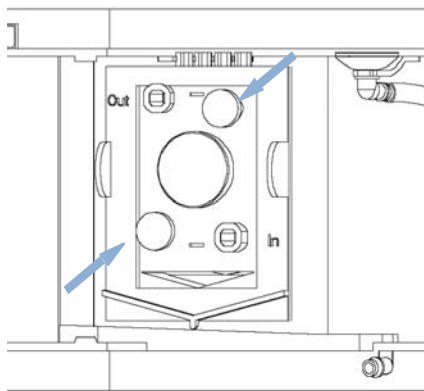

NOTE

The label attached to the flow cell provides information on part number, cell volume and maximum pressure. The cell type will be automatically detected.

There are no parts that can be replaced on the flow cell. If defective (leaky) the flow cell has to be replaced completely.

- 4** Insert the flow cell and tighten the thumb screws. Reconnect the capillaries to the flow cell. **DO NOT** install the inlet capillary to the outlet connection of the flow cell. This will result in poor performance or damage.

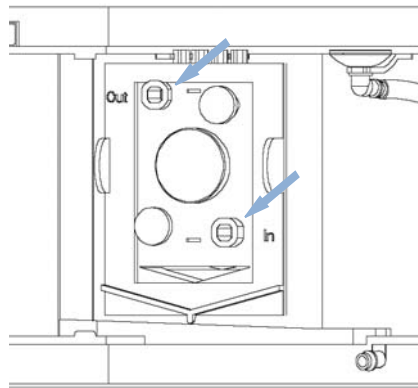

NOTE

If an additional detector is added to the system, the fluorescence detector should be the last detector in the flow path except for evaporative detectors, like LC-MSD. Otherwise the back pressure generated by the other detector may overload the flow cell and will lead to a defective cell (maximum pressure is 20 bar (2 MPa)).

Always use the outlet capillary set supplied with the accessory kit.

NOTE

To check for leaks, establish a flow and observe the flow cell (outside of the cell compartment) and all capillary connections.

9 Maintenance

Exchanging a Flow Cell

- 5 Replace the front cover.

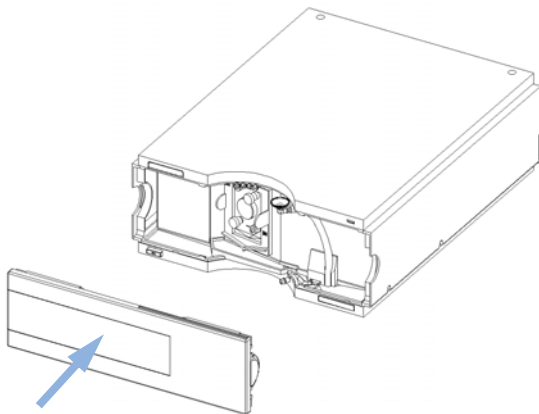

NOTE

Perform a wavelength verification to check the correct positioning of the flow cell, as described in chapter [“Wavelength Verification and Calibration”](#) on page 151.

How to use the Cuvette

The cuvette is used for off-line measurements (no flow system required) and is basically a standard flow cell with a few changes:

- wide bore capillary connections for easier injections with a syringe
 - identification lever for cell auto-recognition system.
- 1** Install the cuvette instead of the standard flow cell.
 - 2** Connect the waste tubing to the outlet of the cuvette.
 - 3** Use the syringe (see “[Cuvette Kit](#)” on page 185) to inject the compound.
 - 4** Setup the parameters for the Fluorescence Scan (under Special Setpoints).
 - 5** Select “Take Fluorescence Scan” on the user-interface to start the off-line measurement.

Flow Cell Flushing

When If flow cell is contaminated

Tools required

Description
Glass syringe
Adapter

Parts required

#	Description
1	Bidistilled water, nitric acid (65%), tubings to waste

WARNING

Dangerous concentration of nitric acid

The nitric acid flushing procedure is not an infallible remedy for a dirty cell. It is to be used as a last attempt to salvage the cell before cell replacement. Note that the cell is a consumable item.

→ Give proper attention to safety.

NOTE

Aqueous solvents in the flow cell can build up algae. Algae do fluoresce. Therefore do not leave aqueous solvents in the flow cell for longer periods. Add a small percentage of organic solvents (e.g. Acetonitrile or Methanol ~5 %).

- 1 Flush with bidistilled water.
- 2 Flush with nitric acid (65 %) using a glass syringe.
- 3 Leave this solution in the cell for about one hour.
- 4 Flush with bidistilled water.

NOTE

Do not exceed the pressure limit of 20 bar (0.2 MPa).

Correcting Leaks

When If a leakage has occurred in the flow cell area or at the capillary connections

Tools required

Description
Tissue
Wrench, 1/4 inch
for capillary connections

- 1 Remove the front cover.
- 2 Use tissue to dry the leak sensor area and the leak pan.
- 3 Observe the capillary connections and the flow cell area for leaks and correct, if required.
- 4 Replace the front cover.

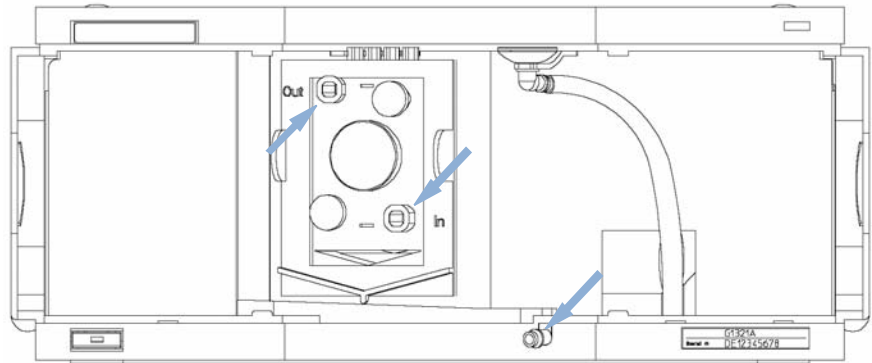

Figure 67 Observing for Leaks

Replacing Leak Handling System Parts

When If the parts are corroded or broken

Parts required	#	p/n	Description
	1	5041-8389	Leak funnel
	1	5061-3356	Leak funnel holder
	1	5042-9974	Leak tubing (1.5 m, 120 mm required)

- 1 Remove the front cover.
- 2 Pull the leak funnel out of the leak funnel holder.
- 3 Pull out the leak funnel with the tubing.
- 4 Insert the leak funnel with the tubing in its position.
- 5 Insert the leak funnel into the leak funnel holder.
- 6 Replace the front cover.

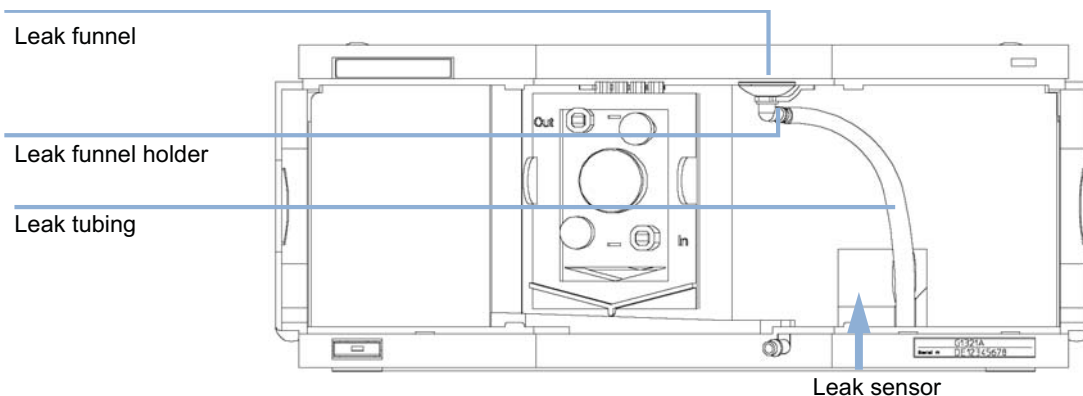

Figure 68 Replacing Leak Handling System Parts

Replacing the Interface Board

When For all repairs inside the detector or for installation of the board

Parts required	#	p/n	Description
	1	G1351-68701	Interface board (BCD) with external contacts and BCD outputs
	1	G1369B or G1369-60002	Interface board (LAN)
OR	1	G1369C or G1369-60012	Interface board (LAN)

- 1 To replace the interface board unscrew the two screws, remove the board, slide in the new interface board and fix it with the board's screws.

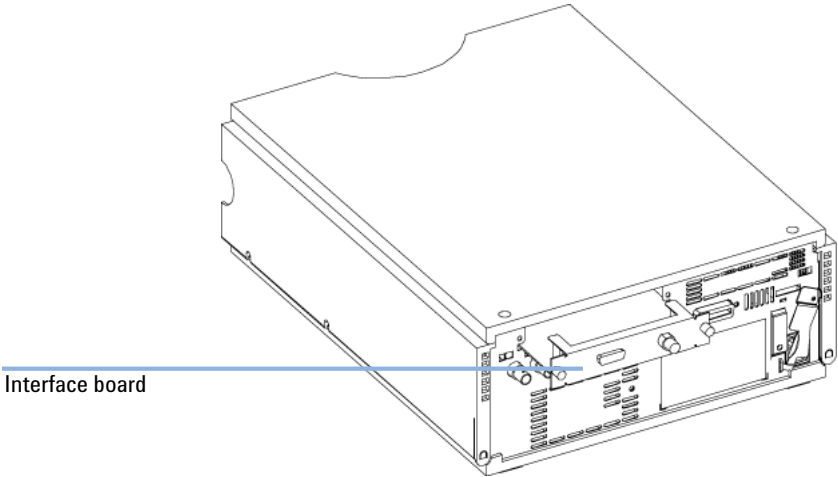

Figure 69 Location of the Interface Board

Replacing Module Firmware

When	The installation of newer firmware might be necessary <ul style="list-style-type: none">• if a newer version solves problems of older versions or• to keep all systems on the same (validated) revision. The installation of older firmware might be necessary <ul style="list-style-type: none">• to keep all systems on the same (validated) revision or• if a new module with newer firmware is added to a system or• if third party control software requires a special version.
-------------	---

Tools required	Description
	LAN/RS-232 Firmware Update Tool
OR	Agilent Lab Advisor software
OR	Instant Pilot G4208A (only if supported by module)

Parts required	#	Description
	1	Firmware, tools and documentation from Agilent web site

Preparations Read update documentation provided with the Firmware Update Tool.

To upgrade/downgrade the module's firmware carry out the following steps:

- 1 Download the required module firmware, the latest LAN/RS-232 FW Update Tool and the documentation from the Agilent web.
 - http://www.chem.agilent.com/_layouts/agilent/downloadFirmware.aspx?whid=69761
- 2 For loading the firmware into the module follow the instructions in the documentation.

Module Specific Information

There is no specific information for this module.

Tests and Calibrations

The following tests are required after maintenance of lamps and flow cells:

- [“Lamp Intensity Test”](#) on page 140.
- [“Wavelength Verification and Calibration”](#) on page 151

9 Maintenance
Tests and Calibrations



10 Parts for Maintenance

Overview of Maintenance Parts [184](#)

Cuvette Kit [185](#)

Accessory Kit [186](#)

This chapter provides information on parts for maintenance.



Overview of Maintenance Parts

p/n	Description
G1321-60005	Flow cell, 8 μ L, 20 bar (pH 1 – 9.5)
OR G1321-60015	Flow cell, 4 μ L, 20 bar (pH 1 – 9.5) requires a 0.12 mm i.d. capillary (e.g. p/n G1316-87318, 300 mm long), part of Capillary kit for 0.12 mm id (p/n G1316-68716)
OR G5615-60005	Bio-inert flow cell, 8 μ L, 20 bar (pH 1–12) includes Capillary Kit Flow Cells BIO (p/n G5615-68755)
G5615-68755	Capillary Kit Flow Cells BIO includes Peek Capillary i.d. 0.18 mm, 1.5 m lg and PEEK Fittings 10/PK (p/n 5063-6591)
G1321-60007	FLD Cuvette Kit, 8 μ L, 20 bar
9301-0407	Needle
9301-1446	Syringe
5067-4691	Front Panel DAD/VWD/FLD (1260/1290)
5041-8388	Leak funnel
5041-8389	Leak funnel
5041-8387	Tube clip
5062-2463	Corrugated tubing, PP, 6.5 mm id, 5 m
5062-2462	PTFE Tubing flexible i.d. 0.8 mm, o.d. 1.6 mm, 2 m, re-order 5 m (flow cell to waste)
5181-1516	CAN cable, Agilent module to module, 0.5 m
5181-1519	CAN cable, Agilent module to module, 1 m
G1369B or G1369-60002	Interface board (LAN)
5023-0203	Cross-over network cable, shielded, 3 m (for point to point connection)
5023-0202	Twisted pair network cable, shielded, 7 m (for point to point connection)
01046-60105	Agilent module to general purpose (Analog)
G1351-68701	Interface board (BCD) with external contacts and BCD outputs

Parts for wavelength calibration, see “[Standard Accessory Kit](#)” on page 186.

Cuvette Kit

p/n	Description
G1321-60007	FLD Cuvette Kit, 8 μ L, 20 bar includes:
5062-2462	PTFE Tubing flexible i.d. 0.8 mm, o.d. 1.6 mm, 2 m, re-order 5 m (flow cell to waste)
79814-22406	SST Fitting
0100-0043	SST front ferrule
0100-0044	SST back ferrule
0100-1516	Fitting male PEEK, 2/pk
9301-0407	Needle
9301-1446	Syringe

Accessory Kit

Standard Accessory Kit

Accessory kit (G1321-68755) contains some accessories and tools needed for the installation and repair/calibration of the detector.

Item	p/n	Description
1	5062-2462	PTFE Tubing flexible i.d. 0.8 mm, o.d. 1.6 mm, 2 m, re-order 5 m (flow cell to waste)
2	0100-1516	Fitting male PEEK, 2/pk
3	G1315-87311	Capillary column – detector 380 mm lg, 0.17 i.d., (includes SST ferrule front, SST ferrule back and SST fitting).
4	0100-0043	SST front ferrule
5	0100-0044	SST back ferrule
6	79814-22406	SST Fitting

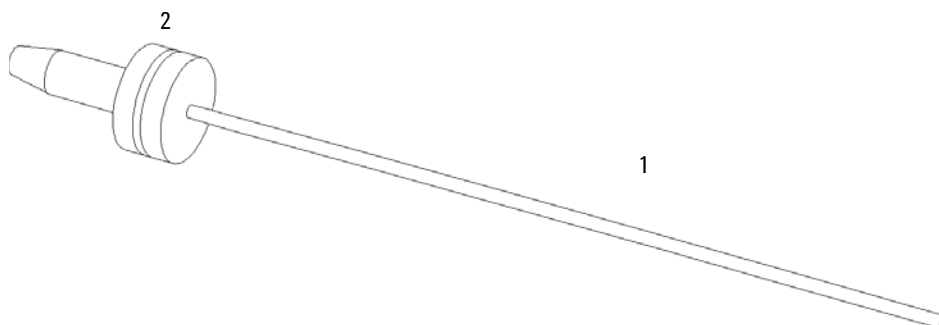

Figure 70 Waste Tubing Parts

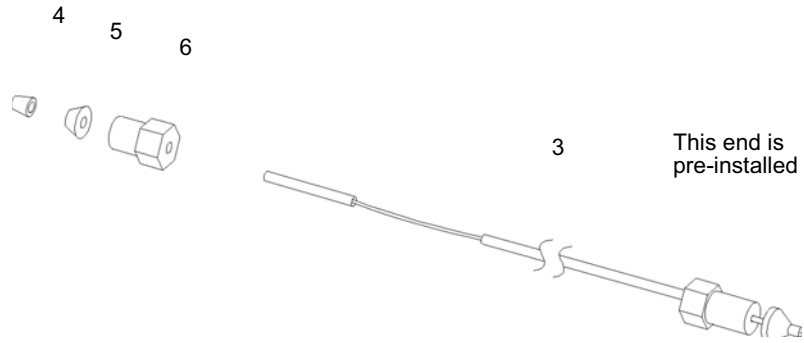

Figure 71 Inlet Capillary (Column-Detector) Parts

Capillary Kit Flow Cells BIO

Capillary Kit Flow Cells BIO includes Peek Capillary i.d. (G5615-68755) includes:

p/n	Description
0890-1763	Peek Capillary i.d. 0.18 mm, 1.5 m lg
5063-6591	PEEK Fittings 10/PK

10 Parts for Maintenance Accessory Kit



11 Identifying Cables

Cable Overview	190
Analog Cables	192
Remote Cables	194
BCD Cables	197
CAN/LAN Cables	199
External Contact Cable	200
Agilent Module to PC	201

This chapter provides information on cables used with the 1290 series of HPLC modules.



Cable Overview

NOTE

Never use cables other than the ones supplied by Agilent Technologies to ensure proper functionality and compliance with safety or EMC regulations.

Analog cables

p/n	Description
35900-60750	Agilent module to 3394/6 integrators
35900-60750	Agilent 35900A A/D converter
01046-60105	Analog cable (BNC to general purpose, spade lugs)

Remote cables

p/n	Description
03394-60600	Agilent module to 3396A Series I integrators 3396 Series II / 3395A integrator, see details in section " Remote Cables " on page 194
03396-61010	Agilent module to 3396 Series III / 3395B integrators
5061-3378	Remote Cable
01046-60201	Agilent module to general purpose

BCD cables

p/n	Description
03396-60560	Agilent module to 3396 integrators
G1351-81600	Agilent module to general purpose

CAN cables

p/n	Description
5181-1516	CAN cable, Agilent module to module, 0.5 m
5181-1519	CAN cable, Agilent module to module, 1 m

LAN cables

p/n	Description
5023-0203	Cross-over network cable, shielded, 3 m (for point to point connection)
5023-0202	Twisted pair network cable, shielded, 7 m (for point to point connection)

RS-232 cables

p/n	Description
G1530-60600	RS-232 cable, 2 m
RS232-61601	RS-232 cable, 2.5 m Instrument to PC, 9-to-9 pin (female). This cable has special pin-out, and is not compatible with connecting printers and plotters. It's also called "Null Modem Cable" with full handshaking where the wiring is made between pins 1-1, 2-3, 3-2, 4-6, 5-5, 6-4, 7-8, 8-7, 9-9.
5181-1561	RS-232 cable, 8 m

Analog Cables

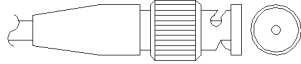

One end of these cables provides a BNC connector to be connected to Agilent modules. The other end depends on the instrument to which connection is being made.

Agilent Module to 3394/6 Integrators

p/n 35900-60750	Pin 3394/6	Pin Agilent module	Signal Name
	1		Not connected
	2	Shield	Analog -
	3	Center	Analog +

Agilent Module to BNC Connector

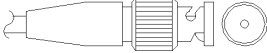
p/n 8120-1840	Pin BNC	Pin Agilent module	Signal Name
	Shield	Shield	Analog -
	Center	Center	Analog +

Agilent Module to General Purpose

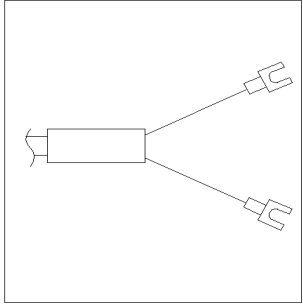
p/n 01046-60105	Pin	Pin Agilent module	Signal Name
	1		Not connected
	2	Black	Analog -
	3	Red	Analog +

Remote Cables



One end of these cables provides a Agilent Technologies APG (Analytical Products Group) remote connector to be connected to Agilent modules. The other end depends on the instrument to be connected to.

Agilent Module to 3396A Integrators

p/n 03394-60600	Pin 3396A	Pin Agilent module	Signal Name	Active (TTL)
<p>A diagram of the Agilent module connector, a vertical rectangular component with a central row of pins. Pins 1, 5, 8, and 9 are specifically labeled. Pin 1 is at the bottom left, pin 5 is at the top right, pin 8 is at the top left, and pin 9 is at the bottom right.</p>	9	1 - White	Digital ground	
	NC	2 - Brown	Prepare run	Low
	3	3 - Gray	Start	Low
	NC	4 - Blue	Shut down	Low
	NC	5 - Pink	Not connected	
	NC	6 - Yellow	Power on	High
	5,14	7 - Red	Ready	High
	1	8 - Green	Stop	Low
	NC	9 - Black	Start request	Low
	13, 15		Not connected	

Agilent Module to 3396 Series II / 3395A Integrators

Use the cable Agilent module to 3396A Series I integrators (03394-60600) and cut pin #5 on the integrator side. Otherwise the integrator prints START; not ready.

Agilent Module to 3396 Series III / 3395B Integrators

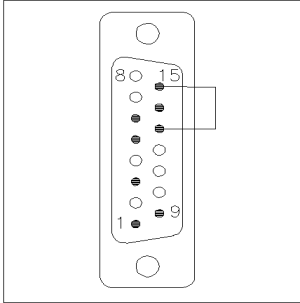
p/n 03396-61010	Pin 33XX	Pin Agilent module	Signal Name	Active (TTL)
	9	1 - White	Digital ground	
	NC	2 - Brown	Prepare run	Low
	3	3 - Gray	Start	Low
	NC	4 - Blue	Shut down	Low
	NC	5 - Pink	Not connected	
	NC	6 - Yellow	Power on	High
	14	7 - Red	Ready	High
	4	8 - Green	Stop	Low
	NC	9 - Black	Start request	Low
	13, 15		Not connected	

Agilent Module to Agilent 35900 A/D Converters

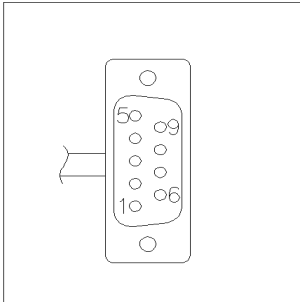
p/n 5061-3378	Pin 35900 A/D	Pin Agilent module	Signal Name	Active (TTL)
	1 - White	1 - White	Digital ground	
	2 - Brown	2 - Brown	Prepare run	Low
	3 - Gray	3 - Gray	Start	Low
	4 - Blue	4 - Blue	Shut down	Low
	5 - Pink	5 - Pink	Not connected	
	6 - Yellow	6 - Yellow	Power on	High
	7 - Red	7 - Red	Ready	High
	8 - Green	8 - Green	Stop	Low
	9 - Black	9 - Black	Start request	Low

11 Identifying Cables

Remote Cables

Agilent Module to General Purpose

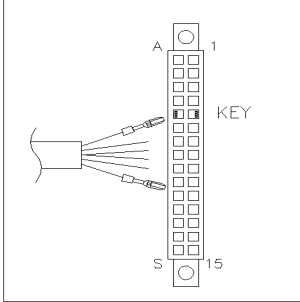
p/n 01046-60201	Wire Color	Pin Agilent module	Signal Name	Active (TTL)
	White	1	Digital ground	
	Brown	2	Prepare run	Low
	Gray	3	Start	Low
	Blue	4	Shut down	Low
	Pink	5	Not connected	
	Yellow	6	Power on	High
	Red	7	Ready	High
	Green	8	Stop	Low
	Black	9	Start request	Low

BCD Cables



One end of these cables provides a 15-pin BCD connector to be connected to the Agilent modules. The other end depends on the instrument to be connected to

Agilent Module to General Purpose

p/n G1351-81600	Wire Color	Pin Agilent module	Signal Name	BCD Digit
	Green	1	BCD 5	20
	Violet	2	BCD 7	80
	Blue	3	BCD 6	40
	Yellow	4	BCD 4	10
	Black	5	BCD 0	1
	Orange	6	BCD 3	8
	Red	7	BCD 2	4
	Brown	8	BCD 1	2
	Gray	9	Digital ground	Gray
	Gray/pink	10	BCD 11	800
	Red/blue	11	BCD 10	400
	White/green	12	BCD 9	200
	Brown/green	13	BCD 8	100
	not connected	14		
	not connected	15	+ 5 V	Low

11 Identifying Cables

BCD Cables

Agilent Module to 3396 Integrators

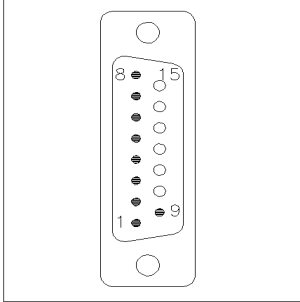
p/n 03396-60560	Pin 3396	Pin Agilent module	Signal Name	BCD Digit
	1	1	BCD 5	20
	2	2	BCD 7	80
	3	3	BCD 6	40
	4	4	BCD 4	10
	5	5	BCD0	1
	6	6	BCD 3	8
	7	7	BCD 2	4
	8	8	BCD 1	2
	9	9	Digital ground	
	NC	15	+ 5 V	Low

CAN/LAN Cables

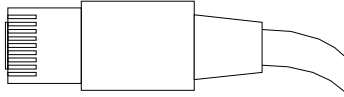

Both ends of this cable provide a modular plug to be connected to Agilent modules CAN or LAN connectors.

CAN Cables

p/n	Description
5181-1516	CAN cable, Agilent module to module, 0.5 m
5181-1519	CAN cable, Agilent module to module, 1 m

LAN Cables

p/n	Description
5023-0203	Cross-over network cable, shielded, 3 m (for point to point connection)
5023-0202	Twisted pair network cable, shielded, 7 m (for point to point connection)

External Contact Cable

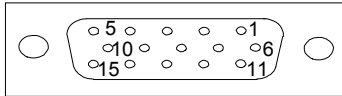

One end of this cable provides a 15-pin plug to be connected to Agilent modules interface board. The other end is for general purpose.

Agilent Module Interface Board to general purposes

p/n G1103-61611	Color	Pin Agilent module	Signal Name
	White	1	EXT 1
	Brown	2	EXT 1
	Green	3	EXT 2
	Yellow	4	EXT 2
	Grey	5	EXT 3
	Pink	6	EXT 3
	Blue	7	EXT 4
	Red	8	EXT 4
	Black	9	Not connected
	Violet	10	Not connected
	Grey/pink	11	Not connected
	Red/blue	12	Not connected
	White/green	13	Not connected
	Brown/green	14	Not connected
	White/yellow	15	Not connected

Agilent Module to PC

p/n	Description
G1530-60600	RS-232 cable, 2 m
RS232-61601	RS-232 cable, 2.5 m Instrument to PC, 9-to-9 pin (female). This cable has special pin-out, and is not compatible with connecting printers and plotters. It's also called "Null Modem Cable" with full handshaking where the wiring is made between pins 1-1, 2-3, 3-2, 4-6, 5-5, 6-4, 7-8, 8-7, 9-9.
5181-1561	RS-232 cable, 8 m

11 Identifying Cables

Agilent Module to PC