



BMW Motorrad



The Ultimate
Riding Machine

Rider's Manual (US Model)
G 650 GS

Motorcycle/Dealer Data

Motorcycle data

Model

Vehicle identification number

Color number

Initial registration

License plate

Dealer Data

Contact in Service

Ms./Mr.

Phone number

Dealer's address/phone number (company stamp)

Welcome to BMW

Congratulations on choosing a motorcycle from BMW Motorrad and welcome to the community of BMW motorcycle owners and riders. Familiarize yourself with your new motorcycle so that you can ride it safely and confidently in all highway traffic situations.

About this Rider's Manual

Please read this Rider's Manual carefully before starting to use your new BMW. It contains important information on how to operate the controls and how to get the most benefit from your BMW's advanced technical features.

In addition, it contains information on maintenance and care to help you maintain your vehicle's reliability and safety, as well as its value.

Suggestions and complaints

If you have any questions concerning your motorcycle, your authorized BMW Motorrad retailer is always happy to provide advice and assistance.

We wish you many miles of safe and enjoyable riding on your BMW

BMW Motorrad.

01 41 8 557 097



Table of Contents

1 General instructions	5	3 Displays	19	Tires	37
Overview	6	Multifunction display	20	Headlight	37
Abbreviations and symbols	6	Warning and indicator lamps	21	Seat	38
Equipment	6	Distance covered since the fuel reached the reserve level	22	Storage compartment	40
Technical data	7	Warning lamps	22	5 Riding	41
Notice concerning current sta- tus	7	4 Operation.....	27	Safety instructions	42
2 Overviews	9	Steering and ignition lock	28	Checklist	44
General view, left side	11	Clock	29	Starting.....	44
General view, right side	13	Display	30	Breaking in	47
Underneath seat	14	Lights	30	Speed	48
Instrument cluster	15	Turn indicator	31	Off-road riding	48
Multifunction switch, left	16	Hazard warning flashers	31	Brakes	49
Multifunction switch, right	17	Emergency-off switch (kill switch)	32	Parking your motorcycle	50
Auxiliary switch	18	Heated handlebar grips	32	Refueling	50
		BMW Motorrad ABS	33	Fuel specifications	51
		Clutch	34	Securing motorcycle for transport	52
		Mirrors	35	6 Technology in detail	55
		Spring preload	35	Brake system with BMW Motorrad ABS	56
		Damping	36		

7 Accessories	59	9 Care	101	Dimensions	117
General instructions	60	Care products	102	Weights	118
Onboard sockets	60	Washing your motorcycle.....	102	Performance data	118
Case	61	Cleaning sensitive motorcycle parts.....	102	11 Service	119
Topcase.....	64	Paint care	103	Reporting safety defects	120
8 Maintenance	67	Storing the motorcycle	104	BMW Motorrad Service ...	121
General instructions	68	Protective wax coating	104	BMW Motorrad Mobility Services.....	121
Onboard toolkit.....	68	Returning motorcycle to use	104	Maintenance procedures.....	121
Engine oil	68	10 Technical data	105	Confirmation of maintenance work.....	123
Brake system	70	Troubleshooting chart.....	106	Confirmation of service....	128
Coolant.....	74	Threaded fasteners	107	12 Index	130
Clutch	75	Engine	109		
Chain.....	75	Fuel	110		
Wheels	77	Engine oil	110		
BMW Motorrad front wheel stand	82	Clutch	111		
Fuses	84	Transmission.....	111		
Bulbs.....	85	Rear-wheel drive	112		
Air filter.....	90	Suspension	112		
Jump-starting	92	Brakes	113		
Battery	93	Wheels and tires	113		
Fairings and panels	96	Electrical system	114		
		Frame	116		

General instructions

Overview	6
Abbreviations and symbols	6
Equipment	6
Technical data	7
Notice concerning current status	7

Overview

Chapter 2 of this Rider's Manual will provide you with an initial overview of your motorcycle. All maintenance and repair work carried out on your motorcycle will be documented in chapter 11. Documentation confirming performance of scheduled maintenance is a precondition for generous handling of out-of-warranty claims and goodwill warranty treatment.

When the time comes to sell your BMW, please remember to hand over this Rider's Manual; it is an important part of the motorcycle.

Abbreviations and symbols



Indicates warnings that are imperative to observe for your own safety and the safety

of others, and to protect your product against damage.



Special information on operating and inspecting your motorcycle as well as maintenance and adjustment procedures.



Indicates the end of an item of information.



Instruction.



Result of an activity.



Reference to a page with more detailed information.



Indicates the end of accessory or equipment-dependent information.



Tightening torque.



Technical data.

OE

Optional extra. BMW Motorrad optional extras are already completely installed during motorcycle production.

OA

Optional accessory. BMW Motorrad optional accessories can be purchased and installed at your authorized BMW Motorrad retailer.

ABS

Anti-Lock Brake System.

Equipment

When you ordered your BMW motorcycle, you chose various items of custom equipment. This Rider's Manual describes optional equipment (OE) offered by BMW and selected optional accessories (OA). This explains why the man-

ual may also contain descriptions of equipment which you have not ordered. Please note, too, that your motorcycle might not be exactly as illustrated in this manual on account of country-specific differences.

If your BMW is equipped with options or accessories not described in this Rider's Manual, then this equipment is described in separate operating instructions.

Technical data

All dimensions, weights and performance data contained this Rider's Manual refer to the German DIN standards and comply with their tolerance specifications. Versions for individual countries may differ.

Notice concerning current status

The high safety and quality standards of BMW motorcycles are maintained by consistent, ongoing development efforts embracing their design, equipment and accessories. For this reason, some aspects of your motorcycle may vary from the descriptions in this Rider's Manual. In addition, BMW Motorrad cannot guarantee the total absence of errors. We hope you will appreciate that no claims can be recognized based on the data, illustrations or descriptions in this manual.

Overviews

General view, left side.....	11
General view, right side	13
Underneath seat	14
Instrument cluster	15
Multifunction switch, left	16
Multifunction switch, right.....	17
Auxiliary switch	18





General view, right side

- 1 Fuel filler opening (►► 50)
- 2 Brake-fluid reservoir, front (►► 72)
- 3 Type plate (on right frame tube)
Vehicle Identification Number (on right steering-head bearing)
- 4 Air filter (under fairing side panel) (►► 90)
- 5 Adjusting spring preload (►► 35)
- 6 Adjusting damping (►► 36)
- 7 Brake-fluid reservoir, rear (►► 73)
- 8 Chain tension label (on rear wheel swinging arm)

Underneath seat

- 1 Fuse box (→ 84)
- 2 Onboard toolkit (→ 68)
- 3 Payload table
Storage tray for Rider's
Manual

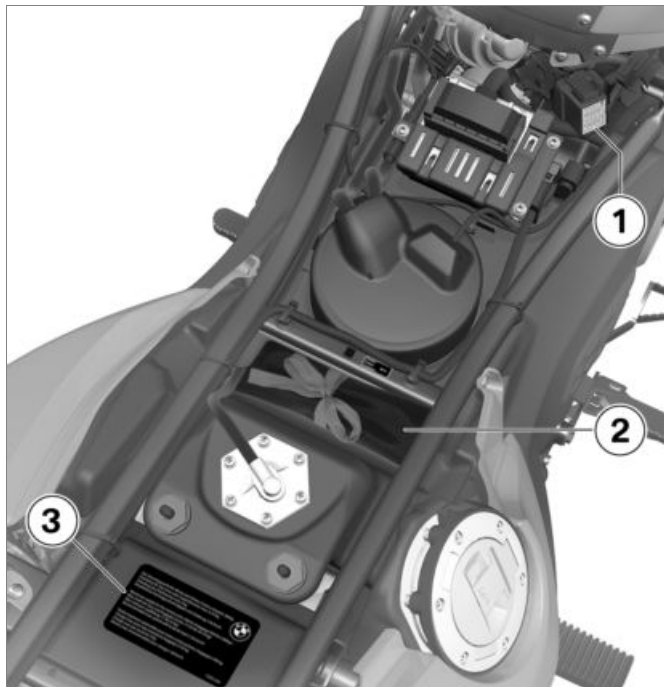

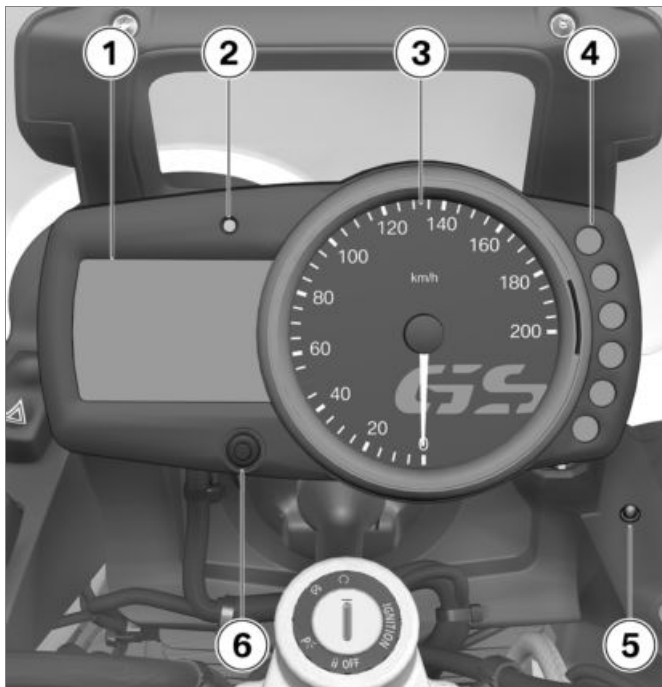

Instrument cluster

- 1 Multifunction display (➡ 20)
- 2 Engine speed warning (➡ 48)
- 3 Speedometer
- 4 Warning and indicator lamps (➡ 21)
- 5 Anti-theft alarm system status LED (refer to operating instructions for alarm system)
- 6 Operating clock (➡ 29)
Operating odometer (➡ 30)

Multifunction switch, left

- 1 Headlight flasher
- 2 ABS operation (→ 33)
- 3 Turn indicator switch (→ 31)
- 4 Horn
- 5 High-beam headlight (→ 31)

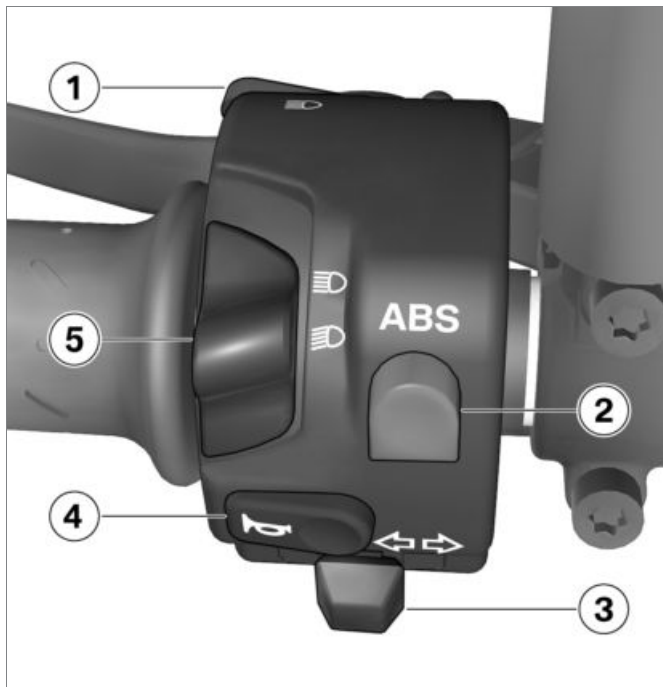

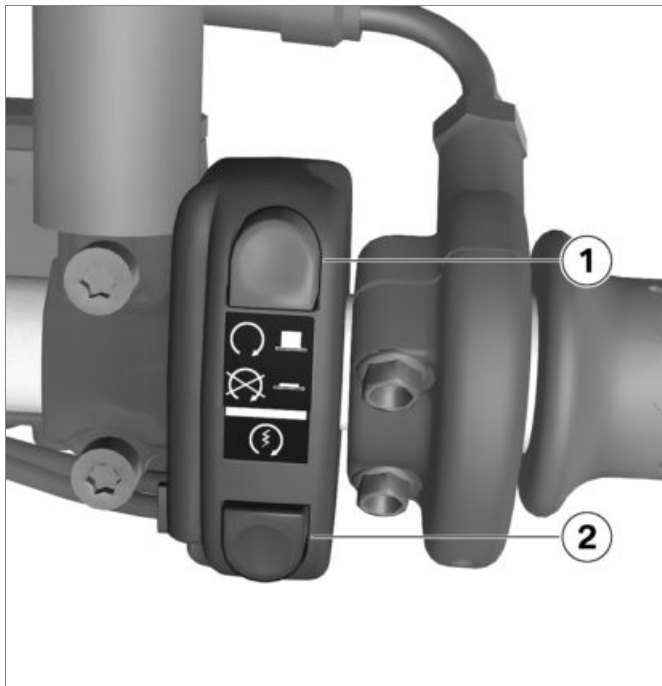

Multifunction switch, right

- 1 Emergency-off switch (kill switch) (→ 32)
- 2 Starter button (→ 44)

Auxiliary switch

- 1 Hazard warning flashers
([►► 31](#))
- 2 – with heated handlebar grips^{OE}
Heated handlebar grips
([►► 32](#))

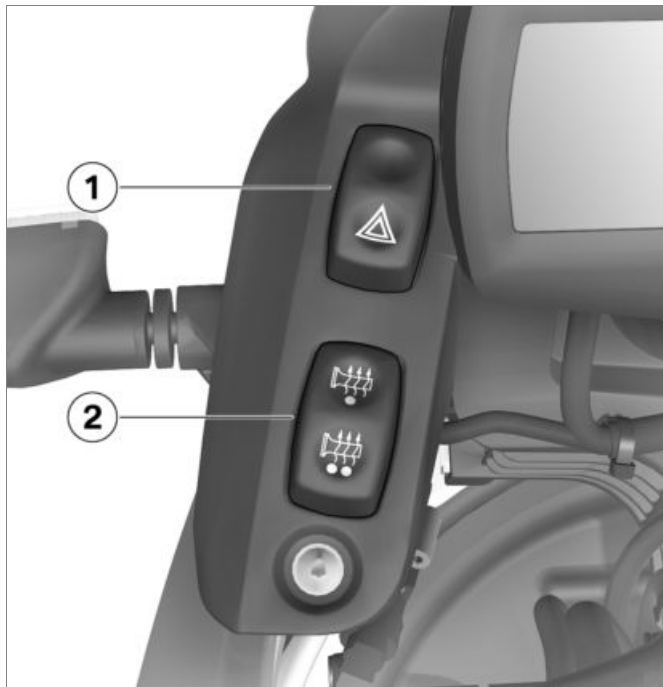

Displays

Multifunction display	20
Warning and indicator lamps	21
Distance covered since the fuel reached the reserve level	22
Warning lamps	22

Multifunction display

- 1 Symbol for mileage covered since fuel reached reserve level (☰➔ 22)
- 2 Symbol for tripmeter (Trip 1 or Trip 2) (☰➔ 30)
- 3 Display sector for trip odometer and mileage covered since fuel reached reserve level
- 4 RPM limit
- 5 Tachometer
- 6 Clock
- 7 Symbol for setting clock (☰➔ 29)
- 8 Total distance

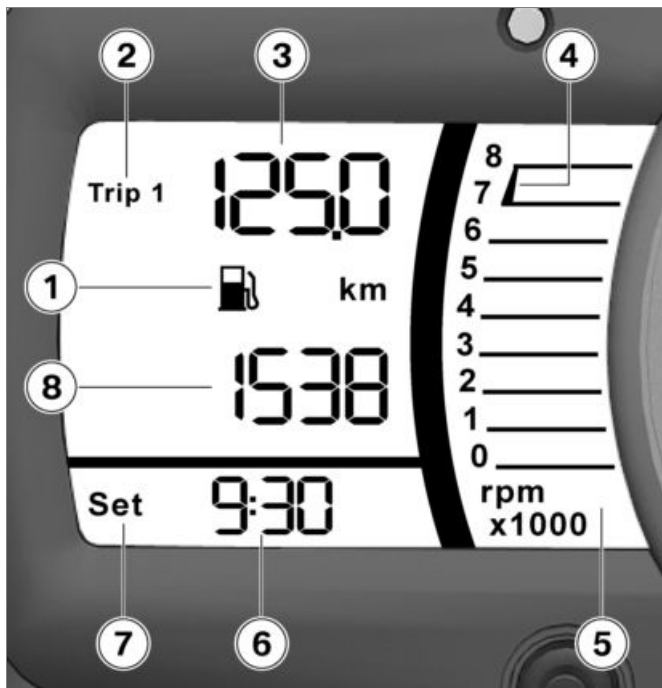



Warning and indicator lamps

- 1 Turn signal indicator lamp
- 2 Fuel-reserve warning lamp (►► 24)
- 3 Neutral indicator lamp
- 4 ABS warning lamp (►► 24)
- 5 Coolant warning lamp (►► 24)
- 6 Headlight high beam indicator lamp

Distance covered since the fuel reached the reserve level



Once the fuel level falls to the reserve sector the distance covered since operation in the reserve range started appears in the display. This odometer is reset and no longer appears as soon as the tank is refueled to a level higher than the reserve level.

The trip odometer and the clock setting can still be accessed.

Warning lamps

Display

Warnings are displayed with the corresponding warning lamp. The following page contains a list of potential warnings.

Overview of warning indicators

Warning and indicator lamps	Warning symbols in the display panel	Meaning
-----------------------------	--------------------------------------	---------



Lights up

Fuel down to reserve (▬▶ 24)



Lights up

Coolant temperature too high (▬▶ 24)



Flashes

ABS self-diagnosis not completed (▬▶ 24)



Lights up

ABS deactivated (▬▶ 25)



Lights up

ABS error (▬▶ 25)

Fuel down to reserve



Fuel-reserve warning light lights up.



A fuel shortage can cause irregular engine operation or engine shut-off (accident hazard) and the catalytic converter can be damaged.

Do not drive to the extent that the fuel tank is completely empty. ◀

Possible cause:

At the most, the fuel tank still contains the reserve fuel quantity.



Reserve fuel quantity

Approx. 1.1 gal (Approx. 4 l)

- Refueling (▶▶▶ 50).

Coolant temperature too high



Coolant-temperature warning light lights up.



Driving with an overheated engine can result in engine damage.

Be sure to observe the measures listed below. ◀

Possible cause:

Coolant level too low.

- Checking coolant level (▶▶▶ 74).
- If coolant level is too low:
- Topping up coolant (▶▶▶ 74).

Possible cause:

Radiator fan defective.

If the radiator fan fails to run with the coolant-temperature warning light switched on:

- Have the malfunction corrected as soon as possible at an authorized service facility,

preferably an authorized BMW Motorrad Dealer.

Possible cause:

Cooling is insufficient.

- If possible, continue driving in the part-load range to cool down the engine.
- In traffic jams, switch off the engine, but keep the ignition switched on so that the radiator fan continues to operate.
- Should the coolant temperature frequently be too high, have the fault rectified as quickly as possible by an authorized workshop, preferably an authorized BMW Motorrad retailer.

ABS self-diagnosis not completed



ABS warning light flashes.

Possible cause:

The ABS function is not available, because the self-diagnosis has not been completed. To check the wheel sensors, the motorcycle must be driven a few yards.

- Ride off slowly. It must be noted that the ABS function is not available until the self-diagnosis has been completed.

ABS deactivated



ABS warning light lights up.

Possible cause:

The ABS system has been deactivated by the driver.

- Switch on the ABS function.

ABS error



ABS warning light lights up.

Possible cause:

The ABS control unit has detected an error. The ABS function is not available.

- It remains possible to continue riding. It must be noted that the ABS function is not available. Observe additional information on conditions that can lead to an ABS error (► 57).
- Have the malfunction corrected as soon as possible at an authorized service facility, preferably an authorized BMW Motorrad Dealer.

Operation

Steering and ignition lock	28	Headlight	37
Clock	29	Seat	38
Display.....	30	Storage compartment	40
Lights.....	30		
Turn indicator.....	31		
Hazard warning flashers.....	31		
Emergency-off switch (kill switch).....	32		
Heated handlebar grips	32		
BMW Motorrad ABS.....	33		
Clutch	34		
Mirrors.....	35		
Spring preload	35		
Damping.....	36		
Tires	37		

Steering and ignition lock

Keys

Two main keys and one emergency key are provided with the vehicle. The emergency key features a light, compact design, allowing it to be carried in a wallet, etc. This key is intended for use when no main key is immediately available, and is not suitable for continuous use.

The steering and ignition lock, tank lock and seat lock are operated with the same key.

- with Vario case^{OA}
- with Topcase^{OA}

The cases and the topcase can also be ordered with locks for the same key on request. Please contact an authorized workshop for this purpose, preferably an authorized BMW Motorrad retailer.

Switch on ignition



- Turn key to position **1**.
 - » Parking lights, low-beam headlight and all function circuits are switched on.
 - » Engine can be started.
 - » Pre-Ride-Check in progress. (▮▮▮▶ 46)
 - » ABS self-diagnosis in progress. (▮▮▮▶ 46)

Switch off ignition



- Turn key to position **2**.
 - » Light is switched off.
 - » Handlebars are not locked.
 - » Key can now be removed.

Locking steering lock with parking light



If the motorcycle is on the side stand, the surface of the ground will determine whether it is better to turn the handlebars to the left or right. However, the motorcycle is more stable on a level surface with the handlebars turned to the left than

with the handlebars turned to the right.

On level ground, always turn the handlebars to the left to set the steering lock.◀

- Turn handlebars to full left or right lock position.



- Turn key to position **3** while moving handlebars slightly.
 - » Parking light switched on.
 - » Handlebars locked.
 - » Key can be removed.

Locking steering lock without parking light

- Locking steering lock with parking light (▶▶ 28).



- Turn key further to position **4**.
 - » Parking lights are now switched off.
 - » Handlebars are locked.
 - » Key can now be removed.

Clock

Setting clock

 Attempting to set the clock while riding the motorcycle can lead to accidents. Adjust the clock only when the motorcycle is stationary.◀

- Switch on ignition.



- Press button **1** repeatedly until SET **2** is displayed.
- Press and hold button until hours display flashes.
- Press button repeatedly until desired hours are shown.

- Press and hold button until minutes display flashes.
 - Press button repeatedly until desired minutes are shown.
 - Press and hold button until minutes no longer flash.
- » Setting is completed.

Display

Selecting readings

- Switch on ignition.



- Press button **1** to select value in display.

The following values can be displayed:

- Tripmeter 1 (Trip 1)
- Tripmeter 2 (Trip 2)



Kilometers driven after reaching the reserve quantity

- Clock setting (SET)

Resetting trip odometer

- Switch on ignition.
- Select desired trip odometer.



- Press and hold button **1** until trip odometer has been reset.

Lights

Parking lights

The parking lights switch on automatically when the ignition is switched on.

▶ The parking lights are a strain on the battery. Do not leave the ignition switched on longer than absolutely necessary. ◀

Headlight low beam

The low-beam headlight switches on automatically when the ignition is switched on.

▶ The low-beam headlight is a strain on the battery. Do not leave the ignition switched on longer than absolutely necessary. ◀

High-beam headlight



- Slide the switch **1** upward to switch on the high beam.
- Slide the switch **1** downward to deactivate the high beam.

Headlight flasher



- Press button **1**.
» The high-beam headlight is switched on for as long as the button is pressed.

Turn indicator

Operating turn indicator

- Switch on ignition.



- Press button **1** toward left to switch on left-hand turn indicator.
- Press button **1** toward right to switch on right-hand turn indicator.
- Press button **1** into center position to switch off turn indicators.

Hazard warning flashers

Operating hazard warning flashers

- Switch on ignition.

▶ The hazard warning flashers place a strain on the battery. Do not use the hazard warning flashers for longer than absolutely necessary.◀



- Press the bottom of the hazard warning flasher switch **1** to activate the hazard warning flasher.
- Ignition can be switched off.
- Press the top of the hazard warning flasher switch **1** to deactivate the hazard warning flasher.

Emergency-off switch (kill switch)



- 1** Emergency-off switch (kill switch)

! Operating the emergency ON/OFF switch when riding can cause the rear wheel to lock and thus cause a fall. Do not operate the emergency ON/OFF switch when riding.◀

The engine can be switched off easily and quickly using the emergency kill switch.



- Switch not activated: standard operating position
- Switch activated: engine switched off

▶ The engine can only be started in the operating position.◀

Heated handlebar grips

- with heated handlebar grips^{OE}



1 Heated handlebar-grip switch

The handlebar grips can be heated at two different levels. The second level is used for fast heating of the grips; the switch should then be switched back to the first level.

 The grip heating place a strain on the battery. Only switch on the grip heating when the engine is running.◀



 Operate switch at top: 50 % heating capacity.

- Switch in center position: heating function off.

 Operate switch at bottom: 100 % heating capacity.

BMW Motorrad ABS

Deactivating ABS function

- Stop motorcycle or switch on ignition with motorcycle stationary.



- Press and hold button **1**, continuing until ABS warning lamp's display status changes.

 ABS warning light begins to light up.

- Release button **1** within two seconds.

 ABS warning light continues to light up.

- » ABS function is deactivated.

Switching on ABS function



- Press and hold button **1**, continuing until ABS warning lamp's display status changes.

 ABS warning light goes out; if self-diagnosis has not been completed, it begins to flash.

- Release button **1** within two seconds.

 ABS warning light remains off or continues to flash.

» ABS function is now activated.

- As an alternative, the ignition can also be switched off and then on again.

 If the ABS warning light lights up after switching the ignition off and on and then continued driving over 4 mph (5 km/h), an ABS error has occurred.◀

Clutch

Adjusting clutch lever

 Adjusting the clutch lever while driving can lead to accidents.

Only adjust the clutch lever when the motorcycle is stationary.◀

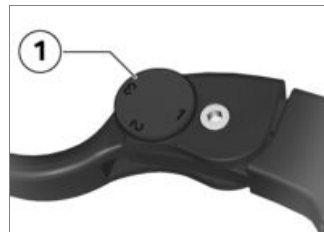

- Turn adjusting screw **1** into desired position.

 The adjusting screw can be turned more easily if you press the clutch lever forward when doing so.◀

» Adjustment options:

- from Position 1: smallest distance between handlebar grip and clutch lever
- to Position 3: largest distance between handlebar grip and clutch lever

Mirrors

Adjusting mirrors



Adjusting the mirror while driving can result in accidents.

Only adjust the mirrors with the motorcycle stopped. ◀

- Move mirror into desired position by twisting.

Adjusting mirror arm

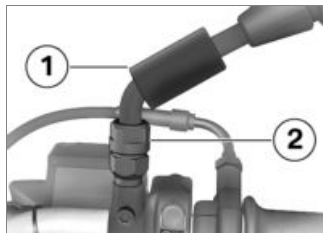

- Slide protective cap **1** up over screw connection on mirror arm.
- Loosen the nut **2**.
- Turn mirror arm into desired position.
- Tighten the nut to the specified tightening torque, while holding the mirror arm to ensure that it does not move out of position.



Locknut (mirror) on clamping piece

15 lb/ft (20 Nm)

- Slide protective cap over threaded fastener.

Spring preload Setting

It is essential to set the spring preload of the rear suspension to suit the load carried by the motorcycle. Increase spring preload when the motorcycle is heavily loaded and reduce spring preload accordingly when the motorcycle is lightly loaded.

Adjusting spring preload at rear wheel

- Park the motorcycle, ensuring that the support surface is firm and level.



! Your motorcycle's handling will suffer if you do not match the spring-preload and damping-characteristic settings. Adjust damping characteristic to changed spring preload.◀

! Adjusting the spring preload while the motorcycle is being ridden can lead to accidents. Adjust the spring preload only when the motorcycle is stationary.◀

- To increase the spring preload, turn the adjustment wheel **1** in the direction of the arrow **HARD**.

- To decrease the spring load, turn the adjustment wheel **1** in the direction of the arrow **LOW**.



Basic setting of spring preload, rear

Turn adjustment wheel completely to left, then back 15 clicks (Full tank of gas, with rider 187 lbs (85 kg))

Damping Setting

The damping must be adjusted to the road conditions and the spring preload.

- A rough road surface requires softer damping than a smooth road surface.
- An increase in spring preload requires firmer damping, a reduction in spring preload requires softer damping.

Adjusting damping on rear wheel

- Park motorcycle, ensuring that support surface is firm and level.



- Adjust damping with toolkit using adjusting screw **1**.



- To increase damping, turn adjusting screw **1** in arrow direction H.
- To decrease damping, turn adjusting screw **1** in arrow direction S.



Basic setting of rear wheel rear-wheel damping

Turn lower adjusting screw as far as possible clockwise, then turn back 0.75 turns (Full tank of gas, with rider 187 lbs (85 kg))

Tires

Checking tire pressure

 Incorrect tire inflation pressure results in poorer handling characteristics of the motorcycle and reduces the life of the tires.

Ensure proper tire inflation pressure. ◀

 At high road speeds, vertically installed tire valves have a tendency to open on their own.

Use valve caps with rubber seals and screw them on firmly to prevent sudden tire deflation. ◀

- Make sure ground is level and firm and park motorcycle.
- Check tire pressures against data below.



Tire pressure, front

31.9 psi (2.2 bar) (With tire cold)



Tire pressure, rear

36.3 psi (2.5 bar) (Single rider, with cold tire)

42.1 psi (2.9 bar) (With passenger and payload, with cold tire)

If tire pressure is too low:

- Correct tire pressure.

Headlight

Adjusting headlight for RHD/LHD traffic

This motorcycle's headlight features a symmetrical low beam. No special adjustments or procedures are required prior to operating the motorcycle in a coun-

try where traffic travels on the side of the road opposite to that of your home country (left-hand drive to right-hand drive or vice versa).

Headlight range and spring preload

The headlight range generally remains constant due to the adjustment of the spring preload to the loading state.

Spring preload adjustment may only be insufficient when the motorcycle is very heavily loaded. In this case, the headlight range must be adjusted to the weight.

▶ If there are questions whether the headlight range is correct, consult a specialized workshop, preferably an authorized BMW Motorrad retailer. ◀

Headlight range adjustment



- When the spring pretension adjustment is no longer able to maintain the correct beam height to avoid blinding oncoming traffic owing to high vehicle loads:
- Loosen screws **1** on left and right.
- Adjust headlight by tilting slightly.
- Tighten screws **1** on left and right.

Seat Removing seat

- Park motorcycle, ensuring that support surface is firm and level.

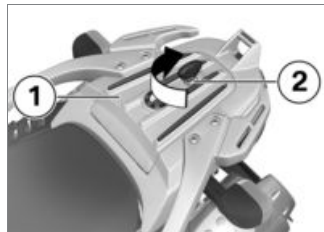

- Unlock storage compartment by turning ignition key **1** clockwise.
- Remove storage compartment lid **2**.



- Pull release lever **3** upward while assisting by pressing down seat at rear.
- Raise seat at rear and let go of release lever.
- Take off seat and place on a clean surface with upholstered side facing downward.

Installing seat

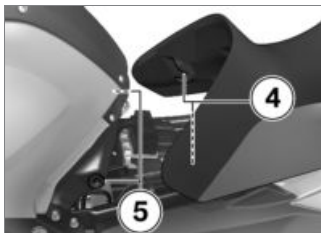

- Mount seat mounts **4** in holders **5** on left and right.
- Position seat and slide it forward all the way to travel stop.
- Firmly press down on seat at rear.
 - » The seat's detent mechanism will be heard to engage.

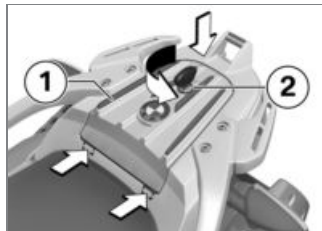

- Insert lugs **arrows** of storage compartment lid **1** in fixing points.
- Press storage compartment lid **1** downward at rear and lock by turning ignition key **2** counterclockwise.

Storage compartment Removing storage compartment lid

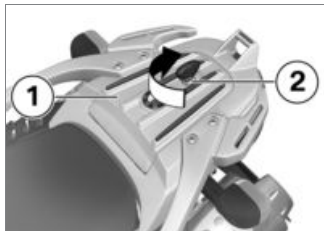

- Unlock storage compartment lid **2** by turning ignition key **1** clockwise and remove key.

Installing storage compartment lid

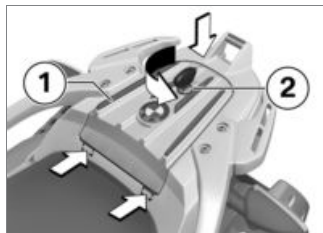

- Insert lugs **arrows** of storage compartment lid **1** in fixing points.
- Press storage compartment lid **1** downward at rear and lock by turning ignition key **2** counterclockwise.

Riding

Safety instructions	42
Checklist.....	44
Starting	44
Breaking in.....	47
Speed	48
Off-road riding	48
Brakes	49
Parking your motorcycle	50
Refueling	50
Fuel specifications	51
Securing motorcycle for trans- port	52

Safety instructions

Rider's Equipment

Do not ride without the correct clothing. Always wear:

- Helmet
- Rider's suit
- Gloves
- Boots

This applies even to short journeys, and to every season of the year. Your authorized BMW Motorrad Dealer will be happy to advise you and has the correct clothing for every purpose.

Reduced clearance in inclined position

- with lowering^{OE}

Motorcycles with lowered running gear have a reduced clearance in inclined position and to the ground compared to motorcycles

with standard running gear (see the chapter "Technical Data").



Danger of accident due to the motorcycle contacting the ground unexpectedly early. Observe the reduced ground clearance of lowered motorcycles in all positions.◀

Test the clearance of your motorcycle at an angle in safe situations. Remember to take the limited ground clearance of your motorcycle into account when driving over curbs and similar obstacles.

Lowering the motorcycle reduces the spring travel. A possible reduction in the accustomed driving comfort may result. Especially when riding with a passenger, the spring preload should be adjusted accordingly.

Loading



Overloading and imbalanced loads can adversely affect the motorcycle's handling. Do not exceed the gross weight limit and observe the loading information.◀

- Adjust spring preload, suspension damping rate settings and tire inflation pressures for the current gross vehicle weight.
- with Vario case^{OA}
- Ensure that case volumes on left and right are equal.
- Make sure that weight is uniformly distributed between right and left.
- Pack heavy luggage and cargo as low and as close to the center of the motorcycle as possible.
- Observe maximum payload and top speed as indicated on label in case.<

- with Topcase^{OA}
 - Observe maximum payload and top speed as indicated on label in Topcase.◀
- with tank rucksack^{OA}
 - Observe maximum payload of tank rucksack and corresponding top speed.

	Payload of tank rucksack
≤11 lbs (≤5 kg)	

	Speed limit for driving with tank rucksack
≤81 mph (≤130 km/h)◀	

Speed

If you ride at high speed, always bear in mind that various boundary conditions can adversely affect the handling of your motorcycle:

- Settings of spring-strut and shock absorber system
- Imbalanced load
- Loose clothing
- Insufficient tire pressure
- Poor tire tread
- Etc.

Risk of poisoning

Exhaust fumes contain carbon monoxide, which is colorless and odorless but highly toxic.

 Inhaling exhaust fumes therefore represents a health hazard and can even cause loss of consciousness with fatal consequences. Do not inhale exhaust fumes. Do not run the engine in closed rooms.◀

Danger of burns

 Engine and exhaust system become very hot when the vehicle is in use. There is a risk of burn injuries by contact with hot surfaces.

After parking the motorcycle, make sure that nobody comes into contact with the engine and exhaust system.◀

Catalytic converter

If misfiring causes unburned fuel to enter the catalytic converter, there is a danger of overheating and damage.

For this reason, observe the following points:

- Do not run the fuel tank dry
- Do not run the engine with the spark-plug cap removed
- Stop the engine immediately if it misfires
- Use unleaded fuel only

– Comply with all specified maintenance intervals.



Unburned fuel will destroy the catalytic converter.

Note the points listed for protection of the catalytic converter. ◀

Danger of overheating



Cooling would be inadequate if the engine were allowed to idle for a lengthy period with the motorcycle at a standstill: overheating would result. In extreme cases, the motorcycle could catch fire.

Do not allow the engine to idle unnecessarily. After starting, ride off immediately. ◀

Modifications



Modifications of the motorcycle (e.g. engine management system, throttle valves, clutch) can cause damage to the affected components and fail-

ure of safety-related functions. Damage caused in this way is not covered by the warranty. Do not make any modifications. ◀

Checklist

Use the following checklist to check important functions, settings and wear limits before you ride off:

- Brakes
- Front and rear brake fluid levels
- Clutch
- Shock absorber setting and spring preload
- Tread depth and tire pressure
- Firm seating of cases and luggage

At regular intervals:

- Engine oil level (every time you refuel)
- Brake pad wear (during every third stop for refueling)
- Tension and lubrication of drive chain

Starting

Starting the engine



- Emergency-off switch (kill switch) **1** in position for normal operation.
- with anti-theft alarm^{OE}
- Deactivate the anti-theft alarm system as required. ◀



Transmission lubrication is only ensured when the engine is running. Insufficient lubrication can lead to transmission damage.

Do not allow the motorcycle to

roll for longer periods or push it over longer distances with the engine switched off. ◀

- Switch on ignition.
 - » Pre-Ride Check in progress. (▣► 46)
 - » ABS self-diagnosis in progress. (▣► 46)
- with anti-theft alarm^{OE}

When the alarm system's status LED is illuminated this indicates that the vehicle immobilizer is active. It is not possible to start the engine.

- Using the remote control to switch off the vehicle immobilizer. ◀
- Wait until coolant-temperature warning lamp no longer flashes.

▶ After the ignition is switched on, the idling positioner is positioned. If positioning takes longer than the pre-ride check, this is signaled by the coolant-temperature

warning light flashing. You should wait for this procedure to be completed to avoid problems during driving. ◀

- Engage neutral, or pull back clutch lever if a gear is engaged.

▶ You cannot start the motorcycle with the side stand extended and a gear engaged. The engine will switch itself off if it is started with the transmission in neutral and then a gear is engaged before retracting the side stand. ◀

- For cold starts and at low ambient temperatures: pull the lever to disengage the clutch and twist the throttle grip slightly.



- Press starter button **2**.

▶ If the engine fails to start although the starter turns, insufficient battery voltage may be the reason. Recharge the battery before you start the engine, or use jump leads and a donor battery to start. ◀

- » Engine starts.
- » Consult the troubleshooting chart if the engine refuses to start. (▣► 106)

Pre-Ride Check

After the ignition is switched on, the instrument cluster conducts a test of the warning and indicator lights and the display, the so-called "Pre-Ride-Check".

Phase 1

The warning and indicator lights and all segments of the multifunction display are switched on.

Phase 2

The pointer of the speedometer is run up to the end stop and back again.

Phase 3

All lamps and segments are switched off.

The instrument cluster switches into normal operation.

If the pointer has not been moved, if one of the warning and indicator lights was not switched on or no all segments of the multifunction display were visible:



If it was not possible to switch on the warning lights, possible malfunctions cannot be indicated.

Watch all warning and indicator lights on the display. ◀

- Have the malfunction corrected as soon as possible at an authorized service facility, preferably an authorized BMW Motorrad Dealer.

ABS self-diagnosis

The readiness for operation of the BMW Motorrad ABS is checked by the self-diagnosis. The self-diagnosis routine runs automatically when you switch on the ignition. To check the wheel

sensors, the motorcycle must be driven a few yards.

Phase 1

- » Check on system components monitored by diagnostic system while motorcycle is parked.



ABS warning light flashes.

Phase 2

- » Checking wheel sensors while starting off.



ABS warning light flashes.

ABS self-diagnosis completed

- » The ABS warning light goes out.

If an ABS error is indicated following completion of the ABS self-diagnosis routine:

- It remains possible to continue riding. It must be noted that

the ABS function is not available.

- Have the malfunction corrected as soon as possible at an authorized service facility, preferably an authorized BMW Motorrad Dealer.

Breaking in

Engine

- Until the first maintenance work is carried out, vary the throttle opening and engine-speed range frequently; avoid driving for long periods at a constant speed.
- Try to do most of your riding during this initial period on twisting, fairly hilly roads, avoiding highways if possible.
- Observe the engine run-in speeds.



Engine run-in speed

max 5,000 min⁻¹ (for the first 621 miles (1,000 km))

- Have first maintenance work conducted after 300 - 750 mls (500 - 1,200 km).

Brake pads

New brake pads must be run in before they achieve their optimum friction force. This initial reduction in braking efficiency can be compensated for by exerting greater pressure on the brake levers.



New brake pads can extend stopping distance by a significant margin. Brake early.◀

Tires

New tires have a smooth surface. This must be roughened by riding in a restrained manner at various heel angles until the tires are run in. This running in procedure is essential if the tires are to achieve maximum grip.



New tires do not provide full tire traction. Accident hazards exist in particular on wet roads and at extreme angles. Always think well ahead and avoid extreme angles.◀

Speed

Engine speed warning



The engine rpm warning **1** alerts the rider that the red overspeed range **2** has been reached. The signal is maintained until the transmission is upshifted or the engine speed is reduced.

Off-road riding

After driving offroad

BMW Motorrad recommends that the following be observed after driving offroad:

Tire inflation pressure

 A tire inflation pressure reduced for offroad driving leads to poorer handling of the motorcycle on paved roads and can result in accidents. Ensure proper tire inflation pressure. ◀

Brakes

 When the motorcycle is ridden on loose surfaces or muddy roads, the brakes may fail to take effect immediately because of dirt or moisture on the disks or brake pads. Brake early until the brakes are braked clean. ◀

 Driving on unpaved or dirty roads leads to increased brake pad wear. Check the brake pad thickness more often and replace the brake pads sooner. ◀

Spring preload and damping

 Spring preload and damping values that have been changed for offroad use reduce handling characteristics on paved surfaces. Before returning to on-road use, reset correct spring preload and correct damping. ◀

Rims

BMW Motorrad recommends checking the rims for possible damage after riding offroad.

Air cleaner insert

 Engine damage due to soiled air filter insert. When driving in dusty terrain, check air filter insert for soiling at short intervals and clean or replace if necessary. ◀
Use under very dusty conditions (deserts, savannas, etc.) requires the use air cleaner inserts spe-

cially developed for these kinds of applications.

Brakes

How do you achieve the shortest stopping distances?

The dynamic load distribution between the front and rear wheel changes during braking. The heavier you brake, the greater the weight transfer to the front wheel. Increases in the load on an individual wheel are accompanied by a rise in the effective braking force that the wheel can provide.

To achieve the shortest braking distance, actuate the front and rear brake. The front brake must be actuated rapidly and with increasing force to optimally utilize the dynamic load increase on the front wheel. The clutch should also be disengaged at

the same time. With the "forced braking" often practiced in which the brake pressure is generated as quickly as possible and with great force, the dynamic load distribution cannot follow the increased deceleration and the braking force cannot be completely transferred to the road surface. To prevent the front wheel from locking, the ABS system must intervene and reduce the brake pressure; the braking distance increases.

Descending mountain passes



There is a danger of the brakes fading if you use only the rear brakes when descending mountain passes. Under extreme conditions, the brakes could overheat and suffer severe damage. Use both front and rear brakes,

and make use of the engine's braking effect as well. ◀

Wet, soiled brakes

Moisture and dirt on the brake disks and the brake pads result in a decrease in the braking action. Delayed or poorer braking action must be expected in the following situations:

- When driving in the rain and through puddles.
- After washing the motorcycle.
- When driving on roads spread with salt.
- After working on the brakes due to oil or grease residues.
- When driving on soiled roads or offroad.



Poor braking action due to moisture and dirt. Brake until brakes are dry or clean; clean if necessary. Brake early until the full braking action is available again. ◀

Parking your motorcycle

Side stand

- Switch off engine.

 If the ground is soft or uneven, there is no guarantee that the motorcycle will rest firmly on the stand.

Always check that the ground under the stand is level and firm.◀

- Fold out side stand and park motorcycle.

 The side stand is designed to support only the weight of the motorcycle.

Do not lean or sit on the motorcycle with the side stand extended.◀

- If the slope of the road permits, turn the handlebars to the left.
- On a grade, the motorcycle should always face uphill; select 1st gear.

Center stand

– with center stand^{OE}

- Switch off engine.

 If the ground is soft or uneven, there is no guarantee that the motorcycle will rest firmly on the stand.

Always check that the ground under the stand is level and firm.◀

 The center stands could respond to excessively forceful motion by folding back and allowing the vehicle to fall over. Do not sit on the motorcycle while it is resting on the center stand.◀

- Fold out center stand and jack up motorcycle.

Refueling

 Fuel is highly flammable. Fire at the fuel tank can result in fire and explosion. Do not smoke. Never bring a naked flame near the fuel tank.◀

 Fuel expands when exposed to heat. When the tank is overfilled, fuel can escape and get onto the road. This results in a danger of falling. Do not overfill the fuel tank.◀

 Fuel attacks plastic surfaces, making them cloudy or unattractive. Immediately wipe off plastic parts after contact with fuel.◀

- Make sure ground is level and firm and place motorcycle on side stand.

 The available fuel tank volume can only be optimally used with the vehicle standing on the side stand.◀

- Open protective cap.

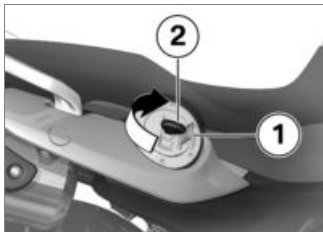



- Unlock cap of fuel tank **1** with motorcycle key and fold open.



- Refuel with quality listed below at most until lower edge of filler neck is reached.

▶ When refueling after running on reserve, make sure that you top up the tank to a level above reserve, as otherwise the sensor will not be able to register the new level and the fuel warning lamp will not be switched off.◀

	Recommended fuel quality
	Regular unleaded, (max. 10 % ethanol, E10) 87 AKI (91 ROZ/RON) 87 AKI
	Usable fuel quantity
	Approx. 3.7 gal (Approx. 14 l)
	Reserve fuel quantity
	Approx. 1.1 gal (Approx. 4 l)

- Press fuel tank cap down firmly to close.
- » Remove key and close protective cap.

Fuel specifications

For optimal fuel economy, the gasoline should be sulfur-free or very low in sulfur content.

 Leaded fuel will destroy the catalytic converter.

Do not refuel with leaded gasoline or gasoline with metallic additives, e. g. manganese or Iron.◀

 Ethanol E85 might damage the engine and fuel supply system.

Do not refuel with E85, i.e. fuel with an ethanol content of 85 %, or with Flex Fuel.◀

- Fuels with a maximum ethanol content of 10 %, i. e., E10, may be used for refueling.



Recommended fuel quality

Regular unleaded, (max. 10 % ethanol, E10)

87 AKI (91 ROZ/RON)

87 AKI

Securing motorcycle for transport

- Protect all component surfaces against which straps are routed against scratching. For example, use adhesive tape or soft cloths.



The motorcycle can tip away to the side and fall over.

Secure motorcycle against tipping to the side, preferably with the assistance of a second person.◀

- Push motorcycle onto transport surface, and do not place on side stand or center stand.

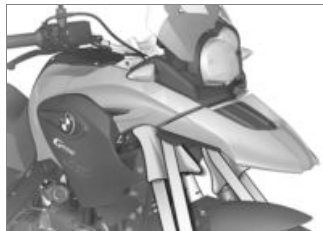

Components can be damaged.

Do not squeeze components such as brake lines or wiring harnesses.◀

- Fasten front straps on both sides on lower fork bridge.



- Fasten rear straps on both sides to the passenger foot-pegs and then tighten them.
- Tension all straps evenly; the motorcycle should be pulled down against its springs with the suspension compressed as much as possible.

Technology in detail

Brake system with BMW Motorrad

ABS 56

Brake system with BMW Motorrad ABS

How does ABS work?

The maximum braking force that can be transferred to the road surface is partially dependent on the friction coefficient of the road surface. Gravel, ice, snow and wet roads offer a considerably poorer friction coefficient than a dry, clean asphalt surface. The poorer the friction coefficient of the road surface is, the longer the braking distance will be. If the maximum transferable braking force is exceeded when the driver increases the brake pressure, the wheels begin to lock and driving stability is lost, and a fall can result. Before this situation occurs, ABS intervenes and adjusts the brake pressure to the maximum transferable braking force. This enables the wheels to continue to turn and maintains

driving stability regardless of the road surface condition.

What happens when rough roads are encountered?

Bumpy or rough roads can briefly lead to a loss of contact between the tires and the road surface, until the transferable braking force is reduced to zero. If braking is carried out in this situation, ABS must reduce the brake pressure to ensure driving stability when restoring contact to the road. At this point in time, the BMW Motorrad ABS must assume extremely low friction coefficients (gravel, ice, snow) so that the running wheels turn in every imaginable case and the driving stability is ensured. After detecting the actual conditions, the system adjusts the optimum brake pressure.

Lifting off rear wheel

Even during severe braking, a high level of tire grip can mean that the front wheel does not lock up until very late, if at all. Consequently, ABS does not intervene until very late, if at all. Under these circumstances the rear wheel can lift off the ground, and the outcome can be a high-siding situation in which the motorcycle can flip over.



Heavy braking can lead to the rear wheel lifting off the ground.

When braking, bear in mind that the ABS control cannot always be relied on to prevent the rear wheel from lifting off the ground.◀

What are the design characteristics of the BMW Motorrad ABS?

The BMW Motorrad ABS ensures driving stability on any surface within the limits of driving physics. The system is not optimized for the special conditions encountered under extreme weather during off-road and race-track use.

Special situations

To detect the tendency of the wheels to lock up, the speeds of the front and rear wheel are compared. If implausible values are detected over a longer period of time, the ABS function is deactivated for safety reasons and an ABS fault is indicated. A self-diagnosis routine must be completed before the error will be displayed.

In addition to problems on the BMW Motorrad ABS, unusual

driving conditions can also lead to a fault message.

Unusual riding conditions:

- Driving on the rear wheel (wheely) for a longer period.
- Rear wheel spinning in place with front brake engaged (burn out).
- Warm-up on the center or auxiliary stand at idle or with gear engaged.
- Locked-up rear wheel for a longer period of time, e.g. when riding downhill offroad.

Should a fault code result due to one of the driving conditions described above, the ABS function can be reactivated by switching the ignition off and then on again.

How important is regular maintenance?



Any technical system is always only as good as its maintenance condition.

To ensure that the BMW Motorrad ABS is in an optimally maintained condition, it is vital that the specified running-in checks be complied with. ◀

Reserves for safety

But remember: the potentially shorter braking distances which BMW Motorrad ABS permits must not be used as an excuse for careless riding. ABS is primarily a means of ensuring a safety margin in genuine emergencies.

Be careful in curves! When you apply the brakes on a corner, the motorcycle's weight and momentum take over and even

BMW Motorrad ABS is unable to counteract their effects.

Accessories

General instructions.....	60
Onboard sockets	60
Case	61
Topcase	64

General instructions

BMW Motorrad recommends the use of parts and accessories for your motorcycle that are approved by BMW for this purpose. Your authorized BMW Motorrad retailer is the right place to go for genuine BMW parts and accessories, other BMW approved products, and expert advice on their installation and use.

These parts and products have been tested by BMW for safety, function and suitability. BMW accepts product liability for these products.

Conversely, BMW is unable to accept any liability whatsoever for parts and accessories which it has not approved.

Observe the information on the importance of tire sizes for chassis control systems (►► 78).



BMW Motorrad cannot examine or test each product of outside origin to ensure that it can be used on or in connection with BMW motorcycles without constituting a safety hazard. Nor is this guarantee provided when the official approval of a specific country has been granted. Tests conducted by these instances cannot make provision for all operating conditions experienced by BMW motorcycles and, consequently, they are not sufficient in some circumstances.

Use only parts and accessories approved by BMW for your motorcycle. ◀

Whenever you are planning modifications, comply with all the legal requirements. The vehicle must not violate the regulations governing vehicle approval for highway use applicable in your own country.

Your authorized BMW Motorrad retailer offers you qualified advice in choosing genuine BMW parts, accessories and other products. You will find all BMW Motorrad optional accessories on our website:

"www.bmw-motorrad.com".

Onboard sockets

Information on using onboard sockets:

Ratings

The load of the onboard sockets may not exceed the value specified in the technical data.

Operating electrical accessories

The operation of additional devices is a strain on the battery. The starting capacity of the battery must be maintained.

Cable routing

The cables from the onboard sockets to the auxiliary devices must be routed in such a way that they:

- Do not impede the rider
- Do not restrict the steering angle and the driving characteristics
- Cannot be trapped

Case

- with Vario case^{OA}

Opening case



- Turn key **1** in case lock perpendicular to direction of travel.
- Hold down yellow locking device **2** and fold out carrying handle **3**.



- Press yellow button **4** downward while pulling case lid outward.

Closing case

- Turn key in case lock perpendicular to direction of travel.



- Close case lid.
» The lid clicks audibly into place.



If the carrying handle is folded down when the slot of the case lock is oriented in the direction of travel, the lock tab can be damaged.

Before folding down the carrying handle, make sure that the slot of the case lock is perpendicular to the direction of travel. ◀

- Fold carrying handle closed **3** downward.
- Turn key in case lock in the direction of travel and remove.

Adjusting case volume

- Open case and empty completely.

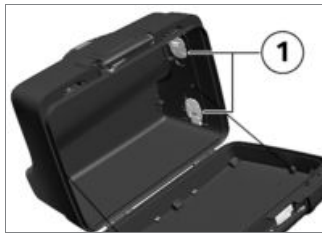

- Release locking levers **1** on left and right from detent and fold up.
- Slide outer case sleeve as far as possible inward or outward, depending on desired case volume.

▶ The locking levers can only be closed if the outer case sleeve is positioned at one of the two stops. ◀

- Close locking levers **1** on left and right and engage.
- Closing case.

Removing case



- Turn key **1** in case lock perpendicular to direction of travel.
- Hold down yellow locking device **2** and fold out carrying handle **3**.



- Pull up red release lever **4**.
» Locking flap **5** pops up.
- Fold locking flap all the way open.
- Remove case from mount by its handle.

Mounting case



- Fold up locking flap **5** completely by pulling red release lever **4** upward if necessary.



- Hook case into case carrier **6**.

- Turn case toward motorcycle while sliding mounting on case as far as possible onto mushroom-headed fastener **7**.



- Press locking flap **5** downward as far as possible and hold in place.
- Press red release lever **4** downward.
» Locking flap clicks into place.
- Fold carrying handle down.
- Turn key in direction of travel and remove.

Topcase

– with Topcase^{OA}

Opening the Topcase



- Unlock Topcase lock **1** if necessary.
- Pull locking lever **2** upward and open Topcase lid.

Closing the Topcase

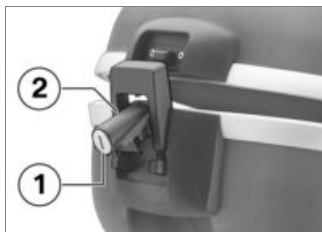

- Close Topcase lid and hold it down.
- Press locking lever **2** completely downward.
- Lock Topcase lock **1** if necessary.

Removing Topcase

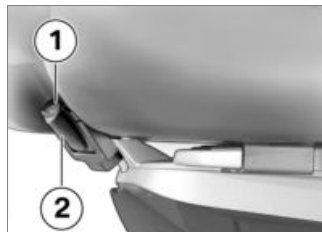

- Unlock Topcase lock **1** if necessary.
- Press locking lever **2** down.
- Pull Topcase toward rear off luggage rack.

Mounting Topcase



- Slide Topcase with guides **3** onto adapter plate as far as possible.

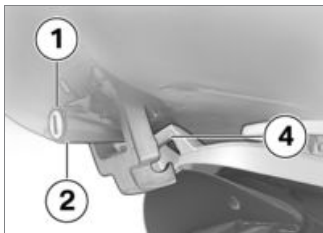

- Press locking lever **2** upward while making sure that lever at

position **4** grips into adapter plate.

- » Locking lever audibly engages.
- Lock Topcase lock **1** if necessary.

Maintenance

General instructions.....	68
Onboard toolkit	68
Engine oil	68
Brake system	70
Coolant	74
Clutch	75
Chain	75
Wheels	77
BMW Motorrad front wheel stand	82
Fuses.....	84
Bulbs	85
Air filter	90
Jump-starting.....	92
Battery.....	93

Fairings and panels	96
---------------------------	----

General instructions

The "Maintenance" chapter describes work involving the checking and replacement of wear parts that can be performed with a minimum of effort.

If special tightening torques are to be taken into account for assembly, these are listed. An overview of all required tightening torques is contained in the chapter "Technical Data".

Information on additional maintenance and repair work is provided in the Repair Manual for your motorcycle on DVD, which you can obtain from your authorized BMW Motorrad retailer.

Special tools and thorough specialized knowledge are required to carry out some of the work described here. If you are in doubt, consult an authorized workshop, preferably your authorized BMW Motorrad retailer.

Onboard toolkit

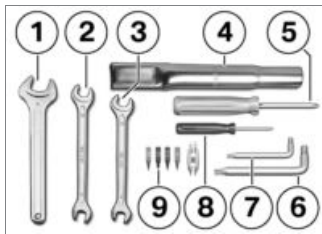

- 1** Open-ended wrench
Wrench size: 24
- 2** Open-ended wrench
Wrench size: 17/19
- 3** Open-ended wrench
Wrench size: 14/19
- 4** Spark plug wrench
- 5** Reversible screwdriver with Phillips and straight blade
- 6** Torx wrench, T45
- 7** TORX wrench, T25
- 8** Small screwdriver with Phillips blade

- 9** Spare fuses with gripper
Miniature fuses: 4 A, 7.5 A, 10 A and 15 A

Engine oil

Checking engine oil level

- Wipe area around oil fill location to clean it.
- Make sure ground is level and firm and hold motorcycle at operating temperature vertically. – with center stand^{OE}
- Make sure ground is level and firm and place motorcycle at operating temperature on its center stand.<
- Allow engine to idle until fan starts, then continue to let engine run for an additional three minutes.
- Switch off engine.



- Position spark plug wrench and interchangeable screwdriver (toolkit) on oil dipstick **1**.
- Remove oil dipstick **1** counter-clockwise.

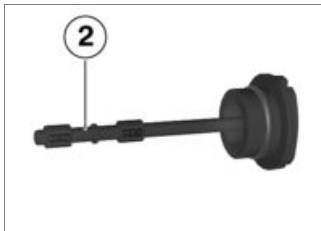

- Clean measuring range **2** of oil dipstick with a dry cloth.
- Position oil dipstick on oil filler opening, but do not screw in.
- Remove oil dipstick and read fluid level.

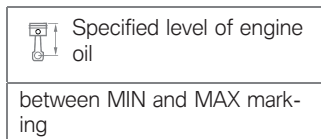
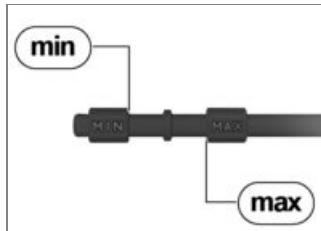

If the oil level is below MIN mark:

- Topping up engine oil (➡ 70).

If oil level is above MAX mark:

- Have fluid level corrected by an authorized workshop, preferably an authorized BMW Motorrad retailer.

Topping up engine oil

- Park motorcycle, ensuring that support surface is firm and level.
- Clean area adjacent to oil fill location.



- Position spark plug wrench and interchangeable screwdriver (toolkit) on oil dipstick **1**.
- Remove oil dipstick **1** counter-clockwise.



Both too little and too much engine oil can lead to engine damage.

Always make sure that the oil level is correct.◀

- Add engine oil up to specified level.
- Check engine oil level (▶▶ 68).
- Install oil dipstick.

Brake system

Checking brake operation

- Actuate the handbrake lever.
 - » Pressure point must be clearly perceptible.
- Actuate the footbrake lever.
 - » Pressure point must be clearly perceptible.

If no clear pressure points are perceptible:

- Have the brakes checked at an authorized workshop, preferably an authorized BMW Motorrad retailer.

Checking front brake pad thickness

- Park motorcycle, ensuring that support surface is firm and level.



- Conduct a visual inspection of the brake pad thickness. Inspection direction: Look between wheel and front suspension to view the brake pads.



 Front brake-pad wear limit

min 0.04 in (min 1.0 mm)
(Only friction material without carrier plate. Wear markings (grooves) must be clearly visible.)

If the wear indicators are no longer clearly visible:

 Dropping below the minimum pad thickness leads to reduced braking performance and may result in damage to the brakes.

In order to ensure the operating

reliability of the brake system, make sure that the brake pads are not worn beyond their minimum thickness. ◀

- Have brake pads replaced at an authorized service facility, preferably an authorized BMW Motorrad retailer.

Checking rear brake pad thickness

- Park motorcycle, ensuring that support surface is firm and level.

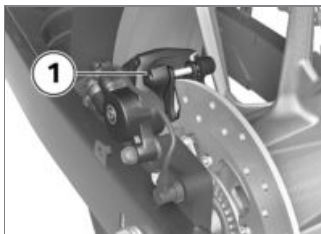

- Conduct a visual inspection of the brake pad thickness. Direc-

tion of view: from rear at brake caliper **1**.

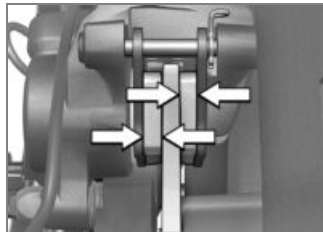

 Rear brake-pad wear limit

min 0.04 in (min 1.0 mm)
(Only friction material without carrier plate.)

If the wear indicating mark is no longer visible:

 Dropping below the minimum pad thickness leads to reduced braking performance and may result in damage to the brakes.

In order to ensure the operating reliability of the brake system, make sure that the brake pads are not worn beyond their minimum thickness. ◀

- Have brake pads replaced by a specialist service facility, preferably an authorized BMW Motorrad retailer.

Checking front brake fluid level



A low fluid level in the brake reservoir can allow air to penetrate the brake system. This significantly reduces braking efficiency.

Check brake fluid level regularly. ◀

- Make sure ground is level and firm and hold motorcycle vertically.

– with center stand^{OE}

- Make sure ground is level and firm and place motorcycle on its center stand. ◀



- Check brake fluid level in front brake-fluid reservoir **1**.

▶ The brake fluid level in the brake-fluid reservoir drops due to brake pad wear. ◀

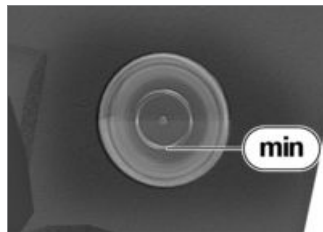

Front brake fluid level

Brake fluid, DOT4

The brake fluid level must not fall below the MIN mark. (Brake-fluid reservoir horizontal)

If brake fluid level falls below the approved level:

- Have defect corrected as soon as possible by an authorized workshop, preferably an authorized BMW Motorrad retailer.

Checking rear brake fluid level

 A low fluid level in the brake reservoir can allow air to penetrate the brake system. This significantly reduces braking efficiency.

Check brake fluid level regularly.◀

- Make sure ground is level and firm and hold motorcycle vertically.
– with center stand^{OE}
- Make sure ground is level and firm and place motorcycle on its center stand.◀

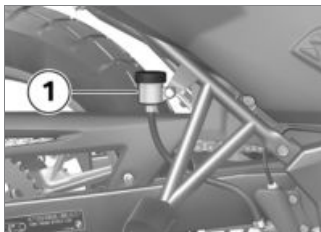

- Read brake fluid level at rear brake-fluid reservoir **1**.

 The brake fluid level in the brake-fluid reservoir drops due to brake pad wear.◀



 Rear brake fluid level

Brake fluid, DOT4

The brake fluid level must not fall below the MIN mark. (Brake-fluid reservoir horizontal)

If brake fluid level falls below the approved level:

- Have defect corrected as soon as possible by an authorized workshop, preferably an authorized BMW Motorrad retailer.

Coolant

Checking coolant level

- Make sure ground is level and firm and park motorcycle.



Danger of burns on hot engine.

Maintain distance from hot engine.

Do not touch hot engine. ◀

- Read off the coolant level through the recessed GS lettering on the expansion tank **1**.

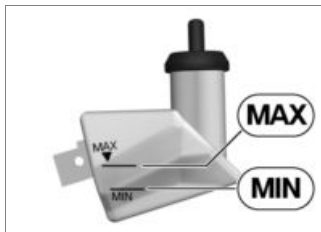

Coolant, specified level

between MIN and MAX marks on the expansion tank

If coolant level drops below permissible level:

- Add coolant.

Topping up coolant

- Removing left fairing side panel (▣▣▣ 98).



- Open cap **1** of coolant expansion tank and add coolant up to specified level.
- Checking coolant level (▣▣▣ 74).
- Close cap of coolant expansion tank.
- Installing left side panel fairing (▣▣▣ 99).

Clutch

Checking clutch lever play

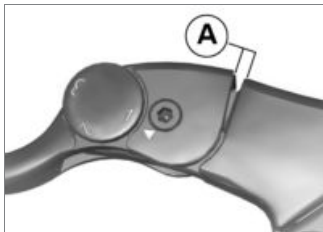

- Pull clutch lever until resistance is felt.
- Measure clutch lever play **A**.



Clutch hand-lever play

0.04...0.08 in (1.0...2.0 mm)

If clutch lever play is outside tolerance:

- Adjusting clutch lever play (►► 75).

Adjusting clutch lever play

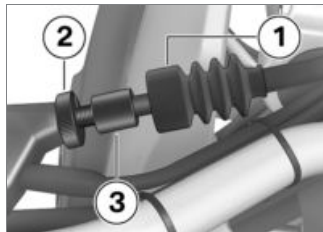

- Push back the rubber boot **1**.
- Loosen the nut **2**.
- To increase clutch play: screw in adjusting screw **3** clockwise.
- To decrease clutch play: turn adjusting screw **3** counter-clockwise.
- Checking clutch lever play (►► 75).
- Repeat work steps until clutch play is correctly adjusted.
- Tighten nut **2**.
- Pull rubber boot **1** over adjusting screw.

Chain

Lubricating chain



Dirt, dust and insufficient lubrication will considerably shorten the service life of the drive chain.

Clean and lubricate the drive chain regularly. ◀

- Lubricate drive chain at least every 620 mls (1,000 km). After driving through water or dust and dirt, carry out lubrication earlier accordingly.
- Switch off ignition and engage Neutral.
- Clean drive chain with suitable cleaning agent, dry and apply chain lubricant.
- Wipe off excess lubricant.

Checking chain sag

- Make sure ground is level and firm and park motorcycle.

- Turn the rear wheel until the position with the lowest chain sag is reached.

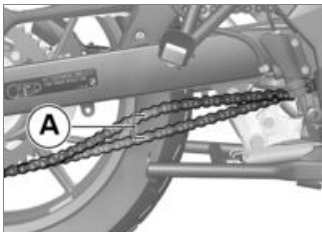

- Press chain upward and downward using a screwdriver and measure difference **A**.



Chain sag

1.4...1.8 in (35...45 mm) (Motorcycle unloaded on center stand)

If the measured value is outside the permissible tolerance:

- Adjusting chain sag (➡ 76).

Adjusting chain sag

- Make sure ground is level and firm and park motorcycle.

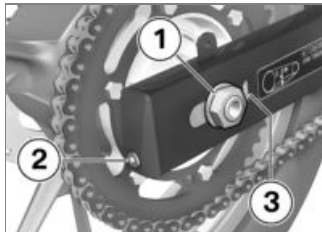

- Loosen quick-release axle nut **1**, while holding on left side if necessary.
- Adjust chain sag with adjusting screws **2** on left and right.
- Checking chain sag (➡ 75).
- Make sure that the same scale value **3** is set on the left and right.

- Tighten quick-release axle nut **1** with specified torque, while holding on left side if necessary.



Nut on quick-release axle (rear wheel)

74 lb/ft (100 Nm)

Checking chain wear

- Park motorcycle, ensuring that support surface is firm and level.



Increased wear.

If wear is identified on a component of the sprocket set, the entire set must be replaced. ◀

- Pull chain toward rear at rear-most point of chain sprocket.
» The tooth tips must still be within the chain links.

If the chain can be pulled off beyond the tooth tips:

- Please contact a specialist service facility, preferably an authorized BMW Motorrad Dealer.

Wheels

Check wheel rims

- Park the motorcycle, ensuring that the support surface is firm and level.
- Subject wheel rims to visual inspection for defects.
- Have damaged rims checked and, if necessary, replaced by a specialist service facility, preferably an authorized BMW Motorrad retailer.

Checking spokes

– with spoke wheel^{OE}

- Park motorcycle, ensuring that support surface is firm and level.
- Sweep across spokes with a screwdriver handle or similar item, paying attention to the sound that they emit as you proceed.

If the tone does not remain consistent:

- Have spokes checked by an authorized service facility, preferably an authorized BMW Motorrad retailer.

Checking tire tread depth



The handling of your motorcycle can already change for the worse before the legally prescribed minimum tread depth is reached.

Have tires replaced even before the minimum tread depth is reached. ◀

- Make sure ground is level and firm and park motorcycle.
- Measure tire tread depth in main tread grooves with wear indicators.



Tread wear marks are integrated into the main grooves on every tire. If the tire tread has worn down to the

level of the marks, the tire is completely worn. The locations of the marks are indicated on the edge of the tire, e.g. by the letters TI, TWI or by an arrow.◀

When the minimum tread depth is reached:

- Replace the worn tires.

Tire recommendation

For every size of tire, BMW Motorrad has tested and approved certain makes as roadworthy. BMW Motorrad cannot evaluate the suitability of other tires, and can therefore take no responsibility for their driving safety.

BMW Motorrad recommends only using the tires tested and approved by BMW Motorrad. Extensive information is available at your authorized BMW Motorrad retailer or on the Internet at www.bmw-motorrad.com.

Affect of wheel sizes on suspension control systems

The wheel sizes play a major role with the ABS system. The diameter and width of the wheels stored in the control unit have particular significance as the basis for all necessary calculations. A change in these sizes due to conversion to others than the wheels installed as standard equipment can seriously affect the control comfort of the system.

The sensor wheels required for wheel speed detection must also match the system installed and may not be replaced.

If you want to equip your motorcycle with different wheels, please contact a specialist service facility, preferably a BMW Motorrad Dealer. In some cases the data stored in the

control unit can be adapted to the new wheel sizes.

Removing front wheel

- Make sure ground is level and firm and place motorcycle on a suitable auxiliary stand.
 - with center stand^{OE}
- Place motorcycle on center stand, ensuring that it is resting on a firm and level support surface.◀

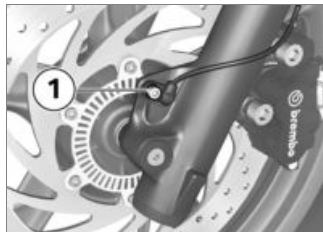

- Remove screw **1** and extract ABS sensor from its socket. Note whether or not a washer is installed.

- Raise front of motorcycle, preferably using a BMW Motorrad front wheel stand, continuing until the wheel rotates freely.
- Mount front wheel stand (→ 82).



- Remove axle clamping screw **2**.
- Remove axle **3** while supporting wheel.
- Do not remove grease on axle.
- When rolling out front wheel take care to avoid damaging ABS sensor and its wire.

- Roll front wheel forward to remove it.



- Remove shims **4** and **5** from wheel hub.

Installing front wheel

 Threaded fasteners not tightened to the specified torque can work loose or their threads can suffer damage. Always have the tightening torques checked by a specialized workshop, preferably an authorized BMW Motorrad retailer. ◀



- Mount shims **5** and **4** on wheel hub.
- Make sure that wheel speed sensor is not damaged when installing front wheel.
- Roll front wheel into front suspension while guiding brake disk between brake pads.



- Lift front wheel and install axle **3** with appropriate torque.



Quick-release axle in telescopic fork

33 lb/ft (45 Nm)

- Remove front wheel stand.
- Squeeze handbrake lever and firmly compress spring forks several times.
- Tighten axle clamping screw **2** to specified torque.



Clamping of front quick-release axle

14 lb/ft (19 Nm)

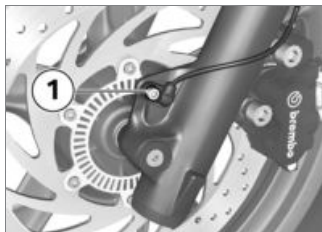

- Insert wheel speed sensor in bore and install screw **1**. Insert washer if one was installed.

- without center stand^{OE}
- Remove auxiliary stand.<1

Removing rear wheel

- Make sure ground is level and firm and place motorcycle on a suitable auxiliary stand.
- with center stand^{OE}
- Place motorcycle on center stand, ensuring that it is resting on a firm and level support surface.<1



- Detach screw **1** and extract wheel speed sensor from its bracket; a washer may also be installed at this location.



- Remove nut **2**, applying counterpressure on left side.

- Loosen adjusting screws **3** on left and right by turning counterclockwise.

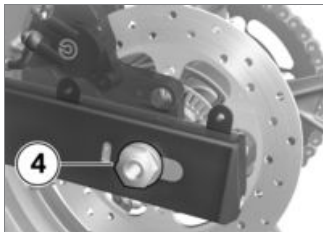

- Support rear wheel (with a suitable block of wood, etc.) and remove quick-release axle **4**.



- Push wheel as far forward as possible and remove chain from chain sprocket **5**.
- Roll rear wheel out of swing arm toward rear while holding brake caliper on left side.

▷ The chain sprocket and the spacer sleeves on the left and right are loosely inserted in the wheel. When removing, make sure that these parts are not damaged or lost.◀

Installing rear wheel



- Make sure that brake caliper runs in guide **6**.
- Roll rear wheel into swing arm while guiding brake rotor between brake pads.



- Roll rear wheel as far forward as possible and lay chain on chain sprocket **5**.

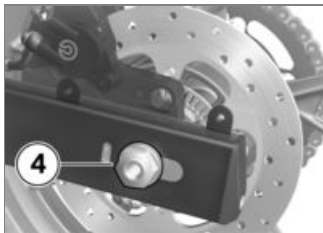

- Raise the rear wheel (or support it with a suitable wooden block) and guide the quick-release axle **4** through the swing

arm, the brake caliper and the rear wheel.



- Install axle nut **2** but do not yet tighten it down.



- Insert wheel speed sensor in bracket and install screw **1**, with shim as required.
- Adjusting chain sag (➡ 76).

- without center stand^{OE}
- Remove auxiliary stand.<

BMW Motorrad front wheel stand

Mounting front wheel stand



The BMW Motorrad front wheel stand is not designed to support the motorcycle without the assistance of an auxiliary

stand. A motorcycle standing on the front wheel stand and the rear wheel alone can fall over. Place the motorcycle on an auxiliary stand before lifting the front wheel with the BMW Motorrad front-wheel stand.◀

- Place motorcycle on a suitable auxiliary stand.
 - with center stand^{OE}
- Place motorcycle on center stand, ensuring that it is resting on a firm and level support surface.◁
- Use basic stand with tool number (83 30 0 402 241) in combination with front-wheel adapter (83 30 0 402 242).

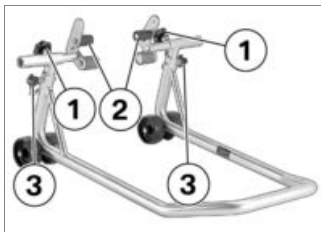

- Loosen mounting bolts **1**.
- Push two mounts **2** outward, continuing until front suspension fits between them. Adjust support pin to match front suspension.
- Use locating pins **3** to set front wheel stand to desired height.
- Center front wheel stand relative to front wheel and push it against front axle.



- Install rubber buffer **4** on left and right in upper position.

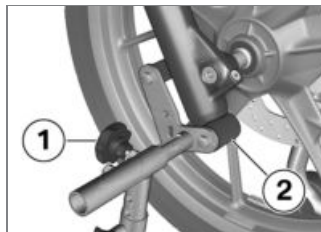

- Align two mounts **2** so that front suspension rests securely on them.
- Tighten securing screws **1**.



- Apply uniform pressure to push front wheel stand down and raise motorcycle.

– with center stand^{OE}

! If the motorcycle is raised too far at the front the center stand will lift clear of the ground and the motorcycle could topple to one side.

When raising the motorcycle, make sure that the center stand remains on the ground. Adjust the height of the front wheel stand if necessary.◀

- Ensure that motorcycle is standing securely.◀

Fuses

Removing fuse

! If defective fuses are bridged, this results in a danger of short-circuit and thus a danger of fire.

Replace defective fuses with new fuses.◀

- Switch off ignition.
- Remove seat (→ 38).



- Press together locking levers **1** and remove fuse cover.

- Pull defective fuse upward out of fuse box with toolkit.

▶ If the fuses blow frequently, have the electrical system checked by an authorized specialized workshop, preferably an authorized BMW Motorrad retailer.◀

Installing fuse

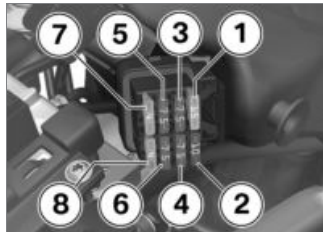

- Replace defective fuse with fuse with required amperage.

▶ An overview of the fuse assignment and the required amperages is provided in the chapter "Technical Data". The

numbers in the graphic match the fuse numbers.◀

- Close fuse cover.
- » Latch audibly engages.
- Install seat (▣▣▣ 39).

Bulbs

Replacing low and high-beam bulbs in headlight

- Make sure ground is level and firm and park motorcycle.



- Remove screw **1** and pull instrument cluster upward out of holders.

- Set down instrument cluster on side.
- Switch off ignition.



- Pull off the connector **1** while bracing the bulb located under the rubber cap.



- Remove rubber cap **2**.



- Remove spring strap **3** from detents and fold up.
- Remove bulb **4**.

- Replace defective bulb.

 Bulb for low-beam and high-beam headlight

H4 / 12 V / 55 W / 60 W

- To avoid leaving contamination deposits on the new bulb's glass surface, always hold it by its base.

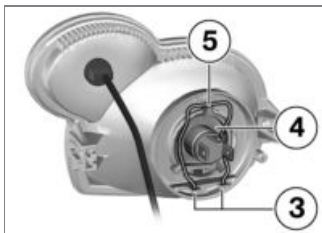

- Install bulb **4** while ensuring correct position of lug **5**.
- Insert spring clip **3**.



- Mount rubber cap **2**.



- Close plug connection **1**.

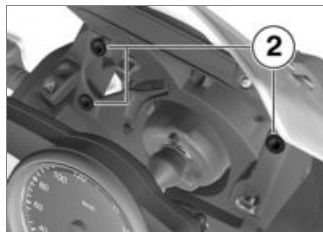

- Mount instrument cluster in holders **2**.



- Install screw **1**.

Replacing parking light bulb

- Park the motorcycle, ensuring that the support surface is firm and level.
- Switch off ignition.
- Remove the instrument cluster using the procedure described in the previous section.



- Pull bulb socket **1** out of headlight housing.



- Remove bulb from socket.
- Replace defective bulb.



Bulb for parking light

W5W / 12 V / 5 W

- To protect the glass on the new bulb against contamination, always use a clean, dry cloth to hold it; do not touch with bare fingers.



- Insert bulb in socket.



- Insert the bulb socket **1** in the headlight housing.
- Install the instrument cluster using the procedure described in the previous section.

Replacing front and rear turn indicator bulbs

- Park the motorcycle, ensuring that the support surface is firm and level.
- Switch off ignition.



- Remove screw **1**.



- Pull glass on screw connection side out of mirror housing.

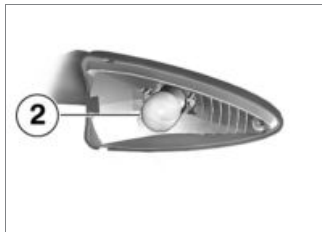

- Remove bulb **2** from light housing by turning it counterclockwise.

- Replace defective bulb.



Bulbs for flashing turn indicators, front

RY10W / 12 V / 10 W



Bulbs for flashing turn indicators, rear

RY10W / 12 V / 10 W

- To protect the glass on the new bulb against contamination, always use a clean, dry cloth to hold it; do not touch with bare fingers.

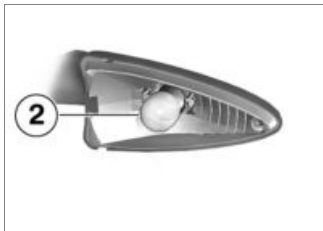

- Install bulb **2** by screwing clockwise into light housing.



- Install screw **1**.

Replacing tail light and brake light bulb

- Park motorcycle, ensuring that support surface is firm and level.
- Switch off ignition.



- Insert inside end of lens into light housing and close.

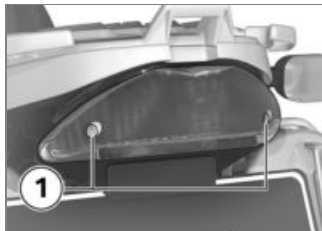

- Remove two screws **1** and take off taillight lens.



- Press bulb **2** into socket and turn counterclockwise to remove.

- Replacing defective bulb.



Bulb for taillight/brake light

P25-2 / 12 V / 5 W / 21 W

- To protect glass on new bulb against contamination, always use a clean, dry cloth to hold it; do not touch with bare fingers.



- Press bulb **2** into socket and install by turning clockwise.

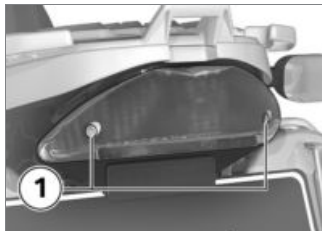

- Position taillight lens and install two screws **1**.

Air filter

Replacing air filter insert

- Removing right fairing side panel (→ 97).

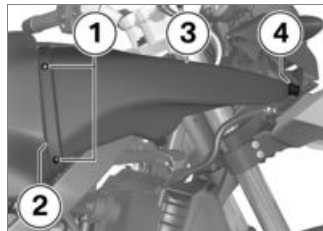

- Remove two screws **1**.
- Pull out connecting flange **2**.
- Pull suction pipe **3** off air filter housing, take out of mount **4** and turn to side.



- Disconnect plug **5**.



- Remove air filter insert **6**.



- Close connector **5**.



- Insert suction pipe in guides **7** of air filter housing. Make sure rubber gaskets of air filter insert are not folded.

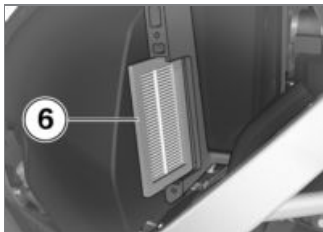

- Insert cleaned or new air filter insert **6**.



- Insert suction pipe in mount **4**.



- Insert connecting flange **2**.
- Install two screws **1**.

- Install right fairing side panel (▮▮▮ 98).

Jump-starting

! The wires leading to the power socket do not have a load-capacity rating adequate for jump-starting the engine. Excessively high current can lead to a cable fire or damage to the vehicle electronics.

Do not use the socket to jump-start the engine of the motorcycle. ◀

! A short-circuit can result if the crocodile clips of the jump leads are accidentally brought into contact with the motorcycle.

Use only jump leads fitted with fully insulated crocodile clips at both ends. ◀

! Jump-starting with a donor-battery voltage higher than

12 V can damage the motorcycle electronics.

The battery of the donor vehicle must have a voltage of 12 V. ◀

- Park motorcycle, ensuring that support surface is firm and level.
- Remove seat (▮▮▮ 38).
- Removing center fairing panel (▮▮▮ 96).
- Do not disconnect the battery from the onboard electrical system when jump-starting the engine.

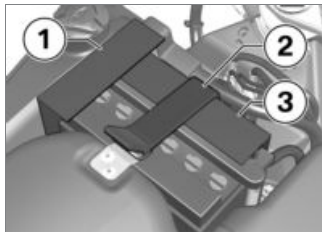

- Detach large heat protection mat **1** from battery.
- Release rubber tensing strap **2** and remove small heat protection mat **3**.



- Slide back cover **1** of positive battery terminal.
- Begin by connecting one end of the red jump lead to positive terminal **2** of discharged battery and other end to positive terminal of donor battery.
- Connect black jumper cable to negative terminal on donor battery and then to negative terminal **3** of discharged battery.
- Allow engine on support motorcycle to run while jump-starting.
- Start engine of vehicle with discharged battery in usual way;

if engine does not start, wait a few minutes before repeating attempt in order to protect starter motor and donor battery.

- Allow both engines to run for several minutes before disconnecting the jumper cables.
- Disconnect jumper cable from negative terminal first, then disconnect second lead from positive terminals.

 To start the engine, do not use start sprays or similar items.◀

- Attach cover panel **1** of positive battery terminal.

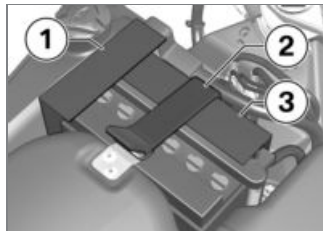

- Mount small heat protection mat **3** with **aluminum side facing outward** and fasten it with rubber tensioning strap **2**.
- Fold large heat protection mat **1** on battery.
- Installing center fairing panel (▮▮▮ 97).
- Install seat (▮▮▮ 39).

Battery

Maintenance instructions

Correct upkeep, recharging and storage will prolong the life of the battery and are essential for recognition of warranty claims.

Compliance with the points below is important in order to maximize battery life:

- Keep the surface of the battery clean and dry
- Be sure to read and comply with the instructions for charging the battery on the following pages
- Do not turn the battery upside down.

 If the battery is not disconnected, the onboard electronics (clock etc.) will drain the battery. This can cause the battery to run flat. If this happens, warranty claims will not be accepted.

During driving breaks of more than 4 weeks, a trickle-charger should be connected to the battery.◀

Charging connected battery

 Charging the connected battery directly at the battery terminals can damage the motorcycle electronics. To charge the battery via the battery terminals, disconnect the battery first.◀

 If the multifunction display and indicator lamps fail to light up when you switch on the ignition, the battery is completely discharged (battery voltage below 9 V). Attempts to recharge a completely discharged battery through the onboard power socket can damage the motorcycle's electronic systems. Always charge a completely drained battery directly at the terminals of the disconnected battery.◀

- Only charge connected battery via onboard socket.

- Comply with operating instructions of charger.

Charging disconnected battery

- Charge battery using a suitable charger.
- Comply with operating instructions of charger.
- Once battery is fully charged, disconnect charger's terminal clips from battery terminals.

 In the case of longer periods when the motorcycle is not being used, the battery must be recharged regularly. See the instructions for caring for your battery. Always fully recharge the battery before returning it to use.◀

Remove battery

- Park the motorcycle, ensuring that the support surface is firm and level.

– with anti-theft alarm^{OE}

- Switch off anti-theft alarm system if necessary.◀
- Switch off ignition.
- Removing center fairing panel (▶▶ 96).

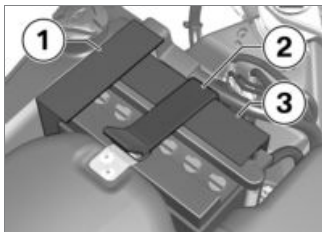

- Detach the large heat protection mat **1** from the battery.
- Release the rubber tensioning strap **2** and remove the small heat protection mat **3**.

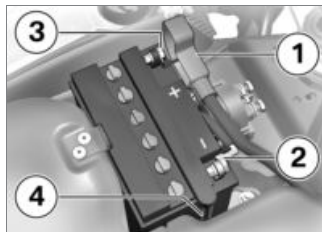

- Slide back cover **1** of positive battery terminal.

⚠ An incorrect disconnection sequence increase the risk of short-circuiting.

Always observe the proper sequence.◀

- Remove negative cable **2** first.
- Then remove the positive battery cable **3**.
- Remove the bleeder hose **4**.
- Lift out battery upward; if it is difficult to move, moving it back and forth will help.

Installing battery

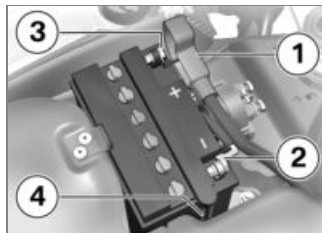

- Install battery and attach bleeding hose **4** when doing so.
- First install positive cable **3**.
- Then install negative cable **2**.
- Slide cover **1** over positive battery terminal.

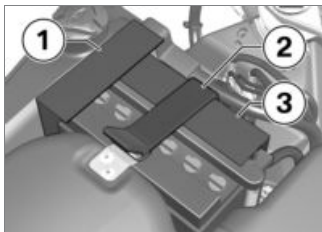

- Mount the small heat protection mat **3** with **the aluminum side facing outward** and fasten it with the rubber tensioning strap **2**.
- Fold the large heat protection mat **1** on the battery.
- Installing center fairing panel (▣ 97).
- Setting clock (▣ 29).

Checking battery acid level

- Check acid level approximately every three months.

- Remove battery (▣ 94).

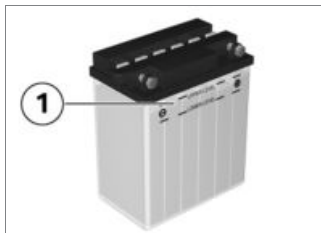

- Read off acid level from marking **1**.

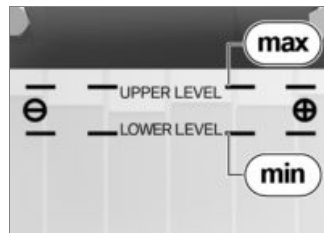

 Setpoint level of battery acid

between MIN and MAX marking

If acid level is below MIN marking:

- Add distilled water up to specified level.

Fairings and panels

Removing center fairing panel

- Make sure ground is level and firm and park motorcycle.

- Remove seat (▮▮▮ 38).

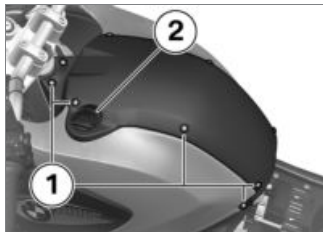

- Remove screws **1** on left and right.
- Extract the oil dipstick **2** and remove the center fairing panel section.
- Install oil dipstick.

Installing center fairing panel



- Remove oil dipstick **2**.

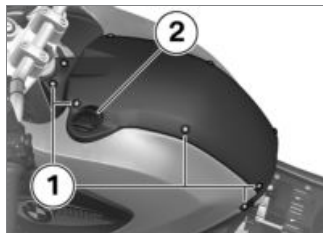

- Position center fairing panel and install oil dipstick **2**.

- Install the screws **1** on the left and right sides, starting with the center screw.
- Install seat (▮▮▮ 39).

Removing right fairing side panel

- Make sure ground is level and firm and park motorcycle.
- Removing center fairing panel (▮▮▮ 96).



- Remove screws **1** and **2**.



- Remove screw **3**.
- Pull the side fairing panel in the sector **4** from its support and remove it.

Installing right fairing side panel



- Mount fairing side panel in mount **4**.



- Install screw **3**.



- Install screws **1** and **2**.
- Installing center fairing panel (▮▮▮ 97).

Removing left fairing side panel

- Make sure ground is level and firm and park motorcycle.
- Removing center fairing panel (▮▮▮ 96).

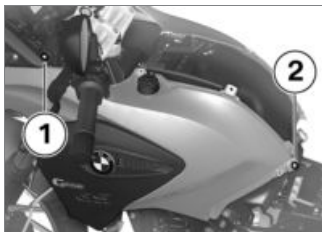

- Remove screws **1** and **2**.



- Remove screw **3**.
- Pull the side fairing panel in the sector **4** from its support and remove it.

Installing left side panel fairing



- Slide the fairing side panel behind the upper section of fairing **5** then insert it in the fixture **4**



- Install screw **3**.

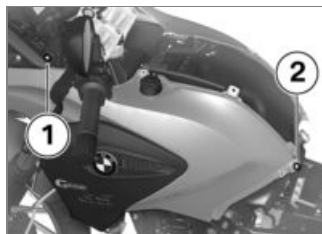

- Install screws **1** and **2**.
- Installing center fairing panel (→ 97).

Care

Care products	102
Washing your motorcycle	102
Cleaning sensitive motorcycle parts	102
Paint care	103
Storing the motorcycle.....	104
Protective wax coating	104
Returning motorcycle to use	104

Care products

BMW Motorrad recommends that you use cleaning and care products available at your authorized BMW Motorrad retailer. BMW Care Products have been materials tested, laboratory tested, and field tested and provide optimum care and protection for the materials used in your motorcycle.

 The use of unsuitable products for cleaning and care can damage motorcycle components.

For cleaning, do not use any solvents such as nitro-thinners, cold cleaning agents, fuel or similar, and do not use cleaning agents that contain alcohol. ◀

Washing your motorcycle

BMW Motorrad recommends that you use BMW Insect Remover to soften and wash off insects and stubborn dirt from painted parts before washing the motorcycle.

To prevent stains, do not wash the motorcycle immediately after it has been exposed to bright sunlight and do not wash it in the sun.

Make sure that the motorcycle is washed frequently, especially during the winter months.

To remove road salt, clean the motorcycle with cold water immediately after completion of every trip.

 After washing the motorcycle, after driving through water or in the rain, braking can be delayed owing to damp brake rotors and brake pads.

Brake early until the brake rotors and brake pads are dry. ◀

 Warm water intensifies the effect of salt.

Only use cold water to remove road salt. ◀

 The high water pressure from high-pressure cleaners (steam blasters) can result in damage to seals, the hydraulic brake system, the electrics and the seat.

Do not use high-pressure or steam-jet devices! ◀

Cleaning sensitive motorcycle parts

Plastics

 If plastic parts are cleaned using unsuitable cleaning agents, the surfaces can be damaged.

Do not use cleaning agents that

contain alcohol, solvents or abrasives to clean plastic parts. 'Insect sponges' or sponges with hard surfaces can also lead to scratches. ◀

Fairings

Clean body panels with water and BMW plastic care emulsion.

Plastic windshields and headlight lenses

Clean off dirt and insects with a soft sponge and plenty of water.

 Soften stubborn dirt and dead insects by covering the affected areas with a wet cloth. ◀

Chrome

Especially in the case of road salt, carefully clean chrome parts with plenty of water and BMW auto shampoo. Use chrome polish for additional treatment.

Radiator

Clean the radiator regularly to prevent overheating of the engine due to inadequate cooling. For example, use a garden hose with low water pressure.



Cooling fins can be bent easily.

When cleaning the radiator, ensure that the fins are not bent. ◀

Rubber

Treat rubber components with water or BMW rubber protection coating agent.



Using silicone sprays for the care of rubber seals can cause damage.

Do not use silicone sprays or care products that contain silicone. ◀

Paint care

Washing the vehicle regularly will help counteract the long-term effects of substances that damage the paint, especially if your vehicle is ridden in areas with high air pollution or natural sources of dirt, e.g. tree resin or pollen. However, remove particularly aggressive materials immediately; otherwise changes in the paint or discoloration can occur. These include spilled fuel, oil, grease and brake fluid as well as bird droppings. BMW Car Polish and BMW Paint Cleaner are recommended for this procedure. Contamination on the paint finish is particularly easy to see after the motorcycle has been washed. Remove this type of soiling with cleaning naphtha or spirit on a clean cloth or cotton ball. BMW Motorrad recommends removing tar spots with BMW Tar Remover. Then add

a protective wax coating to the paint at these locations.

Storing the motorcycle

- Completely fill the motorcycle's fuel tank.
- Clean motorcycle.
- Remove battery (➡ 94).
- Spray the brake and clutch lever, the side stand pivot and, if necessary, the center stand pivot with a suitable lubricant.
- Coat bare metal and chrome-plated parts with an acid-free grease (Vaseline).
- Park motorcycle in a dry room, raising it to remove weight from both wheels.

Protective wax coating

BMW Motorrad recommends that you apply BMW Car Wax or another wax containing carnauba or synthetic wax additives to protect the paintwork.

When water fails to form beads on the paint surface this indicates it is time to apply wax.

Returning motorcycle to use

- Remove the protective wax coating.
- Clean the motorcycle.
- Install a charged battery.
- Observe checklist before starting.

Technical data

Troubleshooting chart	106
Threaded fasteners	107
Engine	109
Fuel.....	110
Engine oil	110
Clutch	111
Transmission	111
Rear-wheel drive.....	112
Suspension	112
Brakes	113
Wheels and tires	113
Electrical system.....	114
Frame	116
Dimensions	117
Weights.....	118

Performance data.....	118
-----------------------	-----

Troubleshooting chart

Engine does not start at all or is very difficult to start.

Possible cause	Remedy
Emergency-off switch (kill switch)	Emergency-off switch (kill switch) in normal operating position.
Side stand extended and gear engaged	Retract side stand.
Gear engaged and clutch not disengaged	Place transmission in neutral or disengage clutch.
No fuel in tank	Refueling (▶▶ 50).
Battery drained	Charge battery.

Threaded fasteners

Front wheel	Value	Valid
Quick-release axle in telescopic fork		
M16 x 1.5	33 lb/ft (45 Nm)	
Clamping of front quick-release axle		
M8 x 20	14 lb/ft (19 Nm)	
Rear wheel	Value	Valid
Nut on quick-release axle (rear wheel)		
M16 x 1.5	74 lb/ft (100 Nm)	
Tensioning screws (drive chain) in swinging arm		
M8 x 70	7 lb/ft (10 Nm)	
Mirror arm	Value	Valid
Locknut (mirror) on clamping piece		
M18 x 1	15 lb/ft (20 Nm)	

Mirror arm	Value	Valid
Clamping piece (mirror) on clamping block		
M10 x 1.25	22 lb/ft (30 Nm)	

Engine

Engine design	Single-cylinder, four-stroke engine, DOHC control with bush roller-chain drive, 4 valves actuated by bucket tappets, compensating shaft, liquid cooling for cylinders and cylinder head. Integrated coolant pump, 5-speed transmission and dry-sump lubrication.
Displacement	652 cc (652 cm ³)
Cylinder bore	3.9 in (100 mm)
Piston stroke	3.3 in (83 mm)
Compression ratio	11.5:1
Rated output	48 hp (35 kW), at engine speed: 6500 min ⁻¹
– with reduced output ^{OA}	34 hp (25 kW), at engine speed: 6500 min ⁻¹
Torque	44 lb/ft (60 Nm), at engine speed: 5000 min ⁻¹
– with reduced output ^{OA}	35 lb/ft (47 Nm), at engine speed: 4500 min ⁻¹
Maximum engine speed	max 7500 min ⁻¹
Idle speed	1500 \pm 100 min ⁻¹

Fuel

Recommended fuel quality	Regular unleaded, (max. 10 % ethanol, E10) 87 AKI (91 ROZ/RON) 87 AKI
Usable fuel quantity	Approx. 3.7 gal (Approx. 14 l)
Reserve fuel quantity	Approx. 1.1 gal (Approx. 4 l)

Engine oil

Engine oil, capacity	2.4 quarts (2.3 l), Total filling quantity (with filter replacement) 0.3 quarts (0.25 l), Difference between MIN and MAX
Specification	SAE 15W-50, API SJ/JASO MA2, Additives (e.g. on a molybdenum basis) are not permitted, as they will attack coated engine components, BMW Motorrad recommends BMW Motorrad ADVANTEC Pro Oil SAE 15W-50

BMW recommends **ADVANTEC**
ORIGINAL BMW ENGINE OIL

Oil grades	BMW Motorrad does not recommend using oil additives, as these can worsen the operation of the clutch. BMW Motorrad recommends not using synthetic oils for the first 6,000 miles (10,000 km). Ask your BMW Motorrad retailer for engine oils suitable for your motorcycle.
------------	--

BMW recommends **ADVANTEC**
ORIGINAL BMW ENGINE OIL

Clutch

Clutch design	Multi-disk oil-bath clutch
---------------	----------------------------

Transmission

Transmission design	Claw-shifted 5-speed transmission integrated in engine housing
Transmission gear ratios	1.946 (72:37 teeth), Primary gear ratio 2.750 (33:12 teeth), 1st gear 1.750 (28:16 teeth), 2nd gear 1.313 (21:16 teeth), 3rd gear 1.045 (23:22 teeth), 4th gear 0.875 (21:24 teeth), 5th gear

Rear-wheel drive

Type of final drive	Chain drive
Type of rear suspension	Two-arm box-section swinging fork
Secondary gear ratio	2,938

Suspension

Type of front suspension	Telescopic forks
Spring travel, front	6.7 in (170 mm), On wheel
– with lowering ^{OE}	5.5 in (140 mm), On wheel
Type of rear suspension	Two-arm box-section swinging fork
Spring travel, rear	6.5 in (165 mm), On wheel
– with lowering ^{OE}	5.1 in (130 mm), On wheel

Brakes

Type of front brake	Hydraulically disk brake with 2-piston floating caliper
Brake-pad material, front	Sintered metal
Type of rear brake	Hydraulically disk brake with 1-piston floating caliper
Brake-pad material, rear	Organic

Wheels and tires

Recommended tire combinations	You can obtain an overview of the current tire approvals from your authorized BMW Motorrad retailer or on the Internet at www.bmw-motorrad.com .
-------------------------------	--

Front wheel

Front wheel design	Cast aluminum, MT H2
– with spoke wheel ^{OE}	Spoke wheel
Front-wheel rim size	2.50" x 19"
Front tire designation	110/80 - 19

Rear wheel

Rear wheel design	Cast aluminum, MT H2
– with spoke wheel ^{OE}	Spoke wheel
Rear-wheel rim size	3.50" x 17"
Rear tire designation	140/80 - 17

Tire inflation pressure

Tire pressure, front	31.9 psi (2.2 bar), With tire cold
Tire pressure, rear	36.3 psi (2.5 bar), Single rider, with cold tire 42.1 psi (2.9 bar), With passenger and payload, with cold tire

Electrical system**Battery**

Battery design	Lead-acid battery
Battery voltage	12 V
Battery capacity	12 Ah

Spark plugs

Spark plugs, manufacturer and designation	NGK DR 8 EB
Electrode gap of spark plug	0.02...0.03 in (0.6...0.7 mm), New

Lights

Bulb for low-beam and high-beam headlight	H4 / 12 V / 55 W / 60 W
Bulb for parking light	W5W / 12 V / 5 W
Bulb for taillight/brake light	P25-2 / 12 V / 5 W / 21 W
Bulbs for flashing turn indicators, front	RY10W / 12 V / 10 W
Bulbs for flashing turn indicators, rear	RY10W / 12 V / 10 W

Fuses

Nominal current of fuse 1 (for engine electronics)	15 A
Nominal current of fuse 2 (for instrument cluster, hazard warning flashers, onboard socket, optional accessories and diagnosis plug)	10 A
Nominal current of fuse 3 (for horn and headlight flasher)	7.5 A
Nominal current of fuse 4 (for low-beam headlight)	7.5 A

Nominal current of fuse 5 (for high-beam head-light)	7.5 A
Nominal current of fuse 6 (for instrument cluster, turn indicators, hazard warning flashers, brake light and optional accessories)	7.5 A
Nominal current of fuse 7 (for tail light and parking lights)	4 A
Nominal current of fuse 8 (for heated handlebar grips)	4 A

Frame

Frame design	Bridge-type tube frame of steel profiles with bolted rear frame
Location of type plate	Upper right main frame
Location of the vehicle identification number	Right steering head

Dimensions

Motorcycle length	85.2 in (2165 mm)
Motorcycle height	54.7 in (1390 mm), without driver at DIN unladen weight
Motorcycle width	36.2 in (920 mm), across mirrors
Rider's seat height	31.5 in (800 mm), without driver at unladen weight
– with lowering ^{OE}	30.3 in (770 mm), without driver at unladen weight
– with high seat ^{OA}	33.1 in (840 mm), without driver at unladen weight
Rider's inside-leg arc, heel to heel	71.3 in (1810 mm), without rider at unladen weight
– with lowering ^{OE}	68.9 in (1750 mm), without rider at unladen weight
– with high seat ^{OA}	74.4 in (1890 mm), without rider at unladen weight

Weights

Unladen weight	423 lbs (192 kg), DIN unladen weight, ready for road, 90 % full tank of gas, without OE
Permissible gross weight	838 lbs (380 kg)
Maximum payload	max 414 lbs (max 188 kg)

Performance data

Top speed	106 mph (170 km/h)
– with reduced output ^{OA}	90 mph (145 km/h)

Service

Reporting safety defects	120
BMW Motorrad Service	121
BMW Motorrad Mobility Services	121
Maintenance procedures	121
Confirmation of maintenance work	123
Confirmation of service	128

Reporting safety defects

If you believe that your vehicle has a defect which could cause a crash or could cause injury or death, you should immediately inform the National Highway Traffic Safety Administration (NHTSA) in addition to notifying BMW of North America, LLC.

If NHTSA receives similar complaints, it may open an investigation, and if it finds that a safety defect exists in a group of vehicles, it may order a recall and remedy campaign. However, NHTSA cannot become involved in individual problems between you, your dealer, or BMW of North America, LCC.

To contact NHTSA, you may call the Vehicle Safety Hotline toll-free at 1-888-327-4236 (TTY: 1-800-424-9153); go to <http://www.safercar.gov>; or write to: Administrator, NHTSA, 400 Seventh Street, SW., Washington, DC 20590. You can also obtain other information about motor vehicle safety from <http://www.safercar.gov>.

BMW Motorrad Service

With its worldwide dealer network, BMW Motorrad can attend to you and your motorcycle in over 100 countries around the globe. Authorized BMW Motorrad retailers have the technical information and the technical know-how needed to conduct reliable service and repairs covering every aspect of your BMW.

You can find the nearest authorized BMW Motorrad retailer by visiting our Internet site at "www.bmw-motorrad.com".



If this maintenance and repair work is performed inexpertly, there is a danger of damage and associated safety risks. BMW Motorrad recommends having corresponding work on your motorcycle carried out by a specialized workshop, preferably

by an authorized BMW Motorrad retailer. ◀

To ensure that your BMW consistently remains in optimal condition BMW Motorrad urges you to observe the recommended service intervals.

Have all maintenance and repair work confirmed in the "Service" chapter in this manual. Documentation confirming regular maintenance is essential for generous treatment of claims submitted after the warranty period has expired (goodwill).

You can obtain information on the contents of the BMW Services from your BMW Motorrad retailer.

BMW Motorrad Mobility Services

The BMW Motorrad Mobility Services furnish you and your new BMW motorcycle with extra security by offering a wide array of assistance services in the event of a breakdown (BMW Roadside Assistance, breakdown assistance, vehicle recovery and retrieval, etc.).

Contact your authorized BMW Motorrad retailer for additional information on available mobility-maintenance services.

Maintenance procedures

BMW Pre-Delivery Check

The BMW pre-delivery check is carried out by your authorized BMW Motorrad retailer before it turns over the motorcycle to you.

BMW Running-in Check

The BMW running-in check must be carried out between 300 mls (500 km) and 750 mls (1,200 km).

BMW Service

BMW Service is carried out once a year. The scope of the services performed may be dependent on the motorcycle owner and the mileage driven. Your BMW Motorrad retailer confirms that the service has been performed and enters the date for the next service.

For riders who drive long distances annually, it may be necessary to come in for service before the entered date. In this case a corresponding maximum odometer reading will also be entered in the confirmation of service. If this odometer reading is reached before the next service date, service must be performed sooner.

Confirmation of maintenance work

BMW Pre-Delivery Check

Conducted

on _____

Stamp, Signature

BMW Running-in Check

Conducted

on _____

Odometer reading _____

Next service
at the latest

on _____

or, if reached sooner,

Odometer reading _____

Stamp, Signature

BMW Service

Conducted

on _____

Odometer reading _____

Next service
at the latest

on _____

or, if reached sooner,

Odometer reading _____

Stamp, Signature**BMW Service**

Conducted

on _____

Odometer reading _____

Next service
at the latest

on _____

or, if reached sooner,

Odometer reading _____

Stamp, Signature**BMW Service**

Conducted

on _____

Odometer reading _____

Next service
at the latest

on _____

or, if reached sooner,

Odometer reading _____

Stamp, Signature

BMW Service

Conducted

on _____

Odometer reading _____

Next service
at the latest

on _____

or, if reached sooner,

Odometer reading _____

Stamp, Signature**BMW Service**

Conducted

on _____

Odometer reading _____

Next service
at the latest

on _____

or, if reached sooner,

Odometer reading _____

Stamp, Signature**BMW Service**

Conducted

on _____

Odometer reading _____

Next service
at the latest

on _____

or, if reached sooner,

Odometer reading _____

Stamp, Signature

BMW Service

Conducted

on _____

Odometer reading _____

Next service
at the latest

on _____

or, if reached sooner,

Odometer reading _____

Stamp, Signature**BMW Service**

Conducted

on _____

Odometer reading _____

Next service
at the latest

on _____

or, if reached sooner,

Odometer reading _____

Stamp, Signature**BMW Service**

Conducted

on _____

Odometer reading _____

Next service
at the latest

on _____

or, if reached sooner,

Odometer reading _____

Stamp, Signature

BMW Service

Conducted

on _____

Odometer reading _____

Next service
at the latest

on _____

or, if reached sooner,

Odometer reading _____

Stamp, Signature**BMW Service**

Conducted

on _____

Odometer reading _____

Next service
at the latest

on _____

or, if reached sooner,

Odometer reading _____

Stamp, Signature**BMW Service**

Conducted

on _____

Odometer reading _____

Next service
at the latest

on _____

or, if reached sooner,

Odometer reading _____

Stamp, Signature

Confirmation of service

The table is intended as proof of maintenance and repair work, the installed optional accessories and any special campaign (recall) work carried out.

Work carried out	Odometer reading	Date

Work carried out	Odometer reading	Date

A

Abbreviations and symbols, 6

ABS

Control, 16

Operating, 33

Self-diagnosis, 46

Technology in detail, 56

Warning lamps, 24

Accessories

General instructions, 60

Air filter

Position in motorcycle, 13

Replacing, 90

Anti-theft alarm system

Indicator light, 15

B**Battery**

Charging connected battery, 94

Charging disconnected
battery, 94

Installing, 95

Maintenance instructions, 93

Position on motorcycle, 11

Removing, 94

Technical data, 114

Brake fluid

Check fluid level at rear, 73

Check front fluid level, 72

Front reservoir, 13

Rear reservoir, 13

Brake pads

Check front, 70

Check rear, 71

Running in, 47

Brakes

Checking operation, 70

Safety instructions, 49

Technical data, 113

Breaking in, 47**Bulbs**

Replacing brake light bulb, 89

Replacing bulb for turn
indicator, 88

Replacing high-beam headlight
bulb, 85

Replacing low-beam bulb in
headlight, 85

Replacing parking light bulb, 87

Replacing tail light bulb, 89

Technical data, 115

C**Case**

Operating, 61

Chain

Adjusting sag, 76

Chain tension label, 13

Check wear, 76

Checking sag, 75

Lubricating, 75

Checklist, 44**Clock**

Adjusting, 29

Control, 15

Clutch

Adjusting handlebar lever, 34

Adjusting play, 75

Checking play, 75

Technical data, 111

**Confirmation of maintenance
work, 123****Coolant**

Checking fill level, 74

Fill level indicator, 11

Overheating warning
indicator, 24

Topping up, 74

D

- Damping
 - Adjusting, 36
 - Adjustment element, 13
- Dimensions
 - Technical data, 117

E

- Electrical system
 - Technical data, 114
- Emergency on/off switch (kill switch), 17
 - Operating, 32
- Engine
 - Starting, 44
 - Technical data, 109
- Engine oil
 - Check fill level, 68
 - Fill location, 11
 - Oil dipstick, 11
 - Technical data, 110
 - Topping up, 70
- Engine speed warning, 48
 - Warning lamp, 15
- Equipment, 6

F

- Fairing
 - Installing center section, 97
 - Installing left side panel, 99
 - Installing right side panel, 98
 - Removing center section, 96
 - Removing left side panel, 98
 - Removing right side panel, 97
- Frame
 - Technical data, 116
- Front wheel stand
 - Mounting, 82
- Fuel
 - Fill location, 13
 - Refueling, 50
 - Technical data, 110
- Fuel reserve
 - Milage covered, 22
 - Warning indicator, 24
- Fuses
 - Position on motorcycle, 14
 - Replacing, 84
 - Technical data, 115

H

- Hazard warning flashers
 - Control, 18
 - Operating, 31
- Headlight
 - Headlight range, 38
 - Headlight range adjustment, 38
 - RHD/LHD traffic, 37
- Heated handlebar grips
 - Control, 18
 - Operating, 32
- Horn, 16

I

- Ignition
 - Switching off, 28
 - Switching on, 28
- Indicator lights, 15
 - Overview, 21
- Instrument cluster
 - Overview, 15

J

- Jump-starting, 92

K

Keys, 28

L

Lights

Control, 16

Headlight low beam, 30

Operating headlight flasher, 31

Operating headlight high beams, 31

Parking lights, 30

Switching on parking lights, 28

Lowered suspension

Limitations, 42

Luggage

Loading information, 42

M

Maintenance

General instructions, 68

Maintenance intervals, 121

Mirrors

Adjusting, 35

Mobility Services, 121

Motorcycle

Care, 101

Cleaning, 101

Parking, 50

Returning to use, 104

Storage, 104

Tying down, 52

Multifunction display, 15

Control, 15

Overview, 20

Selecting display readings, 30

Multifunction switch

General view, left, 16

General view, right, 17

N

Notice concerning current status, 7

O

Odometer

Control, 15

Resetting, 30

Offroad riding, 48

Onboard power socket

Information on use, 60

Position on motorcycle, 11

Onboard tool kit

Contents, 68

Position on motorcycle, 14

Overview of warning indicators, 23

Overviews

Auxiliary switch, 18

Instrument cluster, 15

Left side of motorcycle, 11

Left-hand multifunction switch, 16

Multifunction display, 20

Right side of motorcycle, 13

Right-hand multifunction switch, 17

Underneath seat, 14

Warning and indicator lamps, 21

P

Pre-Ride-Check, 46

R

- Rear-wheel drive
 - Technical data, 112
- Refueling, 50
- Rider's Manual (US Model)
 - Position on motorcycle, 14

S

- Safety instructions
 - About brakes, 49
 - On riding, 42
- Seat
 - Installing, 38
 - Locking device, 11
 - Removing, 38
- Service, 121
 - Reporting safety defects, 120
- Spark plugs
 - Technical data, 114
- Speedometer, 15
- Spring preload
 - Adjusting, 35
 - Adjustment element, 13
- Starting, 44
 - Control, 17

- Steering lock
 - Locking, 29
- Storage compartment
 - Installing, 40
 - Removing, 40
- Suspension
 - Technical data, 112
- Switching off, 50

T

- Tachometer, 20
- Technical data
 - Battery, 114
 - Brakes, 113
 - Clutch, 111
 - Dimensions, 117
 - Electrical system, 114
 - Engine, 109
 - Engine oil, 110
 - Frame, 116
 - Fuel, 110
 - Lights, 115
 - Rear-wheel drive, 112
 - Spark plugs, 114
 - Standards, 7

- Suspension, 112
- Tires, 113
- Transmission, 111
- Weights, 118
- Wheels, 113

Tires

- Checking tire inflation pressures, 37
- Checking tire tread depth, 77
- Inflation pressure table, 11, 14
- Inflation pressures, 114
- Recommendations, 78
- Running in, 47
- Technical data, 113
- Topcase
 - Operating, 64
- Torques, 107
- Transmission
 - Technical data, 111
- Troubleshooting chart, 106
- Turn indicators
 - Control, 16
 - Operating, 31
- Type plate
 - Position on motorcycle, 13

V

- Vehicle identification number
 - Position on motorcycle, 13

W

- Warning lamps, 15
 - ABS, 24
 - Coolant temperature, 24
 - Display, 22
 - Fuel reserve, 24
 - Overview, 21
- Weights
 - Payload table, 14
 - Technical data, 118
- Wheels
 - Checking spokes, 77
 - Installing front wheel, 79
 - Removing front wheel, 78
 - Size change, 78
 - Technical data, 113

The descriptions and illustrations in this manual may vary from your own motorcycle's actual equipment, depending upon its equipment level and accessories as well as your specific national version. No claims stemming from these differences can be recognized.

Dimensions, weights, fuel consumption and performance data are quoted to the customary tolerances.

The right to modify designs, equipment and accessories is reserved.

Errors and omissions excepted.

© 2014 Bayerische Motoren Werke Aktiengesellschaft
80788 Munich, Germany
Reprints and duplication of this work, in whole or part, are prohibited without the express written approval of BMW Motorrad, Aftersales.

Original Rider's Manual, printed in Germany.

