

## *Gas-Fired Indoor Duct Furnace Gravity and Power Vented*

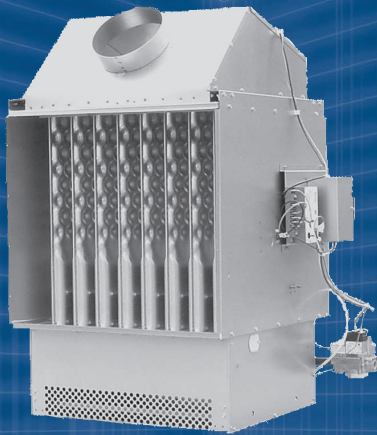

**MODEL DFG**

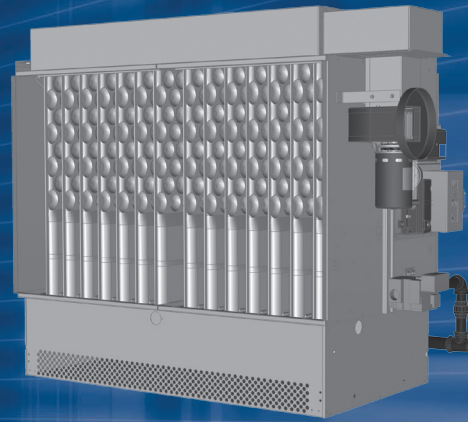

**MODEL DFP**

Modine offers a complete line of indoor heating equipment. This catalog describes in detail the gas-fired, gravity and power vented, indoor duct furnace units.

Included are product design benefits, construction features, performance data, unit selection procedure, control applications, and the optional and accessory devices available.

## Table of Contents

	Page
Features and Benefits .....	3
Indoor Duct Furnace Design Features .....	4
Performance Data .....	5
Unit Selection .....	6
Duct Furnace Pressure Drop Curves .....	7
Model Nomenclature Description .....	8-9
Options .....	10-11
Thermostats .....	12
Accessories / Amp Draw .....	13
Unit Dimensions - Gravity Vented Model DFG.....	14
Unit Dimensions - Power Vented Model DFP .....	15
Specifications .....	16-18
Model Nomenclature .....	19

### **WARNING**

Do not locate ANY gas-fired unit in areas where chlorinated, halogenated or acid vapors are present in the atmosphere.

### **WARNING**

Do not install in potentially explosive or flammable atmosphere laden with dust, sawdust, or similar airborne materials.

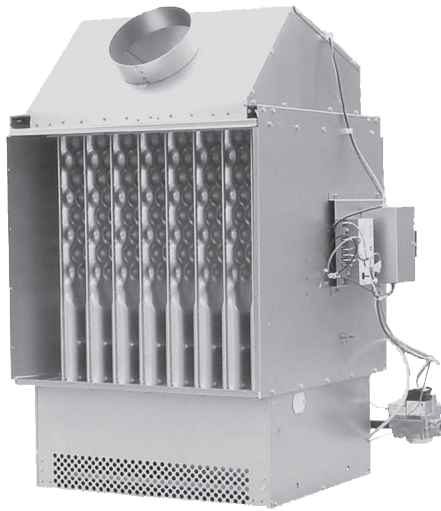

MODEL DFG

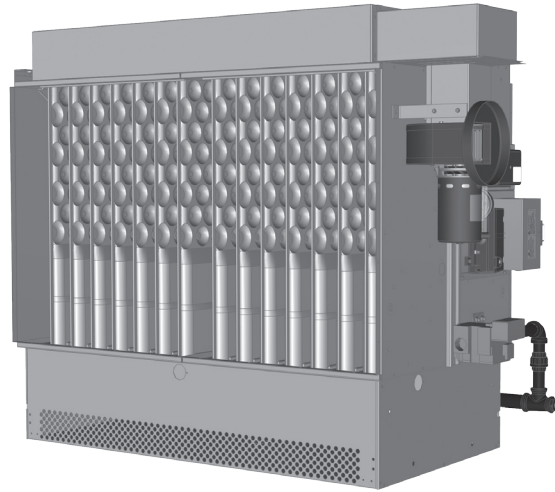

MODEL DFP

Table 3.1 - Standard Features and Factory Options

	Feature	Model	
		DFG	DFP
<b>Cabinet</b>	Aluminized steel cabinet (gauge indicated)	20 ga.	20 ga.
	4-point mounting with threaded rod (by others)	•	•
	Aluminized steel condensation drain pan ( <i>409 stainless steel optional</i> )	•	•
	Duct flanges for easy ductwork connection	•	•
<b>Heat Exchanger and Burner</b>	80% minimum thermal efficiency over 20° to 100°F temperature rise range for fuel savings in 11 sizes ranging from 75 to 400MBH	•	•
	Patented aluminized steel dimple tube clam-shell heat exchanger for maximum heat transfer ( <i>409 stainless steel optional</i> )	20 ga.	20 ga.
	Heat exchanger certified to withstand 3.0" W.C. external static for use in systems with long duct runs or high static accessories	•	•
	Aluminized steel burner with stainless steel separator strip ( <i>409 stainless steel optional</i> )	•	•
<b>Controls</b>	CSA certification for commercial and industrial use in the US and Canada	•	
	ETL certification for commercial and industrial use in the US and Canada		•
	Right hand control access when looking into the discharge ( <i>left hand optional</i> )	•	•
	Gravity vented with 45° angled round vent connection for tighter ducting	•	
	Field installed power exhauster accessory for horizontal venting or venting in buildings with negative pressure	•	
	Factory-installed power exhauster		•
	Controls for natural gas ( <i>propane optional</i> )	•	•
	Single stage gas controls ( <i>two stage, mechanical and electronic modulation, or building management controls optional</i> )	•	•
	Automatic reset high limit safety control ( <i>manual reset optional</i> )	•	•
	Blocked vent safety switch to verify proper venting	•	
	Differential pressure switch for proof of venting		•
	Intermittent pilot ignition with continuous retry control system	•	•
	Control terminal board and low voltage terminal connections	•	•
	Gas control step down transformer with 24V gas controls	•	•
Many options/accessories such as fan delay relay, smoke detector, timed freeze protection, mild temperature thermostat, airflow proving switch, room and duct stats, etc.	•	•	

## Gravity Vented (DFG) and Power Vented (DFP)

The indoor duct furnace was designed for use with a building's heating, heating/cooling, and make-up air systems. Available in 11 model sizes, the unit covers a wide variety of applications. They have input ranges from 75,000 to 400,000 Btu/Hr and can operate on either natural or propane gas. The airflow direction can be specified when ordering the unit. The duct furnace is certified for location either upstream or downstream from cooling coils and has a drain pan that allows connection to a condensate drain line.

**Figure 4.1 - Indoor Gravity Vented Duct Furnace**

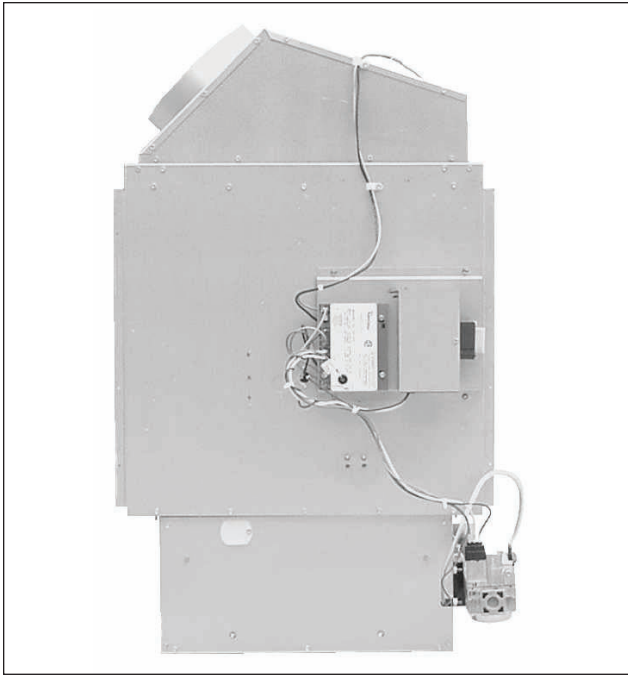

**Figure 4.2 - Indoor Power Vented Duct Furnace**

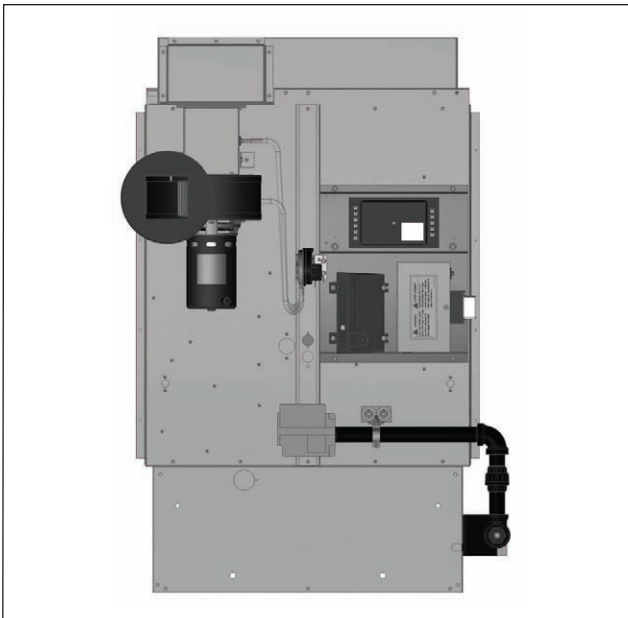

### Standard Features:

- CSA certification for use in the US and Canada (model DFG)
- ETL certification for use in the US and Canada (model DFP)
- 80% thermally efficient
- Blocked vent safety switch (model DFG only)
- Factory installed power venter with differential pressure switch for proving proper venting (model DFP only)
- 20 gauge aluminized steel cabinet
- 115V control step down transformer with 24V gas controls
- Aluminized steel heat exchanger
- Aluminized steel burner with stainless steel separator strip
- Certified to 3.0" W.C. external static pressure
- Single stage intermittent pilot with continuous retry control system for operation on natural gas or propane gas.
- Right side access to burner and gas controls (when looking into the discharge) with slide-out burner drawer
- High limit safety control
- Control terminal board

### Optional Features - Factory Installed

- 409 stainless steel heat exchanger and burner
- 409 stainless steel drip pan
- Two-stage, mechanical modulation, and/or electronic modulation controls for either natural or propane gas
- Building management compatible gas controls for modulation control using a 0-10 Vdc or 4-20 mA input
- Multiple furnace electronic amplifier for controlling up to 4 duct furnaces with one discharge air sensor
- Gas control step down transformers for 208/230V/1Ph and 208/230/460/575V supply voltages
- Left side access to burner and gas controls
- Adjustable differential air flow proving system
- Fan delay timer
- High and/or low gas pressure switches
- Manual reset high limit switch
- Timed freeze protection
- Supply air fire stat
- Control relay - double pole, double throw
- Installed thermostat - two-stage
- Separate line voltage and low voltage terminal strips
- Premium control box and gas control string

### Accessories - Field Installed

- Power exhauster with vent adapter (model DFG only)
- Electronic programmable heat/cool room thermostats—for single and two stage units
- Electronic two stage duct thermostats
- Electronic modulating room and duct thermostats and a room override for the duct thermostat
- Smoke detector
- 7-day digital and 7-day econo time clocks
- Summer/winter switch
- Condensate connection drain kits
- Pipe hanger adapter kits

### Special Applications

A 409 stainless steel heat exchanger and burner is recommended when the unit is installed downstream of a cooling coil or evaporative cooler, and when the combined entering/return air to the unit is below 40°F.

Table 5.1 - Air Temperature Rise - Gravity and Power Vented Indoor Duct Furnaces ① ②

Model Size	Btu/Hr		Air Temperature Rise Through Unit (°F)											
			20 ③	40 ③	50 ③	60	65	70	75	80	85	90	95	100 ④
	Input	Output	Max	CFM										
75	75,000	60,000	2778	1389	1111	926	855	794	741	694	654	617	585	556
100	100,000	80,000	3704	1852	1481	1235	1140	1058	988	926	871	823	780	741
125	125,000	100,000	4630	2315	1852	1543	1425	1323	1235	1157	1089	1029	975	926
150	150,000	120,000	5556	2778	2222	1852	1709	1587	1481	1389	1307	1235	1170	1111
175	175,000	140,000	6481	3241	2593	2160	1994	1852	1728	1620	1525	1440	1365	1296
200	200,000	160,000	7407	3704	2963	2469	2279	2116	1975	1852	1743	1646	1559	1481
225	225,000	180,000	8333	4167	3333	2778	2564	2381	2222	2083	1961	1852	1754	1667
250	250,000	200,000	9259	4630	3704	3086	2849	2646	2469	2315	2179	2058	1949	1852
300	300,000	240,000	11111	5556	4444	3704	3419	3175	2963	2778	2614	2469	2339	2222
350	350,000	280,000	11111⑤	6481	5185	4321	3989	3704	3457	3241	3050	2881	2729	2593
400	400,000	320,000	11111⑤	7407	5926	4938	4558	4233	3951	3704	3486	3292	3119	2963

- ① Ratings are shown for elevations up to 2000 feet. For higher elevations, the input rating should be reduced at the rate of 4% per 1000 feet elevation above sea level. For Canada, in elevations between 2000 and 4500 feet, the unit must be derated to 90% of the rating listed above.
- ② Units approved for use in California by CEC.
- ③ Units are supplied with a factory installed air baffle. For applications where an air temperature rise less than 60°F is desired, it is recommended to remove this baffle to reduce system pressure drop.
- ④ For Variable Air Movement Applications, see below.
- ⑤ For units with baffle the maximum CFM for the 350 and 400 results in a 23°F and a 27°F air temperature rise (respectively) based on the maximum unit pressure drop. For units without baffle, the maximum CFM for the 350 and 400 is 12963 and 14815 respectively resulting in a 20° ATR.

### Air Temperature and External Static Pressure Limits

The maximum allowable discharge air temperature is 150°F and the maximum allowable air temperature rise is 100°F. All duct furnaces are designed for a maximum allowable static pressure of 3.0" W.C. on the heat exchanger.

### Variable Air Movement Applications

When the air mover supplied by others can provide variable air movement (i.e. 2-speed or variable frequency drive units), the certified allowable minimum CFM of the duct furnace can be 66% of the minimum listed CFM in Table 5.1 if the unit is applied as follows:

1. The unit is provided with two-stage, mechanical modulation, or electronic modulation gas controls.
2. The unit is provided with a factory installed discharge air controller.
3. The system does not include a room thermostat.

The factory installed discharge air thermostat will prevent the unit from firing above the allowable 100°F rise when the unit is at or above the minimum CFM by monitoring the discharge air and going to low fire. A room thermostat cannot be used, because it is located remote from the unit, and could cause the unit to over-fire.

Figure 5.1 - Recommended Unit Configurations

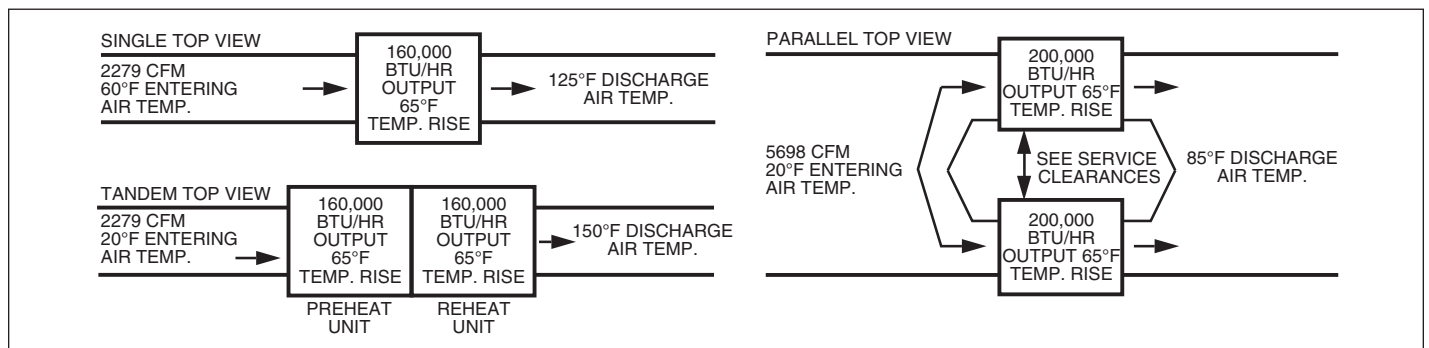

## CAUTION

Do not provide less than the minimum CFM throughput shown in Table 5.1 unless the unit meets Variable Air Movement Applications conditions.

### Selecting Model Size

To select the proper size indoor duct furnace, two of the following three pieces of information must be given.

#### Either:

1. The required Btu/Hr output.
2. The required CFM.
3. The required  $\Delta T$  ( $^{\circ}F$ )

The formula in step 3B will calculate the third item.

#### Then use the following procedure:

1. Determine the required Btu/Hr output.
2. Determine the Btu/Hr input required based on the outputs shown in Table 5.1.
3. Determine the required air temperature rise through the duct furnace. The temperature rise is determined by either of the following methods:
  - A. Using Table 5.1 - Air Temperature Rise find the model number of the unit with the required output Btu/Hr. Follow the row until the air volume (CFM) is found. Then proceed up the column to locate the corresponding temperature rise.
  - B. Using the algebraic formula:
 
$$\Delta T (^{\circ}F) = \frac{\text{Btu/Hr output}}{\text{CFM} \times 1.08}$$
4. Determine if the unit requires the use of a baffle in the field. The baffle may be removed if the ATR is between  $20^{\circ}$ - $60^{\circ}F$ . High temperature rise units require the baffle when the temperature rise is between  $60^{\circ}$ - $100^{\circ}F$ .

#### **For Variable Air Movement Applications:**

The determination of whether the unit should use a baffle should be based on the low speed temperature rise of the unit. Thus, if the high speed air temperature rise is  $40^{\circ}F$  and the low speed air temperature rise is  $80^{\circ}F$ , the baffle should not be removed.

### Determining Duct Furnace Pressure Drop

To determine the duct furnace pressure drop, use the following procedure:

5. Based on the style (with or without the baffle) of unit, determine which pressure drop curve should be used. Figure 7.1 for baffle removed and Figure 7.2 for baffled.
6. Enter either figure at the required CFM and follow up the curves until the CFM intersects with the curve for the duct furnace Btu/Hr input that was selected. Move horizontally across to the left and read the pressure drop.

### Selection Example

#### Given:

1. Btu/Hr output = 280,000 Btu/Hr
2. Temperature Rise =  $75^{\circ}F$

#### Selection:

1. The required Btu/Hr output = 240,000 Btu/hr.
2. From Table 5.1, the DFG350 (or DFP) has an  
Input = 350,000 Btu/hr  
Output = 280,000 Btu/Hr
3. The required temperature rise is  $75^{\circ}F$ . Using Table 5.1 for a  $75^{\circ}F$  air temperature rise, the CFM can be found to be 3457. Also, the CFM can be calculated by using the equation:

$$\text{CFM} = \frac{\text{Btu/Hr output}}{\Delta T (^{\circ}F) \times 1.08} \quad \text{or} \quad \frac{240,000}{75 \times 1.08} = 3419$$

4. Since the  $75^{\circ}F$  air temperature rise is between  $60^{\circ}$ - $100^{\circ}F$ , the unit would require the baffle.
5. To determine the pressure drop, use Figure 7.2 for units with baffle.
6. Enter the bottom of the table at 3457 CFM until it intersects the model size 350 curve. Then move horizontally across to the left and read the pressure drop of 0.26" W.C.

**Figure 7.1 - Duct Furnace Without Baffle Pressure Drop vs CFM Curves**

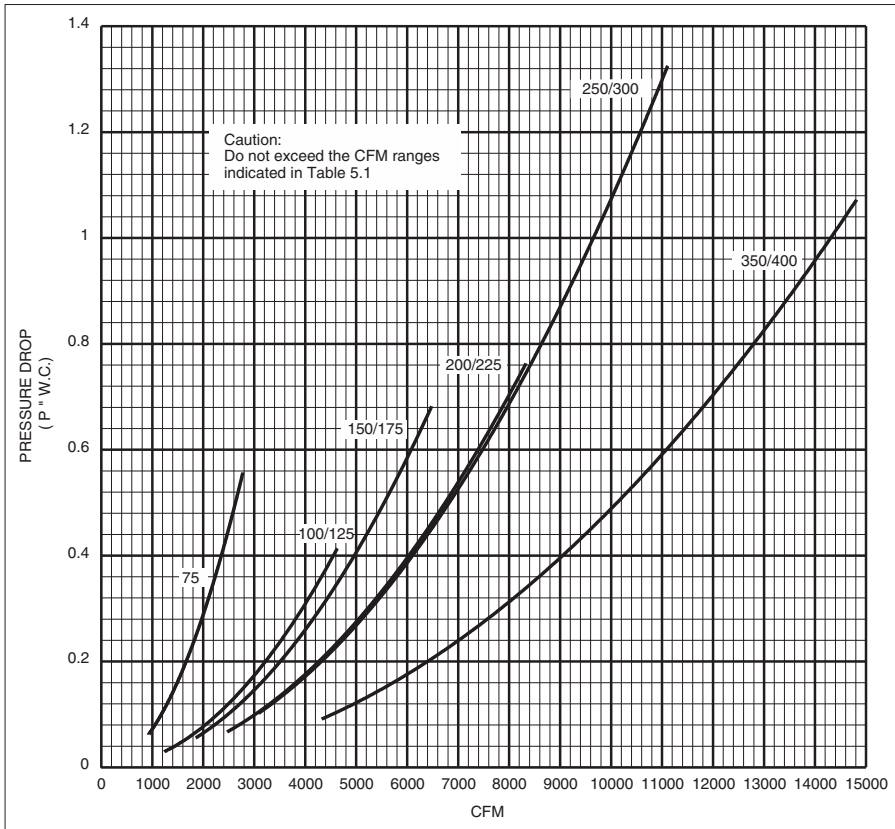

**Figure 7.2 - Duct Furnace With Baffle Pressure Drop vs CFM Curves**

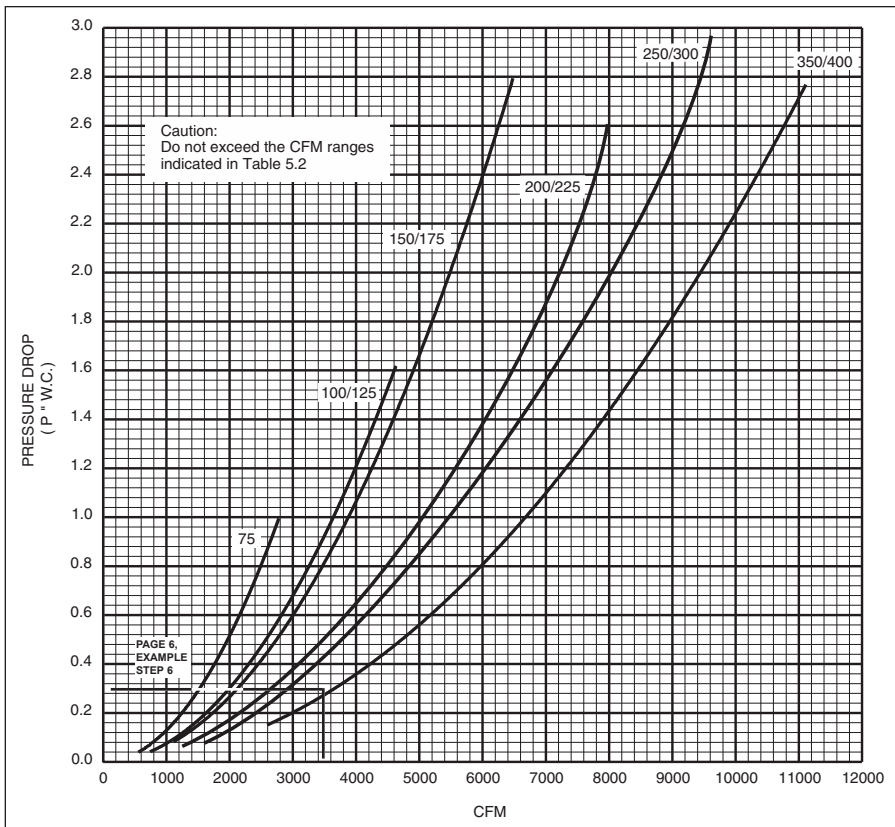

## Model Digit Descriptions

Once the first six digits of the model number have been determined, pages 9 through 11 detail the specification of the additional model number digits. For the complete model nomenclature description see page 19.

### Digit 7

#### Heat Exchanger/Burner/Drip Pan Material (HE)

Specifies the material for the heat exchanger, burner, and drip pan material. A 409 stainless steel heat exchanger and burner is recommended when the unit is installed downstream of a cooling coil or evaporative cooler, and when combined entering/return air to the unit is below 40°F.

A = Aluminized steel heat exchanger, burner, and drip pan

S = 409 Stainless steel heat exchanger and burner and an aluminized steel drain pan

T = 409 Stainless steel heat exchanger, burner and drain pan

### Digit 8

#### Development Sequence (DS)

Used for internal factory purposes to indicate the style of controls used on the unit.

F = Single stage gas controls

M = Two stage, mechanical, or electronic modulating

### Digit 9

#### Access Side (AS)

Determines the side of the unit on which the controls are accessed. The control side is determined by looking in the discharge of the unit (air blowing at you) and then specifying the access side (right or left hand). Includes access to gas controls, electrical control wiring, and the discharge side of the unit for any optionally mounted discharge air components.

R = Right Hand

L = Left Hand

### Digit 10

#### Air Temperature Rise (ATR)

Indicates the temperature range of the duct furnace.

All Units are factory supplied with an air distribution baffle to direct the air toward the bottom of the heat exchanger where the heat exchanger tubes are the warmest. The baffle is required because of the low air volume (CFM) that is going through the duct furnace. This applies to units having an air temperature rise from 60 to 100°F. If the application will be operating with an air temperature rise less than 60°F it is recommended that the baffle be removed in the field to reduce pressure drop through the unit. Select N for this digit.

### Digit 11

#### Gas Type (GT)

Determines the type of gas that will be used with the unit and the style of ignition controller. The type of gas determines the orifices used on the unit. The orifices are sized for elevations up to 2000 feet. For United States elevations of 2000 feet or greater, specify this at the time of ordering and the unit will be derated 4% per 1000 feet of elevation. In Canada for elevations of 2000 to 4500 feet, the unit is derated 10%.

N = Natural gas with continuous retry ignition controller

A 100% shut-off with continuous retry ignition controller is used. On a call for heat, the system will attempt to light the pilot for 70 seconds. If the pilot is not sensed for any

reason, the ignition control will wait for approximately six minutes with the combination gas control closed and no spark. After six minutes, the cycle will begin again. After three cycles, some ignition controllers lockout for approximately one hour before the cycle begins again. This will continue indefinitely until the pilot flame is sensed or power is interrupted to the system.

P = Propane gas with continuous retry ignition controller

A 100% shut-off with continuous retry ignition controller is used. On a call for heat, the system will attempt to light the pilot for 70 seconds. If the pilot is not sensed for any reason, the ignition control will wait for approximately six minutes with the combination gas control closed and no spark. After six minutes, the cycle will begin again. After three cycles, some ignition controllers lockout for approximately one hour before the cycle begins again. This will continue indefinitely until the pilot flame is sensed or power is interrupted to the system.

### Digit 12

#### Gas Valve (GV)

Determines the type of gas valve provided with the unit.

1 = Single-stage

Single-stage gas controls utilize a single-stage combination gas control, a single-stage low voltage thermostat, and an ignition control. The unit fires at 100% full fire based on a call for heat from a room thermostat (thermostat ordered separately).

2 = Two-stage

Two-stage gas controls utilize a two-stage combination gas control, a two-stage low voltage thermostat, and an ignition control. The unit fires at 50% fire on low stage or 100% fire on high stage of the unit based on the call for heat from either a room or duct thermostat (thermostat ordered separately).

3 = Mechanical modulation (Natural Gas Only)

Mechanical modulation gas controls utilize a mechanical modulating gas control and an ignition control. The system is designed primarily for use in constant blower (make-up air) applications. The discharge air temperature is maintained by setting the non-electric control dial of the modulating gas valve in one of ten positions ranging from Lo to Hi. A hydrostatic sensing bulb that is mechanically attached to the modulating gas valve is factory installed in the discharge air stream and modulates the gas flow. Modulation occurs between 40% through 100% full fire. When the discharge air hydrostatic sensing bulb is satisfied, the modulating valve closes completely. The hydrostatic sensing bulb is included with the system. Because this control is non-electric, it cannot be used with a room override thermostat.

4 = Electronic Modulation

Electronic modulation gas controls utilize an electronic modulating/regulating gas control, combination gas valve, an ignition control, modulating amplifier and either a modulating room thermostat or modulating duct thermostat with remote temperature set point adjuster. The thermostat can modulate the gas flow between 40% through 100% full fire. Requires the addition of either the room or duct electronic modulating thermostat.

When the duct thermostat is utilized, a room override thermostat can be added. When calling for heat, the room override thermostat provides full fire operation until the space temperature is satisfied. Control is then returned to



the duct sensing control. In this situation, either the duct thermostat or the room override thermostat can call for heat.

### 5 = *Electronic Modulation - Master*

Used in higher Btu/hr input applications where more than one duct furnace is being used with electronic modulating gas controls. Allows one duct sensing thermostat to control the firing rate of the Master duct furnace and up to three Slave duct furnaces (See 6 = Slave). Utilizes the same controls as described in 4 = Electronic Modulation, except that a single duct furnace amplifier is replaced by a multiple furnace amplifier. The multiple furnace amplifier sends a signal to all of the gas valves so that they modulate at the same percentage. When the thermostat is satisfied, the amplifier cuts power to the combination gas valves of the Master unit and all Slave units which prevents gas flow to both the main and pilot burners.

### 6 = *Electronic Modulation - Slave*

Requires one Master unit. The Slave furnace includes an electronic modulating/regulating gas control, combination gas valve, and an ignition control, but no modulating amplifier and does not require a discharge air thermostat. The modulating gas valve receives the modulation percentage from the Master duct furnace. Up to three Slave duct furnaces can be connected to one Master unit.

### 7 = *Electronic Modulation - 0-10 Vdc External Input*

Allows for control of the duct furnace firing rate by a Building Management System (BMS). Utilizes an electronic modulating/regulating gas control, combination gas valve, an ignition control, modulating signal conditioner, and an inverted (0 Vdc being high fire and 10 Vdc being low fire) 0-10 Vdc input signal provided by a BMS. The signal conditioner can modulate the gas flow between 40% and 100% full fire. When the BMS thermostat (supplied by others) is satisfied, the BMS heat contact (supplied by others) opens to cut power to the combination gas valve which prevents gas flow to both the main and pilot burners.

### 8 = *Electronic Modulation - 4-20 mA External Input*

Allows for control of the duct furnace firing rate by a Building Management System (BMS). Utilizes an electronic modulating/regulating gas control, combination gas valve, an ignition control, modulating signal conditioner, and an inverted 4-20 mA input signal provided by a BMS (4 mA being high fire and 20 mA being low fire). The signal conditioner can modulate the gas flow between 40% and 100% full fire. When the BMS thermostat (supplied by others) is satisfied, the BMS heat contact (supplied by others) opens to cut power to the combination gas valve which prevents gas flow to both the main and pilot burners.

## Digit 13

### Additional Safety Switches (SS)

Provides additional gas train safety devices.

A low gas pressure switch monitors the gas supply pressure ahead of all the gas controls and shuts off the electric supply to the ignition controller and combination gas valve if low gas pressure is experienced. This will shut off all gas flow to the burner. If the gas pressure to the unit is below the normal operating pressure, the burner could have difficulty lighting properly. The switch has an automatic reset so that if the gas pressure is interrupted and then returned to the allowable range, the switch will automatically allow the unit to operate.

A high gas pressure switch monitors the gas supply pressure downstream of all the gas controls and shuts off the electric supply to the ignition controller and combination gas valve if high gas pressure is experienced. This will shut off all gas flow to the burner. If the gas pressure to the unit is too high, the gas controls could be damaged and cause the unit to over fire. The switch has a manual reset so that a service person must check that none of the gas controls have been damaged, and then reset the switch to allow the unit to operate when the gas conditions are returned to the allowable range of the pressure switch.

If no additional safety switches are ordered a standard control box may be selected.

- 4 = No Additional Safety Switches (Standard Control Box)
- 0 = No Additional Safety Switches (Premium Control Box)
- 1 = Low Gas Pressure Switch (Premium Control Box)
- 2 = High Gas Pressure Switch (Premium Control Box)
- 3 = High and Low Gas Pressure Switches (Premium Control Box)

## Digit 14

### Supply Voltage (SV)

Indicates the supply voltage for the unit. For duct furnace units, this specifies the line voltage to 24V control transformer that will be provided with the unit.

- A = 115V/60Hz/1Ph
- B = 208V/60Hz/1Ph
- C = 230V/60Hz/1Ph
- D = 208V/60Hz/3Ph
- E = 230V/60Hz/3Ph
- F = 460V/60Hz/3Ph
- G = 575V/60Hz/3Ph

## Digit 15

### Transformer (TR)

Indicates the size of the step-down transformer that converts line voltage power to low voltage for use with the gas controls. The transformer size is rated in volt-amperes (VA). 40 VA transformers are Class II with integral fusing. 75 VA transformers are Class II with a 3.2A circuit breaker. 150 VA and 250 VA transformers include separate primary fusing. The size of the transformer should be specified based on Table 11.1.

- 1 = 40 VA
- 2 = 75 VA
- 3 = 150 VA
- 4 = 250 VA
- 0 = None

**Table 9.1 - Gas Control Transformer Sizing**

Unit Type	Controlling	Digit 15
Non Master Duct Furnace		1
Master Duct Furnace	1 Slave ①	2
Master Duct Furnace	2 Slaves ②	3
Master Duct Furnace	3 Slaves ②	3
Slave Duct Furnace		0

① Digit 13 must equal 0,1,2, or 3

② When Digit 14 = F or G, Digit 13 must equal 0,1,2, or 3

Figure 10.1 - Factory Mounted Option Locations

**Indoor Gravity Vented Duct Furnace**

1. Discharge Thermostat
2. Low Gas Pressure Switch
3. High Gas Pressure Switch
5. Timed Freeze Protection
6. Ignition Controller
8. Control Relay
9. Time Delay Relay
10. Furnace Low Voltage Terminal Strip
12. Furnace Supply Power Terminal Strip
13. Control Step Down Transformer
46. Electronic Modulating Amplifier
47. Electronic Modulating Gas Valve
48. Air Flow Proving Switch
49. High Limit Switch
50. Supply Air Fire Stat
51. Main Gas Valve
52. Burner Box
56. Blocked Vent Safety Switch
57. Control Terminal Board

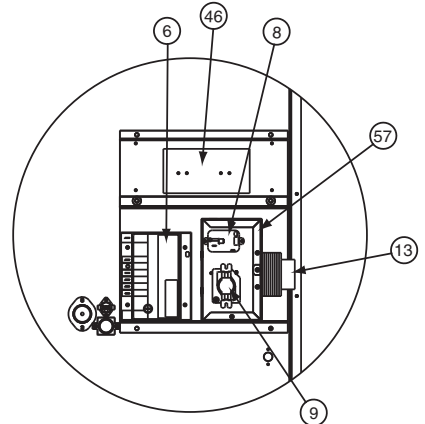
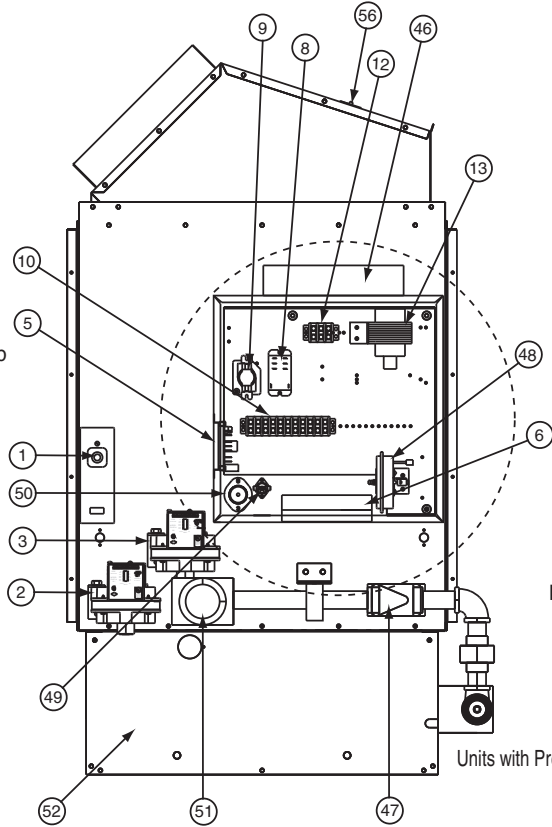

Units with Standard Control Box

**Note:** Wrap around gas train on premium and electronic modulation units only.

**Indoor Power Vented Duct Furnace**

1. Discharge Thermostat
2. Low Gas Pressure Switch
3. High Gas Pressure Switch
4. Power Exhauster
5. Timed Freeze Protection
6. Ignition Controller
8. Control Relay
9. Time Delay Relay
10. Furnace Low Voltage Terminal Strip
12. Furnace Supply Power Terminal Strip
13. Control Step Down Transformer
46. Electronic Modulating Amplifier
47. Electronic Modulating Gas Valve
48. Air Flow Proving Switch
49. High Limit Switch
50. Supply Air Fire Stat
51. Main Gas Valve
52. Burner Box
55. Differential Pressure Switch
57. Control Terminal Board

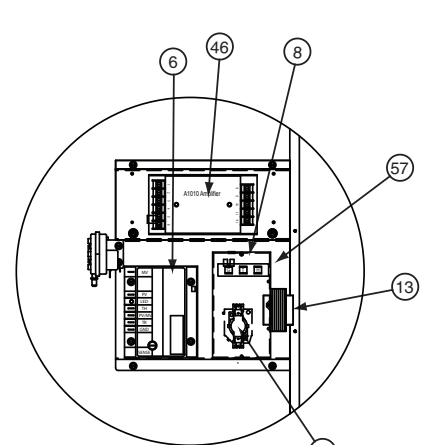
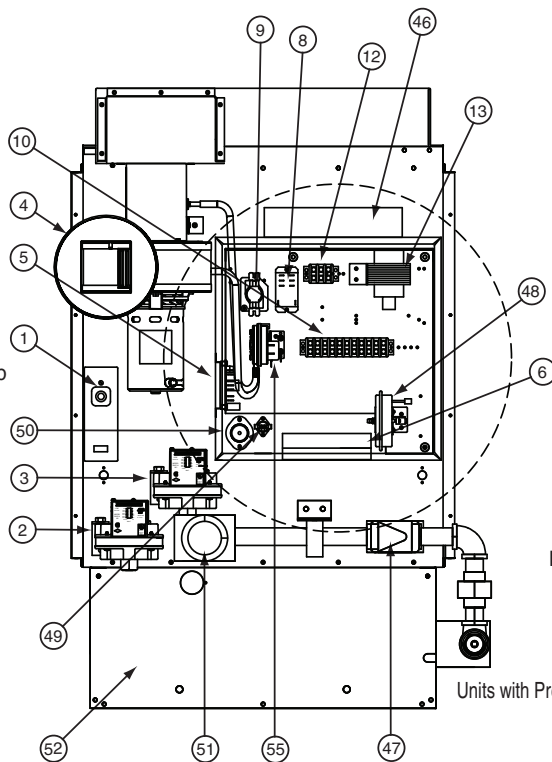

Units with Standard Control Panel

**Note:** Wrap around gas train on premium and electronic modulation units only.

The following list details the factory installed options available. For the location of all options, see Figure 10.1, as a premium control box (Digit 13=0 through 3) may be required.

### **Timed Freeze Protection (5)**

The timed freeze protection system is factory installed in the duct furnace electrical junction box with the sensor (30°F-75°F adjustable) factory installed in the discharge air stream. On initial start-up, the timed delay in the system allows the unit to go through the normal ignition sequence. The timed delay is an automatic reset switch and adjustable for 1-10 minutes. In the event that the unit fails to fire after this period, the discharge air sensor will sense the cold air and will shut down the entire unit.

### **Supply Air Fire Stat (50)**

The supply air fire stat is factory installed in the duct furnace electrical junction box with the sensor in the discharge air stream. In case of elevated temperatures (200°F) in the supply air, the manual reset switch shuts down the entire unit.

### **Control Relay (8)**

Includes a 24v relay coil with double-pole, double throw (DPDT) contacts for sequence of operation control switching. The two normally open and two normally closed contacts are rated with a maximum of 30 amps @ 115V/1Ph.

### **Manual Reset High Limit Switch (49)**

The manual reset high limit switch is factory installed in place of the standard automatic reset high limit switch located in the duct furnace electrical junction box. In case of a failure of the blower motor, blockage of the inlet air, etc., the manual reset switch prevents the unit from cycling on the high limit for a prolonged period of time. To prevent building freezing, this option is not recommended for heating units that are the only source of building heat.

### **Time Delay Relay (9)**

The time delay relay is factory installed in the duct furnace electrical junction box. The standard duct furnace is provided for instantaneous fan operation. On a call for heat, the blower is energized (control by others) at the same time as the gas controls. The optional time delay relay allows the gas controls to operate for approximately 30 seconds before the blower starts. This allows the heat exchanger a warm-up period so that the initial delivered air is not cool. The time delay relay also keeps the motor running for approximately 30 seconds after the call for heat has been satisfied to remove the residual heat from the heat exchanger.

Factory and Field Installed

	Type	Installation	Description
<b>Single-stage Thermostats</b>	Room	Field	Honeywell T822D1008 - 1.0 amp @ 30 VAC; 55-95°F temperature range; heat anticipator 0.18 to 1.0 amp rating.
	Room	Field	Robertshaw CM-260 - 1.5 amp @ 30 VAC; 45-75°F temperature range; heat anticipator 0.18 to 1.0 amp rating.
	Sub-Base	Field	SB-3A-1 Sub-base for Robertshaw CM-260 thermostat - Sub-base switching: System auto/off, Fan - auto/on. (Requires Fan Delay Relay for duct furnaces.)
	Room - Programmable Figure 14.1	Field	Robertshaw SHC-7 7-day programmable thermostat. One heat and one cool stage; Fan On/Auto and Heat/Off/Cool/Auto System Switching; 2 to 4 events per day; Override feature.
<b>Two-stage Thermostats</b>	Room - Digital (With Switching)	Field	Honeywell TH5220D1029 digital non-programmable room stat with switching - range 40-90°F
	Room - Programmable Figure 14.1	Field	Robertshaw SHC-1 7-day programmable thermostat. Two heat and two cool stages; Fan On/Auto and Heat/Off/Cool/Auto System Switching; 2 to 4 events per day; Override feature; One auxiliary output terminal.
	Duct ①	Factory or Field	Honeywell T678A1015 - 0-100°F temperature range; 20 foot capillary; 8 amp rating @ 120V.
	Duct ①	Factory or Field	Honeywell T678A1361 - 55-175°F temperature range; 20 foot capillary; 8 amp rating @ 120V.
	Duct Figure 14.3	Factory	Johnson Controls Electronic Temp Control with factory installed SET189A-600R Temp Sensor. Shipped loose A350 temp selector and one S350 Stage Adder.
<b>Electronic Modulating Gas Control Thermostats</b>	Duct Figure 14.4	Field	Maxitrol Discharge Air Sensor TS121 and Mixing Tube MT2R-12. Range 55-90°F. <b>REQUIRES THE ADDITION OF THE SET POINT ADJUSTER - Maxitrol TD121 (See below).</b>
	Set Point Adjuster Figure 14.4	Field	FieldSet Point Adjuster - Maxitrol TD 121 (For use with Maxitrol Duct Sensing System).
	Room Override Figure 14.4	Field	Can only be used with Maxitrol Duct Sensing System described above. Includes Maxitrol T115 room override stat. Temperature range 40-90°F.
	Room - Figure 14.2	Field	Maxitrol Selectra-Stat T120. Temperature range 60-85°F.

① The thermostat is factory installed with sensing tube shipped on the side of the unit for field installation in the ductwork.

Figure 12.1  
7-Day Programmable Thermostat



Figure 12.2  
Maxitrol Selectra-stat



Figure 12.3  
System 350 Components



Figure 12.4  
Maxitrol Duct Sensing Components



**Field Installed**

**7-Day Electronic Programmable Time Clock**

7-day/24-hour digital programmable time clock that features 7-day power-outage carryover of program and time of day without the use of batteries. The control allows for simple and inexpensive control of functions such as automatic temperature setback (requires setback thermostat purchased separately), reduction of outside air during periods when the building is not occupied, and switching main supply fans from continuous to intermittent operation.

As a 24-hour control, the same ON/OFF program is utilized each day of the week, Saturday and/or Sunday, or any other day may be skipped. When schedules vary from day to day, the 7-day programming capability allows for a different schedule each day of the week, with up to 16 set points available. Requires a 115V/1Ph power supply by others.

**7-Day Econo-Timer**

The 7 day push pin style appliance timer allows for simple and inexpensive control of functions such as automatic temperature setback (requires setback thermostat purchased separately), reduction of outside air during periods when the building is not occupied, and switching main supply fans from continuous to intermittent operation. The time clock shall be mounted in a suitable enclosure (by others) complying with the requirements of all local codes and the NEC. The terminals of the time clock are line voltage so the base must be located in a NEMA 1 enclosure (by others). Requires 115V/1Ph power supply by others.

**Total Unit Amp Draw**

The control step down transformer amp draw includes ignition controllers, gas valves, control relays, and amplifiers.

This is the total unit amp draw for model DFG units. For Model DFP units, the amp draw of the power exhauster must also be added. See Table 13.2 for data.

**Table 13.1 - Control Step Down Transformer Amp Draws**

Digit 15 (Transformer)	Digit 14 (Supply Voltage)						
	A (115/60/1)	B (208/60/1)	C (230/60/1)	D (208/60/3)	E (230/60/3)	F (460/60/3)	G (575/60/3)
0	0	0	0	0	0	0	0
1	0.35	0.19	0.17	0.19	0.17	0.09	0.07
2	0.65	0.36	0.33	0.36	0.33	0.16	0.13
3	1.30	0.72	0.65	0.72	0.65	0.33	0.26
4	2.17	1.2	1.09	1.20	1.09	0.54	0.43

**Table 13.2 - Power Exhauster Motor Amp Draws (Power Vented Model DFP Only) ①**

Model Size	Digit 14 (Supply Voltage)						
	A (115/60/1)	B (208/60/1)	C (230/60/1)	D (208/60/3)	E (230/60/3)	F (460/60/3)	G (575/60/3)
75-175	1.40	0.70	0.60	0.70	0.60	0.30 ②	0.24 ②
200-400	2.40	1.40	1.30	1.40	1.30	0.65 ③	0.52 ③
500-800	4.80	2.80	2.60	2.80	2.60	1.30 ④	1.04 ④
840-960	7.20	4.20	3.90	4.20	3.90	1.95 ⑤	1.56 ⑤

① For Digits F (460V) and G (575V), amp draw shown is on primary (line) side of required step-down transformer.

② Requires a 250 VA transformer.

③ Requires a 500 VA transformer.

④ Requires a 750 VA transformer.

⑤ Requires a 1000 VA transformer.

Figure 14.1 - Indoor Gravity Vented Duct Furnace Dimensions

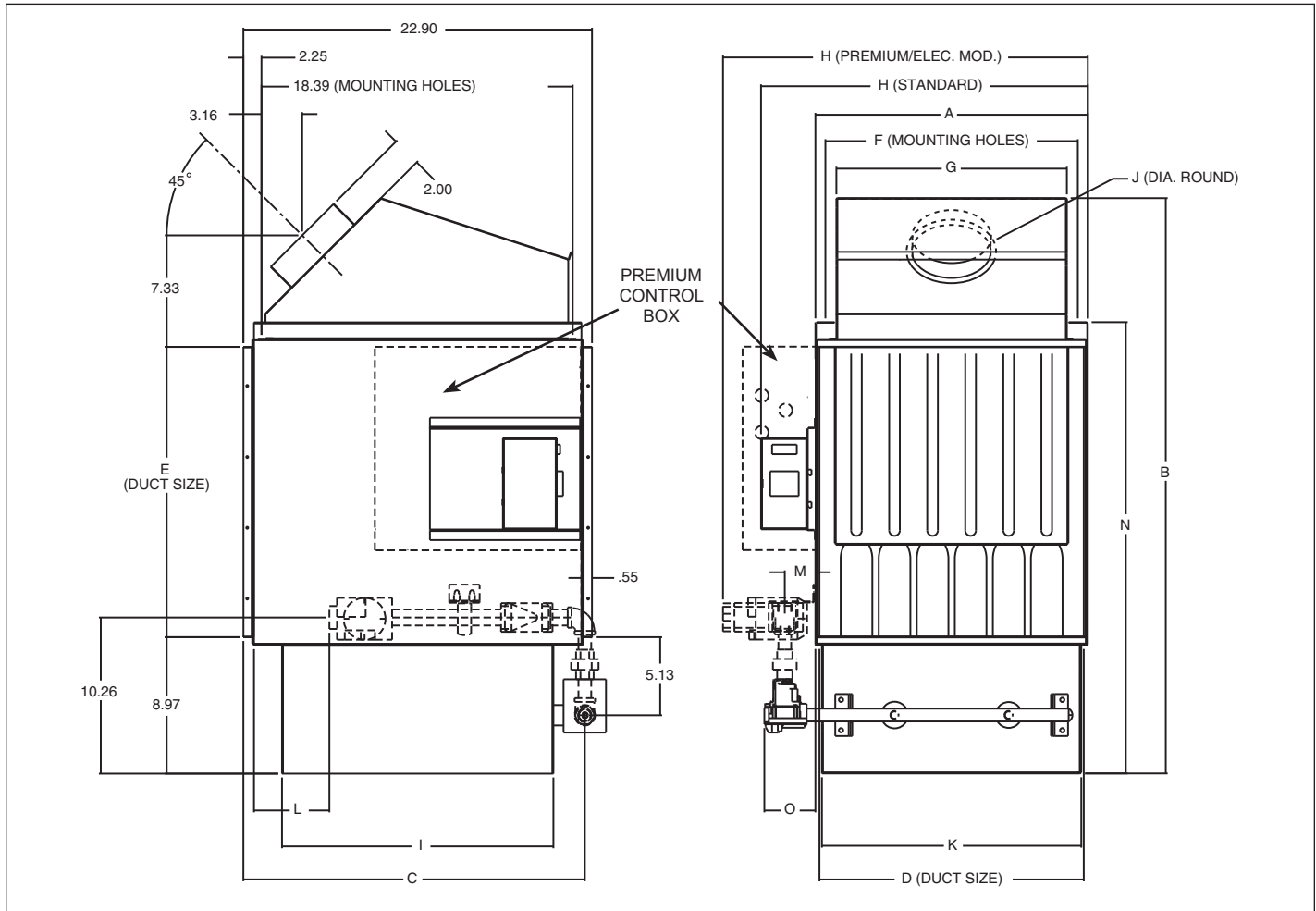

Table 14.1 - Indoor Gravity Vented Duct Furnace Dimensions

(All Dimensions in inches)		Model Size					
Dimensions		75	100/125	150/175	200/225	250/300	350/400
A		15.41	17.90	22.16	24.29	27.33	38.83
B		37.80	37.80	37.80	41.80	41.80	41.80
C (standard)		22.43	22.43	22.43	24.09	24.09	24.09
D		15.21	17.70	21.96	24.09	27.13	38.63
E		19.07	19.07	19.07	23.07	23.07	23.07
F		14.09	16.59	20.85	22.98	26.01	37.51
G		12.65	15.14	19.41	21.60	24.60	36.14
H (standard)		18.98	21.47	25.73	28.06	31.40	42.40
H (premium/elec. mod.)		21.48	23.97	28.24	30.30	33.31	44.84
I		17.83	17.83	17.83	20.68	20.68	20.68
J		5	6	7	7	8/10	10
K		14.55	17.04	21.31	23.26	26.44	37.80
L (min. approx.) (premium/elec. mod.)		5.0	5.0	5.0	6.6/6.1	6.1	6.1/5.8
M		2.01	2.01	2.01	1.94	1.94	1.94
N		29.65	29.65	29.65	33.65	33.65	33.65
O (max. approx.) (standard)		5.6	5.6	5.6	6.8/6.2	6.2	8.3/8.6
Gas Connection Pipe Size (max. std.)		1/2	1/2	1/2	1/2 / 3/4	3/4	3/4
Gas Connection Pipe Size (max. prem.)		3/4	3/4	3/4	3/4	3/4	3/4
Approx. Weight	Unit Shipping	89#	113#	140#	175#	213#	284#
	Unit Net	73#	95#	121#	155#	181#	251#

Figure 15.1 - Indoor Power Vented Duct Furnace Dimensions

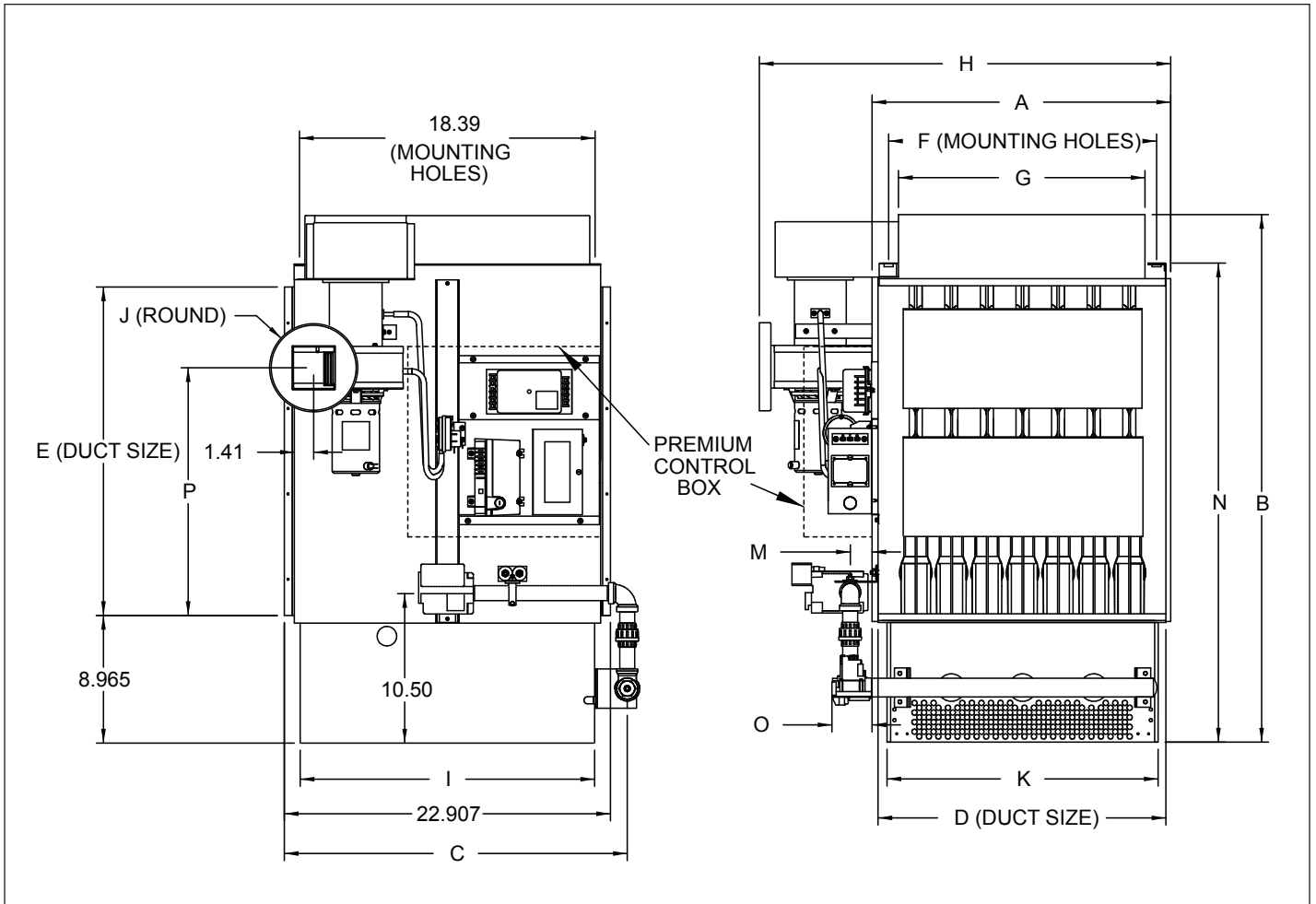

Table 15.1 - Indoor Power Vented Duct Furnace Dimensions

(All Dimensions in inches)		Model Size					
Dimensions		75	100/125	150/175	200/225	250/300	350/400
A		15.41	17.90	22.16	24.29	27.33	38.83
B		33.05	33.05	33.05	37.05	37.05	37.05
C (standard)		22.43	22.43	22.43	24.09	24.09	24.09
D		15.21	17.70	21.96	24.09	27.13	38.63
E		19.07	19.07	19.07	23.07	23.07	23.07
F		14.09	16.59	20.85	22.98	26.01	37.51
G		12.65	15.14	19.41	21.60	24.60	36.14
H		23.75	26.26	30.51	32.78	35.79	47.32
I		17.83	17.83	17.83	20.68	20.68	20.68
J		4	4	4	6	6	6
K		14.55	17.04	21.31	23.26	26.44	37.80
M		2.01	2.01	2.01	1.94	1.94	1.94
N		29.65	29.65	29.65	33.65	33.65	33.65
O (max. approx.) (standard)		5.6	5.6	5.6	6.8/6.2	6.2	8.3/8.6
P		14.03	14.03	14.03	17.40	17.40	17.40
Gas Connection Pipe Size (max. std.)		1/2	1/2	1/2	1/2 / 3/4	3/4	3/4
Gas Connection Pipe Size (max. prem.)		3/4	3/4	3/4	3/4	3/4	3/4
Approx. Weight	Unit Shipping	101#	125#	152#	187#	225#	296#
	Unit Net	85#	107#	133#	167#	193#	263#

## General

### A. Standards

- A.1. All model DFG units shall include C.S.A. (Canadian Standards Association) design certification for use in both the US and Canada to the ANSI Z83.8 - latest revision, standard for "Gas Unit Heater and Gas-Fired Duct Furnaces" for safe operation, construction, and performance.
- A.2. All model DFP units shall include E.T.L. design certification for use in both the US and Canada to the ANSI Z83.8 - latest revision, standard for "Gas Unit Heater and Gas-Fired Duct Furnaces" for safe operation, construction, and performance.

### B. Mechanical Configuration

*All unit(s) shall have right side (opt left side), when looking into the discharge, access to all controls/venting and include:*

Furnace section with 80% minimum efficiency provided by an indirect-fired heat exchanger with dimpled tube pattern for efficient heat transfer.

### C. Venting Arrangements

- C.1.a. The unit shall be gravity vented arrangement with a 45° angled round vent connection to allow for tighter installation to duct system components.
- C.1.b. The unit shall be power vented with side vent connection access.

### D. Indoor Unit Casing

The duct furnace unit casing shall be constructed of not less than 20 gauge aluminized steel.

### E. Furnace Section

- E.1. The heat exchanger shall be made of 20 gauge aluminized steel tubes and headers (opt) 20 gauge 409 stainless steel tubes and headers. The thermal efficiency of the unit shall be a minimum of 80% efficient for all air flow ranges. The restrictor shall be sized to maintain the unit efficiency of 80% in the temperature range of 20°F-60°F or 20°F-100°F. Each heat exchanger tube shall be individually and directly flame-fired. The heat exchanger tube shall be contoured and dimpled to provide efficient heat transfer and crimped to allow for thermal expansion and contraction. The flue collector box shall be made of 20 gauge aluminized steel.
- E.2. The heat exchanger seams and duct connections shall be certified to withstand 3.0" W.C. external static pressure without burner flame disturbance.
- E.3. The burner shall be made of the same material as the heat exchanger with a thickness of not less than 28 gauge. Burner shall have non-clogging, slotted ports with a stainless steel separator strip designed for good

lighting characteristics without noise of extinction for both natural and propane gas. The burner shall be located for service removal without disconnecting the main gas supply piping.

- E.4. The condensation shall be removed through openings in the bottom pan. The drain pan shall be constructed of 20 gauge aluminized steel. (opt) 409 stainless steel.
- E.5. The gas manifold piping shall allow for gas piping connection on the side of the unit for slab mounted units and through the unit bottom for suspended units. The manifold shall include a ground joint union for ease of servicing of the orifices without removing the burner assembly or main gas valve string.
- E.6. The orifices shall be provided on both natural and propane gas with adjustable air shutters for controlling the primary air mixture.
- E.7. The ignition controller shall be 100% shut-off with continuous retry for natural gas. (opt) The ignition controller shall be 100% shut-off with continuous retry for propane gas.
- E.8. The gas pressure shall be between 6-7" W.C for natural gas. (opt) The gas pressure shall be 11-14" W.C. for propane gas.
- E.9. The solid state ignition system shall intermittently light the pilot each time the system is energized. Once the pilot is proven, the main gas valve shall open and allow gas flow to the main burner.
- E.10. The unit gas controls shall be provided with the following:
- E.10.a. Single-stage gas controls with a single-stage combination gas control, an ignition control, and a single-stage low voltage thermostat. The unit fires at 100% full fire based on a call for heat from a room thermostat.
- E.10.b. (opt) Two-stage gas controls with a two-stage combination gas control, an ignition control, and a two-stage low voltage thermostat. The unit fires at 50% fire on low stage or 100% fire on high stage of the unit based on the call for heat from either a room or duct thermostat.
- E.10.c. (opt) Mechanical modulation gas controls with a mechanical modulating gas control and an ignition control. The discharge air temperature is maintained by setting the non-electric control dial of the modulating gas valve in one of ten positions ranging from Lo to Hi. A hydrostatic sensing bulb that is mechanically attached to the modulating gas valve is factory installed in the discharge air stream and modulates the gas flow. Modulation occurs between 40% through 100% full fire. When the discharge air hydrostatic sensing bulb is satisfied, the modulating valve closes completely. The hydrostatic sensing bulb is included with the system. Because this control is non-electric, it cannot be used with a room override thermostat.
- Available for use with Natural Gas only.



- E.10.d. (opt) Electronic modulation gas controls with an electronic modulating/regulating gas control, combination gas valve, an ignition control, modulating amplifier, and either a modulating room thermostat or modulating duct thermostat with remote temperature set point adjuster. The thermostat can modulate the gas flow between 40% through 100% full fire. The firing rate shall be controlled by a
- (opt) duct sensor with remote temperature adjuster.
  - (opt) duct sensor with remote temperature adjuster and room override thermostat.
  - (opt) room thermostat.
- E.10.e. (opt) Electronic Modulation Master gas controls with an electronic modulating/ regulating gas control, combination gas valve, an ignition control, modulating amplifier and either a modulating room thermostat or modulating duct thermostat with remote temperature set point adjuster. The thermostat can modulate the gas flow between 40% through 100% full fire. Allows one duct sensing thermostat to control the firing rate of the Master duct furnace and up to three Slave duct furnaces. The Master furnace sends a signal to all of the gas valves so that they modulate at the same percentage. When the thermostat is satisfied, the amplifier cuts power to the combination gas valves of the Master unit and all Slave units which prevents gas flow to both the main and pilot burners. The firing rate shall be controlled by a
- (opt) duct sensor with remote temperature adjuster.
  - (opt) duct sensor with remote temperature adjuster and room override thermostat.
  - (opt) room thermostat.
- E.10.f. (opt) Electronic Modulation Slave gas controls with an electronic modulating/regulating gas control, combination gas valve, and an ignition control, but does not include a modulating amplifier and does not require a discharge air thermostat. The modulating gas valve receives the modulation percentage from the Master duct furnace. Up to three Slave duct furnaces can be connected to one Master unit.
- E.10.g. (opt) Electronic Modulation - 0-10 Vdc External Input. Allows for control of the duct furnace firing rate by a Building Management System (BMS). Utilizes an electronic modulating/regulating gas control, combination gas valve, an ignition control, modulating signal conditioner, and an inverted 0-10 Vdc input signal provided by a BMS (0 Vdc being high fire and 10 Vdc being low fire). The gas controls can modulate the gas flow between 40% and 100% full fire. When the BMS thermostat (supplied by others) is satisfied, the BMS heat contact (supplied by others) opens to cut power to the combination gas valve which prevents gas flow to both the main and pilot burners.
- E.10.h. (opt) Electronic Modulation - 4-20 mA External Input. Allows for control of the duct furnace firing rate by a Building Management System (BMS). Utilizes an electronic modulating/regulating gas control, combination gas valve, an ignition control, modulating signal conditioner, and an inverted 4-20 mA input signal provided by a BMS (4 mA being high fire and 20 mA being low fire). The gas controls can modulate the gas flow between 40% and 100% full fire. When the BMS thermostat (supplied by others) is satisfied, the BMS heat contact (supplied by others) opens to cut power to the combination gas valve which prevents gas flow to both the main and pilot burners.
- E.11. A 1/8" manifold pressure tap shall be located after all valves to test the manifold pressure directly before the main burner orifices.
- E.12. The unit shall be provided with a single gas control transformer to step down the supply voltage to 24V.
- E.13. Separate line voltage and low voltage terminal strips shall be provided to prevent the unit from being miswired for premium unit and low voltage terminals for standard units.
- E.14. Automatic reset high limit switch.  
(opt) Manual reset high limit switch.
- E.15. Provide the following factory installed options:
- E.15.a (opt) A low gas pressure switch prevents the burner from firing if the inlet gas pressure is below the minimum gas pressure.
- E.15.b. (opt) A high gas pressure switch which prevents the burner from firing if the manifold gas pressure is above the maximum manifold gas pressure.
- E.15.c. (opt) An air flow proving which shall be an adjustable differential pressure switch to insure air flow across the heat exchanger before allowing the gas controls to be energized.
- E.15.d. (opt) A timed freeze protection discharge air thermostat used to prevent building freeze up in the event of a burner failure. The timer shall be adjustable from 1 to 5 minutes.
- E.15.e. (opt) A time delay relay which delays the start of the blower to allow the heat exchanger a warm-up period after a call for heat. The time delay relay shall also continue the blower operation after the thermostat has been satisfied to remove any residual heat on the heat exchanger.
- E.16. The unit shall be orificed for up to 2000' elevation above sea level.  
(opt) The unit shall be orificed for \_\_\_\_\_ elevation above sea level.

**J. Accessory Control Devices**

*The following field installed accessory control devices shall be provided with the unit:*

- J.1. A digital 7-day / 24-hour timer with SPDT switching. The timer shall have 16 programming set points with 7-day power outage carry-over.
- J.2. A push pin style appliance timer with SPST switching with 12 settings per day (2 hour per pin time increments).
- J.3. A mild temperature thermostat used to automatically lock out the gas controls when the outdoor temperature reaches the desired set point.
- J.4. A low profile duct style photoelectronic smoke detector with two DPDT contacts.
- J.4.a. A smoke detector tube extension for duct widths between 1 to 2 feet.
- J.4.b. A smoke detector tube extension for duct widths between 2 to 4 feet.
- J.4.c. A smoke detector tube extension for duct widths between 4 to 8 feet.
- J.5. A 1-5 psi gas pressure regulator to reduce the inlet gas pressure for the operating controls.
- J.6. A clear plastic thermostat guard with two keys for room thermostats.
- J.7. A DPDT summer winter switch for continuous fan in the summer position and intermittent fan and burner in the winter position.

**K. Thermostats**

*The unit shall be provided with the following thermostat*

- K.1. A single stage room thermostat with a 55°-95°F range.
- K.2. A single stage room thermostat with a 45°-75°F range
- K.3. A single stage room thermostat with a 45°-75°F range with sub-base for System auto/off and Fan auto/on control.
- K.4. A 7-day programmable room thermostat with with one heat and one cool stage. The thermostat shall have Fan on/auto and System heat/off/cool/auto switching. Programmable for 2 to 4 events per day with override feature.
- K.5. <blank>
- K.6. A two-stage digital non-programmable room stat with switching and a range of 40-90°F.
- K.7. A 7-day programmable room thermostat with with two heat and two cool stages. The thermostat shall have Fan on/auto and System heat/off/cool/auto switching. Programmable for 2 to 4 events per day with override feature and one auxiliary output terminal for damper control.
- K.8. A factory installed two-stage duct thermostat with a 0°-100°F range and 20 foot capillary.
- K.9. A field installed two-stage duct thermostat with a 0°-100°F range and 20 foot capillary.
- K.10. A factory installed two-stage duct thermostat with a 55°-175°F range and 20 foot capillary.
- K.11. A field installed two-stage duct thermostat with a 55°-175°F range and 20 foot capillary.
- K.12. A two-stage electronic duct thermostat with field installed temperature sensor, temperature selector and one stage adder.
- K.13. A remote set point adjuster for the electronic modulating duct thermostat.
- K.14. A field installed electronic modulating duct thermostat and set point adjuster with a range of 55°-90°F.
- K.15. A room override thermostat with a range of 40°-90°F for use with the electronic modulating duct thermostat.
- K.16. An electronic modulating room thermostat with a 60°-85°F range.

# MODEL NOMENCLATURE



1	2	3	4 5 6	7	8	9	10	11	12	13	14	15
PT	UC	V	MBH	HE	DS	AS	ATR	GT	GV	SS	SV	TR

**1 - Product Type (PT)**

D - Indoor HVAC Unit

**2 - Unit Configuration (UC)**

F - Furnace

**3 - Venting (V)**

G - Gravity

P - Power Vented

**4,5,6 - Furnace Input Rating (MBH)**

75 - 75,000 Btu/Hr Input

100 - 100,000 Btu/Hr Input

125 - 125,000 Btu/Hr Input

150 - 150,000 Btu/Hr Input

175 - 175,000 Btu/Hr Input

200 - 200,000 Btu/Hr Input

225 - 225,000 Btu/Hr Input

250 - 250,000 Btu/Hr Input

300 - 300,000 Btu/Hr Input

350 - 350,000 Btu/Hr Input

400 - 400,000 Btu/Hr Input

**7 - Heat Exchanger/Burner/Drip Pan Material (HE)**

A - Aluminized Steel

S - 409 Stainless Steel Heat Exchanger/Burner

T - 409 Stainless Steel Heat Exchanger/Burner/Drip Pan

**8 - Development Sequence Designation (DS)**

F - Single Stage

M - 2-stage or Modulating

**9 - Access Side (AS)**

R - Right Hand

L - Left hand

**10 - Air Temperature Rise (ATR)**

N - Not Used

**11 - Gas Type (GT)**

N - Natural with ignition controller

P - Propane with ignition controller

**12 - Gas Valve (GV)**

1 - Single Stage

5 - Electronic Modulation Master

2 - Two Stage

6 - Electronic Modulation Slave

3 - Mechanical Modulation 7 - Electronic Modulation 0-10 Vdc External Input

4 - Electronic Modulation 8 - Electronic Modulation 4-20 mA External Input

**13 - Additional Safety Switches (SS)**

4 - No Switches (Standard) 1 - Low Gas Pressure Switch (Premium)

0 - No Switches (Premium) 2 - High Gas Pressure Switch (Premium)

3 - High and Low Gas Pressure Switch (Premium)

**14 - Supply Voltage (SV)**

A - 115/60/1

E - 230/60/3

B - 208/60/1

F - 460/60/3

C - 230/60/1

G - 575/60/3

D - 200-208/60/3

**15 - Transformer (TR)**

1 - 40 VA

4 - 250 VA

2 - 75 VA

0 - None

## INDOOR AIR SOLUTIONS

The Modine brand has been the industry standard since Arthur B. Modine invented and patented the first lightweight, suspended hydronic unit heater in 1923.

No other manufacturer can provide the combined application flexibility, technical expertise and fast delivery found at Modine.

Consult your local Modine distributor for help in solving your indoor air problems.

Products from Modine are designed to provide indoor air-comfort solutions for commercial, institutional and industrial applications. Whatever your heating, ventilating and cooling requirements, Modine has the product to satisfy your needs, including:

- Gas-fired unit heaters
- Gas-fired duct furnaces
- Gas-fired high-intensity infrared heaters
- Gas-fired low-intensity infrared heaters
- Steam/hot water unit heaters
- Steam/hot water cabinet unit heaters
- Steam/hot water commercial fin tube radiation
- Oil-fired unit heaters
- Electric unit heaters
- Indoor gravity and power vented single and multiple duct furnace make-up air units
- Indoor separated combustion single and multiple duct furnace make-up air units
- Outdoor single and multiple duct furnace make-up air units
- Direct-fired make-up air units

With burner capacities up to 7,862,000 Btu/hr and air-handling capacities as high as 60,000 CFM, Modine products are compatible with every fuel type, including:

- **Natural or Propane Gas** • **Steam/Hot Water** • **Oil** • **Electric**

Specific catalogs and computer-generated heat-loss calculations are available for each product. Catalogs 75-136 and 75-137 provide details on all Modine HVAC equipment.

Distributed By:



**Commercial Products Group**  
**Modine Manufacturing Company**

1500 DeKoven Avenue  
Racine, Wisconsin 53403-2552

Phone: 1.800.828.4328 (HEAT)

Fax: 1.800.204.6011

[www.modine.com](http://www.modine.com)

© Modine Manufacturing Company 2008  
12/08 - Litho in USA