

GATE VALVES

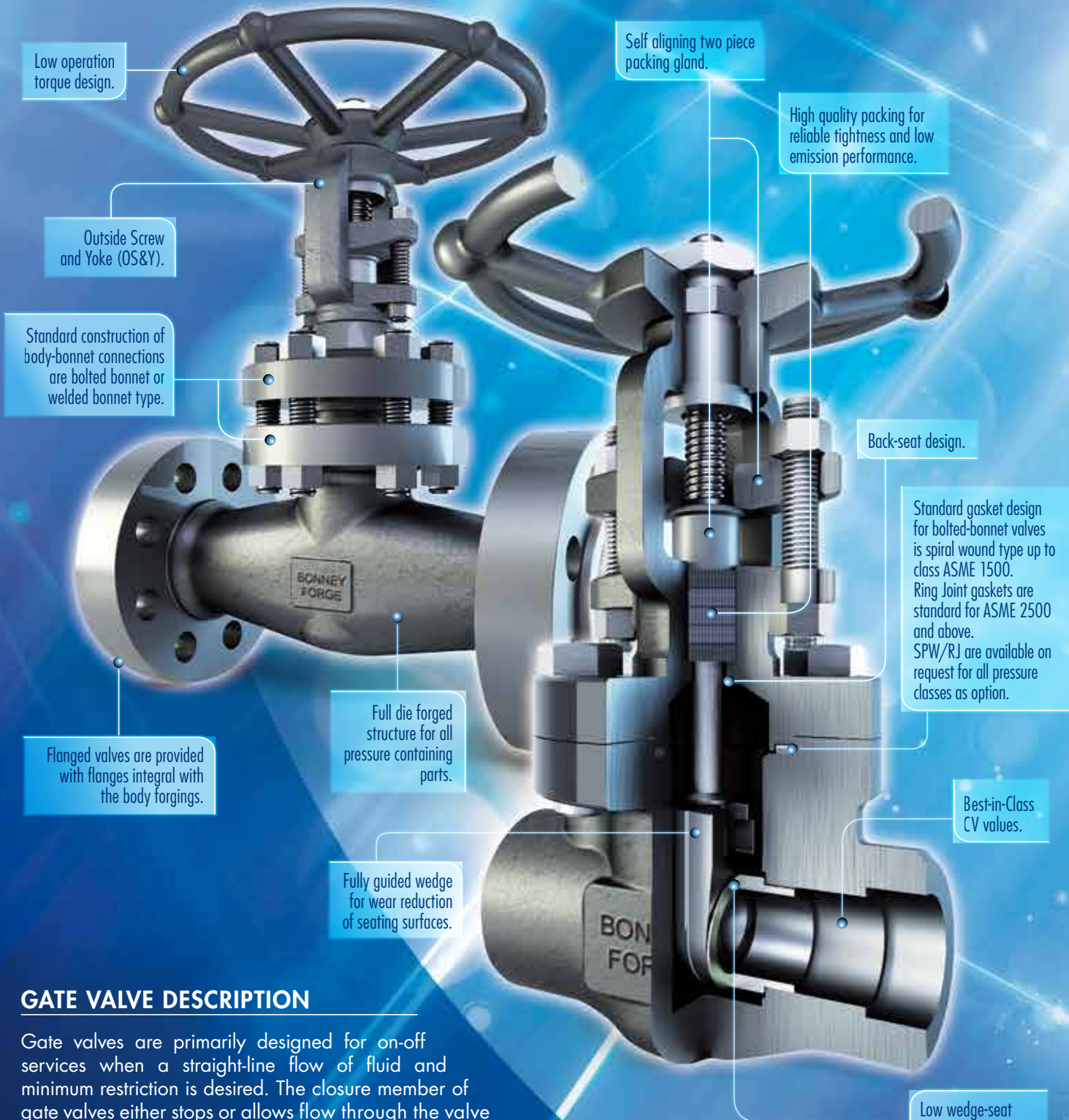

Low operation torque design.

Outside Screw and Yoke (OS&Y).

Standard construction of body-bonnet connections are bolted bonnet or welded bonnet type.

Flanged valves are provided with flanges integral with the body forgings.

Full die forged structure for all pressure containing parts.

Fully guided wedge for wear reduction of seating surfaces.

Self aligning two piece packing gland.

High quality packing for reliable tightness and low emission performance.

Back-seat design.

Standard gasket design for bolted-bonnet valves is spiral wound type up to class ASME 1500. Ring Joint gaskets are standard for ASME 2500 and above. SPW/RJ are available on request for all pressure classes as option.

Best-in-Class CV values.

Low wedge-seat friction coefficient for reliable sealing & long service life.

GATE VALVE DESCRIPTION

Gate valves are primarily designed for on-off services when a straight-line flow of fluid and minimum restriction is desired. The closure member of gate valves either stops or allows flow through the valve and acts somewhat like the opening or closing of a gate and is called, appropriately, the gate valve.

The gate is also shown as a wedge, due to the shape it resembles. When the valve is open, the closure member is fully drawn up into the valve, leaving a complete opening for the flow stream. Therefore, there is little pressure drop or flow restriction through the valve. Gate valves are used in many industrial applications including the oil and gas industry, pharmaceuticals, manufacturing, automotive, and marine. Gate valves are not suitable for throttling purposes.



















P&ID SYMBOL

















STANDARD CONFIGURATIONS



SECTION INDEX OF GATE VALVES

PAGE	DESCRIPTION	SYM
B-3	BOLTED BONNET GATE VALVES BASIC CONFIGURATION	
	THREADED AND SOCKET WELD ENDS	
B-4	BOLTED BONNET GATE VALVES BASIC CONFIGURATION	
	ASME INTEGRAL FLANGED ENDS	
B-5	BOLTED BONNET GATE VALVES CRYOGENIC CONFIGURATION	
	THREADED AND SOCKET WELD ENDS	
B-6	BOLTED BONNET GATE VALVES CRYOGENIC CONFIGURATION	
	ASME INTEGRAL FLANGED ENDS	
B-7	BOLTED BONNET GATE VALVES BELLOW SEAL CONFIGURATION	
	THREADED AND SOCKET WELD ENDS	
B-8	BOLTED BONNET GATE VALVES BELLOW SEAL CONFIGURATION	
	ASME INTEGRAL FLANGED ENDS	
B-9	WELDED BONNET GATE VALVES BASIC CONFIGURATION	
	THREADED AND SOCKET WELD ENDS	
B-10	WELDED BONNET GATE VALVES BASIC CONFIGURATION	
	ASME INTEGRAL FLANGED ENDS	
B-11	WELDED BONNET GATE VALVES CRYOGENIC CONFIGURATION	
	THREADED AND SOCKET WELD ENDS	

PAGE	DESCRIPTION	SYM
B-12	WELDED BONNET GATE VALVES CRYOGENIC CONFIGURATION	
	ASME INTEGRAL FLANGED ENDS	
B-13	WELDED BONNET GATE VALVES BELLOW SEAL CONFIGURATION	
	THREADED AND SOCKET WELD ENDS	
B-14	WELDED BONNET GATE VALVES BELLOW SEAL CONFIGURATION	
	ASME INTEGRAL FLANGED ENDS	
B-15	BOLTED BONNET GATE VALVES INTEGRAL REINFORCED EXTENDED BODY CONFIGURATION	
	VALVOLET AND LIP ENDS VALVES	
B-15	BOLTED BONNET GATE VALVES EXTENDED BODY CONFIGURATION	
	THREADED AND WELDING ENDS VALVES	
B-16	WELDED BONNET GATE VALVES INTEGRAL REINFORCED EXTENDED BODY CONFIGURATION	
	VALVOLET AND LIP ENDS VALVES	
B-16	WELDED BONNET GATE VALVES EXTENDED BODY CONFIGURATION	
	THREADED AND WELDING ENDS VALVES	
B-17	AVAILABLE OPTIONS FOR GATE VALVES	

APPLICABLE STANDARDS	
DESIGN	API 602 - ISO 15761 - ASME B16.34
INSPECTION & TESTING	API 598
MARKING	MSS SP-25
RATING	ASME B16.34
FUGITIVE EMISSION	API 624 - ISO 15848

GATE VALVES

BOLTED BONNET GATE VALVES BASIC CONFIGURATION THREADED AND SOCKET WELD ENDS



WORKING PRESSURE RATING	SIZE		STANDARD DESIGN TYPE	A		B		C		H		WEIGHT		FIGURE
	NPS	DN		mm	in	mm	in	mm	in	mm	in	kg	lb	
ASME 800	1/2"	15	S1	80	3.15	9.6	0.38	88	3.5	152	6.0	1.9	4.2	HL 103
	3/4"	20	S1	90	3.54	14	0.55	88	3.5	158	6.2	2.3	5.1	HL 104
	1"	25	S1	110	4.33	18	0.71	97	3.8	196	7.7	3.6	7.9	HL 105
	1-1/2"	40	S1	127	5.00	30	1.18	138	5.4	255	10.0	7.3	16.1	HL 107
	2"	50	S1	134	5.28	37.5	1.47	138	5.4	290	11.4	7.6	16.8	HL 108
ASME 1500	1/2"	15	S1	90	3.54	9.6	0.38	88	3.5	152	6.0	2.4	5.3	9HL 103
	3/4"	20	S1	110	4.33	14	0.55	97	3.8	190	7.5	3.9	8.6	9HL 104
	1"	25	S1	127	5.00	18	0.71	138	5.4	220	8.7	6.1	13.4	9HL 105
	1-1/2"	40	S1	127	5.00	30	1.18	138	5.4	282	11.1	10.8	23.8	9HL 107
	2"	50	S1	210	8.27	37.5	1.47	138	5.4	345	13.6	20.5	45.2	9HL 108
ASME 800	1/4"	6	S1	80	3.15	8	0.31	88	3.5	152	6.0	2.1	4.6	H 101
	3/8"	10	S1	80	3.15	9.6	0.38	88	3.5	152	6.0	2.1	4.6	H 102
	1/2"	15	S1	90	3.54	14	0.55	88	3.5	158	6.2	2.3	5.1	H 103
	3/4"	20	S1	110	4.33	18	0.71	97	3.8	196	7.7	3.7	8.2	H 104
	1"	25	S1	127	5.00	24	0.94	138	5.4	225	8.9	5.9	13.0	H 105
	1-1/4"	32	S1	127	5.00	30	1.18	138	5.4	255	10.0	7.4	16.3	H 106
	1-1/2"	40	S1	134	5.28	37.5	1.47	138	5.4	290	11.4	8.3	18.3	H 107
	2"	50	S1	152	5.98	48	1.89	172	6.8	358	14.1	12.5	27.6	H 108
	3"	80	S1	203	7.99	70	2.76	234	9.2	460	18.1	37	81.6	H 1010
ASME 1500	1/4"	6	S1	90	3.54	8	0.31	88	3.5	153	6.0	2.4	5.3	9H 101
	3/8"	10	S1	90	3.54	9.6	0.38	88	3.5	153	6.0	2.4	5.3	9H 102
	1/2"	15	S1	110	4.33	14	0.55	97	3.8	190	7.5	4.1	9.0	9H 103
	3/4"	20	S1	127	5.00	18	0.71	138	5.4	220	8.7	6.2	13.7	9H 104
	1"	25	S1	127	5.00	24	0.94	138	5.4	250	9.8	8	17.6	9H 105
	1-1/4"	32	S1	127	5.00	30	1.18	138	5.4	282	11.1	10.5	23.1	9H 106
	1-1/2"	40	S1	127	5.00	37.5	1.47	138	5.4	290	11.4	11	24.3	9H 107
ASME 2500	1/2"	15	S2	150	5.91	11.5	0.45	138	5.4	282	11.1	10	22.0	25HR 103
	3/4"	20	S2	150	5.91	15	0.59	138	5.4	287	11.3	10	22.0	25HR 104
	1"	25	S2	210	8.27	19.5	0.77	172	6.8	348	13.7	22	48.5	25HR 105
	1-1/2"	40	S2	230	9.06	28	1.10	234	9.2	406	16.0	37	81.6	25HR 107
	2"	50	S2	230	9.06	35	1.38	234	9.2	437	17.2	36	86	25HR 108

STANDARD BORE

FULL BORE

BFE reserves the right to change designs, dimensions or specifications without notice.

PRODUCT FEATURES:

- Socket Weld acc.to ASME B16.11. • Screwed ends (NPT) acc.to ASME B1.20.1. • Butt welding ends acc.to ASME B16.25. • End to End acc.to manufacturer standard.

DESIGN TYPE S1 SPIRAL WOUND GASKET BODY-BONNET CONNECTION

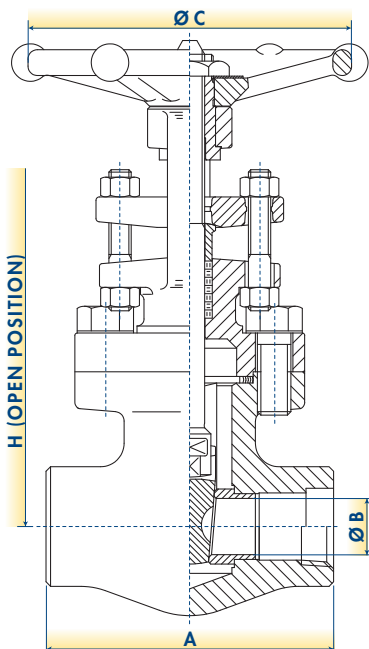

DESIGN TYPE S2 RING JOINT GASKET BODY-BONNET CONNECTION

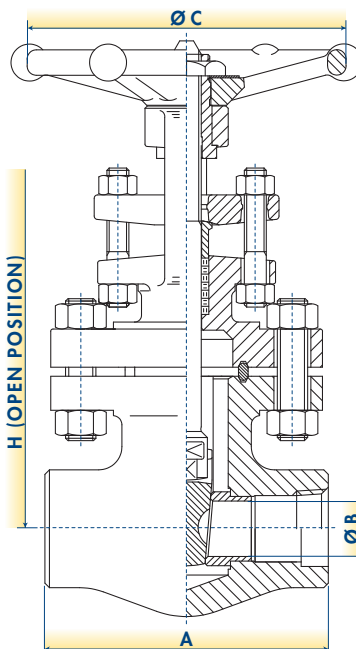

OTHER END CONNECTION TYPES AVAILABLE

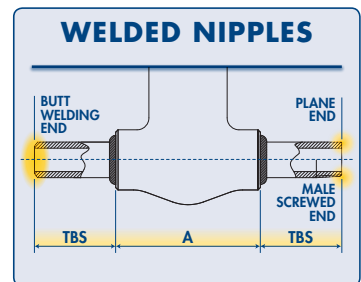
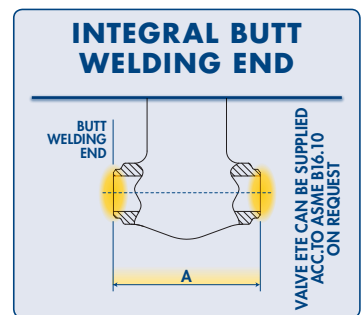

BOLTED BONNET GATE VALVES BASIC CONFIGURATION ASME INTEGRAL FLANGED ENDS



WORKING PRESSURE RATING	SIZE		STANDARD DESIGN TYPE	A-RF		A-RJ		B		C		H		WEIGHT		FIGURE	
	NPS	DN		mm	in	mm	in	mm	in	mm	in	mm	in	kg	lb		
ASME 150	1/2"	15	S1	108	4.25	N.A.	N.A.	9.6	0.38	88	3.5	175	6.9	2.9	6.3	L1-103	STANDARD BORE
	3/4"	20	S1	117	4.62	N.A.	N.A.	14	0.55	88	3.5	182	7.2	3.7	8.2	L1-104	
	1"	25	S1	127	5.00	140	5.50	18	0.71	97	3.8	212	8.3	5.2	11.5	L1-105	
	1-1/2"	40	S1	165	6.50	178	7.00	30	1.18	138	5.4	255	10.0	9.6	21.2	L1-107	
	2"	50	S1	178	7.00	191	7.50	37.5	1.47	138	5.4	290	11.4	13.2	29.1	L1-108	
ASME 300	1/2"	15	S1	140	5.50	151	5.94	9.6	0.38	88	3.5	175	6.9	3.6	7.9	L3-103	
	3/4"	20	S1	152	6.00	165	6.50	14	0.55	88	3.5	182	7.2	5.2	11.5	L3-104	
	1"	25	S1	165	6.50	178	7.00	18	0.71	97	3.8	212	8.3	6.7	14.8	L3-105	
	1-1/2"	40	S1	190	7.50	203	8.00	30	1.18	138	5.4	240	9.4	13	28.7	L3-107	
	2"	50	S1	216	8.50	232	9.12	37.5	1.47	138	5.4	290	11.4	15.3	33.7	L3-108	
ASME 600	1/2"	15	S1	165	6.50	163	6.44	9.6	0.38	88	3.5	159	6.3	4.3	9.5	L6-103	
	3/4"	20	S1	190	7.50	190	7.50	14	0.55	88	3.5	185	7.3	7	15.4	L6-104	
	1"	25	S1	216	8.50	216	8.50	18	0.71	97	3.8	215	8.5	10	22.0	L6-105	
	1-1/2"	40	S1	241	9.50	241	9.50	30	1.18	138	5.4	255	10.0	18	39.7	L6-107	
	2"	50	S1	292	11.50	295	11.62	37.5	1.47	138	5.4	305	12.0	28	61.7	L6-108	
ASME 1500	1/2"	15	S1	216	8.50	216	8.50	9.5	0.37	88	3.5	185	7.3	7.5	16.5	15FL 103	
	3/4"	20	S1	229	9.00	229	9.00	14	0.55	97	3.8	215	8.5	12	26.5	15FL 104	
	1"	25	S1	254	10.00	254	10.00	18	0.71	138	5.4	245	9.6	15	33.0	15FL 105	
	1-1/2"	40	S1	305	12.00	305	12.00	30	1.18	172	6.8	295	11.6	28.2	62.2	15FL 107	
	2"	50	S1	368	14.50	371.5	14.62	37.5	1.47	172	6.8	330	13.0	53	116.8	15FL 108	
ASME 150	1/2"	15	S1	108	4.25	N.A.	N.A.	14	0.55	88	3.5	175	6.9	3.2	7.0	1-103	FULL BORE
	3/4"	20	S1	117	4.62	N.A.	N.A.	18	0.71	97	3.8	210	8.3	4.7	10.4	1-104	
	1"	25	S1	127	5.00	140	5.50	24	0.94	138	5.4	230	9.1	6.1	13.4	1-105	
	1-1/2"	40	S1	165	6.50	178	7.00	37.5	1.47	138	5.4	290	11.4	11.4	25.1	1-107	
	2"	50	S1	178	7.00	191	7.50	48	1.89	172	6.8	340	13.4	18	39.7	1-108	
ASME 300	1/2"	15	S1	140	5.50	151	5.94	14	0.55	88	3.5	175	6.9	3.8	8.4	3-103	
	3/4"	20	S1	152	6.00	165	6.50	18	0.71	97	3.8	210	8.3	5.6	12.3	3-104	
	1"	25	S1	165	6.50	178	7.00	24	0.94	138	5.4	230	9.1	7.1	15.7	3-105	
	1-1/2"	40	S1	190	7.50	203	8.00	37.5	1.47	138	5.4	290	11.4	13.5	29.8	3-107	
	2"	50	S1	216	8.50	232	9.12	48	1.89	172	6.8	340	13.4	19	41.9	3-108	
ASME 600	1/2"	15	S1	165	6.50	163	6.44	14	0.55	88	3.5	175	6.9	4.3	9.5	6-103	
	3/4"	20	S1	190	7.50	190	7.50	18	0.71	97	3.8	215	8.5	7	15.4	6-104	
	1"	25	S1	216	8.50	216	8.50	24	0.94	138	5.4	240	9.4	10	22.0	6-105	
	1-1/2"	40	S1	241	9.50	241	9.50	37.5	1.47	138	5.4	295	11.6	18	39.7	6-107	
	2"	50	S1	292	11.50	295	11.62	48	1.89	172	6.8	360	14.2	28	61.7	6-108	
ASME 1500	1/2"	15	S1	216	8.50	216	8.50	14	0.55	97	3.8	215	8.5	8.2	18.0	15F 103	
	3/4"	20	S1	229	9.00	229	9.00	18	0.71	138	5.4	250	9.8	13	28.7	15F 104	
	1"	25	S1	254	10.00	254	10.00	24	0.94	138	5.4	270	10.6	16.2	35.7	15F 105	
	1-1/2"	40	S1	305	12.00	305	12.00	37.5	1.47	172	6.8	350	13.8	29	64.0	15F 107	
	2"	50	S1	368	14.50	371.5	14.62	48	1.89	234	9.2	445	17.5	55	121.3	15F 108	
ASME 2500	1/2"	15	S2	264	10.38	264	10.38	11.5	0.45	138	5.4	282	11.1	16.2	35.7	25RF 103	
	3/4"	20	S2	273	10.75	273	10.75	15	0.59	138	5.4	290	11.4	17.6	38.8	25RF 104	
	1"	25	S2	308	12.12	308	12.12	19.5	0.77	172	6.8	335	13.2	29	63.9	25RF 105	
	1-1/2"	40	S2	384	15.12	387	15.24	28	1.10	234	9.2	406	16.0	60	132.3	25RF 107	
	2"	50	S2	451	17.75	454	17.87	38	1.50	320	12.6	415	16.3	65	143.3	25RF 108	

BFE reserves the right to change designs, dimensions or specifications without notice.

PRODUCT FEATURES:

- Flanged ends acc. to ASME B16.5.
- Face to Face acc. to ASME B16.10.

DESIGN TYPE S1

SPIRAL WOUND GASKET BODY-BONNET CONNECTION

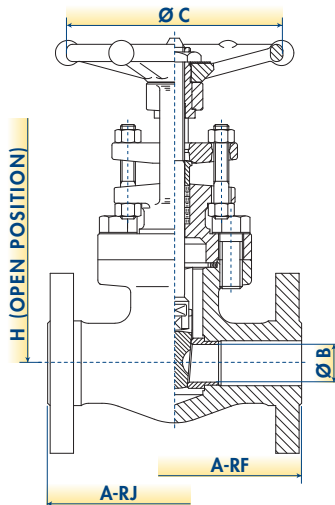

DESIGN TYPE S2

RING JOINT GASKET BODY-BONNET CONNECTION

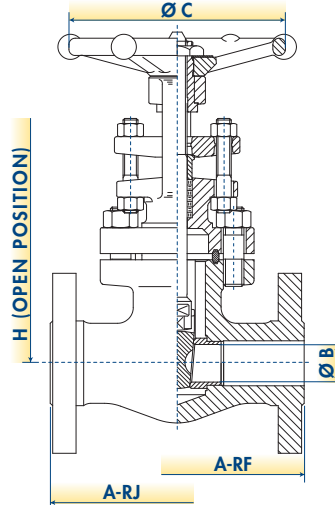

GATE VALVES

BOLTED BONNET GATE VALVES CRYOGENIC CONFIGURATION THREADED AND SOCKET WELD ENDS



WORKING PRESSURE RATING	SIZE		STANDARD DESIGN TYPE	A		B		C		H		WEIGHT		FIGURE
	NPS	DN		mm	in	mm	in	mm	in	mm	in	kg	lb	
ASME 800	1/2"	15	S1	80	3.15	9.6	0.38	88	3.5	406	16.0	3.4	7.5	CL 103
	3/4"	20	S1	90	3.54	14	0.55	88	3.5	412	16.2	3.5	7.7	CL 104
	1"	25	S1	110	4.33	18	0.71	97	3.8	450	17.7	5	11.0	CL 105
	1-1/2"	40	S1	127	5.00	30	1.18	138	5.4	509	20.0	9.6	21.2	CL 107
	2"	50	S1	134	5.28	37.5	1.47	138	5.4	544	21.4	12.5	27.6	CL 108
ASME 1500	1/2"	15	S1	90	3.54	9.6	0.38	88	3.5	406	16.0	3.7	8.2	9CL 103
	3/4"	20	S1	110	4.33	14	0.55	97	3.8	444	17.5	5.3	11.7	9CL 104
	1"	25	S1	127	5.00	18	0.71	138	5.4	474	18.7	8.5	18.7	9CL 105
	1-1/2"	40	S1	127	5.00	30	1.18	138	5.4	536	21.1	13.6	30.0	9CL 107
	2"	50	S1	210	8.27	37.5	1.47	138	5.4	599	23.6	26	57.3	9CL 108
ASME 800	1/4"	6	S1	80	3.15	8	0.31	88	3.5	406	16.0	3.4	7.5	C 101
	3/8"	10	S1	80	3.15	9.6	0.38	88	3.5	406	16.0	3.4	7.5	C 102
	1/2"	15	S1	90	3.54	14	0.55	88	3.5	412	16.2	3.5	7.7	C 103
	3/4"	20	S1	110	4.33	18	0.71	97	3.8	450	17.7	5.1	11.2	C 104
	1"	25	S1	127	5.00	24	0.94	138	5.4	479	18.9	8.2	18.1	C 105
	1-1/4"	32	S1	127	5.00	30	1.18	138	5.4	509	20.0	12	26.5	C 106
	1-1/2"	40	S1	134	5.28	37.5	1.47	138	5.4	544	21.4	16	35.3	C 107
	2"	50	S1	152	5.98	48	1.89	172	6.8	612	24.1	23	50.7	C 108
	3"	80	S1	203	7.99	70	2.76	234	9.2	714	28.1	43	94.8	C 1010
ASME 1500	1/4"	6	S1	90	3.54	8	0.31	88	3.5	407	16.0	3.5	7.7	9C 101
	3/8"	10	S1	90	3.54	9.6	0.38	88	3.5	407	16.0	3.5	7.7	9C 102
	1/2"	15	S1	110	4.33	14	0.55	97	3.8	444	17.5	5.5	12.1	9C 103
	3/4"	20	S1	127	5.00	18	0.71	138	5.4	474	18.7	7.8	17.2	9C 104
	1"	25	S1	127	5.00	24	0.94	138	5.4	504	19.8	11	24.3	9C 105
	1-1/4"	32	S1	127	5.00	30	1.18	138	5.4	536	21.1	14.5	32.0	9C 106
	1-1/2"	40	S1	127	5.00	37.5	1.47	138	5.4	544	21.4	25.6	56.4	9C 107
ASME 2500	1/2"	15	S2	150	5.91	11.5	0.45	138	5.4	536	21.1	13	28.7	25CHR 103
	3/4"	20	S2	150	5.91	15	0.59	138	5.4	541	21.3	13	28.7	25CHR 104
	1"	25	S2	210	8.27	19.5	0.77	172	6.8	602	23.7	26	57.3	25CHR 105
	1-1/2"	40	S2	230	9.06	28	1.10	234	9.2	660	26.0	42	92.6	25CHR 107
	2"	50	S2	230	9.06	35	1.38	234	9.2	691	27.2	43	94.8	25CHR 108

STANDARD BORE

FULL BORE

BFE reserves the right to change designs, dimensions or specifications without notice.

PRODUCT FEATURES:

- Socket Weld acc.to ASME B16.11. • Screwed ends (NPT) acc.to ASME B1.20.1. • Butt welding ends acc.to ASME B16.25. • End to End acc.to manufacturer standard. • Cryogenic design acc.to BS 6364. • Body Cavity Vent Hole.

DESIGN TYPE S1 SPIRAL WOUND GASKET BODY-BONNET CONNECTION

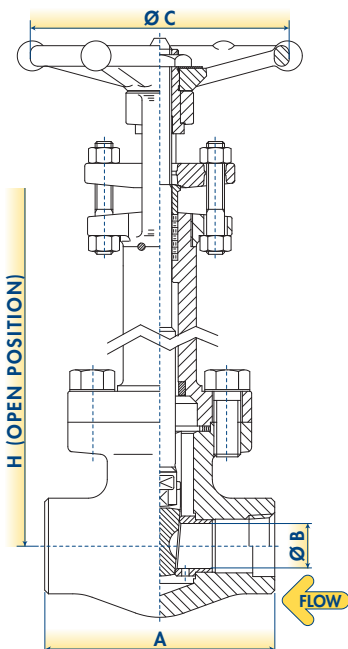

DESIGN TYPE S2 RING JOINT GASKET BODY-BONNET CONNECTION

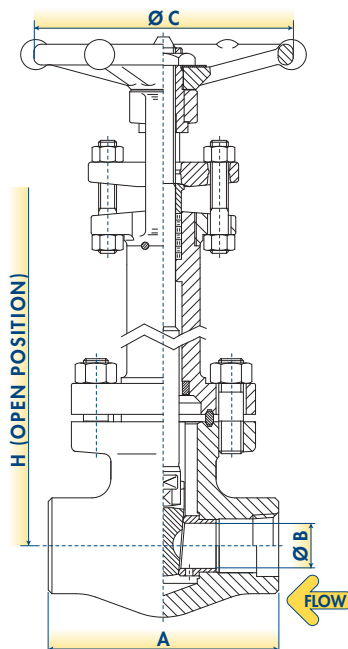

OTHER END CONNECTION TYPES AVAILABLE

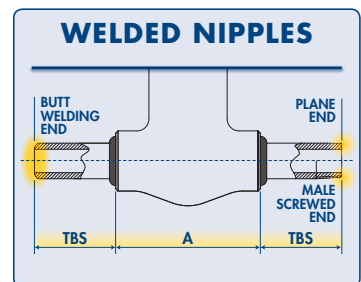
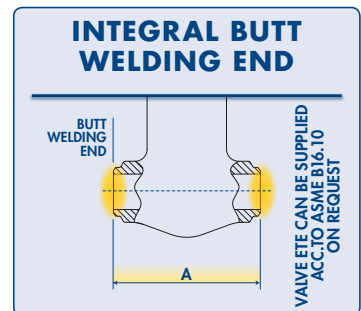

BOLTED BONNET GATE VALVES CRYOGENIC CONFIGURATION ASME INTEGRAL FLANGED ENDS



WORKING PRESSURE RATING	SIZE		STANDARD DESIGN TYPE	A-RF		A-RJ		B		C		H		WEIGHT		FIGURE
	NPS	DN		mm	in	mm	in	mm	in	mm	in	mm	in	kg	lb	
ASME 150	1/2"	15	S1	108	4.25	N.A.	N.A.	9.6	0.38	88	3.5	429	16.9	4.3	9.5	1CL 103
	3/4"	20	S1	117	4.62	N.A.	N.A.	14	0.55	88	3.5	436	17.2	5.1	11.2	1CL 104
	1"	25	S1	127	5.00	140	5.50	18	0.71	97	3.8	466	18.3	6.4	14.1	1CL 105
	1-1/2"	40	S1	165	6.50	178	7.00	30	1.18	138	5.4	509	20.0	12.4	27.3	1CL 107
	2"	50	S1	178	7.00	191	7.50	37.5	1.47	138	5.4	544	21.4	16	35.3	1CL 108
ASME 300	1/2"	15	S1	140	5.50	151	5.94	9.6	0.38	88	3.5	429	16.9	5.1	11.2	3CL 103
	3/4"	20	S1	152	6.00	165	6.50	14	0.55	88	3.5	436	17.2	6.1	14.3	3CL 104
	1"	25	S1	165	6.50	178	7.00	18	0.71	97	3.8	466	18.3	7.8	17.2	3CL 105
	1-1/2"	40	S1	190	7.50	203	8.00	30	1.18	138	5.4	494	19.4	15	33.1	3CL 107
	2"	50	S1	216	8.50	232	9.12	37.5	1.47	138	5.4	544	21.4	19	41.9	3CL 108
ASME 600	1/2"	15	S1	165	6.50	163	6.44	9.6	0.38	88	3.5	413	16.3	5.3	11.7	6CL 103
	3/4"	20	S1	190	7.50	190	7.50	14	0.55	88	3.5	439	17.3	7.4	16.3	6CL 104
	1"	25	S1	216	8.50	216	8.50	18	0.71	97	3.8	469	18.5	13	28.7	6CL 105
	1-1/2"	40	S1	241	9.50	241	9.50	30	1.18	138	5.4	509	20.0	21	46.3	6CL 107
	2"	50	S1	292	11.50	295	11.62	37.5	1.47	138	5.4	559	22.0	32	70.5	6CL 108
ASME 1500	1/2"	15	S1	216	8.50	216	8.50	9.5	0.37	88	3.5	439	17.3	10.2	22.5	15CF 103
	3/4"	20	S1	229	9.00	229	9.00	14	0.55	97	3.8	469	18.5	14	30.9	15CF 104
	1"	25	S1	254	10.00	254	10.00	18	0.71	138	5.4	499	19.6	17.5	38.6	15CF 105
	1-1/2"	40	S1	305	12.00	305	12.00	30	1.18	172	6.8	549	21.6	31	68.3	15CF 107
	2"	50	S1	368	14.50	371.5	14.62	37.5	1.47	172	6.8	584	23.0	59	130.1	15CF 208
ASME 150	1/2"	15	S1	108	4.25	N.A.	N.A.	14	0.55	88	3.5	429	16.9	4.8	10.6	1C 103
	3/4"	20	S1	117	4.62	N.A.	N.A.	18	0.71	97	3.8	464	18.3	5.9	13.0	1C 104
	1"	25	S1	127	5.00	140	5.50	24	0.94	138	5.4	484	19.1	8.7	19.2	1C 105
	1-1/2"	40	S1	165	6.50	178	7.00	37.5	1.47	138	5.4	544	21.4	14.7	32.4	1C 107
	2"	50	S1	178	7.00	191	7.50	48	1.89	172	6.8	594	23.4	19	41.9	1C 108
ASME 300	1/2"	15	S1	140	5.50	151	5.94	14	0.55	88	3.5	429	16.9	5.1	11.2	3C 103
	3/4"	20	S1	152	6.00	165	6.50	18	0.71	97	3.8	464	18.3	7.2	15.9	3C 104
	1"	25	S1	165	6.50	178	7.00	24	0.94	138	5.4	484	19.1	9.9	21.8	3C 105
	1-1/2"	40	S1	190	7.50	203	8.00	37.5	1.47	138	5.4	544	21.4	16	35.3	3C 107
	2"	50	S1	216	8.50	232	9.12	48	1.89	172	6.8	594	23.4	22	48.5	3C 108
ASME 600	1/2"	15	S1	165	6.50	163	6.44	14	0.55	88	3.5	429	16.9	6.2	13.7	6C 103
	3/4"	20	S1	190	7.50	190	7.50	18	0.71	97	3.8	469	18.5	8.4	18.5	6C 104
	1"	25	S1	216	8.50	216	8.50	24	0.94	138	5.4	494	19.4	15	33.1	6C 105
	1-1/2"	40	S1	241	9.50	241	9.50	37.5	1.47	138	5.4	549	21.6	23	50.7	6C 107
	2"	50	S1	292	11.50	295	11.62	48	1.89	172	6.8	614	24.2	34	75.0	6C 108
ASME 1500	1/2"	15	S1	216	8.50	216	8.50	14	0.55	97	3.8	469	18.5	10.2	22.5	15CF 103
	3/4"	20	S1	229	9.00	229	9.00	18	0.71	138	5.4	504	19.8	14	30.9	15CF 104
	1"	25	S1	254	10.00	254	10.00	24	0.94	138	5.4	524	20.6	17.5	38.6	15CF 105
	1-1/2"	40	S1	305	12.00	305	12.00	37.5	1.47	172	6.8	604	23.8	31	68.3	15CF 107
	2"	50	S1	368	14.50	371.5	14.62	48	1.89	234	9.2	699	27.5	59	130.1	15CF 108
ASME 2500	1/2"	15	S2	264	10.38	264	10.38	11.5	0.45	138	5.4	536	21.1	20	44.1	25CRF 103
	3/4"	20	S2	273	10.75	273	10.75	15	0.59	138	5.4	544	21.4	22	48.5	25CRF 104
	1"	25	S2	308	12.12	308	12.12	19.5	0.77	172	6.8	589	23.2	32	70.5	25CRF 105
	1-1/2"	40	S2	384	15.12	387	15.24	28	1.10	234	9.2	660	26.0	65	143.3	25CRF 107
	2"	50	S2	451	17.75	454	17.87	38	1.50	320	12.6	669	26.3	70	154.3	25CRF 108

STANDARD BORE

FULL BORE

BFC reserves the right to change designs, dimensions or specifications without notice.

PRODUCT FEATURES:

- Flanged ends acc. to ASME B16.5. • Face to Face acc. to ASME B16.10. • Cryogenic design acc. to BS 6364. • Body Cavity Vent Hole.

DESIGN TYPE S1

SPIRAL WOUND GASKET BODY-BONNET CONNECTION

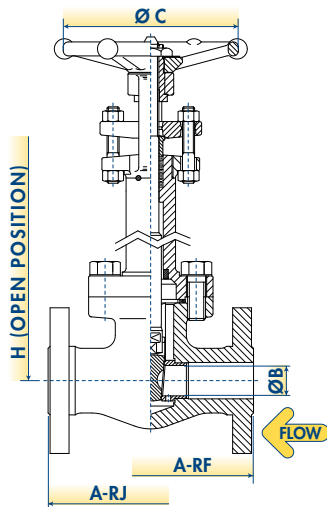

DESIGN TYPE S2

RING JOINT GASKET BODY-BONNET CONNECTION

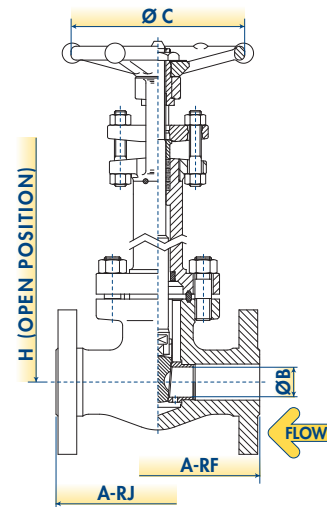

GATE VALVES

BOLTED BONNET GATE VALVES BELLOW SEAL CONFIGURATION THREADED AND SOCKET WELD ENDS



WORKING PRESSURE RATING	SIZE		STANDARD DESIGN TYPE	A		B		C		H		WEIGHT		FIGURE
	NPS	DN		mm	in	mm	in	mm	in	mm	in	kg	lb	
ASME 800	1/2"	15	P4	80	3.15	9.6	0.38	88	3.5	230	9.1	2.7	6.0	SL 103
	3/4"	20	P4	90	3.54	14	0.55	88	3.5	234	9.2	3	6.6	SL 104
	1"	25	P4	110	4.33	18	0.71	97	3.8	285	11.2	4.4	9.7	SL 105
	1-1/2"	40	P4	127	5.00	30	1.18	138	5.4	370	14.6	9.4	20.7	SL 107
	2"	50	P4	134	5.27	37.5	1.47	138	5.4	435	17.1	12.3	27.1	SL 108
ASME 1500	1/2"	15	P4	90	3.54	9.6	0.38	138	5.4	238	9.4	3	6.6	9SL 103
	3/4"	20	P4	110	4.33	14	0.55	138	5.4	293	11.5	5	11.0	9SL 104
	1"	25	P4	127	5.00	18	0.71	138	5.4	343	13.5	7	15.4	9SL 105
	1-1/2"	40	P4	127	5.00	30	1.18	234	9.2	450	17.7	10	22.0	9SL 107
	2"	50	P4	210	8.27	37.5	1.47	234	9.2	588	23.1	24	52.9	9SL 108
ASME 800	1/4"	6	P4	80	3.15	8	0.31	88	3.5	230	9.1	2.7	6.0	S 101
	3/8"	10	P4	80	3.15	9.6	0.38	88	3.5	230	9.1	2.7	6.0	S 102
	1/2"	15	P4	90	3.54	14	0.55	88	3.5	234	9.2	2.9	6.4	S 103
	3/4"	20	P4	110	4.33	18	0.71	97	3.8	285	11.2	4.6	10.1	S 104
	1"	25	P4	127	5.00	24	0.94	138	5.4	325	12.8	7.2	15.9	S 105
	1-1/4"	32	P4	127	5.00	30	1.18	138	5.4	370	14.6	10	22.0	S 106
	1-1/2"	40	P4	134	5.27	37.5	1.47	138	5.4	435	17.1	12.8	28.2	S 107
	2"	50	P4	152	6.00	48	1.89	172	6.8	530	20.9	22	48.5	S 108
ASME 1500	1/2"	15	P4	110	4.33	14	0.55	138	5.4	293	11.5	5	11.0	9S 103
	3/4"	20	P4	127	5.00	18	0.71	138	5.4	343	13.5	7	15.4	9S 104
	1"	25	P4	127	5.00	24	0.94	172	6.8	388	15.3	9.5	20.9	9S 105
	1-1/2"	40	P4	210	8.27	37.5	1.47	234	9.2	588	23.1	23.5	51.8	9S 107
	2"	50	P4	210	8.27	48	1.89	320	12.6	590	23.2	40	88.2	9S 108
ASME 2500	1/2"	15	P5	150	5.90	11.5	0.45	172	6.8	430	16.9	7	15.4	25SHR 103
	3/4"	20	P5	150	5.90	15	0.59	172	6.8	450	17.7	7	15.4	25SHR 104
	1"	25	P5	210	8.27	19.5	0.77	234	9.2	510	20.1	17	37.5	25SHR 105
	1-1/2"	40	P5	210	8.27	28	1.10	234	9.2	630	24.8	31	68.3	25SHR 107
	2"	50	P6	230	9.06	35	1.38	300	11.8	880	34.6	47	103.6	25SHR 108

STANDARD BORE

FULL BORE

BFE reserves the right to change designs, dimensions or specifications without notice.

PRODUCT FEATURES:

- Socket Weld acc. to ASME B16.11. • Screwed ends (NPT) acc. to ASME B1.20.1. • Butt welding ends acc. to ASME B16.25. • End to End acc. to manufacturer standard. • Zero emission. • Hydroformed Bellows
- Extension-Bonnet weld acc. to ASME IX. • Grease nipple for yoke sleeve. • Emergency stuffing box as back sealing.

DESIGN TYPE P4 HANDWHEEL OPERATED & SPIRAL WOUND GASKET BODY-BONNET CONNECTION



DESIGN TYPE P5 HANDWHEEL OPERATED WITH THRUST BEARINGS & RING JOINT GASKET BODY- BONNET CONNECTION

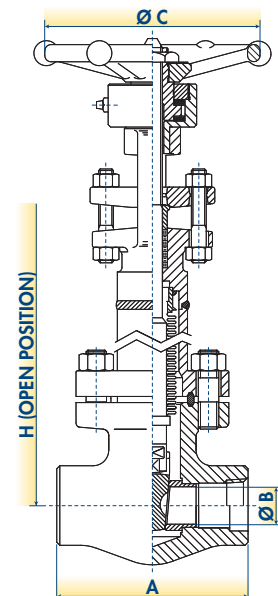

DESIGN TYPE P6 GEAR OPERATED & RING JOINT GASKET BODY-BONNET CONNECTION

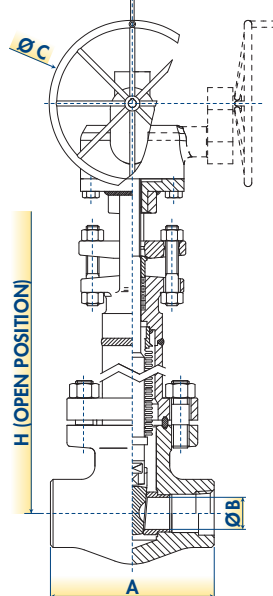

OTHER END CONNECTION TYPES AVAILABLE

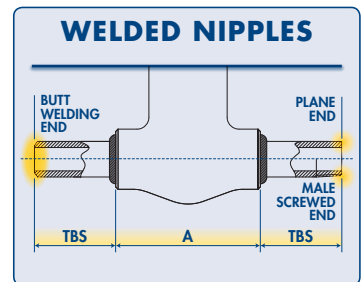
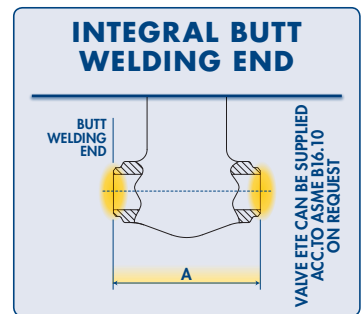

BOLTED BONNET GATE VALVES BELLOW SEAL CONFIGURATION ASME INTEGRAL FLANGED ENDS



WORKING PRESSURE RATING	SIZE		STANDARD DESIGN TYPE	A-RF		A-RJ		B		C		H		WEIGHT		FIGURE
	NPS	DN		mm	in	mm	in	mm	in	mm	in	mm	in	kg	lb	
ASME 150	1/2"	15	P4	108	4.25	N.A.	N.A.	9.6	0.38	88	3.5	193	7.6	5.2	11.6	1SL 103
	3/4"	20	P4	117	4.62	N.A.	N.A.	14	0.55	88	3.5	200	7.9	6.7	14.7	1SL 104
	1"	25	P4	127	5.00	140	5.00	18	0.71	97	3.8	233	9.2	9.4	20.7	1SL 105
	1-1/2"	40	P4	165	6.50	178	6.50	30	1.18	138	5.4	281	11.0	17.4	38.3	1SL 107
	2"	50	P4	178	7.00	191	7.00	37.5	1.47	138	5.4	319	12.6	23.9	52.6	1SL 108
ASME 300	1/2"	15	P4	140	5.50	151	5.50	9.6	0.38	88	3.5	193	7.6	6.5	14.3	3SL 103
	3/4"	20	P4	152	6.00	165	6.00	14	0.55	88	3.5	200	7.9	9.4	20.7	3SL 104
	1"	25	P4	165	6.50	178	6.50	18	0.71	97	3.8	233	9.2	12.1	26.7	3SL 105
	1-1/2"	40	P4	190	7.50	203	7.50	30	1.18	138	5.4	264	10.4	23.5	51.8	3SL 107
	2"	50	P4	216	8.50	232	8.50	37.5	1.47	138	5.4	319	12.6	27.7	61.0	3SL 108
ASME 600	1/2"	15	P4	165	6.50	163	6.50	9.6	0.38	88	3.5	175	6.9	7.8	17.1	6SL 103
	3/4"	20	P4	190	7.50	190	7.50	14	0.55	88	3.5	204	8.0	12.7	27.9	6SL 104
	1"	25	P4	216	8.50	216	8.50	18	0.71	97	3.8	237	9.3	18.1	39.9	6SL 105
	1-1/2"	40	P4	241	9.50	241	9.50	30	1.18	138	5.4	281	11.0	32.5	71.7	6SL 107
	2"	50	P4	292	11.50	295	11.50	37.5	1.47	138	5.4	336	13.2	50.6	111.6	6SL 108
ASME 1500	1/2"	15	P4	216	8.50	216	8.50	9.5	0.37	138	5.4	204	8.0	13.6	29.9	15SFL 103
	3/4"	20	P4	229	9.00	229	9.00	14	0.55	138	5.4	237	9.3	21.7	47.8	15SFL 104
	1"	25	P4	254	10.00	254	10.00	18	0.71	138	5.4	270	10.6	27.1	59.8	15SFL 105
	1-1/2"	40	P4	305	12.00	305	12.00	30	1.18	234	9.2	325	12.8	51.0	112.4	15SFL 107
	2"	50	P4	368	14.50	371.5	14.50	37.5	1.47	234	9.2	363	14.3	95.8	211.3	15SFL 108
ASME 150	1/2"	15	P4	108	4.25	N.A.	N.A.	14	0.55	88	3.5	193	7.6	5.8	12.8	1S 103
	3/4"	20	P4	117	4.62	N.A.	N.A.	18	0.71	97	3.8	231	9.1	8.5	18.7	1S 104
	1"	25	P4	127	5.00	140	5.00	24	0.94	138	5.4	253	10.0	11.0	24.3	1S 105
	1-1/2"	40	P4	165	6.50	178	6.50	37.5	1.47	138	5.4	319	12.6	20.6	45.4	1S 107
	2"	50	P4	178	7.00	191	7.00	48	1.89	172	6.8	374	14.7	32.5	71.7	1S 108
ASME 300	1/2"	15	P4	140	5.50	151	5.50	14	0.55	88	3.5	193	7.6	6.9	15.1	3S 103
	3/4"	20	P4	152	6.00	165	6.00	18	0.71	97	3.8	231	9.1	10.1	22.3	3S 104
	1"	25	P4	165	6.50	178	6.50	24	0.94	138	5.4	253	10.0	12.8	28.3	3S 105
	1-1/2"	40	P4	190	7.50	203	7.50	37.5	1.47	138	5.4	319	12.6	24.4	53.8	3S 107
	2"	50	P4	216	8.50	232	8.50	48	1.89	172	6.8	374	14.7	34.4	75.7	3S 108
ASME 600	1/2"	15	P4	165	6.50	163	6.50	14	0.55	88	3.5	193	7.6	7.8	17.1	6S 103
	3/4"	20	P4	190	7.50	190	7.50	18	0.71	97	3.8	237	9.3	12.7	27.9	6S 104
	1"	25	P4	216	8.50	216	8.50	24	0.94	138	5.4	264	10.4	18.1	39.9	6S 105
	1-1/2"	40	P4	241	9.50	241	9.50	37.5	1.47	138	5.4	325	12.8	32.5	71.7	6S 107
	2"	50	P4	292	11.50	295	11.50	48	1.89	172	6.8	396	15.6	50.6	111.6	6S 108
ASME 1500	1/2"	15	P4	216	8.50	216	8.50	14	0.55	138	5.4	237	9.3	14.8	32.7	15SF 103
	3/4"	20	P4	229	9.00	229	9.00	18	0.71	138	5.4	275	10.8	23.5	51.8	15SF 104
	1"	25	P4	254	10.00	254	10.00	24	0.94	172	6.8	297	11.7	29.3	64.6	15SF 105
	1-1/2"	40	P4	305	12.00	305	12.00	37.5	1.47	234	9.2	385	15.2	52.4	115.6	15SF 107
	2"	50	P4	368	14.50	371.5	14.50	48	1.89	320	12.6	490	19.3	99.4	219.2	15SF 108
ASME 2500	1/2"	15	P5	264	10.38	264	10.38	11.5	0.45	172	6.8	310	12.2	29.3	64.6	25SRF 103
	3/4"	20	P5	273	10.75	273	10.75	15	0.59	172	6.8	319	12.6	31.8	70.2	25SRF 104
	1"	25	P5	308	12.12	308	12.12	19.5	0.77	234	9.2	369	14.5	52.4	115.6	25SRF 105
	1-1/2"	40	P5	384	15.12	387	15.12	28	1.10	234	9.2	447	17.6	108.5	239.2	25SRF 107
	2"	50	P6	451	17.75	454	17.75	38	1.50	300	11.8	457	18.0	117.5	259.1	25SRF 108

STANDARD BORE

FULL BORE

B/E reserves the right to change designs, dimensions or specifications without notice.

PRODUCT FEATURES:

- Flanged ends acc.to ASME B16.5. • Face to Face acc.to ASME B16.10. • Zero emission. • Hydroformed Bellows • Extension-Bonnet weld acc.to ASME IX.
- Grease nipple for yoke sleeve. • Emergency stuffing box as back sealing.

DESIGN TYPE P4

HANDWHEEL OPERATED & SPIRAL WOUND GASKET BODY-BONNET CONNECTION

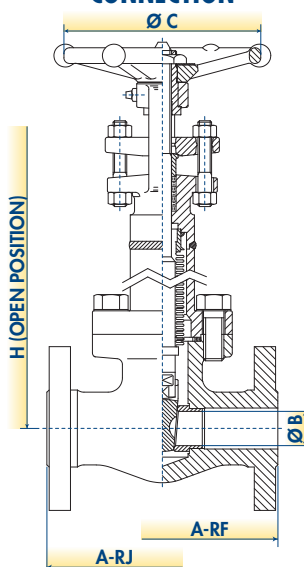

DESIGN TYPE P5

HANDWHEEL OPERATED WITH THRUST BEARINGS & RING JOINT GASKET BODY-BONNET CONNECTION

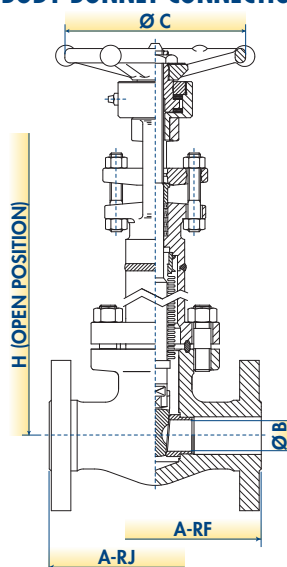

DESIGN TYPE P6

GEAR OPERATED & RING JOINT GASKET BODY-BONNET CONNECTION

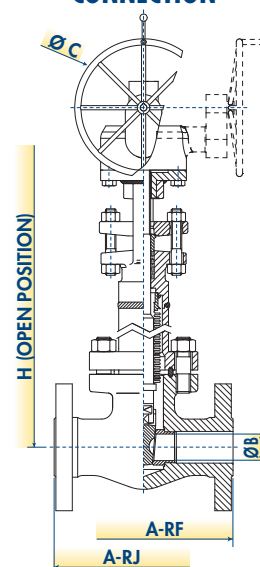

GATE VALVES

WELDED BONNET GATE VALVES BASIC CONFIGURATION THREADED AND SOCKET WELD ENDS



WORKING PRESSURE RATING	SIZE		STANDARD DESIGN TYPE	A		B		C		H		WEIGHT		FIGURE
	NPS	DN		mm	in	mm	in	mm	in	mm	in	kg	lb	
ASME 800	1/2"	15	W1	80	3.15	9.6	0.38	88	3.5	152	6.0	1.6	3.5	WL 103
	3/4"	20	W1	90	3.54	14	0.55	88	3.5	158	6.2	1.8	4.0	WL 104
	1"	25	W1	110	4.33	18	0.71	97	3.8	196	7.7	2.9	6.4	WL 105
	1-1/2"	40	W1	127	5.00	30	1.18	138	5.4	255	10.0	6.1	13.4	WL 107
	2"	50	W1	127	5.00	37.5	1.47	138	5.4	290	11.4	8.2	18.1	WL 108
ASME 1500	1/2"	15	W1	90	3.54	9.6	0.38	88	3.5	153	6.0	2	4.4	9WL 103
	3/4"	20	W1	110	4.33	14	0.55	97	3.8	190	7.5	3.3	7.3	9WL 104
	1"	25	W1	127	5.00	18	0.71	138	5.4	220	8.7	5.3	11.7	9WL 105
	1-1/2"	40	W1	127	5.00	30	1.18	138	5.4	282	11.1	9.8	21.6	9WL 107
	2"	50	W1	210	8.27	37.5	1.47	138	5.4	345	13.6	18.3	40.3	9WL 108
ASME 800	1/4"	6	W1	80	3.15	8	0.31	88	3.5	152	6.0	1.5	3.3	W 101
	3/8"	10	W1	80	3.15	9.6	0.38	88	3.5	152	6.0	1.5	3.3	W 102
	1/2"	15	W1	90	3.54	14	0.55	88	3.5	158	6.2	2	4.4	W 103
	3/4"	20	W1	110	4.33	18	0.71	97	3.8	196	7.7	3.5	7.7	W 104
	1"	25	W1	127	5.00	24	0.94	138	5.4	225	8.9	5	11.0	W 105
	1-1/4"	32	W1	127	5.00	30	1.18	138	5.4	255	10.0	6.5	14.3	W 106
	1-1/2"	40	W1	127	5.00	37.5	1.47	138	5.4	290	11.4	9.5	20.9	W 107
	2"	50	W1	210	8.27	50	1.96	172	6.8	358	14.1	16	35.3	W 108
ASME 1500	1/4"	6	W1	90	3.54	8	0.31	88	3.5	153	6.0	2	4.4	9W 101
	3/8"	10	W1	90	3.54	9.6	0.38	88	3.5	153	6.0	2	4.4	9W 102
	1/2"	15	W1	110	4.33	14	0.55	97	3.8	190	7.5	3.4	7.5	9W 103
	3/4"	20	W1	127	5.00	18	0.71	138	5.4	220	8.7	5.1	11.2	9W 104
	1"	25	W1	127	5.00	24	0.94	138	5.4	250	9.8	7	15.4	9W 105
	1-1/4"	32	W1	127	5.00	30	1.18	138	5.4	282	11.1	10	22.0	9W 106
	1-1/2"	40	W1	210	8.27	37.5	1.47	138	5.4	290	11.4	10.5	23.1	9W 107
	2"	50	W1	210	8.27	50	1.96	172	6.8	345	13.6	19	41.9	9W 108
ASME 2500	1/4"	6	W2	110	4.33	8	0.31	97	3.8	183	7.2	5.2	11.5	25W 101
	3/8"	10	W2	110	4.33	8	0.31	97	3.8	183	7.2	5.3	11.7	25W 102
	1/2"	15	W2	127	5.00	11.5	0.45	138	5.4	214	8.4	5.4	11.9	25W 103
	3/4"	20	W2	127	5.00	15	0.59	138	5.4	244	9.6	7.2	15.9	25W 104
	1"	25	W2	127	5.00	19.5	0.77	138	5.4	276	10.9	9.8	21.6	25W 105
	1-1/4"	32	W2	127	5.00	25	0.98	138	5.4	276	10.9	9.8	21.6	25W 106
	1-1/2"	40	W2	210	8.27	28	1.10	172	6.8	337	13.3	19.5	43.0	25W 107
	2"	50	W2	230	9.06	36	1.41	234	9.2	404	15.9	29	63.9	25W 108
ASME 4500	1/2"	15	W2	127	5.00	7.5	0.30	138	5.4	264	10.4	12	26.5	45W 103
	3/4"	20	W2	127	5.00	11.5	0.45	168	6.6	275	10.8	21	46.3	45W 104
	1"	25	W2	230	9.06	15	0.59	234	9.2	365	14.4	33	72.8	45W 105
	1-1/2"	40	W2	230	9.06	26	1.02	320	12.6	380	15.0	40	88.2	45W 107

STANDARD BORE

FULL BORE

BE reserves the right to change designs, dimensions or specifications without notice.

PRODUCT FEATURES:

- Socket Weld acc.to ASME B16.11. • Screwed ends (NPT) acc.to ASME B1.20.1. • Butt welding ends acc.to ASME B16.25. • End to End acc.to manufacturer standard. • Body-Bonnet weld acc.to ASME IX.

DESIGN TYPE W1 V-GROOVE SEAL WELD BODY-BONNET CONNECTION

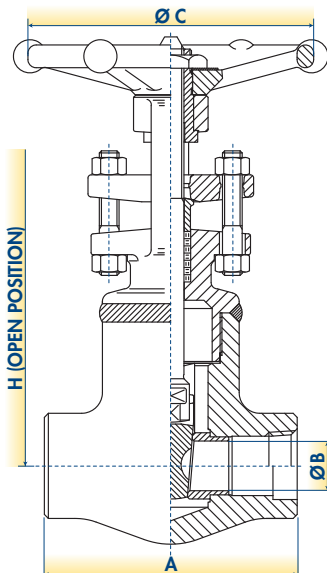

DESIGN TYPE W2 TEE JOINT FILLET WELD BODY-BONNET CONNECTION

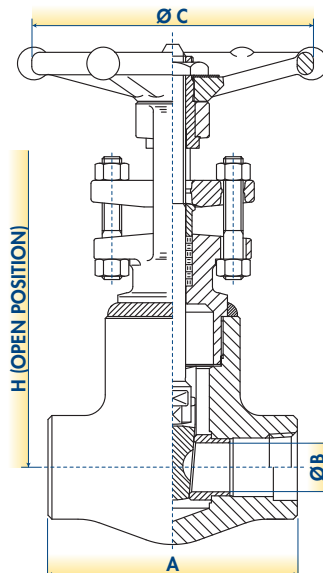

OTHER END CONNECTION TYPES AVAILABLE

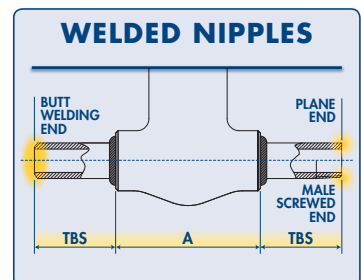
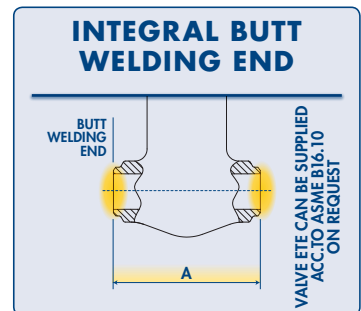

WELDED BONNET GATE VALVES BASIC CONFIGURATION ASME INTEGRAL FLANGED ENDS



WORKING PRESSURE RATING	SIZE		STANDARD DESIGN TYPE	A-RF		A-RJ		B		C		H		WEIGHT		FIGURE
	NPS	DN		mm	in	mm	in	mm	in	mm	in	mm	in	kg	lb	
ASME 150	1/2"	15	W3	108	4.25	N.A.	N.A.	9.6	0.38	88	3.5	152	6.0	4.1	9.0	1HWL 103
	3/4"	20	W3	117	4.62	N.A.	N.A.	14	0.55	88	3.5	158	6.2	5.2	11.4	1HWL 104
	1"	25	W3	127	5.00	140	5.00	18	0.71	97	3.8	196	7.7	7.3	16.0	1HWL 105
	1-1/2"	40	W3	165	6.50	178	6.50	30	1.18	138	5.4	255	10.0	13.4	29.6	1HWL 107
	2"	50	W3	178	7.00	191	7.00	37.5	1.47	138	5.4	290	11.4	18.5	40.7	1HWL 108
ASME 300	1/2"	15	W3	140	5.50	151	5.50	9.6	0.38	88	3.5	152	6.0	5.0	11.1	3HWL 103
	3/4"	20	W3	152	6.00	165	6.00	14	0.55	88	3.5	158	6.2	7.3	16.0	3HWL 104
	1"	25	W3	165	6.50	178	6.50	18	0.71	97	3.8	196	7.7	9.4	20.7	3HWL 105
	1-1/2"	40	W3	190	7.50	203	7.50	30	1.18	138	5.4	255	10.0	18.2	40.1	3HWL 107
	2"	50	W3	216	8.50	232	8.50	37.5	1.47	138	5.4	290	11.4	21.4	47.2	3HWL 108
ASME 600	1/2"	15	W3	165	6.50	163	6.50	9.6	0.38	88	3.5	152	6.0	6.0	13.3	6HWL 103
	3/4"	20	W3	190	7.50	190	7.50	14	0.55	88	3.5	158	6.2	9.8	21.6	6HWL 104
	1"	25	W3	216	8.50	216	8.50	18	0.71	97	3.8	196	7.7	14.0	30.9	6HWL 105
	1-1/2"	40	W3	241	9.50	241	9.50	30	1.18	138	5.4	255	10.0	25.2	55.6	6HWL 107
	2"	50	W3	292	11.50	295	11.50	37.5	1.47	138	5.4	290	11.4	39.2	86.4	6HWL 108
ASME 1500	1/2"	15	W3	216	8.50	216	8.50	9.5	0.37	88	3.5	153	6.0	10.5	23.1	15HWLF 103
	3/4"	20	W3	229	9.00	229	9.00	14	0.55	97	3.8	190	7.5	16.8	37.0	15HWLF 104
	1"	25	W3	254	10.00	254	10.00	18	0.71	138	5.4	220	8.7	21.0	46.3	15HWLF 105
	1-1/2"	40	W3	305	12.00	305	12.00	30	1.18	172	6.8	282	11.1	39.5	87.0	15HWLF 107
	2"	50	W3	368	14.50	371.5	14.50	37.5	1.47	172	6.8	345	13.6	74.2	163.6	15HWLF 108
ASME 150	1/2"	15	W3	108	4.25	N.A.	N.A.	14	0.55	88	3.5	158	6.2	4.5	9.9	1HW 103
	3/4"	20	W3	117	4.62	N.A.	N.A.	18	0.71	97	3.8	196	7.7	6.6	14.5	1HW 104
	1"	25	W3	127	5.00	140	5.00	24	0.94	138	5.4	225	8.9	8.5	18.8	1HW 105
	1-1/2"	40	W3	165	6.50	178	6.50	37.5	1.47	138	5.4	290	11.4	16.0	35.2	1HW 107
	2"	50	W3	178	7.00	191	7.00	48	1.89	172	6.8	358	14.1	25.2	55.6	1HW 108
ASME 300	1/2"	15	W3	140	5.50	151	5.50	14	0.55	88	3.5	158	6.2	5.3	11.7	3HW 103
	3/4"	20	W3	152	6.00	165	6.00	18	0.71	97	3.8	196	7.7	7.8	17.3	3HW 104
	1"	25	W3	165	6.50	178	6.50	24	0.94	138	5.4	225	8.9	9.9	21.9	3HW 105
	1-1/2"	40	W3	190	7.50	203	7.50	37.5	1.47	138	5.4	290	11.4	18.9	41.7	3HW 107
	2"	50	W3	216	8.50	232	8.50	48	1.89	172	6.8	358	14.1	26.6	58.6	3HW 108
ASME 600	1/2"	15	W3	165	6.50	163	6.50	14	0.55	88	3.5	158	6.2	6.0	13.3	6HW 103
	3/4"	20	W3	190	7.50	190	7.50	18	0.71	97	3.8	196	7.7	9.8	21.6	6HW 104
	1"	25	W3	216	8.50	216	8.50	24	0.94	138	5.4	225	8.9	14.0	30.9	6HW 105
	1-1/2"	40	W3	241	9.50	241	9.50	37.5	1.47	138	5.4	290	11.4	25.2	55.6	6HW 107
	2"	50	W3	292	11.50	295	11.50	48	1.89	172	6.8	358	14.1	39.2	86.4	6HW 108
ASME 1500	1/2"	15	W3	216	8.50	216	8.50	14	0.55	97	3.8	190	7.5	11.5	25.3	15HWF 103
	3/4"	20	W3	229	9.00	229	9.00	18	0.71	138	5.4	220	8.7	18.2	40.1	15HWF 104
	1"	25	W3	254	10.00	254	10.00	24	0.94	138	5.4	250	9.8	22.7	50.0	15HWF 105
	1-1/2"	40	W3	305	12.00	305	12.00	37.5	1.47	172	6.8	290	11.4	40.6	89.5	15HWF 107
	2"	50	W3	368	14.50	371.5	14.50	48	1.89	234	9.2	345	13.6	77.0	169.8	15HWF 108
ASME 2500	1/2"	15	W3	264	10.38	264	10.38	11.5	0.45	138	5.4	214	8.4	22.7	50.0	25HWF 103
	3/4"	20	W3	273	10.75	273	10.75	15	0.59	138	5.4	244	9.6	24.6	54.3	25HWF 104
	1"	25	W3	308	12.12	308	12.12	19.5	0.77	172	6.8	276	10.9	40.6	89.5	25HWF 105
	1-1/2"	40	W3	384	15.12	387	15.12	28	1.10	234	9.2	337	13.3	84.0	185.2	25HWF 107
	2"	50	W3	451	17.75	454	17.75	38	1.50	320	12.6	404	15.9	91.0	200.6	25HWF 108

STANDARD BORE

FULL BORE

BFE reserves the right to change designs, dimensions or specifications without notice.

PRODUCT FEATURES:

- Flanged ends acc.to ASME B16.5. • Face to Face acc.to ASME B16.10. • Body-Bonnet weld acc.to ASME IX.

DESIGN TYPE W3

FULL PENETRATION WELD BODY-BONNET CONNECTION

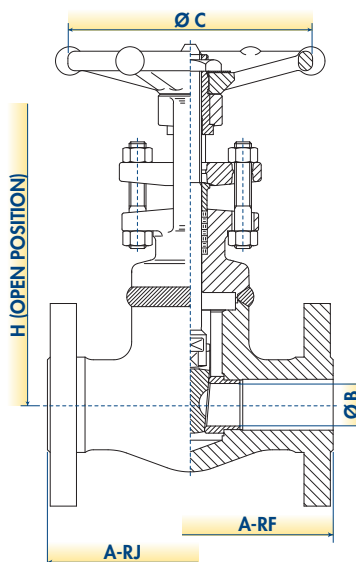

GATE VALVES

WELDED BONNET GATE VALVES CRYOGENIC CONFIGURATION THREADED AND SOCKET WELD ENDS



WORKING PRESSURE RATING	SIZE		STANDARD DESIGN TYPE	A		B		C		H		WEIGHT		FIGURE
	NPS	DN		mm	in	mm	in	mm	in	mm	in	kg	lb	
ASME 800	1/2"	15	W1	80	3.15	9.6	0.38	88	3.5	406	16.0	2.4	5.3	CWL 103
	3/4"	20	W1	90	3.54	14	0.55	88	3.5	412	16.2	2.7	6.0	CWL 104
	1"	25	W1	110	4.33	18	0.71	97	3.8	450	17.7	4.4	9.6	CWL 105
	1-1/2"	40	W1	127	5.00	30	1.18	138	5.4	509	20.0	9.2	20.2	CWL 107
	2"	50	W1	127	5.00	37.5	1.47	138	5.4	544	21.4	12.3	27.1	CWL 108
ASME 1500	1/2"	15	W1	90	3.54	9.6	0.38	88	3.5	407	16.0	3.0	6.6	9CWL 103
	3/4"	20	W1	110	4.33	14	0.55	97	3.8	444	17.5	5.0	10.9	9CWL 104
	1"	25	W1	127	5.00	18	0.71	138	5.4	474	18.7	8.0	17.5	9CWL 105
	1-1/2"	40	W1	127	5.00	30	1.18	138	5.4	536	21.1	14.7	32.4	9CWL 107
	2"	50	W1	210	8.27	37.5	1.47	138	5.4	599	23.6	27.5	60.5	9CWL 108
ASME 800	1/4"	6	W1	80	3.15	8	0.31	88	3.5	406	16.0	2.3	5.0	CW 101
	3/8"	10	W1	80	3.15	9.6	0.38	88	3.5	406	16.0	2.3	5.0	CW 102
	1/2"	15	W1	90	3.54	14	0.55	88	3.5	412	16.2	3.0	6.6	CW 103
	3/4"	20	W1	110	4.33	18	0.71	97	3.8	450	17.7	5.3	11.6	CW 104
	1"	25	W1	127	5.00	24	0.94	138	5.4	479	18.9	7.5	16.5	CW 105
	1-1/4"	32	W1	127	5.00	30	1.18	138	5.4	509	20.0	9.8	21.5	CW 106
	1-1/2"	40	W1	127	5.00	37.5	1.47	138	5.4	544	21.4	14.3	31.4	CW 107
2"	50	W1	210	8.27	50	1.96	172	6.8	612	24.1	24.0	52.9	CW 108	
ASME 1500	1/4"	6	W1	90	3.54	8	0.31	88	3.5	407	16.0	3.0	6.6	9CW 101
	3/8"	10	W1	90	3.54	9.6	0.38	88	3.5	407	16.0	3.0	6.6	9CW 102
	1/2"	15	W1	110	4.33	14	0.55	97	3.8	444	17.5	5.1	11.2	9CW 103
	3/4"	20	W1	127	5.00	18	0.71	138	5.4	474	18.7	7.7	16.9	9CW 104
	1"	25	W1	127	5.00	24	0.94	138	5.4	504	19.8	10.5	23.1	9CW 105
	1-1/4"	32	W1	127	5.00	30	1.18	138	5.4	536	21.1	15.0	33.1	9CW 106
	1-1/2"	40	W1	210	8.27	37.5	1.47	138	5.4	544	21.4	15.8	34.7	9CW 107
2"	50	W1	210	8.27	50	1.96	172	6.8	599	23.6	28.5	62.8	9CW 108	
ASME 2500	1/4"	6	W2	110	4.33	8	0.31	97	3.8	437	17.2	7.8	17.2	25CW 101
	3/8"	10	W2	110	4.33	8	0.31	97	3.8	437	17.2	8.0	17.5	25CW 102
	1/2"	15	W2	127	5.00	11.5	0.45	138	5.4	468	18.4	8.1	17.9	25CW 103
	3/4"	20	W2	127	5.00	15	0.59	138	5.4	498	19.6	10.8	23.8	25CW 104
	1"	25	W2	127	5.00	19.5	0.77	138	5.4	530	20.9	14.7	32.4	25CW 105
	1-1/4"	32	W2	127	5.00	25	0.98	138	5.4	530	20.9	14.7	32.4	25CW 106
	1-1/2"	40	W2	210	8.27	28	1.10	172	6.8	591	23.3	29.3	64.5	25CW 107
2"	50	W2	230	9.06	36	1.41	234	9.2	658	25.9	43.5	95.9	25CW 108	
ASME 4500	1/2"	15	W2	127	5.00	7.5	0.30	138	5.4	518	20.4	18.0	39.7	45CW 103
	3/4"	20	W2	127	5.00	11.5	0.45	168	6.6	529	20.8	31.5	69.4	45CW 104
	1"	25	W2	230	9.06	15	0.59	234	9.2	619	24.4	49.5	109.1	45CW 105
	1-1/2"	40	W2	230	9.06	26	1.02	320	12.6	634	25.0	60.0	132.3	45CW 107

STANDARD BORE

FULL BORE

BFE reserves the right to change designs, dimensions or specifications without notice.

PRODUCT FEATURES:

- Socket Weld acc. to ASME B16.11. • Screwed ends (NPT) acc. to ASME B1.20.1. • Butt welding ends acc. to ASME B16.25. • End to End acc. to manufacturer standard. • Cryogenic design acc. to BS 6364. • Body-Bonnet weld acc. to ASME IX. • Body Cavity Vent Hole.

DESIGN TYPE W1 V-GROOVE SEAL WELD BODY-BONNET CONNECTION

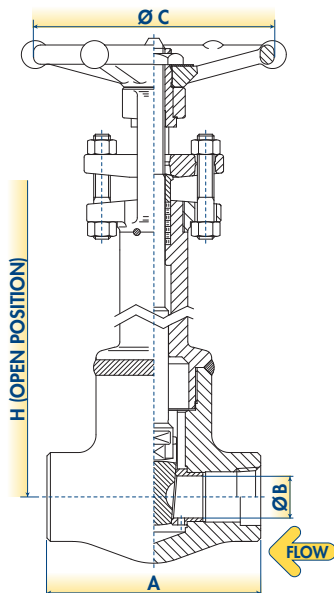

DESIGN TYPE W2 TEE JOINT FILLET WELD BODY-BONNET CONNECTION

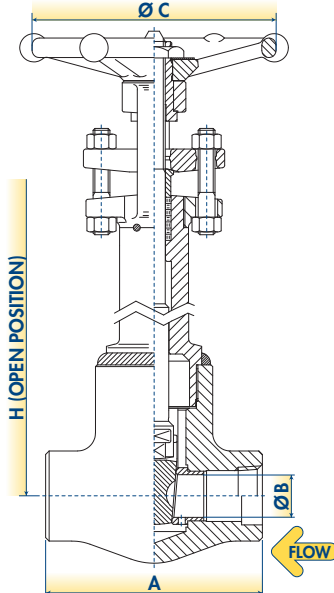

OTHER END CONNECTION TYPES AVAILABLE

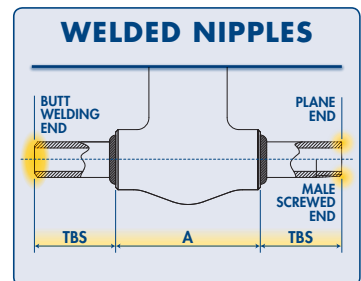
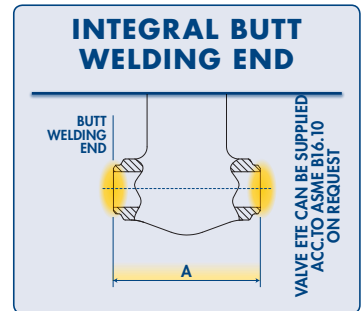

WELDED BONNET GATE VALVES CRYOGENIC CONFIGURATION ASME INTEGRAL FLANGED ENDS



WORKING PRESSURE RATING	SIZE		STANDARD DESIGN TYPE	A-RF		A-RJ		B		C		H		WEIGHT		FIGURE
	NPS	DN		mm	in	mm	in	mm	in	mm	in	mm	in	kg	lb	
ASME 150	1/2"	15	W3	108	4.25	N.A.	N.A.	9.6	0.38	88	3.5	406	16.0	5.9	13.0	1CHWL 103
	3/4"	20	W3	117	4.62	N.A.	N.A.	14	0.55	88	3.5	412	16.2	7.5	16.6	1CHWL 104
	1"	25	W3	127	5.00	140	5.00	18	0.71	97	3.8	450	17.7	10.6	23.3	1CHWL 105
	1-1/2"	40	W3	165	6.50	178	6.50	30	1.18	138	5.4	509	20.0	19.5	43.0	1CHWL 107
	2"	50	W3	178	7.00	191	7.00	37.5	1.47	138	5.4	544	21.4	26.8	59.1	1CHWL 108
ASME 300	1/2"	15	W3	140	5.50	151	5.50	9.6	0.38	88	3.5	406	16.0	7.3	16.1	3CHWL 103
	3/4"	20	W3	152	6.00	165	6.00	14	0.55	88	3.5	412	16.2	10.6	23.3	3CHWL 104
	1"	25	W3	165	6.50	178	6.50	18	0.71	97	3.8	450	17.7	13.6	30.0	3CHWL 105
	1-1/2"	40	W3	190	7.50	203	7.50	30	1.18	138	5.4	509	20.0	26.4	58.2	3CHWL 107
	2"	50	W3	216	8.50	232	8.50	37.5	1.47	138	5.4	544	21.4	31.1	68.5	3CHWL 108
ASME 600	1/2"	15	W3	165	6.50	163	6.50	9.6	0.38	88	3.5	406	16.0	8.7	19.2	6CHWL 103
	3/4"	20	W3	190	7.50	190	7.50	14	0.55	88	3.5	412	16.2	14.2	31.3	6CHWL 104
	1"	25	W3	216	8.50	216	8.50	18	0.71	97	3.8	450	17.7	20.3	44.8	6CHWL 105
	1-1/2"	40	W3	241	9.50	241	9.50	30	1.18	138	5.4	509	20.0	36.5	80.6	6CHWL 107
	2"	50	W3	292	11.50	295	11.50	37.5	1.47	138	5.4	544	21.4	56.8	125.3	6CHWL 108
ASME 1500	1/2"	15	W3	216	8.50	216	8.50	9.5	0.37	88	3.5	407	16.0	15.2	33.6	15CHWLF 103
	3/4"	20	W3	229	9.00	229	9.00	14	0.55	97	3.8	444	17.5	24.4	53.7	15CHWLF 104
	1"	25	W3	254	10.00	254	10.00	18	0.71	138	5.4	474	18.7	30.5	67.1	15CHWLF 105
	1-1/2"	40	W3	305	12.00	305	12.00	30	1.18	172	6.8	536	21.1	57.2	126.2	15CHWLF 107
	2"	50	W3	368	14.50	371.5	14.50	37.5	1.47	172	6.8	599	23.6	107.6	237.2	15CHWLF 108
ASME 150	1/2"	15	W3	108	4.25	N.A.	N.A.	14	0.55	88	3.5	412	16.2	6.5	14.3	1CHW 103
	3/4"	20	W3	117	4.62	N.A.	N.A.	18	0.71	97	3.8	450	17.7	9.5	21.0	1CHW 104
	1"	25	W3	127	5.00	140	5.00	24	0.94	138	5.4	479	18.9	12.4	27.3	1CHW 105
	1-1/2"	40	W3	165	6.50	178	6.50	37.5	1.47	138	5.4	544	21.4	23.1	51.0	1CHW 107
	2"	50	W3	178	7.00	191	7.00	48	1.89	172	6.8	612	24.1	36.5	80.6	1CHW 108
ASME 300	1/2"	15	W3	140	5.50	151	5.50	14	0.55	88	3.5	412	16.2	7.7	17.0	3CHW 103
	3/4"	20	W3	152	6.00	165	6.00	18	0.71	97	3.8	450	17.7	11.4	25.1	3CHW 104
	1"	25	W3	165	6.50	178	6.50	24	0.94	138	5.4	479	18.9	14.4	31.8	3CHW 105
	1-1/2"	40	W3	190	7.50	203	7.50	37.5	1.47	138	5.4	544	21.4	27.4	60.4	3CHW 107
	2"	50	W3	216	8.50	232	8.50	48	1.89	172	6.8	612	24.1	38.6	85.0	3CHW 108
ASME 600	1/2"	15	W3	165	6.50	163	6.50	14	0.55	88	3.5	412	16.2	8.7	19.2	6CHW 103
	3/4"	20	W3	190	7.50	190	7.50	18	0.71	97	3.8	450	17.7	14.2	31.3	6CHW 104
	1"	25	W3	216	8.50	216	8.50	24	0.94	138	5.4	479	18.9	20.3	44.8	6CHW 105
	1-1/2"	40	W3	241	9.50	241	9.50	37.5	1.47	138	5.4	544	21.4	36.5	80.6	6CHW 107
	2"	50	W3	292	11.50	295	11.50	48	1.89	172	6.8	612	24.1	56.8	125.3	6CHW 108
ASME 1500	1/2"	15	W3	216	8.50	216	8.50	14	0.55	97	3.8	444	17.5	16.6	36.7	15CHWF 103
	3/4"	20	W3	229	9.00	229	9.00	18	0.71	138	5.4	474	18.7	26.4	58.2	15CHWF 104
	1"	25	W3	254	10.00	254	10.00	24	0.94	138	5.4	504	19.8	32.9	72.5	15CHWF 105
	1-1/2"	40	W3	305	12.00	305	12.00	37.5	1.47	172	6.8	544	21.4	58.9	129.8	15CHWF 107
	2"	50	W3	368	14.50	371.5	14.50	48	1.89	234	9.2	599	23.6	111.7	246.1	15CHWF 108
ASME 2500	1/2"	15	W3	264	10.38	264	10.38	11.5	0.45	138	5.4	468	18.4	32.9	72.5	25CHWF 103
	3/4"	20	W3	273	10.75	273	10.75	15	0.59	138	5.4	498	19.6	35.7	78.8	25CHWF 104
	1"	25	W3	308	12.12	308	12.12	19.5	0.77	172	6.8	530	20.9	58.9	129.8	25CHWF 105
	1-1/2"	40	W3	384	15.12	387	15.12	28	1.10	234	9.2	591	23.3	121.8	268.5	25CHWF 107
	2"	50	W3	451	17.75	454	17.75	38	1.50	320	12.6	658	25.9	132.0	290.9	25CHWF 108

STANDARD BORE

FULL BORE

BFE reserves the right to change designs, dimensions or specifications without notice.

PRODUCT FEATURES:

- Flanged ends acc.to ASME B16.5. • Face to Face acc.to ASME B16.10. • Cryogenic design acc.to BS 6364. • Body-Bonnet weld acc.to ASME IX. • Body Cavity Vent Hole.

DESIGN TYPE W3

FULL PENETRATION WELD BODY-BONNET CONNECTION

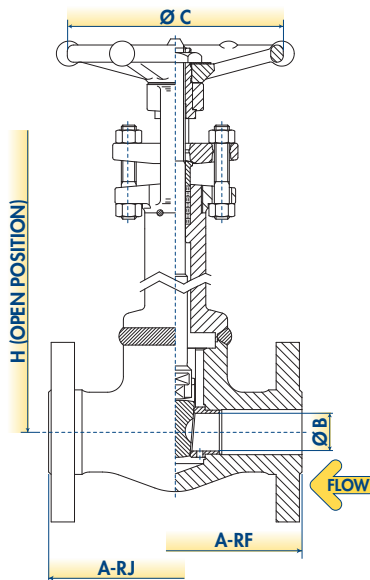

GATE VALVES

WELDED BONNET GATE VALVES BELLOW SEAL CONFIGURATION THREADED AND SOCKET WELD ENDS



WORKING PRESSURE RATING	SIZE		STANDARD DESIGN TYPE	A		B		C		H		WEIGHT		FIGURE
	NPS	DN		mm	in	mm	in	mm	in	mm	in	kg	lb	
ASME 800	1/2"	15	P1	80	3.15	9.6	0.38	88	3.5	230	9.1	2.1	4.6	SHWL 103
	3/4"	20	P1	90	3.54	14	0.55	88	3.5	234	9.2	2.4	5.3	SHWL 104
	1"	25	P1	110	4.33	18	0.71	97	3.8	285	11.2	3.9	8.6	SHWL 105
	1-1/2"	40	P1	127	5.00	30	1.18	138	5.4	370	14.6	8.6	19.0	SHWL 107
	2"	50	P1	127	5.00	37.5	1.47	138	5.4	435	17.1	11	24.3	SHWL 108
ASME 1500	1/2"	15	P1	90	3.54	9.6	0.38	138	5.4	238	9.4	2.8	6.2	9SHWL 103
	3/4"	20	P1	110	4.33	14	0.55	138	5.4	293	11.5	4.6	10.1	9SHWL 104
	1"	25	P1	127	5.00	18	0.71	138	5.4	343	13.5	6.5	14.3	9SHWL 105
	1-1/2"	40	P1	127	5.00	30	1.18	234	9.2	450	17.7	9	19.8	9SHWL 107
	2"	50	P1	210	8.27	37.5	1.47	234	9.2	588	23.1	22	48.5	9SHWL 108
ASME 800	1/4"	6	P1	80	3.15	8	0.31	88	3.5	230	9.1	2.3	5.1	SHW 101
	3/8"	10	P1	80	3.15	9.6	0.38	88	3.5	230	9.1	2.3	5.1	SHW 102
	1/2"	15	P1	90	3.54	14	0.55	88	3.5	234	9.2	2.5	5.5	SHW 103
	3/4"	20	P1	110	4.33	18	0.71	97	3.8	285	11.2	3.8	8.4	SHW 104
	1"	25	P1	127	5.00	24	0.94	138	5.4	325	12.8	6.2	13.7	SHW 105
	1-1/4"	32	P1	127	5.00	30	1.18	138	5.4	370	14.6	8.4	18.5	SHW 106
	1-1/2"	40	P1	127	5.00	37.5	1.47	138	5.4	435	17.1	11.2	24.7	SHW 107
	2"	50	P1	210	8.27	50	1.96	172	6.8	530	20.9	20	44.1	SHW 108
ASME 1500	1/2"	15	P1	110	4.33	14	0.55	138	5.4	293	11.5	4.5	9.9	9SHW 103
	3/4"	20	P1	127	5.00	18	0.71	138	5.4	343	13.5	6.5	14.3	9SHW 104
	1"	25	P1	127	5.00	24	0.94	172	6.8	388	15.3	8.3	18.3	9SHW 105
	1-1/2"	40	P1	210	8.27	37.5	1.47	234	9.2	588	23.1	22	48.5	9SHW 107
ASME 2500	1/2"	15	P2	127	5.00	11.5	0.45	172	6.8	430	16.9	6.5	14.3	25SHW 103
	3/4"	20	P2	127	5.00	15	0.59	172	6.8	450	17.7	6.5	14.3	25SHW 104
	1"	25	P2	127	5.00	19.5	0.77	234	9.2	510	20.1	16	35.3	25SHW 105
	1-1/2"	40	P2	210	8.27	28	1.10	234	9.2	630	24.8	29	63.9	25SHW 107
	2"	50	P3	230	9.06	35	1.38	300	11.8	880	34.6	45	99.2	25SHW 108

STANDARD BORE

FULL BORE

BFE reserves the right to change designs, dimensions or specifications without notice.

PRODUCT FEATURES:

- Socket Weld acc.to ASME B16.11. • Screwed ends (NPT) acc.to ASME B1.20.1. • Butt welding ends acc.to ASME B16.25. • End to End acc.to manufacturer standard. • Zero emission. • Hydroformed Bellows
- Welds acc.to ASME IX. • Grease nipple for yoke sleeve. • Emergency stuffing box as back sealing.

DESIGN TYPE P1 HANDWHEEL OPERATED

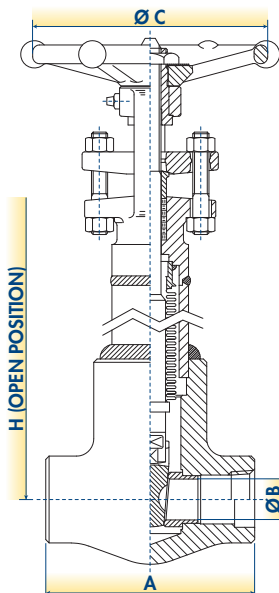

DESIGN TYPE P2 HANDWHEEL OPERATED WITH THRUST BEARINGS

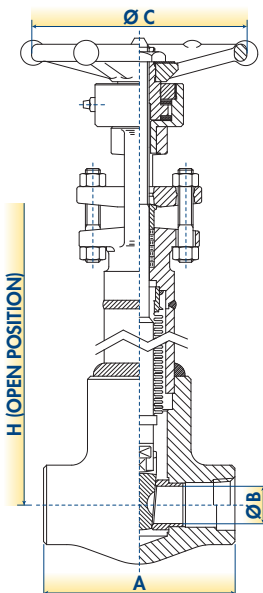

DESIGN TYPE P3 GEAR OPERATED

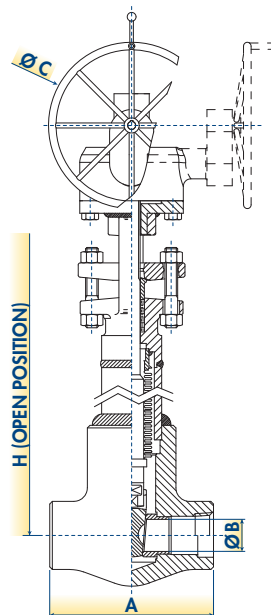

OTHER END CONNECTION TYPES AVAILABLE

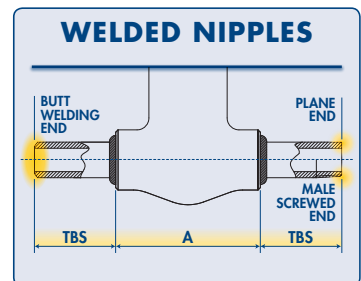
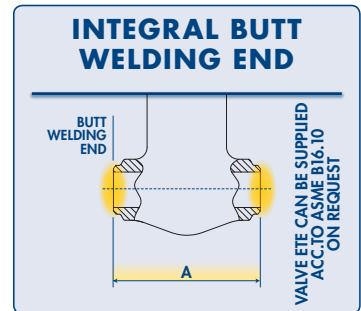

WELDED BONNET GATE VALVES BELLOW SEAL CONFIGURATION ASME INTEGRAL FLANGED ENDS



WORKING PRESSURE RATING	SIZE		STANDARD DESIGN TYPE	A-RF		A-RJ		B		C		H		WEIGHT		FIGURE
	NPS	DN		mm	in	mm	in	mm	in	mm	in	mm	in	kg	lb	
ASME 150	1/2"	15	P1	108	4.25	N.A.	N.A.	9.6	0.38	88	3.5	193	7.6	4.6	10.2	1SHWL 103
	3/4"	20	P1	117	4.62	N.A.	N.A.	14	0.55	88	3.5	200	7.9	5.9	13.1	1SHWL 104
	1"	25	P1	127	5.00	140	5.50	18	0.71	97	3.8	233	9.2	8.3	18.3	1SHWL 105
	1-1/2"	40	P1	165	6.50	178	7.00	30	1.18	138	5.4	281	11.0	15.4	33.9	1SHWL 107
	2"	50	P1	178	7.00	191	7.50	37.5	1.47	138	5.4	319	12.6	21.1	46.6	1SHWL 108
ASME 300	1/2"	15	P1	140	5.50	151	5.94	9.6	0.38	88	3.5	193	7.6	5.8	12.7	3SHWL 103
	3/4"	20	P1	152	6.00	165	6.50	14	0.55	88	3.5	200	7.9	8.3	18.3	3SHWL 104
	1"	25	P1	165	6.50	178	7.00	18	0.71	97	3.8	233	9.2	10.7	23.6	3SHWL 105
	1-1/2"	40	P1	190	7.50	203	8.00	30	1.18	138	5.4	264	10.4	20.8	45.9	3SHWL 107
	2"	50	P1	216	8.50	232	9.12	37.5	1.47	138	5.4	319	12.6	24.5	54.0	3SHWL 108
ASME 600	1/2"	15	P1	165	6.50	163	6.44	9.6	0.38	88	3.5	175	6.9	6.9	15.2	6SHWL 103
	3/4"	20	P1	190	7.50	190	7.50	14	0.55	88	3.5	204	8.0	11.2	24.7	6SHWL 104
	1"	25	P1	216	8.50	216	8.50	18	0.71	97	3.8	237	9.3	16.0	35.3	6SHWL 105
	1-1/2"	40	P1	241	9.50	241	9.50	30	1.18	138	5.4	281	11.0	28.8	63.5	6SHWL 107
	2"	50	P1	292	11.50	295	11.62	37.5	1.47	138	5.4	336	13.2	44.8	98.8	6SHWL 108
ASME 1500	1/2"	15	P1	216	8.50	216	8.50	9.5	0.37	138	5.4	204	8.0	12.0	26.5	15SHWLF 103
	3/4"	20	P1	229	9.00	229	9.00	14	0.55	138	5.4	237	9.3	19.2	42.3	15SHWLF 104
	1"	25	P1	254	10.00	254	10.00	18	0.71	138	5.4	270	10.6	24.0	52.9	15SHWLF 105
	1-1/2"	40	P1	305	12.00	305	12.00	30	1.18	234	9.2	325	12.8	45.1	99.5	15SHWLF 107
	2"	50	P1	368	14.50	371.5	14.62	37.5	1.47	234	9.2	363	14.3	84.8	187.0	15SHWLF 108
ASME 150	1/2"	15	P1	108	4.25	N.A.	N.A.	14	0.55	88	3.5	193	7.6	5.1	11.3	1SHW 103
	3/4"	20	P1	117	4.62	N.A.	N.A.	18	0.71	97	3.8	231	9.1	7.5	16.6	1SHW 104
	1"	25	P1	127	5.00	140	5.50	24	0.94	138	5.4	253	10.0	9.8	21.5	1SHW 105
	1-1/2"	40	P1	165	6.50	178	7.00	37.5	1.47	138	5.4	319	12.6	18.2	40.2	1SHW 107
	2"	50	P1	178	7.00	191	7.50	48	1.89	172	6.8	374	14.7	28.8	63.5	1SHW 108
ASME 300	1/2"	15	P1	140	5.50	151	5.94	14	0.55	88	3.5	193	7.6	6.1	13.4	3SHW 103
	3/4"	20	P1	152	6.00	165	6.50	18	0.71	97	3.8	231	9.1	9.0	19.8	3SHW 104
	1"	25	P1	165	6.50	178	7.00	24	0.94	138	5.4	253	10.0	11.4	25.0	3SHW 105
	1-1/2"	40	P1	190	7.50	203	8.00	37.5	1.47	138	5.4	319	12.6	21.6	47.6	3SHW 107
	2"	50	P1	216	8.50	232	9.12	48	1.89	172	6.8	374	14.7	30.4	67.0	3SHW 108
ASME 600	1/2"	15	P1	165	6.50	163	6.44	14	0.55	88	3.5	193	7.6	6.9	15.2	6SHW 103
	3/4"	20	P1	190	7.50	190	7.50	18	0.71	97	3.8	237	9.3	11.2	24.7	6SHW 104
	1"	25	P1	216	8.50	216	8.50	24	0.94	138	5.4	264	10.4	16.0	35.3	6SHW 105
	1-1/2"	40	P1	241	9.50	241	9.50	37.5	1.47	138	5.4	325	12.8	28.8	63.5	6SHW 107
	2"	50	P1	292	11.50	295	11.62	48	1.89	172	6.8	396	15.6	44.8	98.8	6SHW 108
ASME 1500	1/2"	15	P1	216	8.50	216	8.50	14	0.55	138	5.4	237	9.3	13.1	28.9	15SHWF 103
	3/4"	20	P1	229	9.00	229	9.00	18	0.71	138	5.4	275	10.8	20.8	45.9	15SHWF 104
	1"	25	P1	254	10.00	254	10.00	24	0.94	172	6.8	297	11.7	25.9	57.1	15SHWF 105
	1-1/2"	40	P1	305	12.00	305	12.00	37.5	1.47	234	9.2	385	15.2	46.4	102.3	15SHWF 107
	2"	50	P1	368	14.50	371.5	14.62	48	1.89	320	12.6	490	19.3	88.0	194.0	15SHWF 108
ASME 2500	1/2"	15	P2	264	10.38	264	10.38	11.5	0.45	172	6.8	310	12.2	25.9	57.1	25SHWF 103
	3/4"	20	P2	273	10.75	273	10.75	15	0.59	172	6.8	319	12.6	28.2	62.1	25SHWF 104
	1"	25	P2	308	12.12	308	12.12	19.5	0.77	234	9.2	369	14.5	46.4	102.3	25SHWF 105
	1-1/2"	40	P2	384	15.12	387	15.24	28	1.10	234	9.2	447	17.6	96.0	211.6	25SHWF 107
	2"	50	P3	451	17.75	454	17.87	38	1.50	300	11.8	457	18.0	104.0	229.3	25SHWF 108

STANDARD BORE

FULL BORE

B/E reserves the right to change designs, dimensions or specifications without notice.

PRODUCT FEATURES:

- Flanged ends acc. to ASME B16.5. • Face to Face acc. to ASME B16.10. • Zero emission. • Hydroformed Bellows. • Welds acc. to ASME IX. • Grease nipple for yoke sleeve. • Emergency stuffing box as back sealing.

**DESIGN TYPE P1
HANDWHEEL OPERATED**

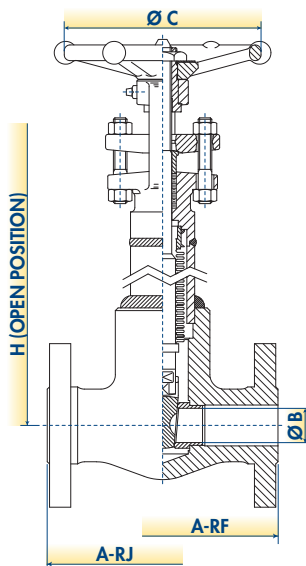

**DESIGN TYPE P2
HANDWHEEL OPERATED WITH THRUST BEARINGS**

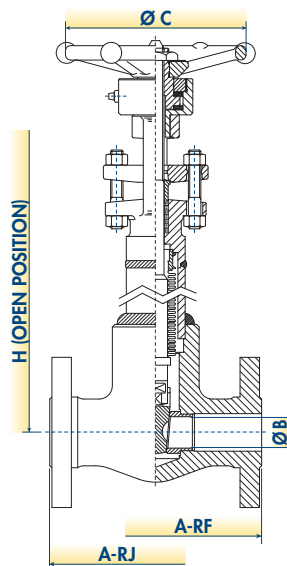

**DESIGN TYPE P3
GEAR OPERATED**

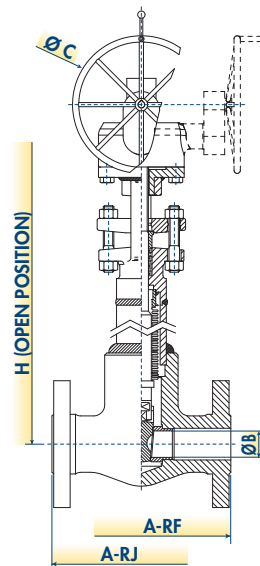

GATE VALVES

BOLTED BONNET GATE VALVES INTEGRAL REINFORCED EXTENDED BODY CONFIGURATION VALVOLET AND LIP ENDS VALVES



SPL

SPL

WORKING PRESSURE RATING	SIZE		STANDARD DESIGN TYPE	A		B		C		H		D1		D2		D3		L1		L2		WEIGHT		FIGURE LIP	FIGURE VALVOLET
	NPS	DN		mm	in	mm	in	mm	in	mm	in	mm	in	mm	in	mm	in	mm	in	kg	lb				
ASME 800	1/2"	15	E1	207	8.15	9.6	0.38	88	3.5	152	6.0	17.5	0.69	22	0.9	N.A.	N.A.	167	6.6	4	0.16	2.6	5.7	VLL 103	VL 103
	3/4"	20	E1	218.5	8.60	14	0.55	88	3.5	158	6.2	22	0.87	30	1.2	N.A.	N.A.	173	6.8	4.8	0.19	3.1	6.8	VLL 104	VL 104
	1"	25	E1	244.5	9.63	18	0.71	97	3.8	196	7.7	28.5	1.12	36.5	1.4	N.A.	N.A.	190	7.5	4.8	0.19	5.1	11.2	VLL 105	VL 105
	1-1/2"	40	E1	263.5	10.37	30	1.18	138	5.4	255	10.0	41	1.61	50.5	2.0	N.A.	N.A.	200	7.9	6.3	0.25	9.5	20.9	VLL 107	VL 107
	2"	50	E1	267.5	10.53	36.6	1.44	138	5.4	290	11.4	46	1.81	65	2.6	N.A.	N.A.	204	8.0	8	0.31	13	28.7	VLL 108	VL 108
ASME 1500	1/2"	15	E1	218.5	8.60	9.6	0.38	88	3.5	153	6.0	17.5	0.69	30	1.2	N.A.	N.A.	173	6.8	4	0.16	3.6	7.9	9VLL 103	9VL 103
	3/4"	20	E1	244.5	9.63	14	0.55	97	3.8	190	7.5	22	0.87	36.5	1.4	N.A.	N.A.	190	7.5	4.8	0.19	5.6	12.3	9VLL 104	9VL 104
	1"	25	E1	263.5	10.37	18	0.71	138	5.4	220	8.7	28.5	1.12	50.5	2.0	N.A.	N.A.	200	7.9	4.8	0.19	10.5	23.1	9VLL 105	9VL 105
	1-1/2"	40	E1	267.5	10.53	30	1.18	138	5.4	282	11.1	41	1.61	65	2.6	N.A.	N.A.	204	8.0	6.3	0.25	14.5	32.0	9VLL 107	9VL 107

STANDARD BORE

PRODUCT FEATURES:

- Socket Weld acc.to ASME B16.11. • Screwed ends (NPT) acc.to ASME B1.20.1. • Butt welding ends acc.to ASME B16.25. • End to End acc.to manufacturer standard.

BOLTED BONNET GATE VALVES EXTENDED BODY CONFIGURATION THREADED AND WELDING ENDS VALVES



SPL



WORKING PRESSURE RATING	SIZE		STANDARD DESIGN TYPE	A		B		C		H		D1		D2		D3		L1		WEIGHT		FIGURE SOCKET	FIGURE WELDING	FIGURE MALE THREADED
	NPS	DN		mm	in	mm	in	mm	in	mm	in	mm	in	mm	in	mm	in	kg	lb					
ASME 800	1/2"	15	E2	141.5	5.57	9.6	0.38	88	3.5	152	6.0	21.3	0.8	13	0.5	23	0.91	102	4.0	2.4	5.3	MLT 103	MLB 103	MLF 103
	3/4"	20	E2	146.5	5.77	14	0.55	88	3.5	158	6.2	26.7	1.1	16	0.6	28	1.10	102	4.0	2.6	5.7	MLT 104	MLB 104	MLF 104
	1"	25	E2	166	6.54	18	0.71	97	3.8	196	7.7	33.4	1.3	21	0.8	36	1.42	111	4.4	4.2	9.3	MLT 105	MLB 105	MLF 105
	1-1/2"	40	E2	190.5	7.50	30	1.18	138	5.4	255	10.0	48.3	1.9	34	1.3	52	2.05	127	5.0	8.1	17.9	MLT 107	MLB 107	MLF 107
	2"	50	E2	216	8.50	36.6	1.44	138	5.4	290	11.4	60.3	2.4	42	1.7	62	2.44	153	6.0	11.8	26.0	MLT 108	MLB 108	MLF 108
ASME 1500	1/2"	15	E2	146.5	5.77	9.6	0.38	88	3.5	153	6.0	21.3	0.8	13	0.5	23	0.91	102	4.0	2.6	5.7	9MLT 103	9MLB 103	9MLF 103
	3/4"	20	E2	166	6.54	14	0.55	97	3.8	190	7.5	26.7	1.1	16	0.6	28	1.10	111	4.4	4.6	10.1	9MLT 104	9MLB 104	9MLF 104
	1"	25	E2	190.5	7.50	18	0.71	138	5.4	220	8.7	33.4	1.3	21	0.8	36	1.42	127	5.0	9.1	20.1	9MLT 105	9MLB 105	9MLF 105
	1-1/2"	40	E2	216	8.50	30	1.18	138	5.4	282	11.1	48.3	1.9	34	1.3	52	2.05	153	6.0	13	28.7	9MLT 107	9MLB 107	9MLF 107

STANDARD BORE

PRODUCT FEATURES:

- Socket Weld acc.to ASME B16.11. • Screwed ends (NPT) acc.to ASME B1.20.1. • Butt welding ends acc.to ASME B16.25. • End to End acc.to manufacturer standard.

DESIGN TYPE E1

IINTEGRAL REINFORCED EXTENDED BODY SPIRAL WOUND BODY-BONNET CONNECTION

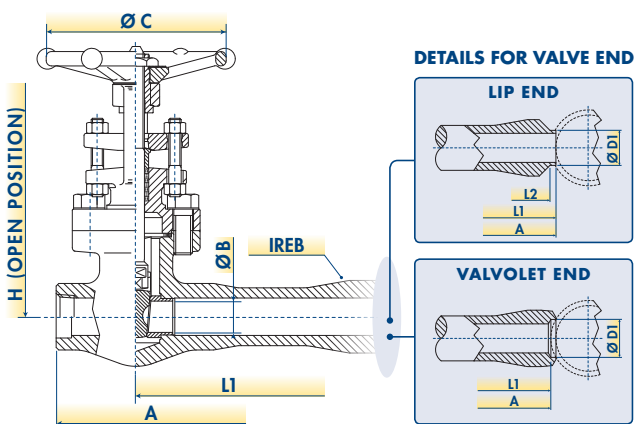

DESIGN TYPE E2

EXTENDED BODY SPIRAL WOUND BODY-BONNET CONNECTION

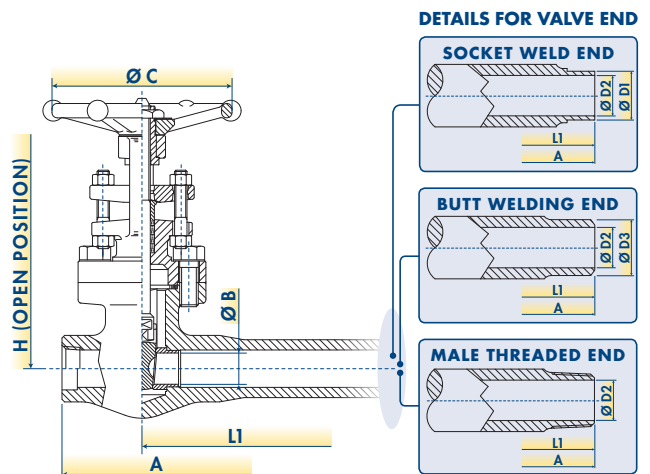

BFE reserves the right to change designs, dimensions or specifications without notice.

WELDED BONNET GATE VALVES INTEGRAL REINFORCED EXTENDED BODY CONFIGURATION VALVOLET AND LIP ENDS VALVES



SPL

SPL

WORKING PRESSURE RATING	SIZE		STANDARD DESIGN TYPE	A		B		C		H		D1		D2		D3		L1		L2		WEIGHT		FIGURE LIP	FIGURE VALVOLET	STANDARD BORE
	NPS	DN		mm	in	mm	in	mm	in	mm	in	mm	in	mm	in	mm	in	mm	in	mm	in	kg	lb			
ASME 800	1/2"	15	E3	207	8.15	9.6	0.38	88	3.5	152	6.0	17.5	0.69	22	0.9	N.A.	N.A.	167	6.6	4	0.16	2.3	5.1	VOL 103	VOLL 103	
	3/4"	20	E3	218.5	8.60	14	0.55	88	3.5	158	6.2	22	0.87	30	1.2	N.A.	N.A.	173	6.8	4.8	0.19	2.9	6.4	VOL 104	VOLL 104	
	1"	25	E3	244.5	9.63	18	0.71	97	3.8	196	7.7	28.5	1.12	36.5	1.4	N.A.	N.A.	190	7.5	4.8	0.19	4.3	9.5	VOL 105	VOLL 105	
	1-1/2"	40	E3	263.5	10.37	30	1.18	138	5.4	255	10.0	41	1.61	50.5	2.0	N.A.	N.A.	200	7.9	6.3	0.25	8.8	19.4	VOL 107	VOLL 107	
	2"	50	E3	267.5	10.53	36.6	1.44	138	5.4	290	11.4	46	1.81	65	2.6	N.A.	N.A.	204	8.0	8	0.31	11.7	25.8	VOL 108	VOLL 108	
ASME 1500	1/2"	15	E3	218.5	8.60	9.6	0.38	88	3.5	153	6.0	17.5	0.69	30	1.2	N.A.	N.A.	173	6.8	4	0.16	2.9	6.4	9VOL 103	9VOLL 103	
	3/4"	20	E3	244.5	9.63	14	0.55	97	3.8	190	7.5	22	0.87	36.5	1.4	N.A.	N.A.	190	7.5	4.8	0.19	4.7	10.4	9VOL 104	9VOLL 104	
	1"	25	E3	263.5	10.37	18	0.71	138	5.4	220	8.7	28.5	1.12	50.5	2.0	N.A.	N.A.	200	7.9	4.8	0.19	9	19.8	9VOL 105	9VOLL 105	
	1-1/2"	40	E3	267.5	10.53	30	1.18	138	5.4	282	11.1	41	1.61	65	2.6	N.A.	N.A.	204	8.0	6.3	0.25	12.5	27.6	9VOL 107	9VOLL 107	

PRODUCT FEATURES:

- Socket Weld acc.to ASME B16.11. • Screwed ends (NPT) acc.to ASME B1.20.1. • Butt welding ends acc.to ASME B16.25. • End to End acc.to manufacturer standard. • Body-Bonnet weld acc.to ASME IX.

WELDED BONNET GATE VALVES EXTENDED BODY CONFIGURATION THREADED AND WELDING ENDS VALVES



SPL



WORKING PRESSURE RATING	SIZE		STANDARD DESIGN TYPE	A		B		C		H		D1		D2		D3		L1		WEIGHT		FIGURE SOCKET	FIGURE WELDING	FIGURE MALE THREADED	STANDARD BORE
	NPS	DN		mm	in	mm	in	mm	in	mm	in	mm	in	mm	in	mm	in	mm	in	kg	lb				
ASME 800	1/2"	15	E4	141.5	5.57	9.6	0.38	88	3.5	152	6.0	21.3	0.8	13	0.5	23	0.91	102	4.0	1.7	3.7	MFLT 103	MFLB 103	MFLF 103	
	3/4"	20	E4	146.5	5.77	14	0.55	88	3.5	158	6.2	26.7	1.1	16	0.6	28	1.10	102	4.0	2.1	4.6	MFLT 104	MFLB 104	MFLF 104	
	1"	25	E4	166	6.54	18	0.71	97	3.8	196	7.7	33.4	1.3	21	0.8	36	1.42	111	4.4	3.2	7.1	MFLT 105	MFLB 105	MFLF 105	
	1-1/2"	40	E4	190.5	7.50	30	1.18	138	5.4	255	10.0	48.3	1.9	34	1.3	52	2.05	127	5.0	7.2	15.9	MFLT 107	MFLB 107	MFLF 107	
	2"	50	E4	216	8.50	36.6	1.44	138	5.4	290	11.4	60.3	2.4	42	1.7	62	2.44	153	6.0	10.3	22.7	MFLT 108	MFLB 108	MFLF 108	
ASME 1500	1/2"	15	E4	146.5	5.77	9.6	0.38	88	3.5	153	6.0	21.3	0.8	13	0.5	23	0.91	102	4.0	2.1	4.6	9MFLT 103	9MFLB 103	9MFLF 103	
	3/4"	20	E4	166	6.54	14	0.55	97	3.8	190	7.5	26.7	1.1	16	0.6	28	1.10	111	4.4	3.8	8.4	9MFLT 104	9MFLB 104	9MFLF 104	
	1"	25	E4	190.5	7.50	18	0.71	138	5.4	220	8.7	33.4	1.3	21	0.8	36	1.42	127	5.0	8.1	17.9	9MFLT 105	9MFLB 105	9MFLF 105	
	1-1/2"	40	E4	216	8.50	30	1.18	138	5.4	282	11.1	48.3	1.9	34	1.3	52	2.05	153	6.0	12	26.5	9MFLT 107	9MFLB 107	9MFLF 107	

PRODUCT FEATURES:

- Socket Weld acc.to ASME B16.11. • Screwed ends (NPT) acc.to ASME B1.20.1. • Butt welding ends acc.to ASME B16.25. • End to End acc.to manufacturer standard. • Body-Bonnet weld acc.to ASME IX.

DESIGN TYPE E3

INTEGRAL REINFORCED EXTENDED BODY V-GROOVE SEAL WELD BODY-BONNET

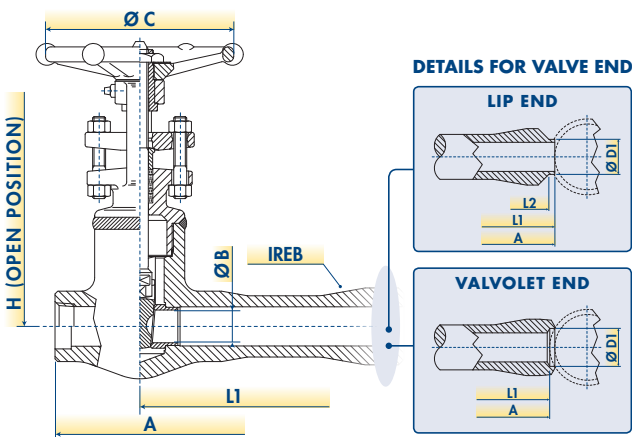

DESIGN TYPE E4

EXTENDED BODY V-GROOVE SEAL WELD BODY-BONNET CONNECTION

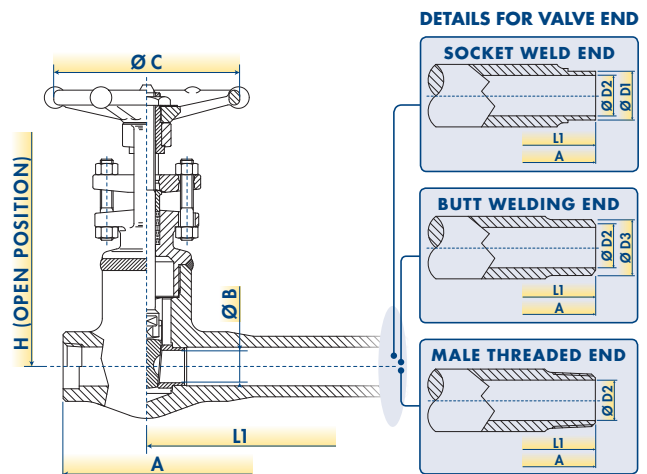

BFE reserves the right to change designs, dimensions or specifications without notice.

AVAILABLE OPTIONS FOR GATE VALVES

OTHER VALVE OPTIONS OR CUSTOMIZED VERSIONS ARE AVAILABLE ON REQUEST, CONTACT BFE FOR SPECIAL REQUIREMENTS.

STEM EXTENSION

Valve handle can be extended to allow for panel mount and pipe insulation.

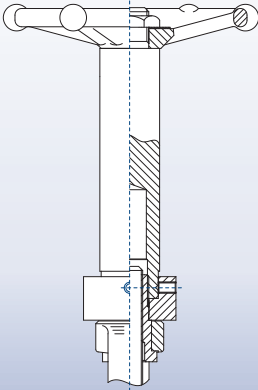

POSITION INDICATOR

Valves can be supplied with standard visual-mechanical indicating device that also acts as stem cover.

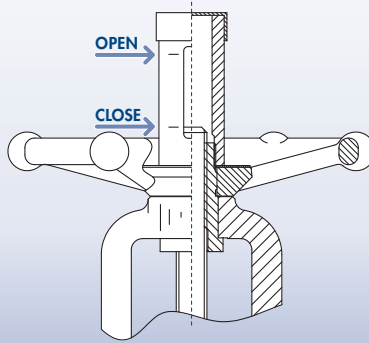

BEVEL GEAR OPERATOR

Gearing can be applied to valves instead of the standard handwheel to make operation easier.

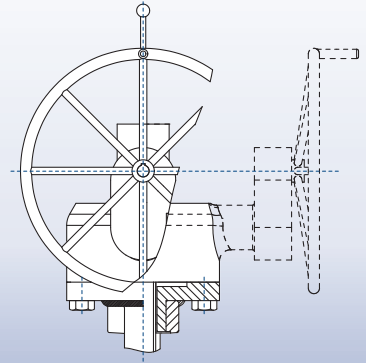

ELECTRIC, PNEUMATIC OR HYDRAULIC ACTUATORS

Motorized controls may be applied to valves of any size for operation in any position or location.

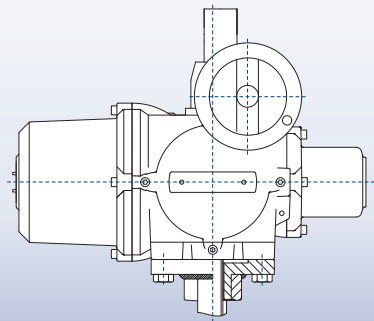

ACTUATOR-READY

Valves can be supplied ready for actuation without the handwheel or gear box. The mounting connection can be BFE Standard or can suit the choice or type of actuator.

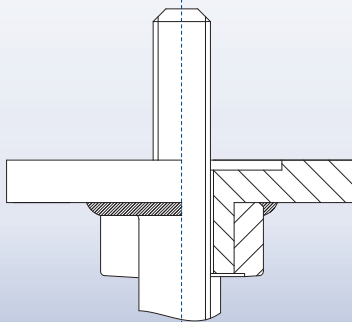

OVERPRESSURE DEVICE

Cavity over-pressurization protection can be supplied. BFE standard option is a hole performed on the seat, if required the same hole can be performed on the closure member.

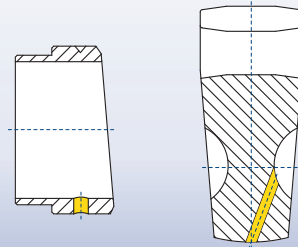

LOCKING DEVICE

Locking devices designed to help prevent accidental or unwanted operation are built to resist excessive force. All BFE locking device options are simple but secure. Chain and Padlock available on request.

LOCKING FACILITY

LOCKING FACILITY WITH C&P

LOCKING DEVICE

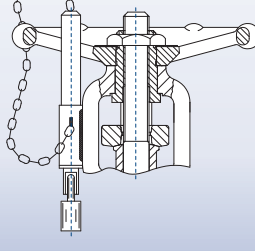
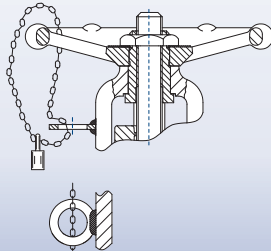
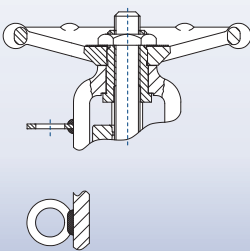

THERMAL EXPANSION STEM COMPENSATOR

Valves which endure large thermal transients have the basic problem that the valve stem and closure member will expand and contract with the danger that a closed valve could become jammed in its seat and in extreme cases this can cause the valve stem to distort. High Temperature Valve configuration is equipped with a spring loaded stem sleeve that will absorb any expansion or contraction caused by temperature fluctuations without affecting the position of the closed valve stem.

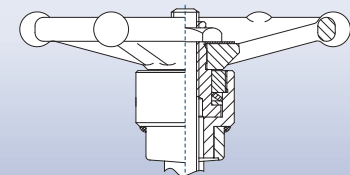

AVAILABLE OPTIONS FOR GATE VALVES

OTHER VALVE OPTIONS OR CUSTOMIZED VERSIONS ARE AVAILABLE ON REQUEST, CONTACT BFE FOR SPECIAL REQUIREMENTS.

CLOSURE MEMBER TYPE OTHER THAN SOLID WEDGE

The flex wedge

is a one piece, fully guided cast wedge with a central hub to allow the seating faces to move relative to each other thus compensating for distortion of the body seats due to thermal expansion or piping loads.

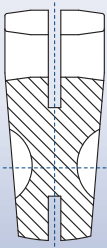

The split wedge

is self-adjusting to both seal sides and consists of two-piece construction. This type of wedge is suitable for the treatment of non-condensing gases and liquids at normal temperatures, particularly corrosive liquids.

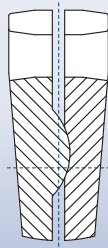

Parallel seat gate

and seat ring construction can be furnished for high differential pressure services where stem low torque is required or where high piping loads or thermal expansion may cause sticking of a wedge type gate. Spring-loaded discs are self-aligning and reduces actuator torque requirements.

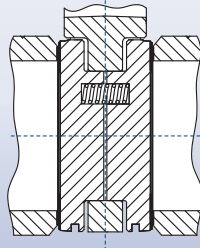

SPECIAL END FINISH

The choice of end connections for connecting a valve to its associated pipe is performed by customers. Common end finish stated in the catalogue are socket, threaded, flanged (RF or RJ) and butt-weld ends. BFE is basically able to perform any end finish as required by the customers and other end finish as follows: hub, compact flange, any ASME B16.5 end finish other than RF and RJ, etc.

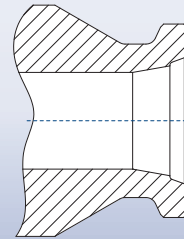

STEM DOUBLE SEAL

Stem double seals are fitted to valves when hazardous fluids are handled or when external lubrication is used. The most usual form of double seal is two sets of packing, the lantern ring can provide extra stem guidance. BFE can supply the lantern ring version with standard plug or with injector (double ball check type). Other special configurations are available on request.

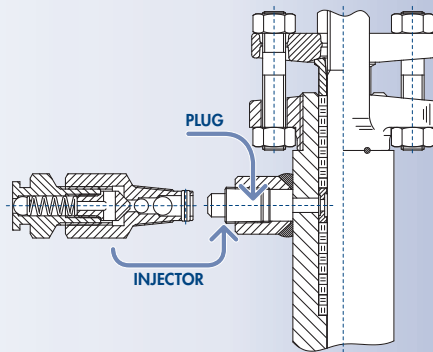

LIMIT SWITCH ASSEMBLIES

Position Limit Switch assemblies enables a remote signaling of the control system the opening of the valve. It can be equipped with one or two switches actuated by closing or opening of the valve. Limit switch can be selected by customer, bracket is designed by BFE.

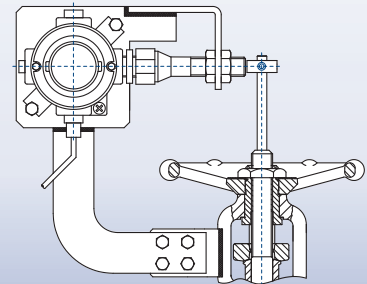

BODY-BONNET FULL PENETRATION WELD

BFE standard welded bonnet valves have as standard a seal weld on the body-bonnet connection. Seal weld is a weld that does not contribute anything to the mechanical integrity of an assembly, but is made purely to seal or prevent leakage from, for instance, a threaded joint. When High-End quality is required for body-bonnet weld joint a weld with full penetration can be performed. Full penetration weld is one in which there is a complete penetration and fusion of weld and parent metal throughout the thickness of the joint. A full penetration weld ensures a fully welded interface between the two parts and is generally the strongest joint.

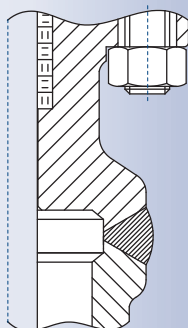

LIVE LOADING

Live Loading System consists of a spring system installed on packing stud to warrant a continuous load on valve packing. Spring are specially designed to allow appropriate load in case of packing settling by minimizing initial load and friction. Mechanical visual indicator of the spring compression is included.

