

# Gator Utility Vehicles

Take the “heavy” out of heavy work



JOHN DEERE



## Feel the difference

Mud soaked trails...impossibly steep inclines... freezing cold starts...John Deere Gators have proved themselves year after year as go-anywhere, dependable and reliable work vehicles. With more than 500,000 built, they've earned a reputation for durability and quality like no other.

Fun to drive. Practical to use. You won't find a wider choice of utility vehicles to meet your needs. You don't have to take our word for it either. Take a ride. Feel the difference!



## 7 good reasons to go for a Gator utility vehicle

# 1

### **Simplicity itself.**

With just two pedals, the Gator utility vehicle is here to make your life easier. The intuitive controls also mean you needn't worry about any unexpected surprises.

# 2

### **Efficiency? You got it!**

The new Deluxe Cargo Box is packed to the brim with fantastic features. More space, easy operation and a whole host of handy functions guarantee the ultimate in efficiency.

# 3

### **Tested to the very limit.**

Like all our machines, the Gator utility vehicle can't go anywhere until it's passed some seriously tough tests. The new XUV's survived over 20,000 hours of blistering real world testing in one of the harshest environments in the United States.





4

**Technology to rely on.**

Great dynamics, economical consumption, quiet operation, low emissions – the list is endless. The continuously variable transmission ensures you always stay right on track.

6

**The softly, softly approach.**

We know beautiful grass requires gentle care and attention. That's why the tyres on our Gator utility vehicle models tread just as softly as you do.

5

**More comfort is a safe bet.**

Fully-hydraulic disc brakes, one-piece frame, 4-wheel suspension and low load height – just some examples that show it doesn't get safer or more comfortable than with the Gator utility vehicle.

7

**There's always room for more!**

Blade, windshield...and even an electric power lift. With a dizzying selection of practical attachments and accessories, there's almost no limit to what your Gator utility vehicle can do!

# Looking for...

## Work Utility Vehicles



### ...small but powerful?

Compact Series	
Gator CX	6
<ul style="list-style-type: none"> <li>• Wide, low cargo bed</li> <li>• Compact dimensions</li> <li>• Perfect for tight spaces</li> </ul>	
<p>The name says it all! This little bundle of energy will take you anywhere, weaving its way easily through parks and landscaped areas dotted with trees and flower beds. And, while it may be compact, it packs as much power and comfort as its larger cousins.</p>	

### ...getting the job done?

Traditional Series	
Gator TS	8
Gator TX & TX Turf	10
Gator TE (electric)	12
Gator TH 6x4 Diesel	14
<ul style="list-style-type: none"> <li>• Unibody frame</li> <li>• Wide, low cargo bed</li> <li>• Extremely turf-friendly</li> <li>• Low centre of gravity</li> </ul>	
<p>The “workhorses” of the Traditional Series give you extreme efficiency and safety – without compromising on comfort and ease of operation. And because these hard-working vehicles are surprisingly light on their toes, it’s good news all round for your grass, too.</p>	

### ...outstanding potential?

High Performance Series	
Gator HPX 4x4	16
<ul style="list-style-type: none"> <li>• Hydro formed steel frame</li> <li>• Powerful 854 cm<sup>3</sup> diesel engine</li> <li>• “True” four-wheel drive</li> <li>• Full vehicle suspension</li> <li>• Tackles any terrain</li> </ul>	
<p>Whether hilly ground or muddy tracks, no terrain is too rugged for the Gator 4x4 utility vehicle in the High Performance Series. It’s a safe, reliable partner for even the toughest tasks. When other vehicles run out of steam, this Gator utility vehicle is just getting going.</p>	

**Cross-Over Utility Vehicles**



**Heavy-Duty Utility Vehicles**



**Accessories**



**...ultimate performance?**

<b>Ultimate Series</b>	
Gator XUV 855 Diesel	18
<ul style="list-style-type: none"> <li>• “True” 4-Wheel Drive</li> <li>• Independent suspension</li> <li>• Top speed of 52 km/h</li> <li>• The ultimate on and off-road vehicle</li> </ul>	
<p>Over hill and dale, rough and smooth – the Gator XUV in the Ultimate Series will take you anywhere you need to go! With true 4-wheel drive, speed sensing power steering and an impressive turn of speed, this vehicle can conquer virtually any obstacle with ease.</p>	

**...maximum versatility?**

<b>Professional Series</b>	
ProGator	22
<ul style="list-style-type: none"> <li>• 7-gauge, formed-steel frame</li> <li>• Wide, low cargo bed</li> <li>• A pro on golf courses and sports fields</li> </ul>	
<p>This model is simply unbeatable when it comes to professional turf care on golf courses and sports fields. Whether you’re spraying, top dressing or collecting turf debris, the ProGator utility vehicle is always at home.</p>	

**...that special something extra?**

Cabs & canopies	24
Accessories	25
Attachments	28
Tyres	29
Specifications	30
Parts & Merchandising	33

 Key features

 Key specs

 Recommended applications



## Gator CX

The solution that gets you out of any tight spot

The compact Gator CX is unbeatable for negotiating narrow paths and tight tracks or weaving your way through shrubs and bushes. This type of terrain brings out the best in this little trooper.

If space is at a premium but you don't want to sacrifice the diversity and quality you've come to expect from John Deere, this compact all-rounder is the perfect choice!



### Trim lines

With perfect proportions of just 1.2 x 2.5 m, the Gator CX can squeeze through even the narrowest spaces.



### Punching above its weight

Get ready to experience full-on power from this compact model!



**Still want more? No problem.**

With a range of practical attachments, your Gator CX can tackle any task.



✓	Compact size
	Comfortable low load height
	Twin bucket seats
	Excellent ride quality
	Differential lock
	Handy divider slots and tie-down attaching points help you organise your cargo

⚙️	Engine 9.5 hp
	Velocity 0-24 km/h / (0-15 mp/h)
	Load capacity 363 kg

🌿	Parks
	Cemeteries
	Golf courses



# Gator TS

Let's get started





Got a load of over 400 kg? No problem. Let the Gator TS take the strain – powered by a 350 cc petrol engine combined with a surprisingly light footprint on turf.

But that’s not all. With its exceptional stability, intuitive operation, rugged steel cargo box and tiltable tailgate, the Gator TS delivers the ultimate in smooth efficiency!

**A fast mover**

Even when fully loaded, the Gator TS reaches speeds of up to 32 km/h.



**Safe. Solid. Superb.**

The one-piece frame, direct rack-and-pinion steering, ground-hugging centre of gravity and standard differential lock keeps the TS Gator going even in rough conditions!

✓	Comfortable low load height
	Low centre of gravity
	Exceptional ease of use
	High flotation tyres

⚙️	Engine 9.5 hp
	Velocity 0-32 km/h (0-20 mp/h)
	Load capacity 408 kg

🌿	Fine turf applications
	Nurseries
	Leisure parks
	Parks

## Gator TX & TX Turf

### A load off your mind

More power and acceleration combined with even more comfort for you? Sounds impossible? Think again. Our Gator TX & TX Turf delivers both! A powerful 2-cylinder engine (TX) and payload capacity of 454 kg transform these models into veritable powerhouses. Plus these powerful vehicles have a gentle touch, ensuring they also go easy on the grass.



**Polyurea spray-in bed liner**  
protects the durable steel floor against scratches and corrosion.

**20 tie-down points**  
let you secure cargo better than shrink wrap.



**Cargo box side extension**  
Four-sided structure that increases cargo box side height to 610 mm and doubles the volume up to 920 l.

Option



**Flat bed**  
Cargo box sides can be removed in minutes to convert the box to a flat bed.



**Divider**  
lets you arrange your working tools in a proper way.

Option



**Tailgate**  
Pick-up style tailgate folds out to 90 degrees and down a full 150 degrees. The latch can be operated with one hand.



**Zero handicaps**

A practical foot pedal start, quiet operation and high flotation turf tyres that are kind to the turf mean the Gator TX Turf has really earned its golfing stripes.



✓	2-Cylinder petrol engine
	Low centre of gravity
	4-wheel suspension
	Deluxe Cargo Box
	All wheel disc brakes

⚙️	Engine 17 hp (TX) / 11 hp (TX Turf)
	Velocity TX 0-32 km/h (0-20 mp/h)
	TX Turf 0-25 km/h (0-15.5 mp/h)
	Load capacity 454 kg

🌿	Golf courses
	Fine turf applications
	Nurseries
	Leisure parks
	Parks

## Gator TE

Clean up your act with zero emissions

Golf courses, work premises or even enclosed spaces – the Gator TE has what it takes where being green matters and where quiet, emission-free operation is the order of the day.

With a long pedigree of impressive credentials – including powerful batteries, rapid torque rise and the new multi-function Deluxe Cargo Box – the Gator TE means you can now opt for an electric drive without compromising on power.



### Supreme staying power

Thanks to its 8 super-strength batteries, the Gator TE can power through an entire day without stopping.



### Tough enough for anything

The Gator TE's quiet exterior hides solid, one-piece forged axles and a cast aluminium rear axle housing, making it tough enough to deal with extreme conditions.



**Full throttle – even on public roads**

The Gator TE can be operated fully road legal which is unique in its category. (optional)



✓	Super-quiet electric operation
	Zero emissions
	Road homologation (optional)
	Deluxe Cargo Box

⚙️	Velocity 0-25 km/h (0-15 mp/h)
	Load capacity 409 kg

🌿	Urban areas (e.g. pedestrian precincts)
	Golf courses
	Industrial premises
	Indoor areas
	Use around horses/livestock, zoos



# Gator TH 6x4

## The problem-solver



✓	Enormous load capacity
	Low load height
	Minimal ground impact
	Deluxe cargo box
	Fuel efficient diesel engine

⚙️	Engine 21 hp
	Velocity 0-32 km/h (0-25 mp/h)
	Load capacity 726 kg

🌿	Construction sites
	Parks
	Cemeteries
	Golf courses
	Agriculture and forestry



### The right tools for the job

Designed to suit you. Transform the cargo box into a flat bed or increase the load capacity from 460 to 920 litres – all in just the blink of an eye.



How can you make light work of a half-ton load? Easy – with the Gator TH 6x4 Diesel. It's our answer to particularly weighty problems and can transport a full 544 kg with no problem at all. What's more, the extremely low load height really takes the weight off your shoulders!

With six wheels and a low centre of gravity, the Gator TH 6x4 keeps your feet firmly on the ground at all times. And because work can never go quickly enough, it's always got enough energy to leap into action – in short, when it comes to action they bring it.



### Tough, but gentle

Even real tough guys have a softer side. And the Gator TH 6x4 is no exception. Although it packs a whole lot of power, it's definitely got the gentle touch when it comes to caring for your turf.

### Full power ahead

The powerful yet economical diesel engine makes the Gator TH 6x4 a speedy mover even when the going gets tough.

## Gator HPX 4x4

Four is the winning number

Love a challenge? So does the Gator HPX 4x4. Try it on tough terrain under tricky conditions and see for yourself! Where other vehicles struggle or even grind to a halt, the Gator's "true" 4-wheel drive ensures maximum torque.

Its hydro formed frame provides the stability you need, and 4-wheel suspension delivers the best in comfort and perfect traction. The robust, overall design is rounded off with a powerful diesel engine that can reach a top speed of 40 km/h. All in all, this is one Gator utility vehicle that needs to be kept on a tight rein!

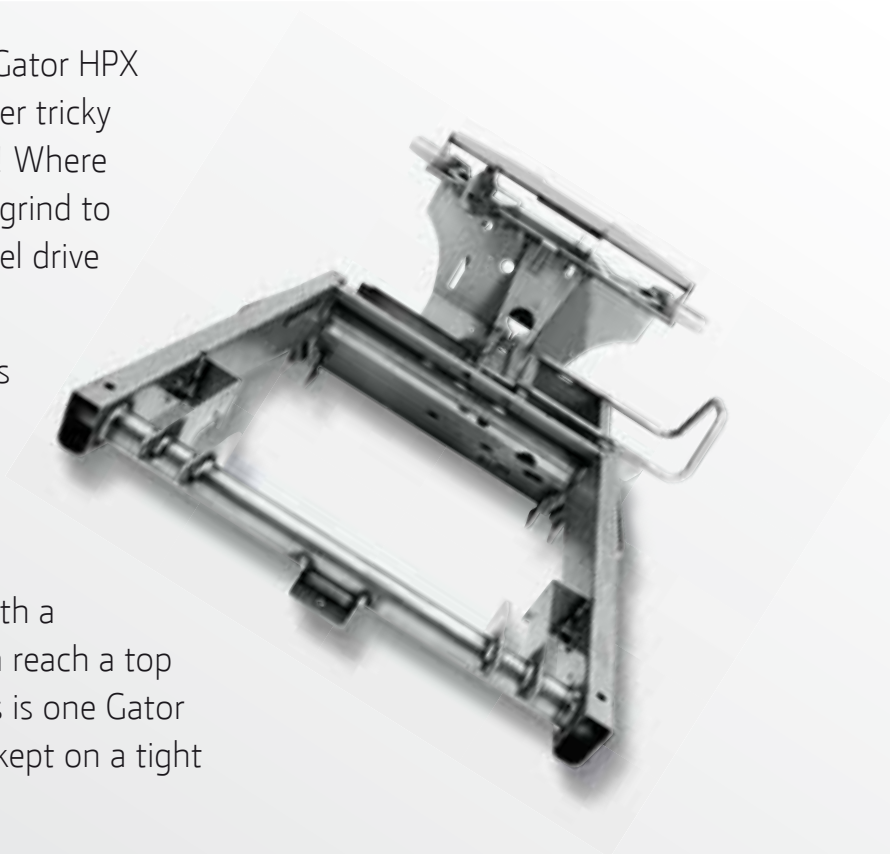

### High strength hydro formed frame

Exclusive hydro formed frame has fewer welded or bolted joints for maximum durability and high tolerances for twisting and heavy loads.

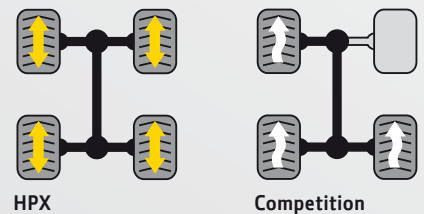

### Stop on a sixpence

Fully hydraulic disc brakes ensure first-class braking performance.

### The strong, silent type

It's powerful and durable – but even with its 854 cc displacement, the diesel engine is now quieter than ever. That type of performance will certainly take some beating.

### True On-Demand 4-Wheel Drive

System activated by a fingertip automatically senses if one of the rear wheels slip and engages both front wheels with full torque to maximize traction. Models manufactured by competitors with limited slip differentials are "3-wheel drive".



**Safety first**

Your safety is a top priority at all times. That's why the Gator HPX 4x4 is fitted with an ROPS canopy and comfortable automobile style 3 point seat belts as standard.



✓	High strength hydro formed steel frame
	4-Wheel Drive
	4-Wheel Suspension
	Comfortable load height
	Standard deluxe ROPS canopy

⚙️	Engine 21 hp
	Velocity 40 km/h (25 mp/h)
	Load capacity 635 kg

🌿	Local authorities
	Agriculture and forestry
	Golf courses
	Leisure parks
	Construction sites



# New: Gator XUV 855 Diesel

Technically it's a working vehicle. Technically...

Introducing the ultimate member of the Gator family – the Gator XUV 855 diesel. When our engineers are given free rein, the result is a utility vehicle that is simply beyond compare.

This Gator utility vehicle is always the right choice – whatever your plans and no matter how tough the terrain. With its innovative technology and ultra-strong components, you won't believe the sheer power of the Gator XUV 855 diesel.

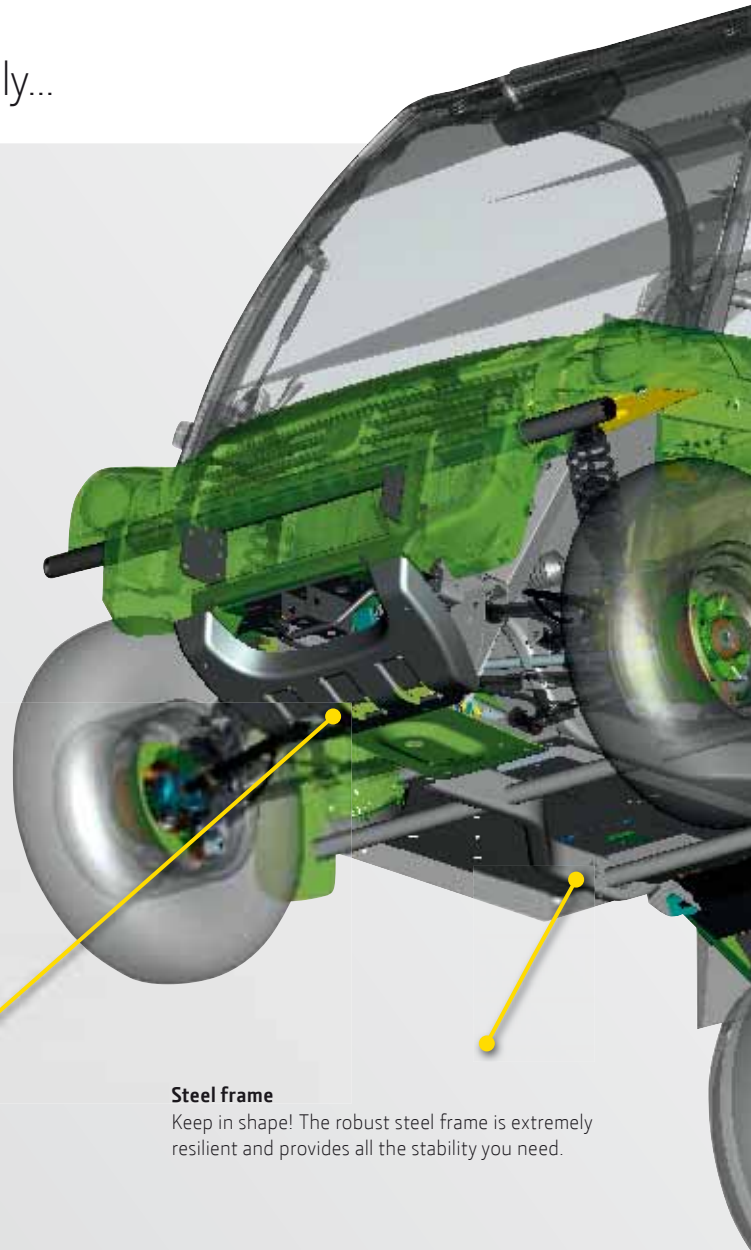

**Steel frame**  
Keep in shape! The robust steel frame is extremely resilient and provides all the stability you need.

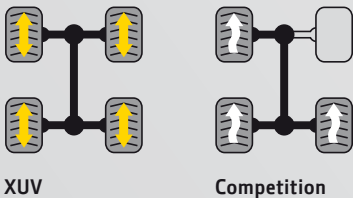

**True, On-Demand 4-Wheel Drive**  
Switch between a perfectly turf friendly traction mode to a locked rear differential to On-Demand True 4WD for maximum traction for the most challenging terrain (a sophisticated electronic interlock engages to prevent all power from being transferred to a wheel that has lost all traction).



**52 km/h max speed\***  
The high-torque, liquid cooled 3-cylinder diesel engine has endless reserves of energy to make the XUV 855 the most powerful diesel in its class.

\*If equipped with EEC road homologation kit max speed is limited to 40 km/h (25 mp/h).





**Deluxe Cargo Box**

The practical, adjustable Deluxe Cargo Box – with 460 litres and 454 kg capacity the biggest in class – means you’re ready to deal with any load!

**Automotive-style brake system**

Massive twin piston 8.25” hydraulic disc brakes bring you to a stop. Ultimately, the system delivers incredible responsiveness at all times.



**Fully enclosed CVT transmission**

Want more speed and comfort combined with even lower consumption? Two-range CVT transmission requires no shifting and delivers far superior efficiency from low-speed pulling to fast top speed.



**Independent double-wishbone suspension**

Impressive front and rear suspension travel sets a new comfort standard and the new sway bar on the rear axle reduces body roll – even in extreme conditions. Suspension can be easily adjusted for varying payloads.

## New: Gator XUV 855 Diesel

### A fun-tastic performer



Three letters that bring an extra helping of fun and productivity to your work: XUV. With a whole lot of power and an attitude to match, this Gator utility vehicle practically gets the work done all by itself.

When conquering hilly terrain, coping with steep fields or fording streams, the XUV really comes into its own. The Gator utility vehicle is completely in its element – and you're in complete control. Hop on – and enjoy the ride!



#### And the winner is ...

With a top speed of 52 km/h\*, the Gator XUV 855 diesel definitely leads the field in its class.

#### Completely under control

4-wheel drive on demand? Turf-friendly mode at all times? The decision is entirely up to you.

#### Sit back and relax!

Even in the very toughest conditions, the Gator XUV ensures a smooth ride and exceptional comfort.



**Choose your colour**

The Gator is also setting new standards in design. Whether in classic green and yellow or refined black and olive, make your choice!



	4-Wheel Drive
	52 km/h max. Speed*
	Independent Rear Suspension (IRS)
	Enclosed CVT transmission
	Deluxe Cargo Box
	Standard deluxe ROPS canopy

	Engine 21 hp
	Velocity 0-52 km/h (0-32 mp/h)
	Load capacity 635 kg
	Available colours Green & Yellow
	Olive & Black

	Agriculture and forestry
	Hunting
	Golf courses
	Leisure

\*If equipped with EEC road homologation kit max speed is limited to 40 km/h (25 mp/h).



## ProGator Utility Vehicle

### Meet our club professional

Only the very best lift the title – and not just in tournaments. That’s why real professionals are needed to keep golf courses and sports fields in trim.

The ProGator utility vehicle helps you master any task that may crop up on the “sacred” turf of sports facilities and golf courses. While the power steering and tight turning radius make driving a real pleasure, the robust cargo box lets you tackle loads in the real heavyweight class. And, because flexibility is always a real advantage, the ProGator utility vehicle qualifies for a whole range of different disciplines. Test it out for yourself!



#### Let the water flow!

That’s no problem with the 750 litre capacity of the HD200 sprayer. And with a range of booms measuring 4.6 m, 5.5 m and 6.4 m, there’s no shortage of choice, either!



#### A master of its craft

The TC25 turf collection system helps you pick up the pace when collecting aeration cores, sand, clippings and leaves.



#### Good top dressing is half the battle

The TD100 Top Dresser features a seamless conveyor belt and a 0.5 m<sup>3</sup> capacity. What’s more, the hopper is made of galvanised steel.



**Not for amateurs ...**

With a payload capacity of 1202 kg, the ProGator utility vehicle can take on even the heaviest tasks.



5 speed synchromesh transmission
Tight turning radius
Low centre of gravity



Displacement 1115 cc
Rated capacity* 1184 kg
Cargo box capacity (calculated) 876 kg



Golf Courses
Sports field

\*including 200 lb. operator, 200 lb. passenger, & loaded attachment

# Options

## Find that special something extra

### Cabs & canopies



#### Deluxe canopy

The Deluxe canopy is standard and is certified to the Society of Automotive Engineers (SAE) requirements to provide roll-over protection. Leaves plenty of head and elbow room. Includes 3 point seat belts and can be enhanced to a full comfort cab. (Standard with HPX and XUV Gators).



Cabs/Canopies	CX	T-Series	HPX / XUV
Deluxe canopy (ROPS)			●
Cab (ROPS)		○	○
Sun canopy	○		
<b>Seating</b>			
High back bucket seats	●	●	●
Bench seat			○
Extra high back sport seat			○
<b>Cab Accessories</b>			
Exterior mirrors		○	●
Windshield (hinged)		○	○
Windshield w wiper		○	○
Windshield washer		○	○
Glass or vinyl doors		○	○
Heater		○	○
Visor		○	○
Interior light		○	○
Beacon light		○	○
Work lights front (2)		○	○
Work light rear (1)		○	○

○ = Optional;  
● = Standard





## Options – Comfort / Convenience



### Gauge package

Electronic speedometer and voltmeter analogue gauges integrated in the instrument panel. Good for precision tasks.



### Windscreen

Easy to attach, height adjustable tinted acrylic windscreen to protect the operator from dust and wind.



### Floor mat

Washable mat protects the floor and minimises dust, debris and noise in the operator station.

## Protection



### Heavy duty brush guard

Strong bumper-mounted heavy duty brush guard provides a modern and aggressive appearance for all Gator HPX and XUV models.



### Brush guard front bumper

Strong, front mounted, new designed bumper with brush guard provides a modern and aggressive appearance for all Gator T-Series models.



### Heavy duty front fender guard

Heavy duty fender guards not only prevent damage from side impact but also provide a modern and aggressive appearance for all Gator HXP and XUV models.



### Rear bumper

The rear bumper offers stylish, heavy duty rear protection to the vehicle.



### Cargo box fender guard

The cargo box fender guard offers enhanced styling in addition to heavy duty protection to the side of the cargo box.



### Cargo box mat

The cargo box bed mat not only protects the steel floor from scratches and dents; it also provides additional cushioning and slip resistance to items being hauled in the cargo box.

## Options – Road Homologation / Lights



### EEC road homologation

Equipped with the EEC road homologation kit your Gator utility vehicle can be used in traffic on public roads.



### Deluxe light kit

The deluxe light kit includes brake lights, taillights, turn signals and four-way flashers. It's not intended to be used on public roads.



### Adventure light kit

Two 55 watt lights mounted on the heavy duty brush guard to provide more illuminated area.

## Enhance / haul / tow

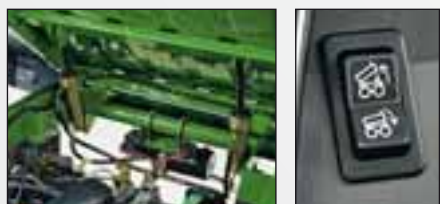

### Cargo box powerlift kit

Easily lower and raise cargo box from the seat with dash mounted switch. Electro-mechanically activated, rated for full box capacity.\*



### Cargo box side wall extension

The four-sided structure easily increases cargo box side height to 533 mm and volume to 0.74 m<sup>3</sup>.



### Cargo box divider

The Deluxe cargo box can be equipped with an optional divider. The dividers can be positioned at the front or rear of the cargo box bed and released quickly without any tools.



### Front rack

Expand the work capabilities of a HPX and XUV Gator with the addition of the front hood rack. The rack easily mounts to the required front brush guard.



### Drawbar hitch

Can be mounted in the standard rear receiver hitch or the optional front receiver hitch for towing trailers.

### Tool rack

The side tool rack enables you to maximise the use of the cargo box by carrying long-handled tools, such as trimmers, shovels and rakes, on the outside of the box. The holders are adjustable, allowing you to carry a wide array of items in the racks.



\*Please note: Compact and Traditional Series single cylinder electromechanical. High Performance Series dual cylinder and Ultimate Series single cylinder hydraulic.



## All Accessories at a glance

	CX	TS	TX / TX Turf / TE / TH 6x4	HPX	XUV
<b>Comfort / Convenience</b>					
Adjustable operator's seat	●	○	○	●	●
Glove box	●	●	●	●	●
12 V DC power outlet	●	●	●	●	●
Cup holder	●	●	●	●	●
Gauge kit (speedo- and voltmeter)		○	○		
Windscreen	○	○	○		
Exterior mirrors	○	○	○	●	●
Floor mat	○	○	○	○	○
<b>Road Homologation / Lights</b>					
EEC road homologation		○	○	○	○
Deluxe Light Kit	○	○	○	○	○
Brake/Tail Light Kit		○	○	○	○
Adventure Light Kit				○	○
Back-up Alarm	○	○	○	○	○
Horn	○	○	○	○	○
<b>Protection</b>					
Front bumper	○	○	○	●	●
Brush guard		○	○		
HD brush guard				○	○
Fender guard		○	○		
HD fender guard				○	○
CV guards (front and rear)				○	○
Skid plate				○	
HD skid plate					○
Rear bumper			○		○
Cargo box fender guard			○		○
Brake and taillight protector			○		○
Cargo box bedliner	○			○	
Cargo box spray in bedliner		●	●		●
Cargo box mat	○	○	○	○	○
HD front suspension	○	○	○	○	●
Splash guards		○	○		
Vehicle cover	○	○	○	○	○
<b>Enhance / haul / tow</b>					
Deluxe cargo box			●		●
Manual lift assist	●		●		●
Cargo box power lift	○	○	○	○	○
Cargo box side wall extension		○	○	○	○
Cargo box divider kit			○		○
Cargo box tool rack			○		○
Front rack				○	○
Rear hitch	○	○	○	○	○
Rear receiver hitch	○	○	○	○	●
Drawbar hitch	○	○	○	○	○
Front receiver hitch	○	○	○	○	●
Tyre chains	○	○	○	○	○

○ = Optional

● = Standard

# Much more than “just” a Utility Vehicle

## Handy attachments for your Gator utility vehicle



### 54 Front Blade (1.37 m)

- Snow removal/light duty grading
- 3 position manual angling
- Quick attach system
- Two adjustable skid shoes
- Replaceable cutting edge



### 72 Front Blade (1.83 m)

- Snow removal/light material blading
- 3 position manual angling
- Electro-hydraulic lift system
- Quick attach system
- Two adjustable skid shoes
- Replaceable cutting edge



### 72 V- Front Blade (1.83 m)

- Snow removal/light material blading
- 3 position manual angling
- Electro-hydraulic lift system
- Quick attach system
- Two adjustable skid shoes
- Replaceable cutting edge



### Winch

- For loads up to 1134 kg
- Designed for moving logs, pulling out bushes with control or tension fences
- Increased efficiency and improved load distribution due to quiet, three-stage planetary gear design
- Mounts front and rear

Compatibility	CX	T-Series	HPX / XUV
54 Blade (1.37 m)	●		
72 Blade (1.83 m)		●	●
72 V-Blade (1.83 m)		●	●
Winch		●	●

● = Available



# Always ready to go

## Making sure your Gator utility vehicle meets your needs



**Turf**

- Gentle to the Turf
- Very good traction on damp surfaces
- High level of comfort
- Smooth running
- Low wear on hard surfaces

**AT (All Terrain)**

- Universal all-round tyres for on and off-road use
- Good traction off-road
- Low ground pressure



**KT (Knobby)**

- Universal all-round tyres preferably for off-road use
- Good traction off-road
- Low ground pressure



**XT (Extreme Terrain)**

- Outstanding traction off-road
- Puncture resistant
- Can also be used on-road



**HPAP (All Purpose)**

- Universal all-round tyres for on and off-road use
- Good traction off-road
- Low ground pressure



**HPAT (Aggressive Tread)**

- Aggressive off-road tyre
- Heavy-duty tread
- Maximum wheel grip off-road



**XT (Ancla Extreme Terrain)**

- Aggressive off-road tread pattern
- Superior traction in mud, without sacrificing ride comfort
- 4-ply rating for excellent puncture resistance



**XT**

- (Maxxis Xtreme Terrain on 14" alloy rims)
- Radial tyre construction provides better shock absorption
  - Yellow alloy rims for maximum performance and look
  - Non-directional tread pattern provides predictable cornering and claws up roots and rocks
  - 6-ply rating for maximum puncture resistance and lifetime

Compatibility	CX	TS	TX	TH 6x4	TX Turf / TE	HPX	XUV
Turf	●	○	●	○	●	○	
AT (All Terrain)		○	○	○			●
KT (Knobby)		●		●			
XT (Extrem Terrain)			○				
HPAP (All Purpose)						●	
HPAT (Aggressive Tread)						○	
XT (Ancla Extrem Terrain)							○
XT (Maxxis Xtreme Terrain on 14" alloy rims)							○

○ = Optional;  
● = Standard

# Specifications

## CX, TE, TS

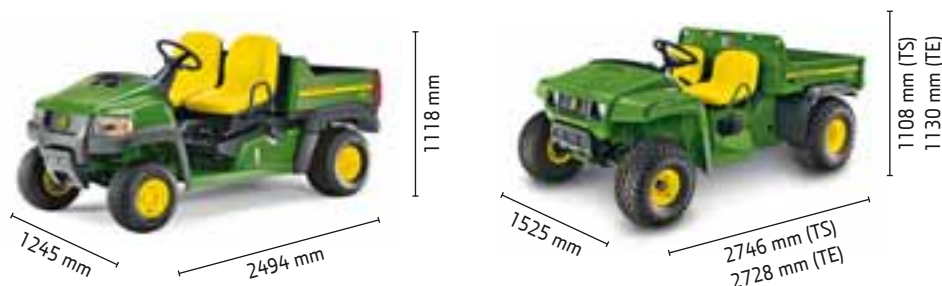

Model	Gator CX	Gator TS	Gator TE
<b>Engine</b>			
Type	286 cc, 1-cylinder, 4-cycle OHV petrol	350 cc, 1-cylinder, 4-cycle OHV petrol	Separately excited 48V D.C. motor
Power (ECE-R24), kW / hp @ min <sup>-1</sup>	5.7 / 7.8 @ 3300	7.1 / 9.7 @ 3300	–
Power (SAE gross), kW / hp	7.1 / 9.7	8.3 / 11.3	–
Maximum Torque, Nm @ rpm	19.5 @ 2500	18.6 @ 2500	–
Cooling System	Air	Air	Air
Fuel Tank, litre	11.4	19	–
Fuel Consumption*, litre/hour	1.5	1.7	–
<b>Drive System</b>			
Type	1-speed CVT (Continuously Variable Transmission)	1-speed CVT (Continuously Variable Transmission)	Dana with helical gearing
Ground Speed, km/h	0 – 24	0 – 32	0 – 25
Differential lock	Standard, hand-operated	Standard, hand-operated	–
Brakes	Wet disc in transaxle	Wet disc in transaxle	Self-adjusting rear drum
Suspension, Front	Independent Spring-over-shock Single A-arm with adjustment	Independent Spring-over-shock Single A-arm with adjustment	Independent Spring-over-shock Single A-arm with adjustment
Suspension, Rear	Triple-rate spring-over-shock	two high-flotation, low pressure tyres (solid axles)	two high-flotation, low pressure tyres (solid axles)
Suspension Travel Front / Rear, mm	82 / 89	127 / –	127 / –
<b>Dimensions</b>			
Weight (Including Fuel/Fluids), kg	312	415	627 (with batteries)
Towing Capacity (On Level Terrain), kg	272	408	273
Payload Capacity, kg	363	408	409
<b>Ground Clearance</b>			
Under Transaxle, mm	122	152.4	185
Under Foot Platform, mm	178	250	216
<b>Cargo Box</b>			
Type / Material	High-density cross-linked polyethylene	Standard (16 gauge steel)	Deluxe (Polypropylene side panels and tailgate; steel floor and load guard)
Dimensions, mm	735 x 970 x 198	1004 x 1244 x 229	1143 x 1320 x 305
Volume, m <sup>3</sup>	0.15	0.29	0.46
Capacity, kg	182	227	227
<b>Tyres</b>			
Front	20x8.5-8 4PR	22.5x10.00-8 4PR	22.5x9.50-10 4PR
Rear	20x10.00-8 4PR	25x12.00-9 4PR (KT, Turf) 25x13.00-9 4PR (AT)	24x12.00-10 4PR
Other features	Dual cupholders Glove box Hourmeter Fuel sight gauge 12 volt DC outlet	Dual cupholders Glove box Hourmeter Fuel sight gauge 12 volt DC outlet	Dual cupholders Glove box Hourmeter

\*half load at average speed



# Specifications

## TX, TX Turf, TH 6x4

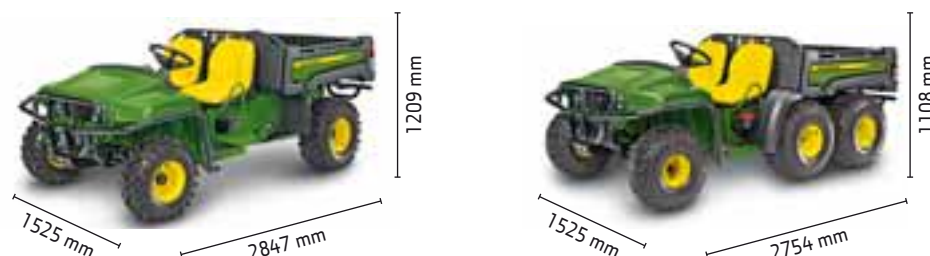

Model	Gator TX	Gator TX Turf	Gator TH 6x4 Diesel
<b>Engine</b>			
Type	675 cc, V-Twin, 4-cycle OHV petrol	401 cc, 1-cylinder, 4-cycle OHV petrol with pedal start	854 cc, 3-cylinder, 4-cycle OHV diesel
Power (ECE-R24), kW / hp @ min <sup>-1</sup>	12.5 / 16.8 @ 3200	8.0 / 10.9 @ 3250	13.6 / 18.5 @ 3400
Power (SAE gross), kW / hp	14.2 / 19	9.7 / 13.2	15.5 / 21
Maximum Torque, Nm @ rpm	50.2 @ 2400	26.4 @ 2400	50 @ 2400
Cooling System	Air	Air	Liquid / 2 radiators
Fuel Tank, litre	19	19	19
Fuel Consumption*, litre/hour	1.3	1.3	0.95
<b>Drive System</b>			
Type	1-speed CVT (Continuously Variable Transmission)	1-speed CVT (Continuously Variable Transmission)	1-speed CVT (Continuously Variable Transmission)
Ground Speed, km/h	0 – 32	0 – 25	0 – 32
Differential lock	Standard, hand-operated	N/A	Standard, hand-operated
Brakes	Front / rear hydraulic disc	Front / rear hydraulic disc	Wet disc in transaxle
Suspension, Front	Independent Spring-over-shock Single A-arm with adjustment	Independent Spring-over-shock Single A-arm with adjustment	Independent Spring-over-shock Single A-arm with adjustment
Suspension, Rear	Semi-independent coil over shock (COS) system	Semi-independent coil over shock (COS) system	Four high-floatation, low pressure tyres (solid axles)
Suspension Travel Front / Rear, mm	127 / 76	127 / 76	127 / N/A
<b>Dimensions</b>			
Weight (Including Fuel/Fluids), kg	508	501	630
Towing Capacity (On Level Terrain), kg	454	454	726
Payload Capacity, kg	454	454	726
<b>Ground Clearance</b>			
Under Transaxle, mm	145	145	165
Under Foot Platform, mm	270	270	216
<b>Cargo Box</b>			
Type / Material	Deluxe (Polypropylene side panels and tailgate; steel floor and load guard)	Deluxe (Polypropylene side panels and tailgate; steel floor and load guard)	Deluxe (Polypropylene side panels and tailgate; steel floor and load guard)
Dimensions, mm	1143 x 1320 x 305	1143 x 1320 x 305	1143 x 1320 x 305
Volume, m <sup>3</sup>	0.46	0.46	0.46
Capacity, kg	272	272	544
<b>Tyres</b>			
Front	22x9.50-10 4PR	22x9.50-10 4PR	22.5x10.00-8 4PR
Rear	24x10.50-10 4PR (AT) 24x12.00-10 4PR (Turf, XT)	24x12.00-10 4PR	25x12.00-9 4PR (Turf, KT) 25x13.00-9 4PR (AT)
Other features	Dual cupholders Glove box Hourmeter Fuel gauge 12 volt DC outlet additional Pedal Start on TX Turf	Dual cupholders Glove box Hourmeter Fuel gauge 12 volt DC outlet additional Pedal Start on TX Turf	Dual cupholders Glove box Hourmeter Fuel gauge 12 volt DC outlet

\*half load at average speed

# Specifications

## HPX, XUV, ProGator

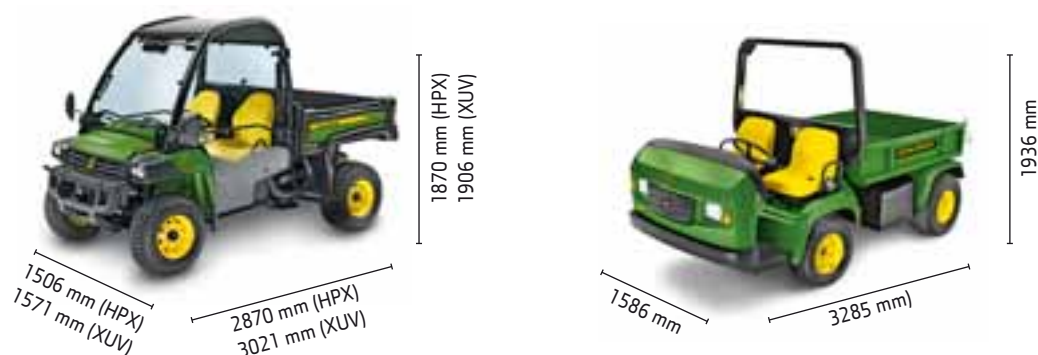

Model	Gator HPX 4x4 Diesel	Gator XUV 855 Diesel 4x4**	Pro Gator 2030A
<b>Engine</b>			
Type	854 cc, 3-cylinder, 4-cycle OHV Diesel	854 cc, 3-cylinder, 4-cycle OHV Diesel	1115 cc, 3-cylinder, 4-cycle OHV Diesel
Power (ECE-R24), kW / hp @ min <sup>-1</sup>	13.6 / 18.5 @ 3400	16.1 / 21.9 @ 3400	17.7 / 24 @ 3600
Power (SAE gross), kW / hp	15.5 / 21	18.3 / 24.9	–
Maximum Torque, Nm @ rpm	45 @ 2500	50 @ 2400	62 @ 2400
Cooling System	Liquid	Liquid	Liquid
Fuel Tank, litre	20	20	30
Fuel Consumption*, litre/hour	0.95	1.89	–
<b>Drive System</b>			
Type	2-speed CVT (Continuously Variable Transmission)	2-speed CVT (Continuously Variable Transmission)	5-speed synchro-mesh
Ground Speed, km/h	0 – 40	0 – 52 (0-40 with EEC homologation)	4.5 – 30.7
Differential lock	Standard, hand-operated	Standard, hand-operated	Standard, hand-operated
Brakes	Front/rear hydraulic disc	Front/rear hydraulic disc	4 wheel hydraulic drum
Suspension, Front	MacPherson strut Single A-arm with adjustable spring preload	Fully Independent dual control arm with adjustable spring preload	Dual leaf springs and shocks
Suspension, Rear	Coil over shock w preload	Fully Independent Dual A-Arm with adjustable coils and sway bar	Dual leaf springs and shocks
Suspension Travel Front / Rear, mm	131 / 75	203 / 229	55 / 55
<b>Dimensions</b>			
Weight (Including Fuel/Fluids), kg	757	877	984 (with Cargo Box)
Towing Capacity (On Level Terrain), kg	590	680	680
Payload Capacity, kg	635	635	1202
<b>Ground Clearance</b>			
Under Transaxle, mm	152	267	168
Under Foot Platform, mm	305	311	–
<b>Cargo Box</b>			
Type / Material	Standard (16 gauge steel)	Deluxe (Polypropylene side panels and tailgate; steel floor and load guard)	Steel
Dimensions, mm	1116 x 1244 x 229	1143 x 1320 x 305	1650 x 1270 x 270
Volume, m <sup>3</sup>	0.32	0.46	0.57
Capacity, kg	454	454	876
<b>Tyres</b>			
Front	24x9.50-10 4PR	26x9.00-12 4PR (XT) 25x9.00-12 4PR (AT)	23x10.50-12 4PR
Rear	24x12.00-10 4PR (Turf HPAP) 24x10.50-10 4PR (HPAT)	26x11.00-12 4PR (XT) 25x11.00-12 4PR (AT)	26x12.00-12 4PR
Other features	Dual cupholders Glove box Hourmeter Fuel gauge 12 volt DC outlet	Dual cupholders Glove box Hourmeter Fuel gauge 12 volt DC outlet	–

\*half load at average speed

\*\*2 colour options available: Green & Yellow / Olive & Black



## John Deere Parts



Is your season getting shorter? Do you need an excellent performing machine? Do you need a reliable machine and reliable service in case anything happens? That's just what you can expect when you do business with John Deere and rely on genuine John Deere parts.

## John Deere Collection



John Deere collection: John Deere gifts and merchandise offer something special for everyone. At [www.JohnDeereShop.com](http://www.JohnDeereShop.com) you can download our catalogue and shop online. Or visit your local John Deere dealer – if the item you want is not in stock, the staff will be happy to order it for you.

# You'll never walk alone

Want quick, straightforward advice from an expert? Then look no further than your local John Deere dealer. He's always there for you – whether you need an original service part, a specialist diagnosis or “just” a bit of help from those in the know. As a designated quality expert, your dealer is always ready to support you. Because we know that incomparable products deserve incomparable service.



**JOHN DEERE**

[JohnDeere.com](http://JohnDeere.com)