

# Spartan

GC-1202E  
EN

**RTM Injection System**  
**For use with Polyester Resin and Gel-Coat**

**Part 21650-00**

Maximum fluid working pressure:  
1300 psi. (9 MPa, 90 bar)

Maximum air pressure:  
100 psi. (0.7 MPa, 7 bar)



**Important Safety Instructions**  
Read all warnings and instructions in  
this manual. Save these instructions.

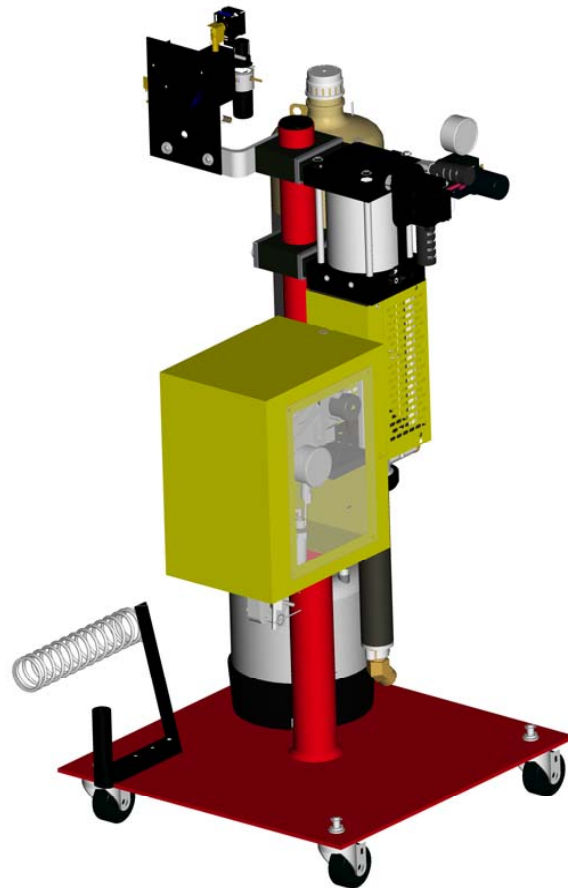

# Contents

## Warnings

Warnings .....	3
Important Safety Information .....	5
Grounding .....	6

## Set-up

Set-up Instructions .....	7
Pressure Relief Instructions .....	9
Start-up Instructions .....	10
Shut-down Instructions .....	16
Parts .....	17
Assembly Drawings .....	18
Sub-Assembly Drawings .....	24

## Maintenance

Maintenance .....	30
-------------------	----

## Technical Data





Technical Data .....	31
Graco Ohio Standard Warranty .....	32
Graco Ohio Information .....	32

N/A = Non Applicable





# Warnings

The following warnings are for the setup, use, grounding, maintenance, and repair of this equipment. The exclamation point symbol alerts you to a general warning and the hazard symbol refers to procedure-specific risk. Refer back to these warnings. Additional, product-specific warnings may be found throughout the body of this manual where applicable.

- See Important Safety Information - MEKP, Polyester Resins and Gel-Coats and Spraying and Lamination Operations section of this manual.

 <b>WARNING</b>	
	<p><b>FIRE AND EXPLOSION HAZARD</b></p> <p>Flammable fumes, such as solvent and paint fumes, in <b>work area</b> can ignite or explode. To help prevent fire and explosion:</p> <ul style="list-style-type: none"> <li>• Use equipment only in well ventilated area.</li> <li>• Eliminate all ignition sources; such as pilot lights, cigarettes, portable electric lamps, and plastic drop cloths (potential static arc).</li> <li>• Keep work area free of debris, including solvent, rags and gasoline.</li> <li>• Do not plug or unplug power cords, or turn power or light switches on or off when flammable fumes are present.</li> <li>• Ground all equipment in the work area. See <b>Grounding</b> instructions.</li> <li>• Use only grounded hoses.</li> <li>• Hold gun firmly to side of grounded pail when triggering into pail.</li> <li>• If there is static sparking or you feel a shock, <b>stop operation immediately</b>. Do not use equipment until you identify and correct the problem.</li> <li>• Keep a working fire extinguisher in the work area.</li> </ul>
	<p><b>PERSONAL PROTECTIVE EQUIPMENT</b></p> <p>You must wear appropriate protective equipment when operating, servicing, or when in the operating area of the equipment to help protect you from serious injury, including eye injury, inhalation of toxic fumes, burns, and hearing loss. This equipment includes but is not limited to:</p> <ul style="list-style-type: none"> <li>• Protective eyewear</li> <li>• Clothing and respirator as recommended by the fluid and solvent manufacturer</li> <li>• Gloves</li> <li>• Hearing protection</li> </ul>
	<p><b>TOXIC FLUID OR FUMES HAZARD</b></p> <p>Toxic fluids or fumes can cause serious injury or death if splashed in the eyes or on skin, inhaled, or swallowed.</p> <ul style="list-style-type: none"> <li>• Read MSDS's to know the specific hazards of the fluids you are using.</li> <li>• Store hazardous fluid in approved containers, and dispose of it according to applicable guidelines.</li> <li>• Always wear impervious gloves when spraying or cleaning equipment.</li> </ul>

## Warnings

 <b>WARNING</b>	
	<p><b>SKIN INJECTION HAZARD</b> High-pressure fluid from gun, hose leaks, or ruptured components will pierce skin. This may look like just a cut, but it is a serious injury that can result in amputation. <b>Get immediate surgical treatment.</b></p> <ul style="list-style-type: none"> <li>• Do not point gun at anyone or at any part of the body.</li> <li>• Do not put your hand over the dispense outlet.</li> <li>• Do not stop or deflect leaks with your hand, body, glove, or rag.</li> <li>• Engage trigger lock when not spraying.</li> <li>• Follow <b>Pressure Relief Procedure</b> in this manual, when you stop spraying and before cleaning, checking, or servicing equipment.</li> </ul>
	<p><b>MOVING PARTS HAZARD</b> Moving parts can pinch or amputate fingers and other body parts.</p> <ul style="list-style-type: none"> <li>• Keep clear of moving parts.</li> <li>• Do not operate equipment with protective guards or covers removed.</li> <li>• Pressurized equipment can start without warning. Before checking, moving, or servicing equipment, follow the <b>Pressure Relief Procedure</b> in this manual. Disconnect power or air supply.</li> </ul>
	<p><b>EQUIPMENT MISUSE HAZARD</b> Misuse can cause death or serious injury.</p> <ul style="list-style-type: none"> <li>• Do not operate the unit when fatigued or under the influence of drugs or alcohol.</li> <li>• Do not exceed the maximum working pressure or temperature rating of the lowest rated system component. See <b>Technical Data</b> in all equipment manuals.</li> <li>• Use fluids and solvents that are compatible with equipment wetted parts. See <b>Technical Data</b> in all equipment manuals. Read fluid and solvent manufacturer's warnings. For complete information about your material, request MSDS forms from distributor or retailer.</li> <li>• Check equipment daily. Repair or replace worn or damaged parts immediately with genuine manufacturer's replacement parts only.</li> <li>• Do not alter or modify equipment.</li> <li>• Use equipment only for its intended purpose. Call your distributor for information.</li> <li>• Route hoses and cables away from traffic areas, sharp edges, moving parts, and hot surfaces.</li> <li>• Do not kink or over bend hoses or use hoses to pull equipment.</li> <li>• Keep children and animals away from work area.</li> <li>• Comply with all applicable safety regulations.</li> </ul>
	<p><b>PRESSURIZED ALUMINUM PARTS HAZARD</b> Do not use 1,1,1-trichloroethane, methylene chloride, other halogenated hydrocarbon solvents or fluids containing such solvents in pressurized aluminum equipment. Such use can cause serious chemical reaction and equipment rupture, and result in death, serious injury, and property damage.</p>

## Important Safety Information

### Methyl Ethyl Ketone Peroxide (MEKP)

MEKP is among the more hazardous materials found in commercial channels. Proper handling of the “unstable (reactive)” chemicals presents a definite challenge to the plastics industry. The highly reactive property which makes MEKP valuable to the plastics industry in producing the curing reaction of polyester resins and gel-coats also produces the hazards which require great care and caution in its storage, transportation, handling, processing and disposal.

Workers must be thoroughly informed of the hazards that may result from improper handling of MEKP, especially in regards to contamination and heat. They must be thoroughly instructed regarding the proper action to be taken in the storage, use and disposal of MEKP and other hazardous materials used in the laminating operation.



**MEKP is flammable and potentially explosive, as well as potentially damaging to the eyes and skin.**

**Read material manufacturer’s warnings and material MSDS to know specific hazards and precautions related to MEKP.**

Contaminated MEKP can become explosive. Prevent contamination of MEKP with other materials, which includes, but is not limited to polyester overspray, polymerization accelerators and promoters, and non-stainless metals. Even small amounts of contaminants can make MEKP explosive. This reaction may start slowly, and gradually build-up heat, which can accelerate until fire or an explosion result. This process can take from seconds to days.

Heat applied to MEKP, or heat build-up from contamination reactions can cause it to reach what is called its Self-Accelerating Decomposition Temperature (SADT), which can cause fire or explosion.

Spills should be promptly removed, so no residues remain. Spillage can heat up to the point of self-ignition. Dispose in accordance with manufacture’s recommendation.

Store MEKP in a cool, dry and well-ventilated area in the original containers away from direct sunlight and away from other chemicals. It is strongly recommended that the storage temperature remain below 86° F (30° C). Heat will increase the potential for explosive decomposition. Refer to NFPA 432. Keep MEKP away from heat, sparks and open flames.

Current catalysts are premixed and do not require any diluents. GlasCraft strongly recommends that diluents not be used. Diluents add to the possibility of contaminants entering the catalyst system. Never dilute MEKP with acetone or any solvent since this can produce an extremely shock-sensitive compound which can explode.

Use only original equipment or equivalent parts from GlasCraft in the catalyst system (i.e.: hoses, fittings, etc.) because a hazardous chemical reaction may result between substituted parts and MEKP.

To prevent contact with MEKP, appropriate personal protective equipment, including chemically impermeable gloves, boots, aprons and goggles are required for everyone in the work area.

### Polyester Resins and Gel-Coats



Spraying materials containing polyester resin and gel-coats creates potentially harmful mist, vapors and atomized particulates. Prevent inhalation by providing sufficient ventilation and the use of respirators in the work area.

Read the material manufacturer’s warnings and material MSDS to know specific hazards and precautions related to polyester resins and gel-coats.

To prevent contact with polyester resins and gel-coats, appropriate personal protective equipment, including chemically impermeable gloves, boots, aprons and goggles are required for everyone in the work area.

### Spraying and Lamination Operations





Remove all accumulations of overspray, FRP sandings, etc. from the building as they occur. If this waste is allowed to build up, spillage of catalyst is more likely to start a fire.

If cleaning solvents are required, read material manufacture’s warnings and material MSDS to know specific hazards and precautions. (GlasCraft recommends that clean-up solvents be nonflammable.)



**GlasCraft** recommends that you consult OSHA Sections 1910.94, 1910.106, 1910.107 and NFPA No. 33, Chapter 16,17, and NFPA No. 91 for further guidance.

# Grounding

						
<p><i>This equipment needs to be grounded.</i></p>						

Ground the dispense gun through connection to a GlasCraft approved grounded fluid supply hose.

Check your local electrical code and related manuals for detailed grounding instructions of all equipment in the work area.

 *A grounding wire and clamp are provided, assembly p/n 17440-00 with all FRP equipment.*

# Set-Up

The Spartan comes complete and fitted with all resin hoses, catalyst bottle and filters. The injection head is fully connected to the machine circuit and tested and secured against leaks prior to dispatch.

*The following instructions are to be used as a guide for consistent and continual operation. Any deviation from the "standard operation", usually requires more maintenance to the equipment and material formulation to assure consistent results. For example: the use of fillers in resins.*

1. Select a clean, dry air supply.
2. Attach a 3/8" or larger air hose to the Air Inlet on the yellow air lock-out valve.

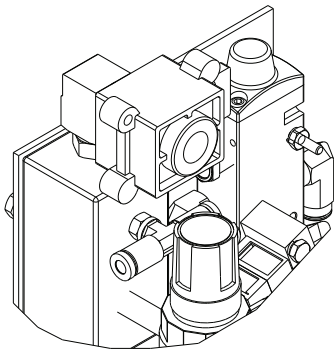

*It is suggested that a quick disconnect fitting not be used for attaching air. Quick disconnect fittings can severely limit air flow.*

<p>Before turning on main air, check all fittings, making certain they are securely tightened. This should be done before air or material of any kind is introduced into the system.</p>						

3. Attach Grounding Clamp Assembly, P/N 17440-00, to system. Use a convenient Nut and Bolt to secure Lug, P/N 13193-00, to slave pump.
4. Securely attach Clamp, P/N 7749-00 to permanently grounded rod or pipe.

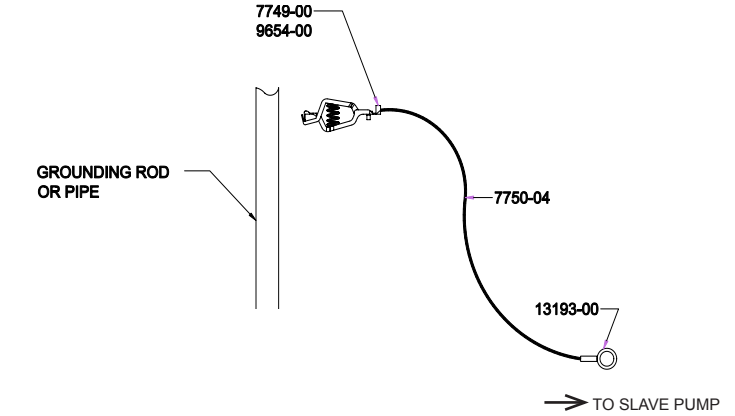

<p>Whenever flammable or combustible liquids are transferred from one container to another, both containers shall be effectively bonded and grounded to dissipate static electricity. For further information see..... NFPA 77, Recommended Practice on Static Electricity.</p>						

5. Remove the pump inlet safety cap and drain the testing oil into an open container.
6. Attach 4 casters with provided lock washer, washer and nut. Attach solvent tank support rod on back left caster.

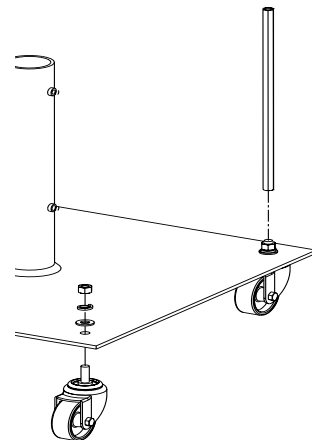

7. Attach solvent tank to solvent tank support rod with provided rubber strap.

## Set-Up

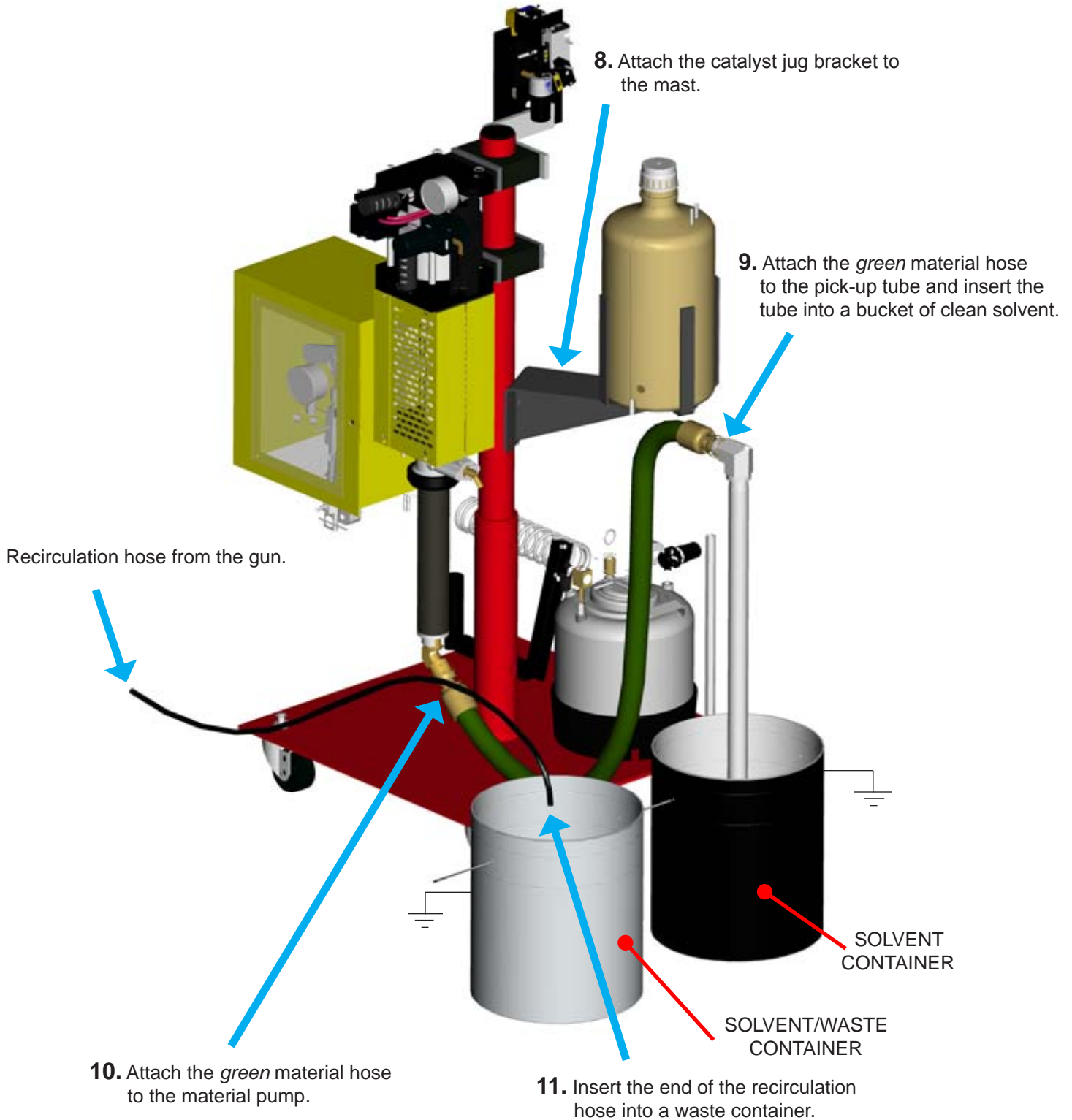



# Pressure Relief Procedure



To relieve fluid and air pressures:

1. Push Yellow slide valve, P/N 21402-00 to bleed off air to system.

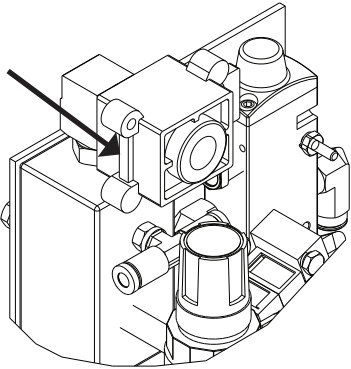

2. Open P/N 21228-00 on catalyst pump to recirculation position.

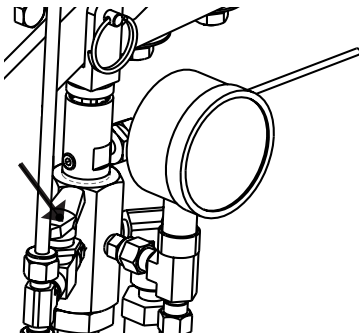

3. Open P/N 21192-00 on bottom of material pump.

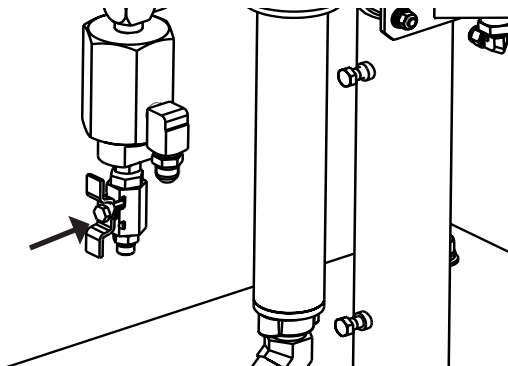

## Start-Up

12. Make sure solvent regulator is dialed to zero.  
(Turn knob fully counter-clockwise)

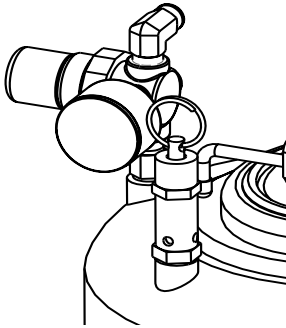

13. Carefully relieve any pressure in the solvent tank by slowly pulling the relief valve.

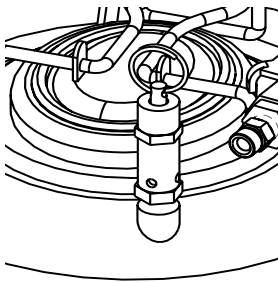

14. After all the pressure is released from the tank, open the lid and fill the tank with a suitable, clean flushing solvent and close the lid securely.

15. Remove yellow guard using a 5/32" hex balldriver.

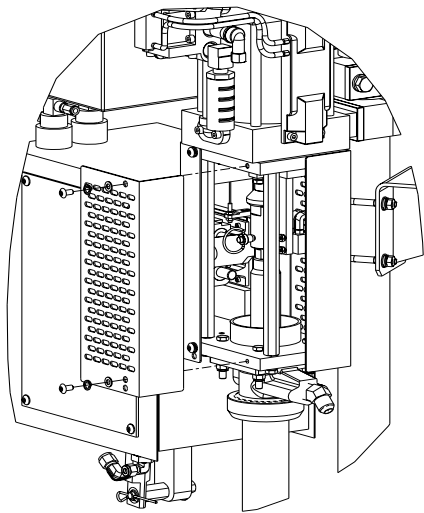

16. Fill material pump lube cup with proper pump lube.

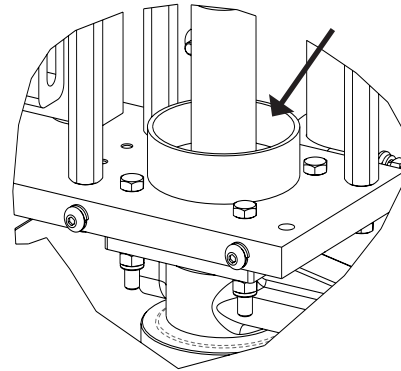

17. Replace yellow guard using a 5/32" hex balldriver.

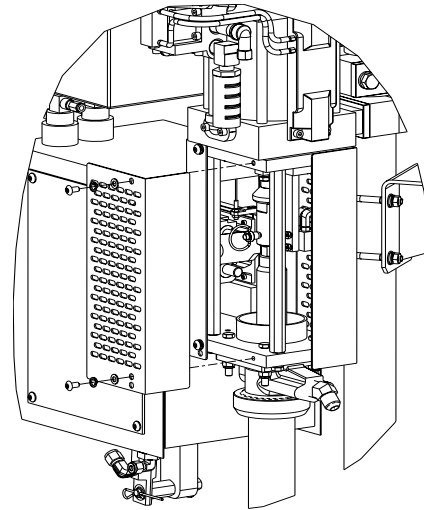

18. Before operating the material pump, flush thoroughly with a clean, suitable solvent to remove test fluid.

19. Safely fill the Catalyst Supply Bottle, P/N LPA-165, (maximum two gallons) with preferred MEKP catalyst, to a minimum level of at least two inches above the Catalyst Bottle Outlet Fitting.



*GlasCraft uses test fluid that may not be compatible with some resins. It is recommended that the test fluid be flushed from the material pump fluid section. Make sure hose fittings on the pick-up hoses are tight.*

<p>Remove Catalyst Bottle, P/N 20941-00 from Catalyst Bottle bracket, P/N LPA-169 for filling. Bottle should be placed at or below lowest level for safe filling. Never fill Catalyst bottle while mounted in bracket as personal injury from catalyst spillage could result.</p>						

## Start-Up

The Spartan II comes complete and fitted with all resin hoses, catalyst bottle and filters. The injection head is fully connected to the machine circuit and tested and secured against leaks prior to dispatch.



The following instructions are to be used as a guide for consistent and continual operation. Any deviation from the "standard operation", usually requires more maintenance to the equipment and material formulation to assure consistent results. For example: the use of fillers in resins.



Refer to specific user manuals (if available) for detailed component start-up and shut-down instructions.

## Solvent



Before initial operation of any internal mix system, make certain the solvent flush set-up is fully operational.

1. Turn solvent regulator clockwise to approximately 65 psi.

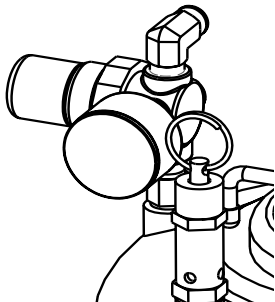

2. Place injection nozzle over a proper waste container. Turn 3-way valve on top of the solvent tank so the arrow is pointing up for air purge, for solvent turn the valve so the arrow is pointing down. Repeat air purge to blow solvent through the gun head.

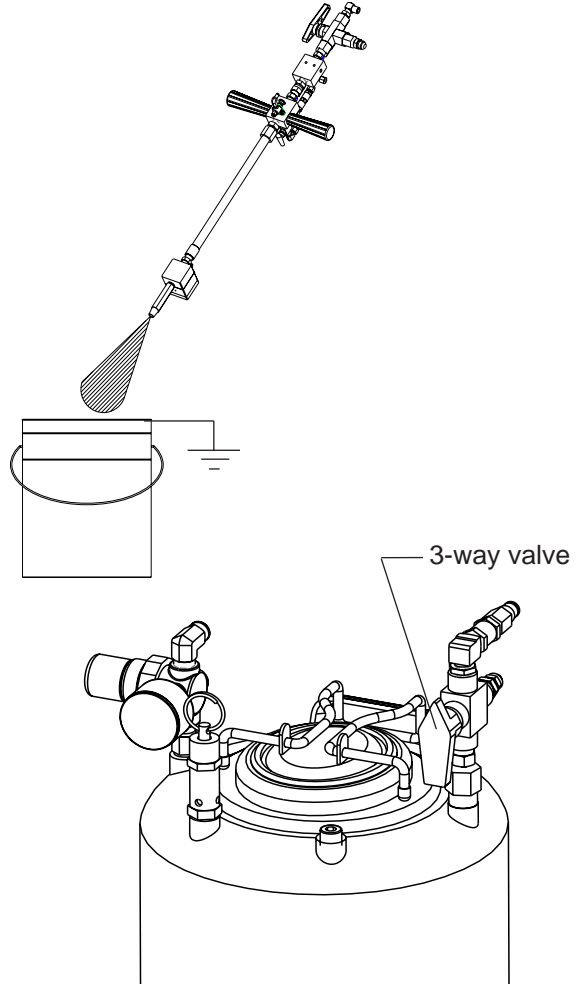

3. Exhaust air through the gun head until traces of solvent have been dissipated.



Since the system is an internal mix system, the mixer requires flushing with air-solvent-air after each dispense or before the mixed material starts to gel.

# Start-Up

## Resin

1. Detach the catalyst slave pump from the material pump. Pull and rotate knob to disengage the catalyst drive arm.

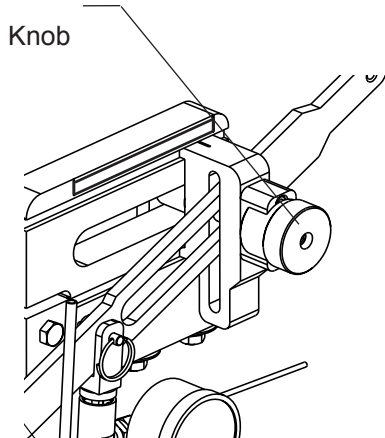

2. Turn main valve on the gun head to the recirculation position.

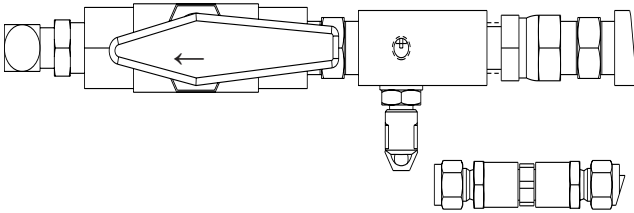

3. Turn the material air regulator fully counter-clockwise.

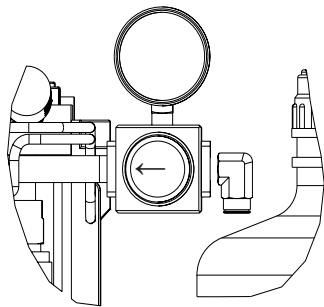

4. Switch machine recirculation to "ON".

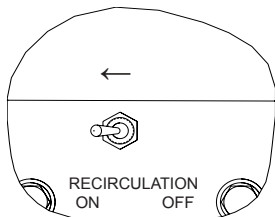

5. Turn the material injection regulator slowly clockwise until gauge indicates 10 PSI or until pump cycles slowly.

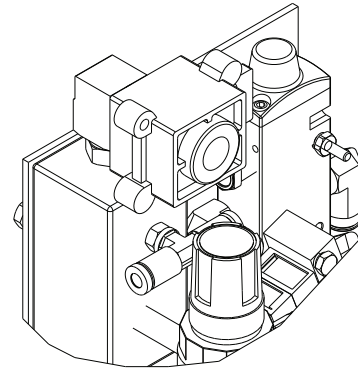

6. Pump should cycle clean solvent through the system and out the recirculation hose.

7. End recirculation when solvent appears reasonably clean. "OFF"

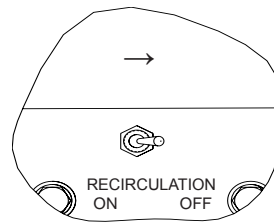

8. Remove material pump pick-up tube from solvent container and dry thoroughly.

9. Switch machine recirculation to "ON".

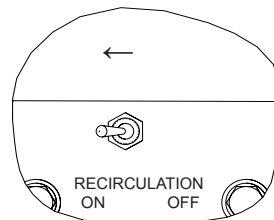

## Start-Up

10. When solvent has stopped exiting the recirculation hose, end recirculation. (OFF)

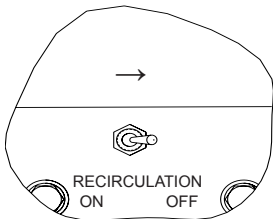

11. Place material pump pick-up tube in desired container of material while keeping recirculation return hose in a waste container.

12. Turn machine to recirculation. (ON)

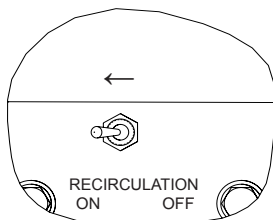

13. Let material pump cycle slowly until a steady stream of clean material is seen exiting the recirculation hose.

14. Switch machine recirculation to "OFF".

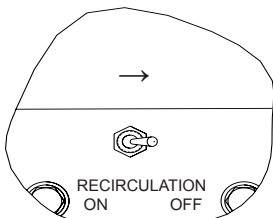

15. Secure recirculation hose in the material supply container.

 *Dispose of resin in the waste container in a proper manner.*

## Catalyst

1. Turn Catalyst Valve on the dispense gun to recirculation position (arrow on valve should point away from gun block).

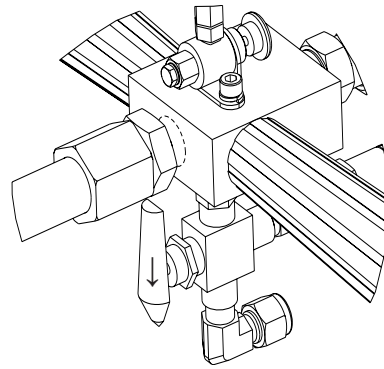

*Make sure all the air is purged out of the catalyst pump on new start up.*

- 2a. Pull and rotate Pivot knob to disengage the catalyst drive arm.

- b. Turn the slave pump yellow ball valve to the open position.

- c. Hand prime the pump until a steady stream of catalyst flows back to the bottle.

- d. Close the ball valve. Hand stroke the pump until it develops 50-60 PSI.

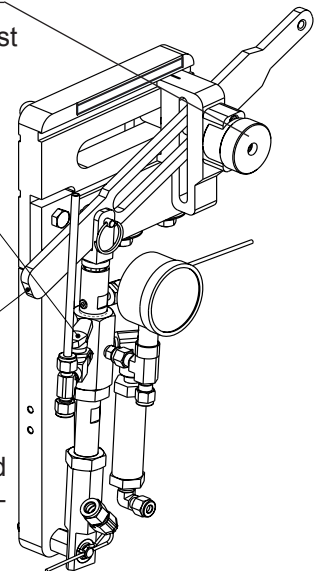

3. Set the slave pump to 3.5 percent.

## Start-Up



It is usually a general practice when starting up the system to let the system recirculate with the Catalyst Slave Pump set at 3.5%. This ensures good catalyst volume movement through the system to remove air in the catalyst system.

4. Re-engage the catalyst pivot knob.

### Notice

Make sure that the knob engages inside the catalyst drive arm slot. Failure to do so will cause damage to the catalyst drive arm.

## Recirculation Mode (Start-Up)

1. Both Catalyst Valve and Material Valve on the Dispense Gun should be in the Recirculation position.

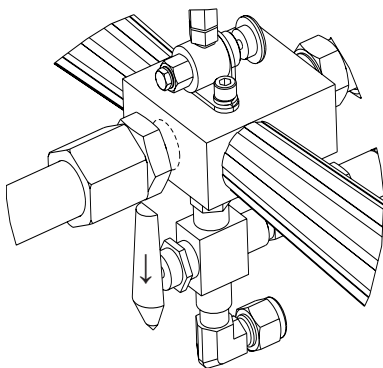
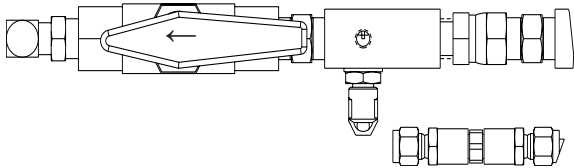

2. Switch machine recirculation to "ON".

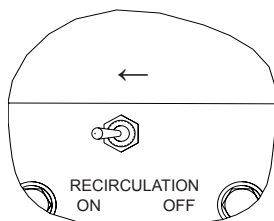

3. Turn air motor pressure regulator slowly clockwise until pump cycles slowly.

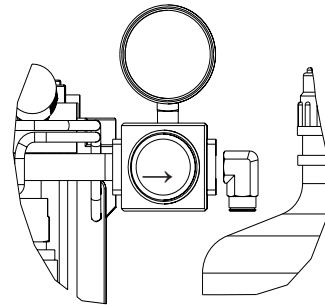

The Recirculation Mode should be used in initial start-up or when air bubbles are observed coming through the ends of the Recirculation Hoses.

## Injection Instructions

1. Switch machine to injection. (set recirculation to off)

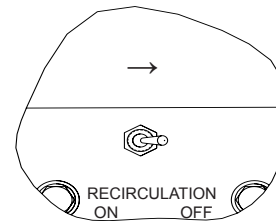

2. Turn valves on gun head to injection.

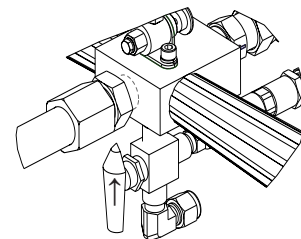
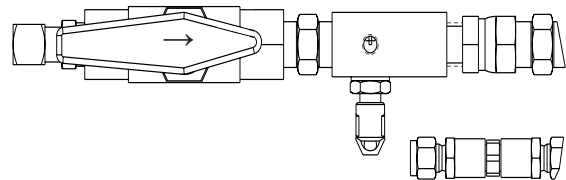



When making test material dispenses or during flushing operation, make certain that dispensed material and/or solvent is contained in a suitable container and that this material and/or solvent is disposed of properly.

# Start-Up

 Do not leave ball valves in injection position when not injecting. If ball valves are in injection position and recirculation is started material will be dispensed instead of recirculated.

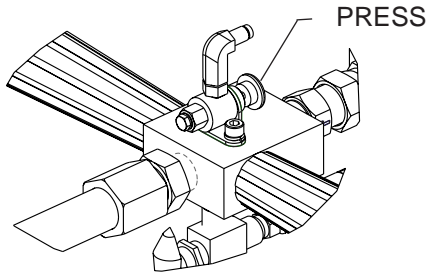



3. Select desired percentage of catalyst and position the catalyst slave pump to that setting.
4. Depress air switch button trigger on gun head to dispense mixed material.

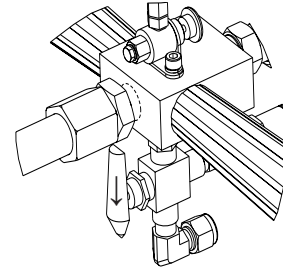
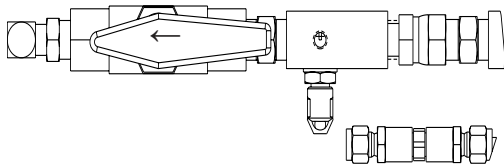

 When starting the machine, it is recommended to dispense a couple of strokes of resin into a suitable container to ensure a proper flow of materials. Also, test for proper gel and cure times.

5. Release air switch button trigger to stop material flow.
6. When finished, turn valves on gun head to recirculation position.



						
---	--	---	---	--	--	--

When making test material dispenses or during flushing operation, make certain that dispensed material and/or solvent is contained in a suitable container and that this material and/or solvent is disposed of properly.

7. Flush gun head thoroughly. Turn 3-way valve on top of the solvent tank so the arrow is pointing up for air purge, for solvent turn the valve so the arrow is pointing down.

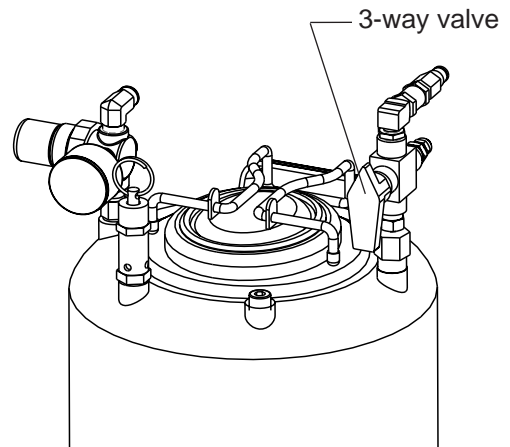
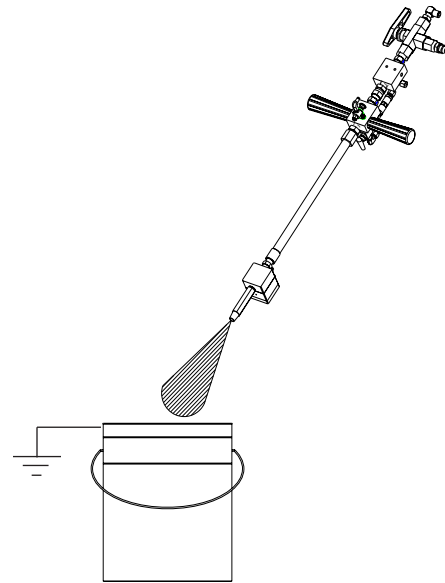





# Shut-Down

## Shut Down Procedure

The purpose of the shut down procedure is to verify that all critical parts of the system, i.e., the mixing area, have been checked and cleaned to assure trouble-free start-up the next time the system is to be operated.

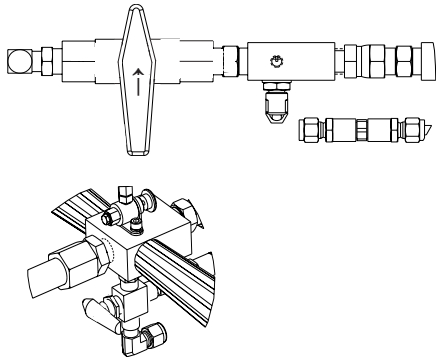
1. Turn both ball valves on gun head to "OFF". (90°)



 *If using a filled resin it is suggested that the material pump and hoses be flushed with a "neat" resin and that the neat resin is flowing through the system and exiting the material recirculation hose thoroughly before shut down procedures are completed.*

2. Flush gun head with solvent and air purge thoroughly.
3. Material pump should be stopped with pump shaft in up position and shaft should be cleaned of any contaminants.

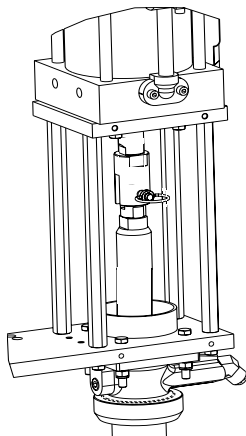

4. Material pump lube cup should be cleaned of old lube and refilled with new pump lube.

5. Material pump should now be cycled so that shaft is left in down position during shut-down period.

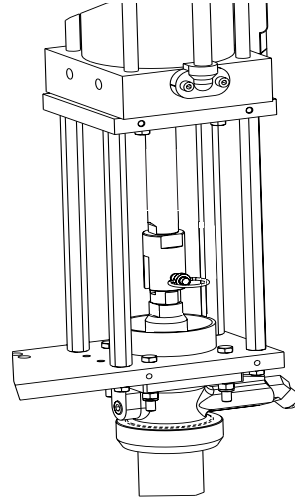

6. If you are using fillers mixed into the resin, remember on periods of shut-down, the fillers can settle to the bottom of the pump and pipe-works.
7. Shut down main air supply by closing yellow lock out valve.

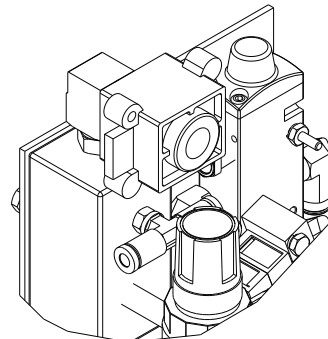

8. Slowly bleed the air pressure from the tank by lifting the ring on the relief valve.

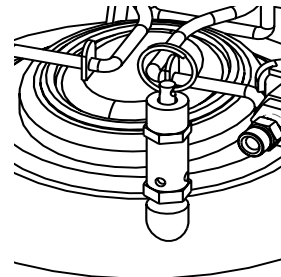

### Notice

*Failure to cycle Pump Shaft to DOWN position may result in contaminants to dry or harden on shaft. When pump is next operated, severe damage may be done to upper pump seals.*



## Parts

### Spartan System

<b>Standard Equipment</b>	
<b>Part Number</b>	<b>Description</b>
20864-07	MATERIAL PUMP ASSEMBLY, 13:1 RATIO
SSP-160-01	SUPER CATALYST SLAVE PUMP ASSEMBLY
21661-00	AIR LOGIC ASSEMBLY
20941-00	CATALYST BOTTLE ASSEMBLY
LPA-169	CATALYST BOTTLE BRACKET ASSEMBLY
18291-01 / 20569-01	BASE & MAST
21654-00	SOLVENT TANK ASSEMBLY
GAM-268-01	MATERIAL PUMP PICK-UP KIT
21694-25	MATERIAL HOSE ASSEMBLY, 25 FT.
20195-30	MATERIAL RECIRCULATION HOSE
17440-00	GROUNDING CLAMP ASSEMBLY
20190-30	CATALYST HOSE 30 FT.
20945-00	CATALYST RECIRCULATION HOSE
21054-01	SOLVENT HOSE 38 FT.
21668-00	GUN ASSEMBLY
GC-1202	MANUAL

# Assembly Drawings

## 21650-00 Unit Assembly

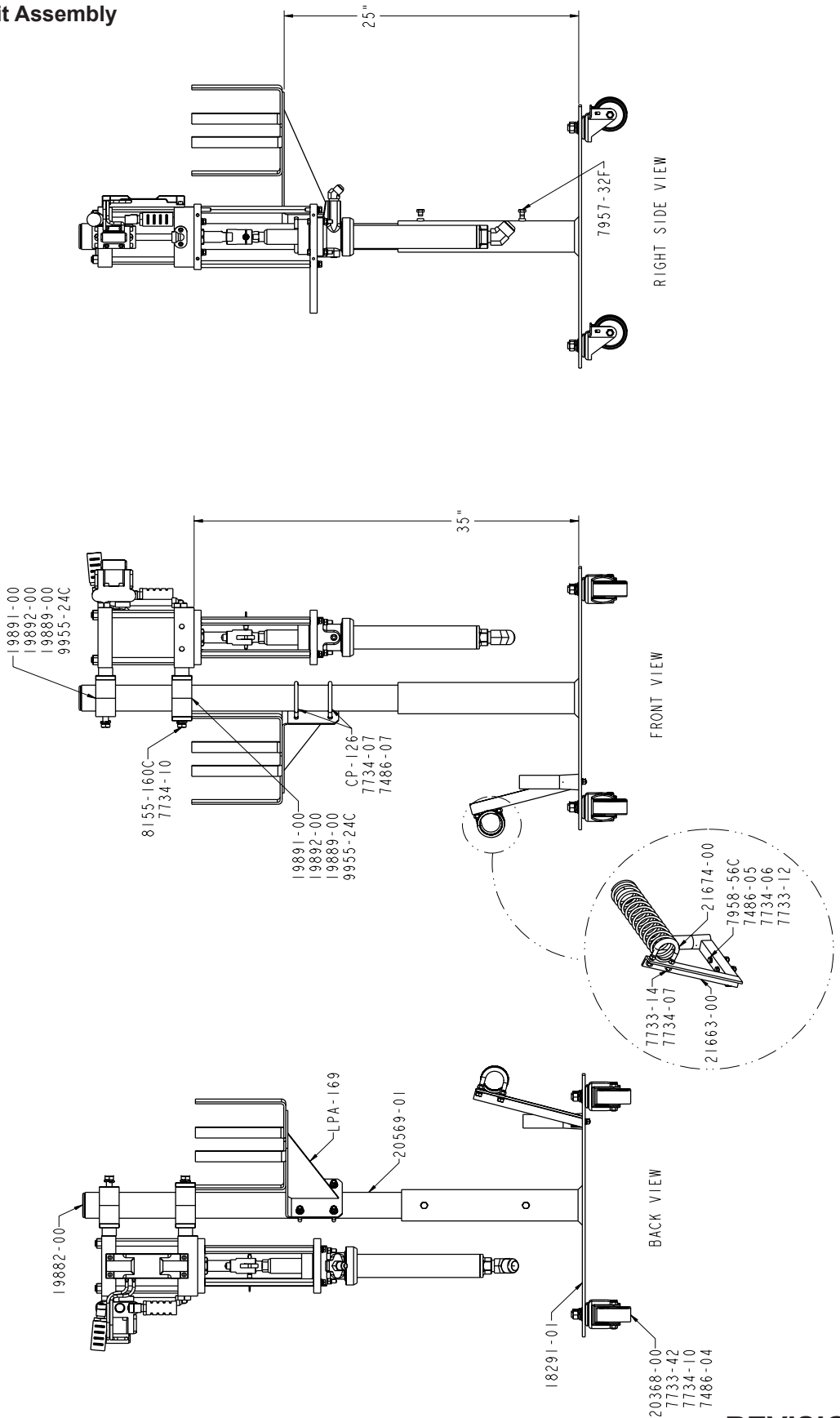

**REVISION ZAC**

# Assembly Drawings

## 21650-00 Unit Assembly

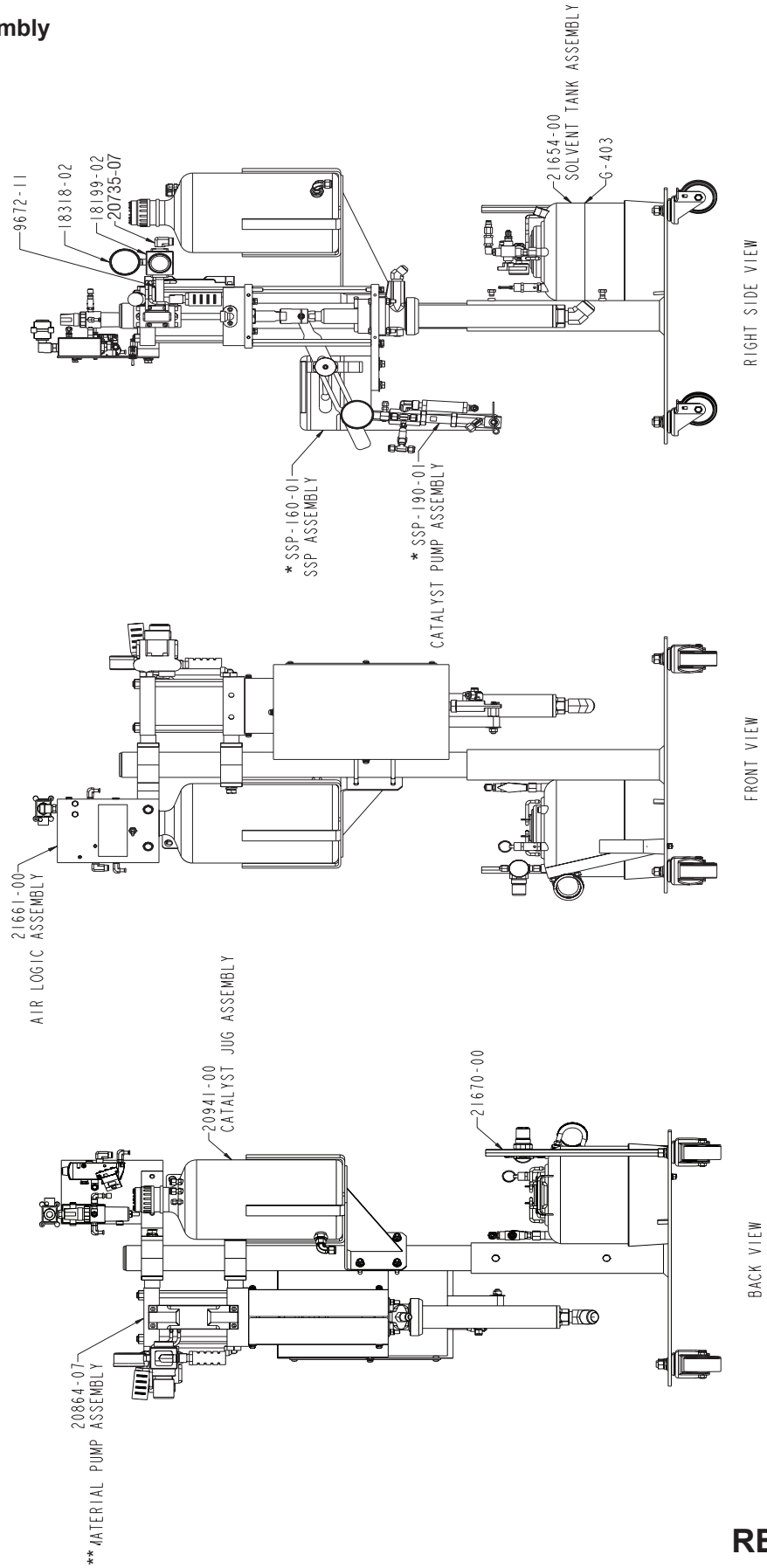

\* For a detailed view, see GC-1337

\*\* For a detailed view, see GC-1303

**REVISION ZAC**

# Assembly Drawings

## 21650-00 Unit Assembly

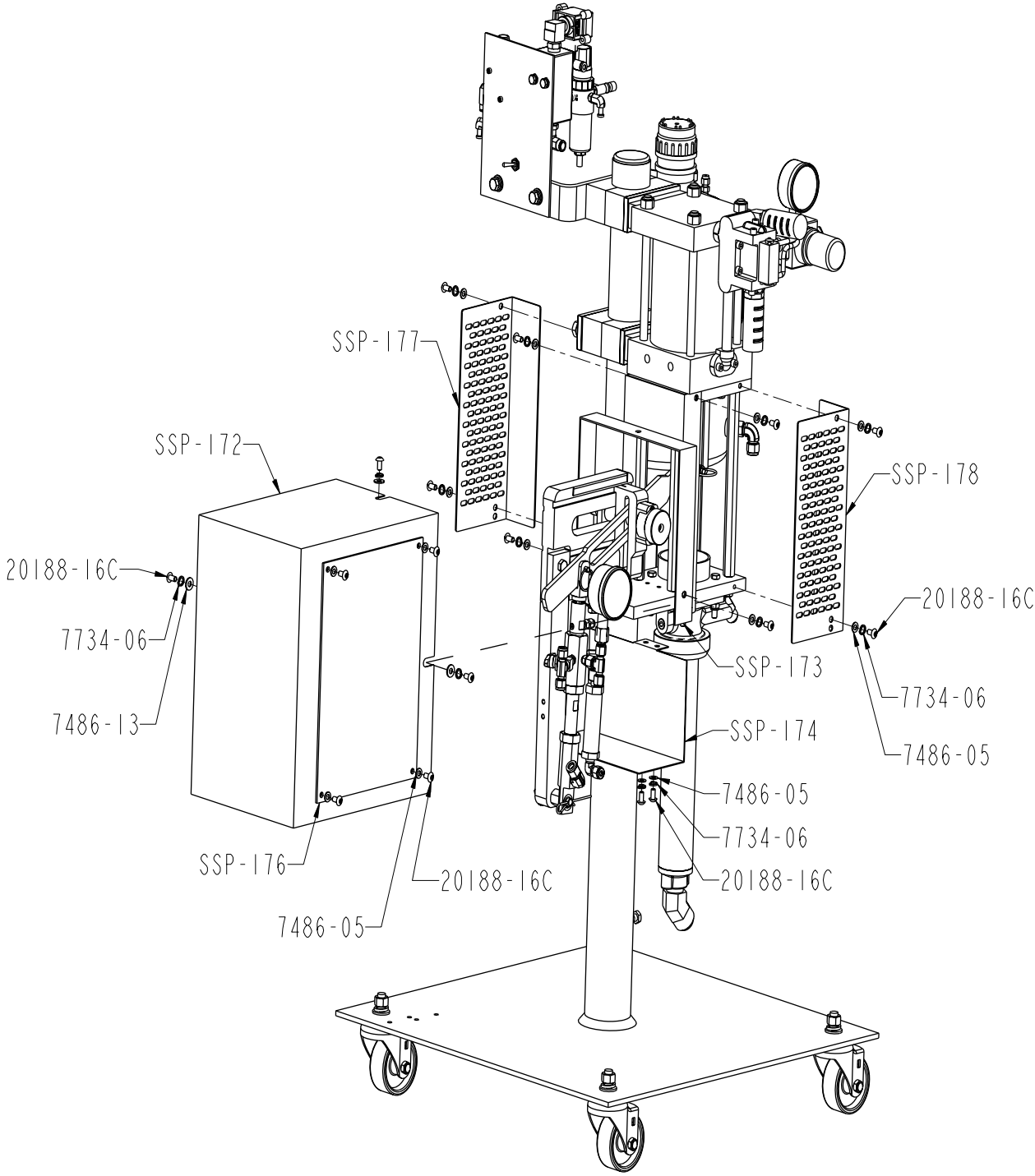

PARTS REMOVED FOR CLARITY

REVISION ZAC

# Assembly Drawings

## 21650-00 Assembly Hose Connections

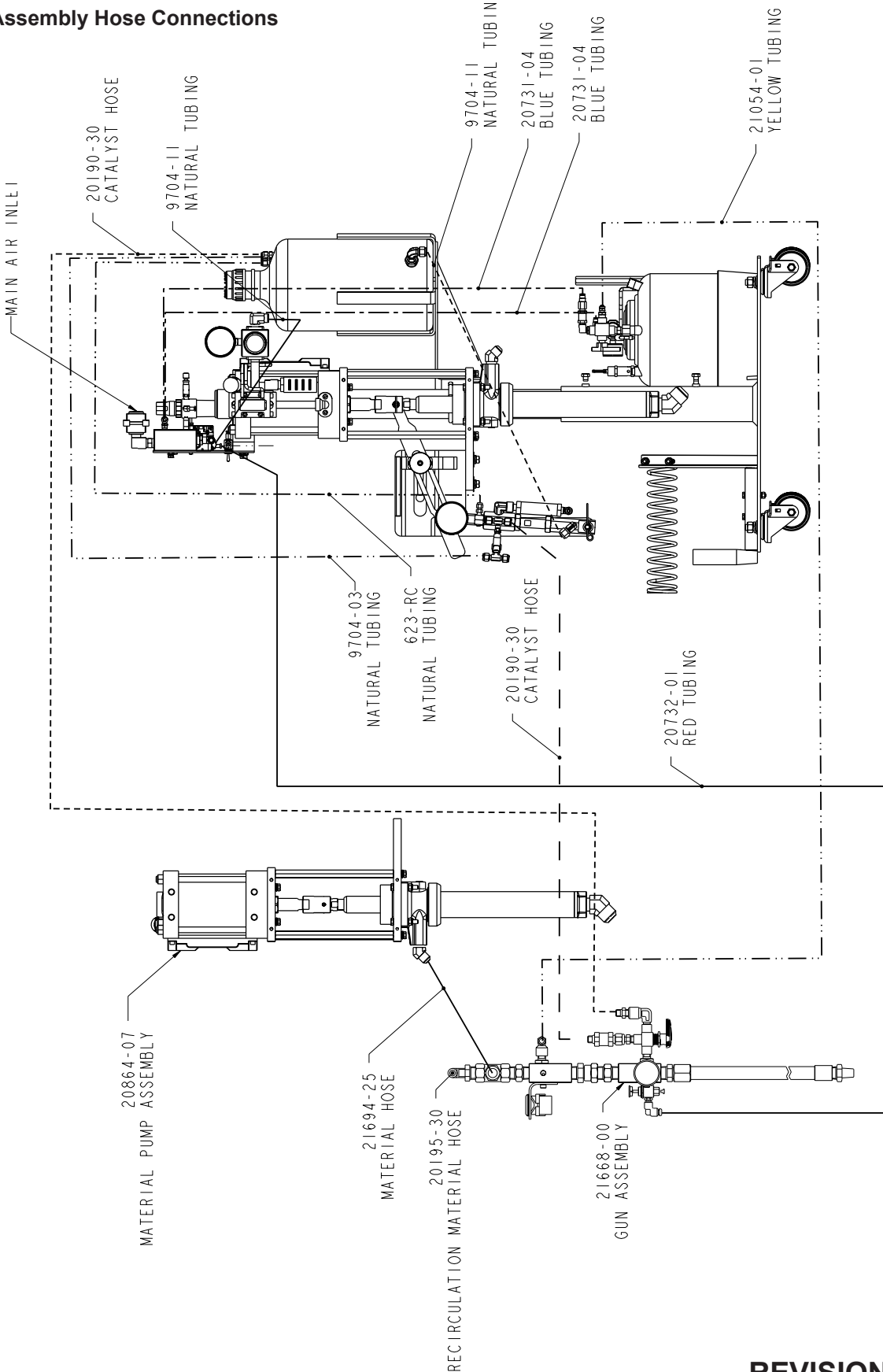

REVISION ZAC

# Assembly Drawings

## 21650-00 Gun Hoses

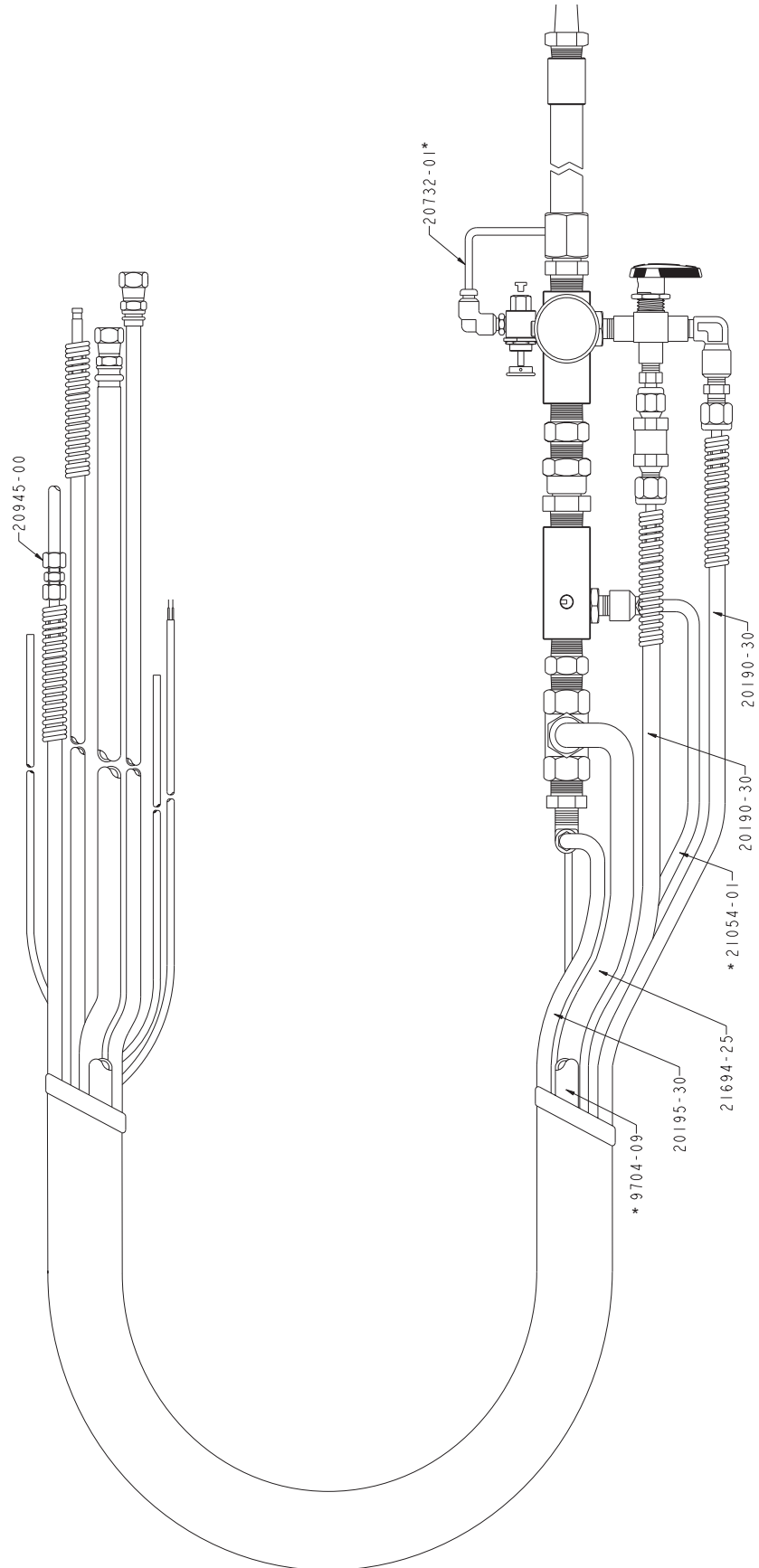

\* Part numbers 20732-01 and 21054-01 go inside of 9704-09.

**REVISION ZAC**

# Assembly Drawings

## 21650-00 Assembly Parts List

Part Number	Description	Qty.
13424-01	CABLE TIE	3
17440-00	GROUNDING CLAMP	1
18199-02	AIR REGULATOR	1
18291-01	FLOOR MOUNT BASE	1
18318-02	AIR GAUGE	1
19845-00	FRP LITERATURE	1
19882-00	MAST CAP	1
19889-00	MOUNTING ADAPTER	2
19891-00	PIPE CLAMP	2
19892-00	COVER PLATE	3
20188-16C	SCREW	17
20190-30	CATALYST HOSE	2
20195-30	RECIRCULATION MATERIAL HOSE	1
20368-00	CASTER	4
20569-01	SUPPORT MAST	1
20655-04	FITTING	1
20731-04	BLUE TUBING	7'
20732-01	RED TUBING	32'
20732-02	YELLOW TUBING	1.166'
20735-07	ELBOW FITTING	1
20864-07	MATERIAL PUMP ASSEMBLY	1
20941-00	CATALYST JUG	1
20945-00	RECIRCULATION ASSEMBLY	1
21054-01	NYLON TUBING	38'
21654-00	SOLVENT TANK	1
21661-00	AIR LOGIC ASSEMBLY	1
21663-00	MOUNTING BLOCK	1
21668-00	SPARTAN GUN	1
21670-00	TANK SUPPORT	1
21674-00	HOSE GUIDE	1
21694-25	MATERIAL HOSE ASSEMBLY	1
3923-02	SPIRAL WRAP	28'
7486-04	WASHER	4
7486-05	WASHER	16
7486-07	WASHER	4
7486-13	WASHER	3

Part Number	Description	Qty.
7733-12	NUT	2
7733-14	NUT	2
7733-42	NUT	4
7734-06	WASHER	15
7734-07	WASHER	6
7734-10	WASHER	8
7957-32F	SCREW	2
7958-56C	SCREW	2
8155-160C	SCREW	4
9672-11	FITTING	1
9704-09	NATURAL TUBING	25'
9704-11	NATURAL TUBING	9'
9955-24C	SCREW	4
CP-126	U-BOLT	2
G-403	STRAP	1
GAM-268-01	PICK-UP TUBE	1
GC-1202	USER MANUAL	1
LPA-169	BOTTLE SUPPORT ASSEMBLY	1
SSP-157-01	DECAL	1
SSP-160-01	SLAVE PUMP ASSEMBLY	1
SSP-172	GUARD	1
SSP-173	GUARD	1
SSP-174	BRACKET	1
SSP-176	GUARD WINDOW	1
SSP-177	GUARD	1
SSP-178	GUARD	1

**REVISION W**

# Sub-Assembly Drawings

## 21661-00 Air Logic Assembly

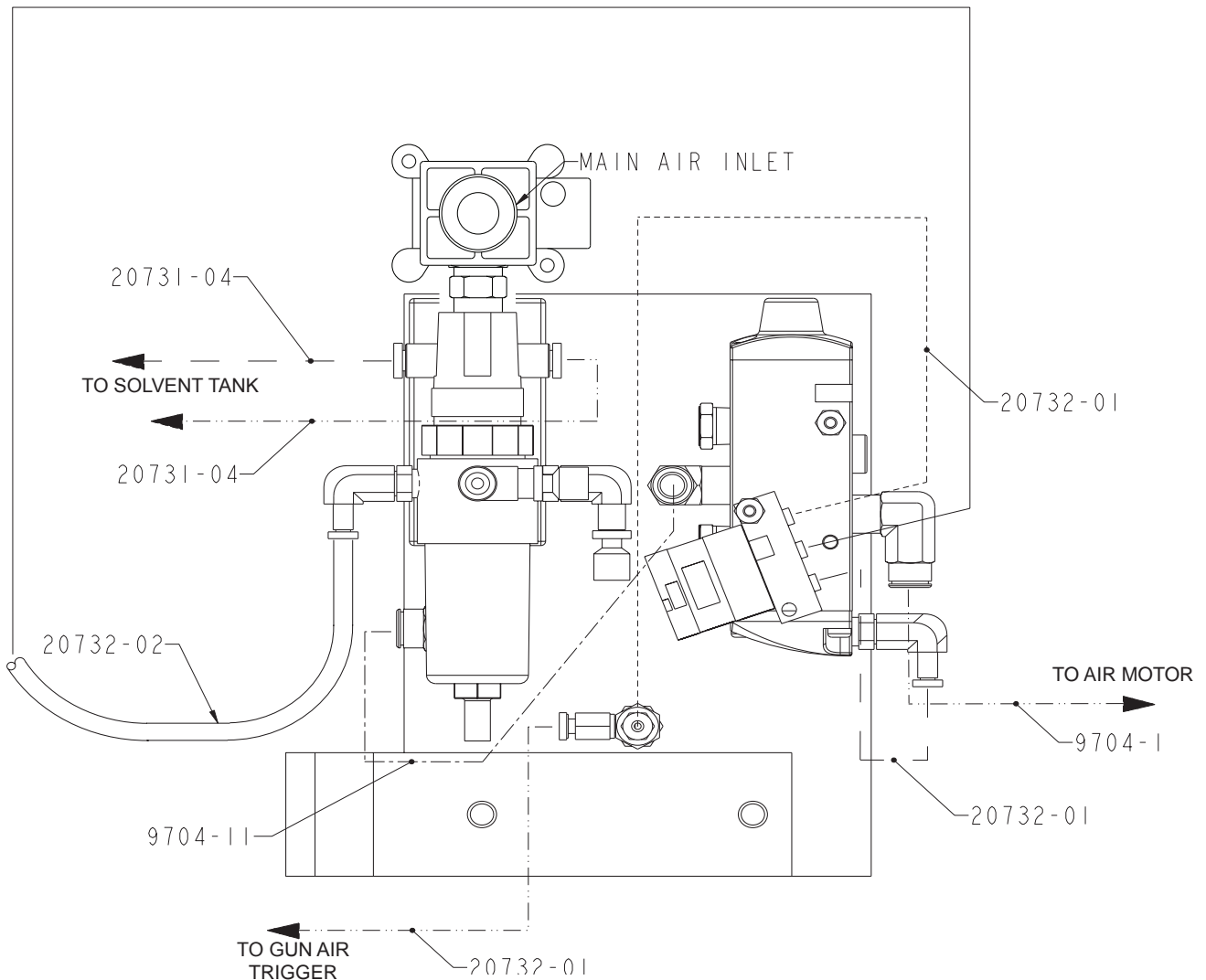
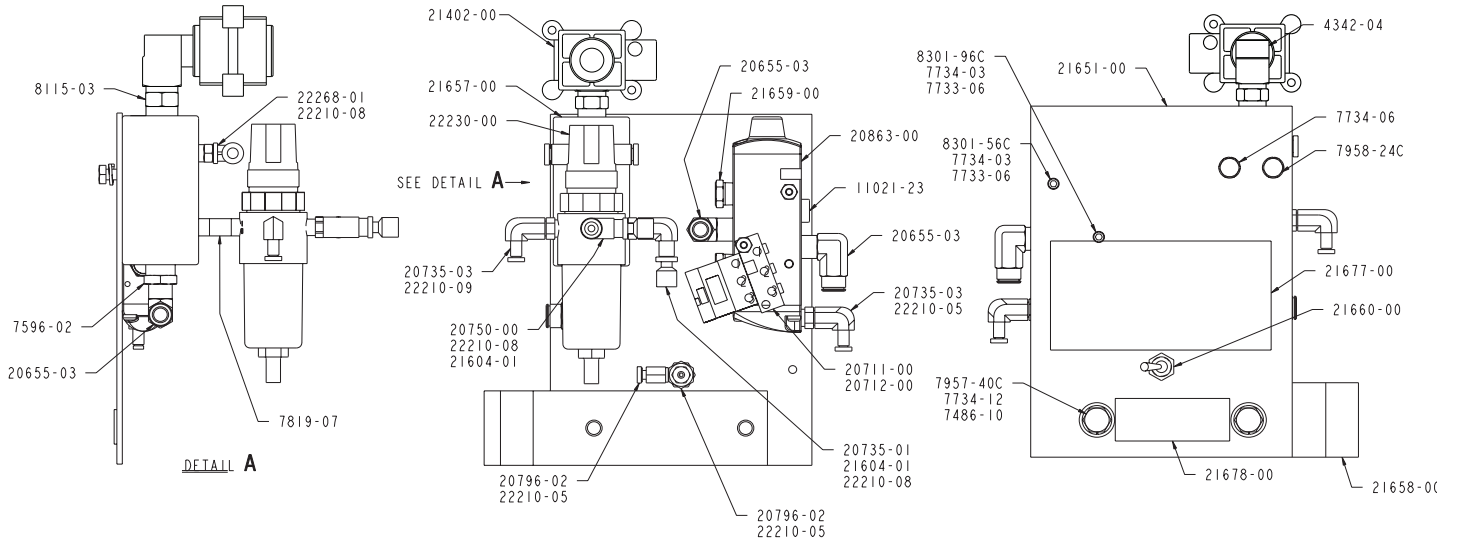

**REVISION S**

GC-1202E



# Sub-Assembly Drawings

## 21668-00 Spartan Gun Assembly

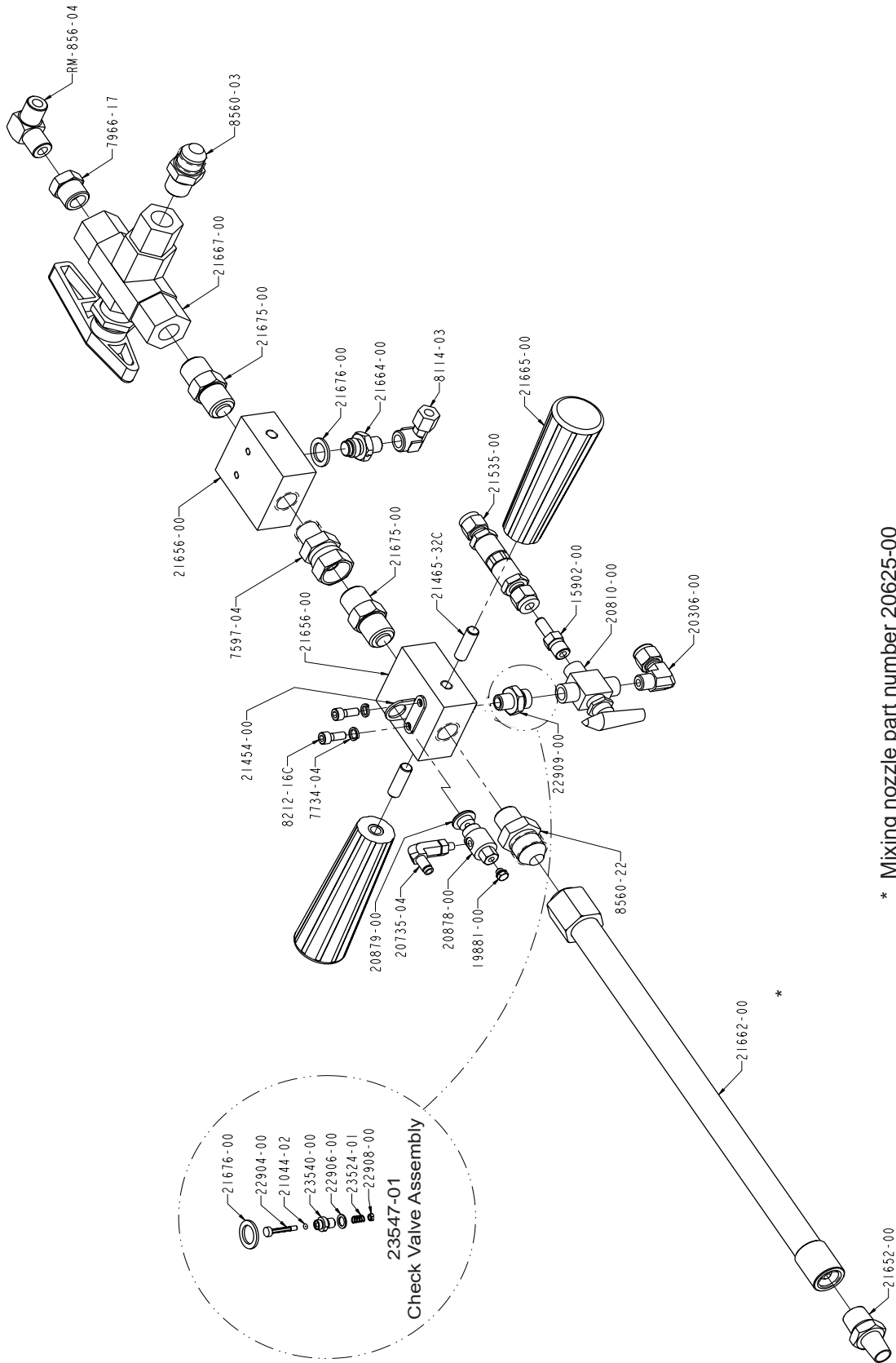

\* Mixing nozzle part number 20625-00 is included with 21662-00  
 \*\* 22909-00 is not included with 23547-01

**REVISION E**

## Sub-Assembly Drawings

### 21668-00 Spartan Gun Parts List

<b>Part Number</b>	<b>Description</b>	<b>Qty.</b>
15902-00	FITTING	1
19881-00	PLUG	1
20306-00	FITTING	1
20735-04	FITTING	1
20810-00	BALL VALVE	1
20878-00	VALVE	1
20879-00	PUSH BUTTON	1
21044-02	O-RING	1
21454-00	BRACKET	1
21465-32C	STUD	2
21535-00	CHECK VALVE	1
21652-00	NOZZLE	1
21656-00	BLOCK	2
21662-00	INJECTION WAND	1
21664-00	CHECK VALVE	1
21665-00	HANDLE	2
21667-00	BALL VALVE	1
21675-00	CHECK VALVE	2
21676-00	WASHER	2
22904-00	VALVE STEM	1
22906-00	WASHER	1
22908-00	NUT	1
22909-00	VALVE BODY	1
23524-01	SPRING	1
23540-00	VALVE BODY	1
7597-04	FITTING	1
7734-04	WASHER	2
7966-17	FITTING	1
8114-03	FITTING	1
8212-16C	SCREW	2
8560-03	FITTING	1
8560-22	FITTING	1
RM-856-04	FITTING	1

**REVISION E**

# Sub-Assembly Drawings

## GAM-268-01 Material Pick-Up Kit

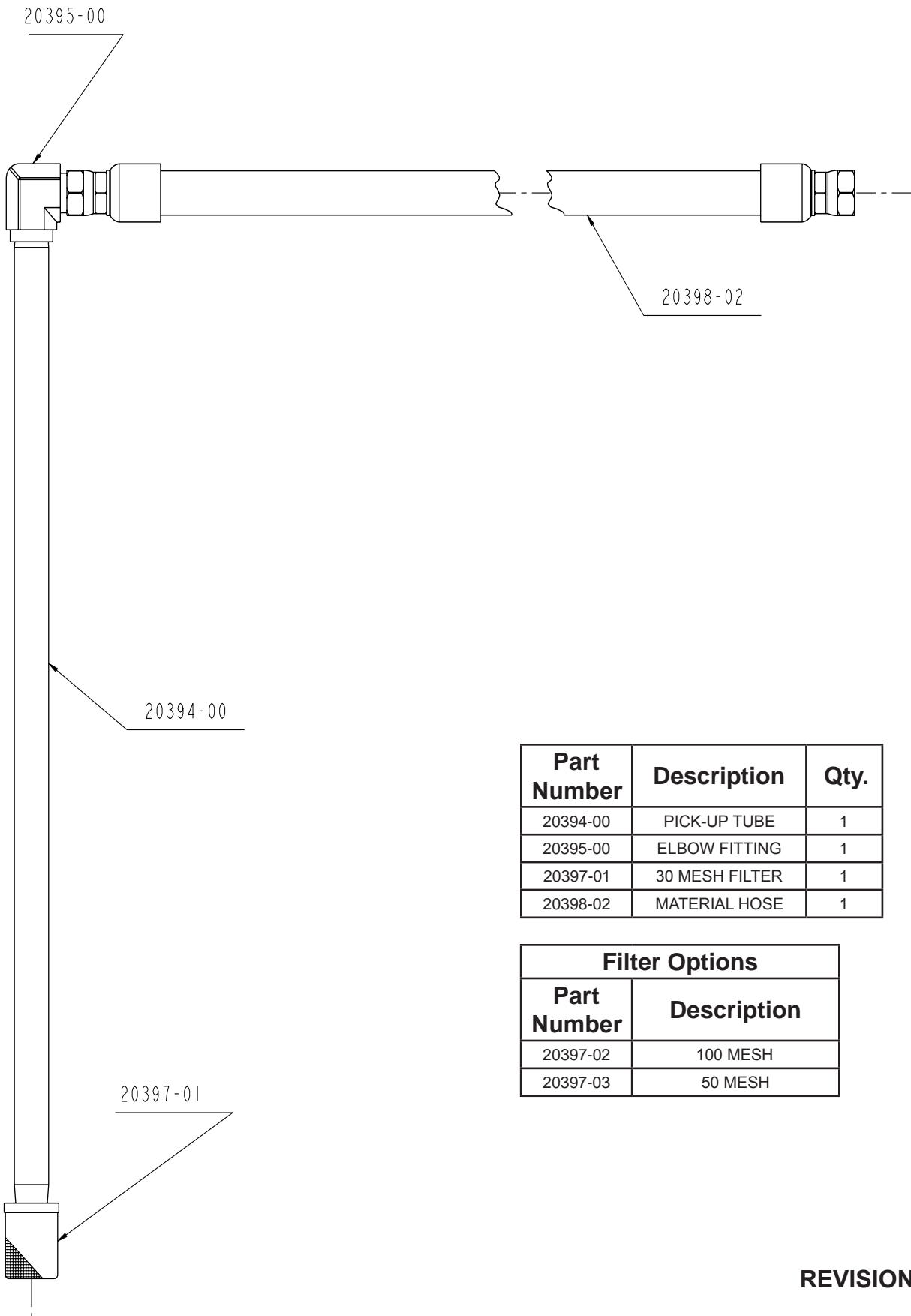

Part Number	Description	Qty.
20394-00	PICK-UP TUBE	1
20395-00	ELBOW FITTING	1
20397-01	30 MESH FILTER	1
20398-02	MATERIAL HOSE	1

Filter Options	
Part Number	Description
20397-02	100 MESH
20397-03	50 MESH

REVISION D

# Sub-Assembly Drawings

## 20941-00 Catalyst Bottle Assembly

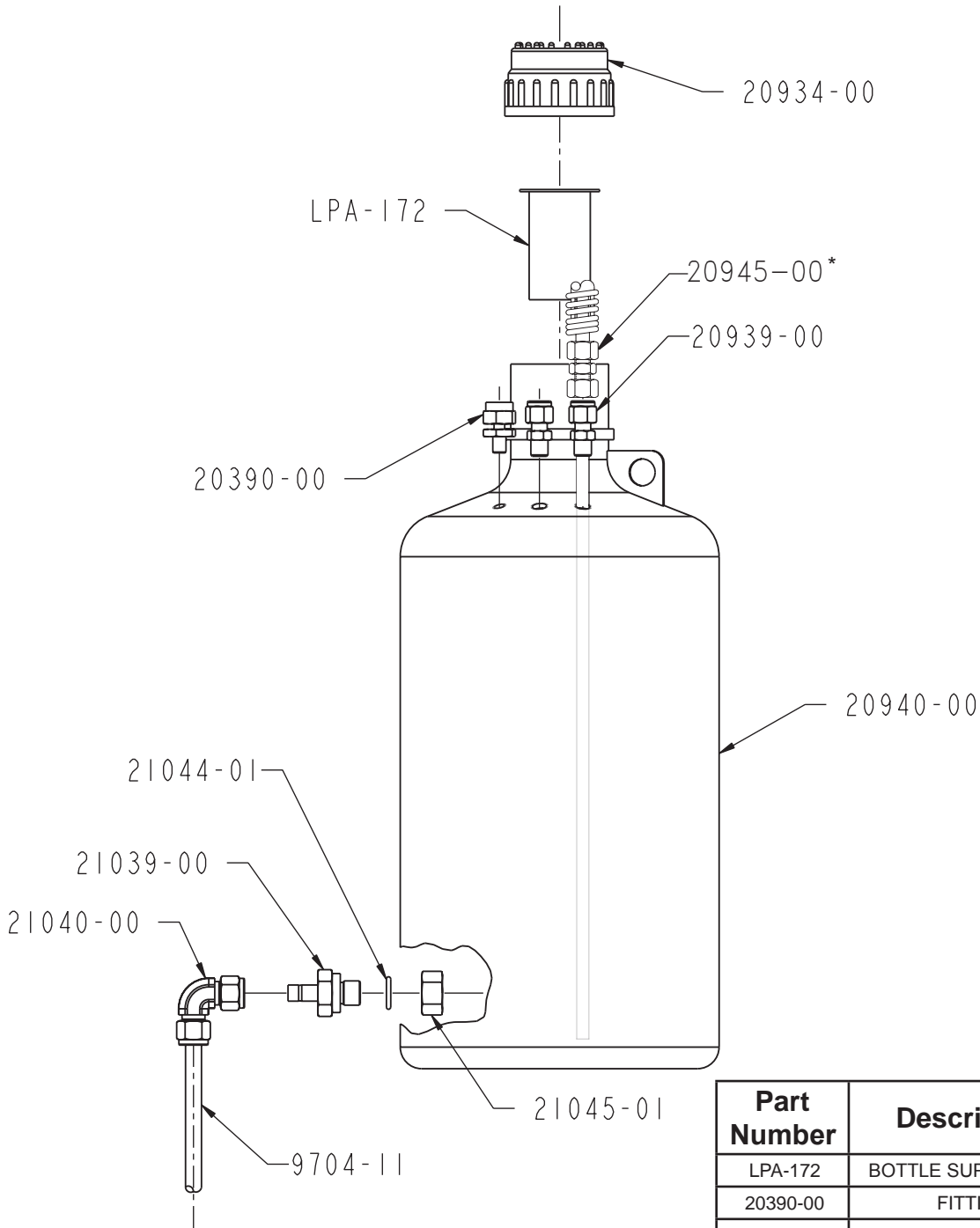

Part Number	Description	Qty.
LPA-172	BOTTLE SUPPLY FILTER	1
20390-00	FITTING	1
20934-00	JUG CAP	1
20939-00	MALE CONNECTOR	2
20940-00	SUPPLY BOTTLE	1
21039-00	FITTING	1
21040-00	ELBOW FITTING	1
21045-01	HEX NUT	1
9704-11	NATURAL TUBING	5'

\* Shown for connection purposes only.  
Not included with 20941-00 assembly.

**REVISION G**

# Sub-Assembly Drawings

## 21654-00 Solvent Tank Assembly

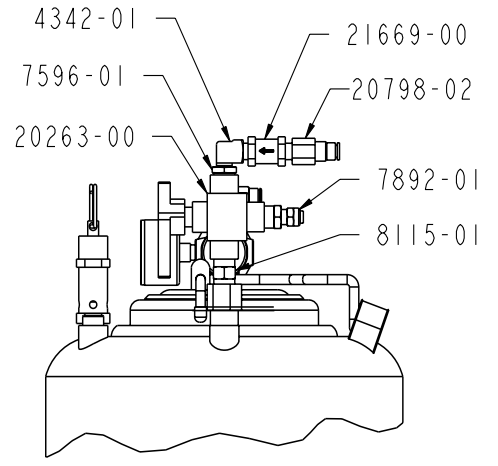
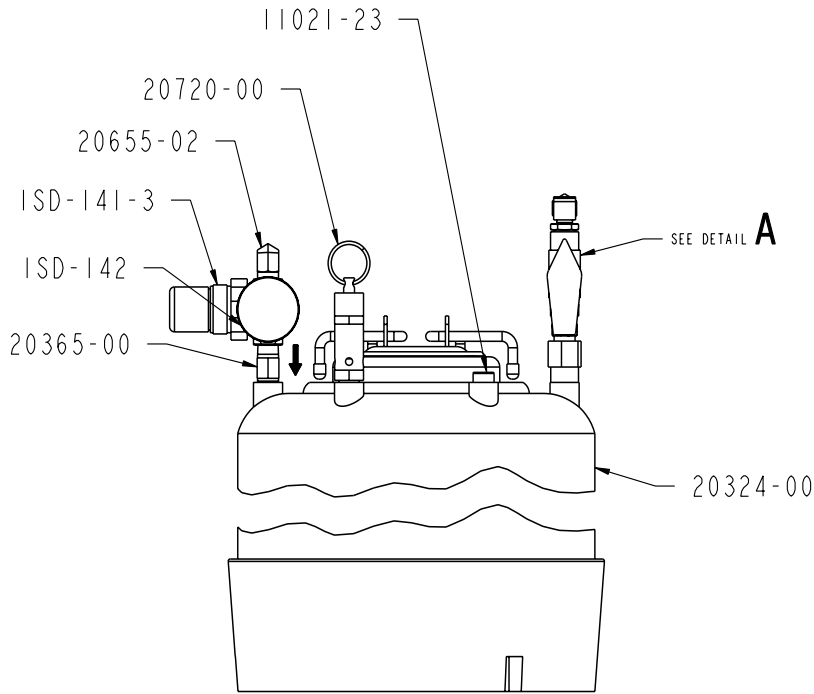

DETAIL A

Part Number	Description	Qty.
ISD-141-3	MINI REGULATOR	1
ISD-142	SOLVENT POT GAUGE	1
11021-23	PIPE PLUG	1
20263-00	VALVE	1
20324-00	SOLVENT TANK	1
20365-00	VALVE	1
20655-02	ELBOW FITTING	1
20720-00	VALVE	1
20798-02	FITTING	1
21669-00	CHECK VALVE	1
4342-01	ELBOW FITTING	1
7596-01	FITTING	1
7892-01	FITTING	1
8115-01	FITTING	1
21044-06	SILICONE O-RING	1

Optional		
Part Number	Description	Qty.
13867-68	EPR O-RING	1

REVISION D

## Maintenance

						
<p>Before performing any maintenance on this system - Follow pressure relief procedures on page 8.</p>						

### Notice

Due to the different o-ring materials and lubricants used in the dispense guns never submerge or soak any dispense gun in any type of solvent. Submerging or soaking any dispense gun will immediately void the gun warranty.

## Maintenance

It is recommended that the following service be performed on a weekly basis.

1. Inspect and lubricate Catalyst Slave Pump Linkage. (See Catalyst Slave Pump User Manual.)
2. Inspect Pump Shafts on Material and Catalyst Pumps, making certain they are clean and free of foreign material. Clean and lubricate as required.

For long term storage of your injection system, it is recommended that the following procedures be followed:

1. Place dry nitrogen in the material drums and secure drum.
2. Make certain all air and material valves are in their "OFF" position.



*GlasCraft recommends that you contact your gel-coat and/or resin supplier concerning material pot-life during extended periods of shut-down. The decision as to whether or not to leave material in your system should be based on information from your material suppliers as well as GlasCraft.*

*Consult your local authorized GlasCraft distributor for more information concerning system storage.*

## Troubleshooting



*Before altering catalyst percentage by moving the catalyst pump to a new desired location on the ratio arm ALWAYS ensure that the catalyst recirculation valve is turned to the recirculation position, and the air pressure is removed from the system.*

It is absolutely essential that both streams of material are pumped to the head without air or gas entrapped. For example, if air is drawn into the resin stream through the resin pump inlet system, i.e., via bad connection or filter end coming out of resin surface, then this air if not purged out of the machine by recirculating on by-pass will naturally go to the head through the mixer and into the RTM mold. This fault condition will manifest itself in the molded part having very small bubbles; almost in a froth like state, on the upper side of the

molded part once the mold is opened. The reason for these bubbles being so small is due to the fact that air coming through the mixer with the resin is mixed and frothed before finally entering the mold.

Air or gas in the catalyst stream, leads to a different type of fault in the molded part. This condition will be manifest by observing when opening the mold after injection and supposed cure, that there are wet patches of uncured or semi-gelled resin in the molded part. The causes attributed to this are:

1. Air is drawn in by the catalyst pump through a bad connection on the inlet stream from the catalyst container or pump inlet connection.
2. Catalyst contamination in the pump system causing oxidation resulting in peroxide gas bubbles being generated within the supposedly hydraulic sealed system of the catalyst.
3. The catalyst pump has faulty seals or is contaminated with particles.

To ensure that the catalyst system is totally hydraulically tight, it is expedient after a period of shut-down that the procedures in the instructions for commissioning the catalyst stream should be repeated.

## Technical Data

Category	Data
Maximum Fluid Working Pressure	1300 psi (9 MPa, 90 bar)
Maximum Air Inlet Pressure	100 psi (0.7 MPa, 7 bar)
Typical Flow Rate of Pattern Guns	Refer to gun manual
Maximum Fluid Temperature	100° F (38° C)
B Component (Resin) Inlet Size	1 5/16-12 UN-2A Male
Sound Pressure	84.83 dB(A)
Sound Power, measured per ISO 94 16-2	87.04 dB(A)
Dimensions	30 L X 30 W X 59 H ( 762 X 762 X 1498.6 mm)
Weight	225 Lbs. (103 kg)
Wetted Parts	Catalyst- Chemically coated aluminum, stainless steel, chemically resistant o-rings Resin- Carbon steel, carbide, chemically resistant o-rings.

# Graco Standard Warranty

Graco warrants all equipment referenced in this document which is manufactured by Graco and bearing its name to be free from defects in material and workmanship on the date of sale to the original purchaser for use. With the exception of any special, extended, or limited warranty published by Graco, Graco will, for a period of twelve months from the date of sale, repair or replace any part of the equipment determined by Graco to be defective. This warranty applies only when the equipment is installed, operated and maintained in accordance with Graco's written recommendations.

This warranty does not cover, and Graco shall not be liable for general wear and tear, or any malfunction, damage or wear caused by faulty installation, misapplication, abrasion, corrosion, inadequate or improper maintenance, negligence, accident, tampering, or substitution of non-Graco component parts. Nor shall Graco be liable for malfunction, damage or wear caused by the incompatibility of Graco equipment with structures, accessories, equipment or materials not supplied by Graco, or the improper design, manufacture, installation, operation or maintenance of structures, accessories, equipment or materials not supplied by Graco.

This warranty is conditioned upon the prepaid return of the equipment claimed to be defective to an authorized Graco distributor for verification of the claimed defect. If the claimed defect is verified, Graco will repair or replace free of charge any defective parts. The equipment will be returned to the original purchaser transportation prepaid. If inspection of the equipment does not disclose any defect in material or workmanship, repairs will be made at a reasonable charge, which charges may include the costs of parts, labor, and transportation.

THIS WARRANTY IS EXCLUSIVE, AND IS IN LIEU OF ANY OTHER WARRANTIES, EXPRESS OR IMPLIED, INCLUDING BUT NOT LIMITED TO WARRANTY OF MERCHANTABILITY OR WARRANTY OF FITNESS FOR A PARTICULAR PURPOSE.

Graco's sole obligation and buyer's sole remedy for any breach of warranty shall be as set forth above. The buyer agrees that no other remedy (including, but not limited to, incidental or consequential damages for lost profits, lost sales, injury to person or property, or any other incidental or consequential loss) shall be available. Any action for breach of warranty must be brought within two (2) years of the date of sale.

GRACO MAKES NO WARRANTY, AND DISCLAIMS ALL IMPLIED WARRANTIES OF MERCHANTABILITY AND FITNESS FOR A PARTICULAR PURPOSE, IN CONNECTION WITH ACCESSORIES, EQUIPMENT, MATERIALS OR COMPONENTS SOLD BUT NOT MANUFACTURED BY GRACO. These items sold, but not manufactured by Graco (such as electric motors, switches, hose, etc.), are subject to the warranty, if any, of their manufacturer. Graco will provide purchaser with reasonable assistance in making any claim for breach of these warranties. In no event will Graco be liable for indirect, incidental, special or consequential damages resulting from Graco supplying equipment hereunder, or the furnishing, performance, or use of any products or other goods sold hereto, whether due to a breach of contract, breach of warranty, the negligence of Graco, or otherwise.

## FOR GRACO CANADA CUSTOMERS

The Parties acknowledge that they have required that the present document, as well as all documents, notices and legal proceedings entered into, given or instituted pursuant hereto or relating directly or indirectly hereto, be drawn up in English. Les parties reconnaissent avoir convenu que la rédaction du présente document sera en Anglais, ainsi que tous documents, avis et procédures judiciaires exécutés, donnés ou intentés, à la suite de ou en rapport, directement ou indirectement, avec les procédures concernées.

## Graco Information

For the latest information about Graco products, visit [www.graco.com](http://www.graco.com).

**TO PLACE AN ORDER**, contact your Graco distributor or call to identify the nearest distributor.

**Phone:** 1-800-746-1334 **or Fax:** 1-330-966-3006

*All written and visual data contained in this document reflects the latest product information available at the time of publication. Graco reserves the right to make changes at any time without notice.*

*Original instructions. This manual contains English. MM GC-1202*

**Graco Headquarters:** Minneapolis

**International Offices:** Belgium, China, Japan, Korea

**GRACO INC. AND SUBSIDIARIES ● P.O. BOX 1441 ● MINNEAPOLIS MN 54440-1441 ● USA**

Copyright 2008, Graco Ohio Inc. All Graco manufacturing locations registered to ISO 9001.

[www.graco.com](http://www.graco.com)

Revised 10/2011