

39003 Series

Masonellan* High Performance Butterfly Valves
(HPBV)



Table of Contents

Foreword.....	3	Rated Flow Coefficients (C_v) and Pressure Recovery Coefficients (F_L).....	12
Features.....	4	Standard Valve Components.....	14
Numbering System.....	5	Allowable Pressure Drops.....	16
General Data.....	7	Weights.....	17
Pressure/Temperature Ratings.....	8	Dimensions.....	19
Body Assembly Data.....	10	GE Sales Offices.....	Back Cover
Actuator Data.....	11		

Foreward

GE's Masoneilan 39003 Series High Performance Butterfly Valve (HPBV) is a heavy duty automatic throttling control valve that incorporates the two basic features of the HPBV types. These features differentiate the the Masoneilan* 39003 Series HPBV from the conventional swing-through butterfly valve in regards to sealing method and operational characteristics. Specifically, the two basic features are: (1) A PTFE, RTFE, or metal seal ring instead of a liner, and (2) The employment of double offset (eccentric operation). Each of these features contributes to the improved performance of HPBV's compared to conventional butterfly valves.

The use of a seal ring (PTFE, RTFE, or metal) eliminates the inherent problems of high sealing forces, due to interference fit, and the resultant high wear rates due to scraping and scuffing of liners. Also, due to the design of the seal itself, which is a dynamic pressure-assisted member, ANSI Class VI shutoff rates are available throughout the full range of ANSI Class 150, 300 and 600 ratings (soft-sealed constructions only).

The double offset (eccentric) operating principles of both seal offset (the seal ring centerline is offset from the shaft centerline – see Figure 1) and shaft offset (the shaft centerline is offset from the valve centerline – see Figure 1) allows the disc to get off the seal quickly due to the camming rotation with respect to the valve/seal centerlines. This results in minimal sliding (friction producing) contact between the disc and the seal ring with complete separation after only a few degrees of rotation.

The overall characteristics of the Masoneilan* 39003 Series Valve are listed below:

- **Long seal life** – Offset (eccentric) operation gets the disc off the seal quickly, minimizing sliding contact and friction, resulting in reduced seal wear and lower breakaway and seating torque requirements.
- **Fast/dynamic operation** – Offset (eccentric) operation eliminates disc-to-seal friction throughout the operating range resulting in fast response to input signals. Also, the disc tends to move in the direction of flow, assisting the valve and actuator to maximize the allowable operating pressures.
- **Excellent flow characteristics** – the offset (eccentric) disc design provides an approximate equal percentage flow characteristic through its full travel of 90° rotation yielding a C_v ratio of 100:1.
- **Extra heavy shafts with keyed ends for actuator mounting** – precise and accurate positioning without lost motion or back-

lash.

PTFE-lined low-friction bearing – Reduces operating torque and promotes fast response to valve and actuator action. The triple bearing support of the shaft prevents deflection of the shaft due to side-loading.

Field replaceable components – Unlike most competitive valves, shaft and disc need not be purchased as a set. The Masoneilan* 39003 Series Valve uses tapered pins to attach the shaft and disc positively, yet provide component interchangeability.

Trade names noted throughout are for reference only. GE reserves the right to supply trade named material or its equivalent.

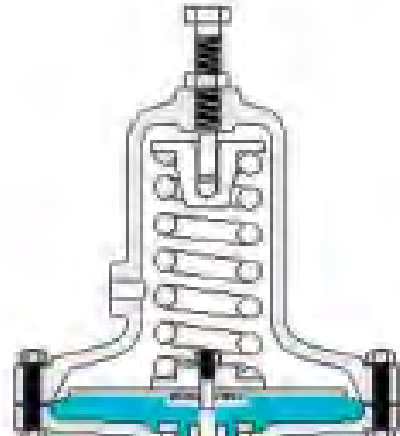

Features

GE's Masoneilan 39003 Series HPBV includes unique valve seal designs for metal, soft seal, and fire-safe configurations.

Metal Seal Design

The metal seal design incorporates an Inconel seal for higher tensile strength, a 300 series stainless steel back-up ring in the seal cavity for axial seal support, and a disc that is case hardened by nitriding.

The Inconel seal, by its dynamic and flexible design, applies enough force per linear inch against the disc edge (Rockwell Hardness of C66 to C70) to obtain an optimum sealing characteristic while controlling the loads between the metal surfaces.

The metal seal design can be utilized for temperatures up to 900°F, in compliance with ANSI B16.34 pressure/temperature specifications. Leakage is rated at Class IV per ANSI FCI 70-2.

Soft Seal Design

The soft seal design provides a bi-directional bubble tight shutoff (zero leakage) through the use of a patented seal. This unique seal design creates a self-energized seal in vacuum-to-low pressure applications.

Under higher pressure conditions, the seal is also designed to confine and direct movement of the soft seal against the disc edge, up to the full ANSI Class 150, 300 and 600 Cold Working Pressures.

The soft seal is designed for high services with minimal wear and low torque. Seal replacement is a simple procedure requiring no special tools.

Fire-Safe Seal Design

The fire-safe seal design incorporates two patented seals which function together to seal off pipeline flow. In normal operation, the soft seal provides a bi-directional "bubble tight" shutoff (zero leakage); the metal seal provides bi-directional shutoff in the event of a fire, in conformance to industry fire-safe requirements.

With little or no pressure, the fire-safe seal creates a self-energized seal against the disc. Higher line pressures act on the geometry of both seals to dynamically load them against the disc, creating higher sealing forces in either direction.

The metal seal is made of Inconel material which is shaped by a proprietary hydroforming process into its unique, patented design. Stainless steel outer bearings are included for post-fire disc and shaft alignment. Fireproof packing is used to prevent external shaft leakage.

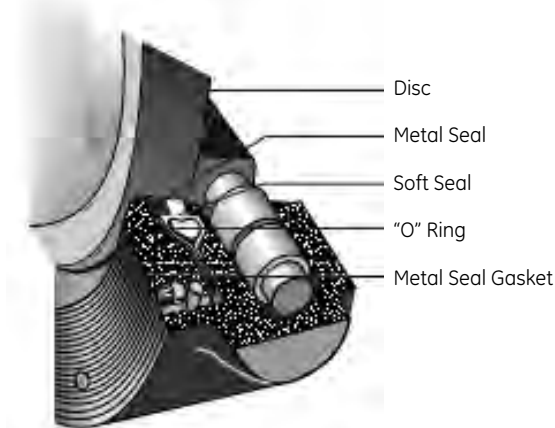
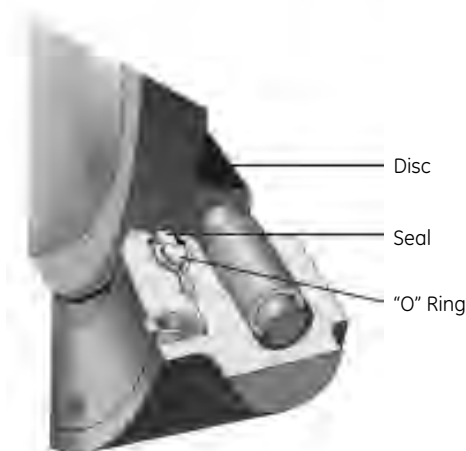
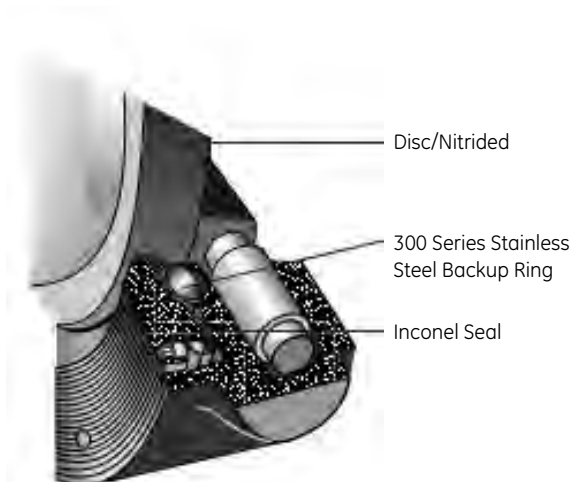

Numbering System

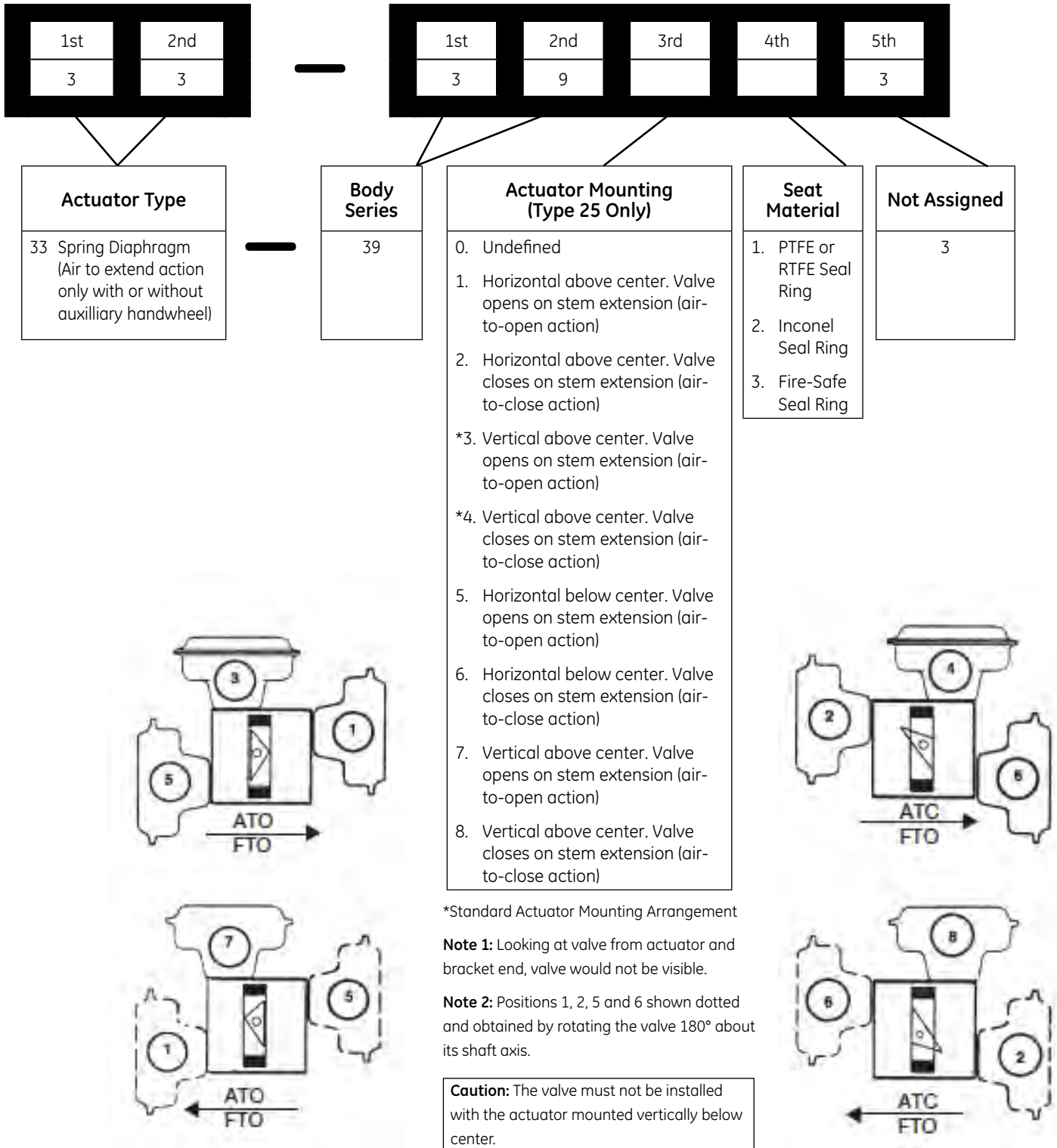
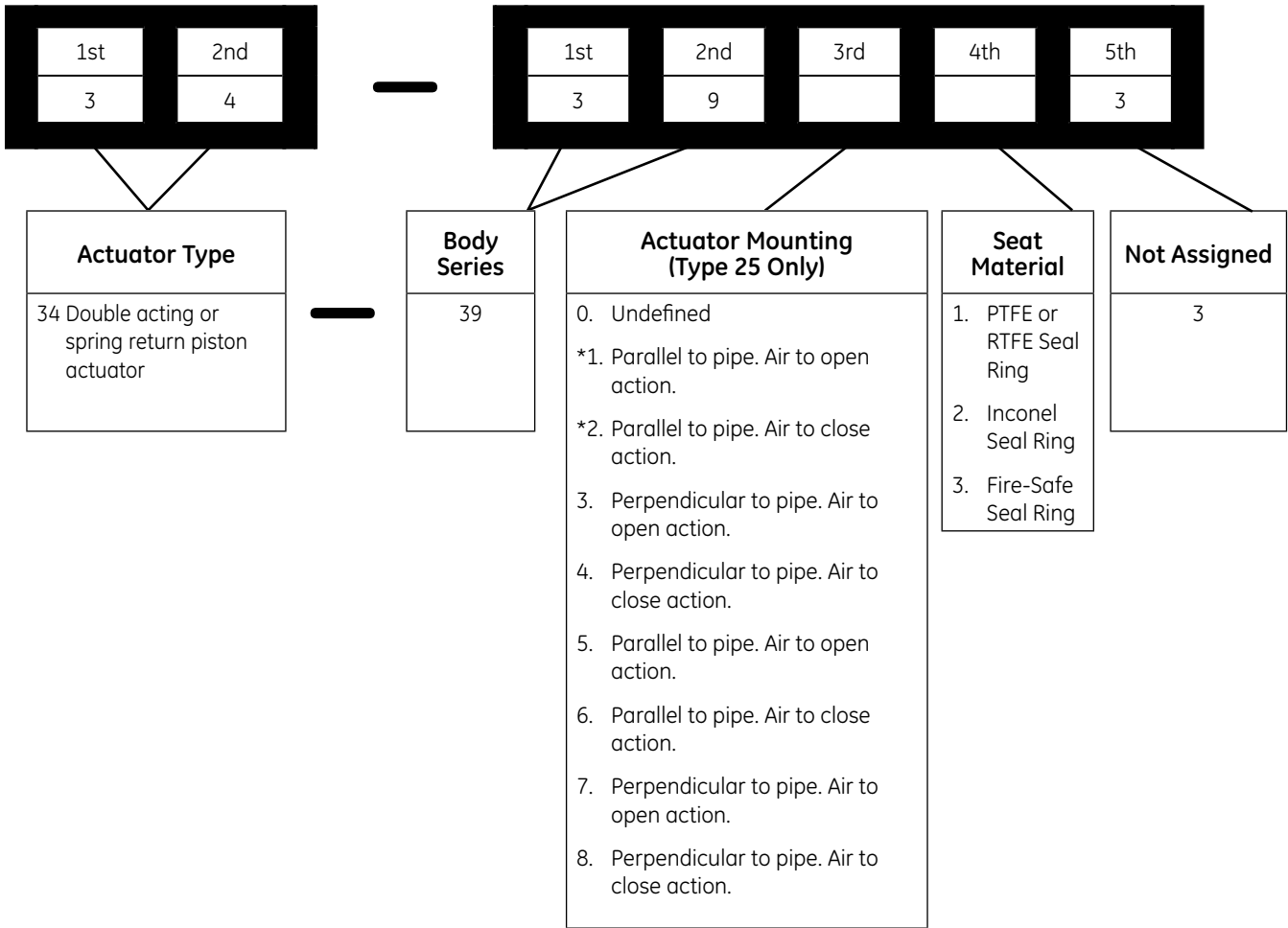

Figure 2

Numbering System



*Standard Actuator Mounting Arrangement

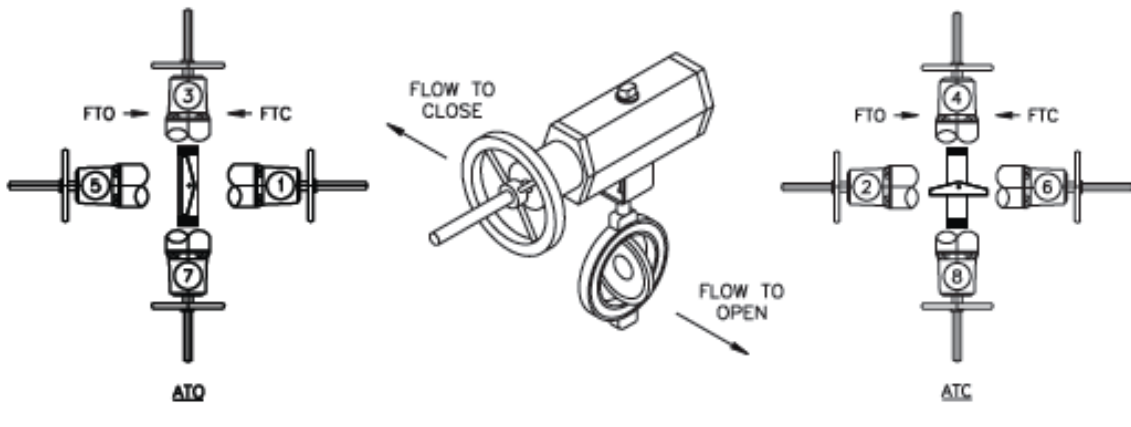

Figure 3

General Data

Flow Characteristic: equal percentage
 Flow Direction: bi-directional
 Seal Leakage: per ANSI FCI 70-2 Class VI,
 PTFE, RTFE
 Class IV, metal seals
 C_v Ratio: 100:1

Valve Sizes		ANSI Class		
inches	mm	150 Carbon & St. St.	300 Carbon & St. St.	600 ⁽¹⁾ Carbon & St. St.
2	50	•	•	•
3	80	•	•	•
4	100	•	•	•
6	150	•	•	•
8	200	•	•	•
10	250	•	•	•
12	300	•	•	•
14	350	•	•	•
16	400	•	•	•
18	450	•	•	
20	500	•	•	
24	600	•	•	
30	750	•	•	
36	900	•		
42	1050	•		
48	1200	•		

1. ANSI Class 600 rating available in soft seat constructions only. Consult GE for fire-safe or metal seat requirements.

Pressure/Temperature Ratings

Soft and Fire-Safe Seal

As temperature increases, the pressure retaining capability of materials decreases. The graph below illustrates the pressure/temperature ratings for ANSI Class 150, Class 300 and Class 600.

The heavy lines define the ratings of the carbon steel and stainless steel valve body (or "shell") in conformance to ANSI B16.34. The shaded areas define the ratings of the PTFE and RTFE Seal materials (Soft Seal).

Seal ratings are based on differential pressure with the disc in the fully closed position.*

Steam Service (Soft Seal only)

PTFE sealed valves are rated for 50 psi saturated steam.

Valves with "O" seal configuration (RTFE seal/AFLAS O-ring) are rated to 100 psi steam service.

ANSI B16.34 Body and Flowseal Soft Seal Pressure - Temperature Ratings

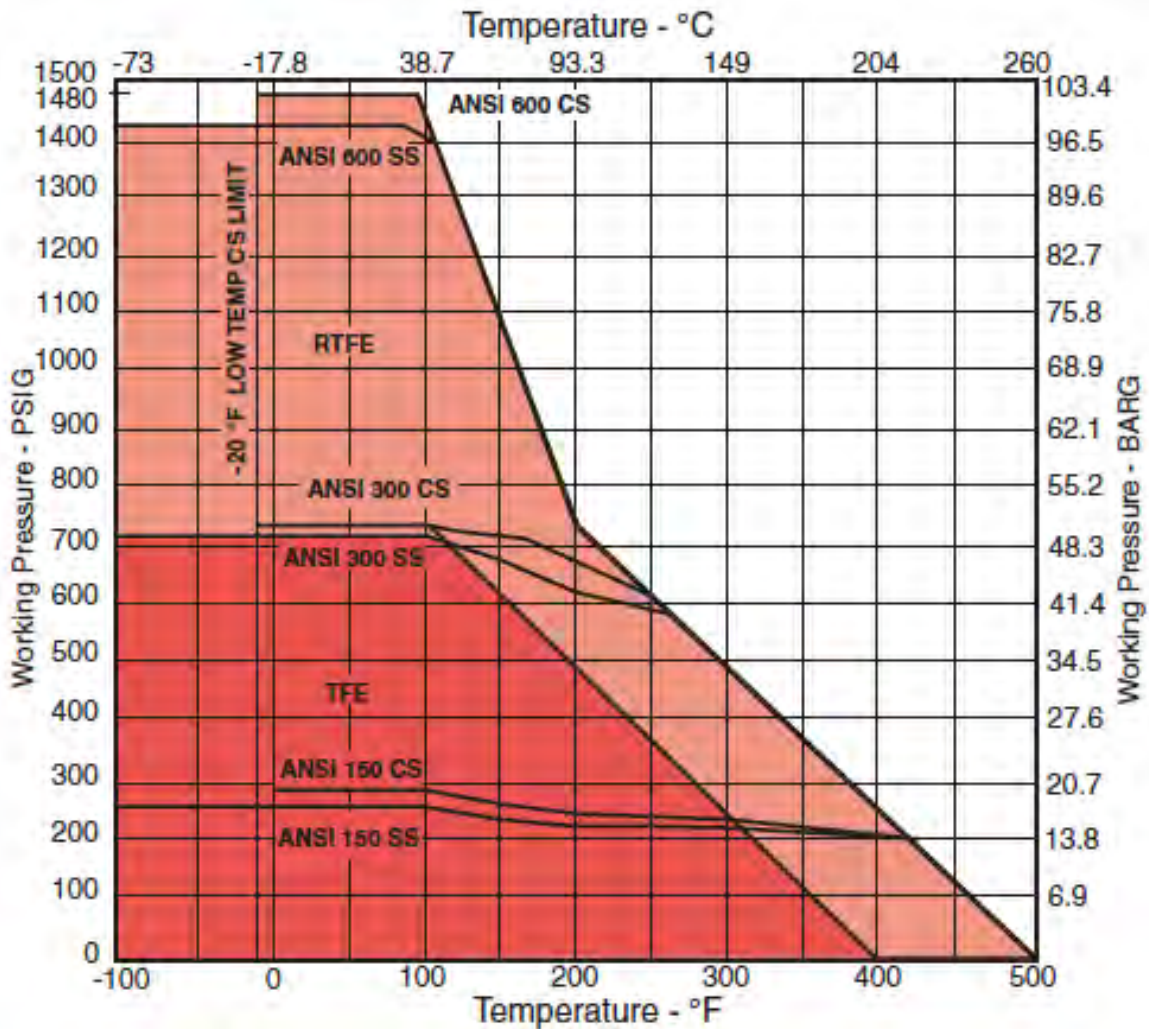

* Valves with 316SS shafts are rated for maximum pressure differentials of 150 psi for Class 150, 300 psi for Class 300, and 600 psi for Class 600.

Pressure/Temperature Ratings

Metal Seal

As temperature increases, the pressure retaining capability of materials decreases. The graph below illustrates the pressure/temperature ratings for ANSI Class 150, Class 300 and Class 600.

The heavy lines define the ratings of the carbon steel and stainless steel valve body (or "shell") in conformance to ANSI B16.34. The shaded areas define the ratings of the metal seal.

Seal ratings are based on differential pressure with the disc in the fully closed position.*

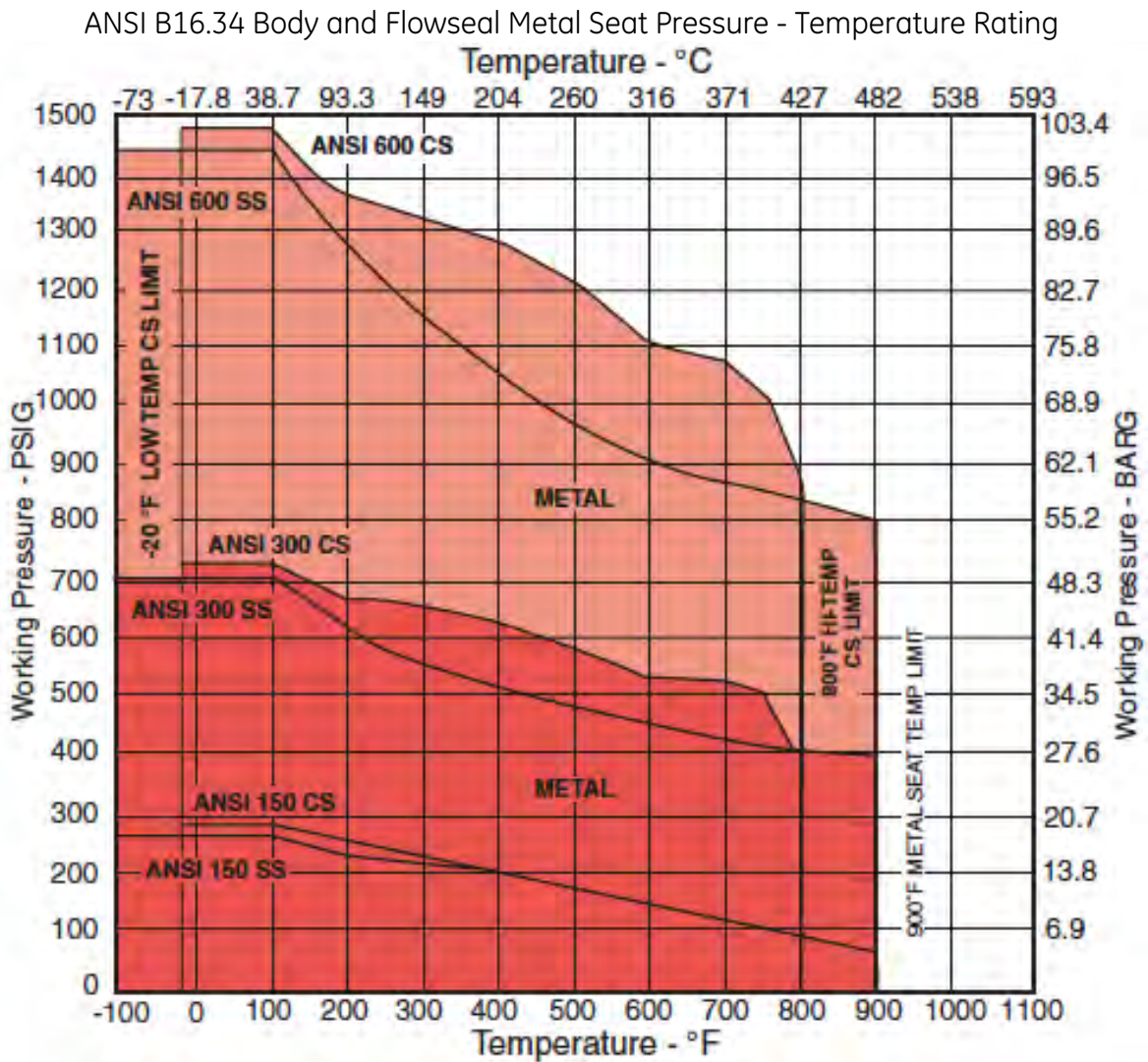

* Valves with 316SS shafts are rated for maximum pressure differentials of 150 psi for Class 150, 300 psi for Class 300, and 600 psi for Class 600.

Body Assembly Data

Body

Type:

wafer or lug with integral bonnet

Sizes:

2", 3", 4", 6", 8", 10", 12", 14", 16", 18", 20", 24", 30", 36", 42",
48" (50 mm-1200 mm)

Materials:

carbon steel
ASTM A216 Gr WCB or ASTM A105
stainless steel
ASTM A351 Gr CF8M or ASTM A182-F316

Connections:

flangeless
clamped between ANSI Class 150, 300 or 600 line flanges
single flanged
bolts between ANSI Class 150, 300 or 600 line flanges

Ratings:

ANSI Class 150
carbon steel and stainless steel 2" - 48" sizes (50 mm-
1200 mm)
ANSI Class 300
carbon steel and stainless steel 2" - 30" sizes (50 mm-
750 mm)
ANSI Class 600
carbon steel and stainless steel 2" - 16" sizes (50 mm-
400 mm)

Seal:

PTFE, RTFE or Inconel with 304 stainless steel O-Ring

Disc

Type:

offset eccentric disc

Materials:

stainless steel ASTM A351 Gr CF8M or ASTM A182-F316
Nitrided

Shaft

Type:

Keyed on outboard end

Materials:

17-4 PH stainless steel A564 Gr 630 (others optional)

Valve Bearings:

PTFE-lined fiberglass
bronze (up to 750° F)
stainless steel (above 750° F)

Packing Box:

bolted
Packing
PTFE V-ring
graphite (optional)

Actuator Data

(Model 33) – Sizes 3” – 8” (80mm – 200mm)

Type: spring-diaphragm, floating stem pneumatic actuator

Action: increasing air extends stem

Bench Range: B size 7-16 psig (48-110 kPa) size 9-16 psig (62-110 kPa)

Connection: 1/4” NPT

Fail Safe Action: field reversible

Yoke: carbon steel

Bracket: cast iron

Handwheel: (optional) push type tilting, rising stem, permanently lubricated materials: 17-4 PH and AISI 416 stainless steel adjustable limit stops

Bracket Bearing: a sealed, permanently lubricated ball bearing

(Model 34) – Sizes 3” – 48” (80mm – 1200mm)

Type: Spring-return, or double-acting scotch yoke piston

Body: Extruded aluminum, anodized finish sizes 210 to 280 & 88
Ductile Iron sizes 90 and 100

Seals: Buna-N

Pressure rating: 150 psi (1034 kPa) maximum working pressure

Manual Override: Declutchable direct mount sizes 210 to 280
Hydraulic size 88
Bevel Gear sizes 90 and 100

Optional Construction: Low temperature or high temperature seals, low pressure hydraulic.

Actuator Size	Valve Size		Effective Area		Travel	
	in.	mm.	sq. in.	sq. cm	in.	mm
B	3	80	70	452	2.625	66.5
	4	100	70	452	2.625	66.5
C	6	150	140	903	2.625	66.5
	8	200	140	903	2.625	66.5
	optional					
	3	80	140	903	2.625	66.5
	4	100	140	903	2.625	66.5

Rated Flow Coefficients (C_v) and Pressure Recovery Coefficients (F_L)

Rated Flow Coefficients (C_v)

The values shown are for the valve installed in the seal upstream ("SUS") position.

Valve Size	ANSI Class	Degree Open/% Full C_v								
		10°	20°	30°	40°	50°	60°	70°	80°	90°
		1.5%	6%	14%	25.2%	38%	55%	75%	97%	100%
2	150	1.5	6	14	25	39	56	76	99	102
	300	1.4	6	13	24	36	52	71	95	100
	600	1.4	5	13	23	35	51	70	90	93
3	150	3.4	14	32	57	87	125	141	221	228
	300	3.2	13	30	53	81	117	159	212	223
	600	3.1	12	29	52	79	114	156	202	208
4	150	6.8	27	63	114	171	248	338	437	451
	300	6.2	25	58	104	157	228	310	414	435
	600	5.8	23	54	98	147	213	290	375	387
6	150	15.5	66	154	278	419	607	827	1070	1103
	300	14.9	60	139	250	377	546	744	992	1041
	600	14.7	59	137	247	372	538	734	950	979
8	150	30.9	124	289	520	784	1135	1584	2002	1064
	300	27.3	109	255	459	692	1001	1365	1820	1911
	600	26.8	107	250	451	679	983	1341	1734	1788
10	150	52.8	211	492	886	1336	1934	2638	3411	3817
	300	45.6	183	26	767	1156	1673	2282	3042	3194
	600	41.2	165	384	692	1044	1511	2060	2665	2747
12	150	72.6	290	677	1219	1838	2660	3628	4690	4837
	300	63.3	253	590	1063	1602	2319	3163	4217	4428
	600	58.4	233	545	981	1479	2140	2918	3774	3891
14	150	90	392	914	1646	2481	3592	4898	6530	6857
	300	81	326	760	1368	2063	2986	4072	4530	5702
	600	73	292	682	1228	1838	2680	3655	4727	4873
16	150	132	531	1230	2229	3361	4865	6634	8845	9287
	300	109	435	1015	1827	2755	3988	5438	7850	8243
	600	96	385	899	1619	2423	3533	4818	6231	6424
18	150	171	684	1596	3873	4332	6270	8550	11270	11400
	300	139	555	1295	2331	3515	5088	6938	9250	9712
20	150	207	828	1932	3478	3244	7590	10350	13800	14420
	300	158	630	1470	2646	3990	5775	7875	10150	10658
24	150	315	1260	2940	5292	7890	11550	15750	21000	22050
	300	242	966	2254	4057	6118	8855	12075	16100	16205
30	150	491	1965	4585	8253	12445	18012	24563	32750	34388
	300	404	1614	3769	6779	10222	14795	20175	26900	28245
36	150	707	2830	6602	1184	17920	25938	35370	45745	47160
42	150	963	3851	8987	16176	24392	35304	48143	62264	64190
48	150	1258	5030	11738	21128	31859	46111	62881	81324	83840

Pressure Recovery Coefficients (F_L)

	Disc Degree Opening															
	15°	20°	25°	30°	35°	40°	45°	50°	55°	60°	65°	70°	75°	80°	85°	90°
Seal Upstream	.95	.91	.84	.81	.78	.80	.77	.74	.74	.73	.70	.66	.63	.60	.57	.53
Seal Downstream	.94	.89	.84	.82	.80	.77	.75	.72	.69	.66	.63	.30	.58	.55	.54	.53

Standard Valve Components

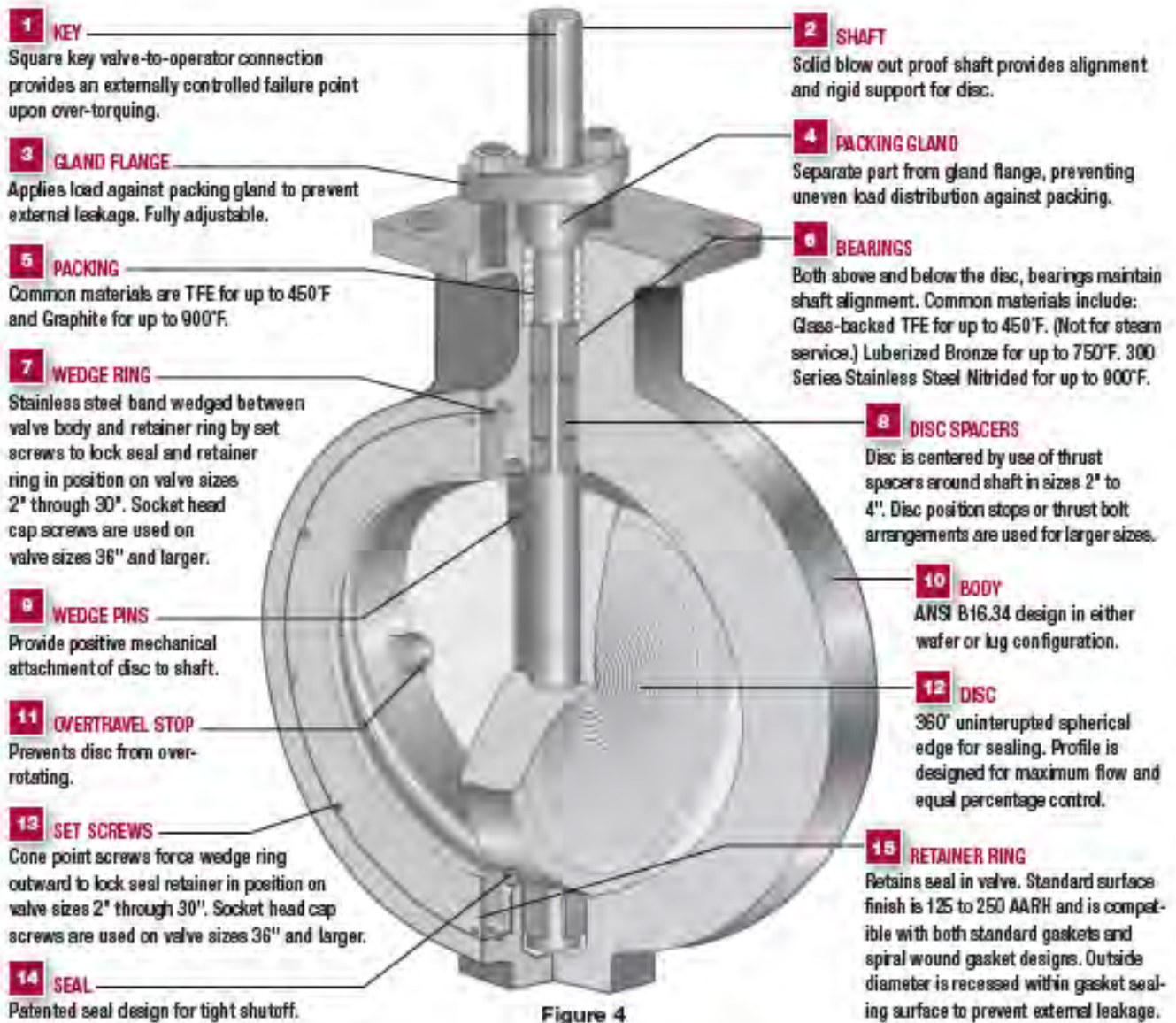
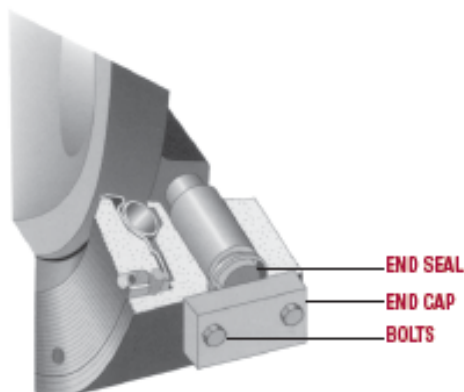

Figure 4

End Seal Variation

The ANSI 150 14" through 24" sizes feature a two-piece shaft design. The lower shaft utilizes an end seal in the body to prevent external leakage. The component parts include an end seal, an end cap and end cap bolts.



Lower Packing Variation

The ANSI 150 30" through 48"; ANSI 300 14" through 30"; ANSI 600 10" through 16" sizes feature a two-piece shaft design which utilizes a lower packing seal in the valve body to prevent external leakage. The component parts are of the same design used in the packing assembly in the top of the valve body neck.

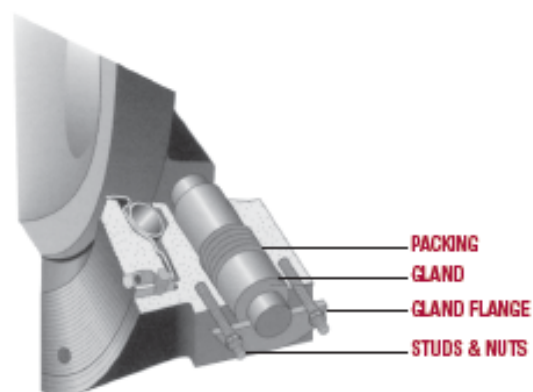

Standard Materials of Construction

Metal Seal Design

Carbon Steel Construction

Item Number	Description	-20°F to +450°F (-29°C to +232°C)	+451°F to +750°F (+233°C to +399°C)	+751°F to +800°F (+400°C to +427°C)
2	Shaft	17-4 PH Stainless Steel ASTM A564 Gr 630		
5	Packing	PTFE	Graphite	
6	Bearings	Glass-Backed PTFE	Bronze	316 Stainless Steel Nitrided
10	Body	Carbon Steel A216 Gr WCB or A105		
12	Disc	316 Stainless Steel A351 CF8M or A182 F316 Nitrided		
14	Seal	Inconel		

Stainless Steel Construction

Item Number	Description	-100°F to +450°F (-73°C to +232°C)	+451°F to +750°F (+233°C to +399°C)	+751°F to +900°F (+400°C to +482°C)
2	Shaft	17-4 PH Stainless Steel ASTM A564 Gr 630	316 Stainless* Steel ASTM A479 Gr 316	
5	Packing	PTFE	Graphite	
6	Bearings	Glass-Backed PTFE	Bronze	316 Stainless Steel Nitrided
10	Body	316 Stainless Steel A351 CF8M or A182 F316		
12	Disc	316 Stainless Steel A351 CF8M or A182 F316 Nitride		
14	Seal	Inconel		

* Metal seal valves with 316 SS shafts have reduced pressure differential ratings. Monel, Nitronic 50 and Inconel (718 or X750) may be substituted for higher differential pressures and elevated temperatures. Please consult GE for application assistance.

Standard Materials of Construction

Soft Seal Design

Item Number	Description	-100°F to +400°F (-73°C to +204°C)	+400°F to +500°F (+204°C to +260°C)
2	Shaft	17-4 PH Stainless Steel ASTM A564 Gr 630	
		Optional: 316 SS, Inconel 718/750, Monel, Alloy 20, Nitronic 50, Hastelloy C, and Others	
5	Packing	TFE	
		Optional: Graphite	
6	Bearings	Glass-Backed PTFE	
		Optional: 316 SS Backed TFE, Hastelloy C Backed TFE	
10	Body	Carbon Steel A216 Gr WCB or A105	
		Optional: 316 SS ASTM A351 CF8M or A182 F316, Monel, Alloy 20, Aluminum Bronze, or Hastelloy C	
12	Disc	316 Stainless Steel A351 CF8M or A182 F316	
		Optional: Monel, Alloy 20, Aluminum Bronze, or Hastelloy C	
14	Seal	PTFE	
		Optional: RTFE, Polyethylene (UHMWPE)	

Fire-Safe Design

Item Number	Description	-100°F to +400°F (-73°C to +204°C)	+400°F to +500°F (+204°C to +260°C)
2	Shaft	17-4 PH Stainless Steel ASTM A564 Gr 630	
		Optional: 316 Stainless Steel	
5	Packing	Fire-Safe	
6	Bearings	Fire-Safe (Garfil & 316 SS)	
10	Body	Carbon Steel A216 Gr WCB or A105	
		Optional: 316 SS ASTM A351 CF8M or A182 F316, Monel, Alloy 20, or Hastelloy C, and Others	
12	Disc	316 Stainless Steel A351 CF8M or A182 F316 - ENP	
		Consult Factory for Optional Materials	
14	Seal	Fire-Safe (TFE & Inconel)	RTFE & Inconel
		Optional: TFE & Monel, TFE & Hastelloy C	RTFE & Monel, RTFE & Hastelloy C

Allowable Pressure Drops

GE has created a simple actuator sizing and selection program, which allows for quick and accurate actuator sizing based on the specific service conditions. This program is designed to run in Microsoft® Excel®, and is available from your local GE sales representative.

The opening screen of the sizing program is shown below. Operating variables can be selected from a number of pull-down menus. The program will then provide an actuator

recommendation, along with calculations for the required torque (with safety margins) for valve seating, unseating, and throttling conditions.

This program covers standard product construction only. Please consult with your local GE sales representative, or with the factory, for applications and conditions not covered by this program.

39003 HPBV Actuator Quick Selector	
I. Specification Inputs	II. Actuator Selection Output
ANSI Pressure Class	300 Class
Size (Inches)	4"
Flow Direction	Flow-to-Open
Air Action	Air-to-Close
Seat Construction	Soft Seat
Air Supply (Psig)	25 Psig
Shaft Material	17-4 PH
Service Sizing Factor	Normal
Shutoff Delta P (Psig)	600 Psig
Throttling Delta P (Psig)	150 Psig
Throttling Position (Deg)	50 Deg
	Actuator Model
	33-C
	Seating/Unseating Torque (in-lbs)
	790
	Throttling Torque (in-lbs)
	1,250
	<u>Notes</u>
	Shaft Material Acceptable
	Select SEVERE Service Sizing Factor for Soft Seat applications < 40 °F

Weights (lbs.)

150 Class Assemblies

Actuator Type Valve Size	Valve Type	Brack- Wt et WT	RC210		RC220		RC230		RC240		RC250		RC260		RC270		RC280		RC88		RCI90		RCG100		33 Actuator										
			DA	SR	DA	SR	DA	SR	DA	SR	DA	SR	DA	SR	DA	SR	DA	SR	DA	SR	DA	SR	DA	SR	DA	SR	Yoke Wt	DA	DA						
			3.1	4	4	5.85	8	10.4	10.6	15.5	20.4	26.8	27	40	69	69	89	142	162	330	618	772	684	1102			32	85							
2	WAFER	8	12	23.1	24	24	25.85	28	30.4	30.4	35.5															24	64	117							
	LUG	11	12	26.1	27	2	28.85	31	33.4	33.4	38.5															24	67	120							
3	WAFER	11	12	26.1	27	27	28.85	31	33.4	33.4	38.5															24	67	120							
	LUG	13	12	28.1	29	29	30.85	33	35.4	35.6	40.5															24	69	122							
4	WAFER	17	12	32.1	33	33	34.85	37	39.4	39.6	44.5															24	73	126							
	LUG	25	2	40.1	41	41	42.85	45	47.4	47.6	52.5															24	81	134							
6	WAFER	30	12					50	52.4	52.6	57.5	62.4	68.8	69	82											24		139							
	LUG	35	12					55	57.4	57.6	62.5	67.4	73.8	74	87											24		144							
8	WAFER	44	12							72.5	76.4	82.8	83	96	125	125											24		153						
	LUG	48	12							75.5	80.4	86.8	87	100	129	129											24		157						
10	WAFER	71	14								105.4	111.8	112	125	154	154	174	227																	
	LUG	191	14								125.4	131.8	132	145	174	174	194	247																	
12	WAFER	110	14									157	170	199	199	219	272																		
	LUG	127	14									174	187	216	216	236	289																		
14	WAFER	135	16										182	195	224	224	244	297																	
	LUG	183	16										230	243	272	272	292	345																	
16	WAFER	182	20											271	271	291	344	364	532																
	LUG	250	20											339	339	359	412	432	600																
18	WAFER	234	20												323	323	343	396	416	584	872	1026	938												
	LUG	305	20												394	394	414	467	487	655	943	1097	1009												
20	WAFER	320	20													429	482	502	670	958	1112	1024													
	LUG	414	20													523	576	596	764	1052	1206	1118													
24	WAFER	505	25														692	860	1148	1302	1214	1632													
	LUG	702	25														889	1057	1345	1499	1411	1829													
30	WAFER	925	25															1112	1280	1568	1722	1634	2052												
	LUG	1130	25															1317	1485	1773	1927	1839	2257												
36	WAFER	1630	25																1985	2273	2427	2339	2757												
	LUG	1890	25																2245	2533	2687	2599	3017												
42	WAFER	2475	25																	2830	3118	3272	3184	3602											
	LUG	2700	25																	3055	3343	3497	3409	3827											
48	WAFER	2815	25																		3170	3458	3612	3524	3942										
	LUG	3085	25																		3440	3728	3882	3794	4212										

NOTES: 1. The weights of actuators are without handwheel
 2. DA = Double Acting / SR = Spring Return

Handwheel Weights

Actuator Type												
RC210 DA/SR	RC220 DA/SR	RC230 DA/SR	RC240 DA/SR	RC250 DA/SR	RC260 DA/SR	RC270 DA/SR	RC280 DA/SR	RC88 DA/SR	RC90 & 100 DA	RC90 & 100 SR	33 Actuator	
1.5	1.5	2.5	2.5	6.5	6.5	26	26	250	185	66	22	

Weights (lbs)

300 Class Assemblies

Actuator Valve Size	Type	Valve Wt	Bracket WT	RC210		RC220		RC230		RC240		RC250		RC260		RC270		RC280		RC88		RCI90		RCG100		33 Actuator										
				DA	SR	DA	SR	DA	SR	DA	SR	DA	SR	DA	SR	DA	SR	DA	SR	DA	SR	DA	SR	DA	SR	DA	SR	Yoke Wt	DA	DA						
				3.1	4	4	5.85	8	10.4	10.6	15.5	20.4	26.8	27	40	69	69	89	142	162	330	618	772	684	1102				32	85						
2	WAFER	8	12	23.1	24	24	25.85	28	30.4	30.6	35.5															24	64	117								
	LUG	11	12	26.1	27	27	28.85	31	33.4	33.6	38.5															24	67	120								
3	WAFER	11	12	27.1	28	28	29.85	32	34.4	34.6	39.5															24	68	121								
	LUG	13	12	32.1	33	33	34.85	37	39.4	39.6	44.5															24	73	126								
4	WAFER	17	12			33	34.85	37	39.4	39.6	44.5															24	73	126								
	LUG	25	2			40	41.85	44	46.4	46.6	51.5															24	80	133								
6	WAFER	30	12					50	52.4	52.6	57.5	62.4	68.8	69	82											24		139								
	LUG	35	12					69	71.4	71.4	76.5	81.4	87.8	88	101											24		158								
8	WAFER	44	12							79.5	84.4	90.8	91	104	133	133											24		161							
	LUG	48	12							107.5	112.4	118.8	119	132	161	161											24		189							
10	WAFER	71	14									122.4	128.8	129	142	171	171	191	244																	
	LUG	191	14									149.4	155.8	156	169	198	198	218	271																	
12	WAFER	110	14											194	207	236	236	256	309																	
	LUG	127	14											240	253	282	282	302	355																	
14	WAFER	135	16													328	341	370	370	390	443	463	631													
	LUG	183	16													367	380	409	409	429	482	502	370													
16	WAFER	182	20															425	425	445	498	518	686	974	1128	1040	1458									
	LUG	250	20															490	490	510	563	583	751	1039	1193	1105	1523									
18	WAFER	234	20																	482	482	502	555	575	743	1031	1185	1097	1515							
	LUG	305	20																	606	606	626	679	699	867	1155	1309	1221	1639							
20	WAFER	320	20																			619	672	692	860	1148	1302	1214	1632							
	LUG	414	20																			844	897	917	1085	1373	1527	1439	1857							
24	WAFER	505	25																					847	900	920	1088	1376	1530	1442	1860					
	LUG	702	25																					1134	1187	1207	1375	1663	1817	1729	2147					
30	WAFER	925	25																							1932	2100	2388	2542	2454	2872					
	LUG	1130	25																							2332	2500	2788	2942	2854	3272					

600 Class Assemblies

Actuator Valve Size	Type	Valve Wt	Bracket WT	RC210		RC220		RC230		RC240		RC250		RC260		RC270		RC280		RC88		RCI90		RCG100		33 Actuator				
				DA	SR	DA	SR	DA	SR	DA	SR	DA	SR	DA	SR	DA	SR	DA	SR	DA	SR	DA	SR	DA	SR	DA	SR	Yoke Wt	DA	DA
				3.1	4	4	5.85	8	10.4	10.6	15.5	20.4	26.8	27	40	69	69	89	142	162	330	618	772	684	1102				32	85
2	WAFER	8	12	26.1	27	27	28.85	31	33.4	33.6	38.5															24	67	120		
	LUG	11	12	28.1	29	29	30.85	33	35.4	35.6	40.5															24	69	122		
3	WAFER	11	12	28.1	29	29	30.85	33	35.4	35.6	40.5															24	69	122		
	LUG	13	12	33.1	34	34	35.85	38	40.4	40.6	45.5															24	74	127		
4	WAFER	17	12			46	47.85	50	52.4	52.6	57.5															24	86	139		
	LUG	25	2			68	69.85	72	74.4	74.6	79.5															24	108	161		
6	WAFER	30	12					62	64.4	64.6	69.5	74.4	80.8	81	94											24		151		
	LUG	35	12					105	107.4	107.6	112.5	117.4	123.8	1224	137											24		194		
8	WAFER	44	12							99.5	104.4	110.8	111	124	153	153											24		181	
	LUG	48	12							154.5	159.4	165.8	166	197	208	208											24		236	
10	WAFER	71	14									204.4	210.8	211	224	253	253	273	326	346	514	802	956	868	1286					
	LUG	191	14									267.4	273.8	274	274	316	315	336	389	409	577	865	1019	931	1349					
12	WAFER	110	14											286	299	328	328	348	401	421	589	877	1031	943	1361					
	LUG	127	14											420	433	462	462	482	535	555	723	1011	1165	1077	1495					
16	WAFER	182	20													1255	1255	1275	1328	1348	1516	1804	1958	1870	2288					
	LUG	250	20													1255	1255	1275	1328	1348	1516	1804	1958	1870	2288					

NOTES: 1. The weights of actuators are without handwheel
 2. DA = Double Acting / SR = Spring Return

Dimensions

Model 34 (RC) Actuators - Dimensional Dat

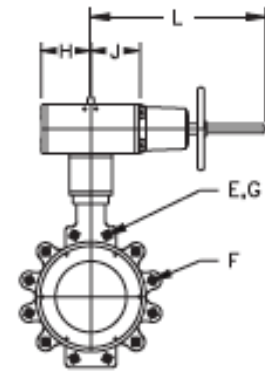
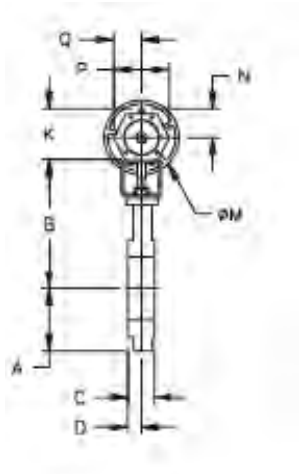

Double Acting
Sizes 210 thru 280

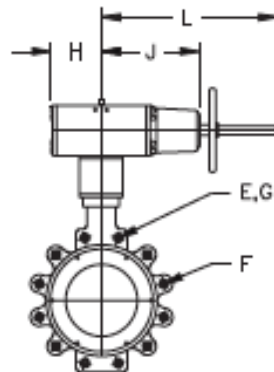

Spring Return
Sizes 210/230/250/270

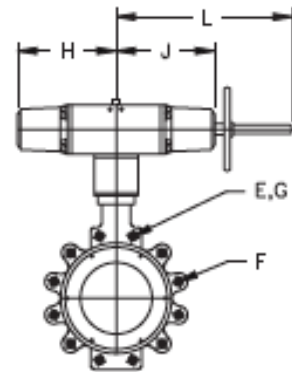

Spring Return
Sizes 220/240/260/280

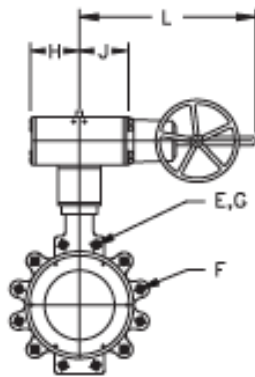
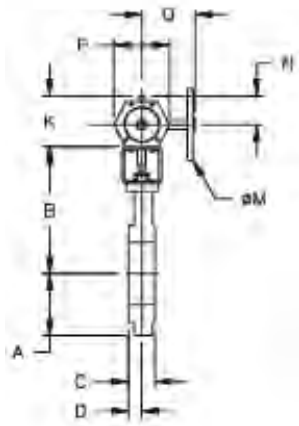

Double Acting
Size 100

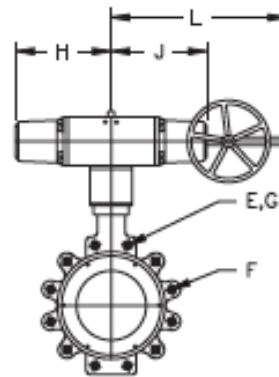

Spring Return
Sizes 100

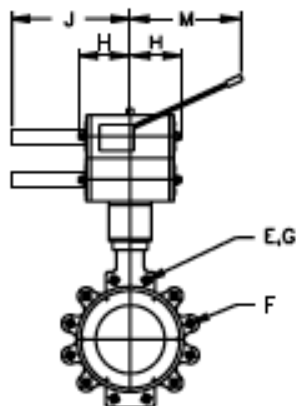
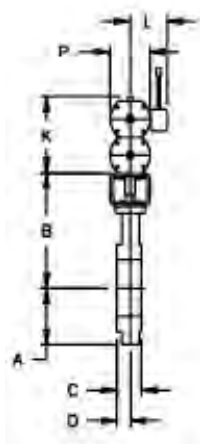

Double Acting
Size 88

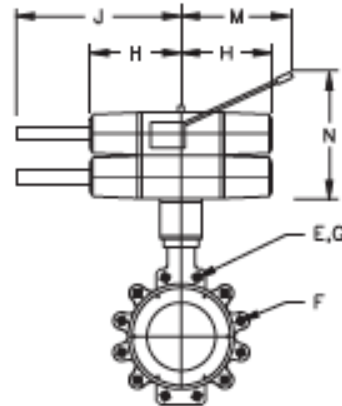

Spring Return
Sizes 88

Dimensions

Model 33 Actuator - Dimensional Data

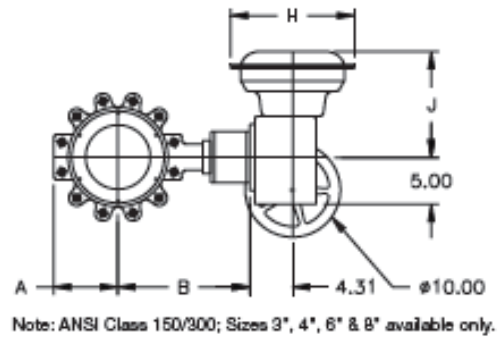
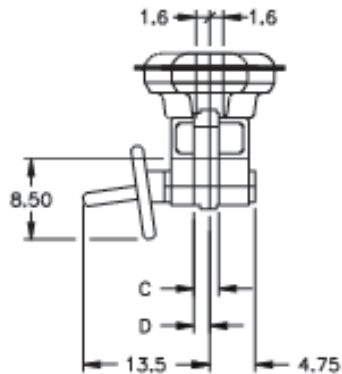

Model 39003 Butterfly Valve Table									
	Valve Size	Wafer A*	Lug A**	B	C	D	Thread Size E	# of Holes F	Bolt Circle G**
	ANSI Class 150	2	3.00	3.00	10.25	1.75	1.06	5/8-11	4
3		3.00	3.38	11.00	1.92	1.20	5/8-11	4	6.00
4		3.50	4.13	11.75	2.13	1.26	5/8-11	8	7.50
6		4.88	5.12	13.00	2.31	1.38	5/8-11	8	9.50
8		5.88	6.01	14.13	2.50	1.49	5/8-11	8	11.75
10		6.88	7.88	14.88	2.81	1.70	3/4-10	12	14.25
12		9.50	9.50	16.63	3.23	1.86	3/4-10	12	17.00
14		11.07	11.07	17.25	3.62	2.19	7/8-9	12	18.75
16		12.05	12.05	22.69	4.00	2.31	7/8-9	16	21.25
18		13.18	13.18	24.00	4.50	2.45	1-8	16	22.75
20		13.94	13.94	25.13	5.00	2.94	1-8	20	25.00
24		16.44	16.44	27.25	6.06	3.12	11/8-8	20	29.50
30		22.73	22.73	3.62	6.75	3.53	11/8-8	28	36.00
36		32.11	32.11	38.50	8.38	4.34	11/4-8	32	42.75
42	35.62	35.62	44.00	9.25	5.03	11/4-8	36	49.50	
48	38.25	38.25	47.25	10.62	5.62	11/4-8	44	56.00	
ANSI Class 300	2	3.00	3.00	10.25	1.75	1.06	5/8-11	8	5.00
	3	3.00	3.38	11.00	1.92	1.20	3/4-10	8	6.63
	4	3.50	4.12	11.75	2.13	1.25	3/4-10	8	7.88
	6	5.12	5.50	13.00	2.29	1.38	3/4-10	12	10.63
	8	5.88	7.28	14.14	2.88	1.54	7/8-9	12	13.00
	10	7.38	7.88	15.38	3.25	1.70	1-8	16	15.25
	12	10.50	10.50	21.00	3.62	1.86	11/8-8	16	17.75
	14	14.57	14.57	22.38	4.62	2.48	11/8-8	20	20.25
	16	16.32	16.32	24.00	5.25	2.59	11/4-8	20	22.50
	18	17.26	17.26	25.13	5.88	3.03	11/4-8	24	24.75
20	18.49	18.49	26.39	6.31	3.24	11/4-8	24	27.00	
24	21.67	21.67	29.38	7.19	3.62	11/2-8	24	32.00	
30	30.50	30.50	38.88	8.88	4.39	13/4-8	28	39.25	
ANSI Class 600	3	3.00	3.00	11.00	2.12	1.20	3/4-10	8	6.63
	4	4.62	4.62	12.00	2.50	1.40	7/8-9	8	8.50
	6	5.56	6.75	13.62	3.06	1.66	1-8	12	11.50
	8	7.38	8.03	15.13	4.00	1.85	11/8-8	12	13.75
	10	13.25	13.25	19.00	4.62	2.00	11/4-8	16	17.00
	12	14.67	14.67	22.63	5.50	2.53	11/4-8	20	19.25
16	-	18.87	30.00	7.00	3.50	11/2-8	20	23.75	

Model 34 (RC) Actuator Table									
	Size	H	J	K	L	M	N	P	Q
	Spring Return	RC210	1.8	5.7	3.7	11.4	7.1	2.3	2.9
RC220		5.7	5.7	3.7	11.4	7.1	2.3	2.9	1.3
RC230		2.6	7.7	5.0	13.4	7.9	2.9	4.1	1.9
RC240		7.7	7.7	5.0	13.4	7.9	2.9	4.1	1.9
RC250		3.5	11.2	6.9	19.7	12.6	3.8	5.7	2.7
RC260		11.2	11.2	6.9	19.7	12.6	3.8	5.7	2.7
RC270		5.7	20.1	10.9	31.5	15.7	6.1	8.7	4.3
RC280		20.5	20.5	10.9	31.5	15.7	6.1	8.7	4.3
RC88		20.5	37.9	19.5	9.1	19.5	39.8	8.7	4.3
RC100		33.5	33.5	19.0	58.0	31.5	10.7	13.8	6.9
Double Acting	RC210	1.8	3.9	3.7	11.4	7.1	2.3	2.9	1.3
	RC220	3.9	3.9	3.7	11.4	7.1	2.3	2.9	1.3
	RC230	2.6	5.3	5.0	13.4	7.9	2.9	4.1	1.9
	RC240	5.3	5.3	5.0	13.4	7.9	2.9	4.1	1.9
	RC250	3.5	7.5	6.9	19.7	12.6	3.8	5.7	2.7
	RC260	7.5	7.5	6.9	19.7	12.6	3.8	5.7	2.7
	RC270	5.7	11.8	10.9	31.5	15.7	6.1	8.7	4.3
	RC280	12.2	12.2	10.9	31.5	23.6	6.1	8.7	4.3
	RC88	12.2	29.6	19.5	9.1	19.5	39.8	8.7	4.6
	RC100	20.5	20.5	19.0	58.0	31.5	10.7	13.8	6.9

Model 33 Actuator Table									
	Size	H	J	K	L	M	N	P	Q
	CL 150	3	13.00	11.50	-	-	-	-	-
4		13.00	11.50	-	-	-	-	-	-
6		17.50	15.20	-	-	-	-	-	-
8		17.50	15.20	-	-	-	-	-	-
CL 300	3	13.00	11.50	-	-	-	-	-	-
	4	13.00	11.50	-	-	-	-	-	-
	6	17.50	15.20	-	-	-	-	-	-
	8	17.50	15.20	-	-	-	-	-	-

* - Dimensions apply to wafer valves only
 ** - Dimensions apply to lugged valves only

Notes

Notes

DIRECT SALES OFFICE LOCATIONS

BELGIUM

Phone: +32-2-344-0970
Fax: +32-2-344-1123

BRAZIL

Phone: +55-11-2146-3600
Fax: +55-11-2146-3610

CHINA

Phone: +86-10-5689-3600
Fax: +86-10-5689-3800

FRANCE

Courbevoie

Phone: +33-1-4904-9000
Fax: +33-1-4904-9010

GERMANY

Ratingen

Phone: +49-2102-108-0
Fax: +49-2102-108-111

INDIA

Mumbai

Phone: +91-22-8354790
Fax: +91-22-8354791

New Delhi

Phone: +91-11-2-6164175
Fax: +91-11-5-1659635

ITALY

Phone: +39-081-7892-111
Fax: +39-081-7892-208

JAPAN Chiba

Phone: +81-43-297-9222
Fax: +81-43-299-1115

KOREA

Phone: +82-2-2274-0748
Fax: +82-2-2274-0794

MALAYSIA

Phone: +60-3-2161-0322
Fax: +60-3-2163-6312

MEXICO

Phone: +52-55-3640-5060

THE NETHERLANDS

Phone: +0031-15-3808666
Fax: +0031-18-1641438

RUSSIA

Veliky Novgorod

Phone: +7-8162-55-7898
Fax: +7-8162-55-7921

Moscow

Phone: +7 495-585-1276
Fax: +7 495-585-1279

SAUDI ARABIA

Phone: +966-3-341-0278
Fax: +966-3-341-7624

SINGAPORE

Phone: +65-6861-6100
Fax: +65-6861-7172

SOUTH AFRICA

Phone: +27-11-452-1550
Fax: +27-11-452-6542

SOUTH and CENTRAL

AMERICA and the CARIBBEAN

Phone: +55-12-2134-1201
Fax: +55-12-2134-1238

SPAIN

Phone: +34-93-652-6430
Fax: +34-93-652-6444

UNITED ARAB EMIRATES

Phone: +971-4-8991-777
Fax: +971-4-8991-778

UNITED KINGDOM

Wooburn Green

Phone: +44-1628-536300
Fax: +44-1628-536319

UNITED STATES

Massachusetts

Phone: +1-508-586-4600
Fax: +1-508-427-8971

Corpus Christi, Texas

Phone: +1-361-881-8182
Fax: +1-361-881-8246

Deer Park, Texas

Phone: +1-281-884-1000
Fax: +1-281-884-1010

Houston, Texas

Phone: +1-281-671-1640
Fax: +1-281-671-1735



* Trademark of General Electric Company
Other company names and product names used in this document are the registered trademarks
or trademarks of their respective owners.

© 2014 General Electric Company. All rights reserved.

GEA20238A 07/2014