

Gear Products

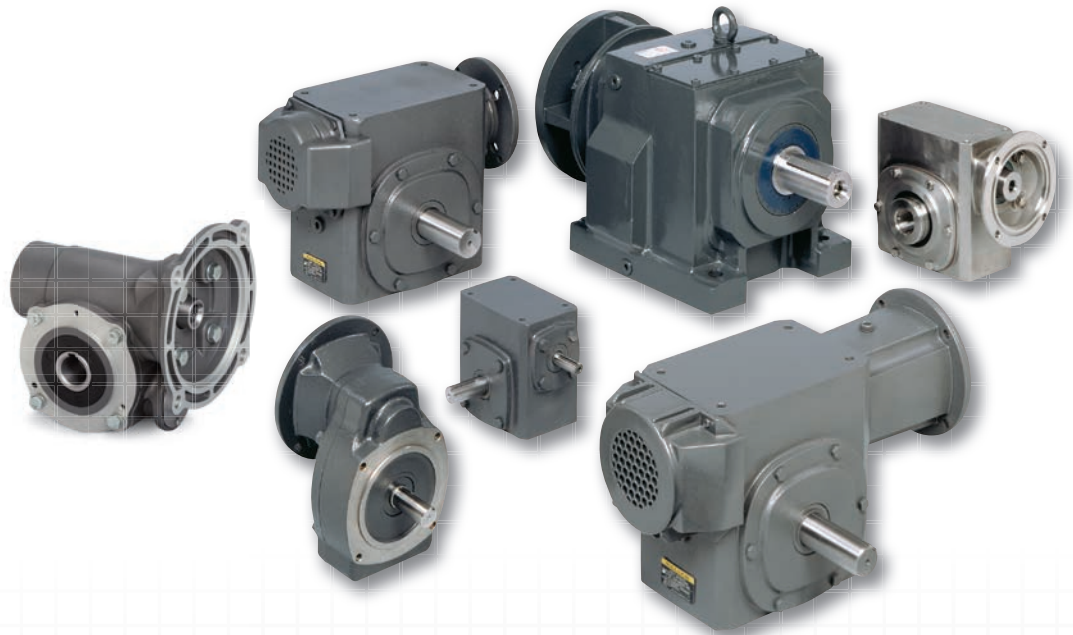

BALDOR
A MEMBER OF THE ABB GROUP

Why Baldor?

For almost 100 years, Baldor has strived to provide customers with the best value and reliability in industrial products. To be considered by customers as the best...

Baldor products are available at more locations than any other brand.

Our 35 North America warehouse distribution centers offer immediate availability at any time to Baldor's distributors.

Industry's Shortest Lead Times



Baldor has the industry's shortest lead times on custom products. Our unique Flex-Flow™ manufacturing process allows us to produce any order, in any quantity, quickly and efficiently.

Broad Line of Stock Products

Save valuable time with just one call to Baldor. We offer over 6,000 different stock gear products, electric motors and adjustable frequency drives.

Commitment to Inventory

Baldor's distribution centers and regional warehouses stock over \$75 million of inventory ready to ship 24 hours a day.



Best Information

Only Baldor offers customers such a wide choice of sources for product information. Use our printed catalogs and brochures, or visit our website at www.baldor.com. Or talk to one of our customer service persons at any Baldor sales office.

Over 5000 Possible Gear Reducer Variations

Single Reduction Worm Gear Reducers



Double Reduction Worm Gear Reducers

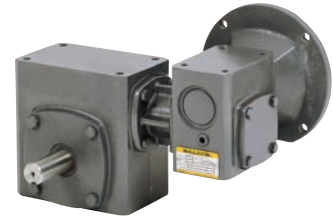

Washdown Worm Gear Reducers



In-Line Helical Gear Units



Ratio Multipliers



Table of Contents

H50 Hollow Shaft-Worm Gear Reducer	3
900 Series Features and Benefits	5
900 Series Single Reduction	7 - 50
900 Series Double Reduction	53 - 77
Accessories	78 - 83
Ratio Multiplier	84 - 89
Baldor In-Line Helical (ILH)	90 - 146
Universal Series Single Reduction	147 - 162
Universal Series Double Reduction	163 - 175
Engineering Section	176 - 188
Parts Identification	189 - 197
Seal and Coupling Kits	198 - 199
Conversion Tables	200 - 201
Warranty	202
District Offices	Back Cover

H50
Reducer

900 Series
Single Reduction

900 Series
Double Reduction

Accessories

Ratio Multiplier

In-Line Helical (ILH)

Universal Series
Single Reduction

Universal Series
Double Reduction

Engineering

900 Series Single Reduction

H50 Reducer
900 Series Single Reduction
900 Series Double Reduction
Accessories
Ratio Multipliers
In-Line Helical (LH)
Universal Series Single Reduction
Universal Series Double Reduction
Engineering

900 Series Features and Benefits	5
Style Reference Guide	6 - 7
How to Order	8
Selection Process	9
Quick Selection Guide	10
Ratings Tables	11 - 13
Stock Speed Reducers	14 - 24
Dimensions	25 - 51
Bearing Carrier Dimensions	52



H50 Reducer Features and Benefits

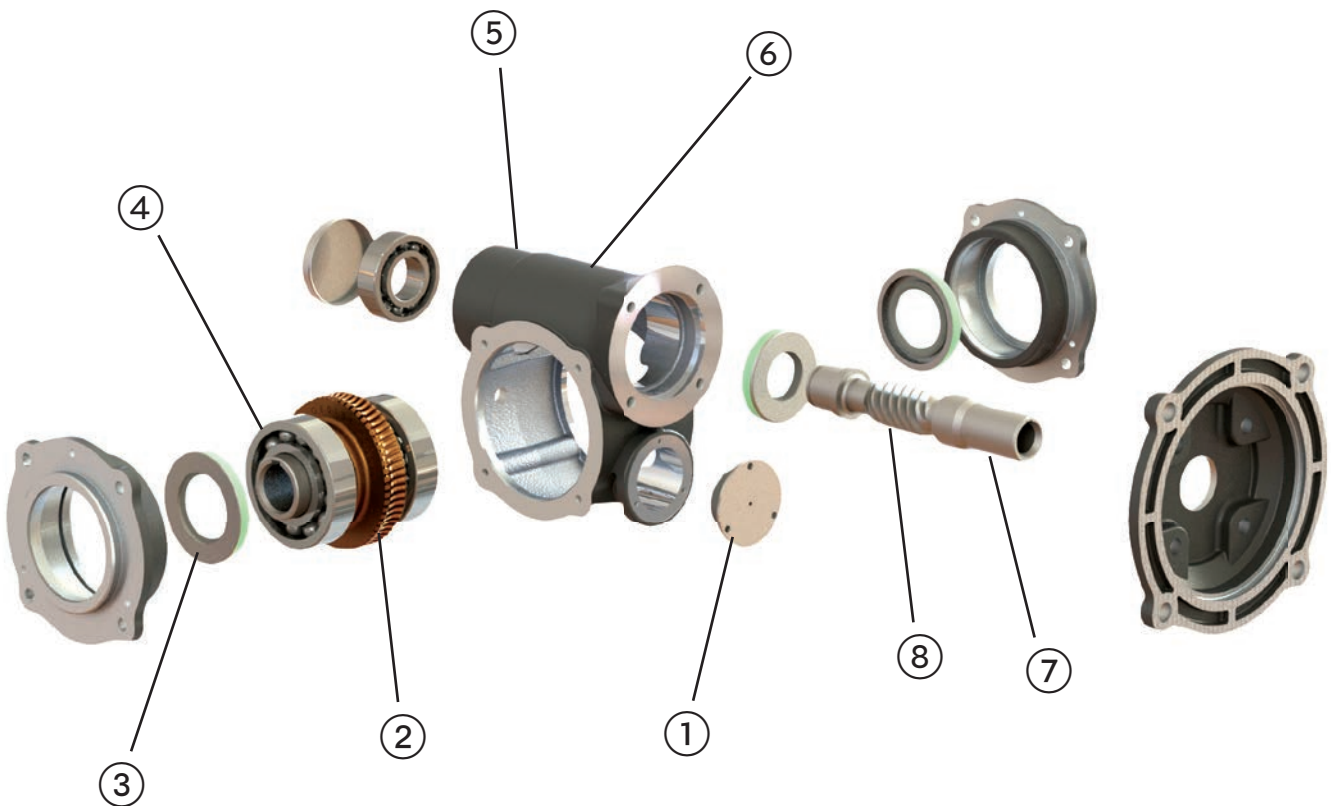

1. Internal expansion bladder removes the possibility of oil contamination and allows multi-position mounting.
2. Chill cast bronze gear provided superior wear characteristics and long life. Gear is keyed to output shaft for positive, reliable torque transmission.
3. Spring loaded seals provide positive oil retention.
4. Oversized, heavy duty bearings allow greater load capacity and extended service life.

5. Rugged die cast aluminum construction provides excellent thermal dissipation.
6. Synthetic oil lubrication for maximum efficiency and long maintenance free operation.
7. Plunge ground seal journals provide positive sealing and extended leak free operation.
8. Induction hardened and precision ground worm significantly increases service life, load capacity, and efficiency while reducing noise.



H50 - Right Angle Hollow Shaft - Worm Gear Reducer

Applications: Conveyors, material handling equipment, packaging machinery, medical and laboratory equipment, printing presses, commercial ovens, and machine tools.

Features: Ball bearing on output for smooth torque transmission. High strength bronze gearing with hardend and ground worm for quiet operation and increased radial load capacity. High performance low friction, bidirectional motor seals. Permanently lubricated with synthetic oil. Internal oil expansion bladder allows for multi-position mounting without the need to relocate breather vents.

Nominal Output RPM @ 1750 RPM In	Gear Ratio	Continuous Duty Output Torque (In-Lbs) Based on 1750 RPM Motor						Max Input Hp	Max Output Torque Rating In-Lbs	Style Number	Catalog Number	Mult. Sym.	Ap'x Shpg. Wgt.	
		0.25	0.33	0.50	0.75	1.00	1.50							2.00
350	5:1					156	235	315	2.57	435	HF-H-05-H100	GHH0556	GB	11
175	10:1				230	300	450		1.88	600	HF-H-10-H100	GHH1056	GB	11
117	15:1			176	263	350			1.37	483	HF-H-15-H100	GHH1556	GB	11
88	20:1			275	394	550			1	550	HF-H-20-H100	GHH2056	GB	11
70	25:1			240	350	529			.83	583	HF-H-25-H101	GHH2556	GB	11
58	30:1			247	350	550			.76	562	HF-H-30-H100	GHH3056	GB	11
44	40:1	268	345	528					.64	672	HF-H-40-H100	GHH4056	GB	11
35	50:1	310	400	609					.56	685	HF-H-50-H100	GHH5056	GB	11
29	60:1	300	418	600					.5	600	HF-H-60-H100	GHH6056	GB	11

- Note:**
- Service Class I Torque Ratings (1.0 Service Factor)
 - Service Class II Torque Ratings (≥ 1.4 Service Factor)
 - Service Class III Torque Ratings (≥ 2.0 Service Factor)

Vertical motor below gearhead not recommended.
 Avoiding those positions where the high speed oil seal is immersed in oil will provide greater security against high speed input seal wear.
 Replacement oil – 1 Qt P/N MJ0006A05SP (Klubersynth UH1-6-460)

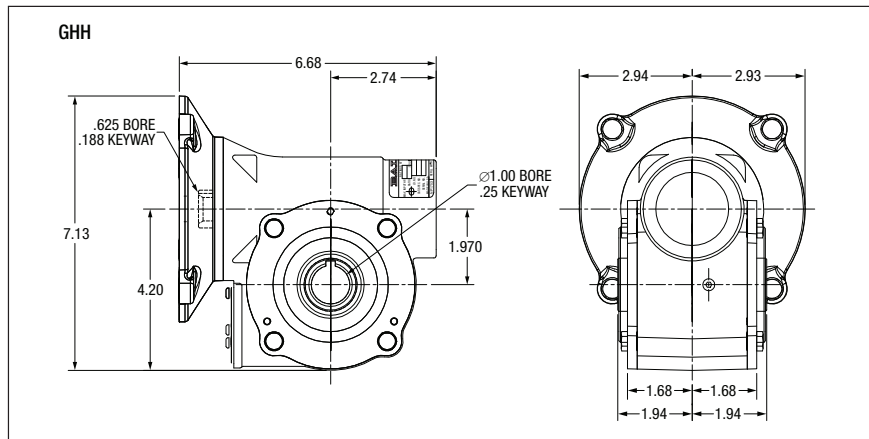

Gearbox Accessories



Applications: Baldor offers optional base and shaft kits for H style gearmotors. Adding a base and shaft kit allows them to be used in applications requiring a rightangle shaft extension. The shaft can be used for either right or left hand output applications.

Catalog Number	Description	Mult. Sym.	Ap'x Shpg. Wgt.
B19H71	Horiz Base Kit	A8	1
SH10HS	Output Shaft Kit	A8	2
TA05HK	Torque Arm Kit	A8	2

900 Series Features and Benefits

Sealed housing. No breather vent required, preventing contamination from outside environment. All 900 Series reducers are supplied filled with oil. The end user does not have the expense of filling units at the job site. This also reduces the chance of someone forgetting to install oil and damaging the reducer by running it dry.

Cast iron construction provides a rigid housing which reduces noise and vibration. It is also resistant to caustic washdown solutions. Large oil capacity improves heat dissipation and results in cooler operation. Supplied with Klubersynth UHI-6-460 synthetic oil, which provides a wide operating temperature range. This lifetime lubrication results in reduced maintenance costs and improved efficiency. Industry standard mounting.

Oversized, heavy duty bearings allow greater thrust capacity and extended service life.

Rugged fan and guard provide optimum cooling for maximum ratings on 3.25 CD and larger units.

Plunge ground seal journals provide positive sealing and extended leak free operation.

Chill cast bronze gear provides superior wear characteristics and long life. Gear keyed to output shaft for positive, reliable torque transmission.

Worm precision ground after heat treat to reduce noise and increase efficiency.

Spring loaded seals provide positive oil retention.

Symmetrical housing design allows precise gear alignment. Easy field conversion of output shaft position. Double reduction units can be assembled from stock single reduction units with double reduction adapter kit.

All units are pressure tested for leaks prior to shipment. Any leak source is detected and corrected prior to shipment.

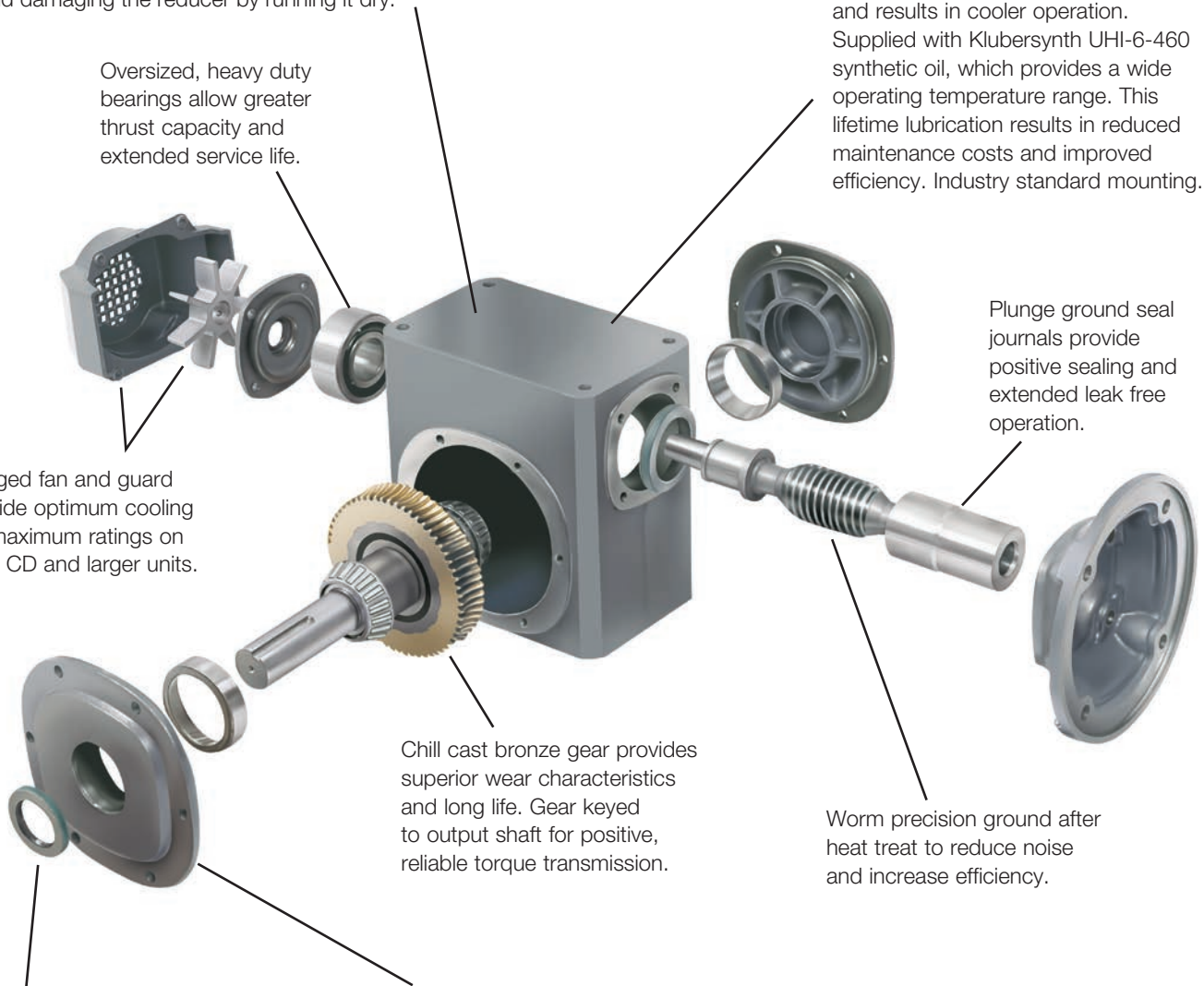

H50
Reducer

900 Series
Single Reduction

900 Series
Double Reduction

Accessories

Ratio Multiplier

In-Line Helical (LH)

Universal Series
Single Reduction

Universal Series
Double Reduction

Engineering

STOCK STYLES

Baldor products are available at more locations than any other brand. Our 35 District Offices across North America and offices around the world, offer immediate availability.

900 Series Style Reference Guide

MODIFIED STOCK STYLES

THESE UNITS CAN BE ASSEMBLED ON A MAKE-TO-ORDER BASIS, OR STOCK STYLES CAN BE FIELD MODIFIED USING STOCK BASE AND ACCESSORY KITS.

HORIZONTAL BASE

VERTICAL BASE

F900

Flanged Quill Type Input
Standard Shaft

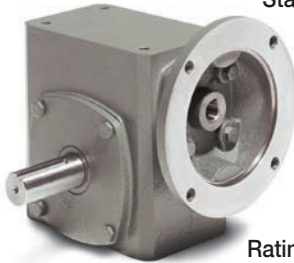

Ratings P. 11-13
Dimensions P. 25

F900B



Ratings P. 11-13
Dimensions P. 29

F900E/F



Ratings P. 11-13
Dimensions P. 30

S900

Solid Worm Type
(Projecting Input Shaft)

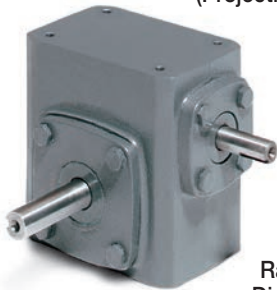

Ratings P. 11-13
Dimensions P. 34

S900B

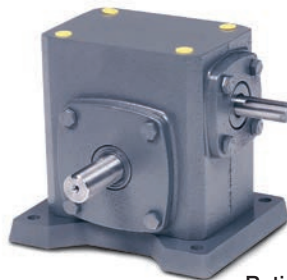

Ratings P. 11-13
Dimensions P. 35

S900E/F

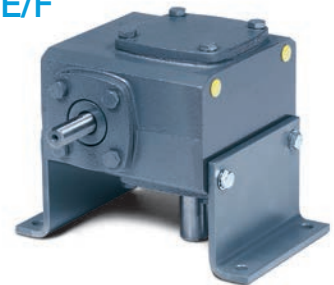

Ratings P. 11-13
Dimensions P. 37

LF900

Flanged Coupling Type Input

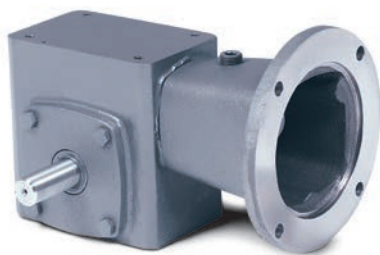

Ratings P. 11-13
Dimensions P. 40

LF900B

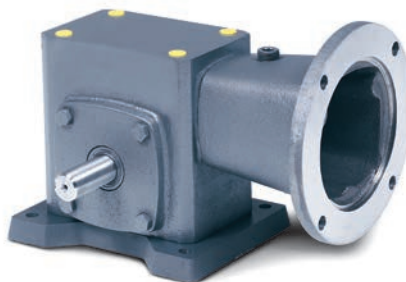

Ratings P. 11-13
Dimensions P. 41

LF900E/F



Ratings P. 11-13
Dimensions P. 42

HF900

Flanged Quill Type Input
Hollow Output



Ratings P. 11-13
Dimensions P. 45

HF900B



Ratings P. 11-13
Dimensions P. 46

HF900E/F



Ratings P. 11-13
Dimensions P. 47

HFO
Reducer

900 Series
Single Reduction

900 Series
Double Reduction

Accessories

Ratio Multipliers

In-Line Helical (LH)

Universal Series
Single Reduction

Universal Series
Double Reduction

Engineering

900 Series Style Reference Guide

MODIFIED STOCK STYLES (continued)

J MOUNT

OUTPUT FLANGE

F900X



Ratings P. 11-13
Dimensions P. 31

F900R/L



Ratings P. 11-13
Dimensions P. 32

F900BRB



Ratings P. 11-13
Dimensions P. 33

S900X



Ratings P. 11-13
Dimensions P. 38

S900R/L



Ratings P. 11-13
Dimensions P. 39

Bases and Accessories



P. 79-83

LF900X



Ratings P. 11-13
Dimensions P. 43

LF900R/L

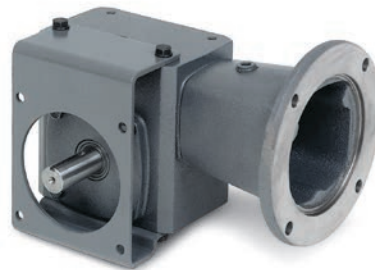

Ratings P. 11-13
Dimensions P. 44

Hollow Bore Bushing Kits



P. 83

HF900X



Ratings P. 11-13
Dimensions P. 48

HF900R/L



Ratings P. 11-13
Dimensions P. 49

HF900TA



Ratings P. 11-13
Dimensions P. 50

HF900V/W *

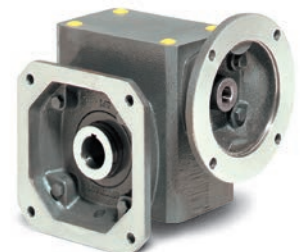

Ratings P. 11-13
Dimensions P. 51

* CANNOT BE FIELD MODIFIED.

Single Reduction 900 Series Numbering System/How to Order

H50 Reducer
900 Series Single Reduction
900 Series Double Reduction
Accessories
Ratio Multipliers
In-Line Helical (LH)
Universal Series Single Reduction
Universal Series Double Reduction
Engineering

F - 924 - B - 30 - B5 - G 107

WASHDOWN OPTIONS
Blank = Standard Finish
SS = Stainless Steel *
WD = Washdown

* Available in 918, 921, 926 and 932

OUTPUT SHAFT
Blank = Standard Shaft
H = Hollow Bore

STYLE
Solid Output Shaft
F = Flanged Quill type input
S = Solid worm type (projecting input shaft)
LF = Flanged coupling type input

SIZE (Center Distance)	
913	1.33
915	1.54
918	1.75
921/921G	2.06
924	2.38
926	2.62
930	3.00
932	3.25
938	3.75

BASE/ASSEMBLY
A = Horizontal base, worm under gear
B = Horizontal base, worm over gear
C = Vertical base, High
D = Vertical base, Low
E = Vertical base, High
F = Vertical base, Low
R/L = Steel output flange
V/W = Cast iron output flange
X = Vertical base, J mount
BRB = Horizontal base with riser block

RATIO
5:1 THROUGH 60:1
(see ratio and capacity selection tables for available ratios, p. 9-11.)

NEMA INPUT BORE CODES		
Bore Code	Input Bore	NEMA Mtg.
B5	.625	56C
B7	.875	140TC/180C
B9	1.125	180TC.210C
B11	1.375	210TC/250UC

OUTPUT SHAFT ASSEMBLY
G = Left hand
H = Double shaft
J = Right hand

FRACTION SIZE	OUTPUT BORE CODE	SIZE								DECIMAL SIZE	
		913	918	921	924	926	930	932	938		
1/2	008	O								0.500	
5/8	010	S	O							0.625	
3/4	012	O	O							0.750	
1	100		S	O						1.000	
1-1/8	102			O	O					1.125	
1-3/16	103			O	O	O				1.188	
1-1/4	104			S	O	O	O	O		1.250	
1-3/8	106			O	O	O				1.375	
1-7/16	107			O	S	S	O	O	O	1.438	
1-1/2	108					O	O	O		1.500	
1-15/16	115					O	S	S		1.938	
2-1/8	202						O	O	O	2.125	
2-3/16	203							O	O	S	2.188
Max Bore		0.750	1.125	1.625	1.688	2.000	2.188	2.188	2.188		
Keyway		0.188	0.250	0.375	.0375	0.500	0.500	0.500	0.500		

S = Standard Bore O = Optional Bore

HOW TO ORDER

Please specify Style, Size, Base (if required), Ratio, NEMA Input Flange (if flanged reducer), Output shaft assembly.

EXAMPLE

Required size: Quill type input, 924, 30:1 ratio, 56C input flange, left hand output (facing input flange) with a horizontal base (worm over gear).

- Reducer and base assembly
Order Reducer **F-924-B-30-B5-G**
- Reducer with base ship separately
Order Reducer **F-924-30-B5-G (GF3024AG)** See stock ratings on page 14.
Base **B24H71**. See page 81.

SEE PAGE 183 FOR MOUNTING POSITION CHOICES.

How to Use the Ratio and Capacity Selection Tables

REQUIRED INFORMATION: To select the proper reducer for a given application, several important factors should be taken into consideration. They are: Application, Horsepower, Torque, Ratio and Overhung Load.

Note: See Engineering Information page 185 for detailed information and calculations on horsepower, torque, ratio and overhung load.

The ratio and capacity tables are on pages 11-13. Use these tables or 900 Series Stock Reducer tables on pages 12-22 to select the appropriate reducer.

Example:
A reducer is needed for a uniform load operation 24 hours per day. It will be driven by a 1 HP, 1750 RPM, 56C frame motor. The output speed required is 350.

1 Determine **Service Factor** from Table 1; multiply the HP (or torque required) by the **Service Factor** (uniform load 24 hours per day = 1.25) 1 HP x 1.25 = 1.25 design HP

TABLE 1
SERVICE FACTORS

Prime Mover	Duration of Service Total Operating Time Per Day	Driven Machine Load Classification		
		Uniform	Moderate Shock	Heavy Shock
Electric Motor	Occasional 1/2 Hour	0.80	0.90	1.00
	Intermittent 2 Hours	0.90	1.00	1.25
	10 Hours	1.00	1.25	1.50
	24 Hours	1.25	1.50	1.75

*See pages 11-13 for complete service factor table.

BALDOR
900 SERIES SINGLE REDUCTION RATIO & CAPACITY SELECTION TABLES
HORSEPOWER & TORQUE RATINGS FOR SERVICE CLASS I (1.0 Service Factor)

RATIO	INPUT RPM	OUTPUT RPM	SIZE 913			SIZE 915			SIZE 918		
			INPUT HP	OUTPUT HP	OUTPUT TORQUE IN. LBS.	INPUT HP	OUTPUT HP	OUTPUT TORQUE IN. LBS.	INPUT HP	OUTPUT HP	OUTPUT TORQUE IN. LBS.
5	2400	480	1.29	1.08	142	1.68	1.50	197	2.25	2.05	259
	1750	350	1.11	0.92	165	1.50	1.28	231	2.00	1.78	320
	1150	230	0.88	0.69	189	1.20	0.99	270	1.62	1.39	380
	850	174	0.69	0.55	202	0.96	0.80	290	1.31	1.14	414
7.5	2400	220	0.10	0.08	237	0.15	0.11	316	0.21	0.16	505
	1750	162	0.08	0.06	270	0.11	0.08	366	0.16	0.12	566
	1150	110	0.06	0.04	303	0.08	0.06	414	0.12	0.09	622
	850	82	0.04	0.03	336	0.06	0.04	464	0.09	0.07	683
10	2400	240	0.90	0.62	225	1.03	0.81	290	1.50	1.19	428
	1750	175	0.68	0.47	255	0.80	0.60	331	1.16	0.88	488
	1150	125	0.53	0.35	280	0.63	0.48	353	1.02	0.70	520
	850	100	0.08	0.05	303	0.10	0.07	336	0.14	0.10	586
12.5	2400	120	—	—	—	1.00	—	—	—	—	—
	1750	88	—	—	—	0.87	—	—	—	—	—
	1150	65	—	—	—	0.65	—	—	—	—	—
	850	48	—	—	—	0.52	—	—	—	—	—
15	2400	96	0.54	0.30	195	0.60	0.42	279	0.91	0.58	378
	1750	70	0.50	0.26	238	0.51	0.35	318	0.80	0.49	444
	1150	46	0.38	0.18	251	0.41	0.26	358	0.65	0.38	520
	850	35	0.30	0.15	265	0.34	0.21	380	0.54	0.31	561
20	2400	72	0.40	0.22	162	0.44	0.29	227	0.67	0.42	306
	1750	54	0.33	0.18	189	0.36	0.24	270	0.54	0.34	366
	1150	38	0.24	0.12	202	0.27	0.17	290	0.41	0.25	414
	850	28	0.18	0.09	216	0.20	0.13	316	0.31	0.19	464
25	2400	58	0.32	0.19	144	0.38	0.26	197	0.54	0.35	259
	1750	43	0.26	0.15	171	0.30	0.20	231	0.41	0.26	320
	1150	30	0.19	0.10	189	0.22	0.14	270	0.31	0.19	380
	850	22	0.14	0.07	202	0.17	0.11	290	0.23	0.14	414
30	2400	48	0.26	0.15	120	0.32	0.22	162	0.44	0.28	216
	1750	36	0.21	0.12	147	0.25	0.17	197	0.34	0.21	259
	1150	25	0.15	0.08	165	0.18	0.12	231	0.25	0.15	320
	850	18	0.11	0.06	189	0.13	0.09	270	0.18	0.11	380
40	2400	36	0.19	0.11	90	0.24	0.16	120	0.33	0.21	162
	1750	27	0.14	0.08	117	0.18	0.12	156	0.25	0.15	216
	1150	19	0.10	0.06	135	0.13	0.09	189	0.18	0.11	259
	850	14	0.07	0.04	153	0.10	0.07	216	0.13	0.08	306
50	2400	24	0.12	0.07	60	0.16	0.10	80	0.22	0.14	108
	1750	18	0.09	0.05	81	0.12	0.08	108	0.16	0.10	144
	1150	13	0.06	0.04	99	0.09	0.06	135	0.11	0.07	180
	850	10	0.04	0.03	117	0.07	0.05	156	0.08	0.05	216
60	2400	18	0.09	0.05	45	0.12	0.08	60	0.16	0.10	81
	1750	14	0.07	0.04	60	0.09	0.06	81	0.12	0.08	108
	1150	10	0.05	0.03	72	0.07	0.05	99	0.09	0.06	135
	850	8	0.04	0.02	81	0.05	0.03	117	0.07	0.04	156
* OVERHUNG LOAD*		INPUT SHAFT 150 LBS. OUTPUT SHAFT 240 LBS.			INPUT SHAFT 175 LBS. OUTPUT SHAFT 300 LBS.			INPUT SHAFT 175 LBS. OUTPUT SHAFT 600 LBS.			
OUTPUT SHAFT THRUST LOAD		300 LBS			400 LBS			500 LBS			
MAXIMUM INPUT SPEED		4500 RPM			3600 RPM			3600 RPM			

5 If selection is based on torque instead of HP, find the **OUTPUT TORQUE** that is equal to or greater than required.

2 Under the **OUTPUT RPM** heading, find the rpm nearest the requirement.

3 Note corresponding **RATIO** from the left column.

4 In the **INPUT HP** column locate the rating that is greater than or equal to the required design HP

6 When HP (or torque rating) is located, look at the top of the section to find the reducer **SIZE**.

7 *Check **LOAD CAPACITIES**. Do not exceed overhung load rating or thrust load. Calculation for OHL can be found in the Engineering Section on page 185.

8 For this example, 915-05 would be the correct **SIZE & RATIO**. Complete the style number choosing style, base assembly (if required), NEMA input bore code (B5), and output shaft assembly. See page 6.

*Overhung Load Rating is at center of shaft extension with no thrust load

900 Series Horsepower Quick Select Guide

H50 Reducer

900 Series Single Reduction

900 Series Double Reduction

Accessories

Ratio Multipliers

In-Line Helical (LH)

Universal Series Single Reduction

Universal Series Double Reduction

Engineering

Total RPMS	Output RPMS	Input Horsepower @ 1750 RPMS, (1.00 Service Factor)											
		1/6	1/4	1/3	1/2	3/4	1	1-1/2	2	3	5	7-1/2	10
5	350	913	913	913	913	913	913	915	918	921	926	930	932
7.5	233	913	913	913	913	913	915	918	921	924	930	932	938
10	175	913	913	913	913	913	915	918	921	926	930	938	—
12.5	140	913	913	913	913	915	918	921	924	926	932	938	—
15	117	913	913	913	913	915	918	924	924	930	938	—	—
20	88	913	913	913	913	918	921	924	926	930	938	—	—
25	70	913	913	913	918	921	924	926	930	932	—	—	—
30	58	913	913	913	915	921	924	926	930	938	—	—	—
40	44	913	913	913	918	924	924	930	932	938	—	—	—
50	35	913	913	913	918	924	926	930	938	—	—	—	—
60	29	913	913	915	921	926	930	932	938	—	—	—	—

Total Ratio	Output RPMS	Input Horsepower @ 1750 RPMS, (1.25 Service Factor)											
		1/6	1/4	1/3	1/2	3/4	1	1-1/2	2	3	5	7-1/2	10
5	350	913	913	913	913	913	915	918	921	924	930	938	938
7.5	233	913	913	913	913	915	915	921	921	926	930	938	—
10	175	913	913	913	913	915	918	921	924	930	932	—	—
12.5	140	913	913	913	915	918	921	924	926	930	938	—	—
15	117	913	913	913	913	918	921	924	926	930	938	—	—
20	88	913	913	913	915	921	924	926	930	932	—	—	—
25	70	913	913	913	918	924	926	930	930	938	—	—	—
30	58	913	913	913	918	924	926	930	932	938	—	—	—
40	44	913	913	918	918	924	926	930	938	—	—	—	—
50	35	913	913	918	924	926	930	932	938	—	—	—	—
60	29	913	915	918	924	930	930	938	—	—	—	—	—

NOTE: Above charts are for reference only. Please see actual ratings pages 11-13.

900 Series Single Reduction Ratio and Capacity Selection Tables

Horsepower & Torque Ratings for Service Class I (1.0 Service Factor)

Ratio	Input RPM	Output RPM	Size 913			Size 915			Size 918		
			Input Hp	Output Hp	Output Torque In. Lbs.	Input Hp	Output Hp	Output Torque In. Lbs.	Input Hp	Output Hp	Output Torque In. Lbs.
5	2400	480	1.29	1.08	142	1.68	1.50	197	2.25	2.05	269
	1750	350	1.11	0.92	165	1.50	1.28	231	2.00	1.78	320
	1150	230	0.88	0.69	189	1.20	0.99	270	1.62	1.39	380
	850	174	0.69	0.55	202	0.96	0.80	290	1.31	1.14	414
	100	20	0.10	0.08	237	0.15	0.11	346	0.21	0.16	505
7.5	2400	320	0.94	0.82	161	1.44	1.17	230	1.88	1.60	315
	1750	233	0.77	0.70	188	1.27	1.00	270	1.65	1.36	368
	1150	153	0.59	0.52	214	1.01	0.77	317	1.27	1.04	427
	850	113	0.47	0.41	227	0.81	0.61	342	1.02	0.82	459
	100	13	0.07	0.05	255	0.13	0.08	409	0.16	0.11	544
10	2400	240	0.95	0.69	182	1.19	0.96	251	1.70	1.39	366
	1750	175	0.90	0.62	225	1.03	0.81	290	1.50	1.19	428
	1150	115	0.68	0.47	255	0.80	0.60	331	1.16	0.89	488
	850	85	0.53	0.35	260	0.63	0.48	353	1.02	0.70	520
	100	10	0.08	0.05	303	0.10	0.07	412	0.14	0.09	586
12.5	2400	192	0.80	0.64	185	1.00	0.80	262	1.23	1.09	357
	1750	140	0.67	0.55	211	0.87	0.67	300	1.07	0.93	420
	1150	92	0.49	0.42	238	0.65	0.49	339	0.85	0.72	493
	850	68	0.39	0.33	252	0.52	0.39	360	0.69	0.58	534
	100	8	0.05	0.05	290	0.08	0.05	415	0.11	0.08	641
15	2400	160	0.76	0.49	194	0.93	0.68	267	1.22	0.97	383
	1750	117	0.66	0.42	225	0.81	0.58	312	1.07	0.83	448
	1150	77	0.47	0.30	248	0.63	0.44	362	0.87	0.62	507
	850	57	0.38	0.24	270	0.52	0.35	388	0.68	0.48	531
	100	7	0.06	0.03	312	0.08	0.05	461	0.10	0.07	612
20	2400	120	0.59	0.39	203	0.71	0.53	277	1.00	0.72	379
	1750	88	0.53	0.33	239	0.62	0.44	317	0.92	0.64	461
	1150	58	0.42	0.24	266	0.47	0.33	360	0.80	0.49	530
	850	43	0.32	0.19	278	0.38	0.26	383	0.65	0.39	572
	100	5	0.05	0.03	328	0.06	0.04	442	0.10	0.05	668
25	2400	96	0.54	0.30	195	0.60	0.42	279	0.91	0.58	378
	1750	70	0.50	0.26	238	0.51	0.35	318	0.80	0.49	444
	1150	46	0.38	0.18	251	0.41	0.26	358	0.65	0.38	520
	850	35	0.30	0.15	265	0.34	0.21	380	0.54	0.31	561
	100	4	0.05	0.02	304	0.05	0.03	435	0.09	0.04	672
30	2400	80	0.47	0.27	213	0.55	0.36	280	0.78	0.49	383
	1750	58	0.42	0.23	248	0.50	0.29	318	0.72	0.43	470
	1150	38	0.35	0.17	275	0.38	0.22	358	0.66	0.33	547
	850	28	0.28	0.13	285	0.31	0.17	380	0.53	0.26	590
	100	3	0.04	0.02	338	0.04	0.02	435	0.09	0.03	700
40	2400	60	0.35	0.18	194	0.44	0.26	277	0.70	0.36	382
	1750	44	0.33	0.16	230	0.38	0.22	317	0.64	0.32	461
	1150	28	0.26	0.12	268	0.31	0.16	359	0.49	0.24	530
	850	21	0.22	0.09	278	0.24	0.13	381	0.43	0.19	570
	100	2.5	0.05	0.01	328	0.04	0.02	440	0.07	0.03	662
50	2400	48	0.38	0.16	212	0.39	0.20	267	0.54	0.28	370
	1750	35	0.33	0.13	234	0.33	0.17	303	0.49	0.24	436
	1150	23	0.26	0.09	250	0.27	0.12	341	0.42	0.18	489
	850	17	0.20	0.07	258	0.22	0.10	361	0.34	0.14	520
	100	2	0.06	0.01	290	0.03	0.01	414	0.05	0.02	611
60	2400	40	0.30	0.11	177	0.38	0.16	253	0.52	0.23	355
	1750	29	0.28	0.09	201	0.33	0.13	288	0.47	0.19	413
	1150	19	0.22	0.07	226	0.24	0.10	324	0.44	0.14	464
	850	14	0.18	0.05	240	0.20	0.08	343	0.37	0.12	560
	100	1.7	0.08	0.01	274	0.03	0.01	393	0.05	0.02	567
OVERHUNG LOAD*			INPUT SHAFT 150 LBS. OUTPUT SHAFT 240 LBS.			INPUT SHAFT 175 LBS. OUTPUT SHAFT 300 LBS.			INPUT SHAFT 175 LBS. OUTPUT SHAFT 600 LBS.		
OUTPUT SHAFT THRUST LOAD			300 LBS.			400 lbs.			500 LBS.		
MAXIMUM INPUT SPEED			4500 RPM			3600 RPM			3600 RPM		

*Overhung Load Rating is at center of shaft extension with no thrust load.

900 Series Single Reduction Ratio and Capacity Selection Tables

Horsepower & Torque Ratings for Service Class I (1.0 Service Factor)

Ratio	Input RPM	Output RPM	Size 921/921G			Size 924			Size 926		
			Input Hp	Output Hp	Output Torque In. Lbs.	Input Hp	Output Hp	Output Torque In. Lbs.	Input Hp	Output Hp	Output Torque In. Lbs.
5	2400	480	3.45	3.21	421	4.84	4.40	578	6.38	5.82	764
	1750	350	3.14	2.85	514	4.17	3.92	705	5.43	5.10	919
	1150	230	2.58	2.34	641	3.46	3.21	879	4.57	4.24	1163
	850	174	2.18	1.99	721	2.90	2.72	987	3.88	3.66	1327
	100	20	0.35	0.30	951	0.48	0.41	1299	0.67	0.57	1803
7.5	2400	320	3.00	2.70	532	3.70	3.46	681	4.85	4.54	895
	1750	233	2.70	2.37	640	3.28	3.03	820	4.30	3.99	1079
	1150	153	2.19	1.88	774	2.69	2.45	1009	3.52	3.22	1325
	850	113	1.83	1.53	853	2.25	2.02	1125	2.93	2.64	1475
	100	13	0.30	0.22	1071	0.37	0.30	1450	0.48	0.39	1891
10	2400	240	2.27	2.02	530	2.95	2.71	712	4.02	3.74	982
	1750	175	2.02	1.75	630	2.73	2.48	893	3.59	3.27	1177
	1150	115	1.63	1.38	756	2.34	2.06	1127	3.05	2.71	1485
	850	85	1.37	1.12	830	1.94	1.67	1239	2.50	2.17	1611
	100	10	0.22	0.16	1000	0.37	0.25	1550	0.47	0.32	2000
12.5	2400	192	1.82	1.64	537	2.60	2.36	775	3.42	3.13	1026
	1750	140	1.62	1.43	644	2.45	2.20	989	3.05	2.75	1239
	1150	92	1.30	1.12	770	1.98	1.74	1194	2.49	2.20	1510
	850	68	1.08	0.91	844	1.64	1.42	1316	2.08	1.81	1674
	100	8	0.18	0.13	1043	0.24	0.20	1556	0.34	0.27	2126
15	2400	160	1.53	1.43	562	2.29	2.04	802	2.87	2.58	1018
	1750	117	1.35	1.23	664	2.11	1.84	992	2.58	2.27	1225
	1150	77	1.09	0.97	794	1.78	1.50	1228	2.17	1.85	1515
	850	57	0.90	0.78	862	1.52	1.23	1365	1.80	1.50	1663
	100	7	0.14	0.11	1035	0.30	0.19	1689	0.36	0.23	2056
20	2400	120	1.19	1.11	581	1.87	1.61	844	2.38	2.05	1076
	1750	88	1.06	0.96	684	1.72	1.45	1038	2.15	1.83	1308
	1150	58	0.85	0.76	826	1.45	1.17	1271	1.85	1.49	1623
	850	43	0.70	0.61	888	1.22	0.95	1389	1.57	1.22	1790
	100	5	0.12	0.08	1065	0.26	0.14	1705	0.33	0.17	2186
25	2400	96	0.96	0.84	551	1.55	1.24	816	1.98	1.63	1068
	1750	70	0.89	0.75	675	1.37	1.11	1002	1.73	1.45	1307
	1150	46	0.73	0.59	806	1.11	0.87	1196	1.40	1.14	1561
	850	35	0.62	0.49	880	0.93	0.73	1308	1.16	0.95	1705
	100	4	0.11	0.07	1080	0.16	0.10	1609	0.20	0.13	2093
30	2400	80	0.94	0.75	588	1.41	1.14	900	1.70	1.40	1099
	1750	58	0.83	0.64	691	1.32	1.02	1111	1.54	1.21	1313
	1150	38	0.69	0.50	827	1.11	0.80	1328	1.30	0.97	1606
	850	28	0.55	0.39	877	0.95	0.64	1451	1.12	0.79	1768
	100	3	0.11	0.05	1057	0.21	0.08	1760	0.26	0.10	2120
40	2400	60	0.75	0.55	579	1.05	0.80	840	1.34	1.02	1068
	1750	44	0.66	0.47	680	0.99	0.72	1030	1.23	0.90	1296
	1150	28	0.57	0.37	822	0.86	0.56	1263	1.08	0.72	1611
	850	21	0.50	0.29	881	0.74	0.46	1381	0.97	0.60	1803
	100	2.5	0.09	0.04	1060	0.19	0.07	1697	0.25	0.09	2179
50	2400	48	0.65	0.42	555	0.88	0.63	833	1.08	0.79	1034
	1750	35	0.58	0.36	651	0.83	0.56	1014	1.00	0.69	1242
	1150	23	0.50	0.28	766	0.71	0.44	1213	0.88	0.55	1518
	850	17	0.43	0.22	828	0.62	0.36	1328	0.76	0.45	1668
	100	2	0.08	0.03	996	0.16	0.05	1596	0.20	0.07	2052
60	2400	40	0.56	0.34	540	0.75	0.51	803	0.89	0.62	977
	1750	29	0.50	0.29	634	0.69	0.44	958	0.82	0.54	1166
	1150	19	0.42	0.22	740	0.61	0.35	1158	0.74	0.44	1458
	850	14	0.34	0.18	798	0.53	0.28	1267	0.66	0.36	1614
	100	1.7	0.07	0.03	955	0.14	0.04	1534	0.18	0.05	1933
OVERHUNG LOAD*			INPUT SHAFT 220 LBS. OUTPUT SHAFT 750 LBS.			INPUT SHAFT 400 LBS. OUTPUT SHAFT 1000 LBS.			INPUT SHAFT 400 LBS. OUTPUT SHAFT 1100 LBS.		
OUTPUT SHAFT THRUST LOAD			700 LBS.			800 LBS.			900 LBS.		
MAXIMUM INPUT SPEED			3600 RPM			3600 RPM			3600 RPM		

*Overhung Load Rating is at center of shaft extension with no thrust load.

900 Series Single Reduction Ratio and Capacity Selection Tables

Horsepower & Torque Ratings for Service Class I (1.0 Service Factor)

Ratio	Input RPM	Output RPM	Size 930			Size 932 (FC)			Size 938 (FC)		
			Input Hp	Output Hp	Output Torque In. Lbs.	Input Hp	Output Hp	Output Torque In. Lbs.	Input Hp	Output Hp	Output Torque In. Lbs.
5	2400	480	8.83	8.29	1088	11.29	10.76	1413	15.91	14.92	1959
	1750	350	7.64	7.10	1279	9.76	9.23	1662	13.76	12.86	2315
	1150	230	6.41	5.94	1627	8.22	7.69	2107	11.39	10.55	2891
	850	174	5.60	5.22	1892	7.15	6.78	2457	10.16	9.49	3437
	100	20	1.00	0.88	2775	1.33	1.15	3628	1.98	1.71	5401
7.5	2400	320	7.50	6.76	1332	8.74	8.24	1623	12.59	11.60	2284
	1750	233	6.37	5.92	1600	7.58	7.07	1913	10.80	9.92	2682
	1150	153	5.39	4.94	2034	6.40	5.89	2426	9.06	8.23	3392
	850	113	4.61	4.18	2330	5.47	4.98	2775	7.94	7.13	3979
	100	13	.80	.65	3153	0.96	0.79	3824	1.44	1.24	6016
10	2400	240	6.03	5.61	1472	7.28	6.77	1779	10.12	9.41	2472
	1750	175	5.48	4.87	1755	6.36	5.85	2106	9.05	8.07	2905
	1150	115	4.65	4.00	2190	5.53	4.97	2725	7.83	6.72	3685
	850	85	4.03	3.32	2465	4.67	4.11	3050	7.03	5.80	4298
	100	10	0.70	0.52	3254	0.94	0.62	3908	1.37	1.02	6403
12.5	2400	192	5.12	4.70	1544	6.10	5.63	1849	8.99	7.87	2585
	1750	140	4.52	4.11	1850	5.36	4.89	2202	7.76	6.76	3043
	1150	92	3.76	3.35	2297	4.48	4.02	2754	6.53	5.63	3856
	850	68	3.16	2.78	2578	3.79	3.36	3110	5.70	4.85	4495
	100	8	0.54	0.43	3383	0.66	0.52	4134	1.05	0.84	6648
15	2400	160	4.64	4.04	1590	5.30	4.82	1898	7.74	6.74	2653
	1750	117	4.14	3.52	1903	4.66	4.16	2241	6.64	5.79	3118
	1150	77	3.48	2.88	2361	4.13	3.57	2918	5.87	4.84	3965
	850	57	3.00	2.39	2645	3.50	2.95	3267	5.23	4.17	4614
	100	7	0.51	0.38	3451	0.73	0.46	4158	1.05	0.75	6795
20	2400	120	3.76	3.10	1632	4.33	3.81	1999	6.25	5.17	2715
	1750	88	3.31	2.71	1955	3.85	3.33	2383	5.43	4.46	3193
	1150	58	2.72	2.23	2419	3.47	2.87	3120	4.61	3.73	4058
	850	43	2.31	1.85	2705	2.93	2.37	3480	4.08	3.22	4722
	100	5	0.43	0.28	3516	0.67	0.35	4359	0.84	0.55	6922
25	2400	96	3.14	2.51	1647	3.58	2.94	1931	5.22	4.17	2737
	1750	70	2.78	2.20	1978	3.13	2.62	2355	4.50	3.58	3222
	1150	46	2.27	1.78	2441	2.65	2.14	2936	3.81	2.99	4097
	850	35	1.89	1.51	2726	2.26	1.84	3305	3.30	2.64	4762
	100	4	0.38	0.22	3538	0.42	0.28	4344	0.75	0.44	6964
30	2400	80	2.75	2.09	1649	3.14	2.64	2078	4.58	3.48	2741
	1750	58	2.47	1.83	1978	2.81	2.28	2482	3.97	2.97	3226
	1150	38	2.09	1.47	2445	2.53	1.93	3200	3.48	2.47	4104
	850	28	1.80	1.21	2732	2.20	1.59	3577	3.10	2.12	4767
	100	3	0.32	0.17	3539	0.55	0.22	4542	0.66	0.33	6964
40	2400	60	2.09	1.55	1630	2.40	1.89	1989	3.48	2.58	2711
	1750	44	1.84	1.36	1960	2.20	1.66	2374	3.00	2.23	3192
	1150	28	1.49	1.07	2419	2.03	1.38	3110	2.53	1.80	4062
	850	21	1.31	0.90	2704	1.74	1.15	3465	2.26	1.57	4715
	100	2.5	0.25	0.14	3497	0.48	0.17	4348	0.60	0.27	6880
50	2400	48	1.84	1.20	1571	1.98	1.51	1977	3.06	1.99	2612
	1750	35	1.67	1.05	1890	1.83	1.31	2366	2.67	1.71	3076
	1150	23	1.45	0.85	2332	1.57	1.05	2885	2.43	1.43	3916
	850	17	1.27	0.70	2604	1.34	0.85	3133	2.22	1.23	4544
	100	2	0.21	0.11	3368	0.36	0.12	3782	0.55	0.21	6627
60	2400	40	1.63	0.95	1491	1.66	1.19	1882	2.71	1.57	2480
	1750	29	1.50	0.83	1795	1.54	1.04	2255	2.33	1.34	2921
	1150	19	1.25	0.67	2214	1.34	0.82	2727	2.08	1.12	3718
	850	14	1.07	0.55	2472	1.17	0.67	3021	1.84	0.96	4314
	100	1.7	0.18	0.09	3197	0.33	0.10	3623	0.43	0.17	6290
OVERHUNG LOAD*			INPUT SHAFT 400 LBS. OUTPUT SHAFT 1300 LBS.			INPUT SHAFT 550 LBS. OUTPUT SHAFT 1500 LBS.			INPUT SHAFT 600 LBS. OUTPUT SHAFT 2000 LBS.		
OUTPUT SHAFT THRUST LOAD			1000 LBS.			1100 LBS.			1300 LBS.		
MAXIMUM INPUT SPEED			3600 RPM			3600 RPM			3600 RPM		

*Overhung Load Rating is at center of shaft extension with no thrust load.

** Sizes 932 & larger are Fan Cooled (FC).

(FC) = Fan Cooled

Units must be derated 33% when operated without a fan.

900 Series – Right Angle, Quill Type, Solid Shaft, NEMA C-Face Input



H50 Reducer

900 Series Single Reduction

900 Series Double Reduction

Accessories

Ratio Multipliers

In-Line Helical (LH)

Universal Series Single Reduction

Universal Series Double Reduction

Engineering

Nominal Output RPM @ 1750 RPM In	Gear Ratio	Continuous Duty Output Torque (In-Lbs) Based on 1750 RPM Motor										Max Input Hp	Max Output Torque Rating In-Lbs	NEMA Motor Mount	Style Number	Catalog Number	Mult. Sym.	Ap'x Shpg. Wgt.	
		0.25	0.33	0.5	0.75	1	1.5	2	3	5	7.5								10
350	5:1		75	112	149								1.11	165	56C	F-913-05-B5-G	GF0513AG	GB	20
			75	112	149								1.11	165	56C	F-913-05-B5-J	GF0513AJ	GB	20
				115	154	231							1.50	231	56C	F-915-05-B5-G	GF0515AG	GB	25
				115	154	231							1.50	231	140TC	F-915-05-B7-G	GF0515BG	GB	25
				115	154	231							1.50	231	56C	F-915-05-B5-H	GF0515AH	GB	25
					160	240	320						2.00	320	56C	F-918-05-B5-G	GF0518AG	GB	30
					160	240	320						2.00	320	140TC	F-918-05-B7-G	GF0518BG	GB	30
						246	327	491					3.14	514	140TC	F-921-05-B7-G	GF0521BG	GB	35
						246	327	491					3.14	514	140TC	F-921-05-B7-J	GF0521BJ	GB	35
							339	507					4.17	705	180TC	F-924-05-B9-G	GF0524CG	GB	40
							339	508	847				5.43	919	180TC	F-926-05-B9-G	GF0526CG	GB	55
								502	837	1255			7.64	1279	180TC	F-930-05-B9-G	GF0530CG	GB	68
							837	1255	1674		13.7	2315	210TC	F-938-05-B11-H	GF0538DH	GB	126		
175	10:1		82	125	187							0.90	225	56C	F-913-10-B5-G	GF1013AG	GB	20	
			82	125	187							0.90	225	56C	F-913-10-B5-J	GF1013AJ	GB	20	
			82	125	187							0.90	225	56C	F-913-10-B5-H	GF1013AH	GB	20	
				141	211	282						1.03	290	56C	F-915-10-B5-G	GF1015AG	GB	20	
				141	211	282						1.03	290	140TC	F-915-10-B7-G	GF1015BG	GB	20	
				141	211	282						1.03	290	56C	F-915-10-B5-H	GF1015AH	GB	25	
					214	285	428						1.50	428	56C	F-918-10-B5-G	GF1018AG	GB	30
					214	285	428						1.50	428	56C	F-918-10-B5-J	GF1018AJ	GB	30
					214	285	428						1.50	428	56C	F-918-10-B5-H	GF1018AH	GB	29
					214	285	428						1.50	428	140TC	F-918-10-B7-G	GF1018BG	GB	30
						312	468	624					2.02	630	56C	F-921-10-B5-G	GF1021AG	GB	35
						312	468	624					2.02	630	56C	F-921-10-B5-J	GF1021AJ	GB	35
						312	468	624					2.02	630	56C	F-921G-10-B5-G	GF10G21AG	GB	30
						312	468	624					2.02	630	56C	F-921-10-B5-H	GF1021AH	GB	35
						312	468	624					2.02	630	140TC	F-921-10-B7-G	GF1021BG	GB	35
						317	475	634					2.73	893	140TC	F-924-10-B7-G	GF1024BG	GB	40
							655	983					3.59	1177	140TC	F-926-10-B7-G	GF1026BG	GB	55
							655	983					3.59	1177	180TC	F-926-10-B9-G	GF1026CG	GB	55
					641	961	1602				5.48	1755	180TC	F-930-10-B9-G	GF1030CG	GB	68		
						990	1649				6.36	2106	180TC	F-932-10-B9-G	GF1032CG	GB	87		
						963	1604	2407			9.05	2905	210TC	F-938-10-B11-G	GF1038DG	GB	126		
117	15:1		89	118	179							0.66	225	56C	F-913-15-B5-G	GF1513AG	GB	20	
			89	118	179							0.66	225	56C	F-913-15-B5-J	GF1513AJ	GB	20	
			89	118	179							0.66	225	56C	F-913-15-B5-H	GF1513AH	GB	20	
				127	193	289						0.81	312	56C	F-915-15-B5-G	GF1515AG	GB	25	
				127	193	289						0.81	312	56C	F-915-15-B5-H	GF1515AH	GB	25	
					209	314	419					1.07	448	56C	F-918-15-B5-G	GF1518AG	GB	30	
					209	314	419					1.07	448	56C	F-918-15-B5-J	GF1518AJ	GB	30	
					209	314	419					1.07	448	56C	F-918-15-B5-H	GF1518AH	GB	30	
					246	369	492					1.35	664	56C	F-921-15-B5-G	GF1521AG	GB	35	
					246	369	492					1.35	664	56C	F-921-15-B5-J	GF1521AJ	GB	35	
					246	369	492					1.35	664	56C	F-921-15-B5-H	GF1521AH	GB	35	
					246	369	492					1.35	664	140TC	F-921-15-B7-G	GF1521BG	GB	35	

Note: Service Class I Torque Ratings (1.0 Service Factor)
 Service Class II Torque Ratings (≥ 1.4 Service Factor)
 Service Class III Torque Ratings (≥ 2.0 Service Factor)

Vertical motor below gearhead not recommended. Avoiding those positions where the high speed oil seal is immersed in oil, will provide greater security against high speed input seal wear.

Replacement oil – 1 Qt P/N MJ0006A05SP (Klubersynth UH1-6-460)

Suffix: G = Left hand output facing input J = Right hand output facing input H = Double Output Shaft



900 Series – Right Angle, Quill Type, Solid Shaft, NEMA C-Face Input

Nominal Output RPM @ 1750 RPM In	Gear Ratio	Continuous Duty Output Torque (In-Lbs) Based on 1750 RPM Motor									Max Input Hp	Max Output Torque Rating In-Lbs	NEMA Motor Mount	Style Number	Catalog Number	Mult. Sym.	Ap'x Shpg. Wgt.	
		0.25	0.33	0.5	0.75	1	1.5	2	3	5								7.5
117	15:1					470	705	939				2.11	992	56C	F-924-15-B5-G	GF1524AG	GB	40
						470	705	939				2.11	992	56C	F-924-15-B5-J	GF1524AJ	GB	40
						470	705	939				2.11	992	140TC	F-924-15-B7-G	GF1524BG	GB	40
						473	710	947				2.58	1225	140TC	F-926-15-B7-G	GF1526BG	GB	55
							686	915	1373			4.14	1903	180TC	F-930-15-B9-G	GF1530CG	GB	68
								959	1438			4.66	2241	140TC	F-932-15-B7-G	GF1532BG	GB	87
									959	1438		4.66	2241	180TC	F-932-15-B9-G	GF1532CG	GB	87
								1409	2349	6.64	3118	180TC	F-938-15-B9-G	GF1538CG	GB	126		
88	20:1	113	149	226								0.53	239	56C	F-913-20-B5-G	GF2013AG	GB	20
		113	149	226								0.53	239	56C	F-913-20-B5-H	GF2013AH	GB	20
		128	169	256								0.62	317	56C	F-915-20-B5-G	GF2015AG	GB	25
		128	169	256								0.62	317	56C	F-915-20-B5-H	GF2015AH	GB	25
			165	251	376							0.92	461	56C	F-918-20-B5-G	GF2018AG	GB	30
			165	251	376							0.92	461	56C	F-918-20-B5-J	GF2018AJ	GB	30
			165	251	376							0.92	461	56C	F-918-20-B5-H	GF2018AH	GB	30
				323	484	645						1.06	684	56C	F-921-20-B5-G	GF2021AG	GB	35
				323	484	645						1.06	684	56C	F-921-20-B5-J	GF2021AJ	GB	35
				323	484	645						1.06	684	56C	F-921G-20-B5-G	GF20G21AG	GB	35
				323	484	645						1.06	684	56C	F-921-20-B5-H	GF2021AH	GB	35
				323	484	645						1.06	684	140TC	F-921-20-B7-G	GF2021BG	GB	35
				323	484	645						1.06	684	140TC	F-921G-20-B7-G	GF20G21BG	GB	30
					451	602	902					1.72	1038	56C	F-924-20-B5-G	GF2024AG	GB	40
					451	602	902					1.72	1038	140TC	F-924-20-B7-G	GF2024BG	GB	40
						609	913	1218				2.15	1308	56C	F-926-20-B5-G	GF2026AG	GB	55
						609	913	1218				2.15	1308	140TC	F-926-20-B7-G	GF2026BG	GB	55
							880	1174	1761			3.31	1955	140TC	F-930-20-B7-G	GF2030BG	GB	68
							880	1174	1761			3.31	1955	180TC	F-930-20-B9-G	GF2030CG	GB	68
							880	1174	1761			3.31	1955	180TC	F-930-20-B9-J	GF2030CJ	GB	68
					924	1232	1848			3.85	2383	140TC	F-932-20-B7-G	GF2032BG	GB	87		
					924	1232	1848			3.85	2383	180TC	F-932-20-B9-G	GF2032CG	GB	87		
						1176	1764	2940		5.43	3193	180TC	F-938-20-B9-G	GF2038CG	GB	126		
70	25:1	119	157	238							0.50	238	56C	F-913-25-B5-G	GF2513AG	GB	20	
		156	206	312							0.51	318	56C	F-915-25-B5-G	GF2515AG	GB	25	
		156	206	312							0.51	318	56C	F-915-25-B5-H	GF2515AH	GB	25	
			183	277	416							0.8	444	56C	F-918-25-B5-G	GF2518AG	GB	28
			183	277	416							0.8	444	56C	F-918-25-B5-J	GF2518AJ	GB	30
			250	379	569							0.89	675	56C	F-921-25-B5-G	GF2521AG	GB	35
			250	379	569							0.89	675	56C	F-921-25-B5-J	GF2521AJ	GB	35
			250	379	569							0.89	675	56C	F-921G-25-B5-G	GF25G21AG	GB	40
				365	547	729						1.37	1002	56C	F-924-25-B5-G	GF2524AG	GB	36
				365	547	729						1.37	1002	140TC	F-924-25-B7-G	GF2524BG	GB	40
					567	756	1134					1.73	1307	140TC	F-926-25-B7-G	GF2526BG	GB	55
						711	1066	1422				2.78	1978	56C	F-930-25-B5-G	GF2530AG	GB	68
						711	1066	1422				2.78	1978	140TC	F-930-25-B7-G	GF2530BG	GB	68
							1134	1513	2269			3.13	2355	140TC	F-932-25-B7-G	GF2532BG	GB	87
								1440	2160			4.50	3222	180TC	F-938-25-B9-H	GF2538CH	GB	126

Note: Service Class I Torque Ratings (1.0 Service Factor)
 Service Class II Torque Ratings (≥ 1.4 Service Factor)
 Service Class III Torque Ratings (≥ 2.0 Service Factor)

Vertical motor below gearhead not recommended. Avoiding those positions where the high speed oil seal is immersed in oil, will provide greater security against high speed input seal wear.

Replacement oil – 1 Qt P/N MJ0006A05SP (Klubersynth UH1-6-460)

Suffix: G = Left hand output facing input J = Right hand output facing input H = Double Output Shaft

900 Series – Right Angle, Quill Type, Solid Shaft, NEMA C-Face Input



H50 Reducer

900 Series Single Reduction

900 Series Double Reduction

Accessories

Ratio Multipliers

In-Line Helical (LH)

Universal Series Single Reduction

Universal Series Double Reduction

Engineering

Nominal Output RPM @ 1750 RPM In	Gear Ratio	Continuous Duty Output Torque (In-Lbs) Based on 1750 RPM Motor										Max Input Hp	Max Output Torque Rating In-Lbs	NEMA Motor Mount	Style Number	Catalog Number	Mult. Sym.	Ap'x Shpg. Wgt.
		0.25	0.33	0.5	0.75	1	1.5	2	3	5	7.5							
58	30:1	148	195									0.42	248	56C	F-913-30-B5-G	GF3013AG	GB	20
		148	195									0.42	248	56C	F-913-30-B5-H	GF3013AH	GB	20
		159	210	318								0.50	318	56C	F-915-30-B5-G	GF3015AG	GB	25
		159	210	318								0.50	318	56C	F-915-30-B5-H	GF3015AH	GB	25
			216	327								0.72	470	56C	F-918-30-B5-G	GF3018AG	GB	30
			216	327								0.72	470	56C	F-918-30-B5-J	GF3018AJ	GB	30
			216	327								0.72	470	56C	F-918-30-B5-H	GF3018AH	GB	30
			275	416	624							0.83	691	56C	F-921-30-B5-G	GF3021AG	GB	35
			275	416	624							0.83	691	56C	F-921-30-B5-J	GF3021AJ	GB	35
			275	416	624							0.83	691	56C	F-921-30-B5-H	GF3021AH	GB	35
			275	416	624							0.83	691	56C	F-921G-30-B5-G	GF30G21AG	GB	30
				420	630	840						1.32	1111	56C	F-924-30-B5-G	GF3024AG	GB	40
				420	630	840						1.32	1111	56C	F-924-30-B5-J	GF3024AJ	GB	40
				420	630	840						1.32	1111	140TC	F-924-30-B7-G	GF3024BG	GB	40
					641	854	1281					1.54	1313	56C	F-926-30-B5-G	GF3026AG	GB	55
					641	854	1281					1.54	1313	140TC	F-926-30-B7-G	GF3026BG	GB	55
						804	1206	1608				2.47	1978	56C	F-930-30-B5-G	GF3030AG	GB	68
						804	1206	1608				2.47	1978	56C	F-930-30-B5-J	GF3030AJ	GB	68
						804	1206	1608				2.47	1978	140TC	F-930-30-B7-G	GF3030BG	GB	68
						881	1322	1763				2.81	2482	140TC	F-932-30-B7-G	GF3032BG	GB	87
						1626	2438			3.97	3226	180TC	F-938-30-B9-G	GF3038CG	GB	126		
44	40:1	174	230								0.33	230	56C	F-913-40-BG-G	GF4013AG	GB	20	
		174	230								0.33	230	56C	F-913-40-B5-H	GF4013AH	GB	20	
		208	275								0.38	317	56C	F-915-40-B5-G	GF4015AG	GB	25	
		208	275								0.38	317	56C	F-915-40-B5-J	GF4015AJ	GB	25	
		180	238	360							0.64	461	56C	F-918-40-B5-G	GF4018AG	GB	30	
		180	238	360							0.64	461	56C	F-918-40-B5-J	GF4018AJ	GB	30	
			340	515								0.66	680	56C	F-921-40-B5-G	GF4021AG	GB	35
			340	515								0.66	680	56C	F-921-40-B5-J	GF4021AJ	GB	35
				521	781							0.99	1030	56C	F-924-40-B5-G	GF4024AG	GB	40
				521	781							0.99	1030	56C	F-924-40-B5-J	GF4024AJ	GB	40
				521	781							0.99	1030	56C	F-924-40-B5-H	GF4024AH	GB	40
				524	786	1049						1.23	1296	56C	F-926-40-B5-G	GF4026AG	GB	55
				524	786	1049						1.23	1296	56C	F-926-40-B5-J	GF4026AJ	GB	55
				524	786	1049						1.23	1296	140TC	F-926-40-B7-G	GF4026BG	GB	55
					794	1059	1589					1.84	1960	56C	F-930-40-B5-G	GF4030AG	GB	68
					794	1059	1589					1.84	1960	140TC	F-930-40-B7-G	GF4030BG	GB	68
						1180	1620	2160				2.20	2374	140TC	F-932-40-B7-G	GF4032BG	GB	87
							1596	2129	3192			3.00	3192	180TC	F-938-40-B9-G	GF4038CG	GB	126
					1596	2129	3192			3.00	3192	180TC	F-938-40-B9-H	GF4038CH	GB	126		

Note: Service Class I Torque Ratings (1.0 Service Factor)
 Service Class II Torque Ratings (≥ 1.4 Service Factor)
 Service Class III Torque Ratings (≥ 2.0 Service Factor)

Vertical motor below gearhead not recommended. Avoiding those positions where the high speed oil seal is immersed in oil, will provide greater security against high speed input seal wear.

Replacement oil – 1 Qt P/N MJ0006A05SP (Klubersynth UH1-6-460)

Suffix: G = Left hand output facing input J = Right hand output facing input H = Double Output Shaft

900 Series – Right Angle, Quill Type, Solid Shaft, NEMA C-Face Input



Nominal Output RPM @ 1750 RPM In	Gear Ratio	Continuous Duty Output Torque (In-Lbs) Based on 1750 RPM Motor										Max Input Hp	Max Output Torque Rating In-Lbs	NEMA Motor Mount	Style Number	Catalog Number	Mult. Sym.	Ap'x Shpg. Wgt.
		0.25	0.33	0.5	0.75	1	1.5	2	3	5	7.5							
35	50:1	177	234									0.33	234	56C	F-913-50-B5-G	GF5013AG	GB	20
		177	234									0.33	234	56C	F-913-50-B5-H	GF5013AH	GB	20
		230	303									0.33	303	56C	F-915-50-B5-G	GF5015AG	GB	25
		222	294									0.49	436	56C	F-918-50-B5-G	GF5018AG	GB	30
		222	294									0.49	436	56C	F-918-50-B5-J	GF5018AJ	GB	30
		280	370	561								0.58	651	56C	F-921-50-B5-G	GF5021AG	GB	35
		280	370	561								0.58	651	56C	F-921-50-B5-J	GF5021AJ	GB	35
		280	370	561								0.58	651	56C	F-921-50-B5-H	GF5021AH	GB	35
			401	608	912							0.83	1014	56C	F-924-50-B5-G	GF5024AG	GB	40
				621	932	1242						1.00	1242	56C	F-926-50-B5-G	GF5026AG	GB	55
				621	932	1242						1.00	1242	140TC	F-926-50-B7-G	GF5026BG	GB	55
					850	1134	1701					1.67	1890	56C	F-930-50-B5-G	GF5030AG	GB	68
					850	1134	1701					1.67	1890	140TC	F-930-50-B7-G	GF5030BG	GB	68
					958	1278	1917					1.83	2366	56C	F-932-50-B5-G	GF5032AG	GB	87
					958	1278	1917					1.83	2366	140TC	F-932-50-B7-G	GF5032BG	GB	87
						1152	1729	2305				2.67	3076	140TC	F-938-50-B7-G	GF5038BG	GB	126
						1152	1729	2305				2.67	3076	140TC	F-938-50-B7-H	GF5038BH	GB	126
		29	60:1	218	288								0.33	288	56C	F-915-60-B5-G	GF6015AG	GB
218	288										0.33	288	56C	F-915-60-B5-H	GF6015AH	GB	25	
220	290										0.47	413	56C	F-918-60-B5-G	GF6018AG	GB	30	
220	290										0.47	413	56C	F-918-60-B5-J	GF6018AJ	GB	30	
220	290										0.47	413	56C	F-918-60-B5-H	GF6018AH	GB	30	
317	418			634							0.50	634	56C	F-921-60-B5-G	GF6021AG	GB	35	
317	418			634							0.50	634	56C	F-921-60-B5-H	GF6021AH	GB	35	
317	418			634							0.50	634	56C	F-921-60-B5-J	GF6021AJ	GB	35	
	458			693								0.69	958	56C	F-924-60-B5-G	GF6024AG	GB	40
	458			693								0.69	958	56C	F-924-60-B5-J	GF6024AJ	GB	40
	473			716	1074							0.82	1166	56C	F-926-60-B5-G	GF6026AG	GB	55
	473			716	1074							0.82	1166	56C	F-926-60-B5-J	GF6026AJ	GB	55
	473			716	1074							0.82	1166	56C	F-926-60-B5-H	GF6026AH	GB	55
					896	1195	1795					1.50	1795	56C	F-930-60-B5-G	GF6030AG	GB	68
					896	1195	1795					1.50	1795	140TC	F-930-60-B7-G	GF6030BG	GB	68
					1100	1467	2200					1.54	2255	56C	F-932-60-B5-G	GF6032AG	GB	87
					1100	1467	2200					1.54	2255	140TC	F-932-60-B7-G	GF6032BG	GB	87
						1254	1881	2508				2.33	2921	140TC	F-938-60-B7-G	GF6038BG	GB	126
				1254	1881	2508				2.33	2921	140TC	F-938-60-B7-H	GF6038BH	GB	126		

Note: Service Class I Torque Ratings (1.0 Service Factor)
 Service Class II Torque Ratings (≥ 1.4 Service Factor)
 Service Class III Torque Ratings (≥ 2.0 Service Factor)

Vertical motor below gearhead not recommended. Avoiding those positions where the high speed oil seal is immersed in oil, will provide greater security against high speed input seal wear.

Replacement oil – 1 Qt P/N MJ0006A05SP (Klubersynth UH1-6-460)

Suffix: G = Left hand output facing input J = Right hand output facing input H = Double Output Shaft

900 Series – Right Angle, Quill Type, Hollow Shaft, NEMA C-Face Input



HF0
Reducer

900 Series
Single Reduction

900 Series
Double Reduction

Accessories

Ratio Multipliers

In-Line Helical (LH)

Universal Series
Single Reduction

Universal Series
Double Reduction

Engineering

Nominal Output RPM @ 1750 RPM In	Gear Ratio	Continuous Duty Output Torque (In-Lbs) Based on 1750 RPM Motor									Max Input Hp	Max Output Torque Rating In-Lbs	NEMA Motor Mount	Style Number	Catalog Number	Mult. Sym.	Ap'x Shpg. Wgt.	
		0.25	0.33	0.5	0.75	1	1.5	2	3	5								7.5
350	5:1		75	112	149						1.00	165	56C	HF-913-05-B5-H	GHF0513AH	GB	20	
						160	240	320			2.00	320	56C	HF-918-05-B5-H	GHF0518AH	GB	30	
175	10:1			214	285	428					1.50	428	56C	HF-918-10-B5-H	GHF1018AH	GB	30	
						312	468	624			2.02	630	56C	HF-921-10-B5-H	GHF1021AH	GB	35	
117	15:1						641	961	1602		5.48	1755	180TC	HF-930-10-B9-H	GHF1030CH	GB	75	
		89	118	179							0.66	25	56C	HF-913-15-B5-H	GHF1513AH	GB	20	
				209	314	419					1.07	448	56C	HF-918-15-B5-H	GHF1518AH	GB	30	
				246	369	492					1.35	664	56C	HF-921-15-B5-H	GHF1521AH	GB	35	
						470	705	939			2.11	992	56C	HF-924-15-B5-H	GHF1524AH	GB	45	
88	20:1										4.14	1903	140TC	HF-930-15-B7-H	GHF1530BH	GB	75	
		113	149	226							0.53	239	56C	HF-913-20-B5-H	GHF2013AH	GB	20	
			165	251	376						0.92	461	56C	HF-918-20-B5-H	GHF2018AH	GB	30	
				323	484	645					1.06	684	56C	HF-921-20-B5-H	GHF2021AH	GB	35	
					451	602	902				1.72	1038	56C	HF-924-20-B5-H	GHF2024AH	GB	45	
70	25										2.15	1309	56C	HF-926-20-B5-H	GHF2026AH	GB	56	
						609	913	1218				3.31	1955	140TC	HF-930-20-B7-H	GHF2030BH	GB	75
			183	277	416							0.80	444	56C	HF-918-25-B5-H	GHF2518AH	GB	23
			250	379	569							0.89	675	56C	HF-921-25-B5-H	GHF2521AH	GB	32
					567	756	1134					1.73	1307	140TC	HF-926-25-B7-H	GHF2526BH	GB	44
58	30:1										2.78	1978	140TC	HF-930-25-B7-H	GHF2530BH	GB	88	
		148	195								0.42	248	56C	HF-913-30-B5-H	GHF3013AH	GB	20	
			216	327							0.72	470	56C	HF-918-30-B5-H	GHF3018AH	GB	30	
			275	416	624						0.83	691	56C	HF-921-30-B5-H	GHF3021AH	GB	35	
				420	630	840					1.32	1111	56C	HF-924-30-B5-H	GHF3024AH	GB	45	
44	40:1										1.54	1313	56C	HF-926-30-B5-H	GHF3026AH	GB	56	
					641	854	1281				2.47	1978	140TC	HF-930-30-B7-H	GHF3030BH	GB	75	
						804	1206	1608			2.81	2462	140TC	HF-932-30-B7-H	GHF3032BH	GB	95	
			180	238	360						0.64	461	56C	HF-918-40-B5-H	GHF4018AH	GB	30	
				340	515						0.66	680	56C	HF-921-40-B5-H	GHF4021AH	GB	35	
35	50:1										0.99	1030	56C	HF-924-40-B5-H	GHF4024AH	GB	45	
					521	781					1.23	1296	56C	HF-926-40-B5-H	GHF4026AH	GB	56	
					524	786	1049				1.23	1296	140TC	HF-926-40-B7-H	GHF4026BH	GB	56	
					524	786	1049				2.20	2374	140TC	HF-932-40-B7-H	GHF4032BH	GB	95	
						1074	1611	2148										
29	60:1										0.33	234	56C	HF-913-50-B5-H	GHF5013AH	GB	20	
											0.49	436	56C	HF-918-50-B5-H	GHF5018AH	GB	30	
			177	234							0.58	651	56C	HF-921-50-B5-H	GHF5021AH	GB	35	
			222	294							0.83	1014	56C	HF-924-50-B5-H	GHF5024AH	GB	45	
			280	370	561						1.67	1890	56C	HF-930-50-B5-H	GHF5030AH	GB	75	
29	60:1										1.83	2366	56C	HF-932-50-B5-H	GHF5032AH	GB	95	
											0.47	413	56C	HF-918-60-B5-H	GHF6018AH	GB	30	
			220	290							0.50	634	56C	HF-921-60-B5-H	GHF6021AH	GB	35	
			317	418	634						0.69	958	56C	HF-924-60-B5-H	GHF6024AH	GB	45	
				458	693						0.82	1166	56C	HF-926-60-B5-H	GHF6026AH	GB	56	
29	60:1										1.50	1795	56C	HF-930-60-B5-H	GHF6030AH	GB	75	
					473	716	1074				1.54	2255	56C	HF-932-60-B5-H	GHF6032AH	GB	95	
					896	1195	1795											

Note: Service Class I Torque Ratings (1.0 Service Factor)
 Service Class II Torque Ratings (≥ 1.4 Service Factor)
 Service Class III Torque Ratings (≥ 2.0 Service Factor)

Vertical motor below gearhead not recommended. Avoiding those positions where the high speed oil seal is immersed in oil, will provide greater security against high speed input seal wear.

Replacement oil – 1 Qt P/N MJ0006A05SP (Klubersynth UH1-6-460)

Suffix: G = Left hand output facing input J = Right hand output facing input H = Double Output Shaft



Stainless Steel – Right Angle, Quill Type, Solid Shaft, NEMA C-Face Input

Nominal Output RPM @ 1750 RPM In	Gear Ratio	Continuous Duty Output Torque (In-Lbs) Based on 1750 RPM Motor									Max Input Hp	Max Output Torque Rating In-Lbs	NEMA Motor Mount	Style Number	Catalog Number	Mult. Sym.	Ap'x Shpg. Wgt.		
		0.25	0.33	0.5	0.75	1	1.5	2	3	5								7.5	
350	5:1					160	240	320				2.00	320	56C	SSF-918-05-B5-G	SSGF0518AG	GB	30	
						160	240	320				2.00	320	140TC	SSF-918-05-B7-G	SSGF0518BG	GB	30	
								246	327	491			3.14	514	140TC	SSF-921-05-B7-G	SSGF0521BG	GB	35
									339	508	847		5.43	919	140TC	SSF-926-05-B7-G	SSGF0526BG	GB	65
175	10:1				214	285	428					1.50	428	56C	SSF-918-10-B5-G	SSGF1018AG	GB	30	
					214	285	428					1.50	428	140TC	SSF-918-10-B7-G	SSGF1018BG	GB	30	
						312	468	624					2.02	630	140TC	SSF-921-10-B7-G	SSGF1021BG	GB	35
								655	983				3.59	1177	140TC	SSF-926-10-B7-G	SSGF1026BG	GB	65
117	15:1			209	314	419						1.07	448	56C	SSF-918-15-B5-G	SSGF1518AG	GB	30	
				246	369	492							1.35	664	56C	SSF-921-15-B5-G	SSGF1521AG	GB	35
						473	710	947					2.58	1225	140TC	SSF-926-15-B7-G	SSGF1526BG	GB	65
88	20:1		165	251	376							0.92	461	56C	SSF-918-20-B5-G	SSGF2018AG	GB	30	
				323	484	645							1.06	684	56C	SSF-921-20-B5-G	SSGF2021AG	GB	35
						609	913	1218					2.15	1308	140TC	SSF-926-20-B7-G	SSGF2026BG	GB	65
70	25:1		183	277	416							0.80	444	56C	SSF-918-25-B5-G	SSGF2518AG	GB	30	
				250	379	569							0.89	675	56C	SSF-921-25-B5-G	SSGF2521AG	GB	35
						567	756	1134					1.73	1307	140TC	SSF-926-25-B7-G	SSGF2526BG	GB	65
58	30:1		216	327								0.72	470	56C	SSF-918-30-B5-G	SSGF3018AG	GB	30	
				275	416	624							0.83	691	56C	SSF-921-30-B5-G	SSGF3021AG	GB	35
						641	854	1281					1.54	1313	140TC	SSF-926-30-B7-G	SSGF3026BG	GB	65
44	40:1		180	238	360							0.64	461	56C	SSF-918-40-B5-G	SSGF4018AG	GB	30	
				340	515								0.66	680	56C	SSF-921-40-B5-G	SSGF4021AG	GB	35
					524	786	1049						1.23	1296	140TC	SSF-926-40-B7-G	SSGF4026BG	GB	65
35	50:1		222	294								0.49	436	56C	SSF-918-50-B5-G	SSGF5018AG	GB	30	
				280	370	561							0.58	651	56C	SSF-921-50-B5-G	SSGF5021AG	GB	35
					621	932	1242						1.00	1242	56C	SSF-926-50-B5-G	SSGF5026AG	GB	65
29	60:1		220	290								0.47	413	56C	SSF-918-60-B5-G	SSGF6018AG	GB	30	
				317	418	634							0.50	634	56C	SSF-921-60-B5-G	SSGF6021AG	GB	35
					473	716	1074						0.82	1166	56C	SSF-926-60-B5-G	SSGF6026AG	GB	65

Note: Service Class I Torque Ratings (1.0 Service Factor)
 Service Class II Torque Ratings (≥ 1.4 Service Factor)
 Service Class III Torque Ratings (≥ 2.0 Service Factor)

Vertical motor below gearhead not recommended. Avoiding those positions where the high speed oil seal is immersed in oil, will provide greater security against high speed input seal wear.

Replacement oil – 1 Qt P/N MJ0006A05SP (Klubersynth UH1-6-460)

Suffix: G = Left hand output facing input J = Right hand output facing input H = Double Output Shaft

H50 Reducer

900 Series Single Reduction

900 Series Double Reduction

Accessories

Ratio Multiplier

In-Line Helical (LH)

Universal Series Single Reduction

Universal Series Double Reduction

Engineering

Stainless Steel – Right Angle, Quill Type, Hollow Shaft, NEMA C-Face Input



H50 Reducer

900 Series Single Reduction

900 Series Double Reduction

Accessories

Ratio Multipliers

In-Line Helical (LH)

Universal Series Single Reduction

Universal Series Double Reduction

Engineering

Nominal Output RPM @ 1750 RPM In	Gear Ratio	Continuous Duty Output Torque (In-Lbs) Based on 1750 RPM Motor									Max Input Hp	Max Output Torque Rating In-Lbs	NEMA Motor Mount	Style Number	Catalog Number	Mult. Sym.	Ap'x Shpg. Wgt.	
		0.25	0.33	0.5	0.75	1	1.5	2	3	5								7.5
350	5:1					160	240	320			2.00	320	56C	SSHF-918-05-B5-H	SSGHF0518AH	GB	30	
175	10:1				214	285	428				1.50	428	56C	SSHF-918-10-B5-H	SSGHF1018AH	GB	30	
						312	468	624				2.20	630	56C	SSHF-921-10-B5-H	SSGHF1021AH	GB	38
117	15:1										6.36	2106	180TC	SSHF-932-10-B9-H	SSGHF1032CH	GB	100	
				209	314	419						1.07	448	56C	SSHF-918-15-B5-H	SSGHF1518AH	GB	30
				246	369	492						1.35	664	56C	SSHF-921-15-B5-H	SSGHF1521AH	GB	38
88	20:1										4.66	2241	180TC	SSHF-932-15-B9-H	SSGHF1532CH	GB	100	
			165	251	376							0.92	461	56C	SSHF-918-20-B5-H	SSGHF2018AH	GB	30
				323	484	645						1.06	684	56C	SSHF-921-20-B5-H	SSGHF2021AH	GB	38
58	30:1										2.15	1309	56C	SSHF-926-20-B5-H	SSGHF2026AH	GB	60	
												3.85	2383	180TC	SSHF-932-20-B9-H	SSGHF2032CH	GB	100
												0.72	470	56C	SSHF-918-30-B5-H	SSGHF3018AH	GB	30
44	40:1										0.83	691	56C	SSHF-921-30-B5-H	SSGHF3021AH	GB	38	
			216	327								1.54	1313	56C	SSHF-926-30-B5-H	SSGHF3026AH	GB	60
			275	416	624							2.81	2482	140TC	SSHF-932-30-B7-H	SSGHF3032BH	GB	100
35	50:1										0.64	461	56C	SSHF-918-40-B5-H	SSGHF4018AH	GB	30	
												0.66	680	56C	SSHF-921-40-B5-H	SSGHF4021AH	GB	38
												1.23	1296	56C	SSHF-926-40-B5-H	SSGHF4026AH	GB	60
29	60:1										1.23	1296	140TC	SSHF-926-40-B7-H	SSGHF4026BH	GB	60	
												2.2	2374	140TC	SSHF-932-40-B7-H	SSGHF4032BH	GB	100
												0.49	436	56C	SSHF-918-50-B5-H	SSGHF5018AH	GB	30
35	50:1										0.58	651	56C	SSHF-921-50-B5-H	SSGHF5021AH	GB	38	
												1.00	1242	56C	SSHF-926-50-B5-H	SSGHF5026AH	GB	53
												1.83	2366	140TC	SSHF-932-50-B7-H	SSGHF5032BH	GB	100
29	60:1										0.47	413	56C	SSHF-918-60-B5-H	SSGHF6018AH	GB	30	
												0.50	634	56C	SSHF-921-60-B5-H	SSGHF6021AH	GB	38
												0.82	1166	56C	SSHF-926-60-B5-H	SSGHF6026AH	GB	60
											1.54	2255	140TC	SSHF-932-60-B7-H	SSGHF6032BH	GB	100	

- Note:**
- Service Class I Torque Ratings (1.0 Service Factor)
 - Service Class II Torque Ratings (≥ 1.4 Service Factor)
 - Service Class III Torque Ratings (≥ 2.0 Service Factor)

Vertical motor below gearhead not recommended. Avoiding those positions where the high speed oil seal is immersed in oil, will provide greater security against high speed input seal wear.

Replacement oil – 1 Qt P/N MJ0006A05SP (Klubersynth UH1-6-460)

Suffix: G = Left hand output facing input J = Right hand output facing input H = Double Output Shaft



Washdown – Right Angle, Quill Type, Solid Shaft, NEMA C-Face Input

Nominal Output RPM @ 1750 RPM In	Gear Ratio	Continuous Duty Output Torque (In-Lbs) Based on 1750 RPM Motor									Max Input Hp	Max Output Torque Rating In-Lbs	NEMA Motor Mount	Style Number	Catalog Number	Mult. Sym.	Ap'x Shpg. Wgt.	
		0.25	0.33	0.5	0.75	1	1.5	2	3	5								7.5
350	5:1					160	240	320			2.00	320	56C	WDF-918-05-B5-G	WDGF0518AG	GB	30	
175	10:1		82	125	187						0.90	225	56C	WDF-913-10-B5-G	WDGF1013AG	GB	20	
				141	211	282					1.03	290	56C	WDF-915-10-B5-G	WDGF1015AG	GB	25	
					141	211	282					1.03	290	140TC	WDF-915-10-B7-G	WDGF1015BG	GB	25
						214	285	428				1.50	428	56C	WDF-918-10-B5-G	WDGF1018AG	GB	30
							312	468	624			2.20	630	56C	WDF-921-10-B5-G	WDGF1021AG	GB	35
								317	475	634		2.73	893	140TC	WDF-924-10-B7-G	WDGF1024BG	GB	40
117	15:1		89	118	179						0.66	225	56C	WDF-913-15-B5-G	WDGF1513AG	GB	20	
				127	193	289					0.81	312	56C	WDF-915-15-B5-G	WDGF1515AG	GB	25	
					209	314	419				1.07	448	56C	WDF-918-15-B5-G	WDGF1518AG	GB	30	
						246	369	492			1.35	664	56C	WDF-921-15-B5-G	WDGF1521AG	GB	35	
								470	705	939		2.11	992	56C	WDF-924-15-B5-G	WDGF1524AG	GB	40
88	20:1		113	149	226						0.53	239	56C	WDF-913-20-B5-G	WDGF2013AG	GB	20	
				128	169	256					0.62	317	56C	WDF-915-20-B5-G	WDGF2015AG	GB	25	
					165	251	376				0.92	461	56C	WDF-918-20-B5-G	WDGF2018AG	GB	30	
							609	913	1218		2.15	1309	140TC	WDF-926-20-B7-G	WDGF2026BG	GB	55	
58	30:1		216	327							0.72	470	56C	WDF-918-30-B5-G	WDGF3018AG	GB	30	
				275	416	624					0.83	691	56C	WDF-921-30-B5-G	WDGF3021AG	GB	35	
					420	630	840				1.32	111	56C	WDF-924-30-B5-G	WDGF3024AG	GB	40	
						641	854	1281			1.54	1313	56C	WDF-926-30-B5-G	WDGF3026AG	GB	55	
								881	1322	1763		2.81	2462	140TC	WDF-932-30-B7-G	WDGF3032BG	GB	87
44	40:1		208	275							0.44	317	56C	WDF-915-40-B5-G	WDGF4015AG	GB	25	
				180	238	360					0.64	461	56C	WDF-918-40-B5-G	WDGF4018AG	GB	30	
					340	515					0.66	680	56C	WDF-921-40-B5-G	WDGF4021AG	GB	35	
						521	781				0.99	1030	56C	WDF-924-40-B5-G	WDGF4024AG	GB	40	
							524	786	1049		1.23	1296	56C	WDF-926-40-B5-G	WDGF4026AG	GB	55	
								1081	1622	2163		2.20	2374	140TC	WDF-932-40-B7-G	WDGF4032BG	GB	87
35	50:1		177	234							0.33	234	56C	WDF-913-50-B5-G	WDGF5013AG	GB	20	
				230	303						0.33	303	56C	WDF-915-50-B5-G	WDGF5015AG	GB	25	
					280	370	561				0.58	651	56C	WDF-921-50-B5-G	WDGF5021AG	GB	35	
						401	608	912			0.83	1014	56C	WDF-924-50-B5-G	WDGF5024AG	GB	40	
							621	932	1242		1.00	1242	56C	WDF-926-50-B5-G	WDGF5026AG	GB	55	
								958	1278	1917		1.83	2366	140TC	WDF-932-50-B7-G	WDGF5032BG	GB	92
29	60:1		218	288							0.33	288	56C	WDF-915-60-B5-G	WDGF6015AG	GB	25	
				220	290						0.47	413	56C	WDF-918-60-B5-G	WDGF6018AG	GB	30	
					317	418	634				0.50	634	56C	WDF-921-60-B5-G	WDGF6021AG	GB	35	
						458	693				0.69	956	56C	WDF-924-60-B5-G	WDGF6024AG	GB	40	
							473	716	1074		0.82	1166	56C	WDF-926-60-B5-G	WDGF6026AG	GB	55	
								1100	1467	2200		1.54	2255	56C	WDF-932-60-B5-G	WDGF6032AG	GB	87

Note: Service Class I Torque Ratings (1.0 Service Factor)
 Service Class II Torque Ratings (≥ 1.4 Service Factor)
 Service Class III Torque Ratings (≥ 2.0 Service Factor)

Vertical motor below gearhead not recommended. Avoiding those positions where the high speed oil seal is immersed in oil, will provide greater security against high speed input seal wear.

Replacement oil – 1 Qt P/N MJ0006A05SP (Klubersynth UH1-6-460)

Suffix: G = Left hand output facing input J = Right hand output facing input H = Double Output Shaft

900 Series – Right Angle, Coupling Type, Solid Shaft, NEMA C-Face Input



H50 Reducer

900 Series Single Reduction

900 Series Double Reduction

Accessories

Ratio Multipliers

In-Line Helical (LH)

Universal Series Single Reduction

Universal Series Double Reduction

Engineering

Nominal Output RPM @ 1750 RPM In	Gear Ratio	Continuous Duty Output Torque (In-Lbs) Based on 1750 RPM Motor									Max Input Hp	Max Output Torque Rating In-Lbs	NEMA Motor Mount	Style Number	Catalog Number	Mult. Sym.	Ap'x Shpg. Wgt.	
		0.25	0.33	0.5	0.75	1	1.5	2	3	5								7.5
350	5:1				115	154	231				1.50	231	56C	LF-915-05-B5-G	GLF0515AG	GB	30	
223	7.5:1					237	356	474			2.70	640	56C	LF-921-7.5-B5-G	GLF0821AG	GB	38	
						237	356	474			2.70	640	56C	LF-921-7.5-B5-J	GLF0821AJ	GB	38	
						237	356	474			2.70	640	140TC	LF-921-7.5-B7-G	GLF0821BG	GB	38	
								501	752			4.30	1079	140TC	LF-926-7.5-B7-G	GLF0826BG	GB	60
								501	752			4.30	1079	180TC	LF-926-7.5-B9-G	GLF0826CG	GB	60
175	10:1			214	285	428					1.50	428	56C	LF-918-10-B5-G	GLF1018AG	GB	32	
					312	468	624				2.02	630	56C	LF-921-10-B5-G	GLF1021AG	GB	38	
					312	468	624				2.02	630	140TC	LF-921-10-B7-G	GLF1021BG	GB	38	
					312	468	624				2.02	630	140TC	LF-921-10-B7-J	GLF1021BJ	GB	38	
					317	475	634				2.73	893	140TC	LF-924-10-B7-G	GLF1024BG	GB	45	
								655	983			3.59	1177	140TC	LF-926-10-B7-G	GLF1026BG	GB	60
								655	983			3.59	1177	180TC	LF-926-10-B9-G	GLF1026CG	GB	60
117	15:1								990	1649	6.36	2106	180TC	LF-932-10-B9-G	GLF1032CG	GB	100	
		89	118	179							0.66	2228	56C	LF-913-15-B5-G	GLF1513AG	GB	20	
				246	369	492						1.35	664	56C	LF-921-15-B5-G	GLF1521AG	GB	38
				246	369	492						1.35	664	56C	LF-921-15-B5-J	GLF1521AJ	GB	38
						473	710	947				2.58	1225	140TC	LF-926-15-B7-G	GLF1526BG	GB	60
						473	710	947				2.58	1225	140TC	LF-926-15-B7-J	GLF1526BJ	GB	60
								959	1438			4.66	2241	180TC	LF-932-15-B9-G	GLF1532CG	GB	100
88	20:1										0.53	239	56C	LF-913-20-B5-G	GLF2013AG	GB	20	
				113	149	226						0.92	464	56C	LF-918-20-B5-G	GLF2018AG	GB	32
				165	251	376						1.06	684	56C	LF-921-20-B5-G	GLF2021AG	GB	38
	20:1				323	484	645					1.06	684	56C	LF-921-20-B5-J	GLF2021AJ	GB	38
					323	484	645					1.06	684	56C	LF-921-20-B5-G	GLF2021AG	GB	38
						609	913	1218				2.15	1308	140TC	LF-926-20-B7-G	GLF2026BG	GB	60
						609	913	1218				2.15	1308	140TC	LF-926-20-B7-J	GLF2026BJ	GB	60
						924	1232	1848			3.85	2383	180TC	LF-932-20-B9-G	GLF2032CG	GB	100	
70	25:1			156	296	312					0.51	318	56C	LF-915-25-B5-G	GLF2515AG	GB	30	
				183	277	416						0.80	444	56C	LF-918-25-B5-B	GLF2518AG	GB	32
				250	379	549						0.89	675	56C	LF-921-25-B5-G	GLF2521AG	GB	38
				250	379	569						0.89	675	56C	LF-921-25-B5-J	GLF2521AJ	GB	38
						567	756	1134				1.73	1307	56C	LF-926-25-B5-G	GLF2526AG	GB	60
						567	756	1134				1.73	1307	140TC	LF-926-25-B7-G	GLF2526BG	GB	60
						567	756	1134				1.73	1307	140TC	LF-926-25-B7-J	GLF2526BJ	GB	60
Universal Series Double Reduction						1134	1513	2269			3.13	2355	140TC	LF-932-25-B7-G	GLF2532BG	GB	100	
						1134	1513	2269			3.13	2355	180TC	LF-932-25-B9-G	GLF2532CG	GB	100	
						1134	1513	2269			3.13	2355	180TC	LF-932-25-B9-J	GLF2532CJ	GB	100	

Note: Service Class I Torque Ratings (1.0 Service Factor)
 Service Class II Torque Ratings (≥ 1.4 Service Factor)
 Service Class III Torque Ratings (≥ 2.0 Service Factor)

Vertical motor below gearhead not recommended. Avoiding those positions where the high speed oil seal is immersed in oil, will provide greater security against high speed input seal wear.
 Replacement oil – 1 Qt P/N MJ0006A05SP (Klubersynth UH1-G-460)

Suffix: G = Left hand output facing input J = Right hand output facing input H = Double Output Shaft

900 Series – Right Angle, Coupling Type, Solid Shaft, NEMA C-Face Input



Nominal Output RPM @ 1750 RPM In	Gear Ratio	Continuous Duty Output Torque (In-Lbs) Based on 1750 RPM Motor										Max Input Hp	Max Output Torque Rating In-Lbs	NEMA Motor Mount	Style Number	Catalog Number	Mult. Sym.	Ap'x Shpg. Wgt.
		0.25	0.33	0.5	0.75	1	1.5	2	3	5	7.5							
58	30:1	148	195									0.42	248	56C	LF-913-30-B5-G	GLF3013AG	GB	20
		159	210	318								0.50	318	56C	LF-915-30-B5-G	GLF3015AG	GB	30
			216	327								0.72	470	56C	LF-918-30-B5-G	GLF3018AG	GB	32
			216	327								0.72	470	56C	LF-918-30-B5-J	GLF3018AJ	GB	32
			275	416	624							0.83	691	56C	LF-921-30-B5-G	GLF3021AG	GB	38
				420	630	840						1.32	1111	56C	LF-924-30-B5-G	GLF3024AG	GB	45
					641	854	1281					1.54	1313	140TC	LF-926-30-B7-G	GLF3026BG	GB	60
					641	854	1281					1.54	1313	140TC	LF-926-30-B7-J	GLF3026BJ	GB	60
						881	1322	1763				2.81	2482	180TC	LF-932-30-B9-G	GLF3032CG	GB	100
								1626	2438			3.97	3226	180TC	LF-938-30-B9-G	GLF3038CG	GB	130
44	40:1	180	238	360							0.64	461	56C	LF-918-40-B5-G	GLF4018AG	GB	32	
				521	781						0.99	1030	56C	LF-924-40-B5-G	GLF4024AG	GB	45	
				524	786	1049					1.23	1296	56C	LF-926-40-B5-G	GLF4026AG	GB	60	
						1180	1620	2160			2.20	2374	140TC	LF-932-40-B7-G	GLF4032BG	GB	100	
							1596	2129	3192		3.00	3192	180TC	LF-938-40-B9-G	GLF4038CG	GB	130	
35	50:1	280	370	561							0.58	651	56C	LF-921-50-B5-G	GLF5021AG	GB	38	
				621	932	1242					1.00	1242	56C	LF-926-50-B5-G	GLF5026AG	GB	60	
29	60:1	218	288								0.33	288	56C	LF-915-60-B5-G	GLF6015AG	GB	30	
		220	290								0.47	413	56C	LF-918-60-B5-G	GLF6018AG	GB	32	
		317	418	634							0.50	634	56C	LF-921-60-B5-G	GLF6021AG	GB	38	
			473	716	1074						0.82	1166	56C	LF-926-60-B5-G	GLF6026AG	GB	60	
					1100	1467	2200				1.54	2255	56C	LF-932-60-B5-G	GLF6032AG	GB	100	
					1100	1467	2200				1.54	2255	140TC	LF-932-60-B7-G	GLF6032BG	GB	100	

Note: Service Class I Torque Ratings (1.0 Service Factor)
 Service Class II Torque Ratings (≥ 1.4 Service Factor)
 Service Class III Torque Ratings (≥ 2.0 Service Factor)

Vertical motor below gearhead not recommended. Avoiding those positions where the high speed oil seal is immersed in oil, will provide greater security against high speed input seal wear.

Replacement oil – 1 Qt P/N MJ0006A05SP (Klubersynth UH1-6-460)

Suffix: G = Left hand output facing input J = Right hand output facing input H = Double Output Shaft

H50 Reducer

900 Series Single Reduction

900 Series Double Reduction

Accessories

Ratio Multiplier

In-Line Helical (LH)

Universal Series Single Reduction

Universal Series Double Reduction

Engineering

900 Series – Right Angle, Solid Worm, Projecting Input Shaft



H50 Reducer

900 Series Single Reduction

900 Series Double Reduction

Accessories

Ratio Multipliers

In-Line Helical (LH)

Universal Series Single Reduction

Universal Series Double Reduction

Engineering

Nominal Output RPM @ 1750 RPM In	Gear Ratio	Continuous Duty Output Torque (In-Lbs) Based on 1750 RPM Motor									Max Input Hp	Max Output Torque Rating In-Lbs	Style Number	Catalog Number	Mult. Sym.	Ap'x Shpg. Wgt.
		0.25	0.33	0.5	0.75	1	1.5	2	3	5						
175	10:1				214	285	428				1.50	428	S-918-10-G	GS1018G	GB	25
						312	468	624			2.02	630	S-921-10-G	GS1021G	GB	28
								492	655			3.59	1177	S-926-10-G	GS1026G	GB
117	15:1	96	127	193							0.66	225	S-915-15-G	GS1515G	GB	21
				209	314	419					1.07	448	S-918-15-G	GS1518G	GB	25
				246	369	492					1.35	664	S-921-15-G	GS1521G	GB	28
88	20:1		165	251	376						0.92	461	S-918-20-G	GS2018G	GB	25
				323	484	645					1.06	684	S-921-20-G	GS2021G	GB	28
					451	602	902				1.72	1038	S-924-20-G	GS2024G	GB	38
						609	913	1218			2.15	1308	S-926-20-G	GS2026G	GB	50
58	30:1	156	206	312							0.51	318	S-915-25-G	GS2515G	GB	21
		148	195								0.42	248	S-913-30-G	GS3013G	GB	18
			216	327							0.72	470	S-918-30-G	GS3018G	GB	25
			275	416	624						0.83	691	S-921-30-G	GS3021G	GB	28
44	40:1			641	854	1281					1.54	1313	S-926-30-G	GS3026G	GB	50
		208	275								0.38	317	S-915-40-G	GS4015G	GB	21
		180	238	360							0.64	461	S-918-40-G	GS4018G	GB	25
			340	515							0.66	680	S-921-40-G	GS4021G	GB	28
35	50:1			524	786	1049					1.23	1296	S-926-40-G	GS4026G	GB	50
		222	294								0.49	436	S-918-50-G	GS5018G	GB	25
		280	370	561							0.59	651	S-921-50-G	GS5021G	GB	28
29	60:1			621	932	1242					1.00	1242	S-926-50-G	GS5026G	GB	50
		179									0.28	201	S-913-60-G	GS6013G	GB	18
		218	288								0.33	288	S-915-60-G	GS6015G	GB	21
		220	290								0.47	413	S-918-60-G	GS6018G	GB	25
		317	418	634							0.50	634	S-921-60-G	GS6021G	GB	28
		458	693							0.69	958	S-924-60-G	GS6024G	GB	38	
		473	716	1074						0.82	1166	S-926-60-G	GS6026G	GB	50	

Note: Service Class I Torque Ratings (1.0 Service Factor)
 Service Class II Torque Ratings (≥ 1.4 Service Factor)
 Service Class III Torque Ratings (≥ 2.0 Service Factor)

Vertical motor below gearhead not recommended. Avoiding those positions where the high speed oil seal is immersed in oil, will provide greater security against high speed input seal wear.
 Replacement oil – 1 Qt P/N MJ0006A05SP (Klubersynth UH1-6-460)

Suffix: G = Left hand output facing input J = Right hand output facing input H = Double Output Shaft

Style F Basic

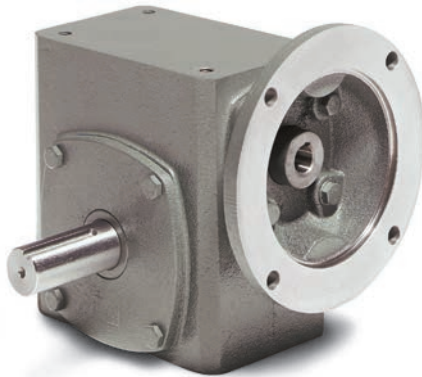

900 Series Dimensions Single Reduction Flanged Quill Type

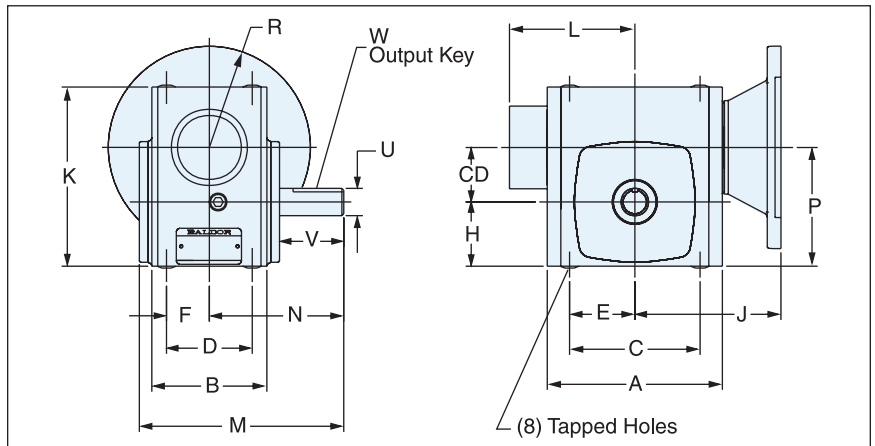

Size	C.D.	A	B	C	D	E	F	H	J		K	L	M	N	P	T	
									56C 140TC	180TC						Tap Size	Depth
913	1.33	4.25	2.88	3.25	2.00	1.63	1.00	1.72	3.94	—	4.65	—	6.03	4.00	3.05	0.312-18	0.62
915	1.54	5.13	3.69	4.19	2.75	2.10	1.38	1.91	4.50	—	5.38	—	6.72	4.31	3.45	0.312-18	0.62
918	1.75	5.56	3.69	4.19	2.75	2.09	1.38	2.06	4.69	—	5.75	—	6.78	4.31	3.81	0.312-18	0.62
921	2.06	6.06	3.81	5.00	2.88	2.50	1.44	2.28	5.07	—	6.38	—	7.22	4.69	4.34	0.375-16	0.75
921G	2.06	5.80	3.81	4.75	3.00	2.38	1.44	2.28	4.41	—	6.38	—	7.16	4.69	4.34	0.312-18	0.75
924	2.38	6.44	4.06	5.00	2.88	2.50	1.44	2.50	5.25	—	6.94	—	7.75	5.09	4.88	0.375-16	0.75
926	2.62	7.38	4.44	6.38	3.38	3.19	1.69	2.94	5.75	6.19	8.00	—	8.50	5.62	5.56	0.375-16	0.75
930	3.00	8.25	5.06	7.00	4.00	3.50	2.00	3.25	6.25	6.40	8.88	—	9.87	6.75	6.25	0.437-14	0.75
932	3.25	8.92	5.88	7.50	4.00	3.75	2.00	3.50	6.56	7.00	9.38	6.65	10.69	7.06	6.75	0.437-14	0.88
938	3.75	10.00	6.37	8.50	4.75	4.25	2.38	3.88	7.07	7.50	10.44	7.34	11.71	7.75	7.63	0.500-13	0.75

Size	Output Shaft		W-Key		Motor Size Available Per Size Any Ratio	Approximate Weight Lbs.	Approximate Oil Capacity oz.
	U +0.000 -0.001	V	Sq.	Lgth.			
913	0.625	2.19	0.188	1.000	B5, B7	13	6.5
915	0.750	2.06	0.188	1.000	B5	21	10.0
918	0.875	2.06	0.188	1.000	B5, B7	28	14.0
921 / 921G	1.000	2.38	0.250	1.250	B5, B7	34	17.5
924	1.125	2.66	0.250	1.250	B5, B7, B9	40	26.5
926	1.125	2.78	0.250	2.000	B5, B7, B9	54	32.0
930	1.250	3.64	0.250	2.250	B5, B7, B9	72	65.0
932	1.375	3.44	0.313	2.500	B5, B7, B9	87	67.0
938	1.625	3.81	0.375	2.750	B7, B9, B11	117	88.0

Rating Information Pages 11 - 13

Motor Information				
Worm Bore Size Designation	NEMA Design	Bore +0.002 -0.000	Key Way	R
B5	56C	0.625	0.187 x 0.093	3.31
B7	140TC/180C	0.875	0.187 x 0.093	3.31
B9	180TC/210C	1.125	0.250 x 0.125	4.63
B11	210TC/250UC	1.375	0.312 x 0.156	4.63

Assembly Types

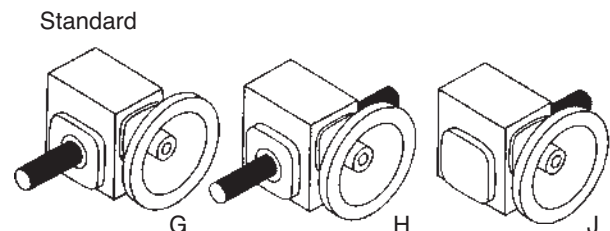

Stainless Steel Style SSF

Basic

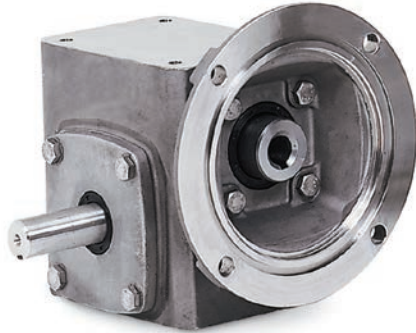

900 Series Dimensions Single Reduction Flanged Quill Type

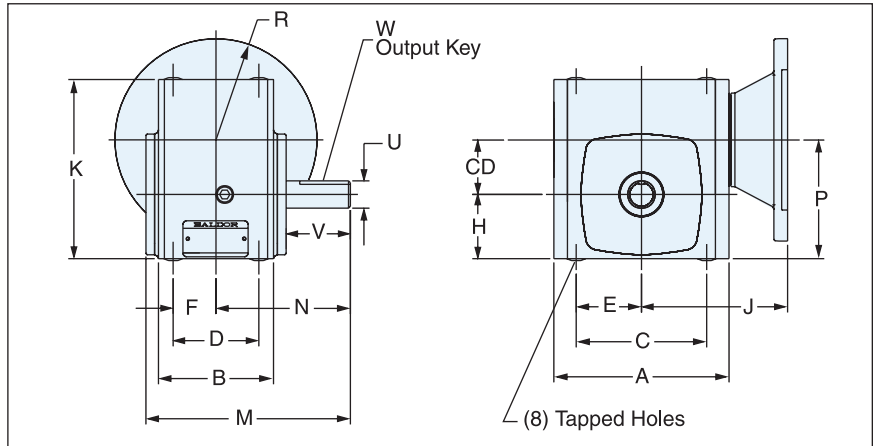

Size	C.D.	A	B	C	D	E	F	H	J		K	M	N	P	T	
									56C 140TC	180TC					Tap Size	Depth
918	1.75	5.62	3.69	4.19	2.75	2.09	1.38	2.06	4.69	—	5.75	6.78	4.31	3.81	0.312-18	0.59
921	2.06	6.13	3.83	5.00	2.88	2.50	1.44	2.28	5.07	—	6.38	7.22	4.69	4.34	0.375-16	0.59
926	2.62	7.45	4.44	6.38	3.38	3.19	1.69	2.94	5.79	6.03	8.00	8.51	5.63	5.56	0.375-16	0.69
932	3.25	9.00	5.88	7.50	4.00	3.75	2.00	3.50	6.57	6.81	9.38	10.69	7.06	6.75	0.937-14	0.88

Size	Output Shaft		W-Key		Motor Size Available Per Size Any Ratio	Approximate Weight Lbs.	Approximate Oil Capacity oz.
	U +0.000 -0.001	V	Sq.	Lgth.			
918	0.875	2.06	0.188	1.00	B5, B7	30	14.0
921	1.000	2.38	0.250	1.25	B5, B7	36	17.5
926	1.125	2.78	0.250	2.00	B5, B7, B9	56	32.0
932	1.375	3.44	0.313	2.50	B5, B7, B9	89	67.0

Rating Information Pages 11 - 13

Motor Information				
Worm Bore Size Designation	NEMA Design	Bore +0.002 -0.000	Key Way	R
B5	56C	0.625	0.187 x 0.093	3.31
B7	140TC/180C	0.875	0.187 x 0.093	3.31
B9	180TC/210C	1.125	0.250 x 0.125	4.63

Assembly Types

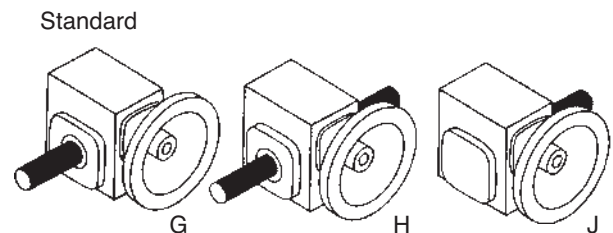

HFO
Reducer

900 Series
Single Reduction

900 Series
Double Reduction

Accessories

Ratio Multipliers

In-Line Helical (LH)

Universal Series
Single Reduction

Universal Series
Double Reduction

Engineering

Stainless Steel Style SSHF Hollow Output Shaft Basic

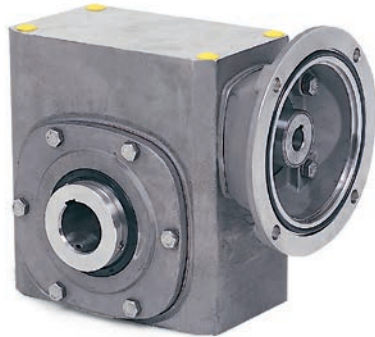

900 Series Dimensions Single Reduction Flanged Quill Type

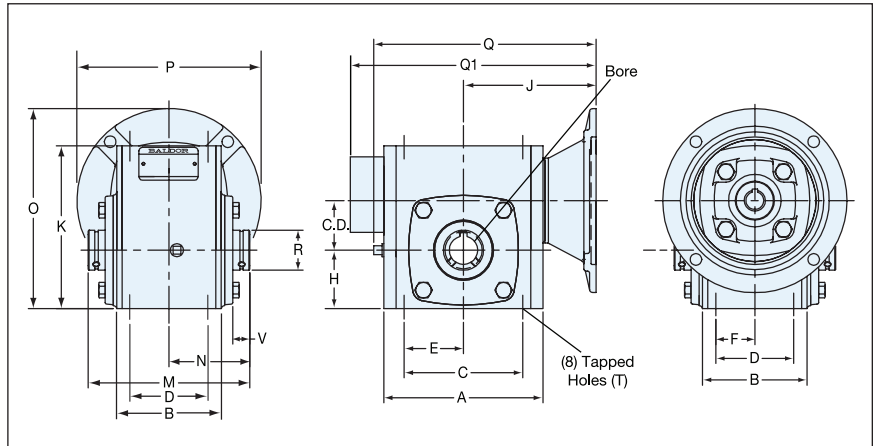

Size	C.D.	A	B	C	D	E	F	H	J		K	M	N	O	
									56C 140TC	180TC				56C 140TC	180TC
918	1.75	5.62	3.69	4.19	2.75	2.09	1.38	2.06	4.69	—	5.75	5.70	2.85	7.07	—
921	2.06	6.13	3.83	5.00	2.88	2.50	1.44	2.28	5.07	—	6.38	6.44	3.22	7.64	—
926	2.62	7.45	4.44	6.38	3.38	3.19	1.69	2.94	5.79	6.03	8.00	6.88	3.44	8.82	10.07
932	3.25	9.00	5.88	7.50	4.00	3.75	2.00	3.50	6.57	6.81	9.38	8.50	4.25	10.01	11.25

Size	Q		Q1		T		Output Shaft				W-Key		Motor Size Available Per Size Any Ratio	Approximate Weight Lbs.	Approximate Oil Capacity oz.
	56C 140TC	180TC	56C 140TC	180TC	Tap Size	Depth	R	Bore		V	Sq.	Length			
								Std.	Max.						
918	7.85	—	—	—	0.312-18	0.59	1.44	1.000	1.125	0.49	0.250	1.625	B5, B7	31	14.0
921	8.63	—	—	—	0.375-16	0.69	1.73	1.250	1.250	0.62	0.250	1.625	B5, B7	36	17.5
926	9.90	10.34	—	—	0.375-16	0.69	2.56	1.438	2.000	0.62	0.375	1.500	B5, B7, B9	59	32.0
932	—	—	13.42	13.74	0.437-14	0.88	2.56	1.938	—	0.87	0.500	2.25	B5, B7, B9	100	67.0

Ratings Information Pages 11 - 13

Motor Information				
Worm Bore Size Designation	NEMA Design	Bore +0.002 -0.000	Key Way	P
B5	56C	0.625	0.187 x 0.093	3.31
B7	140TC/180C	0.875	0.187 x 0.093	3.31
B9	180TC/210C	1.125	0.250 x 0.125	4.63

See Hollow Bore Bushing Kits, page 83

H50
Reducer

900 Series
Single Reduction

900 Series
Double Reduction

Accessories

Ratio Multiplier

In-Line Helical (LH)

Universal Series
Single Reduction

Universal Series
Double Reduction

Engineering

Stainless Steel Style SSHF

Hollow Output Shaft Position V/W



(Position W Shown)

Position V has flange on right hand side.

900 Series Dimensions Single Reduction Flanged Quill Type

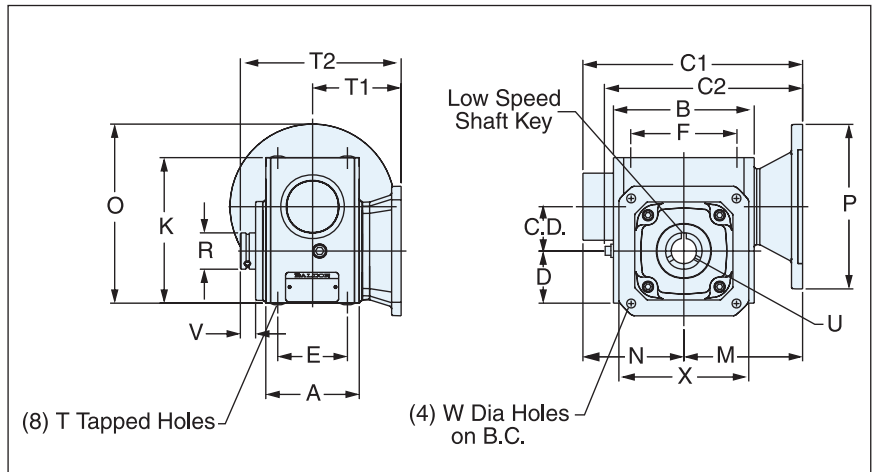

Size	C.D.	A	B	C1		C2		D	E	F	T Tap Size	Depth	M		O	
				56C 140TC	180TC	56C 140TC	180TC						56C 140TC	180TC		
918	1.75	3.69	5.62	—	—	7.85	—	2.06	2.75	4.19	0.312-18	0.59	4.69	—	7.07	—
921	2.06	3.81	6.13	—	—	8.63	—	2.28	2.88	5.00	0.375-16	0.69	5.07	—	7.64	—
926	2.62	4.44	7.45	—	—	9.90	9.88	2.94	3.38	6.38	0.375-16	0.69	5.79	6.03	8.82	10.07
932	3.25	5.88	9.00	13.42	13.74	—	—	3.50	4.00	7.50	0.437-14	0.88	6.57	6.81	10.01	11.25

Size	R	K	T ₁	T ₂	U +0.0015 -0	V	W	B.C.	X	Low Speed Shaft Key
918	1.44	5.75	3.50	6.35	1.000	0.49	.35	5.88	5.13	0.250 x 0.250 x 1.50
921	1.73	6.38	3.75	6.97	1.250	0.62	.41	6.50	5.75	0.250 x 0.250 x 1.50
926	2.56	8.00	4.06	7.50	1.437	0.62	.41	8.00	7.25	0.375 x 0.312 x 1.50
932	2.56	9.38	5.25	9.50	1.937	0.87	.57	10.00	9.00	0.500 x 0.375 x 2.25

Rating Information Pages 11 - 13

Size	Motor Size Available Per Size Any Ratio	Approximate Weight Lbs.	Approximate Oil Capacity oz.
918	B5, B7	23	14.0
921	B5, B7	29	17.5
926	B5, B7, B9	51	32.0
932	B5, B7, B9	82	67.0

Motor Information

Worm Bore Size Designation	NEMA Design	Bore +0.002 -0.000	Key Way	P
B5	56C	0.625	0.187 x 0.093	6.62
B7	140TC	0.875	0.187 x 0.093	6.62
B9	180TC	1.125	0.250 x 0.125	9.26

FRACTION SIZE	OUTPUT BORE CODE	SIZE				DECIMAL SIZE
		918	921	926	932	
1/2	008					0.500
5/8	010	O				0.625
3/4	012	O				0.750
1	100	S	O			1.000
1-1/8	102		O			1.125
1-3/16	103		O	O		1.188
1-1/4	104		S	O	O	1.250
1-3/8	106			O		1.375
1-7/16	107		O	S	O	1.438
1-1/2	108			O	O	1.500
1-15/16	115			O	S	1.938
2-1/8	202				O	2.125
2-3/16	203				O	2.188
Max Bore		1.125	1.625	2.000	2.188	

S = Standard Bore O = Optional Bore

Style F w/Horizontal Base

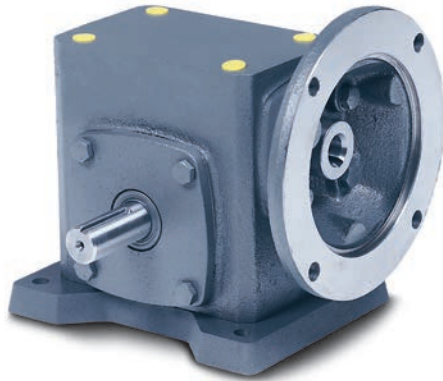

Shown in Position B

900 Series Dimensions Single Reduction Flanged Quill Type

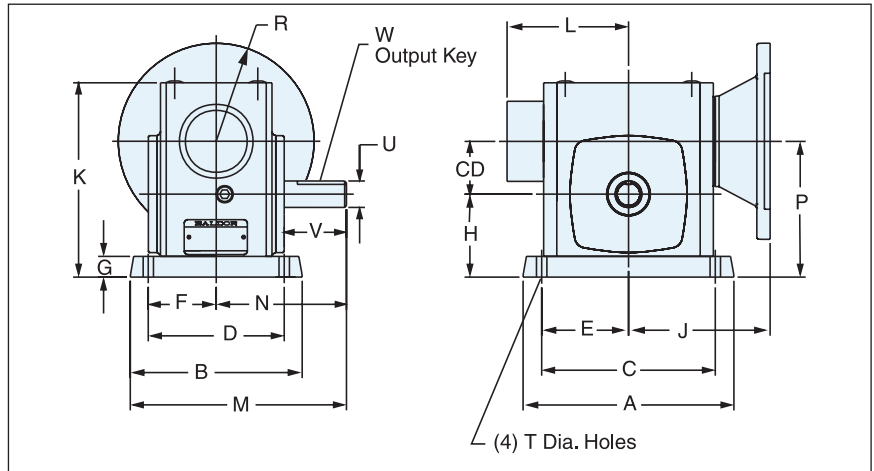

Size	C.D.	A	B	C	D	E	F	G	H	J		K	L Fan Guard	M	N	P	T
										56C 140TC	180TC						
913	1.33	5.38	4.19	4.38	3.31	2.19	1.66	0.53	2.25	3.94	—	5.18	—	6.09	4.00	3.58	0.343
915	1.54	6.44	5.44	5.25	4.31	2.63	2.16	0.69	2.60	4.50	—	6.07	—	7.16	4.31	4.14	0.406
918	1.75	7.00	5.69	5.75	4.50	2.88	2.25	0.69	XA2.75	4.69	—	6.44	—	7.16	4.31	4.50	0.406
921	2.06	7.75	5.94	6.38	4.69	3.19	2.34	0.72	3.00	5.07	—	7.09	—	7.66	4.69	5.06	0.468
924	2.38	8.50	6.19	7.06	4.88	3.53	2.44	0.75	3.25	5.25	—	7.69	—	8.19	5.09	5.63	0.468
926	2.62	9.63	6.66	8.00	5.25	4.00	2.63	0.75	3.69	5.75	6.19	8.75	—	8.96	5.63	6.31	0.531
930	3.00	10.21	7.54	8.44	5.88	4.22	2.94	0.69	4.00	6.25	6.40	9.63	—	10.52	6.75	7.00	0.468
932	3.25	11.19	7.66	9.50	6.12	4.75	3.06	0.88	4.38	6.56	7.00	10.25	6.65	10.89	7.06	7.63	0.531
938	3.75	12.13	8.66	10.38	7.00	5.19	3.50	0.94	4.82	7.07	7.50	11.82	7.34	11.25	7.75	8.57	0.593

Size	Output Shaft		W-Key		Motor Size Available Per Size Any Ratio	Approximate Weight Lbs.	Approximate Oil Capacity oz.
	U +0.000 -0.001	V	Sq.	Lgth.			
913	0.625	2.19	0.188	1.00	B5	14	6.5
915	0.750	2.06	0.188	1.00	B5, B7	20	10.0
918	0.875	2.06	0.188	1.00	B5, B7	23	14.0
921	1.000	2.38	0.250	1.25	B5, B7	30	17.5
924	1.125	2.66	0.250	1.25	B5, B7, B9	36	26.5
926	1.125	2.78	0.250	2.00	B5, B7, B9	50	32.0
930	1.250	3.64	0.250	2.25	B5, B7, B9	76	65.0
932	1.375	3.44	0.313	2.50	B5, B7, B9	97	67.0
938	1.625	3.81	0.375	2.75	B7, B9, B11	132	88.0

Rating Information Pages 11 - 13 Optional Bases Pages 80 - 81

Motor Information				
Worm Bore Size Designation	NEMA Design	Bore +0.002 -0.000	Key Way	R
B5	56C	0.625	0.187 x 0.093	3.31
B7	140TC/180C	0.875	0.187 x 0.093	3.31
B9	180TC/210C	1.125	0.250 x 0.125	4.63
B11	210TC/250UC	1.375	0.312 x 0.156	4.63

Assembly Types

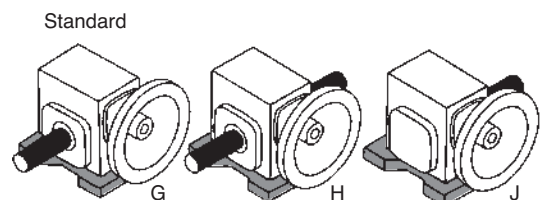

Style F
w/Vertical Base

900 Series Dimensions
Single Reduction Flanged Quill Type



Shown in Position E/F

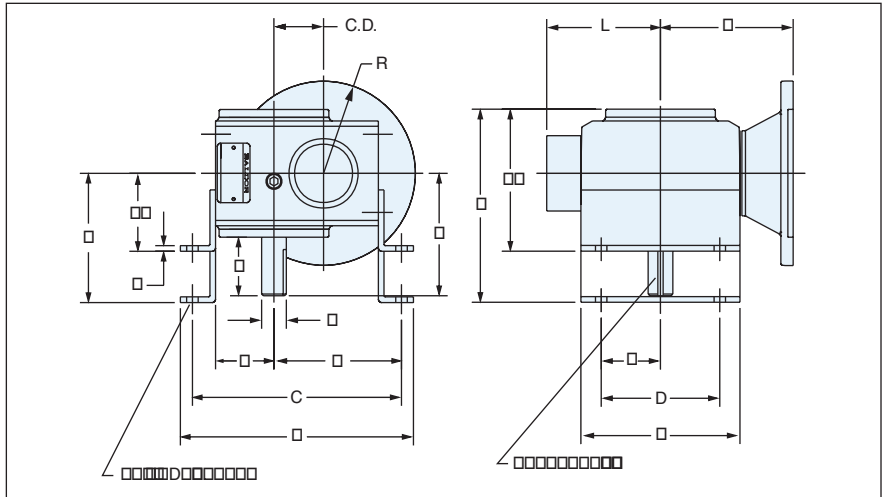

Size	C.D.	A	B	C	D	E	F	G	H	H ₁	J		K	K ₁	L FAN GUARD	N	P	T
											56C 140TC	180TC						
913	1.33	7.09	4.12	6.15	3.25	1.72	1.63	0.25	3.56	2.31	3.94	—	5.59	4.34	—	3.68	4.00	0.343
915	1.54	8.06	5.16	7.01	4.00	1.91	2.00	0.25	4.38	3.00	4.50	—	6.71	5.33	—	4.28	4.31	0.343
918	1.75	8.43	5.16	7.38	4.00	2.06	2.00	0.25	4.38	3.00	4.69	—	6.84	5.47	—	4.50	4.31	0.406
921	2.06	9.50	6.03	8.38	4.88	2.28	2.44	0.31	4.88	3.13	5.07	—	7.41	5.66	—	5.09	4.69	0.468
924	2.38	10.06	6.31	8.94	4.88	2.50	2.44	0.31	5.25	3.38	5.25	—	7.91	6.03	—	5.44	5.09	0.468
926	2.62	11.68	7.38	10.13	5.75	2.94	2.88	0.31	5.59	3.63	5.75	6.19	8.47	6.50	—	6.13	5.63	0.531
930	3.00	12.50	8.25	11.13	6.00	3.25	3.00	0.38	5.88	3.94	6.25	6.40	9.00	7.06	—	6.75	6.75	0.531
932	3.25	13.38	9.00	11.88	6.12	3.50	3.06	0.38	6.25	4.69	6.56	7.00	9.88	8.31	6.65	7.13	7.06	0.531
938	3.75	15.70	10.00	13.94	8.00	3.97	4.00	0.94	7.00	5.25	7.05	7.50	10.96	9.21	7.34	8.32	7.75	0.531

Size	Output Shaft		W-Key		Motor Size Available Per Size Any Ratio	Approximate Weight Lbs.	Approximate Oil Capacity oz.
	U +0.000 -0.001	V	Sq.	Lgth.			
913	0.625	2.19	0.188	1.00	B5	13	6.5
915	0.750	2.06	0.188	1.00	B5, B7	20	10.0
918	0.875	2.06	0.188	1.00	B5, B7	22	14.0
921	1.000	2.38	0.250	1.25	B5, B7	29	17.5
924	1.125	2.66	0.250	1.25	B5, B7, B9	34	26.5
926	1.125	2.78	0.250	2.00	B5, B7, B9	49	32.0
930	1.250	3.64	0.250	2.25	B5, B7, B9	74	65.0
932	1.375	3.44	0.313	2.50	B5, B7, B9	99	67.0
938	1.625	3.81	0.375	2.75	B7, B9, B11	135	88.0

Rating Information Pages 11 - 13 Optional Base Pages 80 - 81

Motor Information				
Worm Bore Size Designation	NEMA Design	Bore +0.002 -0.000	Key Way	R
B5	56C	0.625	0.187 x 0.093	3.31
B7	140TC/180C	0.875	0.187 x 0.093	3.31
B9	180TC/210C	1.125	0.250 x 0.125	4.63
B11	210TC/250UC	1.375	0.312 x 0.156	4.63

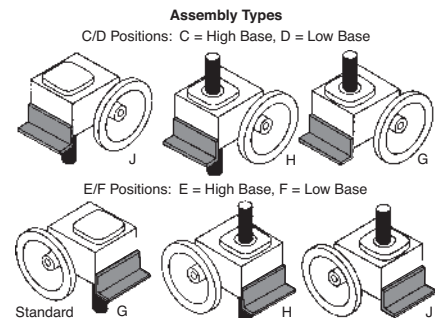

HFO Reducer
900 Series Single Reduction
900 Series Double Reduction
Accessories
Ratio Multipliers
In-Line Helical (LH)
Universal Series Single Reduction
Universal Series Double Reduction
Engineering

Style F w/J Mount



Shown in Position X

900 Series Dimensions Single Reduction Flanged Quill Type

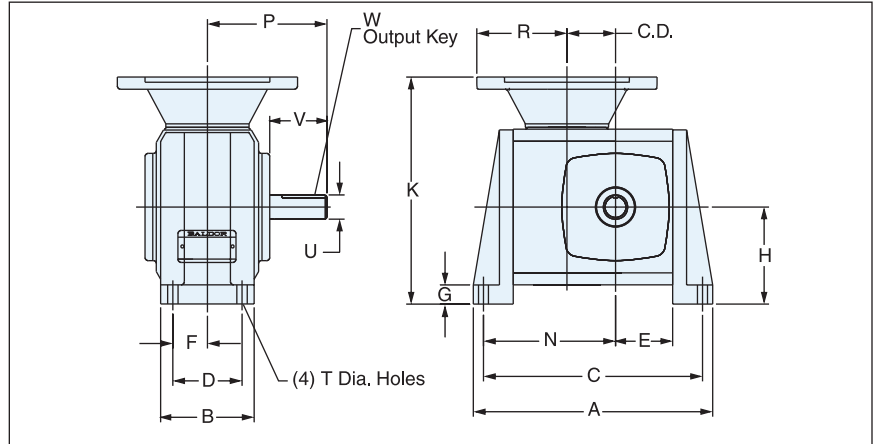

Size	C.D.	A	B	C	D	E	F	G	H	K		N	P	T
										56C 140TC	180TC			
913	1.33	7.27	2.88	6.41	2.00	1.72	1.00	0.53	2.94	6.88	—	3.81	4.00	0.34
915	1.54	8.26	3.38	7.26	2.50	1.91	1.25	0.69	3.50	8.00	—	4.41	4.31	0.41
918	1.75	8.63	3.38	7.63	2.50	2.06	1.25	0.69	3.50	8.19	—	4.63	4.31	0.41
921	2.06	9.76	3.75	8.62	2.62	2.28	1.31	0.72	3.94	9.01	—	5.21	4.69	0.47
924	2.38	10.32	4.06	9.19	2.88	2.50	1.44	0.75	4.06	9.31	—	5.56	5.09	0.47
926	2.62	11.76	4.44	10.38	3.12	2.94	1.56	0.75	4.75	10.50	10.94	6.25	5.63	0.53
932*	3.25	14.00	6.00	12.75	4.00	3.50	2.00	0.81	5.69	12.25	12.69	7.57	7.06	0.53

Size	Output Shaft		W-Key		Motor Size Available Per Size Any Ratio	Approximate Weight Lbs.	Approximate Oil Capacity oz.
	U +0.000 -0.001	V	Sq.	Lgth.			
913	0.625	2.19	0.188	1.00	B5	13	6.5
915	0.750	2.06	0.188	1.00	B5, B7	20	10.0
918	0.875	2.06	0.188	1.00	B5, B7	22	14.0
921	1.000	2.38	0.250	1.25	B5, B7	29	17.5
924	1.125	2.66	0.250	1.25	B5, B7, B9	34	26.5
926	1.125	2.78	0.250	2.00	B5, B7, B9	49	32.0
932*	1.375	3.44	0.313	2.50	B5, B7, B9	93	67.0

Rating Information Pages 11 - 13 Optional Base Pages 80 - 81
* 932J Base Part No. HA6622A07SP for use less fan. Unit must be derated 33%.

Motor Information				
Worm Bore Size Designation	NEMA Design	Bore +0.002 -0.000	Key Way	R
B5	56C	0.625	0.187 x 0.093	3.31
B7	140TC/180C	0.875	0.187 x 0.093	3.31
B9	180TC/210C	1.125	0.250 x 0.125	4.63

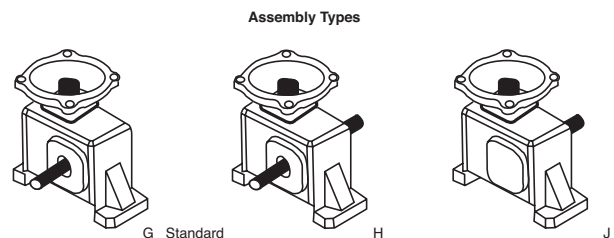

Style F

w/Output Flange

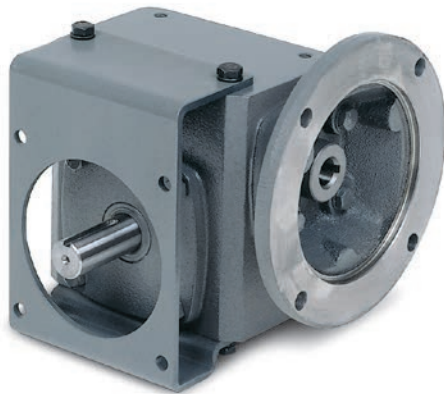

Shown in Position L

900 Series Dimensions Single Reduction Flanged Quill Type

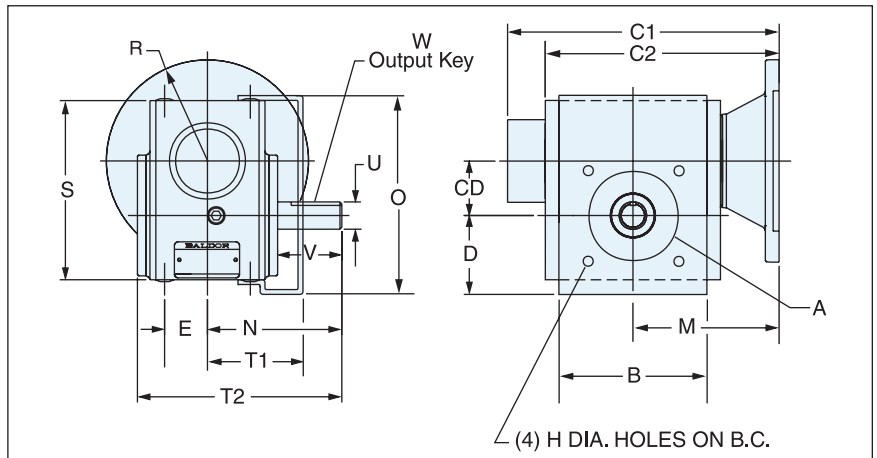

Size	C.D.	A	B	C1		C2		D	E	H	B.C.	M		N	O	S	T1	T2
				56C 140TC	180TC	56C 140TC	180TC					56C 140TC	180TC					
913	1.33	3.63	4.25	—	—	6.06	—	2.43	1.00	.344	5.00	3.94	—	4.00	5.56	4.65	3.00	6.03
915	1.54	3.63	4.75	—	—	7.06	—	2.53	1.38	.344	5.00	4.50	—	4.31	6.19	5.38	3.57	6.72
918	1.75	4.06	4.81	—	—	7.47	—	2.78	1.38	.344	5.87	4.69	—	4.31	6.66	5.75	3.51	6.78
921	2.06	4.50	5.75	—	—	8.10	—	3.14	1.44	.406	6.50	5.07	—	4.69	7.43	6.38	3.75	7.22
924	2.38	5.00	6.13	—	—	8.47	—	3.61	1.44	.406	7.50	5.25	—	5.09	8.24	6.94	3.72	7.75
926	2.62	6.00	7.18	—	—	9.44	9.88	3.94	1.69	.406	8.00	5.75	6.19	5.62	9.25	8.00	4.06	8.50
930	3.00	7.00	8.50	—	—	10.38	10.53	4.14	2.00	.406	9.00	6.25	6.40	6.75	10.02	8.88	4.50	9.87
932	3.25	7.00	8.50	13.21	13.65	11.02	11.11	4.75	2.00	.563	10.00	6.56	7.00	7.06	10.89	9.38	5.25	10.69
938	3.75	8.00	9.54	14.41	14.84	12.07	12.50	5.04	2.38	.563	11.50	7.07	7.50	7.75	11.85	10.44	5.46	11.71

Size	Output Shaft		W-Key		Motor Size Available Per Size Any Ratio	Approximate Weight Lbs.	Approximate Oil Capacity Oz.
	U +0.000 -0.001	V	Sq.	Lgth.			
913	0.625	2.19	0.188	1.00	B5	18	6.5
915	0.750	2.06	0.188	1.00	B5, B7	29	10.0
918	0.875	2.06	0.188	1.00	B5, B7	29	14.0
921	1.000	2.38	0.250	1.25	B5, B7	36	17.5
924	1.125	2.66	0.250	1.25	B5, B7, B9	43	26.5
926	1.125	2.78	0.250	2.00	B5, B7, B9	63	32.0
930	1.250	3.64	0.250	2.25	B5, B7, B9	90	65.0
932	1.375	3.44	0.313	2.50	B5, B7, B9	109	67.0
938	1.625	3.81	0.375	2.75	B5, B7, B11	140	88.0

Rating Information Pages 11 - 13

Motor Information				
Worm Bore Size Designation	NEMA Design	Bore +0.002 -0.000	Key Way	R
B5	56C	0.625	0.187 x 0.093	3.31
B7	140TC/180C	0.875	0.187 x 0.093	3.31
B9	180TC/210C	1.125	0.250 x 0.125	4.63
B11	210TC/250UC	1.375	0.312 x 0.156	4.63

H50
Reducer

900 Series
Single Reduction

900 Series
Double Reduction

Accessories

Ratio Multipliers

In-Line Helical (LH)

Universal Series
Single Reduction

Universal Series
Double Reduction

Engineering

Style F
w/Riser Block
and Horizontal Base



BRB

900 Series Dimensions
Single Reduction Flanged Quill Type

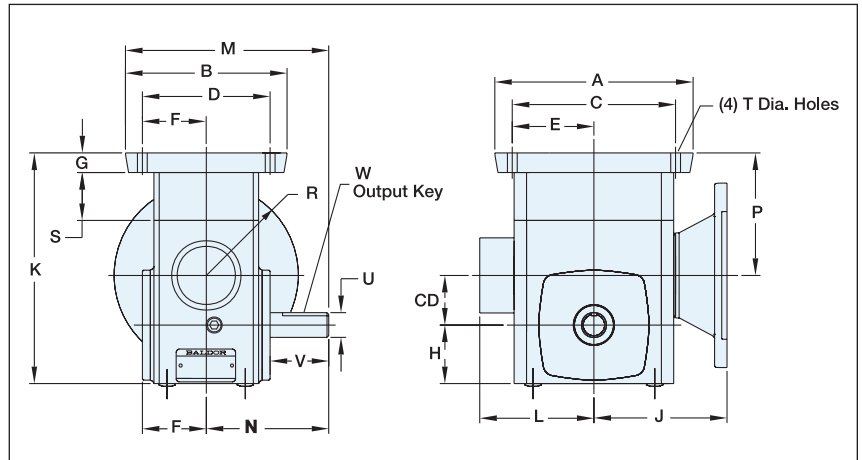

Size	C.D.	A	B	C	D	E	F	G	H	J		K	L Fan Guard	M	N	P	T	S	
										56C 140TC	180TC							56C 140TC	180TC 210TC
913	1.33	5.38	4.19	4.38	3.31	2.19	1.66	0.53	1.72	3.94	—	7.19	—	6.09	4.00	4.13	0.343	2.09	—
915	1.54	7.00	5.69	5.25	4.31	2.88	2.25	0.69	1.91	4.50	—	7.76	—	7.16	4.31	4.31	0.406	1.60	—
918	1.75	7.00	5.69	5.75	4.50	2.88	2.25	0.69	2.06	4.69	—	8.13	—	7.16	4.31	4.32	0.406	1.69	—
921	2.06	7.75	5.94	6.38	4.69	3.19	2.34	0.72	2.28	5.07	—	8.63	—	7.66	4.69	4.29	0.468	1.53	—
924	2.38	8.50	6.19	7.06	4.88	3.53	2.44	0.75	2.50	5.25	—	9.19	—	8.19	5.09	4.31	0.468	1.50	3.00
926	2.62	9.63	6.66	8.00	5.25	4.00	2.63	0.75	2.94	5.75	6.19	10.00	—	8.96	5.63	4.45	0.531	1.25	2.52
930	3.00	10.21	7.54	8.44	5.88	4.22	2.94	0.69	3.25	6.25	6.40	11.76	—	10.52	6.75	5.50	0.468	1.06	2.13
932	3.25	11.19	7.66	9.50	6.12	4.75	3.06	0.88	3.50	6.56	7.00	11.44	6.65	10.89	7.06	4.69	0.531	1.18	2.37

Size	Output Shaft		W-Key		Motor Size Available Per Size Any Ratio	Approximate Weight Lbs.	Approximate Oil Capacity Oz.
	U +0.000 -0.001	V	Sq.	Lgth.			
913	0.625	2.19	0.188	1.00	B5	14	6.5
915	0.750	2.06	0.188	1.00	B5, B7	20	10.0
918	0.875	2.06	0.188	1.00	B5, B7	23	14.0
921	1.000	2.38	0.250	1.25	B5, B7	30	17.5
924	1.125	2.66	0.250	1.25	B5, B7, B9	36	26.5
926	1.125	2.78	0.250	2.00	B5, B7, B9	50	32.0
930	1.250	3.64	0.250	2.25	B5, B7, B9	74	65.0
932	1.375	3.44	0.313	2.50	B5, B7, B9	85	67.0
938	1.625	3.81	0.375	2.75	B7, B9, B11	126	88.0

Rating Information Pages 11 - 13 Optional Base Pages 80 - 81

Motor Information				
Worm Bore Size Designation	NEMA Design	Bore +0.002 -0.000	Key Way	R
B5	56C	0.625	0.187 x 0.093	3.31
B7	140TC/180C	0.875	0.187 x 0.093	3.31
B9	180TC/210C	1.125	0.250 x 0.125	4.63
B11	210TC/250UC	1.375	0.312 x 0.156	4.63

Style S
Basic

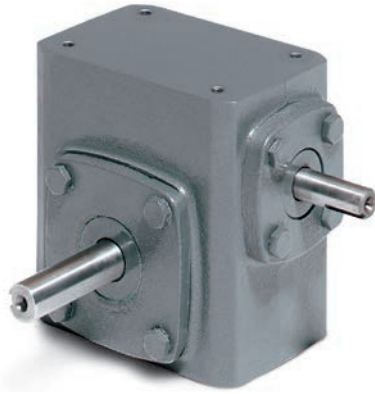

900 Series Dimensions
Single Reduction Solid Worm Type

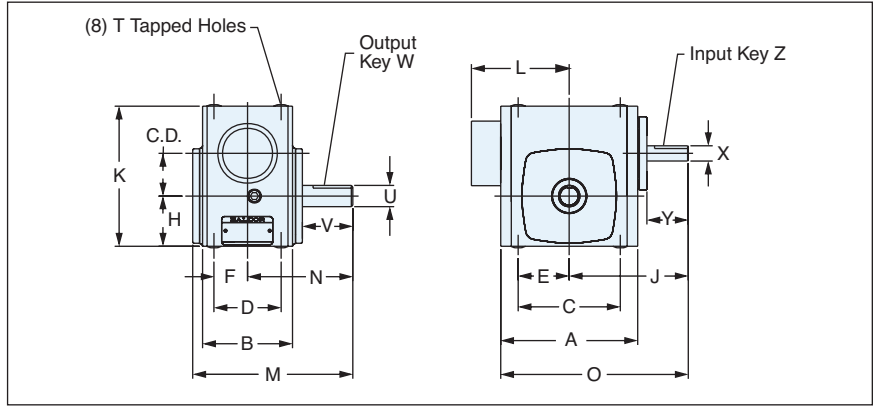

Size	C.D.	A	B	C	D	E	F	H	J	K	L Fan Guard	M	N	O	T	
															Tap Size	Depth
913	1.33	4.25	2.88	3.25	2.00	1.63	1.00	1.72	3.91	4.65	—	6.03	4.00	6.03	0.312-18	0.62
915	1.54	5.13	3.69	4.19	2.75	2.10	1.38	1.91	4.69	5.38	—	6.72	4.31	7.25	0.312-18	0.62
918	1.75	5.56	3.69	4.19	2.75	2.09	1.38	2.06	4.88	5.75	—	6.78	4.31	7.66	0.312-18	0.62
921	2.06	6.06	3.81	5.00	2.88	2.50	1.44	2.28	5.13	6.38	—	7.22	4.69	8.16	0.375-16	0.75
924	2.38	6.44	4.06	5.00	2.88	2.50	1.44	2.50	5.75	6.94	—	7.75	5.09	8.97	0.375-16	0.75
926	2.62	7.38	4.44	6.38	3.38	3.19	1.69	2.94	6.31	8.00	—	8.50	5.62	10.00	0.375-16	0.75
930	3.00	8.25	5.06	7.00	4.00	3.50	2.00	3.25	6.82	8.88	—	9.87	6.75	10.95	0.437-14	0.88
932	3.25	8.92	5.88	7.50	4.00	3.75	2.00	3.50	7.44	9.38	6.65	10.69	7.06	11.90	0.437-14	0.88
938	3.75	10.00	6.37	8.50	4.75	4.25	2.38	3.88	8.38	10.44	7.34	11.71	7.75	15.72	0.500-13	0.75

Size	Output Shaft				Input Shaft				Approximate Weight Lbs.	Approximate Oil Capacity Oz.
	U +0.000 -0.001	V	W-Key		X +0.000 -0.001	Y	Z-Key			
			Sq.	Lgth.			Sq.	Lgth.		
913	0.625	2.19	0.187	1.00	0.500	1.34	0.125	0.62	11	6.5
915	0.750	2.06	0.187	1.00	0.625	1.69	0.187	1.25	20	10.0
918	0.875	2.06	0.187	1.00	0.625	1.69	0.187	1.25	25	14.0
921	1.000	2.38	0.250	1.25	0.625	1.69	0.187	1.25	30	17.5
924	1.125	2.66	0.250	1.25	0.750	2.12	0.187	1.25	30	26.5
926	1.125	2.78	0.250	2.00	0.750	2.19	0.187	1.38	43	32.0
930	1.250	3.64	0.250	2.25	0.875	2.25	0.187	1.50	59	65.0
932	1.375	3.44	0.312	2.50	0.875	2.50	0.187	1.62	71	67.0
938	1.625	3.81	0.375	2.75	1.000	2.91	0.250	1.50	106	88.0

Rating Information Pages 11 - 13

Assembly Types

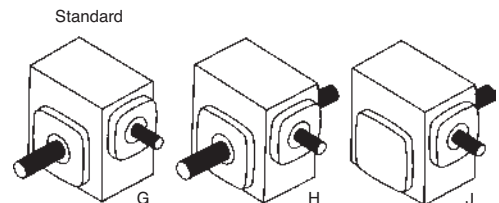

Style S w/Horizontal Base

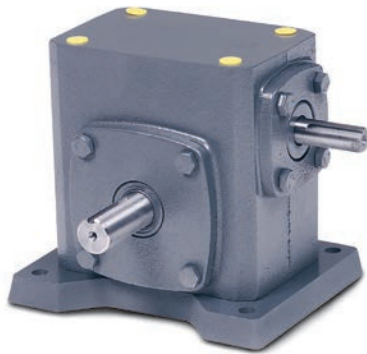

Shown in Position B

900 Series Dimensions Single Reduction Solid Worm Type

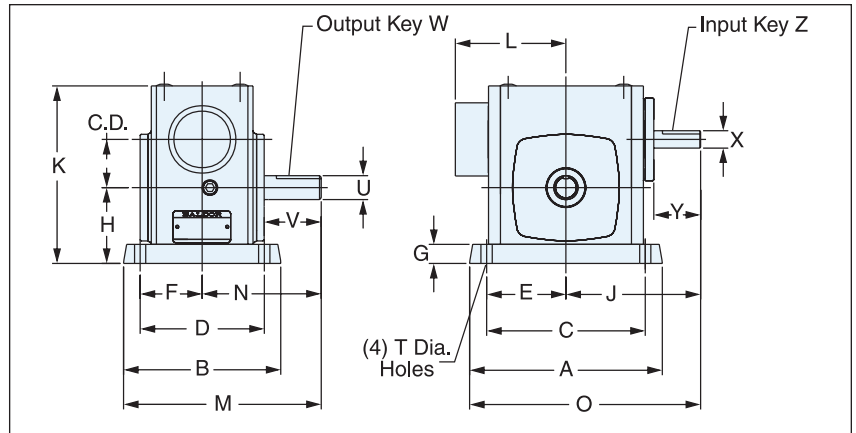

Size	C.D.	A	B	C	D	E	F	G	H	J	K	L Fan Guard	M	N	O	T
913	1.33	5.38	4.19	4.38	3.31	2.19	1.66	0.53	2.25	3.91	5.18	—	6.09	4.00	6.59	0.343
915	1.54	7.00	5.69	5.25	4.31	2.88	2.25	0.69	2.60	4.69	6.07	—	7.16	4.31	8.19	0.343
918	1.75	7.00	5.69	5.75	4.50	2.88	2.25	0.69	2.75	4.88	6.44	—	7.16	4.31	8.38	0.406
921	2.06	7.75	5.94	6.38	4.69	3.19	2.34	0.72	3.00	5.13	7.09	—	7.66	4.69	9.00	0.468
924	2.38	8.50	6.19	7.06	4.88	3.53	2.44	0.75	3.25	5.75	7.69	—	8.19	5.09	10.00	0.468
926	2.62	9.62	6.66	8.00	5.25	4.00	2.63	0.75	3.69	6.31	8.75	—	8.96	5.63	11.12	0.531
930	3.00	10.21	7.54	8.44	5.88	4.22	2.94	0.69	4.00	6.82	9.63	—	10.52	6.75	11.93	0.468
932	3.25	11.19	7.66	9.50	6.12	4.75	3.06	0.88	4.38	7.44	10.25	6.65	10.89	7.06	13.03	0.531
938	3.75	12.13	8.66	10.38	7.00	5.19	3.50	0.94	4.82	8.38	11.82	7.34	11.25	7.75	14.45	0.531

Size	Output Shaft				Input Shaft				Approximate Weight Lbs.	Approximate Oil Capacity Oz.
	U +0.000 -0.001	V	W-Key		X +0.000 -0.001	Y	Z-Key			
			Sq.	Lgth.			Sq.	Lgth.		
913	0.625	2.19	0.187	1.00	0.500	1.34	0.125	0.62	12	6.5
915	0.750	2.06	0.187	1.00	0.625	1.69	0.187	1.25	20	10.0
918	0.875	2.06	0.187	1.00	0.625	1.69	0.187	1.25	21	14.0
921	1.000	2.38	0.250	1.25	0.625	1.69	0.187	1.25	28	17.5
924	1.125	2.66	0.250	1.25	0.750	2.12	0.187	1.25	33	26.5
926	1.125	2.78	0.250	2.00	0.750	2.19	0.187	1.38	47	32.0
930	1.250	3.64	0.250	2.25	0.875	2.25	0.187	1.50	67	65.0
932	1.375	3.44	0.312	2.50	0.875	2.50	0.187	1.62	80	67.0
938	1.625	3.81	0.375	2.75	1.000	2.91	0.250	1.50	121	88.0

Rating Information Pages 11 - 13 Optional Base Pages 80 - 81

Assembly Types

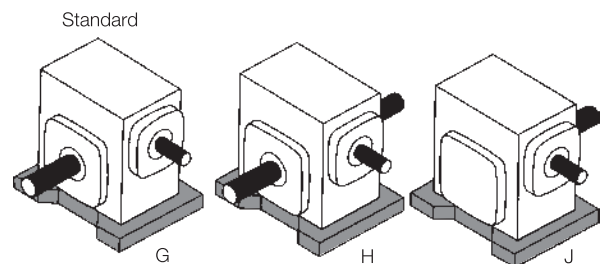

Style S

w/Horizontal Base



Shown in Position A

900 Series Dimensions Single Reduction Solid Worm Type

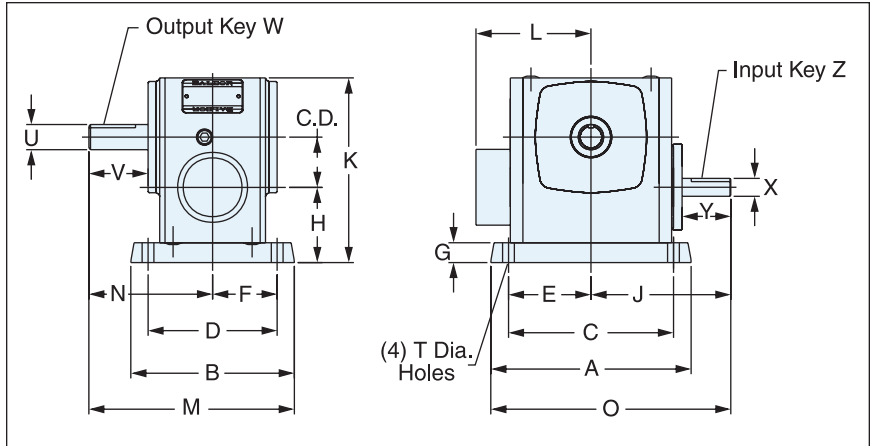

Size	C.D.	A	B	C	D	E	F	G	H	J	K	L Fan Guard	M	N	O	T
913	1.33	5.38	4.19	4.38	3.31	2.19	1.66	0.53	2.25	3.91	5.18	—	6.09	4.00	6.59	0.343
915	1.54	7.00	5.69	5.25	4.31	2.88	2.25	0.69	2.62	4.69	6.07	—	7.16	4.31	8.19	0.343
918	1.75	7.00	5.69	5.75	4.50	2.88	2.25	0.69	2.75	4.88	6.44	—	7.16	4.31	8.38	0.406
921	2.06	7.75	5.94	6.38	4.69	3.19	2.34	0.72	3.00	5.13	7.09	—	7.66	4.69	9.00	0.468
924	2.38	8.50	6.19	7.06	4.88	3.53	2.44	0.75	3.25	5.75	7.69	—	8.19	5.09	10.00	0.468
926	2.62	9.62	6.66	8.00	5.25	4.00	2.63	0.75	3.69	6.31	8.75	—	8.96	5.63	11.12	0.531
930	3.00	10.21	7.54	8.44	5.88	4.22	2.94	0.69	3.38	6.82	9.63	—	10.52	6.75	11.93	0.468
932	3.25	11.19	7.66	9.50	6.12	4.75	3.06	0.88	4.38	7.44	10.25	6.65	10.89	7.06	13.03	0.531
938	3.75	12.13	8.66	10.38	7.00	5.19	3.50	0.94	4.82	8.38	11.82	7.34	11.25	7.75	14.45	0.531

Size	Output Shaft				Input Shaft				Approximate Weight Lbs.	Approximate Oil Capacity Oz.
	U +0.000 -0.001	V	W-Key		X +0.000 -0.001	Y	Z-Key			
			Sq.	Lgth.			Sq.	Lgth.		
913	0.625	2.19	0.187	1.00	0.500	1.34	0.125	0.62	12	6.5
915	0.750	2.06	0.187	1.00	0.625	1.69	0.187	1.25	20	10.0
918	0.875	2.06	0.187	1.00	0.625	1.69	0.187	1.25	21	14.0
921	1.000	2.38	0.250	1.25	0.625	1.69	0.187	1.25	28	17.5
924	1.125	2.66	0.250	1.25	0.750	2.12	0.187	1.25	33	26.5
926	1.125	2.78	0.250	2.00	0.750	2.19	0.187	1.38	47	32.0
930	1.250	3.64	0.250	2.25	0.875	2.25	0.187	1.50	67	65.0
932	1.375	3.44	0.312	2.50	0.875	2.50	0.187	1.62	80	67.0
938	1.625	3.81	0.375	2.75	1.000	2.91	0.250	1.50	121	88.0

Rating Information Pages 11 - 13 Optional Bases Pages 80 - 81

Assembly T Types

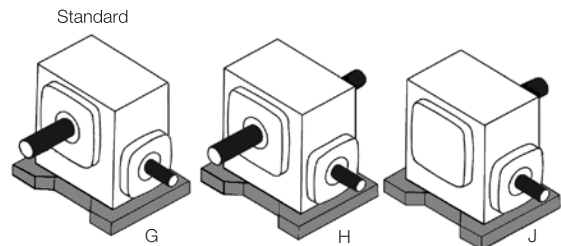

HFO Reducer

900 Series Single Reduction

900 Series Double Reduction

Accessories

Ratio Multipliers

In-Line Helical (LH)

Universal Series Single Reduction

Universal Series Double Reduction

Engineering

Style S
w/Vertical Base



Shown in Position E/F

900 Series Dimensions
Single Reduction Solid Worm Type

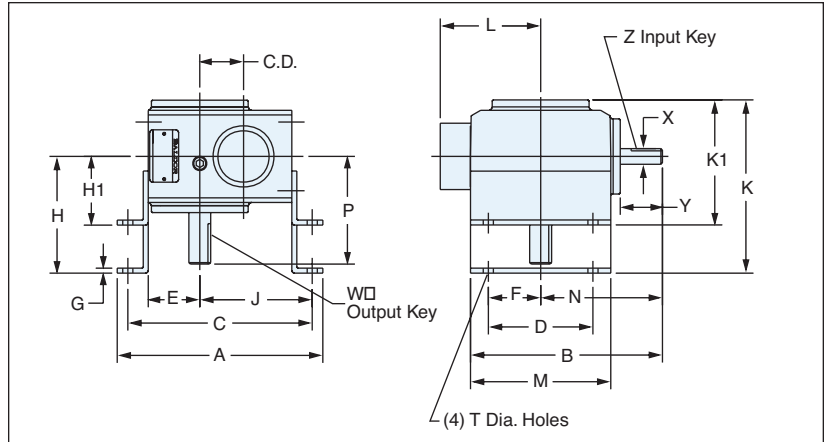

Size	C.D.	A	B	C	D	E	F	G	H	H1	J	K	K ₁	L Fan Guard	M	N	P	T
913	1.33	7.09	4.12	6.15	3.25	1.72	1.63	0.25	3.56	2.31	3.68	5.59	4.34	—	5.97	3.91	4.00	0.343
915	1.54	8.06	5.16	7.01	4.00	1.91	2.00	0.25	4.38	3.00	4.28	6.71	5.33	—	7.25	4.69	4.31	0.343
918	1.75	8.43	5.16	7.38	4.00	2.06	2.00	0.25	4.38	3.00	4.50	6.84	5.47	—	7.46	4.88	4.31	0.406
921	2.06	9.50	6.03	8.38	4.88	2.28	2.44	0.31	4.88	3.13	5.09	7.41	5.66	—	8.14	5.13	4.69	0.468
924	2.38	10.06	6.31	8.94	4.88	2.50	2.44	0.31	5.25	3.38	5.44	7.91	6.03	—	8.91	5.75	5.09	0.468
926	2.62	11.68	7.38	10.13	5.75	2.94	2.88	0.31	5.59	3.63	6.13	8.47	6.50	—	10.00	6.31	5.63	0.531
930	3.00	12.50	8.25	11.13	6.00	3.25	3.00	0.38	5.88	3.94	6.75	9.00	7.06	—	10.88	6.82	6.75	0.531
932	3.25	13.38	9.00	11.88	6.12	3.50	3.06	0.38	6.25	4.69	7.13	9.88	8.31	6.65	11.94	7.44	7.06	0.531
938	3.75	15.70	10.00	13.94	8.00	3.97	4.00	0.94	7.00	5.25	8.32	10.96	9.21	7.34	13.38	8.38	7.75	0.531

Size	Output Shaft				Input Shaft				Approximate Weight Lbs.	Approximate Oil Capacity Oz.
	U +0.000 -0.001	V	W-Key		X +0.000 -0.001	Y	Z-Key			
			Sq.	Lgth.			Sq.	Lgth.		
913	0.625	2.19	0.187	1.00	0.500	1.34	0.125	0.62	13	6.5
915	0.750	2.06	0.187	1.00	0.625	1.69	0.187	1.25	20	10.0
918	0.875	2.06	0.187	1.00	0.625	1.69	0.187	1.25	22	14.0
921	1.000	2.38	0.250	1.25	0.625	1.69	0.187	1.25	29	17.5
924	1.125	2.66	0.250	1.25	0.750	2.12	0.187	1.25	34	26.5
926	1.125	2.78	0.250	2.00	0.750	2.19	0.187	1.38	49	32.0
930	1.250	3.64	0.250	2.25	0.875	2.25	0.187	1.50	67	65.0
932	1.375	3.44	0.312	2.50	0.875	2.50	0.187	1.62	82	67.0
938	1.625	3.81	0.375	2.75	1.000	2.91	0.250	1.50	124	88.0

Rating Information Pages 11 - 13 Optional Base Pages 80 - 81

Assembly Types

C/D Positions: C = High Base, D = Low Base

E/F Positions: E = High Base, F = Low Base

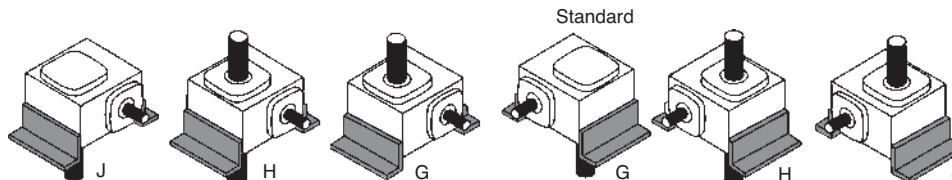

Style S
w/J Mount

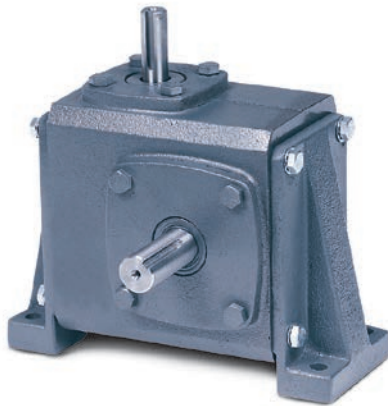

Shown in Position X

900 Series Dimensions
Single Reduction Solid Worm Type

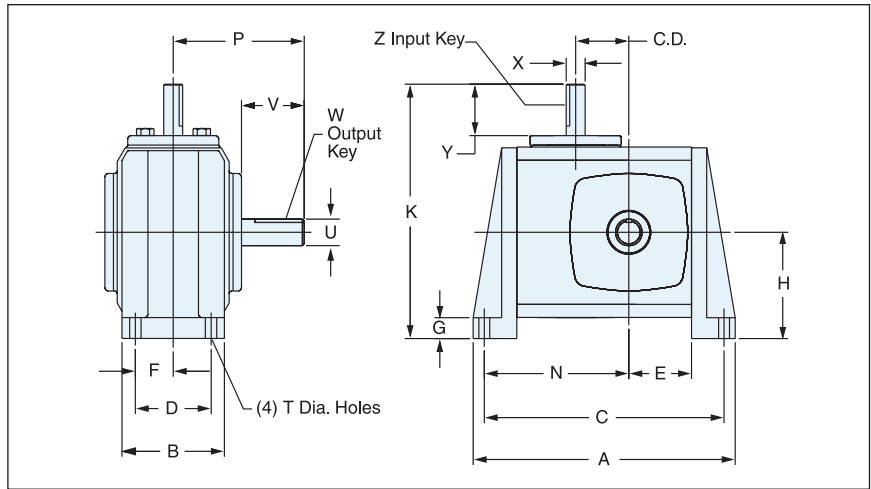

Size	C.D.	A	B	C	D	E	F	G	H	K	N	P	T
913	1.33	7.27	2.88	6.41	2.00	1.72	1.00	0.53	2.94	6.85	3.81	4.00	0.34
915	1.54	8.26	3.38	7.26	2.50	1.91	1.25	0.69	3.50	8.19	4.41	4.31	0.41
918	1.75	8.63	3.38	7.63	2.50	2.06	1.25	0.69	3.50	8.38	4.63	4.31	0.41
921	2.06	9.76	3.75	8.62	2.62	2.28	1.31	0.72	3.94	9.07	5.21	4.69	0.47
924	2.38	10.32	4.06	9.19	2.88	2.50	1.44	0.75	4.06	9.81	5.56	5.09	0.47
926	2.62	11.76	4.44	10.38	3.12	2.94	1.56	0.75	4.75	11.06	6.25	5.63	0.53
930	3.00	12.64	5.06	11.38	3.88	3.25	1.94	0.75	5.62	12.44	6.88	6.75	0.53
932*	3.25	14.00	6.00	12.75	4.00	3.50	2.00	0.81	5.69	13.13	7.57	7.06	0.53

Size	Output Shaft				Input Shaft				Approximate Weight Lbs.	Approximate Oil Capacity Oz.
	U +0.000 -0.001	V	W-Key		X +0.000 -0.001	Y	Z-Key			
			Sq.	Lgth.			Sq.	Lgth.		
913	0.625	2.19	0.187	1.00	0.500	1.34	0.125	0.62	13	6.5
915	0.750	2.06	0.187	1.00	0.625	1.69	0.187	1.25	20	10.0
918	0.875	2.06	0.187	1.00	0.625	1.69	0.187	1.25	22	14.0
921	1.000	2.38	0.250	1.25	0.625	1.69	0.187	1.25	29	17.5
924	1.125	2.66	0.250	1.25	0.750	2.12	0.187	1.25	34	26.5
926	1.125	2.78	0.250	2.00	0.750	2.19	0.187	1.38	49	32.0
930	1.250	3.64	0.250	2.25	0.875	2.25	0.187	1.50	67	65.0
932	1.375	3.44	0.312	2.50	0.875	2.50	0.187	1.62	82	67.0

Rating Information Pages 11 - 13 Optional Base Pages 80 - 81
*932J base Part No. HA6622A07SP for use less fan. Unit must be derated 33%.

Assembly Types

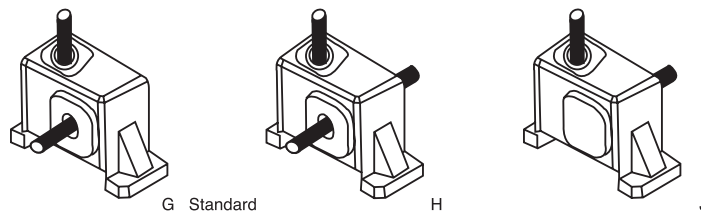

H50 Reducer

900 Series Single Reduction

900 Series Double Reduction

Accessories

Ratio Multipliers

In-Line Helical (LH)

Universal Series Single Reduction

Universal Series Double Reduction

Engineering

Style S w/Output Flange

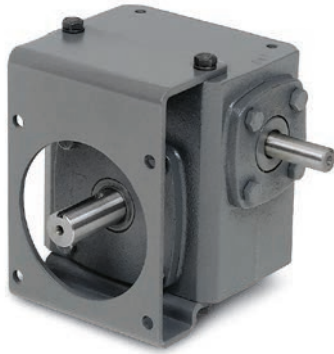

Shown in Position L

900 Series Dimensions Single Reduction Solid Worm Type

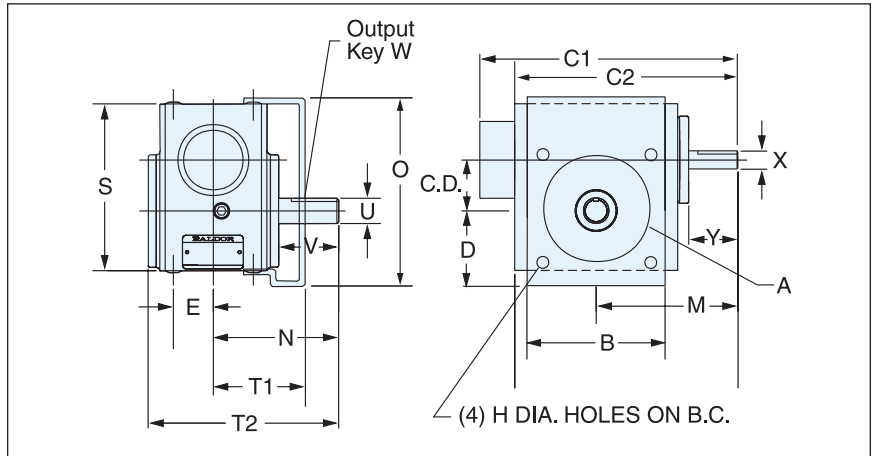

Size	C.D.	A	B	C1	C2	D	E	H	B.C.	M	N	O	S	T ₁	T ₂
913	1.33	3.63	4.25	—	6.03	2.43	1.00	.344	5.00	3.91	4.00	5.56	4.65	3.00	6.03
915	1.54	3.63	4.75	—	7.25	2.53	1.38	.344	5.00	4.69	4.31	6.19	5.38	3.57	6.72
918	1.75	4.06	4.81	—	7.66	2.78	1.38	.344	5.87	4.88	4.31	6.66	5.75	3.51	6.78
921	2.06	4.50	5.75	—	8.16	3.14	1.44	.406	6.50	5.13	4.69	7.43	6.38	3.75	7.22
924	2.38	5.00	6.13	—	8.97	3.61	1.44	.406	7.50	5.75	5.09	8.24	6.94	3.72	7.75
926	2.62	6.00	7.18	—	10.00	3.94	1.69	.406	8.00	6.31	5.62	9.25	8.00	4.06	8.50
930	3.00	7.00	8.50	—	10.95	4.14	2.00	.406	9.00	6.82	6.75	10.02	8.88	4.50	9.87
932	3.25	7.00	8.50	14.09	11.90	4.75	2.00	.563	10.00	7.44	7.06	10.89	9.38	5.25	10.69
938	3.75	8.00	9.54	15.72	15.72	5.04	2.38	.563	11.50	8.38	7.75	11.85	10.44	5.46	11.71

Size	Output Shaft				Input Shaft				Approximate Weight Lbs.	Approximate Oil Capacity Oz.
	U +0.000 -0.001xz	V	W-Key		X +0.000 -0.001	Y	Z-Key			
			Sq.	Lgth.			Sq.	Lgth.		
913	0.625	2.19	0.187	1.00	0.500	1.34	0.125	0.62	14	6.5
915	0.750	2.06	0.187	1.00	0.625	1.69	0.187	1.25	23	10.0
918	0.875	2.06	0.187	1.00	0.625	1.69	0.187	1.25	23	14.0
921	1.000	2.38	0.250	1.25	0.625	1.69	0.187	1.25	30	17.5
924	1.125	2.66	0.250	1.25	0.750	2.12	0.187	1.25	35	26.5
926	1.125	2.78	0.250	2.00	0.750	2.19	0.187	1.38	51	32.0
930	1.250	3.64	0.250	2.25	0.875	2.25	0.187	1.50	67	65.0
932	1.375	3.44	0.312	2.50	0.875	2.50	0.187	1.62	98	67.0
938	1.625	3.81	0.375	2.75	1.000	2.91	0.250	1.50	119	88.0

Rating Information Pages 11 - 13

Style LF Basic

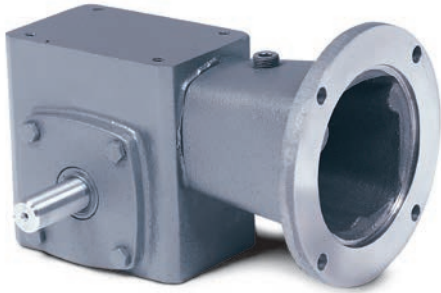

900 Series Dimensions Single Reduction Flanged Coupling Type

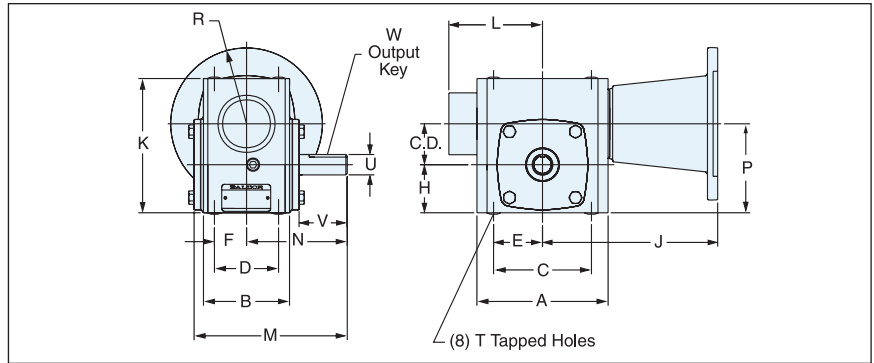

Size	C.D.	A	B	C	D	E	F	H	J		K	L Fan Guard	M	N	P
									56C 140TC	180TC 210TC					
913	1.33	4.25	2.88	3.25	2.00	1.63	1.00	1.72	6.54	—	4.65	—	6.03	4.00	3.05
915	1.54	5.13	3.69	4.19	2.75	2.10	1.38	1.91	7.31	—	5.38	—	6.72	4.31	3.45
918	1.75	5.56	3.69	4.19	2.75	2.09	1.38	2.06	7.50	—	5.75	—	6.78	4.31	3.81
921	2.06	6.06	3.81	5.00	2.88	2.50	1.44	2.28	7.75	—	6.38	—	7.22	4.69	4.34
924	2.38	6.44	4.06	5.00	2.88	2.50	1.44	2.50	7.94	—	6.94	—	7.75	5.09	4.88
926	2.62	7.38	4.44	6.38	3.38	3.19	1.69	2.94	9.15	9.96	8.00	—	8.50	5.62	5.56
930	3.00	8.25	5.06	7.00	4.00	3.50	2.00	3.25	9.87	10.31	8.88	—	9.87	6.75	6.25
932	3.25	8.92	5.88	7.50	4.00	3.75	2.00	3.50	10.28	11.04	11.04	6.65	10.69	7.06	6.75
938	3.75	10.00	6.37	8.50	4.75	4.25	2.38	3.88	11.25	11.94	10.88	7.34	11.71	7.75	7.63

Size	T		Output Shaft				Motor Size Available Per Size Any Ratio	Approximate Weight Lbs.	Approximate Oil Capacity oz.
	Tap Size	Depth	U +0.000 -0.001	V	W-Key				
					Sq.	Lgth.			
913	0.312-18	0.62	0.625	2.19	0.187	1.00	B5, B7	18	6.5
915	0.312-18	0.62	0.750	2.06	0.187	1.00	B5, B7	24	10.0
918	0.312-18	0.62	0.875	2.06	0.187	1.00	B5, B7	26	14.0
921	0.375-16	0.75	1.000	2.38	0.250	1.25	B5, B7	40	17.5
924	0.375-16	0.75	1.125	2.66	0.250	1.25	B5, B7	47	26.5
926	0.375-16	0.75	1.125	2.78	0.250	2.00	B5, B7, B9	52	32.0
930	0.437-14	0.88	1.250	3.64	0.250	2.25	B5, B7, B9	72	65.0
932	0.437-14	0.88	1.375	3.44	0.312	2.50	B5, B7, B9	100	67.0
938	0.500-13	0.75	1.625	3.81	0.375	2.75	B7, B9, B11	118	88.0

Rating Information Pages 11 - 13

Motor Information				
Worm Bore Size Designation	NEMA Design	Bore +0.002 -0.000	Key Way	R
B5	56C	0.625	0.187 x 0.093	3.31
B7	140TC/180C	0.875	0.187 x 0.093	3.31
B9	180TC/210C	1.125	0.250 x 0.125	4.63
B11	210TC/250UC	1.375	0.312 x 0.156	4.63

Assembly Types

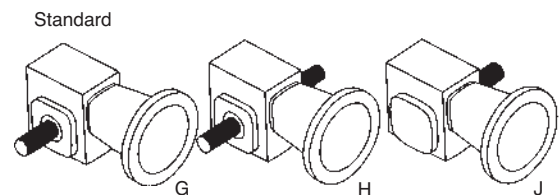

H50
Reducer

900 Series
Single Reduction

900 Series
Double Reduction

Accessories

Ratio Multipliers

In-Line Helical (LH)

Universal Series
Single Reduction

Universal Series
Double Reduction

Engineering

Style LF w/Horizontal Base

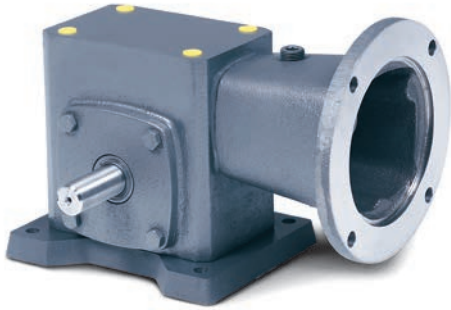

Shown in Position B

900 Series Dimensions Single Reduction Flanged Coupling Type

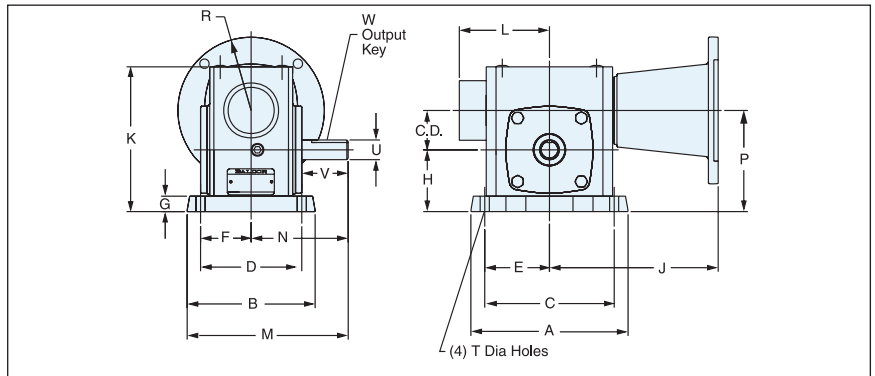

Size	C.D.	A	B	C	D	E	F	G	H	J		K	L Fan Guard	M	N	P
										56C 140TC	180TC 210TC					
913	1.33	5.28	4.19	4.38	3.31	2.19	1.66	0.53	2.25	6.54	—	5.18	—	6.09	4.00	3.58
915	1.54	7.00	5.69	5.25	4.31	2.88	2.25	0.69	2.60	7.31	—	6.07	—	7.16	4.31	3.45
918	1.75	7.00	5.69	5.75	4.50	2.88	2.25	0.69	2.75	7.50	—	6.44	—	7.16	4.31	4.50
921	2.06	7.75	5.94	6.38	4.69	3.19	2.34	0.72	3.00	7.75	—	7.09	—	7.66	4.69	5.06
924	2.38	8.50	6.19	7.06	4.88	3.53	2.44	0.75	3.25	7.94	—	7.69	—	8.19	5.09	5.63
926	2.62	9.63	6.66	8.00	5.25	4.00	2.63	0.75	3.69	9.15	9.96	8.75	—	8.96	5.63	6.31
930	3.00	10.21	7.54	8.44	5.88	4.22	2.94	0.69	4.00	9.87	10.31	9.63	—	10.52	6.75	7.00
932	3.25	11.19	7.66	9.50	6.12	4.75	3.06	0.88	4.38	10.28	11.04	10.25	6.65	10.89	7.06	7.63
938	3.75	12.13	8.66	10.38	7.00	5.19	3.50	0.94	4.82	11.25	11.94	11.82	7.34	11.25	7.75	8.57

Size	T	Output Shaft				Motor Size Available Per Size Any Ratio	Approximate Weight Lbs.	Approximate Capacity Oz.
		U +0.000 -0.001	V	W-Key				
				Sq.	Lgth.			
913	0.343	0.625	2.19	0.187	1.00	B5, B7	19	6.5
915	0.343	0.750	2.06	0.187	1.00	B5, B7	26	10.0
918	0.406	0.875	2.06	0.187	1.00	B5, B7	28	14.0
921	0.468	1.000	2.38	0.250	1.25	B5, B7	36	17.5
924	0.468	1.125	2.66	0.250	1.25	B5, B7	41	26.5
926	0.531	1.125	2.78	0.250	2.00	B5, B7, B9	56	32.0
930	0.468	1.250	3.64	0.250	2.25	B5, B7, B9	80	65.0
932	0.531	1.375	3.44	0.312	2.50	B5, B7, B9	94	67.0
938	0.531	1.625	3.81	0.375	2.75	B7, B9, B11	133	88.0

Rating Information Pages 11 - 13 Optional Base Pages 80 - 81

Motor Information				
Worm Bore Size Designation	NEMA Design	Bore +0.002 -0.000	Key Way	R
B5	56C	0.625	0.187 x 0.093	3.31
B7	140TC/180C	0.875	0.187 x 0.093	3.31
B9	180TC/210C	1.125	0.250 x 0.125	4.63
B11	210TC/250UC	1.375	0.312 x 0.156	4.63

Assembly Types

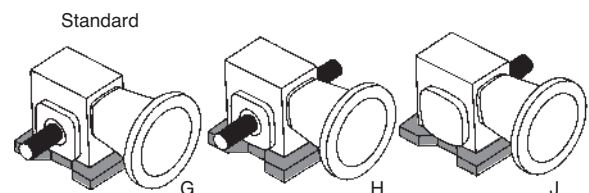

Style LF w/Vertical Base



Shown in Position E/F

900 Series Dimensions Single Reduction Flanged Coupling Type

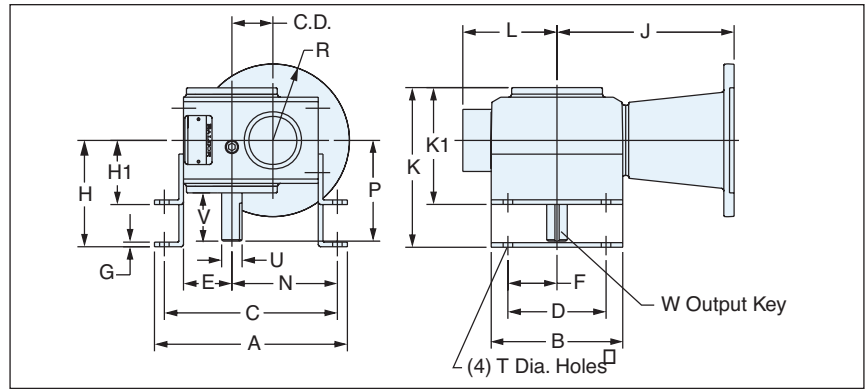

Size	C.D.	A	B	C	D	E	F	G	H	H1	J		K	K ₁	L Fan Guard	N	P
											56C 140TC	180TC 210TC					
913	1.33	7.09	4.12	6.15	3.25	1.72	1.63	0.25	3.56	2.31	6.54	—	5.59	4.34	—	3.68	4.00
915	1.54	8.06	5.16	7.01	4.00	1.91	2.00	0.25	4.38	3.00	7.31	—	6.71	5.33	—	4.28	4.31
918	1.75	8.43	5.16	7.38	4.00	2.06	2.00	0.25	4.38	3.00	7.50	—	6.84	5.47	—	4.50	4.31
921	2.06	9.50	6.03	8.38	4.88	2.28	2.44	0.31	4.88	3.13	7.75	—	7.41	5.66	—	5.09	4.69
924	2.38	10.06	6.31	8.94	4.88	2.50	2.44	0.31	5.25	3.38	7.94	—	7.91	6.03	—	5.44	5.09
926	2.62	11.68	7.38	10.13	5.75	2.94	2.88	0.31	5.59	3.63	9.15	9.96	8.47	6.50	—	6.13	5.63
930	3.00	12.50	8.25	11.13	6.00	3.25	3.00	0.38	5.88	3.94	9.87	10.31	9.00	7.06	—	6.82	6.75
932	3.25	13.38	9.00	11.88	6.12	3.50	3.06	0.38	6.25	4.69	10.28	11.04	9.88	8.31	6.65	7.13	7.06
938	3.75	15.70	10.00	13.94	8.00	3.97	4.00	0.94	7.00	5.25	11.25	11.94	10.96	9.21	7.34	8.32	7.75

Size	T	Output Shaft				Motor Size Available Per Size Any Ratio	Approximate Weight Lbs.	Approximate Oil Capacity Oz.
		U +0.000 -0.001	V	W-Key				
				Sq.	Lgth.			
913	0.343	0.625	2.19	0.187	1.00	B5, B7	20	6.5
915	0.343	0.750	2.06	0.187	1.00	B5, B7	26	10.0
918	0.406	0.875	2.06	0.187	1.00	B5, B7	28	14.0
921	0.468	1.000	2.38	0.250	1.25	B5, B7	36	17.5
924	0.468	1.125	2.66	0.250	1.25	B5, B7	41	26.5
926	0.531	1.125	2.78	0.250	2.00	B5, B7, B9	58	32.0
930	0.531	1.250	3.64	0.250	2.25	B5, B7, B9	80	65.0
932	0.531	1.375	3.44	0.312	2.50	B5, B7, B9	96	67.0
938	0.531	1.625	3.81	0.375	2.75	B7, B9, B11	136	88.0

Rating Information Pages 11 - 13 Optional Base Pages 80 - 81

Motor Information				
Worm Bore Size Designation	NEMA Design	Bore +0.002 -0.000	Key Way	R
B5	56C	0.625	0.187 x 0.093	3.31
B7	140TC/180C	0.875	0.187 x 0.093	3.31
B9	180TC/210C	1.125	0.250 x 0.125	4.63
B11	210TC/250UC	1.375	0.312 x 0.156	4.63

Assembly Types

E/F Positions: E = High Base, F = Low Base

Standard

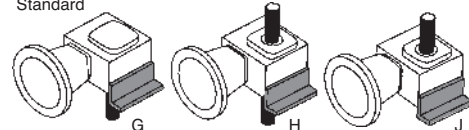

C/D Positions: C = High Base, D = Low Base

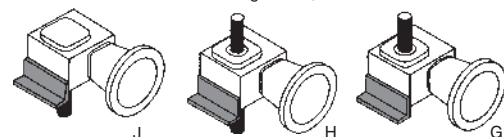

Style LF w/J Mount



Shown in Position X

900 Series Dimensions Single Reduction Flanged Coupling Type

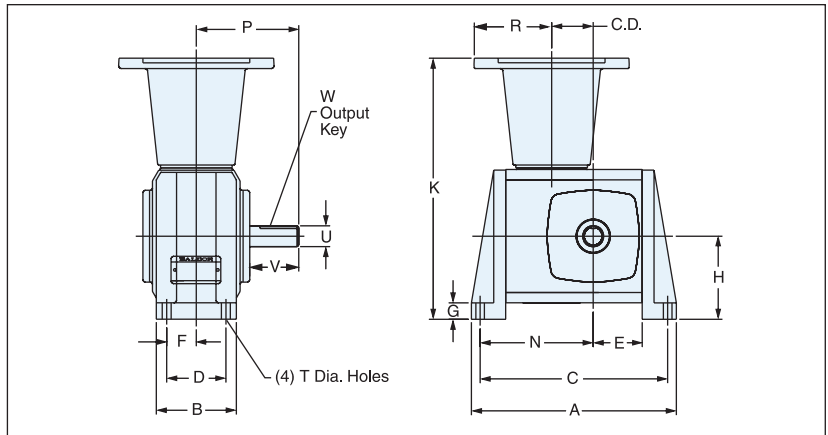

Size	C.D.	A	B	C	D	E	F	G	H	K	N	P	T
913	1.33	7.27	2.88	6.41	2.00	1.72	1.00	0.53	2.94	9.48	3.81	4.00	0.34
915	1.54	8.26	3.38	7.26	2.50	1.91	1.25	0.69	3.50	10.81	4.41	4.31	0.41
918	1.75	8.63	3.38	7.63	2.50	2.06	1.25	0.69	3.50	11.00	4.63	4.31	0.41
921	2.06	9.76	3.75	8.62	2.62	2.28	1.31	0.72	3.94	11.69	5.21	4.69	0.47
924	2.38	10.32	4.06	9.19	2.88	2.50	1.44	0.75	4.06	12.00	5.56	5.09	0.47
926	2.62	11.76	4.44	10.38	3.12	2.94	1.56	0.75	4.75	14.22	6.25	5.63	0.53
930	3.00	12.64	5.06	11.38	3.88	3.25	1.94	0.75	5.62	15.49	6.88	6.75	0.53
932*	3.25	14.00	5.00	12.75	4.00	3.50	2.00	0.81	5.69	15.97	7.57	7.06	0.53

Size	Output Shaft				Motor Size Available Per Size Any Ratio	Approximate Weight Lbs.	Approximate Oil Capacity oz.
	U +0.000 -0.001	V	W-Key				
			Sq.	Lgth.			
913	0.625	2.19	0.187	1.00	B5, B7	20	6.5
915	0.750	2.06	0.187	1.00	B5, B7	28	10.0
918	0.875	2.06	0.187	1.00	B5, B7	28	14.0
921	1.000	2.38	0.250	1.25	B5, B7	36	17.5
924	1.125	2.66	0.250	1.25	B5, B7	41	26.5
926	1.125	2.78	0.250	2.00	B5, B7, B9	58	32.0
930	1.250	3.64	0.250	2.25	B5, B7, B9	80	65.0
932	1.375	3.44	0.312	2.50	B5, B7, B9	96	67.0

* 932 J Base Part Number HA6622A07SP for use less fan. Unit must be derated 33%.
Rating Information Pages 11 - 13
Optional Base Pages 80 - 81

Motor Information				
Coupling Bore Size Designation	NEMA Design	Bore +0.002 -0.000	Key Way	R
B5	56C	0.625	0.187 x 0.093	3.31
B7	140TC/180C	0.875	0.187 x 0.093	3.31
B9	180TC/210C	1.125	0.250 x 0.125	4.63

Assembly Types

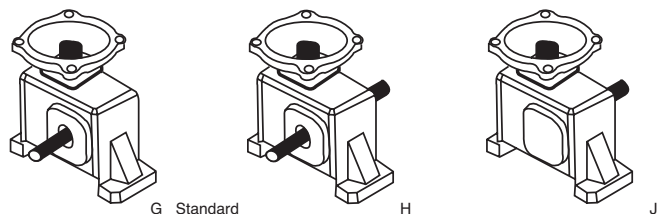

Style LF
w/Output Flange

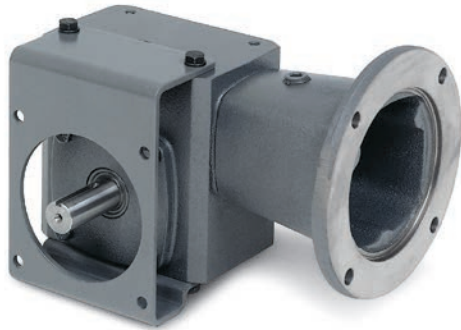

Shown in Position L

900 Series Dimensions
Single Reduction Flanged Coupling Type

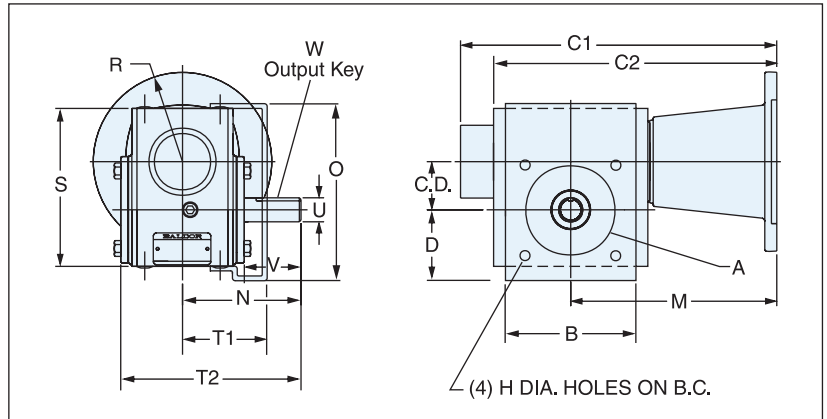

Size	C.D.	A	B	C ₁		C ₂		D	H	B.C.	M		N	O	S	T ₁	T ₂
				56C 140TC	180TC	56C 140TC	180TC				56C 140TC	180TC					
913	1.33	3.63	4.25	—	—	8.67	—	2.43	.344	5.00	6.54	—	4.00	5.56	4.65	3.00	6.03
915	1.54	3.63	4.75	—	—	9.87	—	2.53	.344	5.00	7.31	—	4.31	6.19	5.38	2.54	6.72
918	1.75	4.06	4.81	—	—	10.28	—	2.78	.344	5.87	7.50	—	4.31	6.66	5.75	2.78	6.78
921	2.06	4.50	5.75	—	—	10.78	—	3.14	.406	6.50	7.75	—	4.69	7.43	6.38	3.14	7.22
924	2.38	5.00	6.13	—	—	11.16	—	3.61	.406	7.50	7.94	—	5.09	8.24	6.94	3.61	7.75
926	2.62	6.00	7.18	—	—	13.16	14.42	3.94	.406	8.00	9.47	10.73	5.62	9.25	8.00	4.06	8.50
930	3.00	7.00	8.50	—	—	12.84	13.65	4.14	.406	9.00	9.15	9.96	6.75	10.02	8.88	4.50	9.87
932	3.25	7.00	8.50	16.93	17.64	14.74	15.50	4.75	.563	10.00	10.28	11.04	7.06	10.89	9.38	5.25	10.69
938	3.75	8.00	9.54	18.54	19.28	16.25	16.94	5.04	.563	11.50	11.25	11.94	7.75	11.85	10.44	5.46	11.71

Size	Output Shaft				Motor Size Available Per Size Any Ratio	Approximate Weight Lbs.	Approximate Oil Capacity Oz.
	U +0.000 -0.001	V	W-Key				
			Sq.	Lgth.			
913	0.625	2.19	0.188	1.00	B5, B7	23	6.5
915	0.750	2.06	0.188	1.00	B5, B7	34	10.0
918	0.875	2.06	0.188	1.00	B5, B7	34	14.0
921	1.000	2.38	0.250	1.25	B5, B7	42	17.5
924	1.125	2.66	0.250	1.25	B5, B7	49	26.5
926	1.125	2.78	0.250	2.00	B5, B7, B9	69	32.0
930	1.250	3.64	0.250	2.25	B5, B7, B9	82	65.0
932	1.375	3.44	0.313	2.50	B5, B7, B9	118	67.0
938	1.625	3.81	0.375	2.75	B5, B7, B11	150	88.0

Rating Information Pages 11 - 13

Motor Information				
Worm Bore Size Designation	NEMA Design	Bore +0.002 -0.000	Key Way	R
B5	56C	0.625	0.187 x 0.093	3.31
B7	140TC/180C	0.875	0.187 x 0.093	3.31
B9	180TC/210C	1.125	0.250 x 0.125	4.63
B11	210TC/250UC	1.375	0.312 x 0.156	4.63

Assembly Types

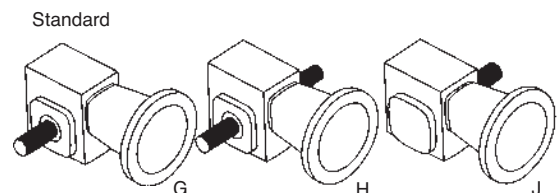

H50
Reducer

900 Series
Single Reduction

900 Series
Double Reduction

Accessories

Ratio Multipliers

In-Line Helical (LH)

Universal Series
Single Reduction

Universal Series
Double Reduction

Engineering

Style HF Hollow Output Shaft



Shown in Basic Position

900 Series Dimensions Single Reduction Flanged Quill Type

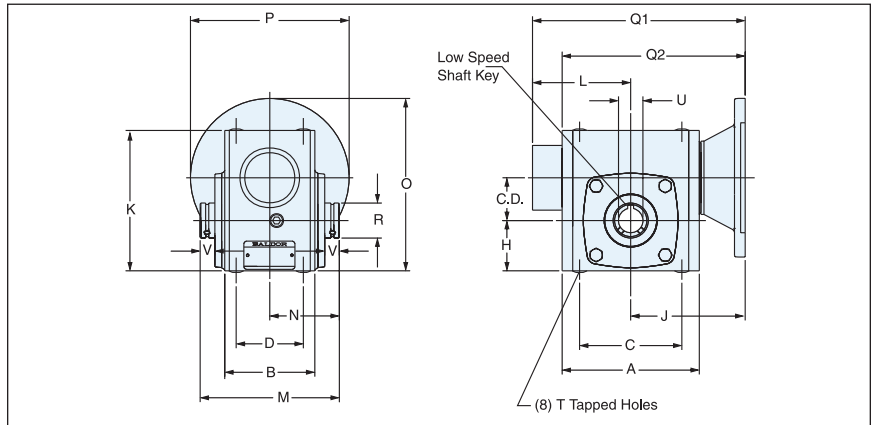

Size	C.D.	A	B	C	D	H	J		L	O		Q ₁		Q ₂		T	
							56C 140TC	180TC		56C 140TC	180TC	56C 140TC	180TC	56C 140TC	180TC	Tap Size	Depth
913	1.33	4.25	2.88	3.25	2.00	1.72	3.94	—	—	6.39	—	—	—	6.10	—	0.312-18	0.62
918	1.75	5.56	3.69	4.19	2.75	2.06	4.69	—	—	7.12	—	—	—	7.47	—	0.312-18	0.62
921	2.06	6.06	3.81	5.00	2.88	2.28	5.07	—	—	7.65	—	—	—	8.10	—	0.375-16	0.75
924	2.38	6.44	4.06	5.00	2.88	2.50	5.25	—	—	8.19	—	—	—	8.47	—	0.375-16	0.75
926	2.62	7.38	4.44	6.38	3.38	2.94	5.75	6.19	—	8.87	10.19	—	—	9.44	9.88	0.375-16	0.75
930	3.00	8.25	5.06	7.00	4.00	8.25	6.15	6.59	—	9.50	10.88	—	—	10.27	10.71	0.437-14	0.88
932	3.25	8.92	5.88	7.50	4.00	3.50	6.56	7.00	6.65	10.06	11.38	13.21	13.65	11.02	11.11	0.437-14	0.88
938	3.75	10.00	6.37	8.50	4.75	3.88	7.07	7.50	7.34	10.88	12.13	14.41	14.84	12.07	12.57	0.500-13	0.75

Size	K	M	N	R	Low Speed Shaft – Standard Bore			Available Per Size Any Ratio	Motor Size Approximate Weight Lbs.	Approximate Oil Capacity oz.
					U +0.0015 -0	V	Key			
913	4.65	5.00	2.50	1.00	0.625	0.69	0.187 x 0.187 x 1.19	B5	15	6.5
918	5.75	5.70	2.85	1.44	1.000	0.60	0.250 x 0.250 x 1.50	B5, B7	29	14.0
921	6.38	6.44	3.22	1.75	1.250	0.63	0.250 x 0.250 x 1.50	B5, B7	29	17.5
924	6.94	6.31	3.15	2.13	1.437	0.50	0.375 x 0.312 x 1.50	B5, B7, B9	42	26.5
926	8.00	6.88	3.44	2.63	1.437	0.58	0.375 x 0.312 x 1.50	B5, B7, B9	51	32.0
930	8.88	8.13	4.06	2.88	1.937	0.81	0.500 x 0.375 x 2.25	B5, B7, B9	73	65.0
932	9.38	8.50	4.25	2.88	1.937	0.81	0.500 x 0.375 x 2.25	B5, B7, B9	92	67.0
938	10.44	9.50	4.75	2.88	2.188	0.81	0.500 x 0.375 x 2.25	B5, B7, B9, B11	122	88.0

Rating Information Pages 11 - 13

Motor Information				
Worm Bore Size Designation	NEMA Design	Bore +0.002 -0.000	Key Way	P
B5	56C	0.625	0.187 x 0.093	3.31
B7	140TC/180C	0.875	0.187 x 0.093	3.31
B9	180TC/210C	1.125	0.250 x 0.125	4.63
B11	210TC/250UC	1.375	0.312 x 0.156	4.63

Hollow Output Shaft Bore Codes										
FRACTION SIZE	OUTPUT BORE CODE	SIZE								DECIMAL SIZE
		913	918	921	924	926	930	932	938	
1/2	008	O								0.500
5/8	010	S	O							0.625
3/4	012	O	O							0.750
1	100		S	O						1.000
1-1/8	102			O	O					1.125
1-3/16	103			O	O	O				1.188
1-1/4	104			S	O	O	O	O		1.250
1-3/8	106				O	O	O	O		1.375
1-7/16	107			O	S	S	O	O	O	1.438
1-1/2	108					O	O	O		1.500
1-15/16	115					O	S	S		1.938
2-1/8	202						O	O	O	2.125
2-3/16	203							O	S	2.188
Max Bore		0.750	1.125	1.625	1.688	2.000	2.188	2.188	2.188	

S = Standard Bore O = Optional Bore

Style HF

Hollow Output Shaft w/Horizontal Base

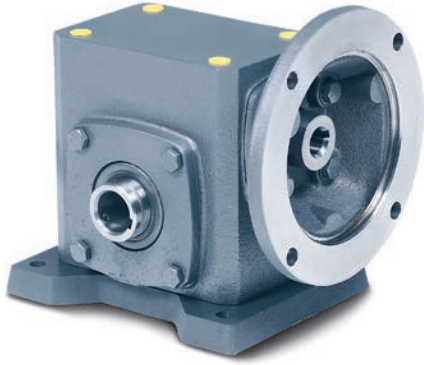

Shown in Position B

900 Series Dimensions Single Reduction Flanged Quill Type

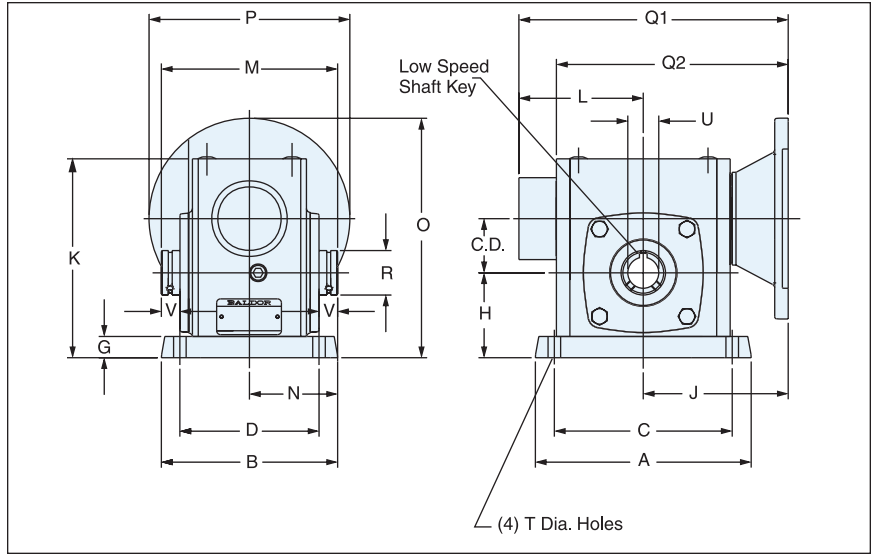

Size	C.D.	A	B	C	D	G	H	J		L	O		Q1		Q2		T
								56C 140TC	180TC		56C 140TC	180TC	56C 140TC	180TC	56C 140TC	180TC	
913	1.33	5.38	4.19	4.38	3.31	0.53	2.25	3.94	—	—	6.89	—	—	—	6.10	—	0.343
918	1.75	7.00	5.69	5.75	4.50	0.69	2.75	4.69	—	—	7.81	—	—	—	7.47	—	0.406
921	2.06	7.75	5.94	6.38	4.69	0.72	3.00	5.07	—	—	8.37	—	—	—	8.10	—	0.468
924	2.38	8.50	6.19	7.06	4.88	0.75	3.25	5.25	—	—	8.94	—	—	—	8.47	—	0.468
926	2.62	9.63	6.66	8.00	5.25	0.75	3.69	5.75	6.19	—	9.62	10.94	—	—	9.44	9.88	0.531
930	3.00	10.21	7.54	8.44	5.88	0.69	4.00	6.25	6.40	—	10.25	11.57	—	—	10.27	10.71	0.468
932	3.25	11.19	7.66	9.50	6.12	0.88	4.38	6.56	7.00	6.65	10.94	12.26	13.21	13.65	11.02	11.11	0.531
938	3.75	12.13	8.66	10.38	7.00	0.94	4.82	7.07	7.50	7.34	12.00	13.32	14.41	14.84	12.07	12.51	0.593

Size	K	M	N	R	Low Speed Shaft			Motor Size Available Per Size Any Ratio	Approximate Weight Lbs.	Approximate Oil Capacity oz.
					U +0.0015 -0	V	Key			
913	5.18	5.00	2.50	1.00	0.625	0.69	0.187 x 0.187 x 1.19	B5	16	6.5
918	6.44	5.70	2.85	1.44	1.000	0.60	0.250 x 0.250 x 1.50	B5, B7	25	14.0
921	7.09	6.44	3.22	1.75	1.250	0.63	0.250 x 0.250 x 1.50	B5, B7	32	17.5
924	7.69	6.31	3.15	2.13	1.437	0.50	0.375 x 0.312 x 1.50	B5, B7, B9	40	26.5
926	8.75	6.88	3.44	2.63	1.437	0.58	0.375 x 0.312 x 1.50	B5, B7, B9	55	32.0
930	9.63	8.13	4.06	2.88	1.937	0.81	0.500 x 0.375 x 2.25	B5, B7, B9	81	65.0
932	10.25	8.50	4.25	2.88	1.937	0.81	0.500 x 0.375 x 2.25	B5, B7, B9	102	67.0
938	11.82	9.50	4.75	2.88	2.188	0.81	0.500 x 0.375 x 2.25	B5, B7, B9, B11	137	88.0

Rating Information Pages 11 - 13 Optional Base Pages 80 - 81

Motor Information

Worm Bore Size Designation	NEMA Design	Bore +0.002 -0.000	Key Way	P
B5	56C	0.625	0.187 x 0.093	6.62
B7	140TC/180C	0.875	0.187 x 0.093	6.62
B9	180TC/210C	1.125	0.250 x 0.125	9.26
B11	210TC/250UC	1.375	0.312 x 0.156	9.26

Style HF

Hollow Output Shaft w/High Vertical Base



Shown in Position E

900 Series Dimensions Single Reduction Flanged Quill Type

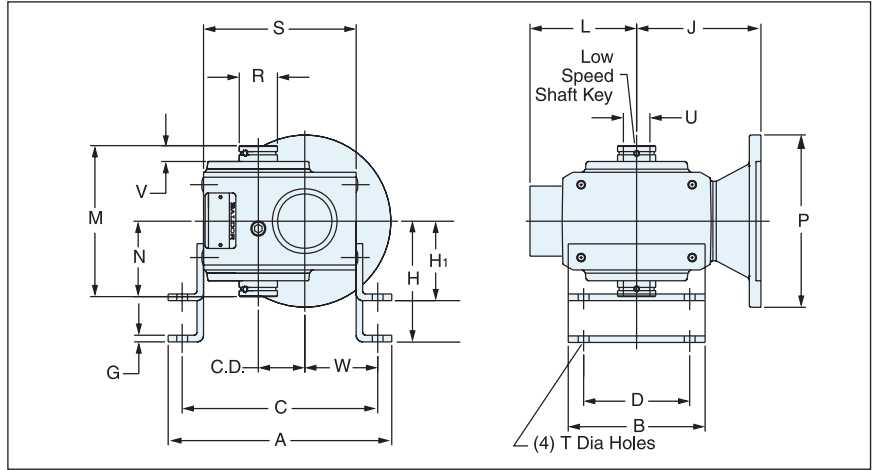

Size	C.D.	A	B	C	D	G	H	H ₁	J		L	N	R	S	T Dia.
									56C 140TC	180TC					
913	1.33	7.09	4.12	6.15	3.25	0.25	3.56	2.31	3.94	—	—	2.50	1.00	4.65	0.343
918	1.75	8.43	5.16	7.37	4.00	0.25	4.38	3.00	4.69	—	—	2.85	1.44	5.75	0.406
921	2.06	9.50	6.03	8.38	4.88	0.31	4.88	3.13	5.07	—	—	3.22	1.75	6.38	0.468
924	2.38	10.06	6.31	8.94	4.88	0.38	5.25	3.38	5.25	—	—	3.15	2.13	6.94	0.468
926	2.62	11.68	7.38	10.12	5.75	0.38	5.60	3.63	5.75	6.19	—	3.44	2.63	8.00	0.531
930	3.00	12.50	8.25	11.13	6.00	0.38	5.88	3.94	6.15	6.59	—	4.06	2.88	2.88	0.531
932	3.25	13.38	9.00	11.88	6.12	0.38	6.25	4.69	6.56	7.00	6.65	4.25	2.88	9.38	0.531
938	3.75	15.70	10.00	13.94	8.00	0.38	5.25	7.00	7.07	7.50	7.34	4.75	2.88	10.44	0.531

Size	M	Low Speed Shaft			W	Motor Size Available Per Size Any Ratio	Approximate Weight Lbs.	Approximate Oil Capacity oz.
		U +0.0015 -0	V	Key				
913	5.00	0.625	0.69	0.187 x 0.187 x 1.19	2.34	B5	16	6.5
918	5.70	1.000	0.60	0.250 x 0.250 x 1.50	2.75	B5, B7	25	14.0
921	6.44	1.250	0.63	0.250 x 0.250 x 1.50	3.04	B5, B7	32	17.6
924	6.31	1.437	0.50	0.375 x 0.312 x 1.50	3.06	B5, B7, B9	40	26.5
926	6.88	1.437	0.58	0.375 x 0.312 x 1.50	3.50	B5, B7, B9	55	32.0
930	8.13	1.937	0.81	0.500 x 0.375 x 2.25	3.75	B5, B7, B9	81	65.0
932	8.50	1.937	0.81	0.500 x 0.375 x 2.25	3.88	B5, B7, B9	82	67.0
938	9.50	2.188	0.81	0.500 x 0.375 x 2.25	4.51	B5, B7, B9, B11	137	88.0

Rating Information Pages 11 - 13 Optional Base Pages 80 - 81

Motor Information				
Worm Bore Size Designation	NEMA Design	Bore +0.002 -0.000	Key Way	P
B5	56C	0.625	0.187 x 0.093	6.62
B7	140TC	0.875	0.187 x 0.093	6.62
B9	180TC	1.125	0.250 x 0.125	9.26
B11	250TC	1.375	0.312 x 0.156	9.26

FRACTION SIZE	OUTPUT BORE CODE	Hollow Output Shaft Bore Codes								DECIMAL SIZE	
		913	918	921	924	926	930	932	938		
1/2	008	O								0.500	
5/8	010	S	O							0.625	
3/4	012	O	O							0.750	
1	100		S	O						1.000	
1-1/8	102			O	O					1.125	
1-3/16	103			O	O	O				1.188	
1-1/4	104			S	O	O	O	O		1.250	
1-3/8	106				O	O	O			1.375	
1-7/16	107			O	S	S	O	O	O	1.438	
1-1/2	108					O	O	O		1.500	
1-15/16	115					O	S	S		1.938	
2-1/8	202						O	O	O	2.125	
2-3/16	203							O	O	S	2.188
Max Bore		0.750	1.125	1.625	1.688	2.000	2.188	2.188	2.188		

S = Standard Bore O = Optional Bore

Style HF

Hollow Output Shaft w/J Mount



Shown in Position X

900 Series Dimensions Single Reduction Flanged Quill Type

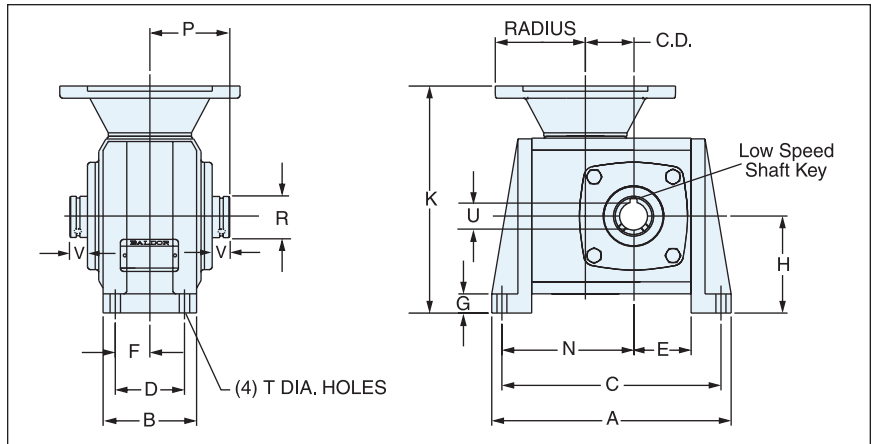

Size	C.D.	A	B	C	D	E	F	G	H	K		N	P	T
										56C 140TC	180TC			
913	1.33	7.27	2.88	6.41	2.00	1.72	1.00	0.53	2.94	6.88	—	3.81	2.50	0.34
918	1.75	8.63	3.38	7.63	2.50	2.06	1.25	0.69	3.50	8.19	—	4.63	2.85	0.41
921	2.06	9.76	3.75	8.62	2.62	2.28	1.31	0.72	3.94	9.01	—	5.21	3.22	0.47
924	2.38	10.32	4.06	9.19	2.88	2.50	1.44	0.75	4.06	9.31	—	5.56	3.15	0.47
926	2.62	11.76	4.44	10.38	3.12	2.94	1.56	0.75	4.75	10.50	10.94	6.25	3.44	0.53
932*	3.25	14.00	6.00	12.75	4.00	3.50	2.00	0.81	5.69	12.25	12.69	7.57	4.25	0.53

Size	R	Low Speed Shaft			Motor Size Available Per Size Any Ratio	Approximate Weight (lbs.)	Approximate Oil Capacity (oz.)
		U +0.0015 -0	V	Key			
913	1.00	0.625	0.69	0.187 x 0.187 x 1.19	B5	17	6.5
918	1.44	1.000	0.60	0.250 x 0.250 x 1.50	B5, B7	26	14.0
921	1.75	1.250	0.63	0.250 x 0.250 x 1.50	B5, B7	32	17.5
924	2.13	1.437	0.50	0.375 x 0.312 x 1.50	B5, B7, B9	40	26.5
926	2.63	1.437	0.58	0.375 x 0.312 x 1.50	B5, B7, B9	57	32.0
932	2.88	1.937	0.81	0.500 x 0.375 x 2.25	B5, B7, B9	97	67.0

* 932J Base Part No. HA6622A07SP for use less fan. Unit must be derated 33%.
Rating Information Pages 11 - 13 Optional Base Pages 80 - 81

Motor Information				
Worm Bore Size Designation	NEMA Design	Bore +0.002 -0.000	Key Way	Radius
B5	56C	0.625	0.187 x 0.093	3.31
B7	140TC/180C	0.875	0.187 x 0.093	3.31
B9	180TC/210C	1.125	0.250 x 0.125	4.63

Style HF

Hollow Output Shaft w/Output Flange

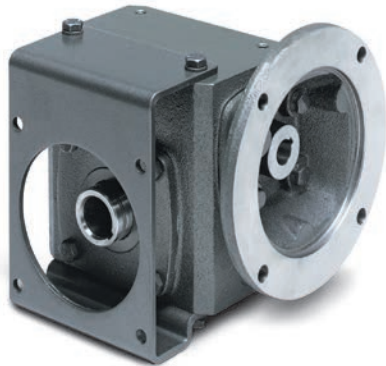

Shown in Position L

900 Series Dimensions

Single Reduction Flanged Quill Type

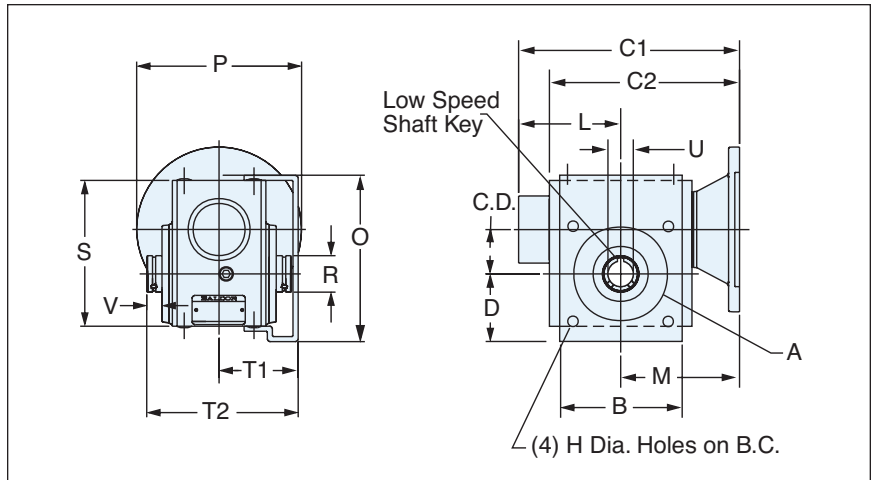

SIZE	C.D.	A	B	BC	C ₁		C ₂		D	H	M		O	R
					56C 140TC	180TC	56C 140TC	180TC			56C 140TC	180TC		
913	1.33	3.63	4.25	5.00	—	—	6.10	—	2.43	0.344	3.94	—	5.56	1.00
918	1.75	4.06	4.81	5.85	—	—	7.47	—	2.78	0.344	4.69	—	6.66	1.44
921	2.06	4.40	5.75	6.50	—	—	8.10	—	3.15	0.406	5.07	—	7.43	1.75
924	2.38	5.00	6.13	7.50	—	—	8.47	—	3.61	0.406	5.25	—	8.24	2.13
926	2.62	6.00	7.18	8.00	—	—	9.44	9.88	3.94	0.406	5.75	6.19	9.25	2.63
930	3.00	7.00	8.50	9.00	—	—	10.27	10.71	4.14	0.406	6.15	6.59	10.02	2.88
932	3.25	7.00	8.50	10.00	13.21	13.65	11.02	11.11	4.75	0.563	6.56	7.00	10.89	2.88
938	3.75	8.00	9.54	11.50	14.41	14.84	12.07	12.57	5.04	0.563	7.07	7.50	11.85	2.88

Size	S	T1	T2	Low Speed Shaft			Motor Size Available Per Size Any Ratio	Approximate Weight Lbs.	Approximate Oil Capacity oz.
				U +0.0015 -0	V	Key			
913	4.65	3.00	5.00	0.625	0.69	0.187 x 0.187 x 1.19	B5	18	6.5
918	5.75	3.51	5.70	1.000	0.60	0.250 x 0.250 x 1.50	B5, B7	26	14.0
921	6.38	3.75	6.44	1.250	0.63	0.250 x 0.250 x 1.50	B5, B7	34	17.5
924	6.94	3.72	6.31	1.437	0.50	0.375 x 0.312 x 1.50	B5, B7, B9	41	26.5
926	8.00	4.06	6.88	1.437	0.58	0.375 x 0.312 x 1.50	B5, B7, B9	59	32.0
930	8.88	4.50	8.13	1.937	0.81	0.500 x 0.375 x 2.25	B5, B7, B9	76	65.0
932	9.38	5.25	8.50	1.937	0.81	0.500 x 0.375 x 2.25	B5, B7, B9	95	67.0
938	10.49	5.46	9.50	2.188	0.81	0.500 x 0.375 x 2.25	B5, B7, B9, B11	125	88.0

Rating Information Pages 11 - 13

Motor Information				
Worm Bore Size Designation	NEMA Design	Bore +0.002 -0.000	Key Way	P
B5	56C	0.625	0.187 x 0.093	6.62
B7	140TC/180C	0.875	0.187 x 0.093	6.62
B9	180TC/210C	1.125	0.250 x 0.125	9.26
B11	250TC	1.375	0.312 x 0.156	9.26

FRACTION SIZE	OUTPUT BORE CODE	Hollow Output Shaft Bore Codes								DECIMAL SIZE
		913	918	921	924	926	930	932	938	
1/2	008	O								0.500
5/8	010	S	O							0.625
3/4	012	O	O							0.750
1	100		S	O						1.000
1-1/8	102			O	O					1.125
1-3/16	103			O	O	O				1.188
1-1/4	104			S	O	O	O	O		1.250
1-3/8	106				O	O	O			1.375
1-7/16	107			O	S	S	O	O	O	1.438
1-1/2	108					O	O	O		1.500
1-15/16	115					O	S	S		1.938
2-1/8	202						O	O	O	2.125
2-3/16	203							O	S	2.188
Max Bore		0.750	1.125	1.625	1.688	2.000	2.188	2.188	2.188	

S = Standard Bore O = Optional Bore

Style HF

Hollow Output Shaft w/Torque Arm Mounting Bracket



900 Series Dimensions Single Reduction Flanged Quill Type

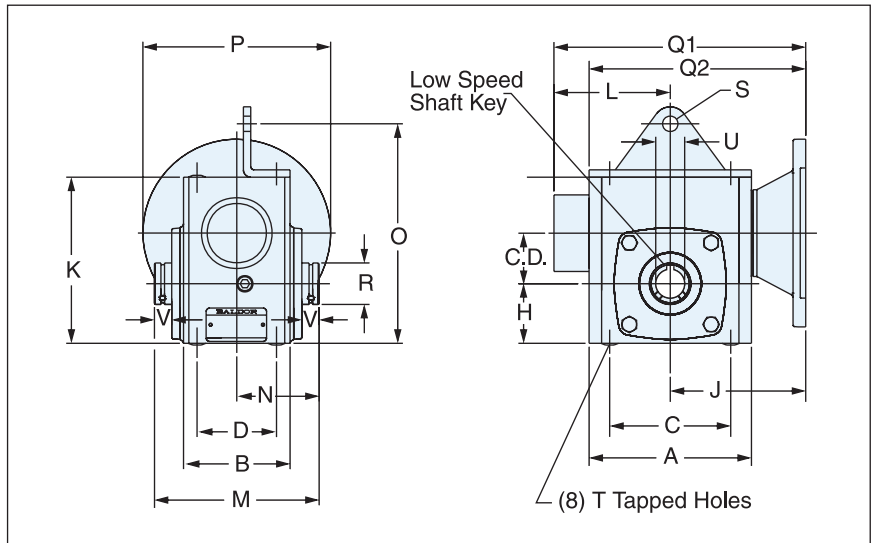

Size	C.D.	A	B	C	D	H	J		L	S	O	Q1		Q2		R	T Tap Size	Depth
							56C 140TC	180TC				56C 140TC	180TC	56C 140TC	180TC			
913	1.33	4.25	2.88	3.25	2.00	1.72	3.94	—	—	0.53	5.87	—	—	6.10	—	1.00	0.156-18	0.62
918	1.75	5.56	3.69	4.19	2.75	2.06	4.69	—	—	0.53	7.12	—	—	7.47	—	1.44	0.156-18	0.62
921	2.06	6.06	3.81	5.00	2.88	2.28	5.07	—	—	0.53	8.35	—	—	8.10	—	1.75	0.375-16	0.75
924	2.38	6.44	4.06	5.00	2.88	2.50	5.25	—	—	0.53	8.91	—	—	8.47	—	2.13	0.375-16	0.75
926	2.62	7.38	4.44	6.38	3.38	2.94	5.75	6.19	—	0.53	10.38	—	—	9.44	9.88	2.63	0.375-16	0.75
930	3.00	8.25	5.06	7.00	4.00	3.25	6.25	6.40	—	0.53	11.50	—	—	10.27	10.71	2.88	0.375-16	0.75
932	3.25	8.92	5.88	7.50	4.00	3.50	6.56	7.00	6.65	0.53	12.57	13.21	13.65	11.02	11.11	2.88	0.437-14	0.88
938	3.75	10.00	6.37	8.50	4.75	3.88	7.07	7.50	7.34	0.53	13.44	14.41	14.84	12.07	12.57	2.88	0.500-13	0.75

Size	K	M	N	Low Speed Shaft			Motor Size Available Per Size Any Ratio	Approximate Weight Lbs.	Approximate Oil Capacity oz.
				U +0.0015 -0	V	Key			
913	4.65	5.00	2.50	0.625	0.69	0.187 x 3.062 x 1.19	B5	15	6.5
918	5.75	5.70	2.85	1.000	0.60	0.250 x 0.250 x 1.50	B5, B7	24	14.0
921	6.38	6.44	3.22	1.250	0.63	0.250 x 0.250 x 1.50	B5, B7	30	17.5
924	6.94	6.31	3.15	1.437	0.50	0.375 x 0.312 x 1.50	B5, B7, B9	37	26.5
926	8.00	6.88	3.44	1.437	0.58	0.375 x 0.312 x 1.50	B5, B7, B9	52	32.0
930	8.88	8.13	4.06	1.937	0.81	0.500 x 0.375 x 2.25	B5, B7, B9	73	65.0
932	9.38	8.50	4.25	1.937	0.81	0.500 x 0.375 x 2.25	B5, B7, B9	87	67.0
938	10.44	9.50	4.75	2.188	0.81	0.500 x 0.375 x 2.25	B5, B7, B9, B11	123	88.0

Rating Information Pages 11 - 13 Optional Torque Arm Page 82

Motor Information

Worm Bore Size Designation	NEMA Design	Bore +0.002 -0.000	Key Way	P
B5	56C	0.625	0.187 x 0.093	6.62
B7	140TC/180C	0.875	0.187 x 0.093	6.62
B9	180TC/210C	1.125	0.250 x 0.125	9.26
B11	250TC	1.375	0.312 x 0.156	9.26

Style HF

Hollow Output Shaft

Position V/W

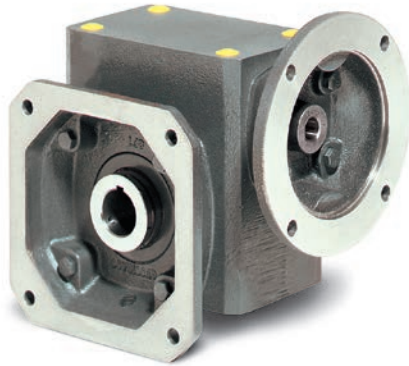

(Position W Shown)

Position V has flange on right hand side.

900 Series Dimensions

Single Reduction Flanged Quill Type

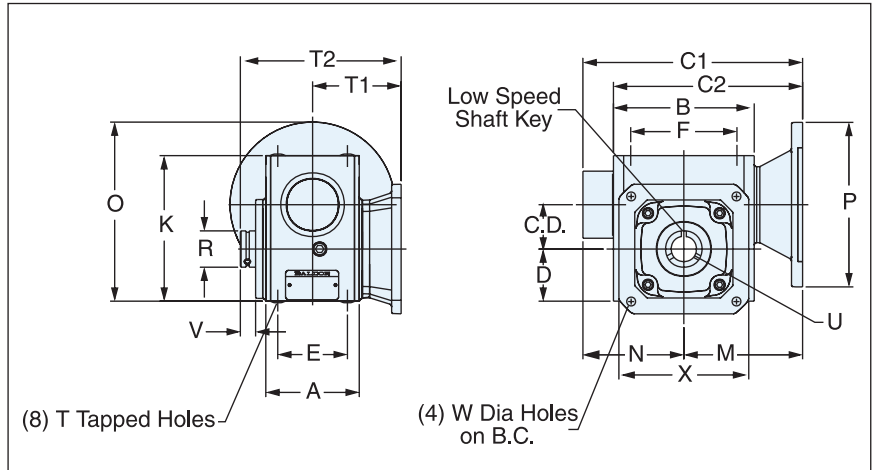

Size	C.D.	A	B	C1		C2		D	E	F	T Tap Size	Depth	M		N	O	
				56C 140TC	180TC	56C 140TC	180TC						56C 140TC	180TC		56C 140TC	180TC
918	1.75	3.69	5.56	—	—	7.47	—	2.06	2.75	4.19	0.312-18	.62	4.69	—	—	7.12	—
921	2.06	3.81	6.06	—	—	8.10	—	2.28	2.88	5.00	0.375-16	.75	5.07	—	—	7.65	—
924	2.38	4.06	6.44	—	—	8.47	—	2.50	2.88	5.00	0.375-16	.75	5.25	—	—	8.19	—
926	2.62	4.44	7.38	—	—	9.44	9.88	2.94	3.38	6.38	0.375-16	.75	5.75	6.19	—	8.87	10.19
932	3.25	5.88	8.92	13.21	13.65	—	—	3.50	4.00	7.50	0.437-14	.88	6.56	7.00	6.65	10.06	11.38

Size	R	K	T ₁	T ₂	U +0.0015 -0	V	W	B.C.	X	Low Speed Shaft Key
918	1.44	5.75	3.50	6.35	1.000	.60	.35	5.88	5.12	0.250 x 0.250 x 1.50
921	1.75	6.38	3.75	6.69	1.250	.63	.41	6.50	5.75	0.250 x 0.250 x 1.50
924	2.13	6.94	3.97	6.90	1.437	.50	.41	7.50	6.75	0.375 x 0.312 x 1.50
926	2.63	8.00	4.05	7.29	1.437	.58	.41	8.00	7.25	0.375 x 0.312 x 1.50
932	2.88	9.38	5.25	9.50	1.937	.81	.57	10.00	9.00	0.500 x 0.375 x 2.25

Rating Information Pages 11 - 13

Size	Motor Size Available Per Size Any Ratio	Approximate Weight Lbs.	Approximate Oil Capacity oz.
918	B5, B7	23	14.0
921	B5, B7	29	17.5
924	B5, B7, B9	36	26.5
926	B5, B7, B9	51	32.0
932	B5, B7, B9	82	67.0

Motor Information

Worm Bore Size Designation	NEMA Design	Bore +0.002 -0.000	Key Way	P
B5	56C	0.625	0.187 x 0.093	6.62
B7	140TC	0.875	0.187 x 0.093	6.62
B9	180TC	1.125	0.250 x 0.125	9.26

FRACTION SIZE	OUTPUT BORE CODE	Hollow Output Shaft Bore Codes								DECIMAL SIZE	
		913	918	921	924	926	930	932	938		
1/2	008	O								0.500	
5/8	010	S	O							0.625	
3/4	012	O	O							0.750	
1	100		S	O						1.000	
1-1/8	102			O	O					1.125	
1-3/16	103			O	O	O				1.188	
1-1/4	104			S	O	O	O	O		1.250	
1-3/8	106				O	O	O			1.375	
1-7/16	107			O	S	S	O	O	O	1.438	
1-1/2	108					O	O	O		1.500	
1-15/16	115					O	S	S		1.938	
2-1/8	202						O	O	O	2.125	
2-3/16	203							O	O	S	2.188
Max Bore		0.750	1.125	1.625	1.688	2.000	2.188	2.188	2.188		

S = Standard Bore O = Optional Bore

900 Series Quill and Bearing Carrier Dimensions

900 NEMA C Quill Type Flange Data

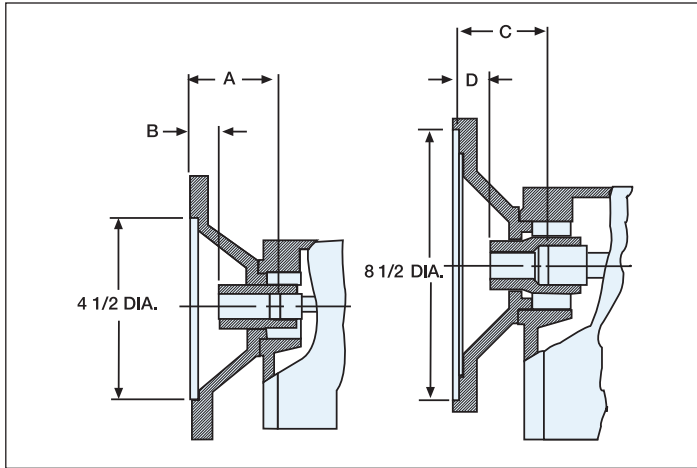

Size	Bore Code	A	B	C	D
913	B5	1.59	.28		
	B5	2.19	.69		
915	B5				
918	B5	2.38	.88		
	B7	2.38	.88		
921	B5	2.38	.88		
	B7	2.38	.88		
924	B5	2.38	.88		
	B7	2.38	.88		
	B9			2.75	1.00
930	B5	2.52	.70	2.96	1.14
	B7				
	B9				
926	B5	2.57	.75		
	B7	2.57	.75		
	B9			2.81	1.00
932	B5	2.57	.75		
	B7	2.57	.75		
	B9			2.81	1.00
938	B5	3.02	.51		
	B7	3.02	.51		
	B9	3.45	.50		

900 Series Output Bearing Carrier

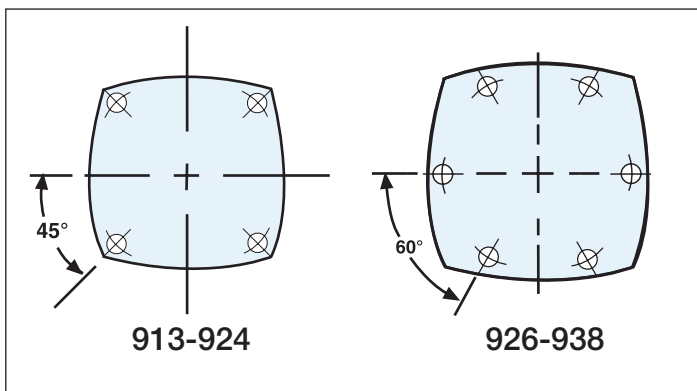

Frame Size	Bolt		
	Cir. Dia	Size	Length
913	3.000	1/4 - 20	0.75
915	3.500	5/16 - 18	0.75
918	4.000	5/16 - 18	0.88
921	4.375	5/16 - 18	0.88
924	4.937	5/16 - 18	0.88
926	5.375	5/16 - 18	0.88
930	6.000	5/16 - 18	0.88
932	6.562	5/16 - 18	0.75
938	7.250	3/8 - 16	1.00

900 Series Input Bearing Carrier

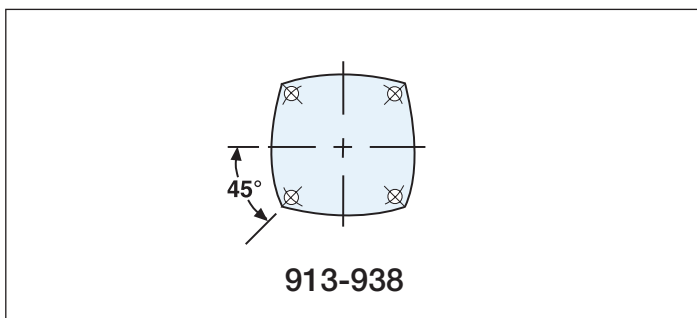

Frame Size	Bolt		
	Cir. Dia	Size	Length
913	2.000	1/4 - 20	0.75
915	2.625	5/16 - 18	0.88
918	2.625	5/16 - 18	0.88
921	3.000	5/16 - 18	0.88
924	3.000	5/16 - 18	0.88
926	3.437	5/16 - 18	0.88
930	3.437	5/16 - 18	0.88
932	3.437	5/16 - 18	0.88
938	4.375	3/8 - 16	1.00

900 Series Double Reduction

Style Reference Guide	54
How to Order	55
Ratings Tables	56 - 65
Dimensions	66 - 77



H50
Reducer

900 Series
Single Reduction

900 Series
Double Reduction

Accessories

Ratio Multiplier

In-Line Helical (LH)

Universal Series
Single Reduction

Universal Series
Double Reduction

Engineering

900 Series Double Reduction Style Reference Guide

H50 Reducer

900 Series Single Reduction

900 Series Double Reduction

Accessories

Ratio Multipliers

In-Line Helical (LH)

Universal Series Single Reduction

Universal Series Double Reduction

Engineering

FDA900



Ratings P. 55 - 65
Dimensions P. 66

FDB900

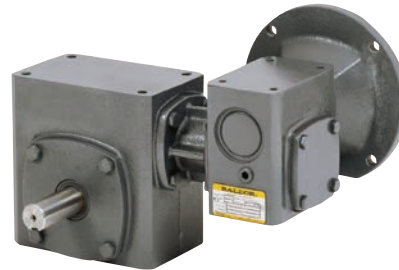

Ratings P. 55 - 65
Dimensions P. 68

FDC900

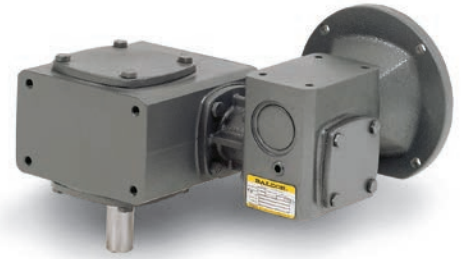

Ratings P. 55 - 65
Dimensions P. 70

LFDA900



Ratings P. 55 - 65
Dimensions P. 66

LFDB900



Ratings P. 55 - 65
Dimensions P. 68

LFDC900



Ratings P. 55 - 65
Dimensions P. 70

DA900



Ratings P. 55 - 65
Dimensions P. 72

DB900



Ratings P. 55 - 65
Dimensions P. 74

DC900



Ratings P. 55 - 65
Dimensions P. 76

DOUBLE REDUCTION UNITS CAN BE ASSEMBLED AT THE FACTORY OR THEY CAN BE ASSEMBLED FROM SINGLE REDUCTION STOCK UNITS IN THE FIELD. SEE PAGE 81 FOR KITS.

Double Reduction 900 Series Numbering System/How to Order

FDA - 924 - B - 120 - B5 - G 107

WASHDOWN OPTIONS
Blank = Standard Finish
SS = Stainless Steel Available in 926 and 932
WD = Washdown

OUTPUT SHAFT
Blank = Standard Shaft
H = Hollow Bore

STYLE
Solid Output Shaft
FDA = Flanged Quill type input
LFDA = Flanged coupling type input
FDB = Flanged Quill type input
LFDB = Flanged coupling type input
FDC = Flanged Quill type input
LFDC = Flanged coupling type input
DA = Solid worm type (projecting input shaft)
DB = Solid worm type (projecting input shaft)
DC = Solid worm type (projecting input shaft)

SIZE (Center Distance)	
913	1.33
918	1.75
921	2.06
924	2.38
926	2.62
930	3.00
932	3.25
938	3.75

BASE/ASSEMBLY	
A	= Horizontal base, worm under gear
B	= Horizontal base, worm over gear
C	= Vertical base, High
D	= Vertical base, Low
E	= Vertical base, High
F	= Vertical base, Low
R/L	= Steel output flange
V/W	= Cast iron output flange
X	= Vertical base, J mount
BRB	= Horizontal base with riser block

RATIO
75:1 THROUGH 3600:1
See ratio and capacity selection tables for available ratios, p. 54-63.

NEMA INPUT BORE CODES		
Bore Code	Input Bore	NEMA Mtg.
B5	.625	56C
B7	.875	140TC/180C
B9	1.125	180TC/210C
B11	1.375	210TC/250UC

OUTPUT SHAFT ASSEMBLY
See dimension pages for available assemblies

HOLLOW OUTPUT SHAFT BORE CODES										
FRACTION SIZE	OUTPUT BORE CODE	SIZE								DECIMAL SIZE
		913	918	921	924	926	930	932	938	
1/2	008	O								0.500
5/8	010	S	O							0.625
3/4	012	O	O							0.750
1	100		S	O						1.000
1-1/8	102			O	O					1.125
1-3/16	103			O	O	O				1.188
1-1/4	104			S	O	O	O	O		1.250
1-3/8	106				O	O	O			1.375
1-7/16	107			O	S	S	O	O	O	1.438
1-1/2	108					O	O	O		1.500
1-15/16	115					O	S	S		1.938
2-1/8	202						O	O	O	2.125
2-3/16	203						O	O	S	2.188
Max Bore		0.750	1.125	1.625	1.688	2.000	2.188	2.188	2.188	

S = Standard Bore O = Optional Bore

HOW TO ORDER

Please specify Style, Size, Base (if required), Ratio, NEMA Input Flange (if flanged reducer), Output shaft assembly.

EXAMPLE

Required size: Quill type input, 924, 120:1 ratio, 56C input flange, left hand output (facing input) with a horizontal base (worm over gear).

1. Reducer and base assembly
Order Reducer **FDA-924B-120-B5-G**
2. As an option, Double Reduction Units may be assembled from Single Reduction stock using the Adapter Kits on page 81.

900 Series Double Reduction Ratio and Capacity Selection Tables

1750 RPM

913 - 913

H50 Reducer

900 Series Single Reduction

900 Series Double Reduction

Accessories

Ratio Multipliers

In-Line Helical (LH)

Universal Series Single Reduction

Universal Series Double Reduction

Engineering

Final Ratio	1st Reduction 913 : 1	2nd Reduction 913 : 1	Output RPM	Input Hp	Output Hp	Output Torque
75	5	15	23.3	0.25	0.110	298
100	5	20	17.5	0.24	0.086	311
125	5	25	14.0	0.25	0.065	291
150	5	30	11.7	0.14	0.059	320
200	10	20	8.8	0.16	0.045	323
225	15	15	7.8	0.08	0.038	311
300	10	30	5.8	0.12	0.031	332
375	25	15	4.7	0.08	0.023	313
400	20	20	4.4	0.10	0.023	328
450	15	30	3.9	0.10	0.021	336
500	20	25	3.5	0.05	0.017	304
600	20	30	2.9	0.07	0.016	338
625	25	25	2.8	0.04	0.014	305
750	25	30	2.3	0.05	0.013	340
800	40	20	2.2	0.07	0.011	331
900	30	30	1.9	0.03	0.010	340
1000	25	40	1.8	0.04	0.009	330
1200	40	30	1.5	0.06	0.008	341
1250	50	25	1.4	0.03	0.007	307
1500	50	30	1.2	0.05	0.006	342
1600	40	40	1.1	0.05	0.006	331
1800	60	30	1.0	0.02	0.005	343
2000	50	40	0.9	0.02	0.005	332
2400	60	40	0.7	0.03	0.004	332
2500	50	50	0.7	0.03	0.003	292
3000	50	60	0.6	0.02	0.003	369
3600	60	60	0.5	0.02	0.002	270

NOTES: Double Reduction Adapter Kit P/N DR913X913B5
Assembly instructions page 185

Overhung Load Input Shaft 150 lbs.
Overhung Load Output Shaft 240 lbs.
Output Shaft Thrust Load 300 lbs.

900 Series Double Reduction Ratio and Capacity Selection Tables

1750 RPM

918 - 913

Final Ratio	1st Reduction 913 : 1	2nd Reduction 918 : 1	Output RPM	Input Hp	Output Hp	Output Torque
75	5	15	23.3	0.39	0.217	585
100	5	20	17.5	0.39	0.177	636
112.5	15	7.5	15.6	0.29	0.134	543
125	5	25	14.0	0.34	0.141	635
150	5	30	11.7	0.34	0.123	663
187.5	25	7.5	9.3	0.21	0.081	548
200	5	40	8.8	0.26	0.088	631
225	15	15	7.8	0.18	0.075	610
250	10	25	7.0	0.22	0.073	660
300	10	30	5.8	0.23	0.064	689
375	15	25	4.7	0.16	0.050	669
400	20	20	4.4	0.14	0.046	669
450	15	30	3.9	0.18	0.043	697
500	20	25	3.5	0.13	0.037	673
600	20	30	2.9	0.14	0.032	701
625	25	25	2.8	0.12	0.030	676
750	25	30	2.3	0.14	0.026	704
750	50	15	2.3	0.09	0.023	619
800	40	20	2.2	0.09	0.023	675
900	30	30	1.9	0.11	0.022	706
1000	40	25	1.8	0.08	0.019	680
1200	40	30	1.5	0.10	0.016	708
1250	50	25	1.4	0.08	0.015	681
1500	50	30	1.2	0.10	0.013	709
1600	40	40	1.1	0.06	0.012	668
1800	60	30	1.0	0.09	0.011	710
2000	50	40	0.9	0.06	0.009	669
2400	60	40	0.7	0.06	0.008	670
2500	50	50	0.7	0.05	0.007	610
3000	60	50	0.6	0.04	0.006	610
3600	60	60	0.5	0.04	0.004	566

NOTES: Double Reduction Adapter Kit P/N DR913X918B5
 * 918 Gearbox must have a 56C input
 Assembly instructions page 185

Overhung Load Input Shaft 150 lbs.
 Overhung Load Output Shaft 600 lbs.
 Output Shaft Thrust Load 500 lbs.

H50 Reducer

900 Series Single Reduction

900 Series Double Reduction

Accessories

Ratio Multiplier

In-Line Helical (L-H)

Universal Series Single Reduction

Universal Series Double Reduction

Engineering

900 Series Double Reduction Ratio and Capacity Selection Tables

1750 RPM

921 - 913

H50 Reducer

900 Series Single Reduction

900 Series Double Reduction

Accessories

Ratio Multipliers

In-Line Helical (LH)

Universal Series Single Reduction

Universal Series Double Reduction

Engineering

Final Ratio	1st Reduction 913 : 1	2nd Reduction 921 : 1	Output RPM	Input Hp	Output Hp	Output Torque
75	5	15	23.3	0.55	0.362	977
100	5	20	17.5	0.45	0.279	1006
112.5	15	7.5	15.6	0.45	0.233	946
125	5	25	14.0	0.41	0.225	1013
150	10	15	11.7	0.34	0.188	1017
187.5	25	7.5	9.3	0.33	0.142	958
200	10	20	8.8	0.29	0.145	1047
225	15	15	7.8	0.26	0.127	1031
250	10	25	7.0	0.26	0.118	1060
300	15	20	5.8	0.22	0.098	1060
375	15	25	4.7	0.20	0.080	1075
400	20	20	4.4	0.17	0.074	1067
450	30	15	3.9	0.15	0.064	1044
500	20	25	3.5	0.15	0.060	1083
600	30	20	2.9	0.13	0.050	1074
625	25	25	2.8	0.14	0.048	1088
750	30	25	2.3	0.12	0.040	1091
800	40	20	2.2	0.11	0.037	1078
900	60	15	1.9	0.12	0.032	1051
1000	40	25	1/8	0.10	0.030	1094
1200	60	20	1/5	0.10	0.025	1081
1250	50	25	1.4	0.10	0.024	1097
1500	60	25	1.2	0.09	0.020	1098
1600	40	40	1.1	0.06	0.019	1073
1800	60	30	1.0	0.10	0.016	1057
2000	50	40	0.9	0.06	0.015	1075
2400	60	40	0.7	0.06	0.012	1076
2500	50	50	0.7	0.08	0.011	985
3000	60	50	0.6	0.07	0.009	986
3600	60	60	0.5	0.06	0.007	953

NOTES: Double Reduction Adapter Kit P/N DR913X921B5
 * 921 Gearbox must have a 56C input
 Assembly instructions page 185

Overhung Load Input Shaft 150 lbs.
 Overhung Load Output Shaft 750 lbs.
 Output Shaft Thrust Load 700 lbs.

900 Series Double Reduction Ratio and Capacity Selection Tables

1750 RPM

924 - 913

Final Ratio	1st Reduction 913 : 1	2nd Reduction 924 : 1	Output RPM	Input Hp	Output Hp	Output Torque
75	5	15	23.3	0.89	0.582	1571
100	5	20	17.5	0.71	0.444	1599
125	5	25	14.0	0.61	0.335	1508
150	5	30	11.7	0.61	0.307	1657
200	10	20	8.8	0.46	0.232	1673
225	15	15	7.8	0.42	0.207	1681
300	10	30	5.8	0.43	0.160	1729
375	25	15	4.7	0.31	0.126	1701
400	20	20	4.4	0.27	0.119	1710
450	15	30	3.9	0.33	0.108	1752
500	25	20	3.5	0.25	0.095	1717
600	20	30	2.9	0.26	0.082	1765
625	25	25	2.8	0.21	0.072	1621
750	25	30	2.3	0.25	0.066	1772
800	40	20	2.2	0.18	0.060	1728
900	30	30	1.9	0.21	0.055	1777
1000	50	20	1.8	0.18	0.048	1732
1200	40	30	1.5	0.18	0.041	1783
1250	50	25	1.4	0.15	0.036	1635
1500	50	30	1.2	0.18	0.033	1789
1600	40	40	1.1	0.10	0.030	1720
1800	60	30	1.0	0.16	0.028	1789
2000	50	40	0.9	0.10	0.024	1724
2400	60	40	0.7	0.09	0.020	1726
2500	50	50	0.7	0.13	0.018	1619
3000	60	50	0.6	0.12	0.015	1621
3600	60	60	0.5	0.09	0.012	1559

NOTES: Double Reduction Adapter Kit P/N DR913X924B5
 * 924 Gearbox must have a 56C input
 Assembly instructions page 185

Overhung Load Input Shaft 150 lbs.
 Overhung Load Output Shaft 1000 lbs.
 Output Shaft Thrust Load 800 lbs.

H50
Reducer

900 Series
Single Reduction

900 Series
Double Reduction

Accessories

Ratio Multiplier

In-Line Helical (L-H)

Universal Series
Single Reduction

Universal Series
Double Reduction

Engineering

900 Series Double Reduction Ratio and Capacity Selection Tables

1750 RPM

926 - 913

Final Ratio	1st Reduction 913 : 1	2nd Reduction 926 : 1	Output RPM	Input Hp	Output Hp	Output Torque
75	5	15	23.3	1.09	0.713	1925
100	5	20	17.5	0.92	0.570	2054
112.5	15	7.5	15.6	0.66	0.342	1384
125	5	25	14.0	0.79	0.436	1963
150	10	15	11.7	0.67	0.373	2016
187.5	25	7.5	9.3	0.46	0.198	1338
200	10	20	8.8	0.59	0.298	2146
225	15	15	7.8	0.51	0.253	2047
250	10	25	7.0	0.50	0.228	2054
300	15	20	5.8	0.45	0.201	2177
375	15	25	4.7	0.38	0.154	2084
400	20	20	4.4	0.34	0.152	2192
450	15	30	3.9	0.40	0.130	2112
500	25	20	3.5	0.33	0.122	2201
600	30	20	2.9	0.27	0.102	2208
625	25	25	2.8	0.28	0.094	2108
750	25	30	2.3	0.30	0.079	2134
800	40	20	2.2	0.23	0.077	2215
900	30	30	1.9	0.25	0.066	2139
1000	50	20	1.8	0.23	0.062	2220
1200	60	20	1.5	0.21	0.051	2223
1250	25	50	1.4	0.24	0.046	2067
1500	25	60	1.2	0.17	0.036	1945
1600	40	40	1.1	0.13	0.038	2207
1800	60	30	1.0	0.20	0.033	2153
2000	50	40	0.9	0.13	0.031	2211
2400	60	40	0.7	0.12	0.026	2214
2500	50	50	0.7	0.17	0.023	2085
3000	60	50	0.6	0.15	0.019	2088
3600	60	60	0.5	0.11	0.015	1963

NOTES: Double Reduction Adapter Kit P/N DR913X926B5
 * 926 Gearbox must have a 56C input
 Assembly instructions page 185

Overhung Load Input Shaft 150 lbs.
 Overhung Load Output Shaft 1100 lbs.
 Output Shaft Thrust Load 900 lbs.

H50 Reducer
 900 Series Single Reduction
 900 Series Double Reduction
 Accessories
 Ratio Multipliers
 In-Line Helical (LH)
 Universal Series Single Reduction
 Universal Series Double Reduction
 Engineering

900 Series Double Reduction Ratio and Capacity Selection Tables

1750 RPM

924 - 918

Final Ratio	1st Reduction 918 : 1	2nd Reduction 924 : 1	Output RPM	Input Hp	Output Hp	Output Torque
75	5	15	23.3	0.83	0.582	1571
100	5	20	17.5	0.66	0.444	1599
112.5	7.5	15	15.6	0.61	0.403	1631
125	5	25	14.0	0.57	0.335	1508
150	5	30	11.7	0.57	0.307	1657
187.5	7.5	25	9.3	0.42	0.230	1555
200	10	20	8.8	0.40	0.232	1673
225	7.5	30	7.8	0.45	0.210	1705
250	10	25	7.0	0.34	0.175	1578
300	10	30	5.8	0.38	0.160	1729
375	25	15	4.7	0.27	0.126	1701
400	20	20	4.4	0.24	0.119	1710
450	15	30	3.9	0.27	0.108	1752
500	25	20	3.5	0.22	0.095	1717
600	20	30	2.9	0.24	0.082	1765
625	25	25	2.8	0.19	0.072	1621
750	25	30	2.3	0.22	0.066	1772
800	20	40	2.2	0.15	0.059	1702
900	15	60	1.9	0.15	0.047	1527
1000	20	50	1.8	0.10	0.044	1600
1200	20	60	1.5	0.13	0.036	1538
1250	25	50	1.4	0.16	0.036	1606
1500	25	60	1.2	0.12	0.029	1544
1600	40	40	1.1	0.10	0.030	1720
1800	60	30	1.0	0.15	0.028	1789
2000	50	40	0.9	0.08	0.024	1724
2400	60	40	0.7	0.08	0.020	1726
2500	50	50	0.7	0.10	0.018	1619
3000	60	50	0.6	0.11	0.015	1621
3600	60	60	0.5	0.08	0.012	1559

NOTES: Double Reduction Adapter Kit P/N DR913X924B7
 * 924 Gearbox must have a 56C input
 Assembly instructions page 185

Overhung Load Input Shaft 175 lbs.
 Overhung Load Output Shaft 1000 lbs.
 Output Shaft Thrust Load 800 lbs.

H50
Reducer

900 Series
Single Reduction

900 Series
Double Reduction

Accessories

Ratio Multiplier

In-Line Helical (LH)

Universal Series
Single Reduction

Universal Series
Double Reduction

Engineering

900 Series Double Reduction Ratio and Capacity Selection Tables

1750 RPM

926 - 918

Final Ratio	1st Reduction 918 : 1	2nd Reduction 926 : 1	Output RPM	Input Hp	Output Hp	Output Torque
75	5	15	23.3	1.01	0.713	1925
100	5	20	17.5	0.85	0.570	2054
112.5	7.5	15	15.6	0.71	0.475	1925
125	5	25	14.0	0.74	0.436	1963
150	7.5	20	11.7	0.60	0.380	2054
187.5	7.5	25	9.3	0.52	0.291	1963
200	10	20	8.8	0.52	0.298	2146
225	15	15	7.8	0.42	0.253	2047
250	10	25	7.0	0.44	0.228	2054
300	15	20	5.8	0.36	0.201	2177
375	15	25	4.7	0.31	0.154	2084
400	20	20	4.4	0.31	0.152	2192
450	15	30	3.9	0.33	0.130	2112
500	25	20	3.5	0.29	0.122	2201
600	30	20	2.9	0.25	0.102	2208
625	25	25	2.8	0.24	0.094	2108
750	25	30	2.3	0.26	0.079	2134
800	20	40	2.2	0.19	0.076	2185
900	15	60	1.9	0.19	0.059	1925
1000	20	50	1.8	0.13	0.057	2058
1200	20	60	1.5	0.16	0.045	1938
1250	25	50	1.4	0.21	0.046	2067
1500	25	60	1.2	0.15	0.036	1945
1600	40	40	1.1	0.13	0.038	2207
1800	60	30	1.0	0.18	0.033	2153
2000	50	40	0.9	0.11	0.031	2211
2400	60	40	0.7	0.11	0.026	2214
2500	50	50	0.7	0.14	0.023	2085
3000	60	50	0.6	0.14	0.019	2088
3600	60	60	0.5	0.10	0.015	1963

NOTES: Double Reduction Adapter Kit P/N DR918X926B7
 * 926 Gearbox must have a 140TC input
 Assembly instructions page 185

Overhung Load Input Shaft 175 lbs.
 Overhung Load Output Shaft 1100 lbs.
 Output Shaft Thrust Load 900 lbs.

H50 Reducer
 900 Series Single Reduction
 900 Series Double Reduction
 Accessories
 Ratio Multipliers
 In-Line Helical (LH)
 Universal Series Single Reduction
 Universal Series Double Reduction
 Engineering

900 Series Double Reduction Ratio and Capacity Selection Tables

1750 RPM

930 - 918

Final Ratio	1st Reduction 918 : 1	2nd Reduction 930 : 1	Output RPM	Input Hp	Output Hp	Output Torque
75	5	15	28.3	2.02	1.422	3840
100	5	20	17.5	1.44	0.966	3480
112.5	7.5	15	15.6	1.47	0.987	3999
125	5	25	14.0	1.51	0.888	3997
150	5	30	11.7	1.46	0.781	4220
187.5	7.5	25	9.3	1.09	0.616	4159
200	5	40	8.8	1.14	0.563	4053
225	7.5	30	7.8	1.06	0.542	4390
250	10	25	7.0	0.91	0.471	4240
300	10	30	5.8	0.97	0.411	4445
375	15	25	4.7	0.64	0.320	4320
400	10	40	4.4	0.65	0.296	4259
450	15	30	3.9	0.70	0.279	4520
500	20	25	3.5	0.55	0.242	4361
600	20	30	2.9	0.61	0.211	4558
625	25	25	2.8	0.51	0.195	4385
750	25	30	2.3	0.57	0.170	4580
800	20	40	2.2	0.37	0.151	4362
900	30	30	1.9	0.50	0.142	4595
1000	40	25	1.8	0.39	0.123	4421
1200	40	30	1.5	0.45	0.107	4614
1250	25	50	1.4	0.39	0.085	3817
1500	25	60	1.2	0.28	0.068	3647
1600	40	40	1.1	0.26	0.077	4414
1800	60	30	1.0	0.38	0.071	4633
2000	50	40	0.9	0.21	0.061	4424
2400	60	40	0.7	0.22	0.051	4431
2500	50	50	0.7	0.25	0.043	3838
3000	60	50	0.6	0.25	0.036	3843
3600	60	60	0.5	0.19	0.028	3679

NOTES: Double Reduction Adapter Kit P/N DR918X926B7 **
 * 930 Gearbox must have a 140TC input
 Assembly instructions page 185
 ** DR918X926B7 works on both 926 and 930 size reducers

Overhung Load Input Shaft 175 lbs.
 Overhung Load Output Shaft 1100 lbs.
 Output Shaft Thrust Load 900 lbs.

H50
Reducer

900 Series
Single Reduction

900 Series
Double Reduction

Accessories

Ratio Multiplier

In-Line Helical (LH)

Universal Series
Single Reduction

Universal Series
Double Reduction

Engineering

900 Series Double Reduction Ratio and Capacity Selection Tables

1750 RPM

932 - 918

Final Ratio	1st Reduction 918 : 1	2nd Reduction 932 : 1	Output RPM	Input Hp	Output Hp	Output Torque
75	5	15	28.3	2.02	1.422	3840
100	5	20	17.5	1.44	0.966	3480
112.5	7.5	15	15.6	1.47	0.987	3999
125	5	25	14.0	1.51	0.888	3997
150	5	30	11.7	1.46	0.781	4220
187.5	7.5	25	9.3	1.09	0.616	4159
200	5	40	8.8	1.14	0.563	4053
225	7.5	30	7.8	1.06	0.542	4390
250	10	25	7.0	0.91	0.471	4240
300	10	30	5.8	0.97	0.411	4445
375	15	25	4.7	0.64	0.320	4320
400	10	40	4.4	0.65	0.296	4259
450	15	30	3.9	0.70	0.279	4520
500	20	25	3.5	0.55	0.242	4361
600	20	30	2.9	0.61	0.211	4558
625	25	25	2.8	0.51	0.195	4385
750	25	30	2.3	0.57	0.170	4580
800	20	40	2.2	0.37	0.151	4362
900	30	30	1.9	0.50	0.142	4595
1000	40	25	1.8	0.39	0.123	4421
1200	40	30	1.5	0.45	0.107	4614
1250	25	50	1.4	0.39	0.085	3817
1500	25	60	1.2	0.28	0.068	3647
1600	40	40	1.1	0.26	0.077	4414
1800	60	30	1.0	0.38	0.071	4633
2000	50	40	0.9	0.21	0.061	4424
2400	60	40	0.7	0.22	0.051	4431
2500	50	50	0.7	0.25	0.043	3838
3000	60	50	0.6	0.25	0.036	3843
3600	60	60	0.5	0.19	0.028	3679

NOTES: Double Reduction Adapter Kit P/N DR918X932B7
 * 932 Gearbox must have a 140TC input
 Assembly instructions page 185

Overhung Load Input Shaft 175 lbs.
 Overhung Load Output Shaft 1500 lbs.
 Output Shaft Thrust Load 1100 lbs.

H50 Reducer
 900 Series Single Reduction
 900 Series Double Reduction
 Accessories
 Ratio Multipliers
 In-Line Helical (LH)
 Universal Series Single Reduction
 Universal Series Double Reduction
 Engineering

900 Series Double Reduction Ratio and Capacity Selection Tables

1750 RPM

938 - 924

Final Ratio	1st Reduction 918 : 1	2nd Reduction 938 : 1	Output RPM	Input Hp	Output Hp	Output Torque
75	5	15	23.3	3.21	2.224	6007
100	10	10	17.5	2.60	1.714	6173
112.5	15	7.5	15.6	1.96	1.471	5960
125	10	12.5	14.0	2.00	1.426	6418
150	10	15	11.7	1.88	1.213	6555
187.5	15	12.5	9.3	1.40	0.977	6597
200	10	20	8.8	1.57	0.928	6683
225	15	15	7.8	1.32	0.831	6737
250	10	25	7.0	1.35	0.747	6730
300	15	20	5.8	1.12	0.635	6866
312.5	25	12.5	5.6	0.90	0.599	6743
375	15	25	4.7	0.99	0.512	6916
400	20	20	4.4	0.87	0.483	6960
450	15	30	3.9	0.84	0.427	6925
500	25	20	3.5	0.72	0.390	7015
600	30	20	2.9	0.67	0.326	7052
625	25	25	2.8	0.65	0.314	7066
750	30	25	2.3	0.61	0.263	7103
800	40	20	2.2	0.54	0.246	7098
900	30	30	1.9	0.49	0.220	7115
1000	40	25	1.8	0.50	0.199	7150
1200	40	30	1.5	0.40	0.166	7162
1250	50	25	1.4	0.47	0.159	7178
1500	60	25	1.2	0.42	0.133	7197
1600	40	40	1.1	0.31	0.122	7054
1800	60	30	1.0	0.33	0.111	7209
2000	50	40	0.9	0.29	0.098	7082
2400	60	40	0.7	0.26	0.082	7099
2500	50	50	0.7	0.34	0.076	6813
3000	60	50	0.6	0.30	0.063	6830

NOTES: Double Reduction Adapter Kit P/N DR924X938B9
 * 938 Gearbox must have a 180TC input
 Assembly instructions page 185

Overhung Load Input Shaft 200 lbs.
 Overhung Load Output Shaft 1500 lbs.
 Output Shaft Thrust Load 1100 lbs.

H50
Reducer

900 Series
Single Reduction

900 Series
Double Reduction

Accessories

Ratio Multiplier

In-Line Helical (LH)

Universal Series
Single Reduction

Universal Series
Double Reduction

Engineering

**Style FDA
Style LFDA**

**900 Series Dimensions
Double Reduction Flanged Quill/Coupling Type**

Basic

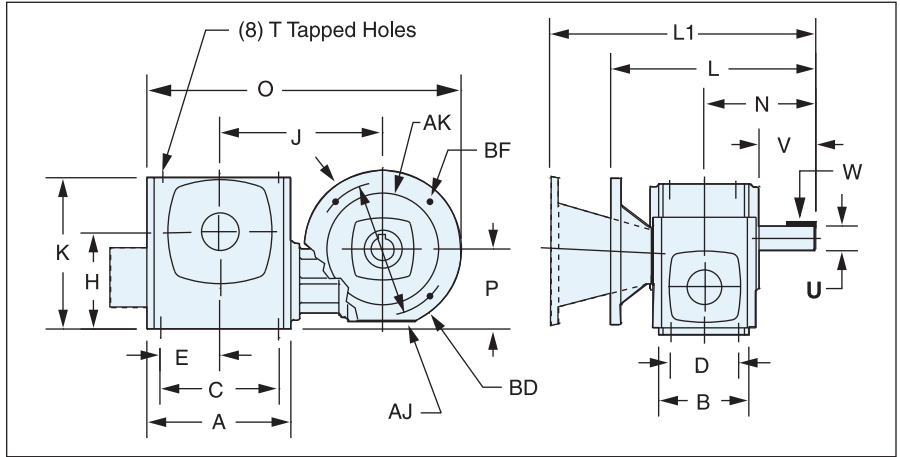

Size	A	B	C	D	E	H	J	K	L	L ₁	N	O	P	T	
														Tap Size	Depth 0.62
913-913	4.31	2.88	3.25	2.00	1.63	2.93	5.87	4.65	7.93	10.53	4.00	11.28	2.93	0.312-18	0.62
918-913	5.56	3.69	4.19	2.75	2.09	3.69	6.50	5.75	8.24	10.84	4.31	12.57	3.27	0.312-18	0.75
921-913	6.06	3.81	5.00	2.88	2.50	4.10	6.85	6.38	8.62	11.22	4.69	13.16	3.37	0.375-16	0.75
924-913	6.44	4.06	5.00	2.88	2.50	4.44	7.04	6.94	9.02	11.62	5.09	13.53	3.40	0.375-16	0.75
924-918	6.44	4.06	5.00	2.88	2.50	4.44	7.44	6.94	9.78	12.59	5.09	13.94	3.81	0.375-16	0.75
926-913	7.38	4.44	6.38	3.38	3.19	5.06	7.44	8.00	9.56	12.15	5.62	14.42	3.77	0.375-16	0.75
926-918	7.38	4.44	6.38	3.38	3.19	5.06	7.85	8.00	10.31	13.12	5.62	14.83	4.19	0.375-16	0.75
930-918	8.25	5.06	7.00	4.00	3.50	5.63	8.25	8.88	11.44	14.12	6.75	15.69	4.38	0.375-16	0.75
932-918	8.92	5.88	7.50	4.00	3.75	5.88	8.67	9.38	11.75	14.56	7.06	16.54	4.38	0.437-14	0.88
938-924	10.00	6.37	8.50	4.75	4.25	6.56	9.86	10.44	13.00	15.69	7.75	18.88	5.19	0.500-13	0.75

Size	Output Shaft				Motor Size Available		Approximate Weight Lbs.	Approximate Oil Capacity 1st Stage (oz.)	Approximate Oil Capacity 2nd Stage (oz.)
	U +0.000 -0.001	V	W-Key		Quill Type L	Coupling Type L ₁			
			Sq.	Lgth.					
913-913	0.625	2.19	0.187	1.00	B5	B5, B7	27	6.5	6.5
918-913	0.875	2.06	0.187	1.00	B5	B5, B7	36	6.5	14.0
921-913	1.000	2.38	0.250	1.25	B5	B5, B7	43	6.5	17.5
924-913	1.125	2.66	0.250	1.25	B5	B5, B7	49	6.5	26.5
924-918	1.125	2.66	0.250	1.25	B5, B7	B5, B7	57	14.0	26.5
926-913	1.125	2.78	0.250	2.00	B5	B5, B7	63	6.5	32.0
926-918	1.125	2.78	0.250	2.00	B5, B7	B5, B7	71	14.0	32.0
930-918	1.937	3.64	0.250	2.25	B5, B7	B5, B9	82	14.0	65.0
932-918	1.375	3.44	0.312	2.50	B5, B7	B5, B7	106	14.0	67.0
938-924	1.625	3.81	0.375	2.75	B5, B7, B9	B5, B7, B9	166	26.5	88.0

Rating Information Pages 56 - 65

Motor Information			
Coupling/ Worm Bore Size Designation	NEMA Design	Bore +0.002 -0.000	Key Way
B5	56C	0.625	0.187 x 0.093
B7	140C	0.875	0.187 x 0.093

Coupling/ Worm Bore Size Designation	AJ	AK	BD	BF
B5	5.875	4.50	6.50	0.406
B7	5.875	4.50	6.50	0.406

Assembly Types

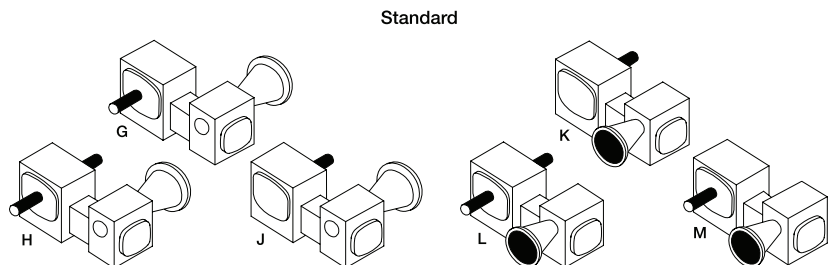

Style FDA & LFDA
With Horizontal Base
Position A

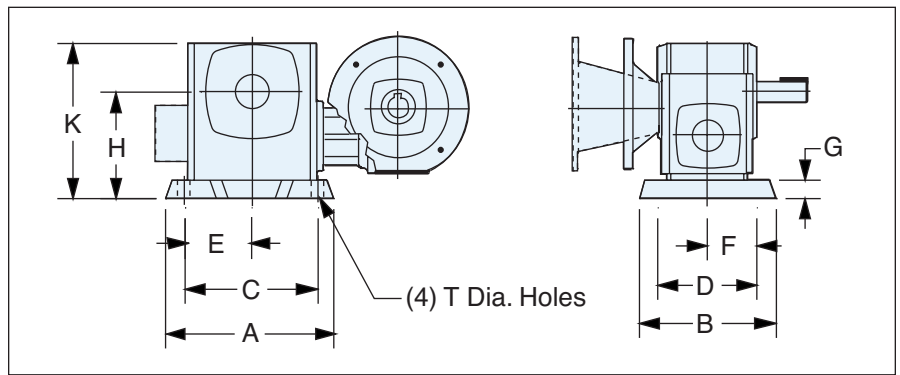

Size	A	B	C	D	E	F	G	H	K	T
913-913	5.38	4.19	4.38	3.31	2.19	1.66	0.53	3.46	5.18	0.343
918-913	7.00	5.69	5.75	4.50	2.88	2.25	0.69	4.38	6.44	0.406
921-913	7.75	5.94	6.38	4.69	3.19	2.34	0.72	4.82	7.10	0.468
924-913	8.50	6.19	7.06	4.88	3.53	2.44	0.75	5.19	7.69	0.468
924-918	8.50	6.19	7.06	4.88	3.53	2.44	0.75	5.19	7.69	0.468
926-913	9.63	6.66	8.00	5.25	4.00	2.63	0.75	5.81	8.75	0.531
926-918	9.63	6.66	8.00	5.25	4.00	2.63	0.75	5.81	8.75	0.531
930-918	10.00	7.50	8.44	5.88	4.22	2.94	0.69	6.32	9.63	0.468
932-918	11.19	7.66	9.50	6.12	4.75	3.06	0.88	6.75	10.25	0.531
938-924	12.13	8.66	10.38	7.00	5.19	3.50	0.94	7.50	11.82	0.593

Rating Information Pages 56 - 65

Style FDA & LFDA
With Vertical Base
Position C/D

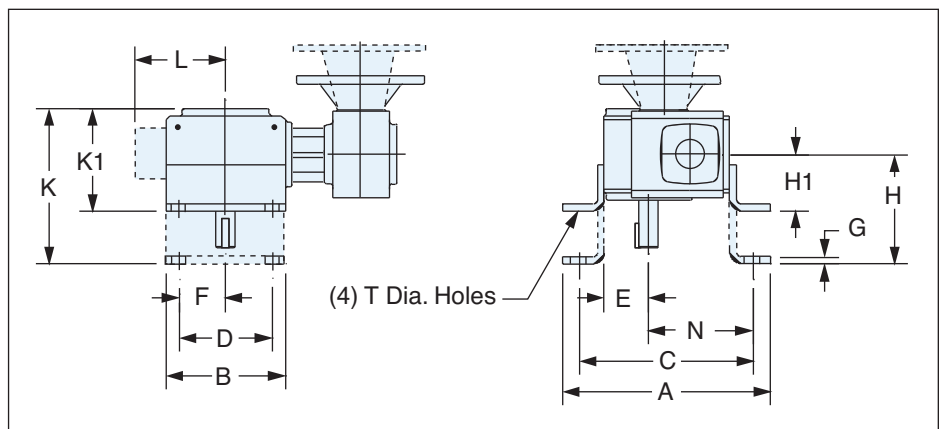

Size	A	B	C	D	E	F	G	H	H ₁	K	K ₁	L	N	T
913-913	7.10	4.12	6.15	3.25	1.72	1.63	0.25	3.56	2.31	5.38	4.13	—	3.68	0.343
918-913	8.43	5.16	7.38	4.00	2.06	2.00	0.25	4.38	3.00	6.63	5.25	—	4.50	0.406
921-913	9.50	6.03	8.38	4.88	2.28	2.44	0.31	4.88	3.13	7.19	5.44	—	5.10	0.468
924-913	10.06	6.31	8.94	4.88	2.50	2.44	0.31	5.25	3.38	7.69	5.81	—	5.44	0.468
924-918	10.06	6.31	8.94	4.88	2.50	2.44	0.31	5.25	3.38	7.69	5.81	—	5.44	0.468
926-913	11.68	7.38	10.13	5.75	2.94	2.88	0.31	5.59	3.63	8.44	6.47	—	6.13	0.531
926-918	11.68	7.38	10.13	5.75	2.94	2.88	0.31	5.59	3.63	8.44	6.47	—	6.13	0.531
930-918	12.50	8.25	11.13	6.00	3.25	3.00	0.38	5.88	3.94	9.00	7.06	—	6.75	0.531
932-918	13.38	9.00	11.88	6.12	3.50	3.06	0.38	6.25	4.69	9.88	8.31	6.65	7.13	0.531
938-924	15.70	10.00	13.94	8.00	3.97	4.00	0.94	7.00	5.25	10.96	9.21	7.34	8.32	0.531

Rating Information Pages 56 - 65

Style FDB Style LFDB

Basic



900 Series Dimensions Double Reduction Flanged Quill/Coupling Type

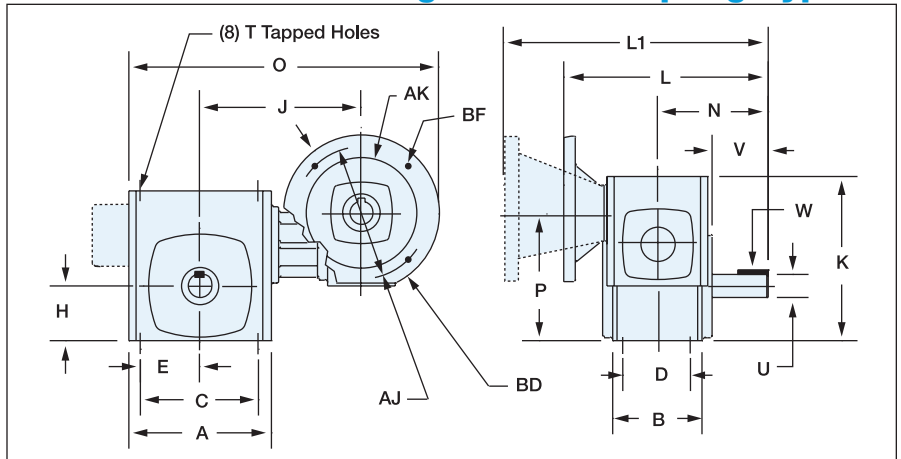

Size	A	B	C	D	E	H	J	K	L	L ₁	N	O	P	T	
														Tap Size	Depth
913-913	4.31	2.88	3.25	2.00	1.63	1.72	5.87	5.98	7.93	10.53	4.00	11.28	4.39	5/16-18	0.62
918-913	5.56	3.69	4.19	2.75	2.09	2.06	6.50	6.74	8.24	10.84	4.31	12.57	5.15	5/16-18	0.62
921-913	6.06	3.81	5.00	2.88	2.50	2.28	6.85	7.27	8.62	11.22	4.69	13.16	5.68	3/8-16	0.75
924-913	6.44	4.06	5.00	2.88	2.50	2.50	7.04	7.80	9.02	11.62	5.09	13.53	6.21	3/8-16	0.75
924-918	6.44	4.06	5.00	2.88	2.50	2.50	7.44	8.56	9.78	12.59	5.09	13.94	6.63	3/8-16	0.75
926-913	7.38	4.44	6.38	3.38	3.19	2.94	7.44	8.49	9.56	12.15	5.62	14.42	6.90	3/8-16	0.75
926-918	7.38	4.44	6.38	3.38	3.19	2.94	7.85	9.25	10.31	13.12	5.62	14.83	7.32	3/8-16	0.75
930-918	8.25	5.06	7.00	4.00	3.50	3.25	8.25	9.94	11.44	14.25	6.75	15.69	8.00	7/16-14	0.88
932-918	8.92	5.88	7.50	4.00	3.75	3.50	8.67	10.44	11.75	14.56	7.06	16.54	8.50	7/16-14	0.88
938-924	10.00	6.37	8.50	4.75	4.25	3.88	9.86	12.06	13.00	15.69	7.75	18.88	10.00	1/2-13	0.75

Size	Output Shaft				Motor Size Available		Approximate Weight Lbs.	Approximate Oil Capacity 1st Stage (oz.)	Approximate Oil Capacity 2nd Stage (oz.)
	U +0.000 -0.001	V	W-Key		Quill Type L	Coupling Type L ₁			
			Sq.	Lgth.					
913-913	0.625	2.19	0.187	1.00	B5	B5, B7	27	6.5	6.5
918-913	0.875	2.06	0.187	1.00	B5	B5, B7	36	6.5	14.0
921-913	1.000	2.38	0.250	1.25	B5	B5, B7	43	6.5	17.5
924-913	1.125	2.66	0.250	1.25	B5	B5, B7	49	6.5	26.5
924-918	1.125	2.66	0.250	1.25	B5, B7	B5, B7	57	14.0	26.5
926-913	1.125	2.78	0.250	2.00	B5	B5, B7	63	6.5	32.0
926-918	1.125	2.78	0.250	2.00	B5, B7	B5, B7	71	14.0	32.0
930-918	1.250	3.63	0.250	2.25	B5, B7	B5, B7	82	14.0	65.0
932-918	1.375	3.44	0.312	2.50	B5, B7	B5, B7	106	14.0	67.0
938-924	1.625	3.81	0.375	2.75	B5, B7, B9	B5, B7, B9	166	26.5	88.0

Rating Information Pages 56 - 65

Motor Information			
Coupling/ Worm Bore Size Designation	NEMA Design	Bore +0.002 -0.000	Key Way
B5	56C	0.625	0.187 x 0.093
B7	140C	0.875	0.187 x 0.093

Coupling/ Worm Bore Size Designation	AJ	AK	BD	BF
B5	5.875	4.50	6.50	0.406
B7	5.875	4.50	6.50	0.406

Assembly Types

Standard

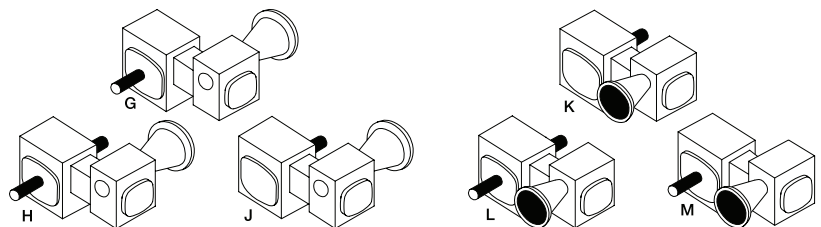

Style FDB & LFDB With Horizontal Base Position B

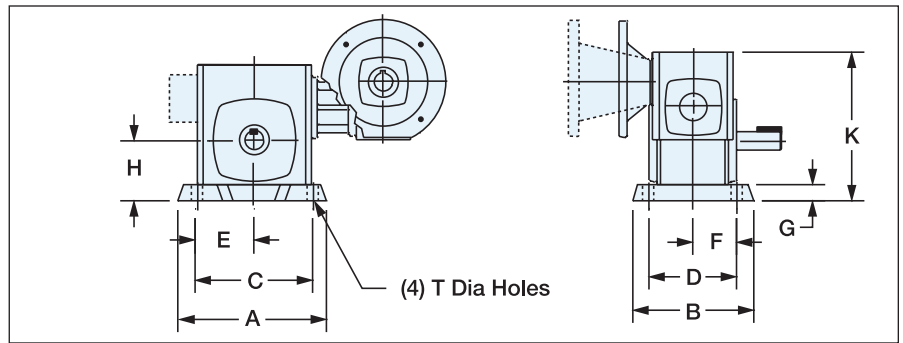

Size	A	B	C	D	E	F	G	H	K	T
913-913	5.38	4.19	4.38	3.31	2.19	1.66	0.53	2.25	6.51	0.343
918-913	7.00	5.69	5.75	4.50	2.88	2.25	0.69	2.75	7.43	0.406
921-913	7.75	5.94	6.38	4.69	3.19	2.34	0.72	3.00	7.99	0.468
924-913	8.50	6.19	7.06	4.88	3.53	2.44	0.75	3.25	8.55	0.468
924-918	8.50	6.19	7.06	4.88	3.53	2.44	0.75	3.25	9.31	0.468
926-913	9.63	6.66	8.00	5.25	4.00	2.63	0.75	3.69	9.24	0.531
926-918	9.63	6.66	8.00	5.25	4.00	2.63	0.75	3.69	10.00	0.531
930-918	10.00	7.50	8.44	5.88	4.22	2.94	0.69	4.00	10.63	0.468
932-918	11.19	7.66	9.50	6.12	4.75	3.06	0.88	4.38	11.32	0.531
938-924	12.13	8.66	10.38	7.00	5.19	3.50	0.94	4.82	13.00	0.593

Rating Information Pages 56 - 65

Style FDB & LFDB With Vertical Base Position C/D

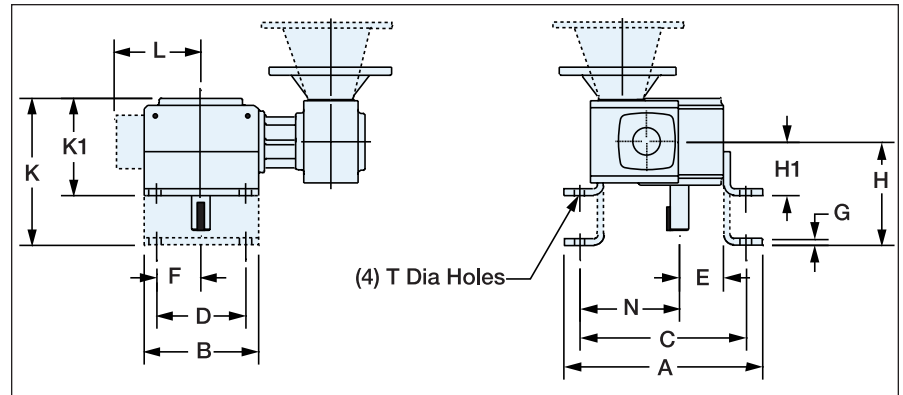

Size	A	B	C	D	E	F	G	H	H ₁	K	K ₁	L	N	T
913-913	7.10	4.12	6.15	3.25	1.72	1.63	0.25	3.56	2.31	5.38	4.13	—	3.68	0.343
918-913	8.43	5.16	7.38	4.00	2.06	2.00	0.25	4.38	3.00	6.63	5.25	—	4.50	0.406
921-913	9.50	6.03	8.38	4.88	2.28	2.44	0.31	4.88	3.13	7.19	5.44	—	5.10	0.468
924-913	10.06	6.31	8.94	4.88	2.50	2.44	0.31	5.25	3.38	7.69	5.81	—	5.44	0.468
924-918	10.06	6.31	8.94	4.88	2.50	2.44	0.31	5.25	3.38	7.69	5.81	—	5.44	0.468
926-913	11.68	7.38	10.13	5.75	2.94	2.88	0.31	5.59	3.63	8.44	6.47	—	6.13	0.531
926-918	11.68	7.38	10.13	5.75	2.94	2.88	0.31	5.59	3.63	8.44	6.47	—	6.13	0.531
930-918	12.50	8.25	11.13	6.00	3.25	3.00	0.38	5.88	3.94	9.00	7.06	—	6.75	0.531
932-918	13.38	9.00	11.88	6.12	3.50	3.06	0.38	6.25	4.69	9.88	8.31	6.89	7.13	0.531
938-924	15.70	10.00	13.94	8.00	3.97	4.00	0.94	7.00	5.25	10.96	9.21	7.34	8.32	0.531

Rating Information Pages 56 - 65

H50
Reducer

900 Series
Single Reduction

900 Series
Double Reduction

Accessories

Ratio Multiplier

In-Line Helical (L-H)

Universal Series
Single Reduction

Universal Series
Double Reduction

Engineering

**Style FDC
Style LFDC**

Basic

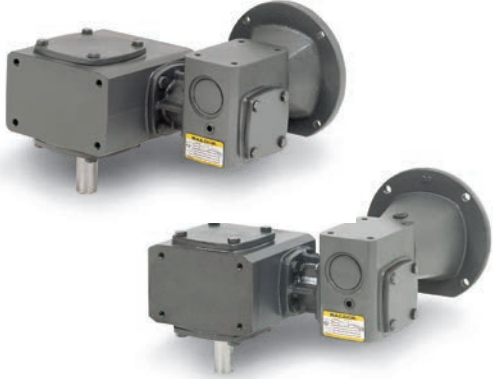

**900 Series Dimensions
Double Reduction Flanged Quill/Coupling Type**

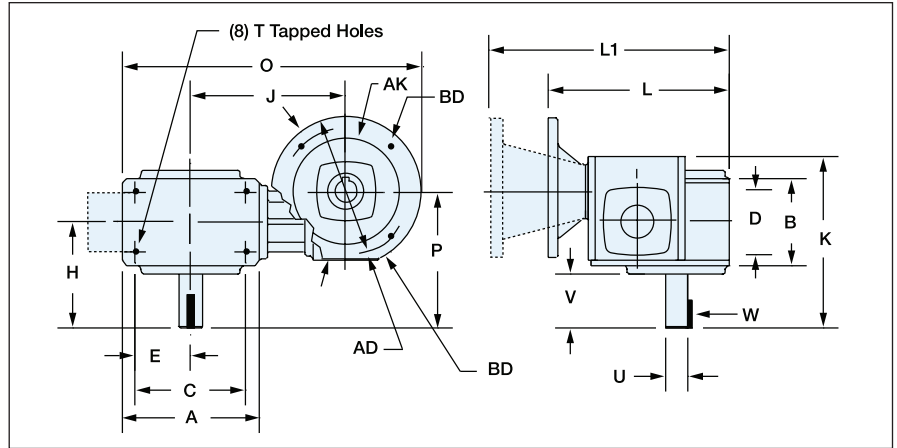

Size	A	B	C	D	E	H	J	K	L	L ₁	O	P	T	
													Tap Size	Depth
913-913	4.31	2.88	3.25	2.00	1.63	4.00	5.87	6.93	6.99	9.58	11.28	5.33	0.312-18	0.62
918-913	5.56	3.69	4.19	2.75	2.09	4.31	6.50	7.24	7.75	10.34	12.57	5.64	0.312-18	0.62
921-913	6.06	3.81	5.00	2.88	2.50	4.69	6.85	7.62	8.28	10.87	13.16	6.02	0.375-16	0.75
924-913	6.44	4.06	5.00	2.88	2.50	5.09	7.04	8.02	8.81	11.40	13.53	6.42	0.375-16	0.75
924-918	6.44	4.06	5.00	2.88	2.50	5.09	7.44	8.78	9.56	12.38	13.94	6.84	0.375-16	0.75
926-913	7.38	4.44	6.38	3.38	3.19	5.62	7.44	8.55	9.50	12.09	14.42	6.95	0.375-16	0.75
926-918	7.38	4.44	6.38	3.38	3.19	5.62	7.85	9.31	10.25	13.06	14.83	7.37	0.375-16	0.75
930-918	8.25	5.06	7.00	4.00	3.50	6.75	8.25	10.44	10.94	13.75	15.69	8.50	0.437-14	0.88
932-918	8.92	5.88	7.50	4.00	3.75	7.06	8.67	10.75	11.44	14.25	16.54	8.81	0.437-14	0.88
938-924	10.00	6.37	8.50	4.75	4.25	7.75	9.86	12.19	12.88	15.57	18.88	10.12	0.500-13	0.75

Size	Output Shaft				Motor Size Available		Approximate Weight (lbs.)	Approximate Oil Capacity 1st Stage (oz.)	Approximate Oil Capacity 2nd Stage (oz.)
	U +.000 -.001	V	W-Key		Quill Type (L)	Coupling Type (L ₁)			
			Sq.	Lgth.					
913-913	0.625	2.19	0.187	1.00	B5	B5, B7	27	6.5	6.5
918-913	0.875	2.06	0.187	1.00	B5	B5, B7	36	6.5	14.0
921-913	1.000	2.38	0.250	1.25	B5	B5, B7	43	6.5	17.5
924-913	1.125	2.66	0.250	1.25	B5	B5, B7	49	6.5	26.5
924-918	1.125	2.66	0.250	1.25	B5, B7	B5, B7	57	14.0	26.5
926-913	1.125	2.78	0.250	2.00	B5	B5, B7	63	6.5	32.0
926-918	1.125	2.78	0.250	2.00	B5, B7	B5, B7	71	14.0	32.0
930-918	1.250	3.64	0.250	2.25	B5, B7	B5, B7	82	14.0	65.0
932-918	1.375	3.44	0.312	2.50	B5, B7	B5, B7	106	14.0	67.0
938-924	1.625	3.81	0.375	2.75	B5, B7, B9	B5, B7, B9	144	26.5	88.0

Rating Information Pages 56 - 65

Motor Information			
Coupling/ Worm Bore Size Designation	NEMA Design	Bore +0.002 -0.000	Key Way
B5	56C	0.625	0.187 x 0.093
B7	140TC	0.875	0.187 x 0.093
B9	180TC	1.125	0.250 x 0.125

Coupling/ Worm Bore Size Designation	AJ	AK	BD	BF
B5	5.875	4.50	6.50	0.406
B7	5.875	4.50	6.50	0.406

Assembly Types

Standard

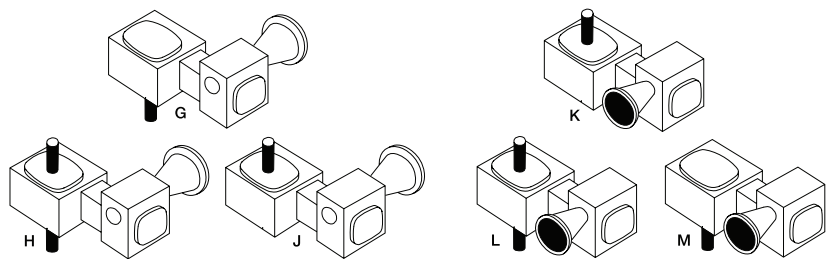

HFO Reducer

900 Series Single Reduction

900 Series Double Reduction

Accessories

Ratio Multipliers

In-Line Helical (LH)

Universal Series Single Reduction

Universal Series Double Reduction

Engineering

Style FDC & LFDC

With Vertical Base

Position C/D

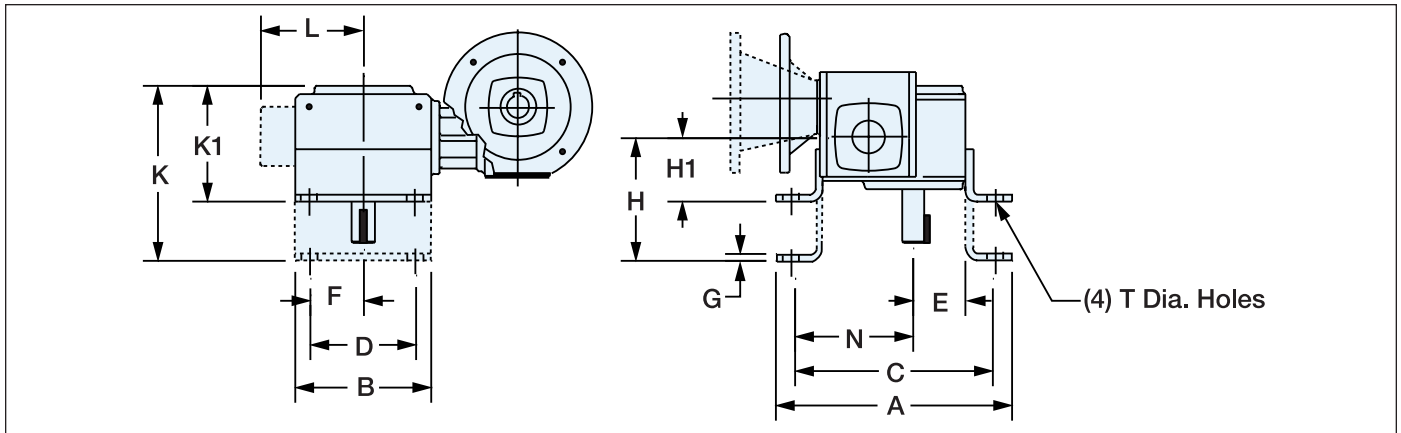

Size	A	B	C	D	E	F	G	H	H ₁	K	K ₁	L	N	T
913-913	7.10	4.12	6.15	3.25	1.72	1.63	0.25	3.56	2.31	5.38	4.13	—	3.68	0.343
918-913	8.43	5.16	7.38	4.00	2.06	2.00	0.25	4.38	3.00	6.63	5.25	—	4.50	0.406
921-913	9.50	6.03	8.38	4.88	2.28	2.44	0.31	4.88	3.13	7.19	5.44	—	5.10	0.468
924-913	10.06	6.31	8.94	4.88	2.50	2.44	0.31	5.25	3.38	7.69	5.81	—	5.44	0.468
924-918	10.06	6.31	8.94	4.88	2.50	2.44	0.31	5.25	3.38	7.69	5.81	—	5.44	0.468
926-913	11.68	7.38	10.13	5.75	2.94	2.88	0.31	5.59	3.63	8.44	6.47	—	6.13	0.531
926-918	11.68	7.38	10.13	5.75	2.94	2.88	0.31	5.59	3.63	8.44	6.47	—	6.13	0.531
930-918	12.88	8.50	11.38	6.12	3.25	3.06	0.81	6.25	4.69	9.36	7.80	—	6.88	0.531
932-918	13.38	9.00	11.88	6.12	3.50	3.06	0.38	6.25	4.69	9.88	8.31	6.65	7.13	0.531
938-924	15.70	10.00	13.94	8.00	3.88	4.00	0.94	7.00	5.25	8.59	6.84	7.39	8.31	0.598

Rating Information Pages 56 - 65

H50
Reducer

900 Series
Single Reduction

900 Series
Double Reduction

Accessories

Ratio Multiplier

In-Line Helical (LH)

Universal Series
Single Reduction

Universal Series
Double Reduction

Engineering

Style DA
Basic

900 Series Dimensions
Double Reduction Solid Worm Type

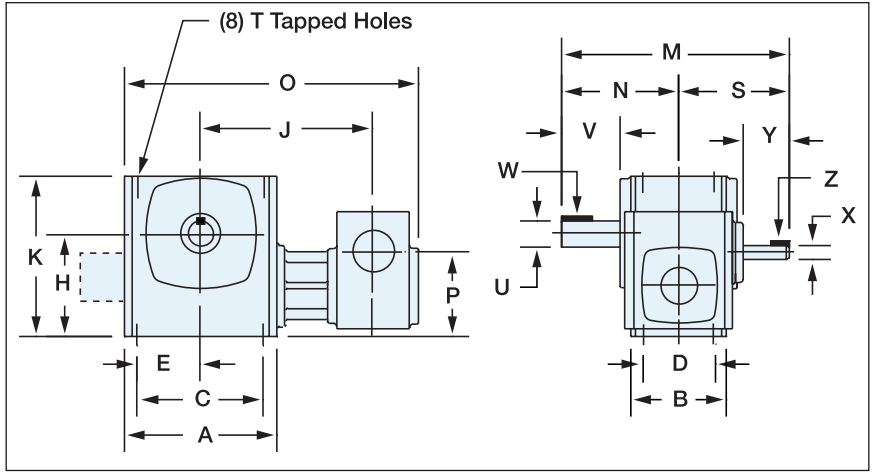
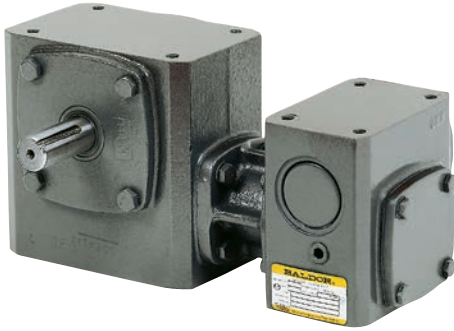

Size	A	B	C	D	E	H	J	K	M	N	O	P	S	T	
														Tap Size	Depth
913-913	4.31	2.88	3.25	2.00	1.63	2.93	5.87	4.65	7.91	4.00	9.84	2.93	3.91	0.312-18	0.62
918-913	5.56	3.69	4.19	2.75	2.09	3.69	6.50	5.75	8.22	4.31	11.13	3.27	3.91	0.312-18	0.62
921-913	6.06	3.81	5.00	2.88	2.50	4.10	6.85	6.38	8.60	4.69	11.72	3.37	3.91	0.375-16	0.75
924-913	6.44	4.06	5.00	2.88	2.50	4.44	7.04	6.94	9.00	5.09	12.10	3.40	3.91	0.375-16	0.75
924-918	6.44	4.06	5.00	2.88	2.50	4.44	7.44	6.94	9.97	5.09	12.94	3.81	4.88	0.375-16	0.75
926-913	7.38	4.44	6.38	3.38	3.19	5.06	7.44	8.00	9.53	5.62	12.98	3.77	3.91	0.375-16	0.75
926-918	7.38	4.44	6.38	3.38	3.19	5.06	7.85	8.00	10.50	5.62	13.92	4.19	4.88	0.375-16	0.75
930-918	8.25	5.06	7.00	4.00	3.50	5.63	8.25	8.88	11.63	6.75	14.62	4.38	4.88	0.437-14	0.88
932-918	8.92	5.88	7.50	4.00	3.75	5.88	8.67	9.38	11.94	7.06	17.80	4.38	4.88	0.437-14	0.88
938-924	10.00	6.37	8.50	4.75	4.25	6.56	9.86	10.44	13.50	7.75	19.63	5.19	5.75	0.500-13	

Size	Output Shaft				Input Shaft				Approximate Weight Lbs.	Approximate Oil Capacity 1st Stage (oz.)	Approximate Oil Capacity 2nd Stage (oz.)
	U +0.000 -0.001	V	W-Key		X +0.000 -0.001	Y	Z-Key				
			Sq.	Lgth.			Sq.	Lgth.			
913-913	0.625	2.19	0.187	1.00	0.500	1.34	0.125	0.62	26	6.5	6.5
918-913	0.875	2.06	0.187	1.00	0.500	1.34	0.125	0.62	35	6.5	14.0
921-913	1.000	2.38	0.250	1.25	0.500	1.34	0.125	0.62	42	6.5	17.5
924-913	1.125	2.66	0.250	1.25	0.500	1.34	0.125	0.62	48	6.5	26.5
924-918	1.125	2.66	0.250	1.25	0.625	1.69	0.187	1.25	56	14.0	26.5
926-913	1.125	2.78	0.250	2.00	0.500	1.34	0.125	0.62	62	6.5	32.0
926-918	1.125	2.78	0.250	2.00	0.625	1.69	0.187	1.25	70	14.0	32.0
930-918	1.250	3.64	0.312	2.50	0.625	1.69	0.187	1.25	84	14.0	65.0
932-918	1.375	3.44	0.312	2.50	0.625	1.69	0.187	1.25	105	14.0	67.0
938-924	1.625	3.81	0.375	2.75	0.750	2.12	0.187	1.25	136	26.5	88.0

Rating Information Pages 56 - 65

Assembly Types
Standard

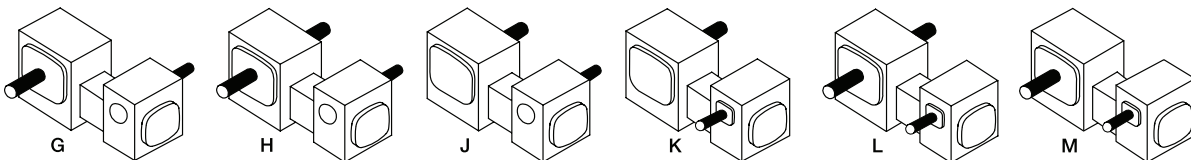

Style DA

With Horizontal Base Position A

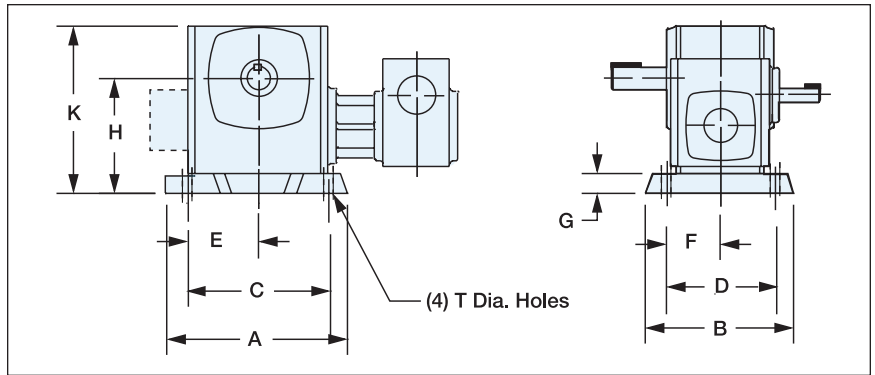

Size	A	B	C	D	E	F	G	H	K	T
913-913	5.38	4.19	4.38	3.31	2.19	1.66	0.53	3.46	5.18	0.343
918-913	7.00	5.69	5.75	4.50	2.88	2.25	0.69	4.38	6.44	0.406
921-913	7.75	5.94	6.38	4.69	3.19	2.34	0.72	4.82	7.10	0.468
924-913	8.50	6.19	7.06	4.88	3.53	2.44	0.75	5.19	7.69	0.468
924-918	8.50	6.19	7.06	4.88	3.53	2.44	0.75	5.19	7.69	0.468
926-913	9.63	6.66	8.00	5.25	4.00	2.63	0.75	5.81	8.75	0.531
926-918	9.63	6.66	8.00	5.25	4.00	2.63	0.75	5.81	8.75	0.531
930-918	10.00	7.50	8.44	5.88	4.22	2.94	0.69	6.32	9.63	0.468
932-918	11.19	7.66	9.50	6.12	4.75	3.06	0.88	6.75	10.25	0.531
938-924	12.13	8.66	10.38	7.00	5.19	3.50	0.94	7.50	11.82	0.593

Rating Information Pages 56 - 65

Style DA

With Vertical Base Position C/D

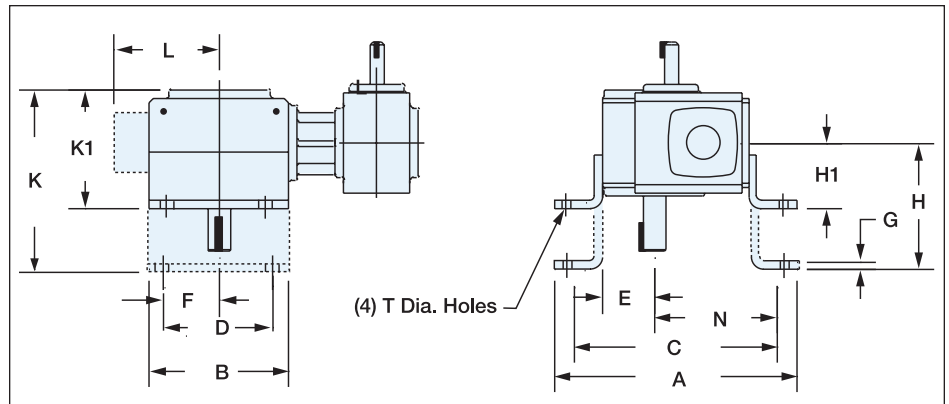

Size	A	B	C	D	E	F	G	H	H ₁	K	K ₁	L	N	T
913-913	7.10	4.12	6.15	3.25	1.72	1.63	0.25	3.56	2.31	5.38	4.13	—	3.68	0.343
918-913	8.43	5.16	7.38	4.00	2.06	2.00	0.25	4.38	3.00	6.63	5.25	—	4.50	0.406
921-913	9.50	6.03	8.38	4.88	2.28	2.44	0.31	4.88	3.13	7.19	5.44	—	5.10	0.468
924-913	10.06	6.31	8.94	4.88	2.50	2.44	0.31	5.25	3.38	7.69	5.81	—	5.44	0.468
924-918	10.06	6.31	8.94	4.88	2.50	2.44	0.31	5.25	3.38	7.69	5.81	—	5.44	0.468
926-913	11.68	7.38	10.13	5.75	2.94	2.88	0.31	5.59	3.63	8.44	6.47	—	6.13	0.531
926-918	11.68	7.38	10.13	5.75	2.94	2.88	0.31	5.59	3.63	8.44	6.47	—	6.13	0.531
930-918	12.50	8.25	11.13	6.00	3.25	3.00	0.38	5.88	3.94	9.00	7.06	—	6.75	0.531
932-918	13.38	9.00	11.88	6.12	3.50	3.06	0.38	6.25	4.69	9.88	8.31	6.89	7.13	0.531
938-924	15.70	10.00	13.94	8.00	3.97	4.00	0.94	7.00	5.25	10.96	9.21	7.34	8.32	0.531

Rating Information Pages 56 - 65

Style DB
Basic

900 Series Dimensions
Double Reduction Solid Worm Type

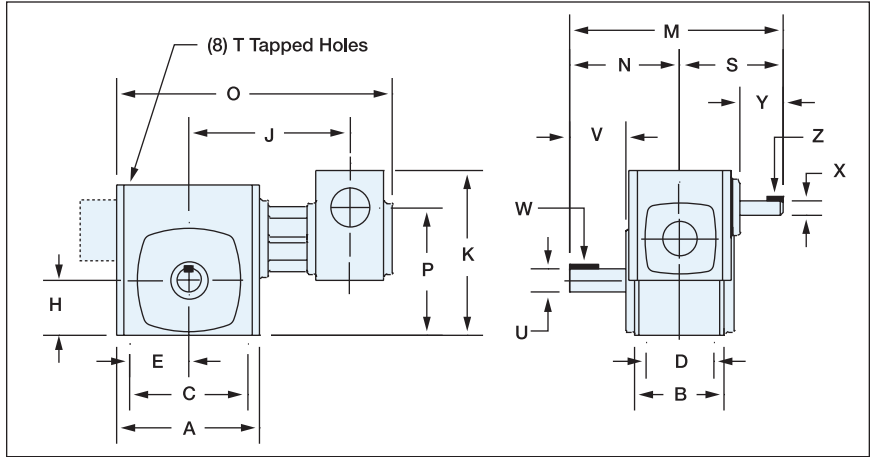

Size	A	B	C	D	E	H	J	K	M	N	O	P	S	T	
														Tap Size	Depth
913-913	4.31	2.88	3.25	2.00	1.63	1.72	5.87	5.98	7.91	4.00	9.84	4.39	3.91	0.312-18	0.62
918-913	5.56	3.69	4.19	2.75	2.09	2.06	6.50	6.74	8.22	4.31	11.13	5.15	3.91	0.312-18	0.62
921-913	6.06	3.81	5.00	2.88	2.50	2.28	6.85	7.27	8.60	4.69	11.72	5.68	3.91	0.375-16	0.75
924-913	6.44	4.06	5.00	2.88	2.50	2.50	7.04	7.80	9.00	5.09	12.10	6.21	3.91	0.375-16	0.75
924-918	6.44	4.06	5.00	2.88	2.50	2.50	7.44	8.56	9.97	5.09	12.94	6.63	4.88	0.375-16	0.75
926-913	7.38	4.44	6.38	3.38	3.19	2.94	7.44	8.49	9.53	5.62	12.98	6.90	3.91	0.375-16	0.75
926-918	7.38	4.44	6.38	3.38	3.19	2.94	7.85	9.25	10.50	5.62	13.92	7.32	4.88	0.375-16	0.75
930-918	8.25	5.06	7.00	4.00	3.50	3.25	8.25	9.94	11.63	6.75	14.62	8.00	4.88	0.437-14	0.88
932-918	8.92	5.88	7.50	4.00	3.75	3.50	8.67	10.44	11.94	7.06	18.94	8.50	4.88	0.437-14	0.88
938-924	10.00	6.37	8.50	4.75	4.25	3.88	9.86	12.06	13.50	7.75	19.63	10.00	5.75	0.500-13	0.75

Size	Output Shaft				Input Shaft				Approximate Weight Lbs.	Approximate Oil Capacity 1st Stage (oz.)	Approximate Oil Capacity 2nd Stage (oz.)
	U +0.000 -0.001	V	W-Key		X +0.000 -0.001	Y	Z-Key				
			Sq.	Lgth.			Sq.	Lgth.			
913-913	0.625	2.19	0.187	1.00	0.500	1.34	0.125	0.62	26	6.5	6.5
918-913	0.875	2.06	0.187	1.00	0.500	1.34	0.125	0.62	35	6.5	14.0
921-913	1.000	2.38	0.250	1.25	0.500	1.34	0.125	0.62	42	6.5	17.5
924-913	1.125	2.66	0.250	1.25	0.500	1.34	0.125	0.62	48	6.5	26.5
924-918	1.125	2.66	0.250	1.25	0.625	1.69	0.187	1.25	56	14.0	26.5
926-913	1.125	2.78	0.250	2.00	0.500	1.34	0.125	0.62	62	6.5	32.0
926-918	1.125	2.78	0.250	2.00	0.625	1.69	0.187	1.25	70	14.0	32.0
930-918	1.250	3.64	0.312	2.50	0.625	1.69	0.187	1.25	84	14.0	65.0
932-918	1.375	3.44	0.312	2.50	0.625	1.69	0.187	1.25	105	14.0	67.0
938-924	1.625	3.81	0.375	2.75	0.750	2.12	0.187	1.25	136	26.5	88.0

Rating Information Pages 56 - 65

Assembly Types
Standard

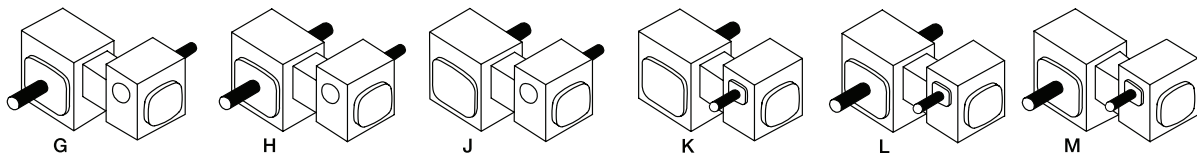

Style DB

With Horizontal Base Position B

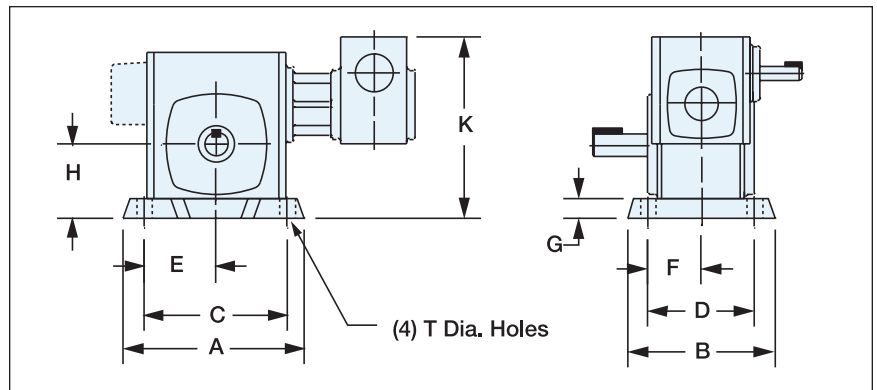

Size	A	B	C	D	E	F	G	H	K	T
913-913	5.38	4.19	4.38	3.31	2.19	1.66	0.53	2.25	6.51	0.343
918-913	7.00	5.69	5.75	4.50	2.88	2.25	0.69	2.75	7.43	0.406
921-913	7.75	5.94	6.38	4.69	3.19	2.34	0.72	3.00	7.99	0.468
924-913	8.50	6.19	7.06	4.88	3.53	2.44	0.75	3.25	8.55	0.468
924-918	8.50	6.19	7.06	4.88	3.53	2.44	0.75	3.25	9.31	0.468
926-913	9.63	6.66	8.00	5.25	4.00	2.63	0.75	3.69	9.24	0.531
926-918	9.63	6.66	8.00	5.25	4.00	2.63	0.75	3.69	10.00	0.531
930-918	10.00	7.50	8.44	5.88	4.22	2.94	0.69	4.00	10.63	0.468
932-918	11.19	7.66	9.50	6.12	4.75	3.06	0.88	4.38	11.32	0.531
938-924	12.13	8.66	10.38	7.00	5.19	3.50	0.94	4.82	13.00	0.593

Rating Information Pages 56 - 65

Style DB

With Vertical Base Position C/D

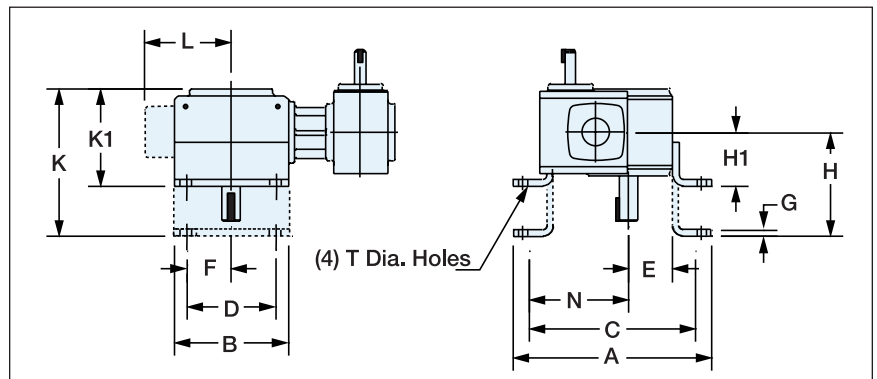

Size	A	B	C	D	E	F	G	H	H ₁	K	K ₁	L	N	T
913-913	7.10	4.12	6.15	3.25	1.72	1.63	0.25	3.56	2.31	5.38	4.13	—	3.68	0.343
918-913	8.43	5.16	7.38	4.00	2.06	2.00	0.25	4.38	3.00	6.63	5.25	—	4.50	0.406
921-913	9.50	6.03	8.38	4.88	2.28	2.44	0.31	4.88	3.13	7.19	5.44	—	5.10	0.468
924-913	10.06	6.31	8.94	4.88	2.50	2.44	0.31	5.25	3.38	7.69	5.81	—	5.44	0.468
924-918	10.06	6.31	8.94	4.88	2.50	2.44	0.31	5.25	3.38	7.69	5.81	—	5.44	0.468
926-913	11.68	7.38	10.13	5.75	2.94	2.88	0.31	5.59	3.63	8.44	6.47	—	6.13	0.531
926-918	11.68	7.38	10.13	5.75	2.94	2.88	0.31	5.59	3.63	8.44	6.47	—	6.13	0.531
930-918	12.50	8.25	11.13	6.00	3.25	3.00	0.38	5.88	3.94	9.00	7.06	—	6.75	0.531
932-918	13.38	9.00	11.88	6.12	3.50	3.06	0.38	6.25	4.69	9.88	8.31	6.65	7.13	0.531
938-924	15.70	10.00	13.94	8.00	3.97	4.00	0.94	7.00	5.25	10.96	9.21	7.34	8.32	0.531

Rating Information Pages 56 - 65

Style DC
Basic

900 Series Dimensions
Double Reduction Solid Worm Type

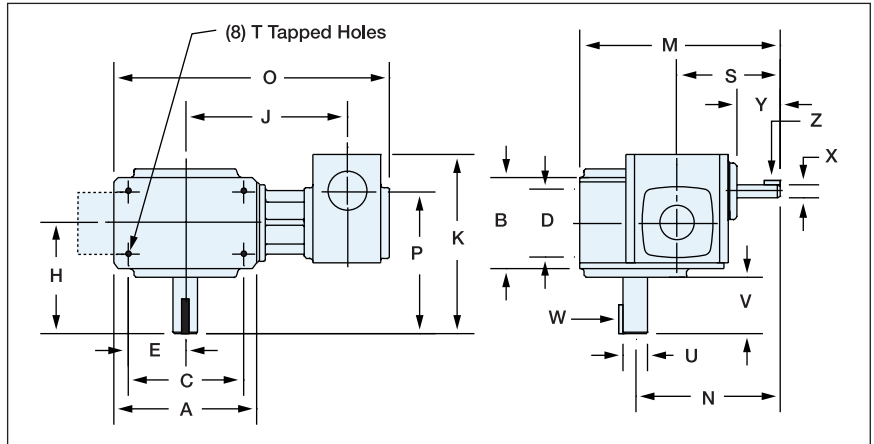
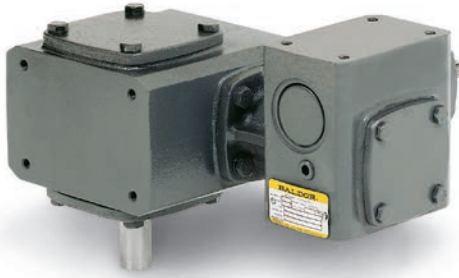

Size	A	B	C	D	E	H	J	K	M	N	O	P	S	T	
														Tap Size	Depth
913-913	4.31	2.88	3.25	2.00	1.63	4.00	5.87	6.93	6.96	5.24	9.84	5.33	3.91	0.312-18	0.62
918-913	5.56	3.69	4.19	2.75	2.09	4.31	6.50	7.24	7.72	5.66	11.13	5.64	3.91	0.312-18	0.62
921-913	6.06	3.81	5.00	2.88	2.50	4.69	6.85	7.62	8.25	5.97	11.72	6.02	3.91	0.375-16	0.75
924-913	6.44	4.06	5.00	2.88	2.50	5.09	7.04	8.02	8.79	6.29	12.10	6.42	3.91	0.375-16	0.75
924-918	6.44	4.06	5.00	2.88	2.50	5.09	7.44	8.78	9.76	7.26	12.94	6.84	4.88	0.375-16	0.75
926-913	7.38	4.44	6.38	3.38	3.19	5.62	7.44	8.55	9.47	6.54	12.98	6.95	3.91	0.375-16	0.75
926-918	7.38	4.44	6.38	3.38	3.19	5.62	7.85	9.31	10.44	7.51	13.92	7.37	4.88	0.375-16	0.75
930-918	8.25	5.06	7.00	4.00	3.50	6.75	8.25	10.44	11.13	7.88	14.62	8.50	4.88	0.437-14	0.88
932-918	8.92	5.88	7.50	4.00	3.75	7.06	8.67	10.75	11.63	8.13	18.94	8.81	4.88	0.437-14	0.88
938-924	10.00	6.37	8.50	4.75	4.25	7.75	9.86	12.19	13.38	9.50	19.63	10.12	5.75	0.500-13	0.75

Size	Output Shaft				Input Shaft				Approximate Weight Lbs.	Approximate Oil Capacity 1st Stage (oz.)	Approximate Oil Capacity 2nd Stage (oz.)
	U +.000 -.001	V	W-Key		X +.000 -.001	Y	Z-Key				
			Sq.	Lgth.			Sq.	Lgth.			
913-913	0.625	2.19	0.187	1.00	0.500	1.34	0.125	0.62	26	6.5	6.5
918-913	0.875	2.06	0.187	1.00	0.500	1.34	0.125	0.62	35	6.5	14.0
921-913	1.000	2.38	0.250	1.25	0.500	1.34	0.125	0.62	42	6.5	17.5
924-913	1.125	2.66	0.250	1.25	0.500	1.34	0.125	0.62	48	6.5	26.5
924-918	1.125	2.66	0.250	1.25	0.625	1.69	0.187	1.25	56	14.0	26.5
926-913	1.125	2.78	0.250	2.00	0.500	1.34	0.125	0.62	62	6.5	32.0
926-918	1.125	2.78	0.250	2.00	0.625	1.69	0.187	1.25	70	14.0	32.0
930-918	1.250	3.64	0.312	2.50	0.625	1.69	0.187	1.25	84	14.0	65.0
932-918	1.375	3.44	0.312	2.50	0.625	1.69	0.187	1.25	105	14.0	67.0
938-924	1.625	3.81	0.375	2.75	0.750	2.12	0.187	1.25	136	26.5	88.0

Rating Information Pages 56 - 65

Assembly Types

Standard

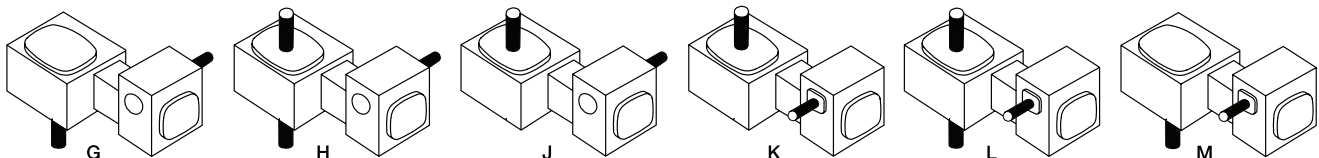

Style DC

With Vertical Base

Position C/D

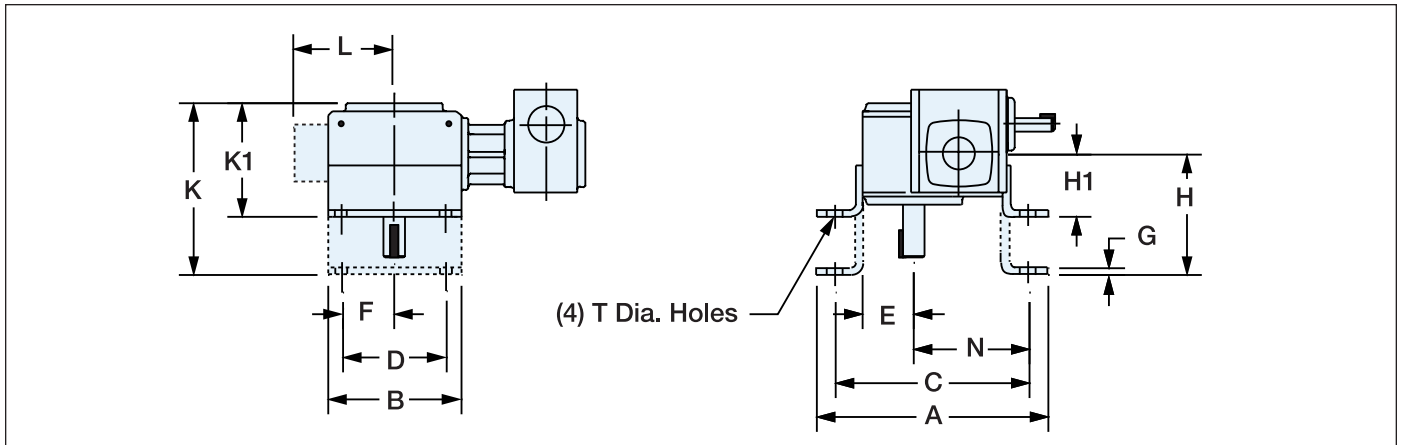

Size	A	B	C	D	E	F	G	H	H1	K	K1	L	N	T
913-913	7.10	4.12	6.15	3.25	1.72	1.63	0.25	3.56	2.31	5.38	4.13	—	3.68	0.343
918-913	8.43	5.16	7.38	4.00	2.06	2.00	0.25	4.38	3.00	6.63	5.25	—	4.50	0.406
921-913	9.50	6.03	8.38	4.88	2.28	2.44	0.31	4.88	3.13	7.19	5.44	—	5.10	0.468
924-913	10.06	6.31	8.94	4.88	2.50	2.44	0.31	5.25	3.38	7.69	5.81	—	5.44	0.468
924-918	10.06	6.31	8.94	4.88	2.50	2.44	0.31	5.25	3.38	7.69	5.81	—	5.44	0.468
926-913	11.68	7.38	10.13	5.75	2.94	2.88	0.31	5.59	3.63	8.44	6.47	—	6.13	0.531
926-918	11.68	7.38	10.13	5.75	2.94	2.88	0.31	5.59	3.63	8.44	6.47	—	6.13	0.531
930-918	12.88	8.50	11.38	6.12	3.25	3.06	0.81	6.25	4.69	9.36	7.80	—	6.88	0.531
932-918	13.38	9.00	11.88	6.12	3.50	3.06	0.38	6.25	4.69	9.88	8.31	6.65	7.13	0.531
938-924	15.70	10.00	13.94	8.00	3.88	4.00	0.94	7.00	5.25	8.59	6.84	7.34	8.31	0.598

Rating Information Pages 56 - 65

H50
Reducer

900 Series
Single Reduction

900 Series
Double Reduction

Accessories

Ratio Multiplier

In-Line Helical (L-H)

Universal Series
Single Reduction

Universal Series
Double Reduction

Engineering

Accessories

H50 Reducer	Precision Shaft Adapter	79
900 Series Single Reduction	LF900 Flange Kits	79
	Double Reduction Kits	79
	900 Horizontal Washdown Bases	80
900 Series Double Reduction	Riser Blocks	80
	Horizontal and Vertical Base Kits	81
Accessories	Torque Arm Kits	82
	Output Flange Kits	82
	Hollow Bore and Stainless Steel Bushing Kits	83

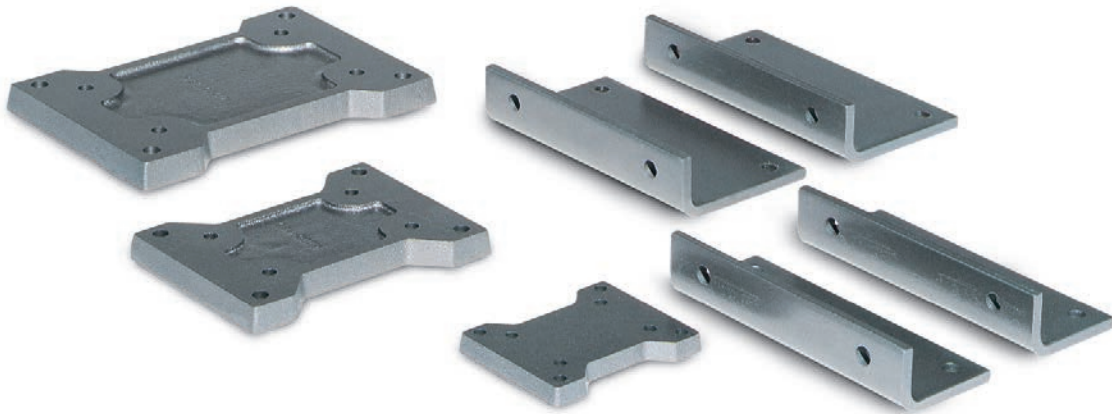

Accessories and Options

7/8 x 5/8 Bushing



Applications: Precision Shaft Adapter for use between a 56C Frame Motor and a "C" Face Input Reducer with a 7/8 dia. Quill Mount.

Description	Catalog Number
Reducer Bushing	133-6FBA

LF900 Series C-Face Kits



Kit adapts NEMA C-Face motors to 900 Series Type S Reducers. Includes flange, flexible coupling and mounting hardware.

Size	NEMA Flange	Catalog Number
913	56C	SFL913B5
915	56C	SFL918B5
	140TC	SFL918B7
918	56C	SFL918B5
	140TC	SFL918B7
921	56C	SFL921B5
	140TC	SFL921B7
924	56C	SFL924B5
	140TC	SFL924B7
	180TC	SFL924B9
926	56C	SFL926B5
	140TC	SFL926B7
	180TC	SFL926B9

Double Reduction Adapter Kits



900 Series Double Reduction units may be assembled from stock single reduction units using the adapter kits.

Catalog Number	Primary Unit (Except shaft mount)	Secondary Unit (F and HF styles only)
DR913X913B5	913	913-B5
DR913X918B5	913	918-B5
DR913X921B5	913	921-B5
DR913X924B5	913	924-B5
DR913X926B5	913	926-B5
DR918X924B7	918	924-B7
DR918X926B7 *	918	926/930-B7
DR918X932B7	918	932-B7
DR924X938B9	924	938-B9

* Also available in Stainless Steel SSDR918X926B7

Each adapter kit consists of: 1 Adapter 4 Screws 1 Bearing Cup (Installed) 4 Lock Washers 1 Seal (Installed) 1 Sealant Package 1 Shim Set

Accessories and Options

900 Series Horizontal Base



900 Series Riser Block Kit



Riser Blocks permit the gearbox to be mounted in the most desirable position (high speed input shaft above the oil level). They mount on top of the gearbox to provide clearance between the motor and the mounting surface. Kit includes the Riser Block and attachment bolts.

Horizontal base sold separately.

Dimension for kits assembled on units are shown on page 33.

Horizontal Bases for 900 Series Washdown Units

Size	Catalog Number
913	WDB13H71
915	WDB15H71
918	WDB18H71
921	WDB21H71
924	WDB24H71
926	WDB26H71
930	WDB30H71
932	WDB32H71

Riser Block Kits for 900 Series Units

Size	Motor Frame	Catalog Number
913	56C	RBK13B5
915	56C / 140TC	RBK15B5
918	56C / 140TC	RBK18B5
921	56C / 140TC	RBK21B5
924	56C / 140TC	RBK24B5
924	180TC	RBK24B9
926	56C / 140TC	RBK26B5
926	180TC	RBK26B9
930	56C / 140TC	RBK30B5
930	180TC	RBK30B9
932	56C / 140TC	RBK32B5
932	180TC	RBK32B9

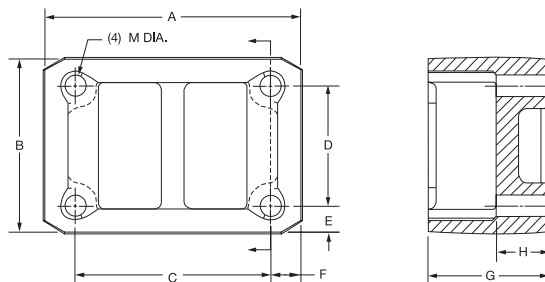

Size	Mtr. Frame	Catalog Number	A	B	C	D	E	F	G	H	M
913	56C	RBK13B5	4.25	2.88	3.25	2.00	0.44	0.50	2.00	0.88	0.36
915	56C/140TC	RBK15B5	5.12	3.69	4.19	2.75	0.47	0.47	1.60	0.88	0.36
918	56C/140TC	RBK18B5	5.50	3.69	4.19	2.75	0.47	0.66	1.69	0.88	0.36
921	56C/140TC	RBK21B5	6.00	3.81	5.00	2.88	0.47	0.50	1.53	0.88	0.42
924	56C/140TC	RBK24B5	6.38	4.06	5.00	2.88	0.59	0.69	1.50	0.88	0.42
924	180TC	RBK24B9	6.38	4.06	5.00	2.88	0.59	0.69	3.00	2.38	0.42
926	56C/140TC	RBK26B5	7.38	4.44	6.38	3.38	0.53	0.50	1.25	0.75	0.42
926	180TC	RBK26B9	7.38	4.44	6.38	3.38	0.53	0.50	2.51	2.00	0.42
930	56C/140TC	RBK30B5	8.16	5.29	7.00	4.00	0.65	0.58	1.07	1.07	0.49
930	180TC	RBK30B9	8.16	5.29	7.00	4.00	0.65	0.58	2.13	2.13	0.49
932	56C/140TC	RBK32B5	9.00	5.88	7.50	4.00	0.94	0.75	1.19	0.88	0.49
932	180TC	RBK32B9	9.00	5.88	7.50	4.00	0.94	0.75	2.38	2.07	0.49

HFO Reducer

900 Series Single Reduction

900 Series Double Reduction

Accessories

Ratio Multipliers

In-Line Helical (LH)

Universal Series Single Reduction

Universal Series Double Reduction

Engineering

Accessories and Options

900 Series Horizontal and Vertical Base Kits

HORIZONTAL BASE



VERTICAL LOW BASE



VERTICAL HIGH BASE



VERTICAL J BASE

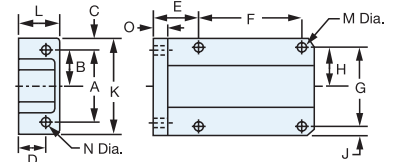
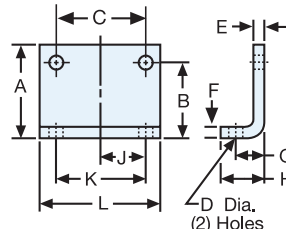
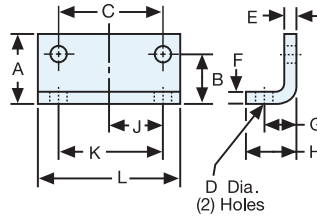
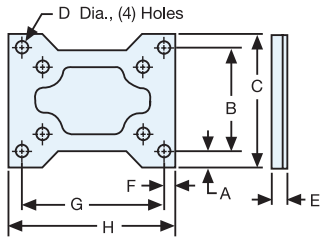

OPTIONAL 900 SERIES HORIZONTAL, VERTICAL AND J BASE KITS

Base Description	Size (Position)	Catalog Number	A	B	C	D	E	F	G	H	J	K	L	M	N	O	Approximate Shipping Weight
HORIZ.	913 (A, B)	B13H71	0.44	3.31	4.19	0.34	0.53	0.50	4.38	5.38	—	—	—	—	—	—	1
VERT., low	913 (D, F)	B13V81	1.75	1.31	2.00	0.34	0.31	0.31	0.75	1.22	1.63	3.25	4.13	—	—	—	2
VERT., high	913 (C, E)	B13V91	3.13	2.56	3.25	0.34	0.31	0.31	0.75	1.22	1.63	3.25	4.13	—	—	—	2
VERT. J	913 (X, Y)	B13J92	2.00	1.00	0.44	0.88	0.85	3.25	2.00	1.00	0.44	2.88	1.31	0.34	0.34	0.53	2
HORIZ.	915 (A, B)	B15H71	0.57	4.31	5.44	0.41	0.60	0.60	5.25	6.44	—	—	—	—	—	—	2
HORIZ.	918 (A, B)	B18H71	0.59	4.50	5.69	0.41	0.69	0.63	5.75	7.00	—	—	—	—	—	—	2
VERT., low	915/918 (D, F)	B18V81	2.13	1.63	2.75	0.41	0.31	0.31	0.81	1.34	2.00	4.00	5.16	—	—	—	3
VERT., high	915/918 (C, E)	B18V91	3.63	3.00	4.19	0.41	0.31	0.31	0.81	1.34	2.00	4.00	5.16	—	—	—	3
VERT. J	915/918 (X, Y)	B18J92	2.15	1.25	0.44	0.94	1.41	4.19	2.75	1.38	0.31	3.38	1.44	0.34	0.41	0.69	3
HORIZ.	921G (A, B)	B21GH71	0.63	4.69	5.94	0.47	0.72	0.69	6.38	7.75	—	—	—	—	—	—	3
HORIZ.	921 (A, B)	B21H71	0.63	4.69	5.94	0.47	0.72	0.69	6.38	7.75	—	—	—	—	—	—	3
VERT., low	921 (D, F)	B21V81	4.13	3.44	2.88	0.47	0.38	0.38	1.00	1.56	2.44	4.88	6.03	—	—	—	3
VERT., high	921 (C, E)	B21V91	4.13	3.44	5.00	0.47	0.38	0.38	1.00	1.56	2.44	4.88	6.03	—	—	—	3
VERT. J	921 (X, Y)	B21J92	2.62	1.31	0.57	1.12	1.44	5.00	2.88	1.44	0.44	3.75	1.69	0.41	0.47	0.72	3
HORIZ.	924 (A, B)	B24H71	0.66	4.88	6.19	0.47	0.75	0.72	7.06	8.50	—	—	—	—	—	—	3
VERT., low	924 (D, F)	B24V81	2.50	1.94	2.88	0.47	0.38	0.38	1.00	1.56	2.44	4.88	6.31	—	—	—	4
VERT., high	924 (C, E)	B24V91	4.50	3.81	5.00	0.47	0.38	0.38	1.00	1.56	2.44	4.88	6.31	—	—	—	4
VERT. J	924 (X, Y)	B24J92	2.88	1.44	0.59	1.12	1.56	5.00	2.88	1.44	0.59	4.06	1.69	0.41	0.47	0.75	4
HORIZ.	926 (A, B)	B26H71	0.70	5.25	6.66	0.53	0.75	0.81	8.00	9.63	—	—	—	—	—	—	4
VERT., low	926 (D, F)	B26V81	2.50	1.94	3.38	0.53	0.38	0.38	1.06	1.84	2.88	5.75	7.38	—	—	—	6
VERT., high	926 (C, E)	B26V91	4.59	3.91	6.38	0.53	0.38	0.38	1.06	1.84	2.88	5.75	7.38	—	—	—	6
VERT. J	926 (X, Y)	B26J92	3.13	1.56	0.66	1.19	1.56	6.38	3.38	1.69	0.53	4.44	1.88	0.41	0.53	0.75	6
HORIZ.	930 (A, B)	B30H71	0.83	5.88	7.54	0.47	0.75	0.89	8.44	10.21	—	—	—	—	—	—	8
VERT. low	930 (D, F)	B30V81	—	—	7.00	0.53	—	0.88	—	—	3.00	6.00	8.25	—	—	—	13
VERT. high	930 (C, E)	B30V91	—	—	7.00	0.53	—	0.88	—	—	3.00	6.00	8.25	—	—	—	16
HORIZ.	932 (A, B)	B32H71	0.77	6.13	7.66	0.53	0.88	0.84	9.50	11.19	—	—	—	—	—	—	10
VERT., low	932 (D, F)	B32V81	3.44	2.69	4.00	0.53	0.50	0.50	1.25	2.00	3.06	6.13	9.00	—	—	—	16
VERT., high	932 (C, E)	B32V91	5.13	4.25	7.50	0.53	0.50	0.50	1.25	2.00	3.06	6.13	9.00	—	—	—	19
VERT. J	932 (X, Y)	*	4.00	2.00	0.50	1.59	1.94	7.50	4.00	2.00	0.50	5.00	2.31	0.47	0.53	0.81	6
HORIZ.	938 (A, B)	B38H71	0.83	6.12	7.78	0.54	0.88	0.89	9.50	11.27	—	—	—	—	—	—	15
VERT., low	938 (D, F)	B38V81	8.44	2.86	8.50	0.60	0.50	0.94	1.75	2.63	4.00	8.00	10.00	—	—	—	25
VERT., high	938 (C, E)	B38V91	10.19	4.63	8.50	0.60	0.50	0.94	1.75	2.63	4.00	8.00	10.00	—	—	—	28

* Vertical J for 932 Part No. HA6622A07SP can be used only if cooling fan is omitted. Unit must be derated 33%.

Accessories and Options

Torque Arm Kits

Kit includes turnbuckle and both mounting brackets.

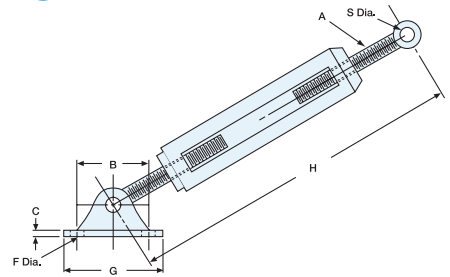

Turn Buckle

Size	Catalog Number	A	B	C	F	G	H (Inches)	S
913	TA13HK	0.500 - 13	2.50	0.18	0.375	3.50	9 - 15	0.53
918	TA18HK	0.500 - 13	2.50	0.18	0.375	3.50	9 - 15	0.53
921	TA21HK	0.625 - 13	2.50	0.18	0.375	3.50	24 - 30	0.53
924	TA24HK	0.625 - 13	2.50	0.18	0.375	3.50	24 - 30	0.53
926	TA26HK	0.625 - 13	2.50	0.18	0.375	3.50	24 - 30	0.53
930	TA30HK	0.625 - 13	2.50	0.18	0.375	3.50	24 - 30	0.53
932	TA32HK	0.625 - 13	2.50	0.18	0.375	3.50	24 - 30	0.53
938	TA38HK	0.625 - 13	2.50	0.18	0.375	3.50	24 - 30	0.53

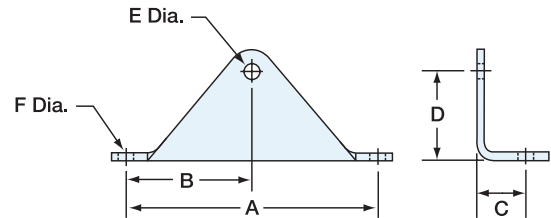

Reducer Mounted Bracket

Size	Catalog Number	A	B	C	D	E	F	Weight (Lbs.)
913	TA13HK	3.25	1.63	0.75	1.22	0.53	0.344	0.6
918	TA18HK	4.19	2.09	0.95	1.38	0.53	0.344	0.9
921	TA21HK	5.00	2.50	1.28	1.97	0.53	0.406	1.0
924	TA24HK	5.00	2.50	1.28	2.25	0.53	0.406	1.2
926	TA26HK	6.38	3.19	1.31	2.38	0.53	0.406	1.4
930	TA30HK	7.00	3.50	1.44	2.62	0.53	0.468	1.7
932	TA32HK	7.50	3.75	1.35	3.19	0.53	0.468	2.0
938	TA38HK	8.50	4.25	1.68	3.00	0.53	0.531	2.5

Output Flange Kits

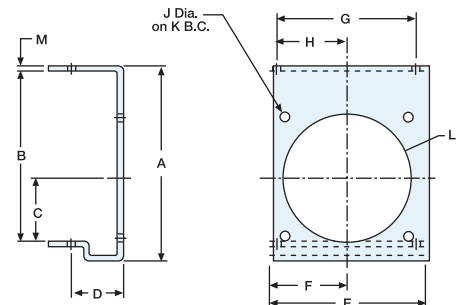

Size	Catalog Number	A	B	C	D	E	F	G	H	J	K	L	M	Weight Lbs.
913	FL13HK	5.56	4.66	1.72	2.00	4.25	2.13	3.25	1.63	.344	5.000	3.63	.19	2.7
915	FL15HK	6.19	5.38	1.91	2.19	4.75	2.38	4.19	2.09	.344	5.000	3.63	.19	3.3
918	FL18HK	6.66	5.75	2.06	2.13	4.81	2.41	4.19	2.09	.344	5.875	4.06	.19	3.4
921	FL21HK	7.43	6.38	2.28	2.31	5.75	2.88	5.00	2.50	.406	6.500	4.50	.19	4.6
924	FL24HK	8.24	6.94	2.50	2.28	6.13	3.06	5.00	2.50	.406	7.500	5.00	.19	5.1
926	FL26HK	9.25	8.00	2.94	2.37	7.18	3.59	6.38	3.19	.406	8.000	6.00	.25	8.4
930	FL30HK	10.02	8.88	3.25	2.50	8.50	4.25	7.00	3.50	.406	9.000	7.00	.25	10.1
932	FL32HK	10.89	9.38	3.50	3.25	8.50	4.25	7.50	3.75	.563	10.000	7.00	.25	11.9
938	FL38HK	11.85	10.44	3.88	3.08	9.54	4.77	8.50	4.25	.563	11.500	8.00	.25	13.3

Accessories and Options

Bushing Kits for Hollow Shaft Reducers



Size	Shaft Diameter	Bushing Kit Number	Size	Shaft Diameter	Bushing Kit Number
918	0.750	BU100H012	924/926	1.250	BU107H104
918	0.875	BU100H014	924/926	1.312	BU107H105
918	0.937	BU100H015	930/932	1.437	BU115H107
921	1.125	BU104H102	930/932	1.500	BU115H108
924/926	0.937	BU107H015	930/932	1.625	BU115H110
924/926	1.000	BU107H100	930/932	1.687	BU115H111
924/926	1.125	BU107H102	930/932	1.750	BU115H112
924/926	1.187	BU107H103			

Stainless Steel Bushing Kits

Size	Shaft Diameter	Bushing Kit Number	Size	Shaft Diameter	Bushing Kit Number
918	0.750	SSBU100H012	926	0.937	SSBU107H015
918	0.875	SSBU100H014	926	1.000	SSBU107H100
918	0.937	SSBU100H015	926	1.125	SSBU107H102
921	0.937	SSBU104H015	926	1.187	SSBU107H103
921	1.000	SSBU104H100	926	1.250	SSBU107H104
921	1.125	SSBU104H102	926	1.312	SSBU107H105

Ratio Multipliers

H50 Reducer	Single Stage Parallel Shaft Gear Reducer	85
900 Series Single Reduction	How to Order	86
	Ratings Tables	87-88
	Dimensions	89
900 Series Double Reduction		
Accessories		
Ratio Multipliers		
In-Line Helical (LH)		
Universal Series Single Reduction		
Universal Series Double Reduction		
Engineering		

Ratio Multiplier

Single Stage Parallel Shaft Gear Reducer

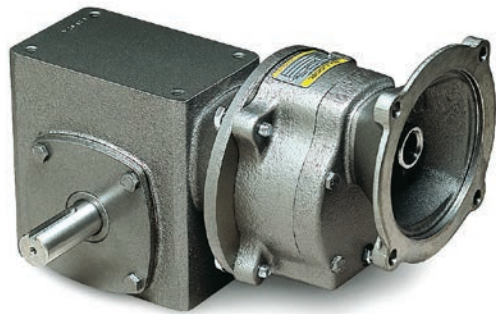
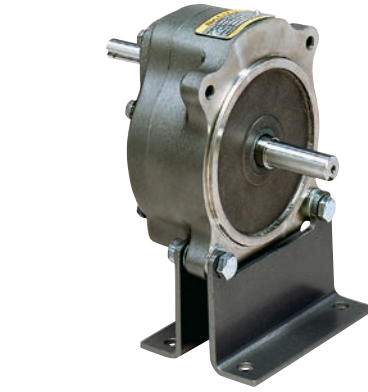

- Reducer or Increaser
- High Efficiency
- 4 Ratios Available
- Shipped with Synthetic Oil
- Optional Base Mounting
- Cast Iron Construction
- Combine with Right Angle Units for High Ratios
- Industry Standard Mountings

H50
Reducer

900 Series
Single Reduction

900 Series
Double Reduction

Accessories

Ratio Multiplier

In-Line Helical (LH)

Universal Series
Single Reduction

Universal Series
Double Reduction

Engineering

Ratio Multiplier Numbering/How to Order

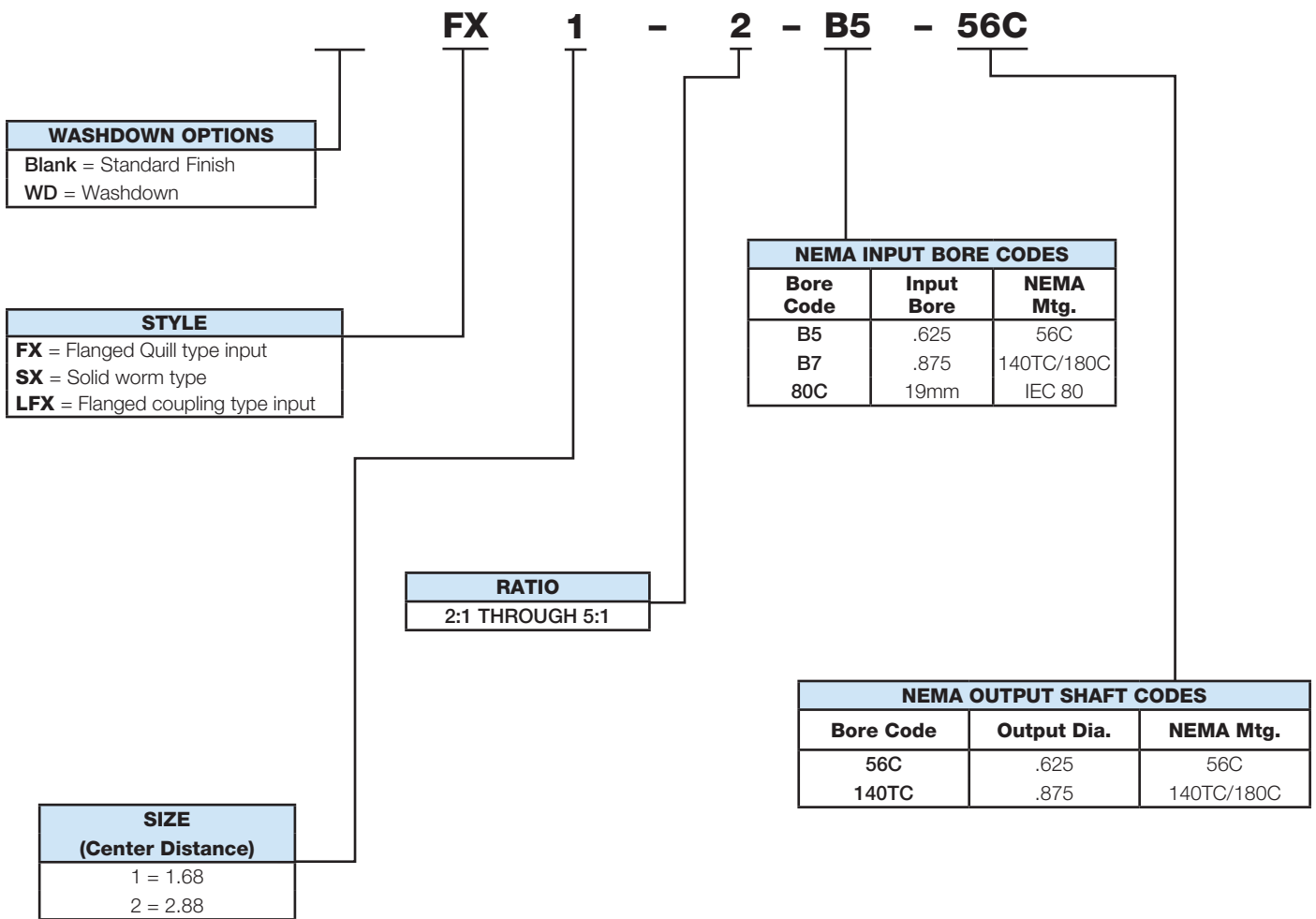

HOW TO ORDER

Please specify Style, Size, Base (if required), Ratio, NEMA Input Flange (if flanged reducer), Output shaft assembly.

NOTE:

SX units only require an output shaft code to be specified. Input and output shaft diameters will be the same unless otherwise specified on the order. Standard lubrication is **not** food grade. Food grade lubrication must be specified in the order notes if required.

RATING EXAMPLES:

FX2-02-B5-140TC
LFX2-05-B7-140TC
SX1-05-56C

Baldor 900 Series Double Reduction Ratio Multiplier/Worm Ratings 1750 RPM Size 1 Ratio Multiplier

Total Ratio	Output RPM	Primary Ratio Size 1 RM	Secondary Ratio Worm	913 SIZE			915 SIZE			918 SIZE			921 SIZE		
				Input HP	Output HP	Output Torque In. Lbs.	Input HP	Output HP	Output Torque In. Lbs.	Input HP	Output HP	Output Torque In. Lbs.	Input HP	Output HP	Output Torque In. Lbs.
10	172.5	2	5	0.645	0.553	202	1.060	0.814	293	1.310	1.133	414	2.058	1.790	654
15	115.0	3	5	0.458	0.392	215	0.770	0.578	312	0.968	0.838	459	1.636	1.423	780
20	86.3	4	5	0.347	0.297	217	0.600	0.447	332	0.736	0.636	465	1.322	1.150	840
25	69.0	5	5	0.281	0.241	220	0.500	0.364	328	0.595	0.515	470	1.133	0.985	900
30	57.5	3	10	0.330	0.251	275	0.470	0.340	367	0.640	0.505	553	0.962	0.775	850
40	43.1	4	10	0.252	0.192	280	0.360	0.260	375	0.491	0.387	565	0.764	0.616	900
45	38.3	3	15	0.251	0.176	290	0.410	0.255	414	0.470	0.348	572	0.728	0.553	910
50	34.5	5	10	0.205	0.156	285	0.310	0.214	386	0.396	0.312	570	0.645	0.520	950
60	28.8	4	15	0.191	0.135	295	0.320	0.198	427	0.355	0.263	577	0.570	0.433	950
75	23.0	5	15	0.148	0.104	285	0.260	0.161	436	0.286	0.212	580	0.471	0.358	980
100	17.3	5	20	0.128	0.082	301	0.200	0.117	422	0.250	0.174	634	0.393	0.276	1010
125	13.8	5	25	0.105	0.066	304	0.170	0.093	417	0.202	0.137	625	0.315	0.224	1025
150	11.5	5	30	0.101	0.057	310	0.150	0.077	416	0.194	0.120	656	0.278	0.177	970
200	8.6	5	40	0.084	0.041	303	0.120	0.058	420	0.155	0.085	624	0.238	0.135	990
250	6.9	5	50	0.068	0.030	275	0.110	0.044	396	0.128	0.063	576	0.193	0.101	920
300	5.8	5	60	0.050	0.023	250	0.090	0.035	376	0.106	0.049	541	0.171	0.081	890

Baldor 900 Series Double Reduction Ratio Multiplier/Worm Ratings 1750 RPM Size 2 Ratio Multiplier

Total Ratio	Output RPM	Primary Ratio Size 2 RM	Secondary Ratio Worm	924 SIZE			926 SIZE			932 SIZE			938 SIZE		
				Input HP	Output HP	Output Torque In. Lbs.	Input HP	Output HP	Output Torque In. Lbs.	Input HP	Output HP	Output Torque In. Lbs.	Input HP	Output HP	Output Torque In. Lbs.
30	57.5	3	10	1.395	1.140	1250	1.814	1.496	1640	3.283	2.745	3009	4.690	3.921	4298
40	43.1	4	10	1.088	0.890	1300	1.411	1.163	1700	2.562	2.142	3130	3.683	3.079	4500
45	38.3	3	15	1.086	0.864	1420	1.321	1.046	1720	2.498	1.994	3278	3.521	2.810	4620
50	34.5	5	10	0.920	0.753	1375	1.202	0.991	1810	2.305	1.927	3521	3.179	2.658	4855
60	28.8	4	15	0.849	0.675	1480	1.103	0.873	1914	1.915	1.528	3350	2.687	2.144	4700
75	23.0	5	15	0.700	0.557	1525	0.857	0.679	1860	1.700	1.356	3717	2.339	1.867	5115
100	17.3	5	20	0.593	0.432	1580	0.738	0.541	1975	1.412	1.076	3930	1.913	1.457	5325
125	13.8	5	25	0.453	0.328	1500	0.539	0.406	1855	1.113	0.833	3805	1.569	1.174	5362
150	11.5	5	30	0.451	0.296	1620	0.640	0.371	2002	1.066	0.741	4062	1.409	0.979	5367
200	8.6	5	40	0.366	0.219	1600	0.453	0.271	1980	0.839	0.536	3914	1.121	0.716	5231
250	6.9	5	50	0.294	0.162	1480	0.364	0.204	1861	0.632	0.379	3458	0.932	0.558	5100
300	5.8	5	60	0.259	0.133	1455	0.308	0.161	1766	0.551	0.304	3331	0.854	0.471	5162

Ratio Multiplier



H50 Reducer

900 Series Single Reduction

900 Series Double Reduction

Accessories

Ratio Multipliers

In-Line Helical (LH)

Universal Series Single Reduction

Universal Series Double Reduction

Engineering

Ratings at 1750 RPM Input

Size	Ratio	Output RPM	Input HP	Output HP	Output Torque In. Lbs.	Thrust Load	Output Shaft OHL
1	2	875	2.00	1.95	141	169	173
	3	583	1.65	1.62	175	193	203
	4	438	1.38	1.35	195	213	224
	5	350	1.10	1.07	194	230	247
2	2	875	12.42	12.17	877	253	445
	3	583	8.68	8.42	911	289	445
	4	438	6.36	6.15	885	319	445
	5	350	5.40	5.17	933	345	360

Catalog Numbers

Size	Output RPM @ 1750 RPM In	Ratio	Input Style	Output Style	Type	Catalog Number	Shipping Weight	Approx. Oil Capacity
1	875	2	56C	56C	FX1-2-B5-56C	GCF2X01AA	19	4.0
	583	3	56C	56C	FX1-3-B5-56C	GCF3X01AA	19	4.0
	438	4	56C	56C	FX1-4-B5-56C	GCF4X01AA	19	4.0
	350	5	56C	56C	FX1-5-B5-56C	GCF5X01AA	19	4.0
2	875	2	140TC	140TC	FX2-2-B7-140TC	GCF2X02BB	22	8.5
	583	3	140TC	140TC	FX2-3-B7-140TC	GCF3X02BB	22	8.5
	438	4	140TC	140TC	FX2-4-B7-140TC	GCF4X02BB	22	8.5
	350	5	56C	140TC	FX2-5-B5-140TC	GCF5X02AB	22	8.5
	350	5	140TC	140TC	FX2-5-B7-140TC	GCF5X02BB	22	8.5

Ratio Multiplier

Style SX

Size 1 and Size 2

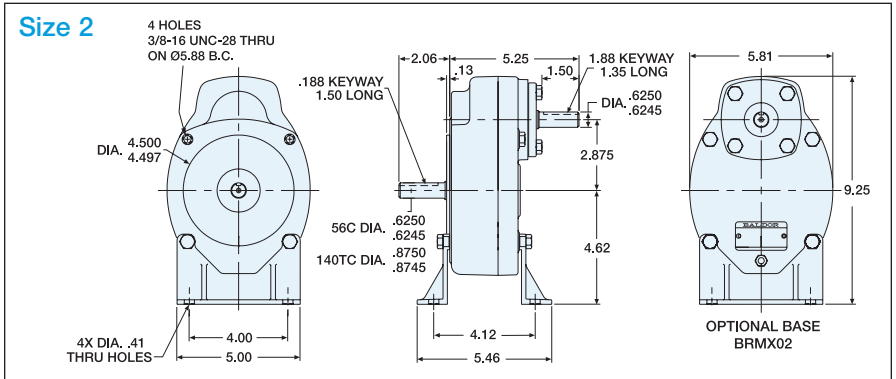
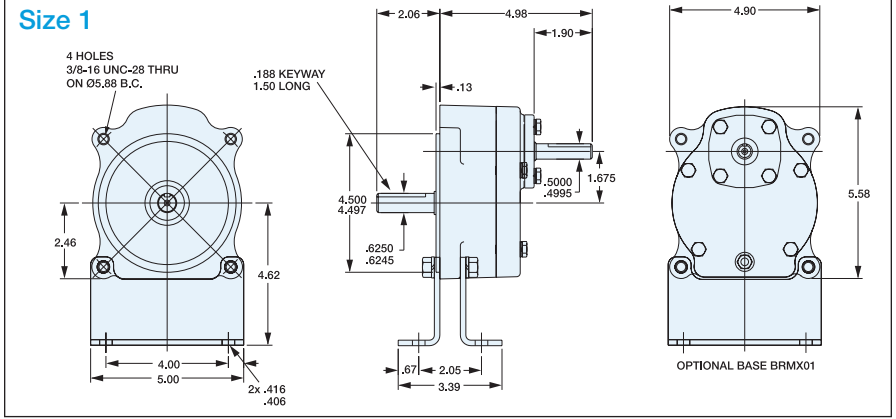

Ratio Multiplier

Style FX

Size 1 and Size 2

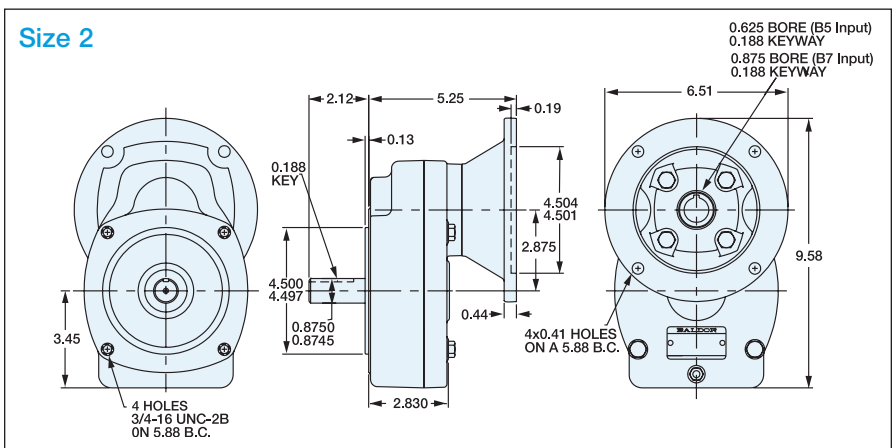
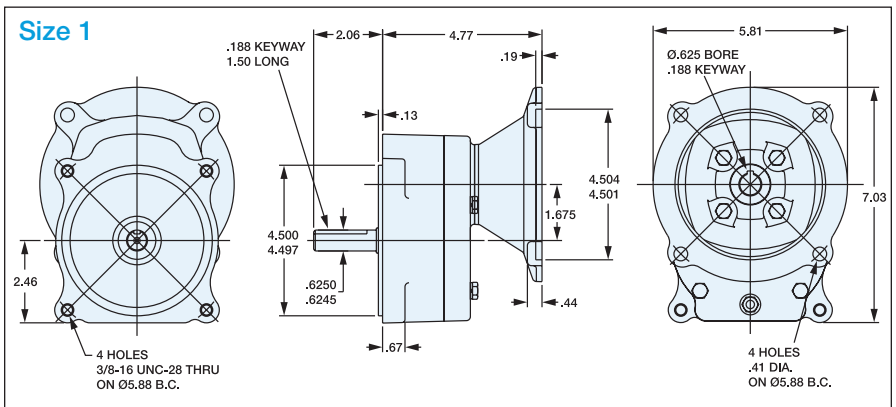

Baldor In-Line Helical C-Face Reducer Sizes 38-88

H50 Reducer
900 Series Single Reduction
900 Series Double Reduction
Accessories
Ratio Multipliers
In-Line Helical (LH)
Universal Series Single Reduction
Universal Series Double Reduction
Engineering

Baldor In-Line Helical C-Face Reducer Sizes 38-88 Features and Benefits	91
How to Order/Selection	92 - 93
How to Order/Service Factor	94 - 96
Nomenclature	97 - 98
Lubrication	99 - 101
Incline Mounting	102
Ratings Tables	103 - 133
Dimensions	134 - 145
Overhung Load/Weights	146

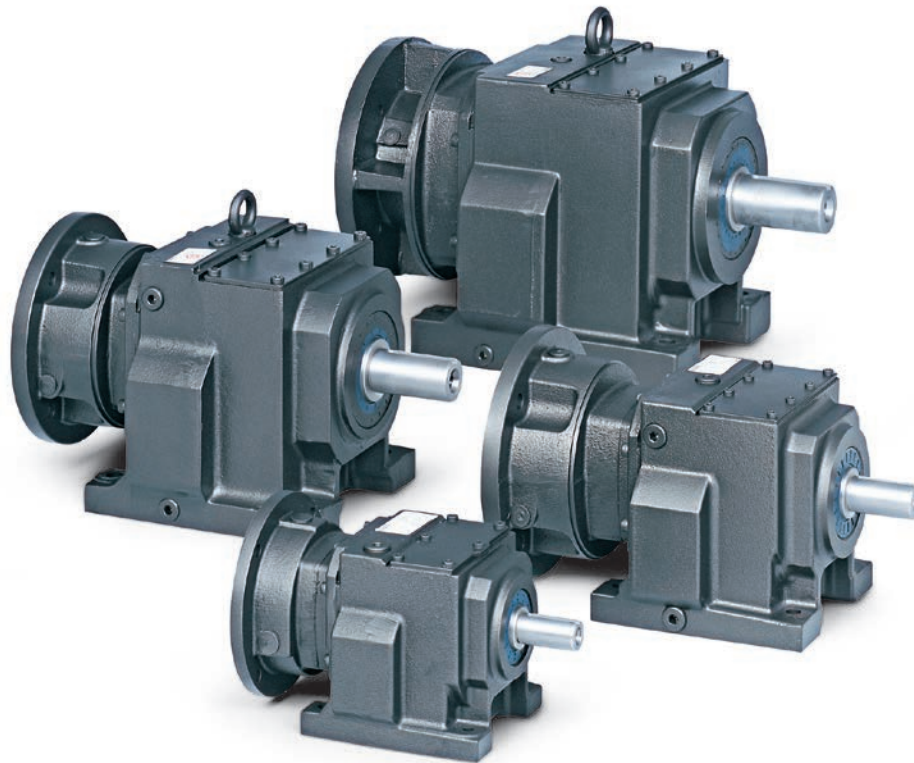

Baldor In-Line Helical C-Face Reducer Sizes 38-88

Features and Benefits

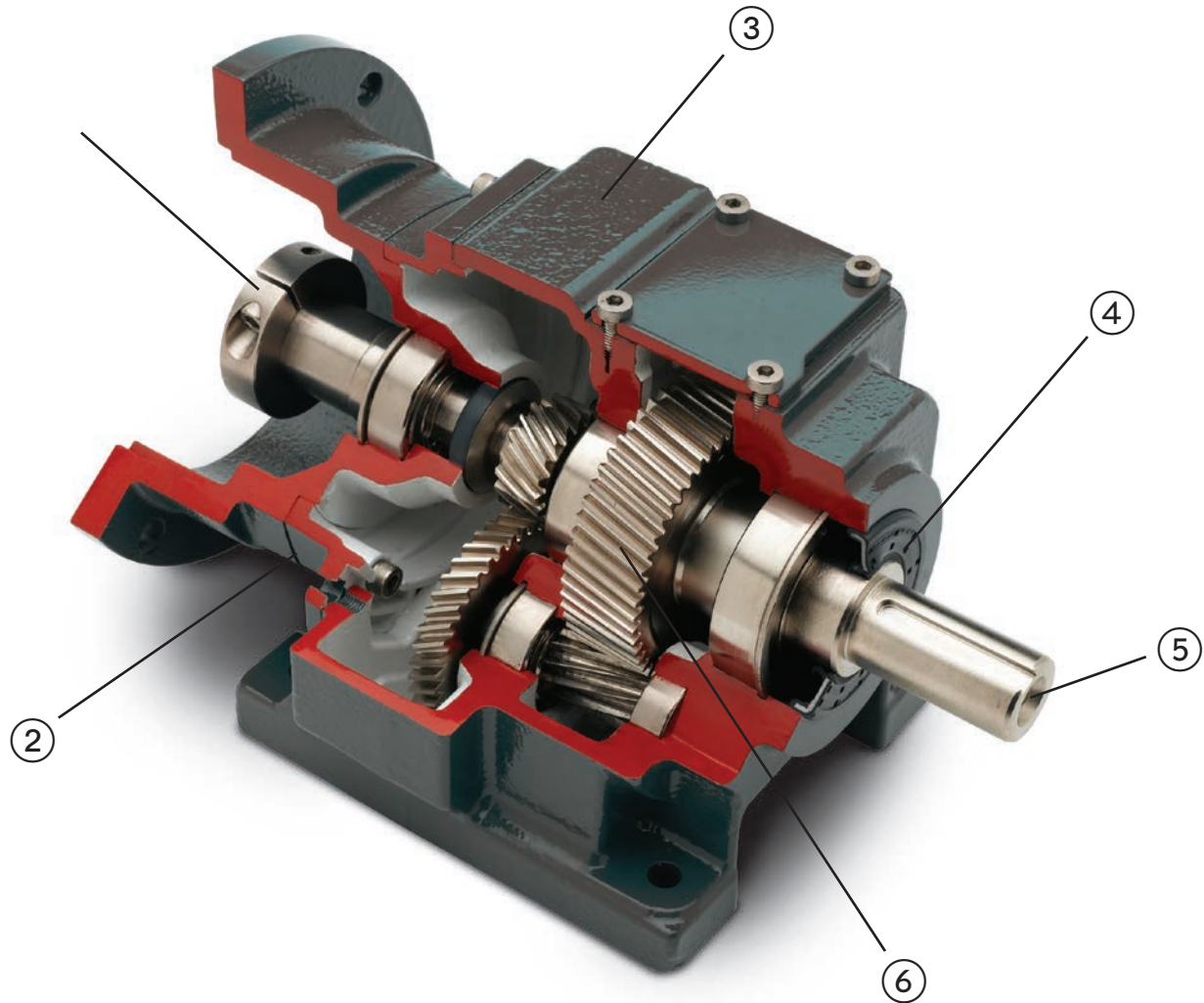

1. Multiple input options
 - C-Face adapters for mounting of NEMA and IEC motors
 - Separate Input
2. All gearboxes are factory filled with Mobilgear 600 XP 220
3. Reducer housings are constructed of class 30 gray iron with cast internal ribbing for added strength
4. Spring loaded double lip seals of nitrile rubber (NBR) material. All seals are rubber coated to eliminate seal-to-bore joint leakage.

5. High strength carbon steel shafts in inch and metric diameters
6. Gearing is of single helical design and ground to provide ellipsoid tooth which eliminates tooth wearing and assures meshing in the strongest tooth area
 - Gear material is alloy steel
 - Gears are case hardened and ground to AGMA class 11
 - 20 degree pressure angle to minimize noise
 - 98% efficient per stage of gearing

Baldor In-Line Helical C-Face Reducer Sizes 38-88 Selection

H50 Reducer

900 Series Single Reduction

900 Series Double Reduction

Accessories

Ratio Multipliers

In-Line Helical (ILH)

Universal Series Single Reduction

Universal Series Double Reduction

Engineering

Step 1: For applications with one start/hour or less and constant load skip Step 2 and proceed to Step 3. For application with more than one start/hour proceed to Step 2. For pulsating (cyclic) loads contact Application Engineering.

Step 2: Determine mass acceleration factor.

$$\text{Mass Acceleration Factor} = \frac{\text{all exterior moments of inertia}}{\text{moment of inertia of drive motor}} \quad [lb - ft^2]$$

Where:

Drive Motor Inertia must be provided by the motor manufacturer.

Exterior moments of inertia are defined as the “load inertia” referred to the motor speed. The “load inertia” must be provided by the driven machine manufacturer.

$$\text{Exterior Moment of Inertia (Rotating)} = \text{Load Inertia} \times \frac{\text{Load RPM}^2}{\text{Motor RPM}}$$

Where: W = Weight (lbs)
V = Linear Velocity (Ft./Min.)
N = Motor RPM

Note: Gearbox inertia, not addressed above, are typically negligible. If required, inertia values for the Baldor ILH units may be obtained from your local Baldor Sales Office.

Step 3: With inertia ratio determined, use Chart 1 to select load classification.

Chart 1 Load Classification

Load Classification	Driven Machine
I Light Shocks	Mass acceleration factor ≤ 3: Generators, belt conveyors, platform conveyors, auxiliary machine tool drives, turbo blowers, turbo compressors, agitator and mixers for light uniform density materials.
II Moderate Shocks	Mass acceleration factor ≤ 3: Main machine tool drives slewing gear, cranes, inducted draught fans, mixer and agitator for materials with variable density, multi cylinder piston pumps, metering pumps.
III Heavy Shocks	Mass acceleration factor ≤ 10: Punch presses, shears, Banbury mixers, rolling mill and foundry drives, bucket dredger, heavy centrifugal drives, heavy metering pumps, rotary drilling equipment, briquet presses, pug mills

Baldor In-Line Helical C-Face Reducer Sizes 38-88 Selection

Step 4: Service Factor

The listed service factors in Chart 2, apply only when integral electric motors are used as prime motors and are for general industrial applications. Please contact your Baldor Sales Office when any of the following conditions are expected:

- Instantaneous loads exceed 200% of the reducer ratings
- Frequent or cyclical speed changes
- Heavy shock loads
- Reversing loads
- Temperature variations
- Prime movers other than electric motors
- Other questionable conditions

Daily Operation		8 Hours			16 Hours			24 Hours		
Starts/Hour		< 10	10 - 200	> 200	< 10	10 - 200	> 200	< 10	10 - 200	> 200
Load Classification	I	1.0	1.1	1.2	1.1	1.2	1.3	1.3	1.4	1.5
	II	1.2	1.3	1.4	1.3	1.4	1.5	1.5	1.6	1.7
	III	1.4	1.5	1.6	1.5	1.6	1.7	1.7	1.8	2.0

Step 5: Reducer Selection

Using the service factor obtained in Step 4, calculate the equivalent HP by multiplying the motor HP to be transmitted by the service factor. The electric motor nameplate rating should be used for the demand HP.

$$\text{Equivalent } H_p = \text{Motor } H_p \times \text{Service Factor}$$

Step 6: Selection

Reducer Selection:

From rating tables in this catalog make reducer selection based on input RPM, ratio, and equivalent Hp.

Step 7: Check overhung loads by using the following formula

$$\text{OHL} = \frac{126,000 \times H_p \times K}{PD \times RPM}$$

- Where:
- OHL = Overhung load (lbs)
 - H_p = Demand Horsepower
 - K = Load Connection Factor
 - Chain Drive: F_c = 1.00
 - Spur or Helical Gear: F_c = 1.25
 - Synchronous Belt Drive: F_c = 1.30
 - V-Belt Drive: F_c = 1.50
 - Flat Belt: F_c = 2.50
 - PD = Pitch Diameter (inches)
 - RPM = Revolutions Per Minute (output)

The calculated OHL must be less than the allowable OHL.

To minimize overhung load and increase bearing life, the load center line should be located as close to the shaft shoulder as possible. For applications where OHL exceeds catalogued values use the reducer selection tables to select the next largest size gear case or contact your Baldor Sales Office.

Baldor In-Line Helical C-Face Reducer Sizes 38-88

How to Order

H50
Reducer

900 Series
Single Reduction

900 Series
Double Reduction

Accessories

Ratio Multipliers

In-Line Helical (LH)

Universal Series
Single Reduction

Universal Series
Double Reduction

Engineering

Service Factor Classification For Industry Applications

Applications which expose the gear drive to high starting torques, extreme repetitive shock, or where high energy loads must be absorbed as when stalling, require special consideration. Service factors for the special applications should be agreed upon by the user and Baldor since variations of the values in the chart may be required.

The service factors in the service factor table are based on the use of an electric or hydraulic motor or the use of a steam or gas turbine as a prime mover. If the prime mover is a single or multi-cylinder engine, then the service factor must be adjusted in accordance with the chart below.

CONVERSION FACTORS FOR INTERNAL COMBUSTION ENGINE DRIVERS		
Electric Motor Drive	Multi-Cylinder Internal Combustion Engine	Single-Cylinder Internal Combustion Engine
1.00	1.25	1.50
1.25	1.50	1.75
1.50	1.75	2.00
1.75	2.00	2.25
2.00	2.25	2.50

Baldor In-Line Helical C-Face Reducer Sizes 38-88

How to Order

Service Factor

Application	Recommended Service Factors		
	Up to 3 Hrs/Day	3 - 10 Hrs/Day	Over 10 Hrs/Day
AGITATORS (Mixers)			
Pure Liquids	—	1.00	1.25
Liquids & Solids	1.00	1.25	1.50
Liquids - Variable Density	1.00	1.25	1.50
BLOWERS			
Centrifugal	1.00	1.25	—
Lobe	1.00	1.25	1.50
Vane	—	1.00	1.25
BREWING & DISTILLING			
Bottling Machinery	—	1.00	1.25
Brew Kettles (Continuous Duty)	—	1.00	1.25
Cookers (Continuous Duty)	—	1.00	1.25
Mash Tubs (Continuous Duty)	—	1.00	1.25
Scale Hopper (Frequent Starts)	1.00	1.25	1.50
CAN FILLING MACHINES	—	1.00	1.25
CAR DUMPERS	1.25	1.50	1.75
CAR PULLERS	1.00	1.25	1.50
CLARIFIERS	—	1.00	1.25
CLASSIFIERS	1.00	1.25	1.50
CLAY WORKING MACHINERY			
Brick Press	1.25	1.50	1.75
Briquette Machine	1.25	1.50	1.75
Pug Mill	1.00	1.25	1.50
COMPACTORS	1.50	1.75	2.00
COMPRESSORS			
Centrifugal	—	1.00	1.25
Lobe	1.00	1.25	1.50
Reciprocating, Multi - Cylinder	1.00	1.25	1.50
Reciprocating, Single - Cylinder	1.25	1.50	1.75
CONVEYORS - GENERAL PURPOSE			
Uniformly loaded or fed	—	1.00	1.25
Not uniformly fed	1.00	1.25	1.50
Reciprocating or Shaker	1.25	1.50	1.75
CRANES			
Dry Dock			
Main Hoist	1.25	1.50	1.75
Auxiliary Hoist	1.25	1.50	1.75
Boom Hoist	1.25	1.50	1.75
Slewing Drive	1.25	1.50	1.75
Traction Drive	1.50	1.50	1.50
Container			
Main Hoist	*	*	*
Boom Hoist	*	*	*
Trolley Travel	*	*	*
Gantry Drive	*	*	*
Traction Drive	*	*	*
Mill Duty			
Main Hoist	*	*	*
Auxiliary	*	*	*
Bridge and Trolley Travel	*	*	*
Industrial Duty			
Main	1.00	1.25	1.50
Auxiliary	*	*	*
Bridge and Trolley Travel	*	*	*
CRUSHER			
Stone or Ore	1.50	1.75	2.00
DREDGES			
Cable Reels	1.00	1.25	1.50
Conveyors	1.00	1.25	1.50
Cutter Head Drives	1.25	1.50	1.75
Pumps	1.00	1.25	1.50
Screen Drives	1.25	1.50	1.75
Stackers	1.00	1.25	1.50
Winches	1.00	1.25	1.50
ELEVATORS			
Bucket	1.00	1.25	1.50
Centrifugal Discharge	—	1.00	1.25
Escalators	*	*	*
Freight	*	*	*
Gravity Discharge	—	1.00	1.25
EXTRUDERS			
General	1.25	1.25	1.25
Plastics			
(a) Variable Speed Drive	1.50	1.50	1.50
(b) Fixed Speed Drive	1.75	1.75	1.75
Rubber			
(a) Continuous Screw Operation	1.50	1.50	1.50
(b) Intermittent Screw Operation	1.75	1.75	1.75

Application	Recommended Service Factors		
	Up to 3 Hrs/Day	3 - 10 Hrs/Day	Over 10 Hrs/Day
FANS			
Centrifugal	—	1.00	1.25
Cooling Towers		*	*
Forced Draft	1.25	1.25	1.25
Induced Draft	1.00	1.25	1.50
Industrial & Mine	1.00	1.25	1.50
FEEDERS			
Apron	—	1.25	1.50
Belt	1.00	1.25	1.50
Disc	—	1.00	1.25
Reciprocating	1.25	1.50	1.75
Screw	1.00	1.25	1.50
FOOD INDUSTRY			
Cereal Cooker	—	1.00	1.25
Dough Maker	1.00	1.25	1.50
Meat Grinder	1.00	1.25	1.50
Slicers	1.00	1.25	1.50
GENERATORS & EXCITERS	—	1.00	1.25
HAMMER MILLS	1.50	1.50	1.75
HOISTS			
Heavy Duty	1.25	1.50	1.75
Medium Duty	1.00	1.25	1.50
Skip Hoist	1.00	1.25	1.50
LAUNDRY TUMBLERS	1.00	1.25	1.50
LAUNDRY WASHERS	1.25	1.25	1.50
LUMBER INDUSTRY			
Barkers - Spindle Feed	1.25	1.25	1.50
- Main Drive	1.50	1.50	1.50
Conveyors - Burner	1.25	1.25	1.50
- Main or Heavy Duty	1.50	1.50	1.50
- Main Log	1.50	1.50	1.75
- Re-Saw, Merry-Go-Round	1.25	1.25	1.50
- Slab	1.50	1.50	1.75
- Transfer	1.25	1.25	1.50
Chains - Floor	1.50	1.50	1.50
- Green	1.50	1.50	1.50
Cut-Off Saws - Chain	1.50	1.50	1.50
- Drag	1.50	1.50	1.50
Debarking Drums	1.50	1.50	1.75
Feeds - Edger	1.25	1.25	1.50
- Gang	1.50	1.50	1.50
- Trimmer	1.25	1.25	1.50
Log Deck	1.50	1.50	1.50
Log Hauls - Incline - Well Type	1.50	1.50	1.50
Log Turning Devices	1.50	1.50	1.50
Planer Feed	1.25	1.25	1.50
Planer Tilting Hoist	1.50	1.50	1.50
Rolls - Live, Off Brg., Roll Cases	1.50	1.50	1.50
Sorting Table	1.25	1.25	1.50
Tipple Hoist	1.25	1.25	1.50
Transfers - Chain	1.50	1.50	1.50
- Craneway	1.50	1.50	1.50
Tray Drives	1.25	1.25	1.50
Veneer Lathe Drives	*	*	*
METAL MILLS			
Draw Bench Carriage & Main Drive	1.00	1.25	1.50
Run Out Tables			
Non-Reversing			
Group Drives	1.00	1.25	1.50
Individual Drives	1.50	1.50	1.75
Reversing	1.50	1.50	1.75
Slab Pushers	1.25	1.25	1.50
Shears	1.50	1.50	1.75
Wire Drawing	1.00	1.25	1.50
Wire Winding Machine	1.00	1.25	1.50
METAL MILLS			
Draw Bench Carriage & Main Drive	1.00	1.25	1.50
Run Out Tables			
Non-Reversing			
Group Drives	1.00	1.25	1.50
Individual Drives	1.50	1.50	1.75
Reversing	1.50	1.50	1.75
Slab Pushers	1.25	1.25	1.50
Shears	1.50	1.50	1.75
Wire Drawing	1.00	1.25	1.50
Wire Winding Machine	1.00	1.25	1.50

* Refer to company

H50 Reducer

900 Series Single Reduction

900 Series Double Reduction

Accessories

Ratio Multiplier

In-Line Helical (LH)

Universal Series Single Reduction

Universal Series Double Reduction

Engineering

Baldor In-Line Helical C-Face Reducer Sizes 38-88

How to Order

Service Factor (continued)

Application	Recommended Service Factors		
	Up to 3 Hrs/Day	3 - 10 Hrs/Day	Over 10 Hrs/Day
METAL STRIP PROCESSING			
MACHINERY			
Bridles	1.25	1.25	1.50
Coilers & Uncoilers	1.00	1.00	1.25
Edge Trimmers	1.00	1.25	1.50
Flatteners	1.00	1.25	1.50
Loopers (Accumulators)	1.00	1.00	1.00
Pinch Rolls	1.00	1.25	1.50
Scrap Choppers	1.00	1.25	1.50
Shears	1.50	1.50	1.75
Slitters	1.00	1.25	1.50
MILLS, ROTARY TYPE			
Bell & Rod			
Spur Ring Gear	1.50	1.50	1.75
Helical Ring Gear	1.50	1.50	1.50
Direct Connected	1.50	1.50	1.75
Cement Kilns	1.50	1.50	1.50
Dryers & Coolers	1.50	1.50	1.50
	1.00	1.25	1.50
MIXERS, CONCRETE			
PAPER MILLS			
Agitator (Mixer)	1.50	1.50	1.50
Agitator for Pure Liquids	1.25	1.25	1.25
Barker Drums	1.75	1.75	1.75
Barker - Mechanical	1.75	1.75	1.75
Beater	1.50	1.50	1.50
Breaker Stack	1.25	1.25	1.25
Calender (Anti-Friction Bearings Only)	1.25	1.25	1.25
Chipper	1.75	1.75	1.75
Chip Feeder	1.50	1.50	1.50
Coating Rolls	1.25	1.25	1.25
Conveyors			
Chip, Bark, Chemical Log (Including Slab)	1.25	1.25	1.25
	1.75	1.75	1.75
Couch Rolls	1.25	1.25	1.25
Cutter	1.75	1.75	1.75
Cylinder Molds	1.25	1.25	1.25
Dryers (Anti-Friction Bearings Only)			
Paper Machine Conveyor Type	1.25	1.25	1.25
Embosser	1.25	1.25	1.25
Extruder	1.50	1.50	1.50
Fourdrinier Rolls (Includes Lump Breaker, Dandy Roll, Wire Turning & Return Rolls)	1.25	1.25	1.25
Jordan	1.25	1.25	1.25
Kiln Drive	1.50	1.50	1.50
Mt. Hope Rolls	1.25	1.25	1.25
Paper Rolls	1.25	1.25	1.25
Platter	1.50	1.50	1.50
Pressers - Felt & Suction	1.25	1.25	1.25
Pulper	1.50	1.50	1.75
Pumps - Vacuum	1.50	1.50	1.50
Reel (Surface Type)	1.25	1.25	1.50
Screens			
Chip	1.50	1.50	1.50
Rotary	1.50	1.50	1.50
Vibrating	1.75	1.75	1.75
Size Press	1.25	1.25	1.25
Super Calender	1.25	1.25	1.25
Thickener (AC Motor)	1.50	1.50	1.50
(DC Motor)	1.25	1.25	1.25
Washer (AC Motor)	1.50	1.50	1.50
(DC Motor)	1.25	1.25	1.25
Wind & Unwind Stand	1.00	1.00	1.00
Winders (Surface Type)	1.25	1.25	1.25
Yankee Dryers (Anti-Friction Bearings Only)	1.25	1.25	1.25
PLASTICS INDUSTRY – PRIMARY PROCESSING			
Intensive Internal Mixers	1.75	1.75	1.75
(a) Batch Mixers	1.50	1.50	1.50
(b) Continuous Mixers	1.50	1.50	1.50
Batch Drop Mill - 2 Smooth Rolls	1.25	1.25	1.25
Continuous Feed, Holding & Blend Mill	1.25	1.25	1.25
Compounding Mills	1.25	1.25	1.25
Calenders	1.50	1.50	1.50

Application	Recommended Service Factors		
	Up to 3 Hrs/Day	3 - 10 Hrs/Day	Over 10 Hrs/Day
PLASTICS INDUSTRY – SECONDARY PROCESSING			
Blow Molders	1.50	1.50	1.50
Coating	1.25	1.25	1.25
Film	1.25	1.25	1.25
Pipe	1.25	1.25	1.25
Pre-Plasticizers	1.50	1.50	1.50
Rods	1.25	1.25	1.25
Sheet	1.25	1.25	1.25
Tubing	1.25	1.25	1.50
PULLERS - BARGE HAUL PUMPS			
Centrifugal	—	1.00	1.25
Proportioning	1.00	1.25	1.50
Reciprocating			
Single Acting, 3 or more cylinders	1.00	1.25	1.50
Double Acting, 2 or more cylinders	1.00	1.25	1.50
Rotary - Gear Type	—	1.00	1.50
- Lobe	—	1.00	1.25
- Vane	—	1.00	1.25
RUBBER INDUSTRY			
Intensive Internal Mixers			
(a) Batch Mixers	1.50	1.75	1.75
(b) Continuous Mixers	1.25	1.50	1.50
Mixing Mill			
2 Smooth Rolls (if corrugated rolls are used, than the same service factors that are used for a Cracker Warmer)	1.50	1.50	1.50
Batch Drop Mill - 2 Smooth Rolls	1.50	1.50	1.50
Cracker Warmer - 2 Rolls; 1 corrugated roll	1.75	1.75	1.75
Cracker - 2 corrugated rolls	1.75	1.75	1.75
Holding, Feed & Blend Mill - 2 Rolls	1.25	1.25	1.25
Refiner - 2 Rolls	1.50	1.50	1.50
Calenders	1.50	1.50	1.50
	1.00	1.25	1.50
SAND MILLER			
SEWAGE DISPOSAL EQUIPMENT			
Bar Screens	—	1.00	1.25
Chemical Feeders	—	1.00	1.25
Dewatering Screens	1.00	1.25	1.50
Scum Breakers	1.00	1.25	1.50
Slow or Rapid Mixers	1.00	1.25	1.50
Sludge Collectors	1.00	1.00	1.25
Thickeners	1.00	1.25	1.50
Vacuum Filters	1.00	1.25	1.50
SCREENS			
Air Washing	—	1.00	1.25
Rotary - Stone or Gravel	1.00	1.25	1.50
Traveling Water Intake	—	1.00	1.25
SUGAR INDUSTRY			
Beet Slicer	1.50	1.50	1.75
Cane Knives	1.50	1.50	1.50
Crushers	1.50	1.50	1.50
Mills (Low Speed End)	1.50	1.50	1.50
TEXTILE INDUSTRY			
Batchers	1.00	1.25	1.50
Calenders	1.00	1.25	1.50
Cards	1.00	1.25	1.50
Dry Cans	1.00	1.25	1.50
Dryers	1.00	1.25	1.50
Dyeing Machinery	1.00	1.25	1.50
Looms	1.00	1.25	1.50
Mangles	1.00	1.25	1.50
Nappers	1.00	1.25	1.50
Pads	1.00	1.25	1.50
Slashers	1.00	1.25	1.50
Soapers	1.00	1.25	1.50
Spinners	1.00	1.25	1.50
Tenter Frames	1.00	1.25	1.50
Washers	1.00	1.25	1.50
Winders	1.00	1.25	1.50

* Refer to company

Baldor In-Line Helical C-Face Reducer Sizes 38-88 Nomenclature

In-Line Helical C-Face Reducers (ILH)

Ex:

1	2	3	4	5	6	7	/	8	9	10	10a	10b	11	11a
H	B	88	2	C	N	180TC	/	20.81	A1	S	I	2.125	—	—

1. PRODUCT TYPE

H = ILH

2. OUTPUT CONFIGURATION

B = Foot Mounted

F = Flange Mounted

3. UNIT SIZE

38 48 68 88

4. STAGE OF REDUCTION

1 = Single Reduction

2 = Double Reduction

3 = Triple Reduction

5. INPUT CONFIGURATION

C = Clamp Collar

L = 3 Pc Coupling

6. MOTOR TYPE

N = Nema

I = IEC

7. MOTOR FRAME

NEMA

56C 140TC 180TC 210TC 250TC

IEC

71D 80D 90D 100D 112D 132D 160D

8. RATIO (Use actual ratio from Selection pages)

ILH 38 1.59 - 191.75

ILH 48 1.52 - 208.77

ILH 68 1.41 - 281.01

ILH 88 1.71 - 300.41

9. MOUNTING POSITIONS (See page 106)

A1 A2 A3

A4 A5 A6

10. OUTPUT SHAFT TYPE

S = Single Extension Solid Shaft

10a. OUTPUT SHAFT DIMENSION

I = Inch

M = Metric

10b. OUTPUT SHAFT DIAMETER - Double/Triple Reduction

	Std		Optional	
ILH 38	1.000	1.250	25mm	30mm
ILH 48	1.250	1.625	30mm	40mm
ILH 68	1.625	2.125	40mm	50mm
ILH 88	2.125	2.375	50mm	60mm

10b. OUTPUT SHAFT DIAMETER - Single Reduction

	Std	Optional
ILH 38	0.875	20mm
ILH 48	1.125	25mm
ILH 68	1.375	30mm
ILH 88	1.625	40mm

11. OUTPUT FLANGE TYPE (HF Style Housing)

B5
B14 (Std)
NEMA (Single Reduction)

11a. OUTPUT FLANGE DIAMETER - Double/Triple Reduction

	Std B14 Flange	Optional	
		B5 Flange	B5 Flange
ILH 38	120mm	160mm	200mm
ILH 48	160mm	200mm	250mm
ILH 68	190mm	250mm	300mm
ILH 88	245mm	300mm	

OUTPUT FLANGE DIAMETER - Single Reduction

	Std B14 Flange	Optional	
		B5 Flange	NEMA Flange
ILH 38	120mm	160mm	140TC
ILH 48	120mm	160mm	180TC
ILH 68	160mm	200mm	210TC
ILH 88	190mm	250mm	—

H50 Reducer

900 Series Single Reduction

900 Series Double Reduction

Accessories

Ratio Multiplier

In-Line Helical (ILH)

Universal Series Single Reduction

Universal Series Double Reduction

Engineering

Baldor In-Line Helical C-Face Reducer Sizes 38-88 Nomenclature

In-Line Helical Separate Reducers (ILH)

Ex:

1	2	3	4	5	6	7	/	8	9	10	10a	10b	11	11a
H	F	38	2	S	I	71	/	4.77	A1	S	I	1.000	B5	160MM

1. PRODUCT TYPE

H = ILH

2. OUTPUT CONFIGURATION

B = Foot Mounted

F = Flange Mounted

3. UNIT SIZE

38 48 68 88

4. STAGE OF REDUCTION

1 = Single Reduction

2 = Double Reduction

3 = Triple Reduction

5. INPUT CONFIGURATION

S = Separate

6. INPUT SHAFT DIMENSION

I = Inch

M = Metric

7. SEPARATE GROUP

71 80 90 100 112 132 160

8. RATIO (Use actual ratio from Selection pages)

ILH 38	1.59	-	191.75
ILH 48	1.52	-	208.77
ILH 68	1.41	-	281.01
ILH 88	1.71	-	300.41

9. MOUNTING POSITIONS (See page 106)

A1	A2	A3
A4	A5	A6

10. OUTPUT SHAFT TYPE

S = Single Extension Solid Shaft

10a. OUTPUT SHAFT DIMENSION

I = Inch

M = Metric

10b. OUTPUT SHAFT DIAMETER - Double/Triple Reduction

	Std	Optional		
ILH 38	1.000	1.250	25mm	30mm
ILH 48	1.250	1.625	30mm	40mm
ILH 68	1.625	2.125	40mm	50mm
ILH 88	2.125	2.375	50mm	60mm

OUTPUT SHAFT DIAMETER - Single Reduction

	Std	Optional
ILH 38	0.875	20mm
ILH 48	1.125	25mm
ILH 68	1.375	30mm
ILH 88	1.625	40mm

11. OUTPUT FLANGE TYPE (HF Style Housing)

B5

B14 (Std)

NEMA (Single Reduction)

11a. OUTPUT FLANGE DIAMETER - Double/Triple Reduction

	Std B14 Flange	Optional B5 Flange
ILH 38	120mm	160mm 200mm
ILH 48	160mm	200mm 250mm
ILH 68	190mm	250mm 300mm
ILH 88	245mm	300mm 350mm

OUTPUT FLANGE DIAMETER - Single Reduction

	Std B14 Flange	Optional B5 Flange	NEMA Flange
ILH 38	120mm	160mm 200mm	140TC
ILH 48	120mm	160mm 200mm	180TC
ILH 68	160mm	200mm 250mm	210TC
ILH 88	190mm	250mm 300mm	—

H50 Reducer

900 Series Single Reduction

900 Series Double Reduction

Accessories

Ratio Multipliers

In-Line Helical (ILH)

Universal Series Single Reduction

Universal Series Double Reduction

Engineering

Baldor In-Line Helical C-Face Reducer Sizes 38-88 Mounting Positions

Type	Reduction Stage	Mounting Position					
		A1	A2	A3	A4	A5	A6
		Pints	Pints	Pints	Pints	Pints	Pints
H_38	2	1.1	2.5	1.3	1.5	1.3	1.3
	3	1.1	2.3	1.3	1.9	1.3	1.3
H_48	2	2.3	5.1	3.2	3.8	3.4	2.7
	3	2.3	5.1	3.2	4.9	3.2	3.0
H_68	2	3.8	8.7	5.3	6.8	5.7	4.9
	3	3.6	8.5	5.5	8.5	5.5	5.1
H_88	2	8.7	18.6	12.0	15.9	12.9	11.2
	3	8.5	18.8	12.5	19.7	12.5	11.4

Do not mix oils from different manufacturers. If a change to another type or brand of oil is made, the existing lubricant should be drained and the gear case flushed with a small quantity of the new lubricant before refilling with the new lubricant. This is necessary to avoid possible incompatibility problems between the two lubricants. The list below gives approved alternative lubricants. This is not an exclusive list. Equivalent lubricants from other manufacturers may be used.

Lubricant Selection Table

Ambient Temperature*	Oil Type	ISO Viscosity Grade	Examples of Lubricants
			Mobil
10° F to 104° F (-12° C to 40° C)	Mineral Oil	220	Mobilgear 600 XP 220
0° F to 70° F (-18° C to 21° C)	Mineral Oil	100	Mobilgear 600 XP 100
-35° F to 125° F (-37° C to 53° C)	Synthetic Oil	220	Mobil SHC 630**

Other brand recommendations are available upon request. Contact your Baldor Sales Office.

* Ambient temperatures listed are for lubricant only and do not indicate a particular gear unit's suitability to run in that ambient.

Recommendations will be made based on specific application details.

** Requires Viton Seals

LONG TERM STORAGE

If the drive is not installed immediately, it should be stored in a clean, dry, protected area. During periods of long term storage (six months or longer) special procedures must be followed. The unit should be filled to the highest oil level hole with an approved lubricant blended with 2%, by volume, of "Daubert Chemical Co. Nox-Rust VCI-105" oil. Apply a thick coating of rust preventative on all unpainted surfaces including threads, bores, keyways, and shafts. Apply a thick coating of chassis-type grease to all exposed shaft seals. If the unit is to be stored outdoors or in a damp, unheated area indoors, cover the entire exterior with a rust preventative. Seal the unit in a moisture proof container or wrapping with a desiccant inside. Shade the enclosure from direct sunlight. Rotate the input shaft at least 60 revolutions once a month to redistribute the lubricant and prevent brinelling of bearings and drying of seals.

Upon removal from storage, remove all protective coatings applied for protection during storage. Check all hardware for proper tightness. Drain and refill the gear reducer with a recommended lubricant. If the gear reducer has been stored for more than three years or in an area with high ambient temperatures, replace the oil seals.

Baldor In-Line Helical C-Face Reducer Sizes 38-88 Mounting Positions

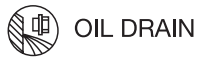

OIL DRAIN



VENTILATION



OIL LEVEL

A1 Horizontal - Floor Mount

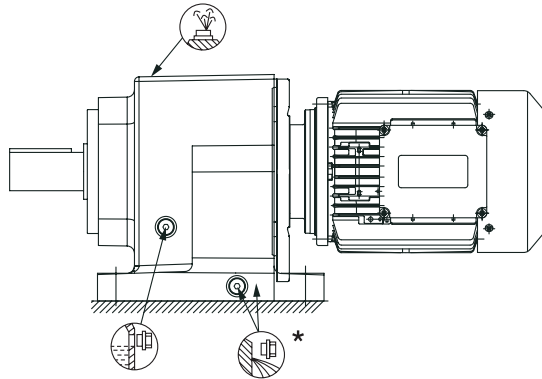

A2 Vertical Wall Mount - Motor Shaft Up

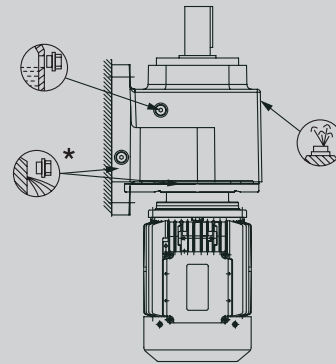

A3 Horizontal - Ceiling Mount

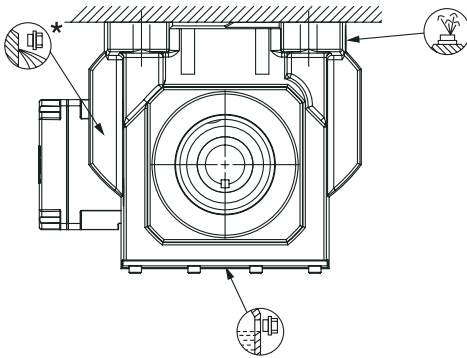

A4 Vertical Wall Mount - Motor Shaft Down

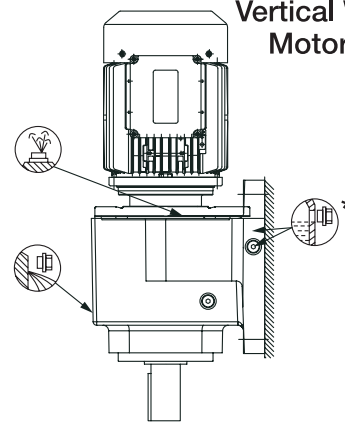

A5 Horizontal - Wall Mount

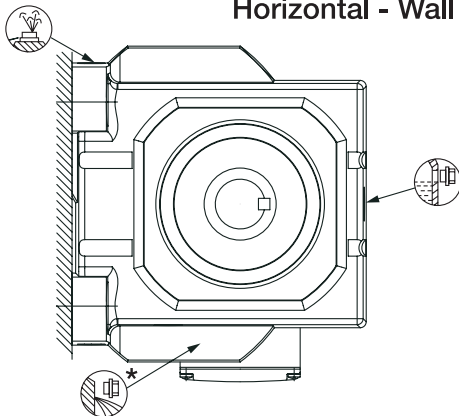

A6 Horizontal - Wall Mount

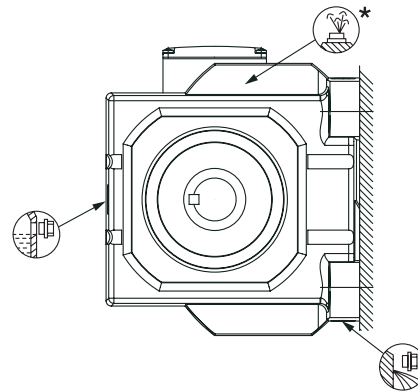

Note: * On opposite side

HB38 and HF38 units are sealed and furnished with only one plug for the purpose of filling and draining.

Shaded mounting position not recommended. For maximum seal life, the reducer should be mounted with the high speed (input) shaft as high as possible.

Baldor In-Line Helical C-Face Reducer Sizes 38-88 Lubrication Options

The list below shows lubricants that are available as factory fill in Baldor ILH reducers. The standard factory fill lubricant is Mobilgear 600, XP 220, which is a high performance mineral oil lubricant with special additives for use in industrial gear products.

Ambient Temperature	Oil Type	ISO Viscosity Grade	Available Oils	Available Food Grade Oils (NSF H1)
10° F to 105° F (-12° C to 41° C)	Mineral Oil	220	Mobilgear 600 XP 220 (standard fill)	—
-20° F to 50° F (-29° C to 13° C)	Synthetic	68	Mobil SHC 626	—
-10° F to 115° F (-23° C to 46° C)	Synthetic	220	Mobil SHC 630	—
30° F to 140° F (-0° C to 60° C)	Synthetic	460	Mobil SHC 634	—
25° F to 75° F (-4° C to 29° C)	Mineral Oil	220	—	Chevron FM 220
45° F to 105° F (7° C to 41° C)	Mineral Oil	460	—	Chevron FM 460

Ambient temperatures listed are for lubricants only and do not indicate a particular gear unit's suitability to run in that ambient.

All reducers are factory filled according to the mounting position indicated on the order. If the mounting position is changed from the ordered mounting position, the oil level must be changed. The oil volumes shown in the mounting position charts are approximate. The correct oil level is determined by the oil level hole in the housing except for size 38 reducers. If the reducer is ordered with the standard mineral oil and the oil is later changed to synthetic oil, it is recommended the shaft seals be changed to Viton (FKM) material.

ILH reducers are furnished with oil level, drain, and fill plugs except for the size 38, which only has a fill plug. Before starting operation, the breather must be located in the correct location.

Continued operation in cold ambient conditions requires special modifications. Please contact your local Baldor Sales Office.

The density of the standard factory fill oil is 0.93 lbs/pint (1.98 lbs/liter).

Baldor In-Line Helical C-Face Reducer Sizes 38-88 Incline Mountings

H50 Reducer

900 Series Single Reduction

900 Series Double Reduction

Accessories

Ratio Multipliers

In-Line Helical (ILH)

Universal Series Single Reduction

Universal Series Double Reduction

Engineering

Baldor ILH Incline Mountings

Baldor reducers can be modified to permit mounting in positions other than the standard mounting positions shown in the mounting position charts including inclined and tilted positions. Consult application engineering to determine what modifications are required for your specific application.

In order for Baldor to make recommendations on the required modifications, the following information must be provided:

- Reducer Size
- Ratio
- Input and/or Output speed
- Transmitted Horsepower
- Duty Cycle — Continuous vs. intermittent operation. If intermittent, running time vs. idle time.
- Mounting position, such as A1, A2. . . A6 with shafts level, a complete description of the mounting arrangement including the angle of tilt of the housing, the incline of the shafts and whether the output shaft is higher or lower than the input shaft.

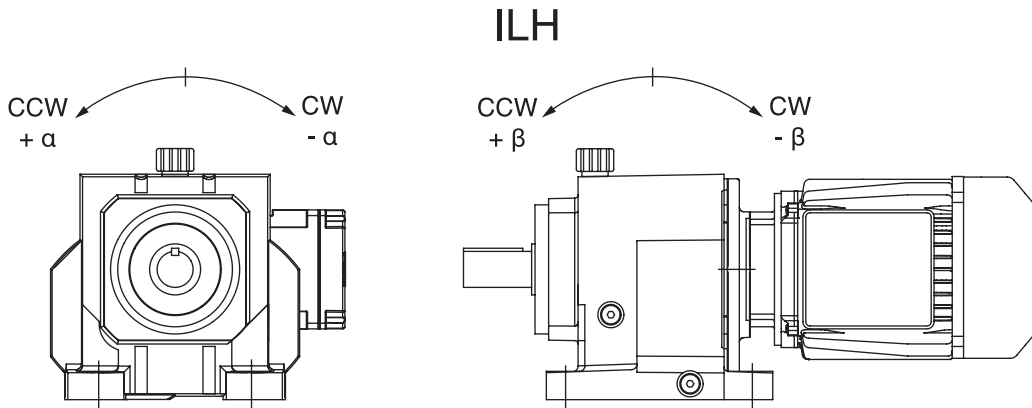

For the example shown here – the unit would be called out with a CW rotation from a A1 mounting position of 30 degrees (Angle °). This illustration represents a typical arrangement for a tilted reducer. The proper oil level will vary with reducer size, ratio, input speed and angle of tilt. Contact your local Baldor Sales Office.

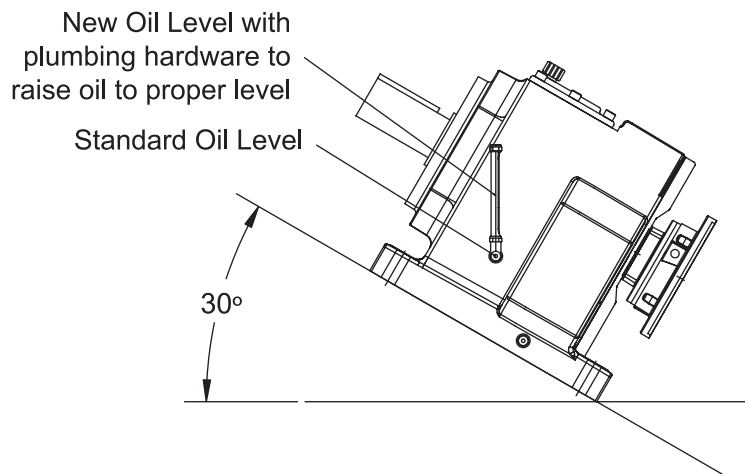

In-Line Helical Reducer (ILH)

Size: 381

Service Factor 1.0 – Clamp Collar / 3 Pc Coupled / Separate SINGLE REDUCTION

NEMA Motor Frame IEC Motor Frame Separate Group		56C 71D 71	— 80D 80	140TC 90D 90	180TC 100D 100
Ratio	Output Rating Data	1750	1750	1750	1750
1.59	Output RPM	1100	1100	1100	1100
	Input HP (Max)	2.02	2.46	4.84	8.87
	Output Torque, In-Lb	116	141	277	508
	OHL Input Shaft	55	55	140	190
	OHL Output Shaft (B)	—	—	—	—
1.85	Output RPM	946	946	946	946
	Input HP (Max)	2.02	2.46	4.60	8.37
	Output Torque, In-Lb	134	164	306	557
	OHL Input Shaft	55	55	140	190
	OHL Output Shaft (B)	—	—	—	—
2.05	Output RPM	853	853	853	853
	Input HP (Max)	2.02	2.46	4.42	8.01
	Output Torque, In-Lb	149	182	327	592
	OHL Input Shaft	55	55	140	190
	OHL Output Shaft (B)	—	—	—	—
2.24	Output RPM	783	783	783	783
	Input HP (Max)	2.02	2.46	4.27	7.73
	Output Torque, In-Lb	163	198	343	622
	OHL Input Shaft	55	55	140	190
	OHL Output Shaft (B)	50	50	50	50
2.50	Output RPM	700	700	700	700
	Input HP (Max)	2.02	2.46	4.06	7.18
	Output Torque, In-Lb	182	221	366	646
	OHL Input Shaft	55	55	140	190
	OHL Output Shaft (B)	102	102	102	102
2.73	Output RPM	640	640	640	640
	Input HP (Max)	1.99	2.46	3.90	7.06
	Output Torque, In-Lb	196	242	384	695
	OHL Input Shaft	55	55	140	190
	OHL Output Shaft (B)	102	102	102	102
3.00	Output RPM	583	583	583	583
	Input HP (Max)	1.91	2.46	3.73	6.55
	Output Torque, In-Lb	206	266	403	708
	OHL Input Shaft	55	55	140	190
	OHL Output Shaft (B)	211	211	211	211
3.31	Output RPM	529	529	529	529
	Input HP (Max)	1.82	2.46	3.55	4.83
	Output Torque, In-Lb	217	293	423	575
	OHL Input Shaft	55	55	140	190
	OHL Output Shaft (B)	269	269	269	269
3.67	Output RPM	477	477	477	477
	Input HP (Max)	1.73	2.34	3.37	4.69
	Output Torque, In-Lb	228	309	445	620
	OHL Input Shaft	55	55	140	190
	OHL Output Shaft (B)	258	258	258	258

(A) Contact Engineering

(B) OHL is for standard solid shaft diameters. Reference page 146 for optional shaft diameters. OHL's are applied at one shaft diameter from the shaft shoulder. OHL is calculated for the maximum reducer rating. Larger OHL's may be applied under certain conditions and are subject to application engineering review.

Blank areas (—) indicate configuration not available

In-Line Helical Reducer (ILH)

Size: 381

Service Factor 1.0 – Clamp Collar / 3 Pc Coupled / Separate SINGLE REDUCTION

NEMA Motor Frame IEC Motor Frame Separate Group		56C 71D 71	— 80D 80	140TC 90D 90	180TC 100D 100
Ratio	Output Rating Data	1750	1750	1750	1750
4.15	Output RPM	421	421	421	421
	Input HP (Max)	1.61	2.18	3.16	3.67
	Output Torque, In-Lb	241	326	473	549
	OHL Input Shaft	55	55	140	190
	OHL Output Shaft (B)	371	371	371	371
4.58	Output RPM	382	382	382	382
	Input HP (Max)	1.52	2.06	3.01	4.18
	Output Torque, In-Lb	252	340	497	690
	OHL Input Shaft	55	55	140	190
	OHL Output Shaft (B)	371	371	371	371
5.18	Output RPM	338	338	338	338
	Input HP (Max)	1.41	1.92	2.81	3.32
	Output Torque, In-Lb	262	359	523	620
	OHL Input Shaft	55	55	140	190
	OHL Output Shaft (B)	543	543	543	543
5.92	Output RPM	296	296	296	—
	Input HP (Max)	1.26	1.77	2.20	—
	Output Torque, In-Lb	269	377	469	—
	OHL Input Shaft	55	55	140	—
	OHL Output Shaft (B)	543	543	543	—
6.73	Output RPM	260	260	260	—
	Input HP (Max)	1.13	1.62	1.75	—
	Output Torque, In-Lb	275	394	425	—
	OHL Input Shaft	55	55	140	—
	OHL Output Shaft (B)	583	583	583	—
7.20	Output RPM	243	243	243	—
	Input HP (Max)	1.07	1.30	1.30	—
	Output Torque, In-Lb	278	336	336	—
	OHL Input Shaft	55	55	140	—
	OHL Output Shaft (B)	583	583	583	—
8.30	Output RPM	211	211	—	—
	Input HP (Max)	0.95	0.95	—	—
	Output Torque, In-Lb	283	283	—	—
	OHL Input Shaft	55	55	—	—
	OHL Output Shaft (B)	834	834	—	—
9.33	Output RPM	188	—	—	—
	Input HP (Max)	0.84	—	—	—
	Output Torque, In-Lb	283	—	—	—
	OHL Input Shaft	55	—	—	—
	OHL Output Shaft (B)	834	—	—	—

(A) Contact Engineering

(B) OHL is for standard solid shaft diameters. Reference page 146 for optional shaft diameters. OHL's are applied at one shaft diameter from the shaft shoulder. OHL is calculated for the maximum reducer rating.

Larger OHL's may be applied under certain conditions and are subject to application engineering review.

Blank areas (—) indicate configuration not available

H50 Reducer
 900 Series Single Reduction
 900 Series Double Reduction
 Accessories
 Ratio Multipliers
 In-Line Helical (ILH)
 Universal Series Single Reduction
 Universal Series Double Reduction
 Engineering

In-Line Helical Reducer (ILH)

Size: 382

Service Factor 1.0 – Clamp Collar / 3 Pc Coupled / Separate DOUBLE REDUCTION

NEMA Motor Frame IEC Motor Frame Separate Group		56C 71D 71			— 80D 80			140TC 90D 90			180TC 100D 100		
Ratio	Output Rating Data	3450	1750	1160	3450	1750	1160	3450	1750	1160	3450	1750	1160
4.77	Output RPM	723	367	243	723	367	243	723	367	243	723	367	243
	Input HP (Max)	3.98	2.02	1.34	4.85	2.46	1.63	9.87	5.01	3.32	10.80	7.19	5.05
	Output Torque, In-Lb	347	347	347	422	422	422	860	860	860	941	1236	1308
	OHL Input Shaft	(A)	218	227	(A)	346	360	(A)	456	474	(A)	714	742
	OHL Output Shaft (B)	(A)	518	279	(A)	518	279	(A)	518	279	(A)	518	279
5.55	Output RPM	622	315	209	622	315	209	622	315	209	622	315	209
	Input HP (Max)	3.98	2.02	1.34	4.85	2.46	1.63	9.86	5.00	3.32	10.21	6.80	4.77
	Output Torque, In-Lb	404	404	403	491	491	491	1000	1000	1000	1035	1360	1439
	OHL Input Shaft	(A)	217	226	(A)	346	360	(A)	456	473	(A)	714	742
	OHL Output Shaft (B)	(A)	518	279	(A)	518	279	(A)	518	279	(A)	518	279
6.16	Output RPM	560	284	188	560	284	188	560	284	188	560	284	188
	Input HP (Max)	3.98	2.02	1.34	4.84	2.46	1.63	9.54	5.00	3.32	9.54	6.36	4.46
	Output Torque, In-Lb	448	448	448	545	545	545	1073	1110	1110	1073	1410	1493
	OHL Input Shaft	(A)	219	228	(A)	346	360	(A)	456	471	(A)	714	742
	OHL Output Shaft (B)	(A)	518	279	(A)	518	279	(A)	518	279	(A)	518	279
6.71	Output RPM	514	261	173	514	261	173	514	261	173	514	261	173
	Input HP (Max)	3.98	2.02	1.34	4.84	2.46	1.63	9.02	4.99	3.31	9.02	6.01	4.22
	Output Torque, In-Lb	488	488	488	594	594	594	1106	1205	1208	1106	1452	1537
	OHL Input Shaft	(A)	219	228	(A)	346	360	(A)	454	474	(A)	714	743
	OHL Output Shaft (B)	(A)	518	279	(A)	518	279	(A)	518	279	(A)	518	279
7.50	Output RPM	460	233	155	460	233	155	460	233	155	460	233	155
	Input HP (Max)	3.98	2.02	1.34	4.85	2.46	1.63	8.39	4.75	3.28	8.39	5.59	3.92
	Output Torque, In-Lb	545	545	545	664	664	664	1149	1283	1338	1149	1509	1597
	OHL Input Shaft	(A)	218	227	(A)	346	360	(A)	454	474	(A)	714	743
	OHL Output Shaft (B)	(A)	279	416	(A)	279	416	(A)	279	416	(A)	279	416
7.52	Output RPM	459	233	154	459	233	154	459	233	154	459	233	154
	Input HP (Max)	3.98	2.02	1.34	4.85	2.46	1.63	8.63	5.00	3.32	8.63	5.75	4.03
	Output Torque, In-Lb	547	547	547	666	666	666	1185	1355	1355	1185	1556	1647
	OHL Input Shaft	(A)	218	227	(A)	346	360	(A)	456	474	(A)	710	737
	OHL Output Shaft (B)	(A)	279	416	(A)	279	416	(A)	279	416	(A)	279	416
8.75	Output RPM	394	200	133	394	200	133	394	200	133	394	200	133
	Input HP (Max)	3.98	2.02	1.34	4.84	2.46	1.63	7.81	5.00	3.32	7.81	5.20	3.65
	Output Torque, In-Lb	636	636	636	774	774	774	1248	1576	1576	1248	1639	1735
	OHL Input Shaft	(A)	217	226	(A)	346	360	(A)	456	473	(A)	711	739
	OHL Output Shaft (B)	518	279	416	518	279	416	518	279	416	518	279	416
9.70	Output RPM	356	180	120	356	180	120	356	180	120	356	180	120
	Input HP (Max)	3.98	2.02	1.34	4.85	2.46	1.63	7.29	4.86	3.32	7.29	4.86	3.41
	Output Torque, In-Lb	705	705	705	859	859	859	1292	1698	1748	1292	1698	1797
	OHL Input Shaft	(A)	219	228	(A)	346	360	(A)	455	471	(A)	712	740
	OHL Output Shaft (B)	518	279	416	518	279	416	518	279	416	518	279	416

(A) Contact Engineering

(B) OHL is for standard solid shaft diameters. Reference page 146 for optional shaft diameters. OHL's are applied at one shaft diameter from the shaft shoulder. OHL is calculated for the maximum reducer rating. Larger OHL's may be applied under certain conditions and are subject to application engineering review.

Blank areas (—) indicate configuration not available

H50
Reducer

900 Series
Single Reduction

900 Series
Double Reduction

Accessories

Ratio Multiplier

In-Line Helical (ILH)

Universal Series
Single Reduction

Universal Series
Double Reduction

Engineering

In-Line Helical Reducer (ILH)

Size: 382

**Service Factor 1.0 – Clamp Collar / 3 Pc Coupled / Separate
DOUBLE REDUCTION**

Ratio	NEMA Motor Frame IEC Motor Frame Separate Group	56C 71D 71			— 80D 80			140TC 90D 90			180TC 100D 100		
		3450	1750	1160	3450	1750	1160	3450	1750	1160	3450	1750	1160
10.57	Output RPM	326	166	110	326	166	110	326	166	110	326	166	110
	Input HP (Max)	3.98	2.02	1.34	4.84	2.46	1.63	6.89	4.59	3.22	6.89	4.59	3.22
	Output Torque, In-Lb	768	768	768	935	935	935	1330	1747	1849	1330	1747	1849
	OHL Input Shaft	(A)	219	228	(A)	346	360	(A)	456	470	(A)	712	740
	OHL Output Shaft (B)	518	279	416	518	279	416	518	279	416	518	279	416
11.82	Output RPM	292	148	98	292	148	98	292	148	98	292	148	98
	Input HP (Max)	3.98	2.02	1.34	4.84	2.46	1.63	6.39	4.26	2.99	6.39	4.26	2.99
	Output Torque, In-Lb	859	859	859	1046	1046	1046	1380	1813	1919	1380	1813	1919
	OHL Input Shaft	(A)	218	227	(A)	346	360	(A)	456	471	(A)	712	741
	OHL Output Shaft (B)	518	416	546	518	416	546	518	416	546	518	416	546
12.92	Output RPM	267	135	90	267	135	90	267	135	90	267	135	90
	Input HP (Max)	3.98	2.02	1.34	4.85	2.46	1.63	6.02	4.01	2.77	6.02	4.01	2.77
	Output Torque, In-Lb	939	939	939	1144	1144	1144	1421	1867	1947	1421	1867	1947
	OHL Input Shaft	(A)	217	226	(A)	346	360	(A)	456	472	(A)	713	741
	OHL Output Shaft (B)	518	416	546	518	416	546	518	416	546	518	416	546
14.18	Output RPM	243	123	82	243	123	82	243	123	82	243	123	82
	Input HP (Max)	3.91	2.02	1.34	4.85	2.46	1.63	5.66	3.77	2.53	5.66	3.77	2.53
	Output Torque, In-Lb	1013	1031	1031	1255	1255	1255	1465	1925	1947	1465	1925	1947
	OHL Input Shaft	(A)	218	227	(A)	345	359	(A)	456	473	(A)	713	742
	OHL Output Shaft (B)	279	416	546	279	416	546	279	416	546	279	416	546
15.64	Output RPM	221	112	74	221	112	74	221	112	74	221	112	74
	Input HP (Max)	3.65	1.98	1.34	4.84	2.46	1.63	5.29	3.46	2.29	5.29	3.46	2.29
	Output Torque, In-Lb	1041	1116	1137	1384	1384	1384	1512	1947	1947	1512	1947	1947
	OHL Input Shaft	(A)	217	226	(A)	345	359	(A)	457	474	(A)	713	743
	OHL Output Shaft (B)	279	416	546	279	416	546	279	416	546	279	416	546
17.33	Output RPM	199	101	67	199	101	67	199	101	67	199	101	67
	Input HP (Max)	3.38	1.84	1.26	4.85	2.46	1.63	4.94	3.12	2.07	4.94	3.12	2.07
	Output Torque, In-Lb	1071	1147	1189	1534	1534	1534	1563	1947	1947	1563	1947	1947
	OHL Input Shaft	(A)	218	227	(A)	344	358	(A)	457	474	(A)	714	743
	OHL Output Shaft (B)	279	416	546	279	416	546	279	416	546	279	416	546
19.64	Output RPM	176	89	59	176	89	59	176	89	59	176	89	59
	Input HP (Max)	3.08	1.67	1.15	4.53	2.46	1.63	4.53	2.75	1.82	4.53	2.75	1.82
	Output Torque, In-Lb	1105	1183	1226	1627	1738	1738	1627	1947	1947	1627	1947	1947
	OHL Input Shaft	(A)	218	227	(A)	344	358	(A)	454	475	(A)	714	743
	OHL Output Shaft (B)	279	546	881	279	546	881	279	546	881	279	546	881
21.67	Output RPM	159	81	54	159	81	54	159	81	54	159	81	54
	Input HP (Max)	2.85	1.55	1.06	4.24	2.37	1.63	4.24	2.49	1.65	4.24	2.49	1.65
	Output Torque, In-Lb	1129	1210	1254	1678	1848	1918	1678	1947	1947	1678	1947	1947
	OHL Input Shaft	(A)	218	227	(A)	343	356	(A)	454	475	(A)	714	743
	OHL Output Shaft (B)	416	546	881	416	546	881	416	546	881	416	546	881

(A) Contact Engineering

(B) OHL is for standard solid shaft diameters. Reference page 146 for optional shaft diameters. OHL's are applied at one shaft diameter from the shaft shoulder. OHL is calculated for the maximum reducer rating. Larger OHL's may be applied under certain conditions and are subject to application engineering review.

Blank areas (—) indicate configuration not available

H50 Reducer
900 Series Single Reduction
900 Series Double Reduction
Accessories
Ratio Multipliers
In-Line Helical (ILH)
Universal Series Single Reduction
Universal Series Double Reduction
Engineering

In-Line Helical Reducer (ILH)

Size: 382

Service Factor 1.0 – Clamp Collar / 3 Pc Coupled / Separate DOUBLE REDUCTION

NEMA Motor Frame IEC Motor Frame Separate Group		56C 71D 71			— 80D 80			140TC 90D 90			180TC 100D 100		
Ratio	Output Rating Data	3450	1750	1160	3450	1750	1160	3450	1750	1160	3450	1750	1160
24.50	Output RPM	141	71	47	141	71	47	141	71	47	—	—	—
	Input HP (Max)	2.59	1.41	0.97	3.90	2.21	1.46	3.90	2.21	1.46	—	—	—
	Output Torque, In-Lb	1158	1241	1286	1744	1947	1947	1744	1947	1947	—	—	—
	OHL Input Shaft (A)	(A)	218	227	(A)	343	357	(A)	455	475	—	—	—
	OHL Output Shaft (B)	416	546	881	416	546	881	416	546	881	—	—	—
27.97	Output RPM	123	63	41	123	63	41	123	63	41	—	—	—
	Input HP (Max)	2.32	1.26	0.87	3.56	1.93	1.28	3.56	1.93	1.28	—	—	—
	Output Torque, In-Lb	1187	1272	1318	1818	1947	1947	1818	1947	1947	—	—	—
	OHL Input Shaft (A)	(A)	219	227	(A)	344	358	(A)	455	476	—	—	—
	OHL Output Shaft (B)	416	881	881	416	881	881	416	881	881	—	—	—
31.80	Output RPM	108	55	36	108	55	36	108	55	36	—	—	—
	Input HP (Max)	2.09	1.13	0.78	3.26	1.70	1.13	3.26	1.70	1.13	—	—	—
	Output Torque, In-Lb	1213	1299	1346	1893	1947	1947	1893	1947	1947	—	—	—
	OHL Input Shaft (A)	(A)	219	228	(A)	345	359	(A)	456	476	—	—	—
	OHL Output Shaft (B)	416	881	1117	416	881	1117	416	881	1117	—	—	—
34.04	Output RPM	101	51	34	101	51	34	101	51	34	—	—	—
	Input HP (Max)	1.97	1.07	0.74	3.01	1.59	1.05	3.01	1.59	1.05	—	—	—
	Output Torque, In-Lb	1226	1313	1361	1871	1947	1947	1871	1947	1947	—	—	—
	OHL Input Shaft (A)	(A)	219	228	(A)	345	359	(A)	456	476	—	—	—
	OHL Output Shaft (B)	416	881	1117	416	881	1117	416	881	1117	—	—	—
39.24	Output RPM	88	45	30	88	45	30	—	—	—	—	—	—
	Input HP (Max)	1.74	0.95	0.65	1.93	1.38	0.72	—	—	—	—	—	—
	Output Torque, In-Lb	1250	1339	1388	1385	1947	1530	—	—	—	—	—	—
	OHL Input Shaft (A)	(A)	219	228	(A)	346	360	—	—	—	—	—	—
	OHL Output Shaft (B)	546	881	1117	546	881	1117	—	—	—	—	—	—
44.12	Output RPM	78	40	26	—	—	—	—	—	—	—	—	—
	Input HP (Max)	1.52	0.86	0.56	—	—	—	—	—	—	—	—	—
	Output Torque, In-Lb	1224	1359	1352	—	—	—	—	—	—	—	—	—
	OHL Input Shaft (A)	(A)	219	228	—	—	—	—	—	—	—	—	—
	OHL Output Shaft (B)	546	1117	1117	—	—	—	—	—	—	—	—	—

(A) Contact Engineering

(B) OHL is for standard solid shaft diameters. Reference page 146 for optional shaft diameters. OHL's are applied at one shaft diameter from the shaft shoulder. OHL is calculated for the maximum reducer rating. Larger OHL's may be applied under certain conditions and are subject to application engineering review. Blank areas (—) indicate configuration not available

H50
Reducer

900 Series
Single Reduction

900 Series
Double Reduction

Accessories

Ratio Multiplier

In-Line Helical (ILH)

Universal Series
Single Reduction

Universal Series
Double Reduction

Engineering

In-Line Helical Reducer (ILH)

Size: 383

**Service Factor 1.0 – Clamp Collar / 3 Pc Coupled / Separate
TRIPLE REDUCTION**

NEMA Motor Frame IEC Motor Frame Separate Group		56C 71D 71			— 80D 80			140TC 90D 90		
Ratio	Output Rating Data	3450	1750	1160	3450	1750	1160	3450	1750	1160
30.74	Output RPM	112	57	38	112	57	38	112	57	38
	Input HP (Max)	2.58	1.72	1.17	2.58	1.72	1.17	2.58	1.72	1.17
	Output Torque, In-Lb	1451	1905	1947	1451	1905	1947	1451	1905	1947
	OHL Input Shaft (A)		210	218	(A)	343	357	(A)	455	473
	OHL Output Shaft (B)	416	881	1117	416	881	1117	416	881	1117
33.82	Output RPM	102	52	34	102	52	34	102	52	34
	Input HP (Max)	2.42	1.60	1.06	2.42	1.60	1.06	2.42	1.60	1.06
	Output Torque, In-Lb	1493	1947	1947	1493	1947	1947	1493	1947	1947
	OHL Input Shaft (A)		210	219	(A)	344	358	(A)	455	473
	OHL Output Shaft (B)	416	881	1117	416	881	1117	416	881	1117
39.28	Output RPM	88	45	30	88	45	30	88	45	30
	Input HP (Max)	2.18	1.38	0.91	2.18	1.38	0.91	2.18	1.38	0.91
	Output Torque, In-Lb	1561	1947	1947	1561	1947	1947	1561	1947	1947
	OHL Input Shaft (A)		211	219	(A)	345	359	(A)	456	474
	OHL Output Shaft (B)	546	881	1117	546	881	1117	546	881	1117
42.53	Output RPM	81	41	27	81	41	27	81	41	27
	Input HP (Max)	2.06	1.27	0.84	2.06	1.27	0.84	2.06	1.27	0.84
	Output Torque, In-Lb	1599	1947	1947	1599	1947	1947	1599	1947	1947
	OHL Input Shaft (A)		211	219	(A)	345	359	(A)	456	475
	OHL Output Shaft (B)	546	881	1117	546	881	1117	546	881	1117
48.10	Output RPM	72	36	24	72	36	24	72	36	24
	Input HP (Max)	1.89	1.12	0.75	1.89	1.12	0.75	1.89	1.12	0.75
	Output Torque, In-Lb	1659	1947	1947	1659	1947	1947	1659	1947	1947
	OHL Input Shaft (A)		211	220	(A)	346	359	(A)	457	475
	OHL Output Shaft (B)	546	1117	1117	546	1117	1117	546	1117	1117
52.86	Output RPM	65	33	22	65	33	22	65	33	22
	Input HP (Max)	1.77	1.02	0.68	1.77	1.02	0.68	1.77	1.02	0.68
	Output Torque, In-Lb	1706	1947	1947	1706	1947	1947	1706	1947	1947
	OHL Input Shaft (A)		211	220	(A)	346	360	(A)	457	475
	OHL Output Shaft (B)	546	1117	1117	546	1117	1117	546	1117	1117
58.30	Output RPM	59	30	20	59	30	20	59	30	20
	Input HP (Max)	1.65	0.93	0.61	1.65	0.93	0.61	1.65	0.93	0.61
	Output Torque, In-Lb	1758	1947	1947	1758	1947	1947	1758	1947	1947
	OHL Input Shaft (A)		211	220	(A)	346	360	(A)	457	475
	OHL Output Shaft (B)	881	1117	1117	881	1117	1117	881	1117	1117
64.58	Output RPM	53	27	18	53	27	18	—	—	—
	Input HP (Max)	1.54	0.84	0.55	1.54	0.84	0.55	—	—	—
	Output Torque, In-Lb	1812	1947	1947	1812	1947	1947	—	—	—
	OHL Input Shaft (A)		211	220	(A)	346	360	—	—	—
	OHL Output Shaft (B)	881	1117	1117	881	1117	1117	—	—	—
71.91	Output RPM	48	24	16	48	24	16	—	—	—
	Input HP (Max)	1.43	0.75	0.50	1.43	0.75	0.50	—	—	—
	Output Torque, In-Lb	1873	1947	1947	1873	1947	1947	—	—	—
	OHL Input Shaft (A)		210	218	(A)	346	360	—	—	—
	OHL Output Shaft (B)	881	1117	1117	881	1117	1117	—	—	—

(A) Contact Engineering

(B) OHL is for standard solid shaft diameters. Reference page 146 for optional shaft diameters. OHL's are applied at one shaft diameter from the shaft shoulder. OHL is calculated for the maximum reducer rating. Larger OHL's may be applied under certain conditions and are subject to application engineering review.

Blank areas (—) indicate configuration not available

H50
Reducer

900 Series
Single Reduction

900 Series
Double Reduction

Accessories

Ratio Multipliers

In-Line Helical (ILH)

Universal Series
Single Reduction

Universal Series
Double Reduction

Engineering

In-Line Helical Reducer (ILH)

Size: 383

Service Factor 1.0 – Clamp Collar / 3 Pc Coupled / Separate TRIPLE REDUCTION

NEMA Motor Frame IEC Motor Frame Separate Group		56C 71D 71			— 80D 80			140TC 90D 90		
Ratio	Output Rating Data	3450	1750	1160	3450	1750	1160	3450	1750	1160
82.52	Output RPM	42	21	14	42	21	14	—	—	—
	Input HP (Max)	1.29	0.66	0.43	1.29	0.66	0.43	—	—	—
	Output Torque, In-Lb	1947	1947	1947	1947	1947	1947	—	—	—
	OHL Input Shaft (A)		210	218	(A)	346	360	—	—	—
	OHL Output Shaft (B)	881	1117	1117	881	1117	1117	—	—	—
91.34	Output RPM	38	19	13	38	19	13	—	—	—
	Input HP (Max)	1.17	0.59	0.39	1.17	0.59	0.39	—	—	—
	Output Torque, In-Lb	1947	1947	1947	1947	1947	1947	—	—	—
	OHL Input Shaft (A)		210	219	(A)	346	360	—	—	—
	OHL Output Shaft (B)	1117	1117	1117	1117	1117	1117	—	—	—
103.89	Output RPM	33	17	11	33	17	11	—	—	—
	Input HP (Max)	1.03	0.52	0.34	1.03	0.52	0.34	—	—	—
	Output Torque, In-Lb	1947	1947	1947	1947	1947	1947	—	—	—
	OHL Input Shaft (A)		211	219	(A)	346	360	—	—	—
	OHL Output Shaft (B)	1117	1117	1117	1117	1117	1117	—	—	—
118.55	Output RPM	29	15	10	29	15	10	—	—	—
	Input HP (Max)	0.90	0.46	0.30	0.90	0.46	0.30	—	—	—
	Output Torque, In-Lb	1947	1947	1947	1947	1947	1947	—	—	—
	OHL Input Shaft (A)		211	219	(A)	346	360	—	—	—
	OHL Output Shaft (B)	1117	1117	1117	1117	1117	1117	—	—	—
133.57	Output RPM	26	13	9	26	13	9	—	—	—
	Input HP (Max)	0.80	0.40	0.27	0.80	0.40	0.27	—	—	—
	Output Torque, In-Lb	1947	1947	1947	1947	1947	1947	—	—	—
	OHL Input Shaft (A)		211	219	(A)	346	360	—	—	—
	OHL Output Shaft (B)	1117	1117	1117	1117	1117	1117	—	—	—
149.26	Output RPM	23	12	8	23	12	8	—	—	—
	Input HP (Max)	0.71	0.36	0.24	0.71	0.36	0.24	—	—	—
	Output Torque, In-Lb	1947	1947	1947	1947	1947	1947	—	—	—
	OHL Input Shaft (A)		211	220	(A)	347	360	—	—	—
	OHL Output Shaft (B)	1117	1117	1117	1117	1117	1117	—	—	—
170.24	Output RPM	20	10	7	20	10	7	—	—	—
	Input HP (Max)	0.63	0.32	0.21	0.63	0.32	0.21	—	—	—
	Output Torque, In-Lb	1947	1947	1947	1947	1947	1947	—	—	—
	OHL Input Shaft (A)		211	220	(A)	347	360	—	—	—
	OHL Output Shaft (B)	1117	1117	1117	1117	1117	1117	—	—	—
191.75	Output RPM	18	9	6	—	—	—	—	—	—
	Input HP (Max)	0.56	0.28	0.19	—	—	—	—	—	—
	Output Torque, In-Lb	1947	1947	1947	—	—	—	—	—	—
	OHL Input Shaft (A)		211	220	—	—	—	—	—	—
	OHL Output Shaft (B)	1117	1117	1117	—	—	—	—	—	—

(A) Contact Engineering

(B) OHL is for standard solid shaft diameters. Reference page 146 for optional shaft diameters. OHL's are applied at one shaft diameter from the shaft shoulder. OHL is calculated for the maximum reducer rating. Larger OHL's may be applied under certain conditions and are subject to application engineering review.

Blank areas (—) indicate configuration not available

H50
Reducer

900 Series
Single Reduction

900 Series
Double Reduction

Accessories

Ratio Multiplier

In-Line Helical (ILH)

Universal Series
Single Reduction

Universal Series
Double Reduction

Engineering

In-Line Helical Reducer (ILH)

Size: 481

Service Factor 1.0 – Clamp Collar / 3 Pc Coupled / Separate SINGLE REDUCTION

NEMA Motor Frame IEC Motor Frame Separate Group		56C 71D 71	— 80D 80	140TC 90D 90	180TC 100D 100	— 112D 112
Ratio	Output Rating Data	1750	1750	1750	1750	1750
1.52	Output RPM	—	1151	1151	1151	1151
	Input HP (Max)	—	2.46	5.00	10.4	12.6
	Output Torque, In-Lb	—	135	274	567	692
	OHL Input Shaft	—	55	140	190	230
	OHL Output Shaft (B)	—	—	—	—	—
1.83	Output RPM	—	958	958	958	958
	Input HP (Max)	—	2.46	5.00	10.2	11.9
	Output Torque, In-Lb	—	162	329	673	780
	OHL Input Shaft	—	55	140	190	230
	OHL Output Shaft (B)	—	—	—	—	—
2.15	Output RPM	—	814	814	814	814
	Input HP (Max)	—	2.46	5.00	9.67	11.1
	Output Torque, In-Lb	—	190	387	749	861
	OHL Input Shaft	—	55	140	190	230
	OHL Output Shaft (B)	—	190	190	190	190
2.41	Output RPM	726	726	726	726	726
	Input HP (Max)	2.02	2.46	5.00	9.25	10.6
	Output Torque, In-Lb	175	213	434	803	917
	OHL Input Shaft	55	55	140	190	230
	OHL Output Shaft (B)	195	195	195	195	195
2.70	Output RPM	648	648	648	648	648
	Input HP (Max)	2.02	2.46	4.86	8.82	10.0
	Output Torque, In-Lb	196	239	473	857	976
	OHL Input Shaft	55	55	140	190	230
	OHL Output Shaft (B)	161	161	161	161	161
2.95	Output RPM	594	594	594	594	594
	Input HP (Max)	2.02	2.46	4.70	8.48	9.63
	Output Torque, In-Lb	214	261	499	900	1022
	OHL Input Shaft	55	55	140	190	230
	OHL Output Shaft (B)	124	124	124	124	124
3.24	Output RPM	541	541	541	541	541
	Input HP (Max)	2.02	2.46	4.51	8.13	9.22
	Output Torque, In-Lb	235	286	526	947	1075
	OHL Input Shaft	55	55	140	190	230
	OHL Output Shaft (B)	106	106	106	106	106
3.56	Output RPM	491	491	491	491	491
	Input HP (Max)	2.02	2.46	4.32	7.77	8.81
	Output Torque, In-Lb	259	315	554	996	1130
	OHL Input Shaft	55	55	140	190	230
	OHL Output Shaft (B)	99	99	99	99	99

(A) Contact Engineering

(B) OHL is for standard solid shaft diameters. Reference page 146 for optional shaft diameters. OHL's are applied at one shaft diameter from the shaft shoulder. OHL is calculated for the maximum reducer rating.

Larger OHL's may be applied under certain conditions and are subject to application engineering review.

Blank areas (—) indicate configuration not available

HSO Reducer

900 Series Single Reduction

900 Series Double Reduction

Accessories

Ratio Multipliers

In-Line Helical (ILH)

Universal Series Single Reduction

Universal Series Double Reduction

Engineering

In-Line Helical Reducer (ILH)

Size: 481

Service Factor 1.0 – Clamp Collar / 3 Pc Coupled / Separate SINGLE REDUCTION

NEMA Motor Frame IEC Motor Frame Separate Group		56C 71D 71	— 80D 80	140TC 90D 90	180TC 100D 100	— 112D 112
Ratio	Output Rating Data	1750	1750	1750	1750	1750
3.87	Output RPM	453	453	453	453	453
	Input HP (Max)	2.02	2.46	4.15	7.47	8.48
	Output Torque, In-Lb	281	342	579	1040	1181
	OHL Input Shaft	55	55	140	190	230
	OHL Output Shaft (B)	99	99	99	99	99
4.21	Output RPM	415	415	415	415	415
	Input HP (Max)	2.02	2.46	3.98	7.17	8.18
	Output Torque, In-Lb	306	373	604	1089	1241
	OHL Input Shaft	55	55	140	190	230
	OHL Output Shaft (B)	191	191	191	191	191
4.62	Output RPM	379	379	379	379	379
	Input HP (Max)	1.96	2.46	3.80	6.89	6.92
	Output Torque, In-Lb	325	408	632	1145	1151
	OHL Input Shaft	55	55	140	190	230
	OHL Output Shaft (B)	191	191	191	191	191
5.08	Output RPM	344	344	344	344	344
	Input HP (Max)	1.82	2.46	3.61	5.80	5.80
	Output Torque, In-Lb	334	450	662	1062	1062
	OHL Input Shaft	55	55	140	190	230
	OHL Output Shaft (B)	303	303	303	303	303
5.85	Output RPM	299	299	299	299	299
	Input HP (Max)	1.63	2.31	3.36	5.04	5.04
	Output Torque, In-Lb	343	487	706	1062	1062
	OHL Input Shaft	55	55	140	190	230
	OHL Output Shaft (B)	303	303	303	303	303
6.33	Output RPM	276	276	276	276	276
	Input HP (Max)	1.53	2.21	3.23	4.46	4.46
	Output Torque, In-Lb	348	504	736	1018	1018
	OHL Input Shaft	55	55	140	190	230
	OHL Output Shaft (B)	627	627	627	627	627
7.00	Output RPM	250	250	250	250	—
	Input HP (Max)	1.40	2.09	3.05	3.41	—
	Output Torque, In-Lb	354	526	768	859	—
	OHL Input Shaft	55	55	140	190	—
	OHL Output Shaft (B)	627	627	627	627	—
8.17	Output RPM	214	214	214	—	—
	Input HP (Max)	1.23	1.89	2.56	—	—
	Output Torque, In-Lb	363	557	752	—	—
	OHL Input Shaft	55	55	140	—	—
	OHL Output Shaft (B)	711	711	711	—	—

(A) Contact Engineering

(B) OHL is for standard solid shaft diameters. Reference page 146 for optional shaft diameters. OHL's are applied at one shaft diameter from the shaft shoulder. OHL is calculated for the maximum reducer rating. Larger OHL's may be applied under certain conditions and are subject to application engineering review.

Blank areas (—) indicate configuration not available

H50
Reducer

900 Series
Single Reduction

900 Series
Double Reduction

Accessories

Ratio Multiplier

In-Line Helical (ILH)

Universal Series
Single Reduction

Universal Series
Double Reduction

Engineering

In-Line Helical Reducer (ILH)

Size: 481

**Service Factor 1.0 – Clamp Collar / 3 Pc Coupled / Separate
SINGLE REDUCTION**

NEMA Motor Frame IEC Motor Frame Separate Group		56C 71D 71	— 80D 80	140TC 90D 90	180TC 100D 100	— 112D 112
Ratio	Output Rating Data	1750	1750	1750	1750	1750
9.09	Output RPM	193	193	193	—	—
	Input HP (Max)	1.12	1.73	1.73	—	—
	Output Torque, In-Lb	368	566	566	—	—
	OHL Input Shaft	55	55	140	—	—
	OHL Output Shaft (B)	711	711	711	—	—
10.00	Output RPM	175	175	175	—	—
	Input HP (Max)	1.03	1.66	1.97	—	—
	Output Torque, In-Lb	372	598	708	—	—
	OHL Input Shaft	55	55	140	—	—
	OHL Output Shaft (B)	826	826	826	—	—
11.30	Output RPM	155	155	—	—	—
	Input HP (Max)	0.93	1.20	—	—	—
	Output Torque, In-Lb	377	487	—	—	—
	OHL Input Shaft	55	55	—	—	—
	OHL Output Shaft (B)	826	826	—	—	—

(A) Contact Engineering

(B) OHL is for standard solid shaft diameters. Reference page 146 for optional shaft diameters. OHL's are applied at one shaft diameter from the shaft shoulder. OHL is calculated for the maximum reducer rating. Larger OHL's may be applied under certain conditions and are subject to application engineering review.

Blank areas (—) indicate configuration not available

HSO Reducer
900 Series Single Reduction
900 Series Double Reduction
Accessories
Ratio Multipliers
In-Line Helical (ILH)
Universal Series Single Reduction
Universal Series Double Reduction
Engineering

In-Line Helical Reducer (ILH)

Size: 482

Service Factor 1.0 – Clamp Collar / 3 Pc Coupled / Separate DOUBLE REDUCTION

NEMA Motor Frame IEC Motor Frame Separate Group		56C 71D 71			— 80D 80			140TC 90D 90			180TC 100D 100			— 112D 112		
Ratio	Output Rating Data	3450	1750	1160	3450	1750	1160	3450	1750	1160	3450	1750	1160	3450	1750	1160
4.28	Output RPM	—	—	—	806	409	271	806	409	271	806	409	271	806	409	271
	Input HP (Max)	—	—	—	4.85	2.46	1.63	9.87	5.01	3.32	20.44	10.37	6.87	22.81	13.88	9.20
	Output Torque, In-Lb	—	—	—	379	379	379	772	772	772	1598	1598	1598	1784	2139	2139
	OHL Input Shaft	—	—	—	(A)	346	360	(A)	453	471	(A)	711	740	(A)	840	875
	OHL Output Shaft (B)	—	—	—	(A)	896	904	(A)	896	904	(A)	896	904	(A)	896	904
5.15	Output RPM	—	—	—	670	340	225	670	340	225	670	340	225	670	340	225
	Input HP (Max)	—	—	—	4.84	2.46	1.63	9.85	5.00	3.31	20.41	10.35	6.86	21.22	12.88	8.54
	Output Torque, In-Lb	—	—	—	455	455	455	927	927	927	1920	1920	1920	1996	2390	2390
	OHL Input Shaft	—	—	—	(A)	346	360	(A)	454	473	(A)	708	737	(A)	840	875
	OHL Output Shaft (B)	—	—	—	(A)	904	919	(A)	904	919	(A)	904	919	(A)	904	919
6.06	Output RPM	—	—	—	569	289	191	569	289	191	569	289	191	569	289	191
	Input HP (Max)	—	—	—	4.84	2.46	1.63	9.86	5.00	3.32	19.70	10.36	6.86	19.70	10.95	7.26
	Output Torque, In-Lb	—	—	—	536	536	536	1092	1092	1092	2181	2260	2260	2181	2390	2390
	OHL Input Shaft	—	—	—	(A)	346	360	(A)	452	471	(A)	709	739	(A)	843	877
	OHL Output Shaft (B)	—	—	—	(A)	904	919	(A)	904	919	(A)	904	919	(A)	904	919
6.79	Output RPM	508	258	171	508	258	171	508	258	171	508	258	171	508	258	171
	Input HP (Max)	4.00	2.02	1.34	4.84	2.46	1.63	9.86	5.00	3.32	18.29	9.77	6.48	18.29	9.77	6.48
	Output Torque, In-Lb	494	494	494	601	601	601	1223	1223	1223	2269	2390	2390	2269	2390	2390
	OHL Input Shaft	(A)	209	217	(A)	346	360	(A)	456	474	(A)	709	739	(A)	844	878
	OHL Output Shaft (B)	904	904	919	(A)	904	919	(A)	904	919	(A)	904	919	(A)	904	919
6.90	Output RPM	—	—	—	500	254	168	500	254	168	500	254	168	500	254	168
	Input HP (Max)	—	—	—	4.84	2.46	1.63	9.86	5.00	3.32	16.59	10.35	6.86	16.59	11.05	7.75
	Output Torque, In-Lb	—	—	—	611	611	611	1243	1243	1243	2091	2573	2573	2091	2747	2907
	OHL Input Shaft	—	—	—	(A)	346	360	(A)	453	471	(A)	711	740	(A)	844	878
	OHL Output Shaft (B)	—	—	—	(A)	904	919	(A)	904	919	(A)	904	919	(A)	904	919
8.29	Output RPM	—	—	—	416	211	140	416	211	140	416	211	140	416	211	140
	Input HP (Max)	—	—	—	4.84	2.46	1.63	9.86	5.00	3.31	14.70	9.80	6.86	14.70	9.80	6.87
	Output Torque, In-Lb	—	—	—	734	734	734	1493	1493	1493	2226	2925	3091	2226	2925	3096
	OHL Input Shaft	—	—	—	(A)	343	360	(A)	454	473	(A)	710	737	(A)	837	878
	OHL Output Shaft (B)	—	—	—	(A)	919	937	(A)	919	937	(A)	919	937	(A)	919	937
9.76	Output RPM	—	—	—	353	179	119	353	179	119	353	179	119	353	179	119
	Input HP (Max)	—	—	—	4.84	2.46	1.63	9.86	5.00	3.32	13.19	8.79	6.17	13.19	8.79	6.17
	Output Torque, In-Lb	—	—	—	864	864	864	1758	1758	1758	2352	3090	3270	2352	3090	3270
	OHL Input Shaft	—	—	—	(A)	346	360	(A)	452	471	(A)	711	739	(A)	839	871
	OHL Output Shaft (B)	—	—	—	904	919	937	904	919	937	904	919	937	904	919	937
10.93	Output RPM	316	160	106	316	160	106	316	160	106	316	160	106	316	160	106
	Input HP (Max)	3.98	2.02	1.34	4.85	2.46	1.63	9.87	5.00	3.32	12.23	8.15	5.72	12.23	8.15	5.72
	Output Torque, In-Lb	795	795	795	968	968	968	1970	1970	1970	2442	3208	3396	2442	3208	3396
	OHL Input Shaft	(A)	209	218	(A)	346	360	(A)	456	474	(A)	712	740	(A)	840	872
	OHL Output Shaft (B)	904	919	937	904	919	937	904	919	937	904	919	937	904	919	937

(A) Contact Engineering
 (B) OHL is for standard solid shaft diameters. Reference page 146 for optional shaft diameters. OHL's are applied at one shaft diameter from the shaft shoulder.
 OHL is calculated for the maximum reducer rating. Larger OHL's may be applied under certain conditions and are subject to application engineering review.
 Blank areas (—) indicate configuration not available

H50 Reducer
 900 Series Single Reduction
 900 Series Double Reduction
 Accessories
 Ratio Multiplier
 In-Line Helical (ILH)
 Universal Series Single Reduction
 Universal Series Double Reduction
 Engineering

In-Line Helical Reducer (ILH)

Size: 482

Service Factor 1.0 – Clamp Collar / 3 Pc Coupled / Separate DOUBLE REDUCTION

Ratio	NEMA Motor Frame IEC Motor Frame Separate Group	56C			—			140TC			180TC			—		
		71D	71	71	80D	80	80	90D	90	90	100D	100	100	112D	112	112
12.25	Output RPM	282	143	95	282	143	95	282	143	95	282	143	95	282	143	95
	Input HP (Max)	3.98	2.02	1.34	4.85	2.46	1.63	9.87	5.00	3.32	11.33	7.55	5.30	11.33	7.55	5.30
	Output Torque, In-Lb	891	891	891	1085	1085	1085	2208	2208	2208	2535	3331	3525	2535	3331	3525
	OHL Input Shaft	(A)	209	217	(A)	346	360	(A)	456	474	(A)	712	740	(A)	837	873
	OHL Output Shaft (B)	904	937	1142	904	937	1142	904	937	1142	904	937	1142	904	937	1142
13.38	Output RPM	258	131	87	258	131	87	258	131	87	258	131	87	258	131	87
	Input HP (Max)	3.98	2.02	1.34	4.84	2.46	1.63	9.86	5.00	3.32	10.67	7.11	4.99	10.67	7.11	4.99
	Output Torque, In-Lb	973	973	973	1184	1184	1184	2410	2410	2410	2609	3427	3627	2609	3427	3627
	OHL Input Shaft	(A)	211	219	(A)	346	360	(A)	455	474	(A)	713	741	(A)	838	870
	OHL Output Shaft (B)	904	937	1142	904	937	1142	904	937	1142	904	937	1142	904	937	1142
14.68	Output RPM	235	119	79	235	119	79	235	119	79	235	119	79	235	119	79
	Input HP (Max)	3.98	2.02	1.34	4.85	2.46	1.63	9.87	5.00	3.32	10.03	6.68	4.69	10.03	6.68	4.69
	Output Torque, In-Lb	1068	1068	1068	1300	1300	1300	2646	2646	2646	2689	3532	3738	2689	3532	3738
	OHL Input Shaft	(A)	210	219	(A)	346	360	(A)	454	473	(A)	713	741	(A)	839	871
	OHL Output Shaft (B)	919	937	1142	919	937	1142	919	937	1142	919	937	1142	919	937	1142
16.17	Output RPM	213	108	72	213	108	72	213	108	72	213	108	72	213	108	72
	Input HP (Max)	3.98	2.02	1.34	4.84	2.46	1.63	9.39	5.00	3.32	9.39	6.26	4.39	9.39	6.26	4.39
	Output Torque, In-Lb	1176	1176	1176	1431	1431	1431	2774	2913	2913	2774	3643	3856	2774	3643	3856
	OHL Input Shaft	(A)	210	218	(A)	346	360	(A)	453	472	(A)	713	742	(A)	840	872
	OHL Output Shaft (B)	919	937	1142	919	937	1142	919	937	1142	919	937	1142	919	937	1142
17.55	Output RPM	197	100	66	197	100	66	197	100	66	197	100	66	197	100	66
	Input HP (Max)	3.98	2.02	1.34	4.84	2.46	1.63	8.88	4.86	3.32	8.88	5.91	4.15	8.88	5.91	4.15
	Output Torque, In-Lb	1276	1276	1276	1553	1553	1553	2846	3071	3162	2846	3738	3957	2846	3738	3957
	OHL Input Shaft	(A)	209	218	(A)	346	360	(A)	452	470	(A)	713	742	(A)	842	875
	OHL Output Shaft (B)	919	1142	1142	919	1142	1142	919	1142	1142	919	1142	1142	919	1142	1142
19.13	Output RPM	180	91	61	180	91	61	180	91	61	180	91	61	180	91	61
	Input HP (Max)	3.87	2.02	1.34	4.84	2.46	1.63	8.37	4.65	3.22	8.37	5.58	3.83	8.37	5.58	3.83
	Output Torque, In-Lb	1353	1391	1391	1693	1693	1693	2924	3206	3343	2924	3842	3983	2924	3842	3983
	OHL Input Shaft	(A)	210	218	(A)	346	359	(A)	452	472	(A)	714	742	(A)	841	874
	OHL Output Shaft (B)	919	1142	1517	919	1142	1517	919	1142	1517	919	1142	1517	919	1142	1517
20.95	Output RPM	165	84	55	165	84	55	165	84	55	165	84	55	165	84	55
	Input HP (Max)	3.61	1.96	1.34	4.84	2.46	1.63	7.87	4.44	3.07	7.87	5.24	3.50	7.87	5.24	3.50
	Output Torque, In-Lb	1383	1482	1523	1854	1854	1854	3011	3352	3495	3011	3954	3983	3011	3954	3983
	OHL Input Shaft	(A)	209	217	(A)	345	359	(A)	454	472	(A)	714	743	(A)	841	875
	OHL Output Shaft (B)	919	1142	1517	919	1142	1517	919	1142	1517	919	1142	1517	919	1142	1517
23.07	Output RPM	150	76	50	150	76	50	150	76	50	150	76	50	—	—	—
	Input HP (Max)	3.35	1.82	1.25	4.85	2.46	1.63	7.37	4.23	2.92	7.37	4.79	3.18	—	—	—
	Output Torque, In-Lb	1413	1514	1569	2042	2042	2042	3104	3512	3661	3104	3983	3983	—	—	—
	OHL Input Shaft	(A)	209	218	(A)	345	359	(A)	454	471	(A)	714	743	—	—	—
	OHL Output Shaft (B)	937	1142	1517	937	1142	1517	937	1142	1517	937	1142	1517	—	—	—

(A) Contact Engineering

(B) OHL is for standard solid shaft diameters. Reference page 146 for optional shaft diameters. OHL's are applied at one shaft diameter from the shaft shoulder.

OHL is calculated for the maximum reducer rating. Larger OHL's may be applied under certain conditions and are subject to application engineering review.

Blank areas (—) indicate configuration not available

H50 Reducer
900 Series Single Reduction
900 Series Double Reduction
Accessories
Ratio Multipliers
In-Line Helical (ILH)
Universal Series Single Reduction
Universal Series Double Reduction
Engineering

In-Line Helical Reducer (ILH)

Size: 482

**Service Factor 1.0 – Clamp Collar / 3 Pc Coupled / Separate
DOUBLE REDUCTION**

NEMA Motor Frame IEC Motor Frame Separate Group		56C 71D 71			— 80D 80			140TC 90D 90			180TC 100D 100			— 112D 112		
Ratio	Output Rating Data	3450	1750	1160	3450	1750	1160	3450	1750	1160	3450	1750	1160	3450	1750	1160
26.53	Output RPM	130	66	44	130	66	44	130	66	44	130	66	44	—	—	—
	Input HP (Max)	3.00	1.63	1.12	4.85	2.46	1.63	6.69	3.92	2.71	6.69	4.17	2.76	—	—	—
	Output Torque, In-Lb	1453	1557	1614	2348	2348	2348	3241	3749	3910	3241	3983	3983	—	—	—
	OHL Input Shaft (A)	210	217	(A)	344	358	(A)	453	471	(A)	714	743	(A)	—	—	—
	OHL Output Shaft (B)	937	1142	1517	937	1142	1517	937	1142	1517	937	1142	1517	—	—	—
28.74	Output RPM	120	61	40	120	61	40	120	61	40	120	61	40	—	—	—
	Input HP (Max)	2.81	1.53	1.05	4.85	2.46	1.63	6.33	3.77	2.55	6.33	3.85	2.55	—	—	—
	Output Torque, In-Lb	1475	1580	1638	2544	2544	2544	3324	3905	3983	3324	3983	3983	—	—	—
	OHL Input Shaft (A)	210	219	(A)	343	357	(A)	453	471	(A)	714	744	(A)	—	—	—
	OHL Output Shaft (B)	937	1517	1517	937	1517	1517	937	1517	1517	937	1517	1517	—	—	—
31.77	Output RPM	109	55	37	109	55	37	109	55	37	109	55	37	—	—	—
	Input HP (Max)	2.59	1.40	0.97	4.67	2.40	1.63	5.91	3.48	2.31	5.91	3.48	2.31	—	—	—
	Output Torque, In-Lb	1500	1607	1666	2712	2743	2812	3429	3983	3983	3429	3983	3983	—	—	—
	OHL Input Shaft (A)	210	218	(A)	343	356	(A)	453	472	(A)	715	744	(A)	—	—	—
	OHL Output Shaft (B)	937	1517	1884	937	1517	1884	937	1517	1884	937	1517	1884	—	—	—
37.06	Output RPM	93	47	31	93	47	31	93	47	31	—	—	—	—	—	—
	Input HP (Max)	2.27	1.23	0.85	4.24	2.17	1.53	5.31	2.98	1.98	—	—	—	—	—	—
	Output Torque, In-Lb	1536	1646	1706	2868	2902	3076	3598	3983	3983	—	—	—	—	—	—
	OHL Input Shaft (A)	210	217	(A)	343	360	(A)	455	473	—	—	—	—	—	—	—
	OHL Output Shaft (B)	1142	1517	1884	1142	1517	1884	1142	1517	1884	—	—	—	—	—	—
41.26	Output RPM	84	42	28	84	42	28	84	42	28	—	—	—	—	—	—
	Input HP (Max)	2.07	1.12	0.77	3.94	2.02	1.42	4.39	2.68	1.63	—	—	—	—	—	—
	Output Torque, In-Lb	1558	1670	1731	2970	3005	3186	3312	3983	3659	—	—	—	—	—	—
	OHL Input Shaft (A)	210	(A)	(A)	343	360	(A)	455	473	—	—	—	—	—	—	—
	OHL Output Shaft (B)	1142	1517	1884	1142	1517	1884	1142	1517	1884	—	—	—	—	—	—
45.38	Output RPM	76	39	26	76	39	26	76	39	26	—	—	—	—	—	—
	Input HP (Max)	1.90	1.03	0.71	3.19	1.91	1.19	3.19	2.44	1.19	—	—	—	—	—	—
	Output Torque, In-Lb	1577	1690	1752	2645	3120	2922	2645	3983	2922	—	—	—	—	—	—
	OHL Input Shaft (A)	211	(A)	(A)	343	360	(A)	456	474	—	—	—	—	—	—	—
	OHL Output Shaft (B)	1142	1884	1884	1142	1884	1884	1142	1884	1884	—	—	—	—	—	—
51.28	Output RPM	67	34	23	67	34	23	—	—	—	—	—	—	—	—	—
	Input HP (Max)	1.71	0.93	0.64	2.08	1.87	0.77	—	—	—	—	—	—	—	—	—
	Output Torque, In-Lb	1599	1713	1776	1945	3454	2149	—	—	—	—	—	—	—	—	—
	OHL Input Shaft (A)	211	(A)	(A)	346	360	—	—	—	—	—	—	—	—	—	—
	OHL Output Shaft (B)	1142	1884	1986	1142	1884	1884	—	—	—	—	—	—	—	—	—

(A) Contact Engineering
 (B) OHL is for standard solid shaft diameters. Reference page 146 for optional shaft diameters. OHL's are applied at one shaft diameter from the shaft shoulder.
 OHL is calculated for the maximum reducer rating. Larger OHL's may be applied under certain conditions and are subject to application engineering review.
 Blank areas (—) indicate configuration not available

H50 Reducer
 900 Series Single Reduction
 900 Series Double Reduction
 Accessories
 Ratio Multiplier
 In-Line Helical (ILH)
 Universal Series Single Reduction
 Universal Series Double Reduction
 Engineering

In-Line Helical Reducer (ILH)

Size: 483

**Service Factor 1.0 – Clamp Collar / 3 Pc Coupled / Separate
TRIPLE REDUCTION**

NEMA Motor Frame IEC Motor Frame Separate Group		56C 71D 71			— 80D 80			140TC 90D 90			180TC 100D 100		
Ratio	Output Rating Data	3450	1750	1160	3450	1750	1160	3450	1750	1160	3450	1750	1160
35.59	Output RPM	97	49	33	97	49	33	97	49	33	—	—	—
	Input HP (Max)	3.98	2.02	1.34	4.79	2.46	1.63	4.79	3.11	2.06	—	—	—
	Output Torque, In-Lb	2587	2587	2587	3114	3150	3150	3114	3983	3983	—	—	—
	OHL Input Shaft (A)		209	218	(A)	346	360	(A)	457	475	—	—	—
	OHL Output Shaft (B)	1142	1517	1884	1142	1517	1884	1142	1517	1884	—	—	—
41.38	Output RPM	83	42	28	83	42	28	83	42	28	—	—	—
	Input HP (Max)	3.98	2.02	1.34	4.36	2.46	1.63	4.36	2.67	1.77	—	—	—
	Output Torque, In-Lb	3009	3009	3009	3295	3663	3663	3295	3983	3983	—	—	—
	OHL Input Shaft (A)		211	219	(A)	346	360	(A)	457	475	—	—	—
	OHL Output Shaft (B)	1142	1517	1884	1142	1517	1884	1142	1517	1884	—	—	—
45.91	Output RPM	75	38	25	75	38	25	75	38	25	—	—	—
	Input HP (Max)	3.98	2.02	1.34	4.08	2.41	1.60	4.08	2.41	1.60	—	—	—
	Output Torque, In-Lb	3338	3338	3338	3418	3983	3983	3418	3983	3983	—	—	—
	OHL Input Shaft (A)		210	219	(A)	346	360	(A)	457	476	—	—	—
	OHL Output Shaft (B)	1142	1884	1884	1142	1884	1884	1142	1884	1884	—	—	—
50.00	Output RPM	69	35	23	69	35	23	69	35	23	—	—	—
	Input HP (Max)	3.83	2.02	1.34	3.83	2.21	1.47	3.83	2.21	1.47	—	—	—
	Output Torque, In-Lb	3497	3635	3635	3497	3983	3983	3497	3983	3983	—	—	—
	OHL Input Shaft (A)		210	219	(A)	346	360	(A)	457	476	—	—	—
	OHL Output Shaft (B)	1142	1884	1986	1142	1884	1986	1142	1884	1986	—	—	—
55.92	Output RPM	62	31	21	62	31	21	62	31	21	—	—	—
	Input HP (Max)	3.53	1.98	1.31	3.53	1.98	1.31	3.53	1.98	1.31	—	—	—
	Output Torque, In-Lb	3606	3983	3983	3606	3983	3983	3606	3983	3983	—	—	—
	OHL Input Shaft (A)		210	218	(A)	346	360	(A)	457	476	—	—	—
	OHL Output Shaft (B)	1517	1884	1986	1517	1884	1986	1517	1884	1986	—	—	—
61.14	Output RPM	56	29	19	56	29	19	56	29	19	—	—	—
	Input HP (Max)	3.31	1.81	1.20	3.31	1.81	1.20	3.31	1.81	1.20	—	—	—
	Output Torque, In-Lb	3698	3983	3983	3698	3983	3983	3698	3983	3983	—	—	—
	OHL Input Shaft (A)		210	219	(A)	346	360	(A)	457	476	—	—	—
	OHL Output Shaft (B)	1517	1884	1986	1517	1884	1986	1517	1884	1986	—	—	—
67.10	Output RPM	51	26	17	51	26	17	51	26	17	—	—	—
	Input HP (Max)	3.10	1.65	1.09	3.10	1.65	1.09	3.10	1.65	1.09	—	—	—
	Output Torque, In-Lb	3797	3983	3983	3797	3983	3983	3797	3983	3983	—	—	—
	OHL Input Shaft (A)		210	219	(A)	346	360	(A)	453	471	—	—	—
	OHL Output Shaft (B)	1517	1884	1986	1517	1884	1986	1517	1884	1986	—	—	—
73.99	Output RPM	47	24	16	47	24	16	47	24	16	—	—	—
	Input HP (Max)	2.89	1.49	0.99	2.89	1.49	0.99	2.89	1.49	0.99	—	—	—
	Output Torque, In-Lb	3905	3983	3983	3905	3983	3983	3905	3983	3983	—	—	—
	OHL Input Shaft (A)		211	219	(A)	346	360	(A)	453	472	—	—	—
	OHL Output Shaft (B)	1517	1986	1986	1517	1986	1986	1517	1986	1986	—	—	—
82.02	Output RPM	42	21	14	42	21	14	42	21	14	—	—	—
	Input HP (Max)	2.66	1.35	0.89	2.66	1.35	0.89	2.66	1.35	0.89	—	—	—
	Output Torque, In-Lb	3983	3983	3983	3983	3983	3983	3983	3983	3983	—	—	—
	OHL Input Shaft (A)		209	218	(A)	343	357	(A)	454	473	—	—	—
	OHL Output Shaft (B)	1517	1986	1986	1517	1986	1986	1517	1986	1986	—	—	—

(A) Contact Engineering

(B) OHL is for standard solid shaft diameters. Reference page 146 for optional shaft diameters. OHL's are applied at one shaft diameter from the shaft shoulder. OHL is calculated for the maximum reducer rating. Larger OHL's may be applied under certain conditions and are subject to application engineering review.

Blank areas (—) indicate configuration not available

HSO Reducer

900 Series Single Reduction

900 Series Double Reduction

Accessories

Ratio Multipliers

In-Line Helical (ILH)

Universal Series Single Reduction

Universal Series Double Reduction

Engineering

In-Line Helical Reducer (ILH)

Size: 483

Service Factor 1.0 – Clamp Collar / 3 Pc Coupled / Separate TRIPLE REDUCTION

NEMA Motor Frame IEC Motor Frame Separate Group		56C 71D 71			— 80D 80			140TC 90D 90			180TC 100D 100		
Ratio	Output Rating Data	3450	1750	1160	3450	1750	1160	3450	1750	1160	3450	1750	1160
92.91	Output RPM	37	19	12	37	19	12	37	19	12	—	—	—
	Input HP (Max)	2.35	1.19	0.79	2.35	1.19	0.79	2.35	1.19	0.79	—	—	—
	Output Torque, In-Lb	3983	3983	3983	3983	3983	3983	3983	3983	3983	—	—	—
	OHL Input Shaft (A)		209	218	(A)	344	358	(A)	455	473	—	—	—
	OHL Output Shaft (B)	1884	1986	1986	1884	1986	1986	1884	1986	1986	—	—	—
102.52	Output RPM	34	17	11	34	17	11	34	17	11	—	—	—
	Input HP (Max)	2.13	1.08	0.72	2.13	1.08	0.72	2.13	1.08	0.72	—	—	—
	Output Torque, In-Lb	3983	3983	3983	3983	3983	3983	3983	3983	3983	—	—	—
	OHL Input Shaft (A)		210	218	(A)	344	358	(A)	456	474	—	—	—
	OHL Output Shaft (B)	1884	1986	1986	1884	1986	1986	1884	1986	1986	—	—	—
115.91	Output RPM	30	15	10	30	15	10	30	15	10	—	—	—
	Input HP (Max)	1.88	0.95	0.63	1.88	0.95	0.63	1.88	0.95	0.63	—	—	—
	Output Torque, In-Lb	3983	3983	3983	3983	3983	3983	3983	3983	3983	—	—	—
	OHL Input Shaft (A)		210	219	(A)	345	359	(A)	456	474	—	—	—
	OHL Output Shaft (B)	1884	1986	1986	1884	1986	1986	1884	1986	1986	—	—	—
132.34	Output RPM	26	13	9	26	13	9	26	13	9	—	—	—
	Input HP (Max)	1.65	0.84	0.55	1.65	0.84	0.55	1.65	0.84	0.55	—	—	—
	Output Torque, In-Lb	3983	3983	3983	3983	3983	3983	3983	3983	3983	—	—	—
	OHL Input Shaft (A)		211	219	(A)	345	359	(A)	457	475	—	—	—
	OHL Output Shaft (B)	1884	1986	1986	1884	1986	1986	1884	1986	1986	—	—	—
150.48	Output RPM	23	12	8	23	12	8	—	—	—	—	—	—
	Input HP (Max)	1.45	0.73	0.49	1.45	0.73	0.49	—	—	—	—	—	—
	Output Torque, In-Lb	3983	3983	3983	3983	3983	3983	—	—	—	—	—	—
	OHL Input Shaft (A)		211	219	(A)	346	360	—	—	—	—	—	—
	OHL Output Shaft (B)	1986	1986	1986	1986	1986	1986	—	—	—	—	—	—
161.05	Output RPM	21	11	7	—	—	—	—	—	—	—	—	—
	Input HP (Max)	1.35	0.69	0.46	—	—	—	—	—	—	—	—	—
	Output Torque, In-Lb	3983	3983	3983	—	—	—	—	—	—	—	—	—
	OHL Input Shaft (A)		211	219	—	—	—	—	—	—	—	—	—
	OHL Output Shaft (B)	1986	1986	1986	—	—	—	—	—	—	—	—	—
185.66	Output RPM	19	9	6	—	—	—	—	—	—	—	—	—
	Input HP (Max)	1.17	0.60	0.39	—	—	—	—	—	—	—	—	—
	Output Torque, In-Lb	3983	3983	3983	—	—	—	—	—	—	—	—	—
	OHL Input Shaft (A)		211	220	—	—	—	—	—	—	—	—	—
	OHL Output Shaft (B)	1986	1986	1986	—	—	—	—	—	—	—	—	—
208.77	Output RPM	17	8	6	—	—	—	—	—	—	—	—	—
	Input HP (Max)	1.04	0.53	0.35	—	—	—	—	—	—	—	—	—
	Output Torque, In-Lb	3983	3983	3983	—	—	—	—	—	—	—	—	—
	OHL Input Shaft (A)		211	220	—	—	—	—	—	—	—	—	—
	OHL Output Shaft (B)	1986	1986	1986	—	—	—	—	—	—	—	—	—

(A) Contact Engineering

(B) OHL is for standard solid shaft diameters. Reference page 146 for optional shaft diameters. OHL's are applied at one shaft diameter from the shaft shoulder.

OHL is calculated for the maximum reducer rating. Larger OHL's may be applied under certain conditions and are subject to application engineering review.

Blank areas (—) indicate configuration not available

H50
Reducer

900 Series
Single Reduction

900 Series
Double Reduction

Accessories

Ratio Multiplier

In-Line Helical (ILH)

Universal Series
Single Reduction

Universal Series
Double Reduction

Engineering

In-Line Helical Reducer (ILH)

Size: 681

**Service Factor 1.0 – Clamp Collar / 3 Pc Coupled / Separate
SINGLE REDUCTION**

NEMA Motor Frame IEC Motor Frame Separate Group		56C 71D 71	— 80D 80	140TC 90D 90	180TC 100D 100	— 112D 112	210TC 132D 132
Ratio	Output Rating Data	1750	1750	1750	1750	1750	1750
1.41	Output RPM	—	—	—	1242	1242	1242
	Input HP (Max)	—	—	—	10.36	13.87	22.38
	Output Torque, In-Lb	—	—	—	526	704	1136
	OHL Input Shaft	—	—	—	190	230	390
	OHL Output Shaft (B)	—	—	—	—	—	—
1.70	Output RPM	—	—	—	1029	1029	1029
	Input HP (Max)	—	—	—	10.36	13.83	21.10
	Output Torque, In-Lb	—	—	—	634	847	1292
	OHL Input Shaft	—	—	—	190	230	390
	OHL Output Shaft (B)	—	—	—	—	—	—
2.04	Output RPM	—	858	858	858	858	858
	Input HP (Max)	—	2.46	5.00	10.36	13.07	19.74
	Output Torque, In-Lb	—	181	368	761	961	1450
	OHL Input Shaft	—	55	140	190	230	390
	OHL Output Shaft (B)	—	140	140	140	140	140
2.39	Output RPM	—	732	732	732	732	732
	Input HP (Max)	—	2.46	5.00	9.90	12.33	18.46
	Output Torque, In-Lb	—	212	431	852	1062	1590
	OHL Input Shaft	—	55	140	190	230	390
	OHL Output Shaft (B)	—	111	111	111	111	111
2.85	Output RPM	—	614	614	614	614	614
	Input HP (Max)	—	2.46	5.00	9.24	11.46	17.04
	Output Torque, In-Lb	—	252	514	948	1177	1749
	OHL Input Shaft	—	55	140	190	230	390
	OHL Output Shaft (B)	—	52	52	52	52	52
3.09	Output RPM	566	566	566	566	566	566
	Input HP (Max)	2.02	2.46	4.86	8.92	11.05	16.41
	Output Torque, In-Lb	225	274	541	993	1230	1827
	OHL Input Shaft	55	55	140	190	230	390
	OHL Output Shaft (B)	52	52	52	52	52	52
3.45	Output RPM	507	507	507	507	507	507
	Input HP (Max)	2.02	2.46	4.65	8.47	10.49	15.60
	Output Torque, In-Lb	251	305	577	1053	1303	1938
	OHL Input Shaft	55	55	140	190	230	390
	OHL Output Shaft (B)	68	68	68	68	68	68
3.74	Output RPM	468	468	468	468	468	468
	Input HP (Max)	2.02	2.46	4.48	8.15	10.09	15.05
	Output Torque, In-Lb	272	331	604	1096	1358	2026
	OHL Input Shaft	55	55	140	190	230	390
	OHL Output Shaft (B)	73	73	73	73	73	73

(A) Contact Engineering
 (B) OHL is for standard solid shaft diameters. Reference page 146 for optional shaft diameters. OHL's are applied at one shaft diameter from the shaft shoulder. OHL is calculated for the maximum reducer rating. Larger OHL's may be applied under certain conditions and are subject to application engineering review.
 Blank areas (—) indicate configuration not available

In-Line Helical Reducer (ILH)

Size: 681

Service Factor 1.0 – Clamp Collar / 3 Pc Coupled / Separate SINGLE REDUCTION

NEMA Motor Frame IEC Motor Frame Separate Group		56C 71D 71	— 80D 80	140TC 90D 90	180TC 100D 100	— 112D 112	210TC 132D 132
Ratio	Output Rating Data	1750	1750	1750	1750	1750	1750
4.24	Output RPM	413	413	413	413	413	413
	Input HP (Max)	2.02	2.46	4.22	7.64	9.47	13.35
	Output Torque, In-Lb	308	375	644	1166	1445	2036
	OHL Input Shaft	55	55	140	190	230	390
	OHL Output Shaft (B)	160	160	160	160	160	160
4.56	Output RPM	384	384	384	384	384	384
	Input HP (Max)	2.02	2.46	4.07	7.36	9.15	11.85
	Output Torque, In-Lb	332	404	668	1209	1503	1947
	OHL Input Shaft	55	55	140	190	230	390
	OHL Output Shaft (B)	160	160	160	160	160	160
4.93	Output RPM	355	355	355	355	355	355
	Input HP (Max)	2.02	2.46	3.90	7.06	8.81	11.21
	Output Torque, In-Lb	359	437	693	1255	1566	1191
	OHL Input Shaft	55	55	140	190	230	390
	OHL Output Shaft (B)	453	453	453	453	453	453
5.36	Output RPM	327	327	327	327	327	327
	Input HP (Max)	2.02	2.46	3.73	6.78	8.50	10.09
	Output Torque, In-Lb	389	474	720	1308	1641	1947
	OHL Input Shaft	55	55	140	190	230	390
	OHL Output Shaft (B)	453	453	453	453	453	453
5.92	Output RPM	295	295	295	295	295	295
	Input HP (Max)	1.93	2.46	3.53	6.44	7.88	7.88
	Output Torque, In-Lb	413	524	752	1375	1682	1682
	OHL Input Shaft	55	55	140	190	230	390
	OHL Output Shaft (B)	453	453	453	453	453	453
6.42	Output RPM	273	273	273	273	273	273
	Input HP (Max)	1.85	2.46	3.37	6.22	6.51	6.51
	Output Torque, In-Lb	428	568	779	1438	1505	1505
	OHL Input Shaft	55	55	140	190	230	390
	OHL Output Shaft (B)	657	657	657	657	657	657
7.23	Output RPM	242	242	242	242	242	—
	Input HP (Max)	1.73	2.32	3.16	5.10	5.10	—
	Output Torque, In-Lb	451	604	822	1328	1328	—
	OHL Input Shaft	55	55	140	190	230	—
	OHL Output Shaft (B)	657	657	657	657	657	—
7.92	Output RPM	221	221	221	221	221	—
	Input HP (Max)	1.65	2.19	3.00	5.28	5.28	—
	Output Torque, In-Lb	469	625	856	1505	1505	—
	OHL Input Shaft	55	55	140	190	230	—
	OHL Output Shaft (B)	1078	1078	1078	1078	1078	—

(A) Contact Engineering

(B) OHL is for standard solid shaft diameters. Reference page 146 for optional shaft diameters. OHL's are applied at one shaft diameter from the shaft shoulder. OHL is calculated for the maximum reducer rating. Larger OHL's may be applied under certain conditions and are subject to application engineering review.

Blank areas (—) indicate configuration not available

H50
Reducer

900 Series
Single Reduction

900 Series
Double Reduction

Accessories

Ratio Multiplier

In-Line Helical (ILH)

Universal Series
Single Reduction

Universal Series
Double Reduction

Engineering

In-Line Helical Reducer (ILH)

Size: 681

**Service Factor 1.0 – Clamp Collar / 3 Pc Coupled / Separate
SINGLE REDUCTION**

NEMA Motor Frame IEC Motor Frame Separate Group		56C 71D 71	— 80D 80	140TC 90D 90	180TC 100D 100	— 112D 112	210TC 132D 132
Ratio	Output Rating Data	1750	1750	1750	1750	1750	1750
8.82	Output RPM	198	198	198	198	—	—
	Input HP (Max)	1.55	2.06	2.81	4.18	—	—
	Output Torque, In-Lb	491	653	892	1328	—	—
	OHL Input Shaft	55	55	140	190	—	—
	OHL Output Shaft (B)	1078	1078	1078	1078	—	—
10.08	Output RPM	174	174	174	—	—	—
	Input HP (Max)	1.43	1.88	2.32	—	—	—
	Output Torque, In-Lb	518	684	841	—	—	—
	OHL Input Shaft	55	55	140	—	—	—
	OHL Output Shaft (B)	1366	1366	1366	—	—	—
11.18	Output RPM	157	157	157	—	—	—
	Input HP (Max)	1.33	1.75	2.02	—	—	—
	Output Torque, In-Lb	536	706	814	—	—	—
	OHL Input Shaft	55	55	140	—	—	—
	OHL Output Shaft (B)	1366	1366	1366	—	—	—
12.40	Output RPM	141	141	141	—	—	—
	Input HP (Max)	1.24	1.53	1.61	—	—	—
	Output Torque, In-Lb	553	684	717	—	—	—
	OHL Input Shaft	55	55	140	—	—	—
	OHL Output Shaft (B)	1366	1366	1366	—	—	—

(A) Contact Engineering

(B) OHL is for standard solid shaft diameters. Reference page 146 for optional shaft diameters. OHL's are applied at one shaft diameter from the shaft shoulder. OHL is calculated for the maximum reducer rating. Larger OHL's may be applied under certain conditions and are subject to application engineering review.

Blank areas (—) indicate configuration not available

HSO Reducer

900 Series Single Reduction

900 Series Double Reduction

Accessories

Ratio Multipliers

In-Line Helical (ILH)

Universal Series Single Reduction

Universal Series Double Reduction

Engineering

In-Line Helical Reducer (ILH)

Size: 682

**Service Factor 1.0 – Clamp Collar / 3 Pc Coupled / Separate
DOUBLE REDUCTION**

NEMA Motor Frame IEC Motor Frame Separate Group		56C 71D 71			— 80D 80			140TC 90D 90			180TC 100D 100			— 112D 112			210TC 132D 132		
Ratio	Output Rating Data	3450	1750	1160	3450	1750	1160	3450	1750	1160	3450	1750	1160	3450	1750	1160	3450	1750	1160
3.49	Output RPM	—	—	—	—	—	—	—	—	—	989	501	332	989	501	332	989	501	332
	Input HP (Max)	—	—	—	—	—	—	—	—	—	20.44	10.37	6.87	27.38	13.89	9.20	39.98	26.64	18.15
	Output Torque, In-Lb	—	—	—	—	—	—	—	—	—	1303	1303	1303	1745	1745	1745	2549	3349	3441
	OHL Input Shaft	—	—	—	—	—	—	—	—	—	(A)	713	742	(A)	843	877	(A)	948	986
	OHL Output Shaft (B)	—	—	—	—	—	—	—	—	—	(A)	1498	904	(A)	1498	904	(A)	1498	1466
4.22	Output RPM	—	—	—	—	—	—	—	—	—	818	415	275	818	415	275	818	415	275
	Input HP (Max)	—	—	—	—	—	—	—	—	—	20.40	10.35	6.86	27.31	13.85	9.18	37.46	24.96	17.08
	Output Torque, In-Lb	—	—	—	—	—	—	—	—	—	1573	1573	1573	2106	2106	2106	2888	3794	3915
	OHL Input Shaft	—	—	—	—	—	—	—	—	—	(A)	713	742	(A)	843	877	(A)	947	985
	OHL Output Shaft (B)	—	—	—	—	—	—	—	—	—	(A)	1473	1466	(A)	1473	1466	(A)	1473	1466
5.06	Output RPM	—	—	—	682	346	229	682	346	229	682	346	229	682	346	229	682	346	229
	Input HP (Max)	—	—	—	4.84	2.46	1.63	9.86	5.00	3.32	20.41	10.35	6.86	27.34	13.87	9.19	34.92	23.27	15.78
	Output Torque, In-Lb	—	—	—	448	448	448	912	912	912	1887	1887	1887	2527	2527	2527	3228	4241	4337
	OHL Input Shaft	—	—	—	(A)	346	360	(A)	453	471	(A)	711	740	(A)	840	875	(A)	947	985
	OHL Output Shaft (B)	—	—	—	(A)	1466	1057	(A)	1466	1057	(A)	1466	1057	(A)	1466	1057	(A)	1466	1057
5.93	Output RPM	—	—	—	582	295	196	582	295	196	582	295	196	582	295	196	582	295	196
	Input HP (Max)	—	—	—	4.85	2.46	1.63	9.86	5.00	3.32	20.42	10.36	6.87	27.34	13.87	9.19	32.62	20.31	13.46
	Output Torque, In-Lb	—	—	—	525	525	525	1069	1069	1069	2212	2212	2212	2962	2962	2962	3534	4337	4337
	OHL Input Shaft	—	—	—	(A)	346	360	(A)	454	472	(A)	707	737	(A)	836	872	(A)	952	992
	OHL Output Shaft (B)	—	—	—	(A)	1466	1057	(A)	1466	1057	(A)	1466	1057	(A)	1466	1057	(A)	1466	1057
6.72	Output RPM	—	—	—	—	—	—	—	—	—	513	260	173	513	260	173	513	260	173
	Input HP (Max)	—	—	—	—	—	—	—	—	—	20.42	10.36	6.87	27.34	13.87	9.19	37.03	24.68	17.31
	Output Torque, In-Lb	—	—	—	—	—	—	—	—	—	2507	2507	2507	3356	3356	3356	4546	5973	6320
	OHL Input Shaft	—	—	—	—	—	—	—	—	—	(A)	713	742	(A)	843	877	(A)	953	986
	OHL Output Shaft (B)	—	—	—	—	—	—	—	—	—	(A)	1466	1057	(A)	1466	1057	(A)	1466	1057
8.11	Output RPM	—	—	—	—	—	—	—	—	—	425	216	143	425	216	143	425	216	143
	Input HP (Max)	—	—	—	—	—	—	—	—	—	20.41	10.35	6.86	27.33	13.86	9.19	33.73	22.48	15.77
	Output Torque, In-Lb	—	—	—	—	—	—	—	—	—	3024	3024	3024	4049	4049	4049	4997	6565	6948
	OHL Input Shaft	—	—	—	—	—	—	—	—	—	(A)	713	742	(A)	843	877	(A)	954	985
	OHL Output Shaft (B)	—	—	—	—	—	—	—	—	—	(A)	1057	962	(A)	1057	962	(A)	1057	962
9.73	Output RPM	—	—	—	355	180	119	355	180	119	355	180	119	355	180	119	355	180	119
	Input HP (Max)	—	—	—	4.84	2.46	1.63	9.86	5.00	3.32	20.42	10.36	6.86	27.34	13.87	9.19	30.28	20.17	13.39
	Output Torque, In-Lb	—	—	—	861	861	861	1753	1753	1753	3629	3629	3629	4859	4859	4859	5382	7067	7081
	OHL Input Shaft	—	—	—	(A)	346	360	(A)	453	471	(A)	711	740	(A)	840	875	(A)	955	985
	OHL Output Shaft (B)	—	—	—	1466	1057	962	1466	1057	962	1466	1057	962	1466	1057	962	1466	1057	962
11.40	Output RPM	—	—	—	303	154	102	303	154	102	303	154	102	303	154	102	303	154	102
	Input HP (Max)	—	—	—	4.85	2.46	1.63	9.87	5.01	3.32	20.43	10.36	6.87	27.25	13.87	9.20	27.25	17.25	11.43
	Output Torque, In-Lb	—	—	—	1009	1009	1009	2055	2055	2055	4254	4254	4254	5676	5696	5696	5676	7081	7081
	OHL Input Shaft	—	—	—	(A)	346	360	(A)	454	472	(A)	707	737	(A)	836	872	(A)	957	992
	OHL Output Shaft (B)	—	—	—	1466	962	962	1466	962	962	1466	962	962	1466	962	962	1466	962	962

(A) Contact Engineering
 (B) OHL is for standard solid shaft diameters. Reference page 146 for optional shaft diameters. OHL's are applied at one shaft diameter from the shaft shoulder.
 OHL is calculated for the maximum reducer rating. Larger OHL's may be applied under certain conditions and are subject to application engineering review.
 Blank areas (—) indicate configuration not available

H50 Reducer
 900 Series Single Reduction
 900 Series Double Reduction
 Accessories
 Ratio Multiplier
 In-Line Helical (ILH)
 Universal Series Single Reduction
 Universal Series Double Reduction
 Engineering

In-Line Helical Reducer (ILH)

Size: 682

Service Factor 1.0 – Clamp Collar / 3 Pc Coupled / Separate

DOUBLE REDUCTION

NEMA Motor Frame IEC Motor Frame Separate Group	56C 71D 71			— 80D 80			140TC 90D 90			180TC 100D 100			— 112D 112			210TC 132D 132			
	Ratio	Output Rating Data	3450	1750	1160	3450	1750	1160	3450	1750	1160	3450	1750	1160	3450	1750	1160	3450	1750
13.59	Output RPM	—	—	—	254	129	85	254	129	85	254	129	85	254	129	85	254	129	85
	Input HP (Max)	—	—	—	4.85	2.46	1.63	9.86	5.00	3.32	20.42	10.36	6.87	24.22	13.74	9.19	24.22	14.47	9.59
	Output Torque, In-Lb	—	—	—	1203	1203	1203	2449	2449	2449	5070	5070	5070	6013	6726	6789	6013	7081	7081
	OHL Input Shaft	—	—	—	(A)	346	360	(A)	456	470	(A)	708	738	(A)	838	873	(A)	957	990
	OHL Output Shaft (B)	—	—	—	1466	962	1306	1466	962	1306	1466	962	1306	1466	962	1306	1466	962	1306
14.74	Output RPM	234	119	79	234	119	79	234	119	79	234	119	79	234	119	79	234	119	79
	Input HP (Max)	3.98	2.02	1.34	4.85	2.46	1.63	9.86	5.00	3.32	19.95	10.36	6.87	22.93	13.25	8.84	22.92	13.34	8.84
	Output Torque, In-Lb	1072	1072	1072	1305	1305	1305	2656	2656	2656	5373	5499	5499	6173	7031	7081	6173	7081	7081
	OHL Input Shaft	(A)	218	226	(A)	346	360	(A)	456	474	(A)	712	736	(A)	828	872	(A)	958	991
	OHL Output Shaft (B)	1057	962	1306	1057	962	1306	1057	962	1306	1057	962	1306	1057	962	1306	1057	962	1306
16.45	Output RPM	210	106	71	210	106	71	210	106	71	210	106	71	210	106	71	210	106	71
	Input HP (Max)	3.98	2.02	1.34	4.85	2.46	1.63	9.87	5.00	3.32	18.96	9.95	6.85	21.29	11.95	7.92	21.29	11.95	7.92
	Output Torque, In-Lb	1196	1196	1196	1456	1456	1456	2965	2965	2965	5698	5892	6123	6398	7081	7081	6398	7081	7081
	OHL Input Shaft	(A)	218	226	(A)	346	360	(A)	456	474	(A)	695	740	(A)	840	870	(A)	950	995
	OHL Output Shaft (B)	1057	962	1306	1057	962	1306	1057	962	1306	1057	962	1306	1057	962	1306	1057	962	1306
17.82	Output RPM	194	98	65	194	98	65	194	98	65	194	98	65	194	98	65	194	98	65
	Input HP (Max)	3.98	2.02	1.34	4.85	2.46	1.63	9.86	5.00	3.32	18.23	9.56	6.59	20.16	11.03	7.31	20.16	11.03	7.31
	Output Torque, In-Lb	1296	1296	1296	1577	1577	1577	3211	3211	3211	5936	6136	6378	6564	7081	7081	6564	7081	7081
	OHL Input Shaft	(A)	217	226	(A)	346	360	(A)	455	474	(A)	660	740	(A)	837	872	(A)	949	996
	OHL Output Shaft (B)	1057	1306	1306	1057	1306	1306	1057	1306	1306	1057	1306	1306	1057	1306	1306	1057	1306	1306
20.20	Output RPM	171	87	57	171	87	57	171	87	57	171	87	57	171	87	57	171	87	57
	Input HP (Max)	3.98	2.02	1.34	4.84	2.46	1.63	9.47	4.94	3.32	17.10	8.97	6.18	18.52	9.73	6.45	18.52	9.73	6.45
	Output Torque, In-Lb	1469	1469	1469	1788	1788	1788	3493	3593	3639	6309	6524	6781	6833	7081	7081	6833	7081	7081
	OHL Input Shaft	(A)	219	228	(A)	346	360	(A)	454	472	(A)	602	739	(A)	840	875	(A)	952	997
	OHL Output Shaft (B)	1057	1306	1940	1057	1306	1940	1057	1306	1940	1057	1306	1940	1057	1306	1940	1057	1306	1940
21.76	Output RPM	159	80	53	159	80	53	159	80	53	159	80	53	159	80	53	159	80	53
	Input HP (Max)	3.98	2.02	1.34	4.84	2.46	1.63	9.11	4.76	3.29	16.46	8.63	5.95	17.60	9.04	5.99	17.60	9.04	5.99
	Output Torque, In-Lb	1582	1582	1582	1926	1926	1926	3622	3727	3885	6542	6765	7032	6995	7081	7081	6995	7081	7081
	OHL Input Shaft	(A)	218	227	(A)	346	360	(A)	454	471	(A)	566	739	(A)	841	876	(A)	953	997
	OHL Output Shaft (B)	962	1306	1940	962	1306	1940	962	1306	1940	962	1306	1940	962	1306	1940	962	1306	1940
23.53	Output RPM	147	74	49	147	74	49	147	74	49	147	74	49	147	74	49	147	74	49
	Input HP (Max)	3.98	2.02	1.34	4.84	2.46	1.63	8.74	4.56	3.15	15.81	8.29	5.54	16.47	8.36	5.54	16.47	8.36	5.54
	Output Torque, In-Lb	1711	1711	1711	2082	2082	2082	3758	3867	4031	6794	7025	7081	7081	7081	7081	7081	7081	7081
	OHL Input Shaft	(A)	218	227	(A)	346	360	(A)	454	471	(A)	525	740	(A)	842	877	(A)	955	990
	OHL Output Shaft (B)	962	1306	1940	962	1306	1940	962	1306	1940	962	1306	1940	962	1306	1940	962	1306	1940
25.55	Output RPM	135	68	45	135	68	45	135	68	45	135	68	45	135	68	45	135	68	45
	Input HP (Max)	3.98	2.02	1.34	4.84	2.46	1.63	8.36	4.36	3.01	14.88	7.70	5.10	15.17	7.70	5.10	15.17	7.70	5.10
	Output Torque, In-Lb	1858	1858	1858	2261	2261	2261	3901	4014	4185	6943	7081	7081	7081	7081	7081	7081	7081	7081
	OHL Input Shaft	(A)	218	226	(A)	345	359	(A)	454	471	(A)	536	741	(A)	843	877	(A)	956	989
	OHL Output Shaft (B)	962	1306	1940	962	1306	1940	962	1306	1940	962	1306	1940	962	1306	1940	962	1306	1940

(A) Contact Engineering

(B) OHL is for standard solid shaft diameters. Reference page 146 for optional shaft diameters. OHL's are applied at one shaft diameter from the shaft shoulder.

OHL is calculated for the maximum reducer rating. Larger OHL's may be applied under certain conditions and are subject to application engineering review.

Blank areas (—) indicate configuration not available

H50
Reducer900 Series
Single Reduction900 Series
Double Reduction

Accessories

Ratio Multipliers

In-Line Helical (ILH)

Universal Series
Single ReductionUniversal Series
Double Reduction

Engineering

In-Line Helical Reducer (ILH)

Size: 682

Service Factor 1.0 – Clamp Collar / 3 Pc Coupled / Separate DOUBLE REDUCTION

Ratio	NEMA Motor Frame IEC Motor Frame Separate Group	56C 71D 71			— 80D 80			140TC 90D 90			180TC 100D 100			— 112D 112			210TC 132D 132		
		3450	1750	1160	3450	1750	1160	3450	1750	1160	3450	1750	1160	3450	1750	1160	3450	1750	1160
28.25	Output RPM	122	62	41	122	62	41	122	62	41	122	62	41	122	62	41	122	62	41
	Input HP (Max)	3.69	2.01	1.34	4.84	2.46	1.63	7.90	4.12	2.85	13.72	6.96	4.61	13.72	6.96	4.61	13.72	6.96	4.61
	Output Torque, In-Lb	1904	2040	2054	2500	2500	2500	4075	4195	4373	7081	7081	7081	7081	7081	7081	7081	7081	7081
	OHL Input Shaft (A)	(A)	217	226	(A)	345	359	(A)	454	471	(A)	566	742	(A)	843	878	(A)	957	992
	OHL Output Shaft (B)	962	1940	1940	962	1940	1940	962	1940	1940	962	1940	1940	962	1940	1940	962	1940	1940
30.60	Output RPM	113	57	38	113	57	38	113	57	38	113	57	38	113	57	38	113	57	38
	Input HP (Max)	3.46	1.88	1.29	4.85	2.46	1.63	7.55	3.94	2.73	12.67	6.43	4.26	12.67	6.43	4.26	12.67	6.43	4.26
	Output Torque, In-Lb	1934	2072	2147	2709	2709	2709	4222	4346	4531	7081	7081	7081	7081	7081	7081	7081	7081	7081
	OHL Input Shaft (A)	(A)	218	227	(A)	344	358	(A)	453	471	(A)	587	742	(A)	844	878	(A)	957	993
	OHL Output Shaft (B)	962	1940	2765	962	1940	2765	962	1940	2765	962	1940	2765	962	1940	2765	962	1940	2765
34.49	Output RPM	100	51	34	100	51	34	100	51	34	100	51	37	100	51	34	—	—	—
	Input HP (Max)	3.14	1.70	1.17	4.84	2.46	1.63	7.06	3.69	2.55	11.24	5.70	3.78	11.24	5.70	3.78	—	—	—
	Output Torque, In-Lb	1975	2116	2193	3052	3052	3052	4449	4582	4777	7081	7081	7081	7081	7081	7081	—	—	—
	OHL Input Shaft (A)	(A)	218	227	(A)	344	357	(A)	453	471	(A)	617	739	(A)	844	879	—	—	—
	OHL Output Shaft (B)	962	1940	2765	962	1940	2765	962	1940	2765	962	1940	2765	962	1940	2765	—	—	—
37.76	Output RPM	91	46	31	91	46	31	91	46	31	91	46	37	91	46	31	—	—	—
	Input HP (Max)	2.90	1.58	1.08	4.60	2.46	1.63	6.72	3.51	2.43	10.27	5.21	3.45	10.24	5.21	3.45	—	—	—
	Output Torque, In-Lb	2004	2146	2225	3176	3342	3342	4636	4773	4978	7081	7081	7081	7063	7081	7081	—	—	—
	OHL Input Shaft (A)	(A)	218	227	(A)	343	356	(A)	457	472	(A)	637	740	(A)	845	879	—	—	—
	OHL Output Shaft (B)	1306	1940	2765	1306	1940	2765	1306	1940	2765	1306	1940	2765	1306	1940	2765	—	—	—
42.06	Output RPM	82	42	28	82	42	28	82	42	28	82	42	37	—	—	—	—	—	—
	Input HP (Max)	2.65	1.44	0.99	4.31	2.36	1.55	6.29	3.29	2.27	7.77	4.67	2.89	—	—	—	—	—	—
	Output Torque, In-Lb	2036	2181	2260	3310	3576	3550	4834	4977	5189	5970	7081	6602	—	—	—	—	—	—
	OHL Input Shaft (A)	(A)	218	227	(A)	343	356	(A)	457	472	(A)	---	741	—	—	—	—	—	—
	OHL Output Shaft (B)	1306	1940	2765	1306	1940	2765	1306	1940	2765	1306	1940	2765	—	—	—	—	—	—
48.09	Output RPM	72	36	24	72	36	24	72	36	24	—	—	—	—	—	—	—	—	—
	Input HP (Max)	2.36	1.28	0.88	3.94	2.16	1.42	5.83	3.04	2.10	—	—	—	—	—	—	—	—	—
	Output Torque, In-Lb	2073	2220	2301	3463	3747	3715	5118	5272	5497	—	—	—	—	—	—	—	—	—
	OHL Input Shaft (A)	(A)	219	227	(A)	343	356	(A)	457	475	—	—	—	—	—	—	—	—	—
	OHL Output Shaft (B)	1306	2765	3091	1306	2765	3091	1306	2765	3091	—	—	—	—	—	—	—	—	—

(A) Contact Engineering

(B) OHL is for standard solid shaft diameters. Reference page 146 for optional shaft diameters. OHL's are applied at one shaft diameter from the shaft shoulder.

OHL is calculated for the maximum reducer rating. Larger OHL's may be applied under certain conditions and are subject to application engineering review.

Blank areas (—) indicate configuration not available

H50
Reducer

900 Series
Single Reduction

900 Series
Double Reduction

Accessories

Ratio Multiplier

In-Line Helical (ILH)

Universal Series
Single Reduction

Universal Series
Double Reduction

Engineering

In-Line Helical Reducer (ILH)

Size: 683

**Service Factor 1.0 – Clamp Collar / 3 Pc Coupled / Separate
TRIPLE REDUCTION**

H50 Reducer	Ratio	NEMA Motor Frame IEC Motor Frame Separate Group			56C 71D 71			80D 80			140TC 90D 90			180TC 100D 100			
		Output Rating Data	3450	1750	1160	3450	1750	1160	3450	1750	1160	3450	1750	1160	3450	1750	1160
900 Series Single Reduction	37.80	Output RPM	—	—	—	91	46	31	91	46	31	91	46	31	91	46	31
		Input HP (Max)	—	—	—	4.84	2.46	1.63	7.84	5.00	3.32	7.84	5.20	3.45	7.84	5.20	3.45
		Output Torque, In-Lb	—	—	—	3346	3346	3346	5415	6811	6811	5415	7081	7081	5415	7081	7081
		OHL Input Shaft	—	—	—	(A)	346	360	(A)	453	471	(A)	714	743	(A)	714	743
		OHL Output Shaft (B)	—	—	—	1306	1940	2765	1306	1940	2765	1306	1940	2765	1306	1940	2765
900 Series Double Reduction	45.41	Output RPM	—	—	—	76	39	26	76	39	26	76	39	26	76	39	26
		Input HP (Max)	—	—	—	4.85	2.46	1.63	6.97	4.33	2.87	6.97	4.33	2.87	6.97	4.33	2.87
		Output Torque, In-Lb	—	—	—	4019	4019	4019	5780	7081	7081	5780	7081	7081	5780	7081	7081
		OHL Input Shaft	—	—	—	(A)	346	360	(A)	455	473	(A)	715	744	(A)	715	744
		OHL Output Shaft (B)	—	—	—	1306	2765	2765	1306	2765	2765	1306	2765	2765	1306	2765	2765
Accessories	53.47	Output RPM	—	—	—	65	33	22	65	33	22	65	33	22	65	33	22
		Input HP (Max)	—	—	—	4.84	2.46	1.63	6.18	3.68	2.44	6.18	3.68	2.44	6.18	3.68	2.44
		Output Torque, In-Lb	—	—	—	4732	4732	4732	6039	7081	7081	6039	7081	7081	6039	7081	7081
		OHL Input Shaft	—	—	—	(A)	346	360	(A)	456	474	(A)	715	744	(A)	715	744
		OHL Output Shaft (B)	—	—	—	1306	2765	3091	1306	2765	3091	1306	2765	3091	1306	2765	3091
Ratio Multipliers	59.91	Output RPM	58	29	19	58	29	19	58	29	19	58	29	19	58	29	19
		Input HP (Max)	3.98	2.02	1.34	4.85	2.46	1.63	5.70	3.28	2.18	5.70	3.28	2.18	5.70	3.28	2.18
		Output Torque, In-Lb	4356	4356	4356	5303	5303	5303	6234	7081	7081	6234	7081	7081	6234	7081	7081
		OHL Input Shaft	(A)	218	227	(A)	346	360	(A)	456	475	(A)	715	744	(A)	715	744
		OHL Output Shaft (B)	1940	2765	3091	1940	2765	3091	1940	2765	3091	1940	2765	3091	1940	2765	3091
In-Line Helical (ILH)	67.14	Output RPM	51	26	17	51	26	17	51	26	17	51	26	17	51	26	17
		Input HP (Max)	3.98	2.02	1.34	4.85	2.46	1.63	5.25	2.93	1.94	5.25	2.93	1.94	5.25	2.93	1.94
		Output Torque, In-Lb	4882	4882	4882	5943	5943	5943	6440	7081	7081	6440	7081	7081	6440	7081	7081
		OHL Input Shaft	(A)	217	226	(A)	346	360	(A)	457	475	(A)	708	737	(A)	708	737
		OHL Output Shaft (B)	1940	2765	3091	1940	2765	3091	1940	2765	3091	1940	2765	3091	1940	2765	3091
Universal Series Single Reduction	73.30	Output RPM	47	24	16	47	24	16	47	24	16	47	24	16	47	24	16
		Input HP (Max)	3.98	2.02	1.34	4.84	2.46	1.63	4.93	2.68	1.78	4.93	2.68	1.78	4.93	2.68	1.78
		Output Torque, In-Lb	5329	5329	5329	6487	6487	6487	6606	7081	7081	6606	7081	7081	6606	7081	7081
		OHL Input Shaft	(A)	219	228	(A)	346	360	(A)	457	475	(A)	708	737	(A)	708	737
		OHL Output Shaft (B)	1940	3091	3091	1940	3091	3091	1940	3091	3091	1940	3091	3091	1940	3091	3091
Universal Series Double Reduction	80.46	Output RPM	43	22	14	43	22	14	43	22	14	43	22	14	43	22	14
		Input HP (Max)	3.98	2.02	1.34	4.62	2.44	1.62	4.62	2.44	1.62	4.62	2.44	1.62	4.62	2.44	1.62
		Output Torque, In-Lb	5850	5850	5850	6789	7081	7081	6789	7081	7081	6789	7081	7081	6789	7081	7081
		OHL Input Shaft	(A)	219	227	(A)	346	360	(A)	457	476	(A)	710	738	(A)	710	738
		OHL Output Shaft (B)	1940	3091	3170	1940	3091	3170	1940	3091	3170	1940	3091	3170	1940	3091	3170
Universal Series Double Reduction	88.59	Output RPM	39	20	13	39	20	13	39	20	13	—	—	—	—	—	—
		Input HP (Max)	3.98	2.02	1.34	4.32	2.22	1.47	4.32	2.22	1.47	—	—	—	—	—	—
		Output Torque, In-Lb	6441	6441	6441	6988	7081	7081	6988	7081	7081	—	—	—	—	—	—
		OHL Input Shaft	(A)	218	227	(A)	346	360	(A)	457	476	—	—	—	—	—	—
		OHL Output Shaft (B)	2765	3091	3170	2765	3091	3170	2765	3091	3170	—	—	—	—	—	—
Engineering	96.16	Output RPM	36	18	12	36	18	12	36	18	12	—	—	—	—	—	—
		Input HP (Max)	3.98	2.02	1.34	4.03	2.04	1.36	4.03	2.04	1.36	—	—	—	—	—	—
		Output Torque, In-Lb	6991	6991	6991	7081	7081	7081	7081	7081	7081	—	—	—	—	—	—
		OHL Input Shaft	(A)	217	226	(A)	346	360	(A)	457	476	—	—	—	—	—	—
		OHL Output Shaft (B)	2765	3091	3170	2765	3091	3170	2765	3091	3170	—	—	—	—	—	—
Engineering	104.80	Output RPM	33	17	11	33	17	11	33	17	11	—	—	—	—	—	—
		Input HP (Max)	3.70	1.88	1.24	3.70	1.88	1.24	3.70	1.88	1.24	—	—	—	—	—	—
		Output Torque, In-Lb	7081	7081	7081	7081	7081	7081	7081	7081	7081	—	—	—	—	—	—
		OHL Input Shaft	(A)	218	227	(A)	346	360	(A)	457	476	—	—	—	—	—	—
		OHL Output Shaft (B)	2765	3091	3170	2765	3091	3170	2765	3091	3170	—	—	—	—	—	—

(A) Contact Engineering
 (B) OHL is for standard solid shaft diameters. Reference page 146 for optional shaft diameters. OHL's are applied at one shaft diameter from the shaft shoulder.
 OHL is calculated for the maximum reducer rating. Larger OHL's may be applied under certain conditions and are subject to application engineering review.
 Blank areas (—) indicate configuration not available

In-Line Helical Reducer (ILH)

Size: 683

**Service Factor 1.0 – Clamp Collar / 3 Pc Coupled / Separate
TRIPLE REDUCTION**

NEMA Motor Frame IEC Motor Frame Separate Group		56C 71D 71			— 80D 80			140TC 90D 90			180TC 100D 100		
Ratio	Output Rating Data	3450	1750	1160	3450	1750	1160	3450	1750	1160	3450	1750	1160
114.78	Output RPM	30	15	10	30	15	10	30	15	10	—	—	—
	Input HP (Max)	3.38	1.71	1.14	3.38	1.71	1.14	3.38	1.71	1.14	—	—	—
	Output Torque, In-Lb	7081	7081	7081	7081	7081	7081	7081	7081	7081	—	—	—
	OHL Input Shaft	(A)	218	227	(A)	346	360	(A)	457	476	—	—	—
	OHL Output Shaft (B)	2765	3170	3170	2765	3170	3170	2765	3170	3170	—	—	—
126.41	Output RPM	27	14	9	27	14	9	27	14	9	—	—	—
	Input HP (Max)	3.07	1.56	1.03	3.07	1.56	1.03	3.07	1.56	1.03	—	—	—
	Output Torque, In-Lb	7081	7081	7081	7081	7081	7081	7081	7081	7081	—	—	—
	OHL Input Shaft	(A)	219	227	(A)	346	360	(A)	453	471	—	—	—
	OHL Output Shaft (B)	2765	3170	3170	2765	3170	3170	2765	3170	3170	—	—	—
145.38	Output RPM	24	12	8	24	12	8	24	12	8	—	—	—
	Input HP (Max)	2.67	1.35	0.90	2.67	1.35	0.90	2.67	1.35	0.90	—	—	—
	Output Torque, In-Lb	7081	7081	7081	7081	7081	7081	7081	7081	7081	—	—	—
	OHL Input Shaft	(A)	219	228	(A)	346	360	(A)	454	472	—	—	—
	OHL Output Shaft (B)	3091	3170	3170	3091	3170	3170	3091	3170	3170	—	—	—
157.50	Output RPM	22	11	7	22	11	7	22	11	7	—	—	—
	Input HP (Max)	2.46	1.25	0.83	2.46	1.25	0.83	2.46	1.25	0.83	—	—	—
	Output Torque, In-Lb	7081	7081	7081	7081	7081	7081	7081	7081	7081	—	—	—
	OHL Input Shaft	(A)	219	226	(A)	343	357	(A)	454	473	—	—	—
	OHL Output Shaft (B)	3091	3170	3170	3091	3170	3170	3091	3170	3170	—	—	—
174.08	Output RPM	20	10	7	20	10	7	20	10	7	—	—	—
	Input HP (Max)	2.23	1.13	0.75	2.23	1.13	0.75	2.23	1.13	0.75	—	—	—
	Output Torque, In-Lb	7081	7081	7081	7081	7081	7081	7081	7081	7081	—	—	—
	OHL Input Shaft	(A)	219	227	(A)	344	357	(A)	455	473	—	—	—
	OHL Output Shaft (B)	3091	3170	3170	3091	3170	3170	3091	3170	3170	—	—	—
203.09	Output RPM	17	9	6	17	9	6	17	9	6	—	—	—
	Input HP (Max)	1.91	0.97	0.64	1.91	0.97	0.64	1.91	0.97	0.64	—	—	—
	Output Torque, In-Lb	7081	7081	7081	7081	7081	7081	7081	7081	7081	—	—	—
	OHL Input Shaft	(A)	218	227	(A)	345	358	(A)	456	474	—	—	—
	OHL Output Shaft (B)	3091	3170	3170	3091	3170	3170	3091	3170	3170	—	—	—
226.07	Output RPM	15	8	5	15	8	5	15	8	5	—	—	—
	Input HP (Max)	1.71	0.87	0.58	1.71	0.87	0.58	1.71	0.87	0.58	—	—	—
	Output Torque, In-Lb	7081	7081	7081	7081	7081	7081	7081	7081	7081	—	—	—
	OHL Input Shaft	(A)	219	227	(A)	345	359	(A)	456	474	—	—	—
	OHL Output Shaft (B)	3170	3170	3170	3170	3170	3170	3170	3170	3170	—	—	—
248.68	Output RPM	14	7	5	14	7	5	14	7	5	—	—	—
	Input HP (Max)	1.56	0.79	0.52	1.56	0.79	0.52	1.56	0.79	0.52	—	—	—
	Output Torque, In-Lb	7081	7081	7081	7081	7081	7081	7081	7081	7081	—	—	—
	OHL Input Shaft	(A)	219	228	(A)	345	359	(A)	456	475	—	—	—
	OHL Output Shaft (B)	3170	3170	3170	3170	3170	3170	3170	3170	3170	—	—	—
281.01	Output RPM	12	6	4	12	6	4	—	—	—	—	—	—
	Input HP (Max)	1.38	0.70	0.46	1.38	0.70	0.46	—	—	—	—	—	—
	Output Torque, In-Lb	7081	7081	7081	7081	7081	7081	—	—	—	—	—	—
	OHL Input Shaft	(A)	219	228	(A)	346	359	—	—	—	—	—	—
	OHL Output Shaft (B)	3170	3170	3170	3170	3170	3170	—	—	—	—	—	—

(A) Contact Engineering

(B) OHL is for standard solid shaft diameters. Reference page 146 for optional shaft diameters. OHL's are applied at one shaft diameter from the shaft shoulder.

OHL is calculated for the maximum reducer rating. Larger OHL's may be applied under certain conditions and are subject to application engineering review.

Blank areas (—) indicate configuration not available

H50 Reducer
900 Series Single Reduction
900 Series Double Reduction
Accessories
Ratio Multiplier
In-Line Helical (ILH)
Universal Series Single Reduction
Universal Series Double Reduction
Engineering

In-Line Helical Reducer (ILH)

Size: H_881

**Service Factor 1.0 – Clamp Collar / 3 Pc Coupled / Separate
SINGLE REDUCTION**

NEMA MOTOR FRAME IEC MOTOR FRAME SEPARATE GROUP		140TC 90D 90	180TC 100D 100	— 112D 112	210TC 132D 132	250TC 160D 160
RATIO	OUTPUT RATING DATA	1750	1750	1750	1750	1750
1.71	Output RPM	—	—	1021	1021	1021
	Input HP (Max)	—	—	13.87	25.09	41.56
	Output Torque, In-Lb	—	—	856	1549	2566
	OHL Input Shaft	—	—	230	390	410
	OHL Output Shaft (B)	—	—	—	—	—
2.09	Output RPM	—	837	837	837	837
	Input HP (Max)	—	10.36	13.87	23.80	38.91
	Output Torque, In-Lb	—	780	1044	1792	2930
	OHL Input Shaft	—	190	230	390	410
	OHL Output Shaft (B)	—	—	—	—	—
2.45	Output RPM	—	714	714	714	714
	Input HP (Max)	—	10.36	13.87	22.58	36.58
	Output Torque, In-Lb	—	914	1224	1993	3228
	OHL Input Shaft	—	190	230	390	410
	OHL Output Shaft (B)	—	460	460	460	460
2.88	Output RPM	608	608	608	608	608
	Input HP (Max)	5.00	10.36	13.87	21.24	34.17
	Output Torque, In-Lb	519	1074	1438	2203	3544
	OHL Input Shaft	140	190	230	390	410
	OHL Output Shaft (B)	487	487	487	487	487
3.30	Output RPM	530	530	530	530	530
	Input HP (Max)	5.00	10.36	13.53	20.02	32.15
	Output Torque, In-Lb	595	1233	1610	2383	3826
	OHL Input Shaft	140	190	230	390	410
	OHL Output Shaft (B)	617	617	617	617	617
3.90	Output RPM	449	449	449	449	449
	Input HP (Max)	5.00	10.22	12.65	18.53	24.26
	Output Torque, In-Lb	703	1436	1777	2603	3408
	OHL Input Shaft	140	190	230	390	410
	OHL Output Shaft (B)	690	690	690	690	690
4.23	Output RPM	414	414	414	414	414
	Input HP (Max)	5.00	9.88	12.21	17.84	23.25
	Output Torque, In-Lb	762	1504	1858	2716	3540
	OHL Input Shaft	140	190	230	390	410
	OHL Output Shaft (B)	783	783	783	783	783
4.70	Output RPM	372	372	372	372	372
	Input HP (Max)	4.85	9.43	11.62	16.97	20.13
	Output Torque, In-Lb	822	1595	1967	2873	3408
	OHL Input Shaft	140	190	230	390	410
	OHL Output Shaft (B)	783	783	783	783	783
5.11	Output RPM	343	343	343	343	343
	Input HP (Max)	4.68	9.06	11.17	16.34	17.81
	Output Torque, In-Lb	860	1666	2054	3004	3275
	OHL Input Shaft	140	190	230	390	410
	OHL Output Shaft (B)	1221	1221	1221	1221	1221

(A) Contact Engineering

(B) OHL is for standard solid shaft diameters. Reference page 146 for optional shaft diameters. OHL's are applied at one shaft diameter from the shaft shoulder. OHL is calculated for the maximum reducer rating. Larger OHL's may be applied under certain conditions and are subject to application engineering review.

Blank areas (—) indicate configuration not available

In-Line Helical Reducer (ILH)

Size: H_881

Service Factor 1.0 – Clamp Collar / 3 Pc Coupled / Separate SINGLE REDUCTION

NEMA MOTOR FRAME IEC MOTOR FRAME SEPARATE GROUP		140TC 90D 90	180TC 100D 100	— 112D 112	210TC 132D 132	250TC 160D 160
RATIO	OUTPUT RATING DATA	1750	1750	1750	1750	1750
5.65	Output RPM	310	310	310	310	310
	Input HP (Max)	4.46	8.63	10.64	13.93	13.93
	Output Torque, In-Lb	906	1755	2164	2832	2832
	OHL Input Shaft	140	190	230	390	410
	OHL Output Shaft (B)	1221	1221	1221	1221	1221
6.06	Output RPM	289	289	289	289	289
	Input HP (Max)	4.30	8.34	10.30	11.35	11.35
	Output Torque, In-Lb	939	1820	2249	2478	2478
	OHL Input Shaft	140	190	230	390	410
	OHL Output Shaft (B)	1221	1221	1221	1221	1221
6.53	Output RPM	268	268	268	268	—
	Input HP (Max)	4.13	8.03	9.96	11.28	—
	Output Torque, In-Lb	972	1890	2434	2655	—
	OHL Input Shaft	140	190	230	390	—
	OHL Output Shaft (B)	1440	1440	1440	1440	—
7.07	Output RPM	247	247	247	247	—
	Input HP (Max)	3.96	7.74	9.64	10.08	—
	Output Torque, In-Lb	1008	1970	2454	2567	—
	OHL Input Shaft	140	190	230	390	—
	OHL Output Shaft (B)	1440	1440	1440	1440	—
7.69	Output RPM	228	228	228	228	—
	Input HP (Max)	3.78	7.45	7.83	7.83	—
	Output Torque, In-Lb	1047	2063	2168	2168	—
	OHL Input Shaft	140	190	230	390	—
	OHL Output Shaft (B)	1690	1690	1690	1690	—
8.42	Output RPM	208	208	208	208	—
	Input HP (Max)	3.59	7.15	7.15	7.15	—
	Output Torque, In-Lb	1089	2168	2168	2168	—
	OHL Input Shaft	140	190	230	390	—
	OHL Output Shaft (B)	1690	1690	1690	1690	—
9.46	Output RPM	185	185	185	—	—
	Input HP (Max)	3.37	5.45	5.45	—	—
	Output Torque, In-Lb	1147	1859	1859	—	—
	OHL Input Shaft	140	190	230	—	—
	OHL Output Shaft (B)	1690	1690	1690	—	—
10.33	Output RPM	169	169	169	—	—
	Input HP (Max)	3.21	5.47	5.47	—	—
	Output Torque, In-Lb	1195	2036	2036	—	—
	OHL Input Shaft	140	190	230	—	—
	OHL Output Shaft (B)	1882	1882	1882	—	—

(A) Contact Engineering

(B) OHL is for standard solid shaft diameters. Reference page 146 for optional shaft diameters. OHL's are applied at one shaft diameter from the shaft shoulder. OHL is calculated for the maximum reducer rating.

Larger OHL's may be applied under certain conditions and are subject to application engineering review.

Blank areas (—) indicate configuration not available

H50
Reducer

900 Series
Single Reduction

900 Series
Double Reduction

Accessories

Ratio Multiplier

In-Line Helical (ILH)

Universal Series
Single Reduction

Universal Series
Double Reduction

Engineering

In-Line Helical Reducer (ILH)

Size: 882

Service Factor 1.0 – Clamp Collar / 3 Pc Coupled / Separate

DOUBLE REDUCTION

Ratio	Output Rating Data	56C 71D 71			— 80D 80			140TC 90D 90			180TC 100D 100			— 112D 112		
		3450	1750	1160	3450	1750	1160	3450	1750	1160	3450	1750	1160	3450	1750	1160
4.87	Output RPM	—	—	—	—	—	—	708	359	238	708	359	238	708	359	238
	Input HP (Max)	—	—	—	—	—	—	27.33	13.86	9.19	56.18	30.17	20.32	89.61	45.45	30.13
	Output Torque, In-Lb	—	—	—	—	—	—	2432	2432	2432	4998	5292	5375	7972	7972	7972
	OHL Input Shaft	—	—	—	—	—	—	(A)	838	872	(A)	946	985	(A)	1378	1582
	OHL Output Shaft (B)	—	—	—	—	—	—	(A)	2656	2252	(A)	2656	2252	(A)	2656	2252
5.94	Output RPM	—	—	—	581	295	195	581	295	195	581	295	195	581	295	195
	Input HP (Max)	—	—	—	20.41	10.35	6.86	27.33	13.86	9.19	53.26	28.61	19.26	87.06	45.45	30.13
	Output Torque, In-Lb	—	—	—	2215	2215	2215	2966	2966	2966	5779	6121	6217	9447	9723	9723
	OHL Input Shaft	—	—	—	(A)	713	742	(A)	843	877	(A)	952	990	(A)	1319	1587
	OHL Output Shaft (B)	—	—	—	(A)	2656	2252	(A)	2656	2252	(A)	2656	2252	(A)	2656	2252
6.96	Output RPM	—	—	—	496	251	167	496	251	167	496	251	167	496	251	167
	Input HP (Max)	—	—	—	20.41	10.35	6.86	27.33	13.86	9.19	50.55	27.15	18.29	77.40	44.49	29.49
	Output Torque, In-Lb	—	—	—	2595	2595	2595	3475	3475	3475	6427	6806	6915	9841	11152	11152
	OHL Input Shaft	—	—	—	(A)	713	742	(A)	843	877	(A)	952	991	(A)	1256	1548
	OHL Output Shaft (B)	—	—	—	(A)	2656	2252	(A)	2656	2252	(A)	2656	2252	(A)	2656	2252
7.59	Output RPM	—	—	—	—	—	—	455	231	153	455	231	153	455	231	153
	Input HP (Max)	—	—	—	—	—	—	27.35	13.87	9.19	56.21	30.18	20.33	64.76	43.15	30.14
	Output Torque, In-Lb	—	—	—	—	—	—	3792	3792	3792	7794	8251	8382	8979	11796	12431
	OHL Input Shaft	—	—	—	—	—	—	(A)	838	872	(A)	946	985	(A)	1403	1582
	OHL Output Shaft (B)	—	—	—	—	—	—	(A)	2252	2954	(A)	2252	2954	(A)	2252	2954
9.26	Output RPM	—	—	—	373	189	125	373	189	125	373	189	125	373	189	125
	Input HP (Max)	—	—	—	20.42	10.36	6.86	27.34	13.87	9.19	53.27	28.62	19.27	56.08	37.37	26.21
	Output Torque, In-Lb	—	—	—	3454	3454	3454	4625	4625	4625	9011	9544	9694	9486	12464	13185
	OHL Input Shaft	—	—	—	(A)	713	742	(A)	843	877	(A)	952	991	(A)	1418	1587
	OHL Output Shaft (B)	—	—	—	2656	2252	2954	2656	2252	2954	2656	2252	2954	2656	2252	2954
10.85	Output RPM	—	—	—	318	161	107	318	161	107	318	161	107	318	161	107
	Input HP (Max)	—	—	—	20.42	10.36	6.87	27.34	13.87	9.19	50.28	27.16	18.29	50.28	33.51	23.50
	Output Torque, In-Lb	—	—	—	4047	4047	4047	5419	5419	5419	9966	10613	10784	9966	13095	13852
	OHL Input Shaft	—	—	—	(A)	711	741	(A)	843	877	(A)	952	991	(A)	1420	1577
	OHL Output Shaft (B)	—	—	—	2656	2252	2954	2656	2252	2954	2656	2252	2954	2656	2252	2954
12.75	Output RPM	271	137	91	271	137	91	271	137	91	271	137	91	271	137	91
	Input HP (Max)	9.87	5.00	3.32	20.42	10.36	6.87	27.35	13.87	9.20	45.20	25.55	17.21	45.20	30.13	21.12
	Output Torque, In-Lb	2298	2298	2298	4757	4757	4757	6370	6370	6370	10529	11734	11924	10529	13834	14631
	OHL Input Shaft	(A)	453	471	(A)	709	738	(A)	841	876	(A)	950	989	(A)	1419	1580
	OHL Output Shaft (B)	2656	2954	3437	2656	2954	3437	2656	2954	3437	2656	2954	3437	2656	2954	3437
14.63	Output RPM	236	120	79	236	120	79	236	120	79	236	120	79	236	120	79
	Input HP (Max)	9.87	5.00	3.32	20.42	10.36	6.87	27.35	13.87	9.19	41.40	24.09	16.22	41.40	27.60	18.71
	Output Torque, In-Lb	2637	2637	2637	5458	5458	5458	7309	7309	7309	11064	12691	12895	11064	14540	14870
	OHL Input Shaft	(A)	454	473	(A)	710	740	(A)	838	873	(A)	948	987	(A)	1416	1586
	OHL Output Shaft (B)	2252	2954	3437	2252	2954	3437	2252	2954	3437	2252	2954	3437	2252	2954	3437

(A) Contact Engineering

(B) OHL is for standard solid shaft diameters. Reference page 146 for optional shaft diameters. OHL's are applied at one shaft diameter from the shaft shoulder.

OHL is calculated for the maximum reducer rating. Larger OHL's may be applied under certain conditions and are subject to application engineering review.

Blank areas (—) indicate configuration not available

In-Line Helical Reducer (ILH)

Size: 882

**Service Factor 1.0 – Clamp Collar / 3 Pc Coupled / Separate
DOUBLE REDUCTION**

NEMA Motor Frame IEC Motor Frame Separate Group		56C 71D 71			— 80D 80			140TC 90D 90			180TC 100D 100			— 112D 112		
Ratio	Output Rating Data	3450	1750	1160	3450	1750	1160	3450	1750	1160	3450	1750	1160	3450	1750	1160
17.27	Output RPM	200	101	67	200	101	67	200	101	67	200	101	67	200	101	67
	Input HP (Max)	9.86	5.00	3.32	20.42	10.36	6.87	27.34	13.87	9.19	37.25	22.29	15.01	37.25	23.91	15.85
	Output Torque, In-Lb	3112	3112	3112	6442	6442	6442	8626	8626	8626	11752	13865	14087	11752	14870	14870
	OHL Input Shaft	(A)	452	470	(A)	707	737	(A)	839	874	(A)	946	985	(A)	1426	1591
	OHL Output Shaft (B)	2252	2954	3437	2252	2954	3437	2252	2954	3437	2252	2954	3437	2252	2954	3437
18.72	Output RPM	184	93	62	184	93	62	184	93	62	184	93	62	184	93	62
	Input HP (Max)	9.86	5.00	3.32	20.42	10.36	6.87	27.34	13.87	9.19	34.92	21.46	14.45	34.92	22.06	14.62
	Output Torque, In-Lb	3373	3373	3373	6983	6983	6983	9350	9350	9350	11941	14468	14701	11942	14870	14870
	OHL Input Shaft	(A)	456	474	(A)	638	741	(A)	757	872	(A)	956	995	(A)	1437	1593
	OHL Output Shaft (B)	2252	3437	3437	2252	3437	3437	2252	3437	3437	2252	3437	3437	2252	3437	3437
20.81	Output RPM	166	84	56	166	84	56	166	84	56	166	84	56	166	84	56
	Input HP (Max)	9.86	5.00	3.32	20.42	10.36	6.87	26.04	13.87	9.19	32.10	19.84	13.15	32.10	19.84	13.15
	Output Torque, In-Lb	3750	3750	3750	7764	7764	7764	9899	10396	10396	12202	14870	14869	12202	14870	14870
	OHL Input Shaft	(A)	456	474	(A)	522	739	(A)	587	876	(A)	956	987	(A)	1447	1594
	OHL Output Shaft (B)	2252	3437	4471	2252	3437	4471	2252	3437	4471	2252	3437	4471	2252	3437	4471
22.61	Output RPM	153	77	51	153	77	51	153	77	51	153	77	51	153	77	51
	Input HP (Max)	9.86	5.00	3.32	20.14	10.36	6.86	25.02	13.39	9.04	30.07	18.26	12.10	30.07	18.26	12.10
	Output Torque, In-Lb	4074	4074	4074	8319	8433	8433	10333	10901	11110	12421	14870	14869	12422	14870	14870
	OHL Input Shaft	(A)	455	474	(A)	408	709	(A)	519	874	(A)	949	989	(A)	1454	1595
	OHL Output Shaft (B)	2954	3437	4471	2954	3437	4471	2954	3437	4471	2954	3437	4471	2954	3437	4471
25.01	Output RPM	138	70	46	138	70	46	138	70	46	138	70	46	138	70	46
	Input HP (Max)	9.86	5.00	3.32	18.62	10.13	6.86	23.65	12.75	8.62	27.80	16.51	10.94	27.80	16.51	10.94
	Output Torque, In-Lb	4506	4506	4506	8507	9122	9328	10803	11487	11707	12700	14870	14869	12700	14870	14870
	OHL Input Shaft	(A)	454	473	(A)	402	674	(A)	444	795	(A)	951	987	(A)	1462	1596
	OHL Output Shaft (B)	2954	3437	4471	2954	3437	4471	2954	3437	4471	2954	3437	4471	2954	3437	4471
26.85	Output RPM	128	65	43	128	65	43	128	65	43	128	65	43	128	65	43
	Input HP (Max)	9.63	5.00	3.32	17.60	9.57	6.58	22.28	12.35	8.34	26.29	15.38	10.19	26.29	15.38	10.19
	Output Torque, In-Lb	4725	4838	4837	8631	9257	9606	10931	11940	12169	12896	14870	14869	12897	14870	14870
	OHL Input Shaft	(A)	453	472	(A)	396	666	(A)	381	733	(A)	948	989	(A)	1467	1596
	OHL Output Shaft (B)	2954	3437	4471	2954	3437	4471	2954	3437	4471	2954	3437	4471	2954	3437	4471
28.93	Output RPM	119	60	40	119	60	40	119	60	40	119	60	40	—	—	—
	Input HP (Max)	9.26	4.83	3.32	16.57	9.01	6.20	20.93	11.94	8.06	24.84	14.27	9.46	—	—	—
	Output Torque, In-Lb	4894	5036	5213	8756	9391	9743	11060	12438	12677	13127	14870	14869	—	—	—
	OHL Input Shaft	(A)	452	470	(A)	391	660	(A)	312	664	(A)	951	991	—	—	—
	OHL Output Shaft (B)	2954	4471	4856	2954	4471	4856	2954	4471	4856	2954	4471	4856	—	—	—
31.32	Output RPM	110	56	37	110	56	37	110	56	37	110	56	37	—	—	—
	Input HP (Max)	8.87	4.63	3.20	15.52	8.45	5.81	19.55	11.55	7.80	23.37	13.18	8.74	—	—	—
	Output Torque, In-Lb	5073	5221	5443	8882	9526	9882	11183	13027	13277	13370	14870	14869	—	—	—
	OHL Input Shaft	(A)	452	472	(A)	385	653	(A)	227	577	(A)	953	992	—	—	—
	OHL Output Shaft (B)	2954	4471	4856	2954	4471	4856	2954	4471	4856	2954	4471	4856	—	—	—

(A) Contact Engineering

(B) OHL is for standard solid shaft diameters. Reference page 146 for optional shaft diameters. OHL's are applied at one shaft diameter from the shaft shoulder.

OHL is calculated for the maximum reducer rating. Larger OHL's may be applied under certain conditions and are subject to application engineering review.

Blank areas (—) indicate configuration not available

In-Line Helical Reducer (ILH)

Size: 882

**Service Factor 1.0 – Clamp Collar / 3 Pc Coupled / Separate
DOUBLE REDUCTION**

NEMA Motor Frame IEC Motor Frame Separate Group		56C 71D 71			— 80D 80			140TC 90D 90			180TC 100D 100			— 112D 112		
Ratio	Output Rating Data	3450	1750	1160	3450	1750	1160	3450	1750	1160	3450	1750	1160	3450	1750	1160
34.07	Output RPM	101	51	34	101	51	34	101	51	34	101	51	34	—	—	—
	Input HP (Max)	8.46	4.42	3.05	14.47	7.87	5.42	18.17	10.96	7.55	21.92	12.12	8.03	—	—	—
	Output Torque, In-Lb	5267	5421	5651	9007	9661	10025	11310	13450	13974	13640	14870	14869	—	—	—
	OHL Input Shaft	(A)	454	472	(A)	379	650	(A)	176	474	(A)	954	994	—	—	—
	OHL Output Shaft (B)	2954	4471	4856	2954	4471	4856	2954	4471	4856	2954	4471	4856	—	—	—
37.27	Output RPM	93	47	31	93	47	31	93	47	31	93	47	31	—	—	—
	Input HP (Max)	8.05	4.20	2.90	13.42	7.30	5.02	16.80	10.16	6.99	18.13	11.08	6.75	—	—	—
	Output Torque, In-Lb	5479	5640	5880	9134	9800	10168	11435	13638	14147	12341	14870	13671	—	—	—
	OHL Input Shaft	(A)	454	471	(A)	373	643	(A)	168	469	(A)	955	997	—	—	—
	OHL Output Shaft (B)	3437	4471	4856	3437	4471	4856	3437	4471	4856	3437	4471	4856	—	—	—
41.90	Output RPM	82	42	28	82	42	28	82	42	28	—	—	—	—	—	—
	Input HP (Max)	7.54	3.94	2.72	12.13	6.60	4.54	15.14	9.19	5.83	—	—	—	—	—	—
	Output Torque, In-Lb	5771	5941	6195	9286	9964	10336	11589	13862	13268	—	—	—	—	—	—
	OHL Input Shaft	(A)	453	471	(A)	369	641	(A)	160	665	—	—	—	—	—	—
	OHL Output Shaft (B)	3437	4471	4856	3437	4471	4856	3437	4471	4856	—	—	—	—	—	—
45.76	Output RPM	75	38	25	75	38	25	75	38	25	—	—	—	—	—	—
	Input HP (Max)	7.19	3.75	2.59	11.24	6.11	4.20	13.99	8.50	4.35	—	—	—	—	—	—
	Output Torque, In-Lb	6009	6187	6448	9392	10074	10454	11695	14015	10819	—	—	—	—	—	—
	OHL Input Shaft	(A)	453	474	(A)	364	743	(A)	157	876	—	—	—	—	—	—
	OHL Output Shaft (B)	3437	4856	4856	3437	4856	4856	3437	4856	4856	—	—	—	—	—	—
50.73	Output RPM	68	34	23	68	34	23	—	—	—	—	—	—	—	—	—
	Input HP (Max)	6.75	3.53	2.44	9.01	5.58	3.35	—	—	—	—	—	—	—	—	—
	Output Torque, In-Lb	6254	6441	6716	8352	10198	9230	—	—	—	—	—	—	—	—	—
	OHL Input Shaft	(A)	456	474	(A)	(A)	(A)	—	—	—	—	—	—	—	—	—
	OHL Output Shaft (B)	3437	4856	4856	3437	4856	4856	—	—	—	—	—	—	—	—	—

(A) Contact Engineering

(B) OHL is for standard solid shaft diameters. Reference page 146 for optional shaft diameters. OHL's are applied at one shaft diameter from the shaft shoulder.

OHL is calculated for the maximum reducer rating. Larger OHL's may be applied under certain conditions and are subject to application engineering review.

Blank areas (—) indicate configuration not available

H50
Reducer

900 Series
Single Reduction

900 Series
Double Reduction

Accessories

Ratio Multipliers

In-Line Helical (ILH)

Universal Series
Single Reduction

Universal Series
Double Reduction

Engineering

In-Line Helical Reducer (ILH)

Size: 883

**Service Factor 1.0 – Clamp Collar / 3 Pc Coupled / Separate
TRIPLE REDUCTION**

NEMA Motor Frame IEC Motor Frame Separate Group		56C 71D 71			— 80D 80			140TC 90D 90			180TC 100D 100			— 112D 112			210TC 132D 132		
Ratio	Output Rating Data	3450	1750	1160	3450	1750	1160	3450	1750	1160	3450	1750	1160	3450	1750	1160	3450	1750	1160
34.14	Output RPM	—	—	—	—	—	—	—	—	—	101	51	34	101	51	34	101	51	34
	Input HP (Max)	—	—	—	—	—	—	—	—	—	17.70	10.36	6.87	17.70	12.09	8.02	17.70	12.09	8.02
	Output Torque, In-Lb	—	—	—	—	—	—	—	—	—	11041	12734	12734	11041	14870	14870	11041	14870	14870
	OHL Input Shaft	—	—	—	—	—	—	—	—	—	(A)	713	742	(A)	839	873	(A)	958	997
	OHL Output Shaft (B)	—	—	—	—	—	—	—	—	—	2954	4471	4856	2954	4471	4856	2954	4471	4856
41.19	Output RPM	—	—	—	—	—	—	—	—	—	84	42	28	84	42	28	84	42	28
	Input HP (Max)	—	—	—	—	—	—	—	—	—	15.47	10.02	6.64	15.47	10.02	6.64	15.47	10.02	6.64
	Output Torque, In-Lb	—	—	—	—	—	—	—	—	—	11639	14870	14870	11639	14870	14870	11639	14870	14870
	OHL Input Shaft	—	—	—	—	—	—	—	—	—	(A)	713	742	(A)	839	873	(A)	958	997
	OHL Output Shaft (B)	—	—	—	—	—	—	—	—	—	3437	4471	4856	3437	4471	4856	3437	4471	4856
49.42	Output RPM	—	—	—	70	35	23	70	35	23	70	35	23	70	35	23	70	35	23
	Input HP (Max)	—	—	—	4.85	2.46	1.63	9.86	5.00	3.32	13.52	8.35	5.54	13.52	8.35	5.54	13.52	8.35	5.54
	Output Torque, In-Lb	—	—	—	4374	4374	4374	8905	8905	8905	12204	14870	14870	12204	14870	14870	12204	14870	14870
	OHL Input Shaft	—	—	—	(A)	346	360	(A)	454	473	(A)	714	743	(A)	839	876	(A)	959	998
	OHL Output Shaft (B)	—	—	—	3437	4856	4856	3437	4856	4856	3437	4856	4856	3437	4856	4856	3437	4856	4856
57.93	Output RPM	—	—	—	60	30	20	60	30	20	60	30	20	60	30	20	60	30	20
	Input HP (Max)	—	—	—	4.85	2.46	1.63	9.86	5.00	3.32	12.04	7.13	4.72	12.04	7.13	4.72	12.04	7.13	4.72
	Output Torque, In-Lb	—	—	—	5128	5128	5128	10439	10439	10439	12746	14870	14870	12746	14870	14870	12746	14870	14870
	OHL Input Shaft	—	—	—	(A)	346	360	(A)	452	471	(A)	709	739	(A)	839	878	(A)	959	998
	OHL Output Shaft (B)	—	—	—	4471	4856	4856	4471	4856	4856	4471	4856	4856	4471	4856	4856	4471	4856	4856
69.05	Output RPM	—	—	—	50	25	17	50	25	17	50	25	17	50	25	17	50	25	17
	Input HP (Max)	—	—	—	4.84	2.46	1.63	9.86	5.00	3.32	10.62	5.98	3.96	10.62	5.98	3.96	10.62	5.98	3.96
	Output Torque, In-Lb	—	—	—	6111	6111	6111	12441	12441	12441	13396	14870	14870	13396	14870	14870	13396	14870	14870
	OHL Input Shaft	—	—	—	(A)	346	360	(A)	456	474	(A)	709	739	(A)	839	879	(A)	959	998
	OHL Output Shaft (B)	—	—	—	4471	4856	4856	4471	4856	4856	4471	4856	4856	4471	4856	4856	4471	4856	4856
74.88	Output RPM	46	23	15	46	23	15	46	23	15	46	23	15	46	23	15	—	—	—
	Input HP (Max)	3.98	2.02	1.34	4.85	2.46	1.63	9.86	5.00	3.32	10.03	5.51	3.66	10.03	5.51	3.65	—	—	—
	Output Torque, In-Lb	5444	5444	5444	6628	6628	6628	13493	13493	13493	13715	14870	14870	13715	14870	14870	—	—	—
	OHL Input Shaft	(A)	219	226	(A)	346	360	(A)	456	474	(A)	711	740	(A)	839	879	—	—	—
	OHL Output Shaft (B)	4471	4856	4856	4471	4856	4856	4471	4856	4856	4471	4856	4856	4471	4856	4856	—	—	—
83.58	Output RPM	41	21	14	41	21	14	41	21	14	41	21	14	41	21	14	—	—	—
	Input HP (Max)	3.98	2.02	1.34	4.85	2.46	1.63	9.28	4.94	3.27	9.28	4.94	3.27	9.28	4.94	3.27	—	—	—
	Output Torque, In-Lb	6077	6077	6077	7398	7398	7398	14166	14870	14870	14166	14870	14870	14166	14870	14870	—	—	—
	OHL Input Shaft	(A)	219	228	(A)	346	360	(A)	455	474	(A)	712	741	(A)	839	879	—	—	—
	OHL Output Shaft (B)	4471	4856	4856	4471	4856	4856	4471	4856	4856	4471	4856	4856	4471	4856	4856	—	—	—
90.53	Output RPM	38	19	13	38	19	13	38	19	13	38	19	13	—	—	—	—	—	—
	Input HP (Max)	3.98	2.02	1.34	4.85	2.46	1.63	8.77	4.56	3.02	8.77	4.56	3.02	—	—	—	—	—	—
	Output Torque, In-Lb	6582	6582	6582	8013	8013	8013	14505	14870	14870	14505	14870	14870	—	—	—	—	—	—
	OHL Input Shaft	(A)	218	227	(A)	346	360	(A)	456	474	(A)	713	742	—	—	—	—	—	—
	OHL Output Shaft (B)	4856	4856	4856	4856	4856	4856	4856	4856	4856	4856	4856	4856	—	—	—	—	—	—

(A) Contact Engineering
 (B) OHL is for standard solid shaft diameters. Reference page 146 for optional shaft diameters. OHL's are applied at one shaft diameter from the shaft shoulder.
 OHL is calculated for the maximum reducer rating. Larger OHL's may be applied under certain conditions and are subject to application engineering review.
 Blank areas (—) indicate configuration not available

In-Line Helical Reducer (ILH)

Size: 883

Service Factor 1.0 – Clamp Collar / 3 Pc Coupled / Separate TRIPLE REDUCTION

NEMA Motor Frame IEC Motor Frame Separate Group		56C 71D 71			— 80D 80			140TC 90D 90			180TC 100D 100			— 112D 112			210TC 132D 132		
Ratio	Output Rating Data	3450	1750	1160	3450	1750	1160	3450	1750	1160	3450	1750	1160	3450	1750	1160	3450	1750	1160
102.61	Output RPM	34	17	11	34	17	11	34	17	11	34	17	11	—	—	—	—	—	—
	Input HP (Max)	3.98	2.02	1.34	4.84	2.46	1.63	7.93	4.02	2.67	7.93	4.02	2.67	—	—	—	—	—	—
	Output Torque, In-Lb	7460	7460	7460	9082	9082	9082	14870	14870	14870	14870	14870	14870	—	—	—	—	—	—
	OHL Input Shaft	(A)	217	226	(A)	346	360	(A)	456	475	(A)	713	743	—	—	—	—	—	—
	OHL Output Shaft (B)	4856	4856	4856	4856	4856	4856	4856	4856	4856	4856	4856	4856	—	—	—	—	—	—
110.54	Output RPM	31	16	10	31	16	10	31	16	10	31	16	10	—	—	—	—	—	—
	Input HP (Max)	3.88	2.02	1.34	4.84	2.46	1.63	7.36	3.74	2.48	7.36	3.74	2.48	—	—	—	—	—	—
	Output Torque, In-Lb	7845	8036	8036	9783	9783	9783	14870	14870	14870	14870	14870	14870	—	—	—	—	—	—
	OHL Input Shaft	(A)	218	227	(A)	346	359	(A)	457	475	(A)	714	743	—	—	—	—	—	—
	OHL Output Shaft (B)	4856	4856	4856	4856	4856	4856	4856	4856	4856	4856	4856	4856	—	—	—	—	—	—
119.52	Output RPM	29	15	10	29	15	10	29	15	10	29	15	10	—	—	—	—	—	—
	Input HP (Max)	3.66	1.99	1.34	4.85	2.46	1.63	6.81	3.45	2.29	6.81	3.45	2.29	—	—	—	—	—	—
	Output Torque, In-Lb	7983	8551	8690	10579	10579	10579	14870	14870	14870	14870	14870	14870	—	—	—	—	—	—
	OHL Input Shaft	(A)	217	226	(A)	345	359	(A)	457	475	(A)	714	743	—	—	—	—	—	—
	OHL Output Shaft (B)	4856	4856	4856	4856	4856	4856	4856	4856	4856	4856	4856	4856	—	—	—	—	—	—
129.79	Output RPM	27	13	9	27	13	9	27	13	9	27	13	9	—	—	—	—	—	—
	Input HP (Max)	3.43	1.86	1.28	4.84	2.46	1.63	6.27	3.18	2.11	6.27	3.18	2.11	—	—	—	—	—	—
	Output Torque, In-Lb	8125	8702	9019	11487	11487	11487	14870	14870	14870	14870	14870	14870	—	—	—	—	—	—
	OHL Input Shaft	(A)	218	226	(A)	345	359	(A)	453	471	(A)	714	743	—	—	—	—	—	—
	OHL Output Shaft (B)	4856	4856	4856	4856	4856	4856	4856	4856	4856	4856	4856	4856	—	—	—	—	—	—
143.50	Output RPM	24	12	8	24	12	8	24	12	8	24	12	8	—	—	—	—	—	—
	Input HP (Max)	3.16	1.72	1.18	4.84	2.46	1.63	5.67	2.88	1.91	5.67	2.88	1.91	—	—	—	—	—	—
	Output Torque, In-Lb	8286	8876	9200	12701	12701	12701	14870	14870	14870	14870	14870	14870	—	—	—	—	—	—
	OHL Input Shaft	(A)	218	226	(A)	344	358	(A)	454	471	(A)	714	743	—	—	—	—	—	—
	OHL Output Shaft (B)	4856	4856	4856	4856	4856	4856	4856	4856	4856	4856	4856	4856	—	—	—	—	—	—
155.46	Output RPM	22	11	7	22	11	7	22	11	7	22	11	7	—	—	—	—	—	—
	Input HP (Max)	2.96	1.61	1.11	4.84	2.46	1.63	5.24	2.66	1.76	5.24	2.66	1.76	—	—	—	—	—	—
	Output Torque, In-Lb	8408	9007	9337	13759	13759	13759	14870	14870	14870	14870	14870	14870	—	—	—	—	—	—
	OHL Input Shaft	(A)	218	226	(A)	344	358	(A)	453	472	(A)	714	744	—	—	—	—	—	—
	OHL Output Shaft (B)	4856	4856	4856	4856	4856	4856	4856	4856	4856	4856	4856	4856	—	—	—	—	—	—
175.18	Output RPM	20	10	7	20	10	7	20	10	7	20	10	7	—	—	—	—	—	—
	Input HP (Max)	2.68	1.46	1.00	4.65	2.36	1.56	4.65	2.36	1.56	4.65	2.36	1.56	—	—	—	—	—	—
	Output Torque, In-Lb	8583	9190	9525	14870	14870	14870	14870	14870	14870	14870	14870	14870	—	—	—	—	—	—
	OHL Input Shaft	(A)	218	227	(A)	343	357	(A)	455	473	(A)	715	744	—	—	—	—	—	—
	OHL Output Shaft (B)	4856	4856	4856	4856	4856	4856	4856	4856	4856	4856	4856	4856	—	—	—	—	—	—
191.80	Output RPM	18	9	6	18	9	6	18	9	6	—	—	—	—	—	—	—	—	—
	Input HP (Max)	2.48	1.35	0.93	4.24	2.15	1.43	4.24	2.15	1.43	—	—	—	—	—	—	—	—	—
	Output Torque, In-Lb	8701	9320	9659	14870	14870	14870	14870	14870	14870	—	—	—	—	—	—	—	—	—
	OHL Input Shaft	(A)	218	227	(A)	344	358	(A)	455	474	—	—	—	—	—	—	—	—	—
	OHL Output Shaft (B)	4856	4856	4856	4856	4856	4856	4856	4856	4856	—	—	—	—	—	—	—	—	—

(A) Contact Engineering

(B) OHL is for standard solid shaft diameters. Reference page 146 for optional shaft diameters. OHL's are applied at one shaft diameter from the shaft shoulder.

OHL is calculated for the maximum reducer rating. Larger OHL's may be applied under certain conditions and are subject to application engineering review.

Blank areas (—) indicate configuration not available

In-Line Helical Reducer (ILH)

Size: 883

Service Factor 1.0 – Clamp Collar / 3 Pc Coupled / Separate TRIPLE REDUCTION

NEMA Motor Frame IEC Motor Frame Separate Group		56C 71D 71			— 80D 80			140TC 90D 90			180TC 100D 100			— 112D 112			210TC 132D 132		
Ratio	Output Rating Data	3450	1750	1160	3450	1750	1160	3450	1750	1160	3450	1750	1160	3450	1750	1160	3450	1750	1160
213.64	Output RPM	16	8	5	16	8	5	16	8	5	—	—	—	—	—	—	—	—	—
	Input HP (Max)	2.26	1.23	0.84	3.81	1.93	1.28	3.81	1.93	1.28	—	—	—	—	—	—	—	—	—
	Output Torque, In-Lb	8834	9461	9807	14870	14870	14870	14870	14870	14870	—	—	—	—	—	—	—	—	—
	OHL Input Shaft	(A)	219	227	(A)	345	359	(A)	456	474	—	—	—	—	—	—	—	—	—
	OHL Output Shaft (B)	4856	4856	4856	4856	4856	4856	4856	4856	4856	—	—	—	—	—	—	—	—	—
244.29	Output RPM	14	7	5	14	7	5	14	7	5	—	—	—	—	—	—	—	—	—
	Input HP (Max)	2.01	1.09	0.75	3.33	1.69	1.12	3.33	1.69	1.12	—	—	—	—	—	—	—	—	—
	Output Torque, In-Lb	8985	9623	9974	14870	14870	14870	14870	14870	14870	—	—	—	—	—	—	—	—	—
	OHL Input Shaft	(A)	219	227	(A)	345	359	(A)	456	475	—	—	—	—	—	—	—	—	—
	OHL Output Shaft (B)	4856	4856	4856	4856	4856	4856	4856	4856	4856	—	—	—	—	—	—	—	—	—
270.90	Output RPM	13	6	4	13	6	4	13	6	4	—	—	—	—	—	—	—	—	—
	Input HP (Max)	1.84	1.00	0.69	3.00	1.52	1.01	3.00	1.52	1.01	—	—	—	—	—	—	—	—	—
	Output Torque, In-Lb	9091	9735	10091	14870	14870	14870	14870	14870	14870	—	—	—	—	—	—	—	—	—
	OHL Input Shaft	(A)	219	228	(A)	345	359	(A)	456	475	—	—	—	—	—	—	—	—	—
	OHL Output Shaft (B)	4856	4856	4856	4856	4856	4856	4856	4856	4856	—	—	—	—	—	—	—	—	—
300.41	Output RPM	11	6	4	11	6	4	11	6	4	—	—	—	—	—	—	—	—	—
	Input HP (Max)	1.67	0.91	0.62	2.17	1.37	0.81	2.17	1.37	0.81	—	—	—	—	—	—	—	—	—
	Output Torque, In-Lb	9186	9840	10199	11903	14870	13169	11903	14870	13169	—	—	—	—	—	—	—	—	—
	OHL Input Shaft	(A)	219	228	(A)	346	360	(A)	457	476	—	—	—	—	—	—	—	—	—
	OHL Output Shaft (B)	4856	4856	4856	4856	4856	4856	4856	4856	4856	—	—	—	—	—	—	—	—	—

(A) Contact Engineering

(B) OHL is for standard solid shaft diameters. Reference page 146 for optional shaft diameters. OHL's are applied at one shaft diameter from the shaft shoulder. OHL is calculated for the maximum reducer rating. Larger OHL's may be applied under certain conditions and are subject to application engineering review. Blank areas (—) indicate configuration not available

H50
Reducer

900 Series
Single Reduction

900 Series
Double Reduction

Accessories

Ratio Multiplier

In-Line Helical (ILH)

Universal Series
Single Reduction

Universal Series
Double Reduction

Engineering

In-Line Helical Reducer (ILH)
HB Clamp Collar/Coupled Input - Single Reduction

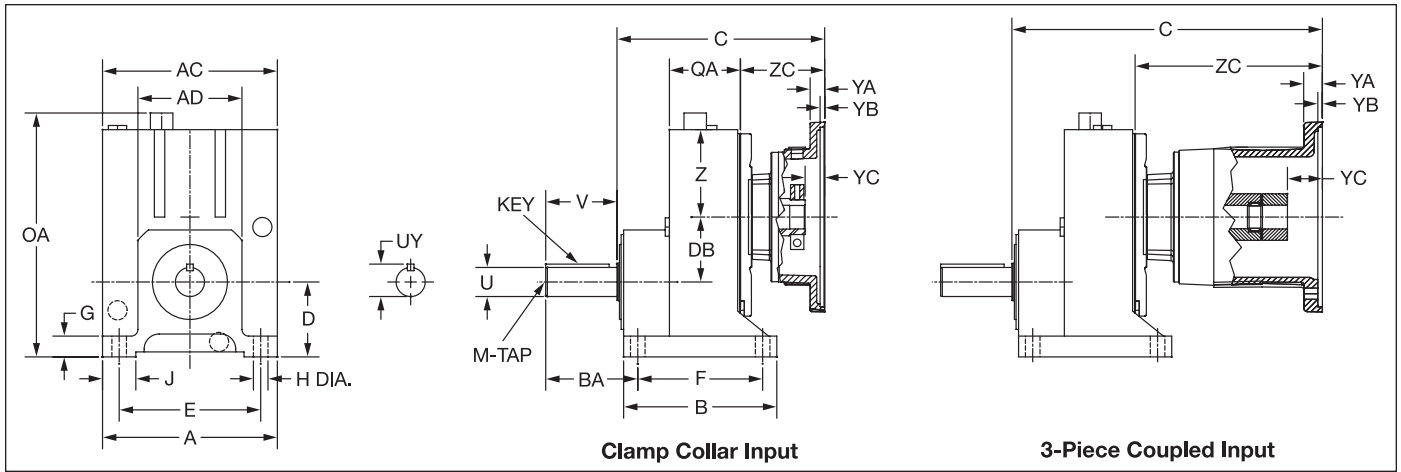

Standard Output Shaft

Size	U	Tolerance	UY	V	Key	M-Tap
38	0.875	+0.000 -0.001	0.95	2.24	3/16 x 3/16 x 1.50	5/16-18 UNC
48	1.125	+0.000 -0.001	1.23	2.74	1/4 x 1/4 x 2.35	3/8-16 UNC
68	1.375	+0.000 -0.001	1.51	3.37	5/16 x 5/16 x 3.00	3/8-16 UNC
88	1.625	+0.000 -0.001	1.79	3.15	3/8 x 3/8 x 2.75	5/8-11 UNC

Gearcase

Size	A	AC	AD	B	BA	D	E	F	G	øH	J	OA	DB	Z	QA
38	6.1	5.1	3.6	5.4	2.9	2.2	4.92	4.33	0.7	0.43	1.4	7.5	1.93	2.6	2.34
48	6.7	6.7	3.8	6.0	3.8	3.2	5.31	4.72	0.8	0.53	1.5	9.9	2.54	3.4	2.60
68	8.3	8.3	5.0	7.3	4.4	3.6	6.69	5.91	1.0	0.69	1.6	11.6	3.07	4.2	3.35
88	10.3	10.3	6.3	8.1	4.4	4.0	8.46	6.30	1.2	0.69	2.4	13.8	3.90	5.2	3.86

NEMA Motor Adapter – Clamp Collar

NEMA Frame	38		48		68		88		YA	YB	YC
	C	ZC	C	ZC	C	ZC	C	ZC			
56C	7.8	3.5	7.6	3.3	8.9	3.1	—	—	0.47	0.20	0.67
140TC	8.5	4.2	8.3	4.0	9.6	3.7	9.5	3.1	0.47	0.20	0.67
180TC	8.8	4.5	9.9	5.5	11.0	5.2	10.9	4.5	0.69	0.22	0.93
210TC	—	—	—	—	12.9	7.1	12.8	6.4	0.69	0.22	0.89
250TC	—	—	—	—	—	—	12.7	6.3	0.94	0.20	1.13

NEMA Motor Adapter – 3 Piece Coupled

NEMA Frame	38		48		68		88		YA	YB	YC
	C	ZC	C	ZC	C	ZC	C	ZC			
56C	11.0	6.6	10.8	6.4	12.0	6.2	—	—	0.55	0.20	1.08
140TC	12.4	8.1	12.2	7.8	13.4	7.6	13.4	7.0	0.55	0.20	1.10
180TC	—	—	13.4	9.1	14.6	8.8	14.5	8.1	0.73	0.22	1.65
210TC	—	—	—	—	16.8	11.0	16.6	10.2	0.87	0.22	2.01
250TC	—	—	—	—	—	—	18.5	12.2	0.94	0.20	2.17

H50 Reducer
900 Series Single Reduction
900 Series Double Reduction
Accessories
Ratio Multipliers
In-Line Helical (ILH)
Universal Series Single Reduction
Universal Series Double Reduction
Engineering

In-Line Helical Reducer (ILH)

HB Clamp Collar Input - Double and Triple Reduction

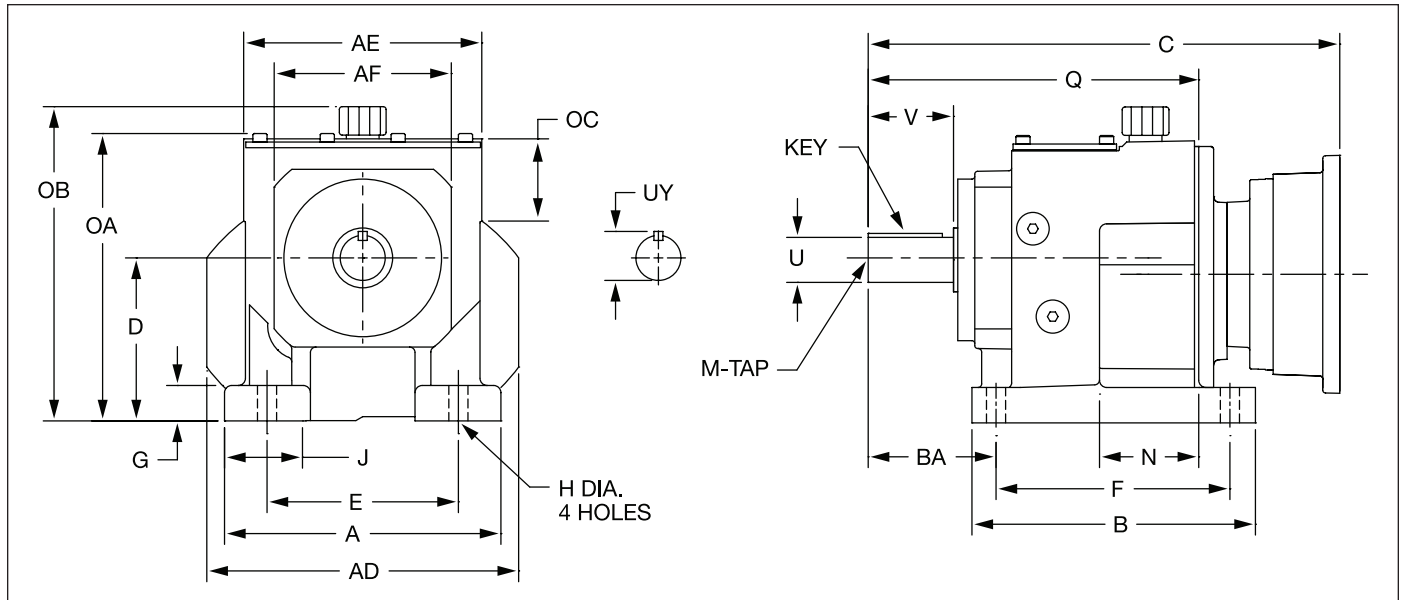

Size	Frame Size	A	B	C		D	E	F	G	OH	J	N	Q	AD	AE	AF	BA
				Double	Triple												
HB38	56C	5.77	6.30	8.98	9.57	3.54	4.33	5.12	0.79	0.39	1.33	2.33	7.48	6.42	5.07	3.77	2.95
	140TC			9.65	10.24												
	180TC			9.98	—												
HB48	56C	7.68	7.87	10.06	10.73	4.53	5.32	6.50	0.98	0.53	2.17	2.76	6.81	8.66	6.61	4.92	3.54
	140TC			10.73	11.40												
	180TC			11.07	11.74												
HB68	56C	9.25	9.65	11.24	11.97	5.51	6.69	8.07	1.18	0.69	2.36	3.27	11.38	10.35	8.14	6.32	4.53
	140TC			11.91	12.64												
	180TC			12.26	12.99												
	210TC			15.33	—												
HB88	56C	11.42	12.21	—	13.88	7.09	8.47	10.24	1.77	0.69	2.95	4.26	14.41	13.07	10.24	7.87	5.52
	140TC			13.56	14.55												
	180TC			13.82	14.90												
	210TC			16.85	17.95												
	250TC			16.74	—												

Standard Output Shaft

Size	U	Tolerance	UY	V	Key	M-Tap x Depth
38	1.000	+0.0000/ -0.0005	1.11	1.97	1/4 x 1/4 x 1-5/8	3/8-16 UNC x 0.87
48	1.250	+0.0000/ -0.0005	1.36	2.36	1/4 x 1/4 x 2	3/8-16 UNC x 0.87
68	1.625	+0.0000/ -0.0010	1.79	3.15	3/8 x 3/8 x 2-5/8	5/8-11 UNC x 1.42
88	2.125	+0.0000/ -0.0010	2.35	3.94	1/2 x 1/2 x 3-1/4	3/4-10 UNC x 1.65

Optional Output Shaft

Size	U	Tolerance	UY	V	Key	M-Tap x Depth
38	1.250	+0.0000/ -0.0005	1.36	2.36	1/4 x 1/4 x 2	3/8-16 UNC x 0.87
48	1.625	+0.0000/ -0.0005	1.79	3.15	3/8 x 3/8 x 2-5/8	5/8-11 UNC x 1.42
68	2.125	+0.0000/ -0.0010	2.35	3.94	1/2 x 1/2 x 3-1/4	3/4-10 UNC x 1.65
88	2.375	+0.0000/ -0.0010	2.65	4.72	5/8 x 5/8 x 3-15/16	3/4-10 UNC x 1.65

In-Line Helical Reducer (ILH) HB Coupled Input - Double and Triple Reduction

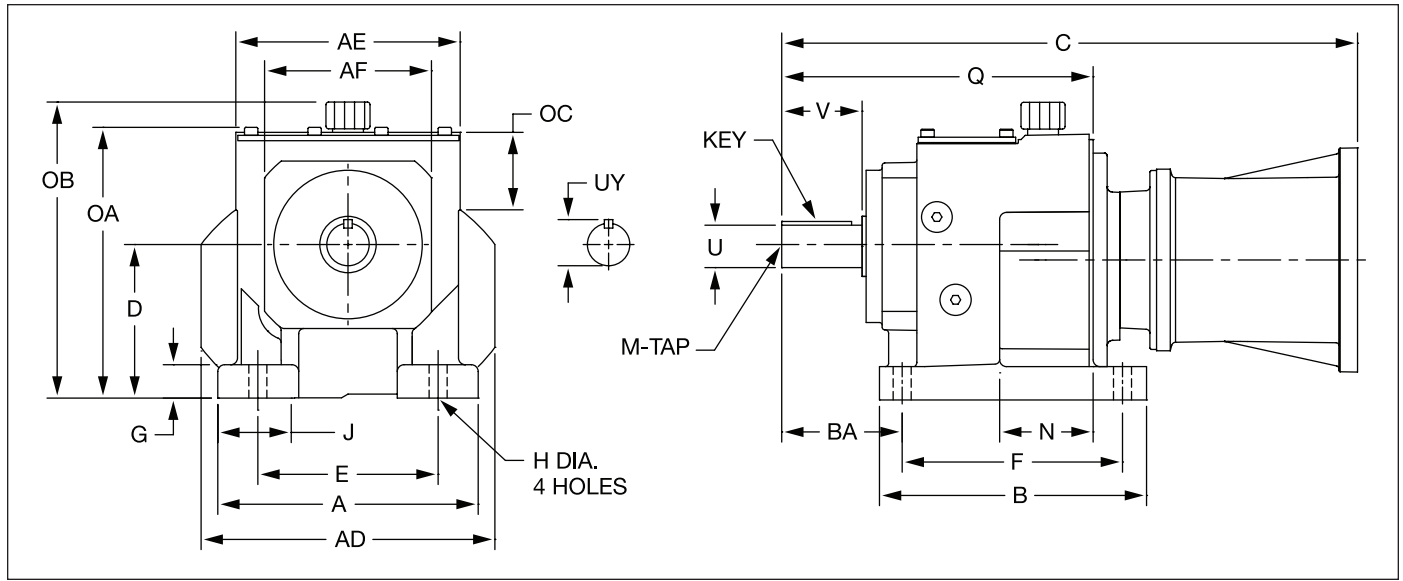

Size	Frame Size	A	B	C		D	E	F	G	OH	J	N	Q	AD	AE	AF	BA
				Double	Triple												
HB38	56C	5.77	6.30	8.98	9.57	3.54	4.33	5.12	0.79	0.39	1.33	2.33	7.48	6.42	5.07	3.77	2.95
	140TC			9.65	10.24												
	180TC			9.98	—												
HB48	56C	7.68	7.87	10.06	10.73	4.53	5.32	6.50	0.98	0.53	2.17	2.76	6.81	8.66	6.61	4.92	3.54
	140TC			10.73	11.40												
	180TC			11.07	11.74												
HB68	56C	9.25	9.65	11.24	11.97	5.51	6.69	8.07	1.18	0.69	2.36	3.27	11.38	10.35	8.14	6.32	4.53
	140TC			11.91	12.64												
	180TC			12.26	12.99												
	210TC			15.33	—												
HB88	56C	11.42	12.21	—	13.88	7.09	8.47	10.24	1.77	0.69	2.95	4.26	14.41	13.07	10.24	7.87	5.52
	140TC			13.56	14.55												
	180TC			13.82	14.90												
	210TC			16.85	17.95												
	250TC			16.74	—												

Standard Output Shaft

Size	U	Tolerance	UY	V	Key	M-Tap x Depth
38	1.000	+0.0000/-0.0005	1.11	1.97	1/4 x 1/4 x 1-5/8	3/8-16 UNC x 0.87
48	1.250	+0.0000/-0.0005	1.36	2.36	1/4 x 1/4 x 2	3/8-16 UNC x 0.87
68	1.625	+0.0000/-0.0010	1.79	3.15	3/8 x 3/8 x 2-5/8	5/8-11 UNC x 1.42
88	2.125	+0.0000/-0.0010	2.35	3.94	1/2 x 1/2 x 3-1/4	3/4-10 UNC x 1.65

Optional Output Shaft

Size	U	Tolerance	UY	V	Key	M-Tap x Depth
38	1.250	+0.0000/-0.0005	1.36	2.36	1/4 x 1/4 x 2	3/8-16 UNC x 0.87
48	1.625	+0.0000/-0.0005	1.79	3.15	3/8 x 3/8 x 2-5/8	5/8-11 UNC x 1.42
68	2.125	+0.0000/-0.0010	2.35	3.94	1/2 x 1/2 x 3-1/4	3/4-10 UNC x 1.65
88	2.375	+0.0000/-0.0010	2.65	4.72	5/8 x 5/8 x 3-15/16	3/4-10 UNC x 1.65

In-Line Helical Reducer (ILH) HF B14 Clamp Collar/Coupled Input - Single Reduction

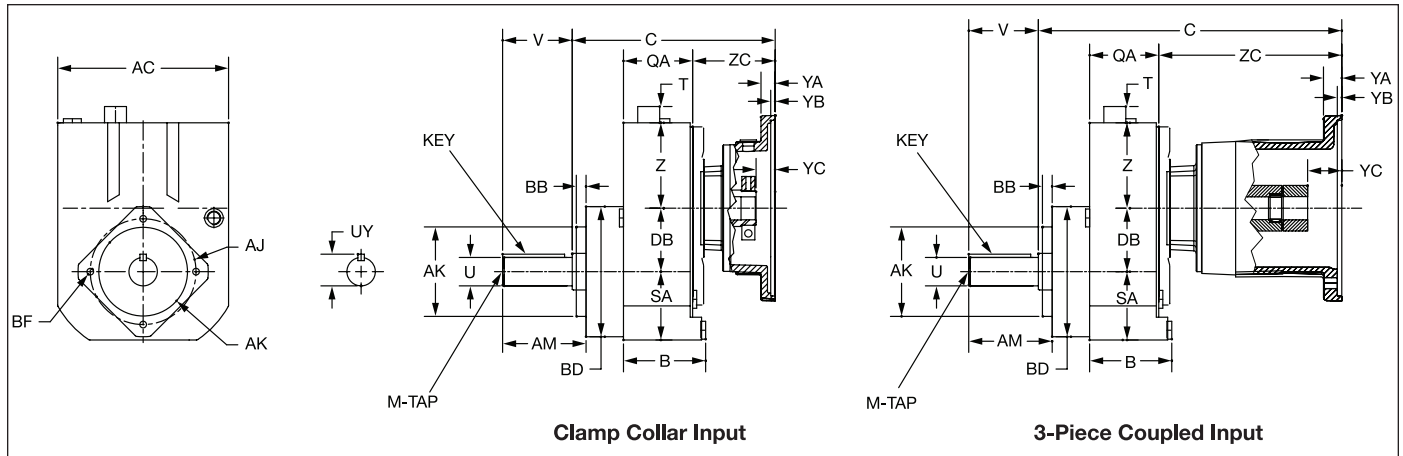

Standard Output Shaft

Size	U	Tolerance	UY	V	Key	M-Tap
38	0.875	+0.000 -0.001	0.95	2.24	3/16 x 3/16 x 1.50	5/16-18 UNC
48	1.125	+0.000 -0.001	1.23	2.74	1/4 x 1/4 x 2.35	3/8-16 UNC
68	1.375	+0.000 -0.001	1.51	3.37	5/16 x 5/16 x 3.00	3/8-16 UNC
88	1.625	+0.000 -0.001	1.79	3.15	3/8 x 3/8 x 2.75	5/8-11 UNC

Gearcase / Flange

Size	Output Flange	AJ	AK	tol.	BB	AM	BD	BF	AC	B	QA	SA	DB	Z	T
38	B14 120MM	3.937	3.1496	+0.0005 -0.0003	0.35	2.75	4.8	M8 x 1.25	5.1	2.3	2.4	2.4	1.93	2.6	0.9
48	B14 120MM	3.937	3.1496	+0.0005 -0.0003	0.35	3.25	4.8	M8 x 1.25	6.7	3.2	2.6	3.0	2.54	3.4	0.9
68	B14 160MM	5.118	4.3307	+0.0005 -0.0004	0.45	4.04	6.3	M10 x 1.5	8.3	4.0	3.4	3.4	3.07	4.2	0.9
88	B14 190MM	6.496	5.1181	+0.0006 -0.0004	0.41	3.86	7.5	M12 x 1.75	10.3	4.4	3.9	4.2	3.90	5.2	0.9

NEMA Motor Adapter – Clamp Collar

NEMA Frame	38		48		68		88		YA	YB	YC
	C	ZC	C	ZC	C	ZC	C	ZC			
56C	7.3	3.5	7.1	3.3	8.2	3.1	-	-	0.47	0.20	0.67
140TC	8.0	4.2	7.8	4.0	8.9	3.7	8.8	3.1	0.47	0.20	0.67
180TC	8.3	4.5	9.4	5.5	10.4	5.2	10.2	4.5	0.69	0.22	0.93
210TC	—	—	—	—	12.3	7.1	12.0	6.4	0.69	0.22	0.89
250TC	—	—	—	—	—	—	12.0	6.3	0.94	0.20	1.13

NEMA Motor Adapter – 3 Piece Coupled

NEMA Frame	38		48		68		88		YA	YB	YC
	C	ZC	C	ZC	C	ZC	C	ZC			
56C	10.5	6.6	10.2	6.4	11.3	6.2	-	-	0.55	0.20	1.08
140TC	11.9	8.1	11.7	7.8	12.8	7.6	12.7	7.0	0.55	0.20	1.10
180TC	—	—	12.9	9.1	14.0	8.8	13.7	8.1	0.73	0.22	1.65
210TC	—	—	—	—	16.1	11.0	15.9	10.2	0.87	0.22	2.01
250TC	—	—	—	—	—	—	17.8	12.2	0.94	0.20	2.17

In-Line Helical Reducer (ILH) HF B14 Clamp Collar Input - Double and Triple Reduction

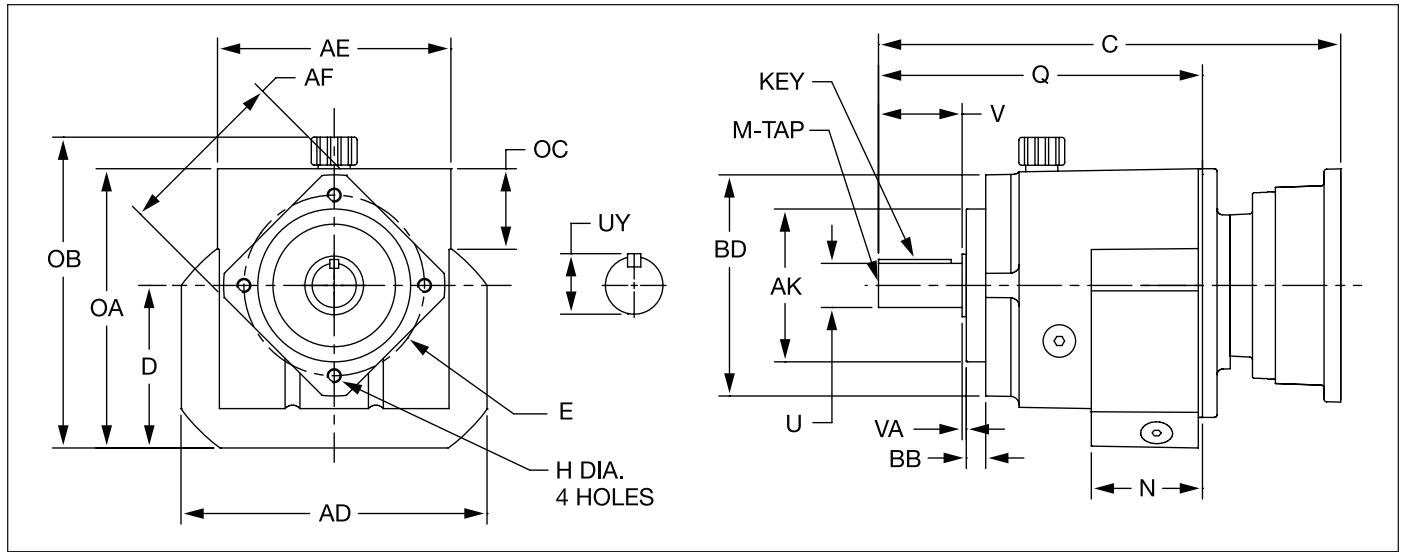

Size	Frame Size	C Double	C Triple	OB	OA	D	AD	OH	OE	OC	AE	AF	BD	AK	VA	BB	Q
HF38	56C	10.95	11.54	—	6.29	3.62	6.45	M8 x 0.43 Deep	3.94	1.83	5.07	3.96	4.72	3.15	0.12	0.39	7.48
	140TC	11.62	12.21														
	180TC	11.95	—														
HF48	56C	12.42	13.09	8.86	8.11	4.61	8.66	M10 x 0.63 Deep	5.12	2.31	6.61	4.91	6.30	4.33	0.12	0.59	9.17
	140TC	13.09	13.76														
	180TC	13.43	14.10														
HF68	56C	14.39	15.12	10.68	9.93	—	10.39	M12 x 0.67 Deep	6.50	2.97	8.14	6.10	7.48	5.12	—	0.55	11.38
	140TC	15.06	15.79														
	180TC	15.41	16.14														
	210TC	18.48	—														
HF88	56C	—	17.82	13.22	12.47	7.17	13.07	M16 x 0.87 Deep	8.47	3.62	10.23	7.73	9.65	7.09	—	0.71	14.41
	140TC	17.50	18.49														
	180TC	17.76	18.84														
	210TC	20.79	21.89														
	250TC	20.68	—														

Standard Output Shaft

Size	U	Tolerance	UY	V	Key	M-Tap x Depth
38	1.000	+0.0000/-0.0005	1.11	1.97	1/4 x 1/4 x 1-5/8	3/8-16 UNC x 0.87
48	1.250	+0.0000/-0.0005	1.36	2.36	1/4 x 1/4 x 2	3/8-16 UNC x 0.87
68	1.625	+0.0000/-0.0010	1.79	3.15	3/8 x 3/8 x 2-5/8	5/8-11 UNC x 1.42
88	2.125	+0.0000/-0.0010	2.35	3.94	1/2 x 1/2 x 3-1/4	3/4-10 UNC x 1.65

Optional Output Shaft

Size	U	Tolerance	UY	V	Key	M-Tap x Depth
38	1.250	+0.0000/-0.0005	1.36	2.36	1/4 x 1/4 x 2	3/8-16 UNC x 0.87
48	1.625	+0.0000/-0.0005	1.79	3.15	3/8 x 3/8 x 2-5/8	5/8-11 UNC x 1.42
68	2.125	+0.0000/-0.0010	2.35	3.94	1/2 x 1/2 x 3-1/4	3/4-10 UNC x 1.65
88	2.375	+0.0000/-0.0010	2.65	4.72	5/8 x 5/8 x 3-15/16	3/4-10 UNC x 1.65

In-Line Helical Reducer (ILH)

HF B14 Coupled Input - Double and Triple Reduction

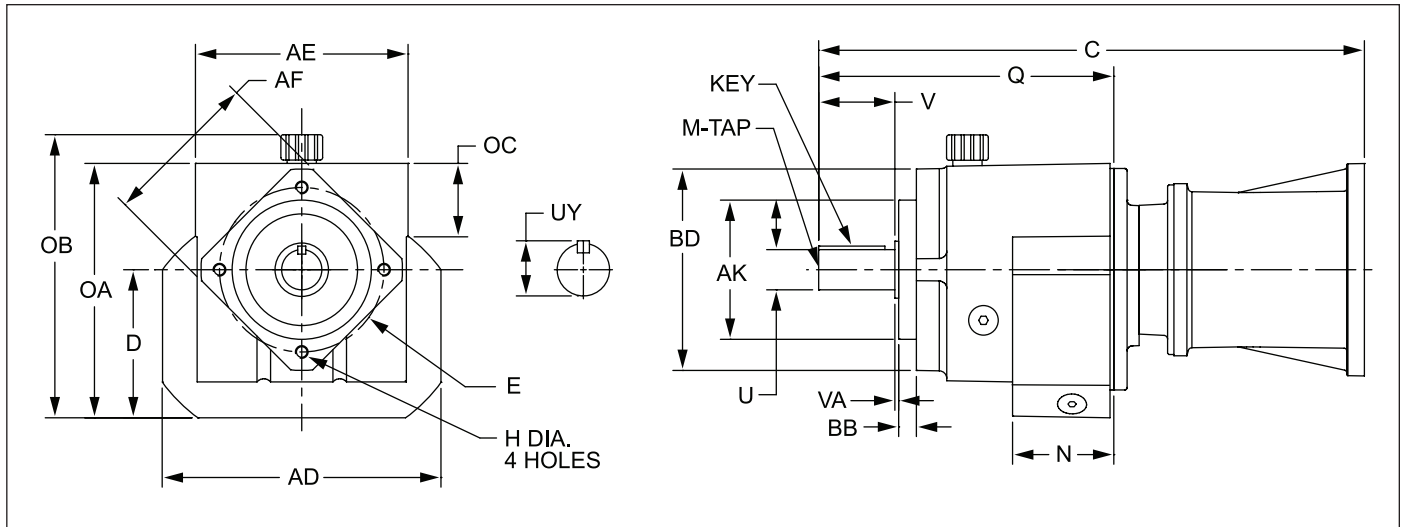

Size	Frame Size	C Double	C Triple	OB	OA	D	AD	OH	OE	OC	AE	AF	BD	AK	VA	BB	Q
HF38	56C	14.08	14.67	-	6.29	3.62	6.45	M8 x 0.43 Deep	3.94	1.83	5.07	3.96	4.72	3.15	0.12	0.39	7.48
	140TC	15.49	16.08														
	180TC	16.77	—														
HF48	56C	15.55	16.22	8.86	8.11	4.61	8.66	M10 x 0.63 Deep	5.12	2.31	6.61	4.91	6.30	4.33	0.12	0.59	9.17
	140TC	16.97	17.64														
	180TC	18.25	18.92														
HF68	56C	17.52	18.25	10.68	9.93	—	10.39	M12 x 0.67 Deep	6.50	2.97	8.14	6.10	7.48	5.12	—	0.55	11.38
	140TC	18.94	19.67														
	180TC	20.22	20.95														
	210TC	22.28	—														
HF88	56C	—	20.95	13.22	12.47	7.17	13.07	M16 x 0.87 Deep	8.47	3.62	10.23	7.73	9.65	7.09	—	0.71	14.41
	140TC	21.38	22.37														
	180TC	22.56	23.64														
	210TC	24.59	25.69														
	250TC	26.54	—														

Standard Output Shaft

Size	U	Tolerance	UY	V	Key	M-Tap x Depth
38	1.000	+0.0000/ -0.0005	1.11	1.97	1/4 x 1/4 x 1-5/8	3/8-16 UNC x 0.87
48	1.250	+0.0000/ -0.0005	1.36	2.36	1/4 x 1/4 x 2	3/8-16 UNC x 0.87
68	1.625	+0.0000/ -0.0010	1.79	3.15	3/8 x 3/8 x 2-5/8	5/8-11 UNC x 1.42
88	2.125	+0.0000/ -0.0010	2.35	3.94	1/2 x 1/2 x 3-1/4	3/4-10 UNC x 1.65

Optional Output Shaft

Size	U	Tolerance	UY	V	Key	M-Tap x Depth
38	1.250	+0.0000/ -0.0005	1.36	2.36	1/4 x 1/4 x 2	3/8-16 UNC x 0.87
48	1.625	+0.0000/ -0.0005	1.79	3.15	3/8 x 3/8 x 2-5/8	5/8-11 UNC x 1.42
68	2.125	+0.0000/ -0.0010	2.35	3.94	1/2 x 1/2 x 3-1/4	3/4-10 UNC x 1.65
88	2.375	+0.0000/ -0.0010	2.65	4.72	5/8 x 5/8 x 3-15/16	3/4-10 UNC x 1.65

In-Line Helical Reducer (ILH)

HF B5 Clamp Collar/Coupled Input - Single Reduction

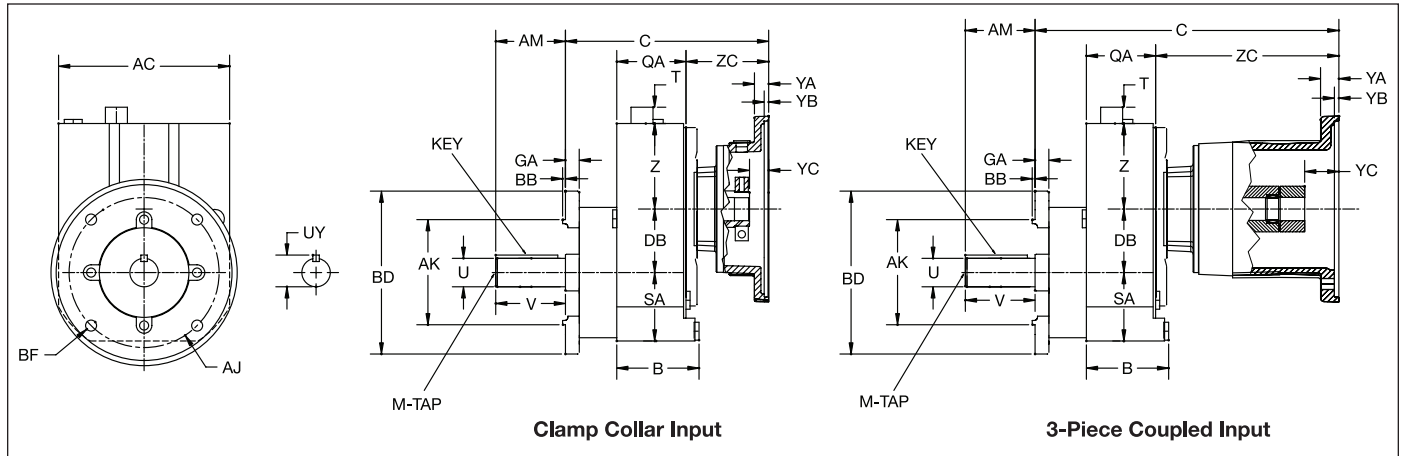

Standard Output Shaft

Size	U	Tolerance	UY	V	Key	M-Tap
38	0.875	+0.000 / -0.001	0.95	2.24	3/16 x 3/16 x 1.50	5/16-18 UNC
48	1.125	+0.000 / -0.001	1.23	2.74	1/4 x 1/4 x 2.35	3/8-16 UNC
68	1.375	+0.000 / -0.001	1.51	3.37	5/16 x 5/16 x 3.00	3/8-16 UNC
88	1.625	+0.000 / -0.001	1.79	3.15	3/8 x 3/8 x 2.75	5/8-11 UNC

Gearcase / Flange

Size	Output Flange	AJ	AK	Tolerance	BB	GA	AM	BD	BF	AC	B	QA	SA	DB	Z	T
38	NEMA 140TC	5.875	4.5000	+0.0000 -0.0030	0.15	0.7	2.12	6.5	0.41	5.1	2.3	2.4	2.4	1.93	2.6	0.9
	B5 160MM	5.118	4.3307	+0.0005 -0.0004	0.14	0.4	2.24	6.3	0.35	5.1	2.3	2.4	2.4	1.93	2.6	0.9
	B5 200MM	6.496	5.1181	+0.0006 -0.0004	0.14	0.5	2.24	7.9	0.43	5.1	2.3	2.4	2.4	1.93	2.6	0.9
48	NEMA 180TC	7.250	8.5000	+0.0000 -0.0030	0.26	0.4	2.88	9.0	0.53	6.7	3.2	2.6	3.0	2.54	3.4	0.9
	B5 160MM	5.118	4.3307	+0.0005 -0.0004	0.14	0.4	2.74	6.3	0.35	6.7	3.2	2.6	3.0	2.54	3.4	0.9
	B5 200MM	6.496	5.1181	+0.0006 -0.0004	0.14	0.5	2.74	7.9	0.43	6.7	3.2	2.6	3.0	2.54	3.4	0.9
68	NEMA 210TC	7.250	8.5000	+0.0000 -0.0030	0.26	0.7	3.38	9.0	0.53	8.3	4.0	3.4	3.4	3.07	4.2	0.9
	B5 200MM	6.496	5.1181	+0.0006 -0.0004	0.14	0.5	3.37	7.9	0.43	8.3	4.0	3.4	3.4	3.07	4.2	0.9
	B5 250MM	8.465	7.0866	+0.0006 -0.0004	0.16	0.6	3.37	9.9	0.53	8.3	4.0	3.4	3.4	3.07	4.2	0.9
88	B5 250MM	8.465	7.0866	+0.0006 -0.0004	0.16	0.6	3.15	9.9	0.53	10.3	4.4	3.9	4.2	3.90	5.2	0.9
	B5 300MM	10.433	9.0551	+0.0006 -0.0005	0.16	0.7	3.15	11.9	0.53	10.3	4.4	3.9	4.2	3.90	5.2	0.9

NEMA Motor Adapter – Clamp Collar

NEMA Frame	38		48		68		88		YA	YB	YC
	C	ZC	C	ZC	C	ZC	C	ZC			
56C	7.3	3.5	7.1	3.3	8.2	3.1	—	—	0.47	0.20	0.67
140TC	8.0	4.2	7.8	4.0	8.9	3.7	8.8	3.1	0.47	0.20	0.67
180TC	8.3	4.5	9.4	5.5	10.4	5.2	10.2	4.5	0.69	0.22	0.93
210TC	—	—	—	—	12.3	7.1	12.0	6.4	0.69	0.22	0.89
250TC	—	—	—	—	—	—	12.0	6.3	0.94	0.20	1.13

NEMA Motor Adapter – 3 Piece Coupled

NEMA Frame	38		48		68		88		YA	YB	YC
	C	ZC	C	ZC	C	ZC	C	ZC			
56C	10.5	6.6	10.2	6.4	11.3	6.2	—	—	0.55	0.20	1.08
140TC	11.9	8.1	11.7	7.8	12.8	7.6	12.7	7.0	0.55	0.20	1.10
180TC	—	—	12.9	9.1	14.0	8.8	13.7	8.1	0.73	0.22	1.65
210TC	—	—	—	—	16.1	11.0	15.9	10.2	0.87	0.22	2.01
250TC	—	—	—	—	—	—	17.8	12.2	0.94	0.20	2.17

In-Line Helical Reducer (ILH) HF B5 Clamp Collar Input - Double and Triple Reduction

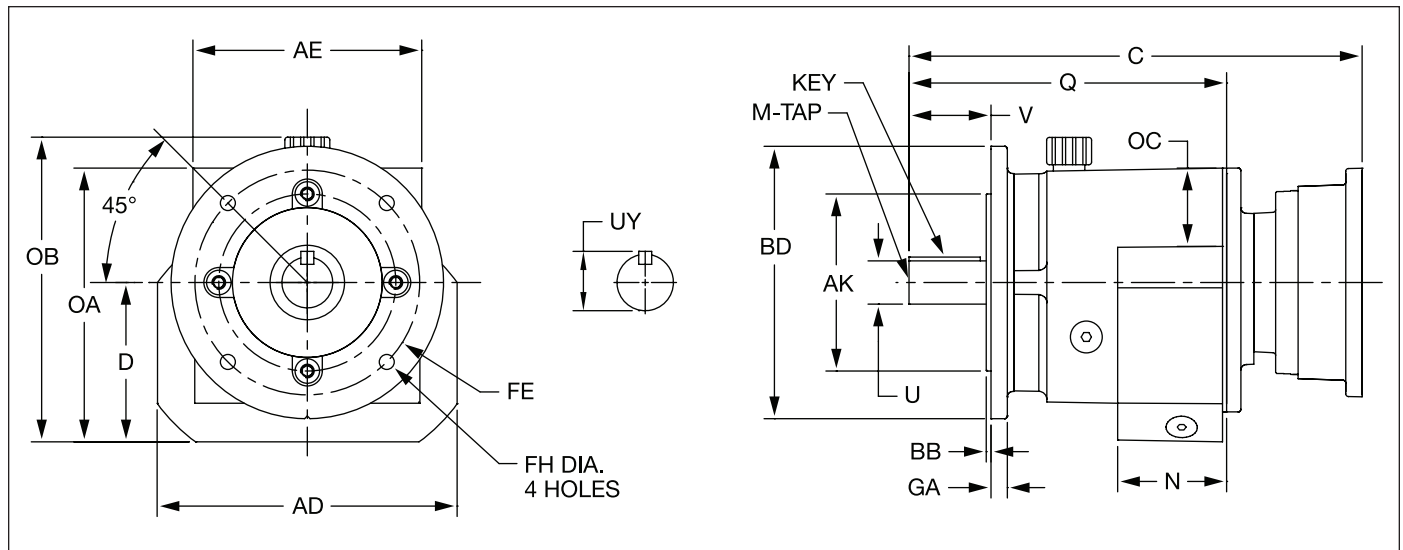

Size	Frame Size	C Double	C Triple	OB	OA	D	AD	FH	FE	OC	AE	BD	AK	BB	GA	Q
HF38	56C	10.95	11.54	—	6.29	3.62	6.45	0.35	5.12	1.83	5.07	6.30	4.33	0.14	0.39	7.48
	140TC	11.62	12.21													
	180TC	11.95	—													
HF48	56C	12.42	13.09	8.86	8.11	4.61	8.66	0.43	6.50	2.31	6.61	7.87	5.12	0.14	0.47	9.17
	140TC	13.09	13.76													
	180TC	13.43	14.10													
HF68	56C	14.39	15.12	10.68	9.93	—	10.39	0.53	8.47	2.97	8.14	9.84	7.09	0.16	0.59	11.38
	140TC	15.06	15.79													
	180TC	15.41	16.14													
	210TC	18.48	—													
HF88	56C	—	17.82	13.22	12.47	7.17	13.07	0.53	10.43	3.62	10.23	11.81	9.06	0.16	0.63	14.41
	140TC	13.56	18.49													
	180TC	13.82	18.84													
	210TC	16.85	21.89													
	250TC	16.74	—													

Standard Output Shaft

Size	U	Tolerance	UY	V	Key	M-Tap x Depth
38	1.000	+0.0000/ -0.0005	1.11	1.97	1/4 x 1/4 x 1-5/8	3/8-16 UNC x 0.87
48	1.250	+0.0000/ -0.0005	1.36	2.36	1/4 x 1/4 x 2	3/8-16 UNC x 0.87
68	1.625	+0.0000/ -0.0010	1.79	3.15	3/8 x 3/8 x 2-5/8	5/8-11 UNC x 1.42
88	2.125	+0.0000/ -0.0010	2.35	3.94	1/2 x 1/2 x 3-1/4	3/4-10 UNC x 1.65

Optional Output Shaft

Size	U	Tolerance	UY	V	Key	M-Tap x Depth
38	1.250	+0.0000/ -0.0005	1.36	2.36	1/4 x 1/4 x 2	3/8-16 UNC x 0.87
48	1.625	+0.0000/ -0.0005	1.79	3.15	3/8 x 3/8 x 2-5/8	5/8-11 UNC x 1.42
68	2.125	+0.0000/ -0.0010	2.35	3.94	1/2 x 1/2 x 3-1/4	3/4-10 UNC x 1.65
88	2.375	+0.0000/ -0.0010	2.65	4.72	5/8 x 5/8 x 3-15/16	3/4-10 UNC x 1.65

In-Line Helical Reducer (ILH) HF B5 Coupled Input - Double and Triple Reduction

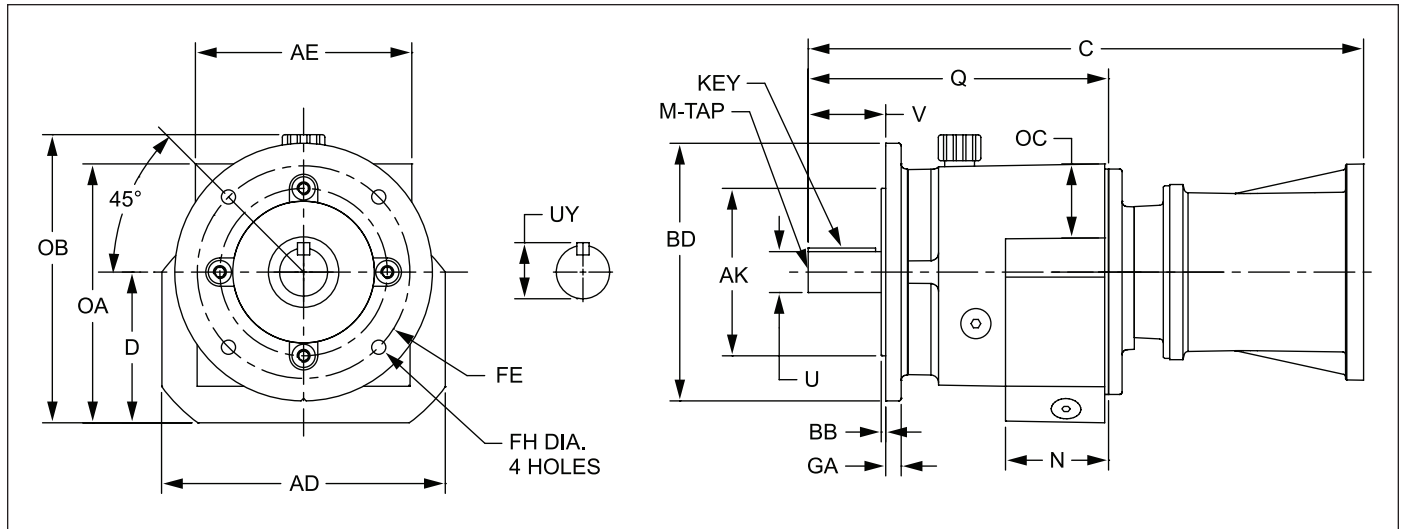

Size	Frame Size	C Double	C Triple	OB	OA	D	AD	FH	FE	OC	AE	BD	AK	BB	GA	Q
HF38	56C	14.08	14.67	—	6.29	3.62	6.45	0.35	5.12	1.83	5.07	6.30	4.33	0.14	0.39	7.48
	140TC	15.49	16.08													
	180TC	16.77	—													
HF48	56C	15.55	16.22	8.86	8.11	4.61	8.66	0.43	6.50	2.31	6.61	7.87	5.12	0.14	0.47	9.17
	140TC	16.97	17.64													
	180TC	18.25	18.92													
HF68	56C	17.52	18.25	10.68	9.93	—	10.39	0.53	8.47	2.97	8.14	9.84	7.09	0.16	0.59	11.38
	140TC	18.94	19.67													
	180TC	20.22	20.95													
	210TC	22.28	—													
HF88	56C	—	20.95	13.22	12.47	7.17	13.07	0.53	10.43	3.62	10.23	11.81	9.06	0.16	0.63	14.41
	140TC	21.38	22.37													
	180TC	22.56	23.64													
	210TC	24.59	25.69													
	250TC	26.54	—													

Standard Output Shaft

Size	U	Tolerance	UY	V	Key	M-Tap x Depth
38	1.000	+0.0000/-0.0005	1.11	1.97	1/4 x 1/4 x 1-5/8	3/8-16 UNC x 0.87
48	1.250	+0.0000/-0.0005	1.36	2.36	1/4 x 1/4 x 2	3/8-16 UNC x 0.87
68	1.625	+0.0000/-0.0010	1.79	3.15	3/8 x 3/8 x 2-5/8	5/8-11 UNC x 1.42
88	2.125	+0.0000/-0.0010	2.35	3.94	1/2 x 1/2 x 3-1/4	3/4-10 UNC x 1.65

Optional Output Shaft

Size	U	Tolerance	UY	V	Key	M-Tap x Depth
38	1.250	+0.0000/-0.0005	1.36	2.36	1/4 x 1/4 x 2	3/8-16 UNC x 0.87
48	1.625	+0.0000/-0.0005	1.79	3.15	3/8 x 3/8 x 2-5/8	5/8-11 UNC x 1.42
68	2.125	+0.0000/-0.0010	2.35	3.94	1/2 x 1/2 x 3-1/4	3/4-10 UNC x 1.65
88	2.375	+0.0000/-0.0010	2.65	4.72	5/8 x 5/8 x 3-15/16	3/4-10 UNC x 1.65

In-Line Helical Reducer (ILH) HB Separate Input - Double and Triple Reduction

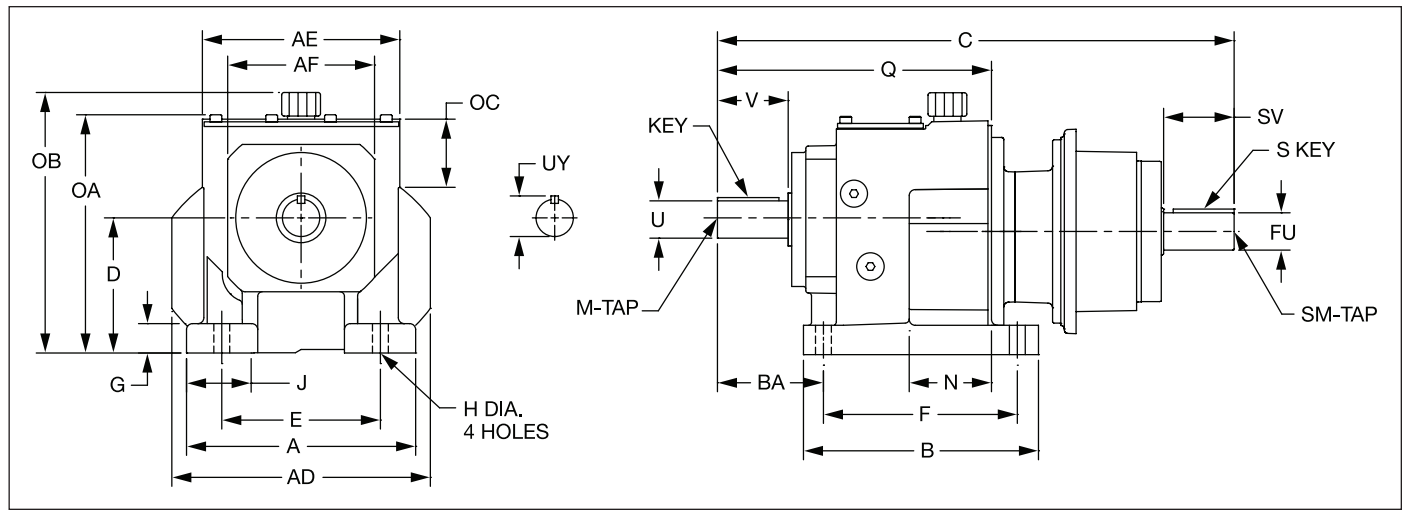

Size	Frame Size	A	B	C		D	E	F	G	OH	J	N	Q	AD	AE	AF	BA	Input Shaft Dimensions			
				Double	Triple													FU	SV	S KEY	SM-TAP
HB38	71	5.77	6.30	13.43	14.02	3.54	4.33	5.12	0.79	0.39	1.33	2.33	7.48	6.42	5.07	3.77	2.95	0.625	1.57	3/16 x 3/16 x 1-5/16	8-32 UNC x 0.49
	80			14.80	15.40													0.750	1.57	3/16 x 3/16 x 1-5/16	1/4-20 UNC x 0.63
	90			15.20	15.79													0.875	1.97	3/16 x 3/16 x 1-5/8	5/16-18 UNC x 0.75
	100			15.83	—													1.125	2.36	1/4 x 1/4 x 2	3/8-16 UNC x 0.87
HB48	71	7.68	7.87	14.84	15.59	4.53	5.32	6.50	0.98	0.53	2.17	2.76	6.81	8.66	6.61	4.92	3.54	0.625	1.57	3/16 x 3/16 x 1-5/16	8-32 UNC x 0.49
	80			16.30	16.97													0.750	1.57	3/16 x 3/16 x 1-5/16	1/4-20 UNC x 0.63
	90			16.69	17.34													0.875	1.97	3/16 x 3/16 x 1-5/8	5/16-18 UNC x 0.75
	100			17.32	18.19													1.125	2.36	1/4 x 1/4 x 2	3/8-16 UNC x 0.87
	112			17.36	—													1.250	2.36	5/16 x 5/16 x 2-1/16	3/8-16 UNC x 0.87
HB68	71	9.25	9.65	16.89	17.60	5.51	6.69	8.07	1.18	0.69	2.36	3.27	11.38	10.35	8.14	6.32	4.53	0.625	1.57	3/16 x 3/16 x 1-5/16	8-32 UNC x 0.49
	80			18.27	18.98													0.750	1.57	3/16 x 3/16 x 1-5/16	1/4-20 UNC x 0.63
	90			18.66	19.37													0.875	1.97	3/16 x 3/16 x 1-5/8	5/16-18 UNC x 0.75
	100			19.29	20.00													1.125	2.36	1/4 x 1/4 x 2	3/8-16 UNC x 0.87
	112			19.25	—													1.250	2.36	5/16 x 5/16 x 2-1/16	3/8-16 UNC x 0.87
	132			22.56	—													1.375	2.36	5/16 x 5/16 x 2-1/16	3/8-16 UNC x 0.87
HB88	71	11.42	12.21	—	20.32	7.09	8.47	10.24	1.77	0.69	2.95	4.26	14.41	13.07	10.24	7.87	5.52	0.625	1.57	3/16 x 3/16 x 1-5/16	8-32 UNC x 0.49
	80			—	21.70													0.750	1.57	3/16 x 3/16 x 1-5/16	1/4-20 UNC x 0.63
	90			21.11	22.09													0.875	1.97	3/16 x 3/16 x 1-5/8	5/16-18 UNC x 0.75
	100			21.62	22.72													1.125	2.36	1/4 x 1/4 x 2	3/8-16 UNC x 0.87
	112			21.54	22.68													1.250	2.36	5/16 x 5/16 x 2-1/16	3/8-16 UNC x 0.87
	132			24.88	25.99													1.375	3.15	5/16 x 5/16 x 2-3/4	3/8-16 UNC x 1.10
	160			26.58	—													1.625	4.33	3/8 x 3/8 x 3-1/2	5/8-11 UNC x 1.42

Standard Output Shaft

Size	U	Tolerance	UY	V	Key	M-Tap x Depth
38	1.000	+0.0000/ -0.0005	1.11	1.97	1/4 x 1/4 x 1-5/8	3/8-16 UNC x 0.87
48	1.250	+0.0000/ -0.0005	1.36	2.36	1/4 x 1/4 x 2	3/8-16 UNC x 0.87
68	1.625	+0.0000/ -0.0010	1.79	3.15	3/8 x 3/8 x 2-5/8	5/8-11 UNC x 1.42
88	2.125	+0.0000/ -0.0010	2.35	3.94	1/2 x 1/2 x 3-1/4	3/4-10 UNC x 1.65

Optional Output Shaft

Size	U	Tolerance	UY	V	Key	M-Tap x Depth
38	1.250	+0.0000/ -0.0005	1.36	2.36	1/4 x 1/4 x 2	3/8-16 UNC x 0.87
48	1.625	+0.0000/ -0.0005	1.79	3.15	3/8 x 3/8 x 2-5/8	5/8-11 UNC x 1.42
68	2.125	+0.0000/ -0.0010	2.35	3.94	1/2 x 1/2 x 3-1/4	3/4-10 UNC x 1.65
88	2.375	+0.0000/ -0.0010	2.65	4.72	5/8 x 5/8 x 3-15/16	3/4-10 UNC x 1.65

In-Line Helical Reducer (ILH)
HF B14 Separate Input - Double and Triple Reduction

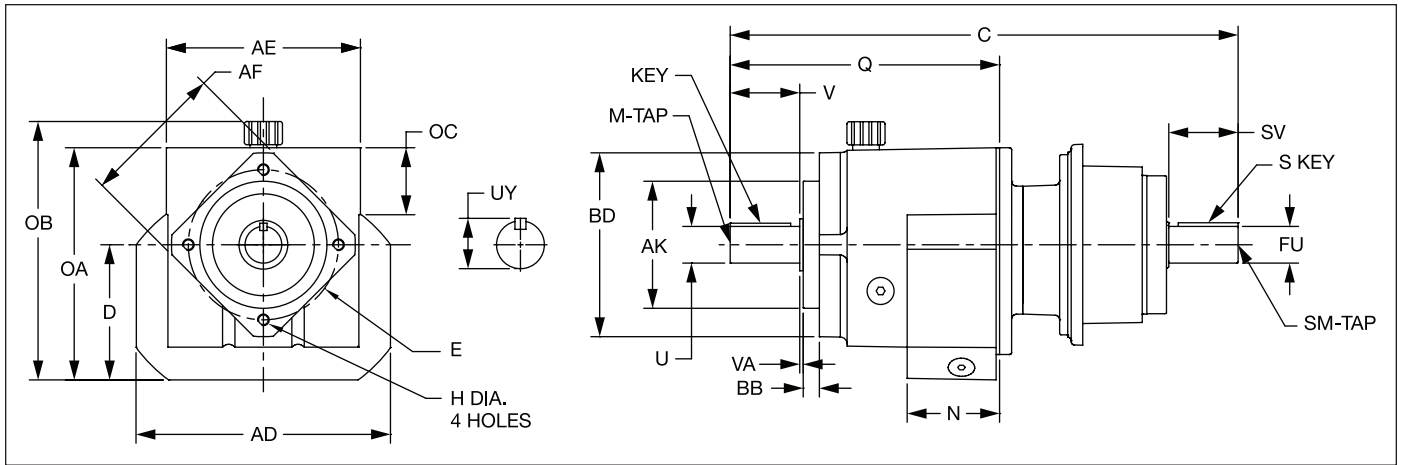

Size	Frame Size	C		OB	OA	D	AD	AE	H	E	Q	OC	BD	AK	N	VA	BB	Input Shaft Dimensions			
		Double	Triple															FU	SV	S KEY	SM-TAP
HF38	71	13.43	14.02	—	6.29	3.62	6.45	5.07	M8 x 0.43 Deep	3.94	7.48	1.83	4.72	3.15	2.32	0.12	0.39	0.625	1.57	3/16 x 3/16 x 1-5/16	8-32 UNC x 0.49
	80	14.80	15.40															0.750	1.57	3/16 x 3/16 x 1-5/16	1/4-20 UNC x 0.63
	90	15.20	15.79															0.875	1.97	3/16 x 3/16 x 1-5/8	5/16-18 UNC x 0.75
	100	15.83	—															1.125	2.36	1/4 x 1/4 x 2	3/8-16 UNC x 0.87
HF48	71	14.84	15.59	8.86	8.11	4.61	8.66	6.61	M10 x 0.63 Deep	5.12	9.17	2.31	6.30	4.33	2.76	0.12	0.59	0.625	1.57	3/16 x 3/16 x 1-5/16	8-32 UNC x 0.49
	80	16.30	16.97															0.750	1.57	3/16 x 3/16 x 1-5/16	1/4-20 UNC x 0.63
	90	16.69	17.34															0.875	1.97	3/16 x 3/16 x 1-5/8	5/16-18 UNC x 0.75
	100	17.32	18.19															1.125	2.36	1/4 x 1/4 x 2	3/8-16 UNC x 0.87
HF68	71	16.89	17.60	10.68	9.93	—	10.39	8.14	M12 x 0.67 Deep	6.50	11.38	2.97	7.48	5.12	3.27	—	0.55	0.625	1.57	3/16 x 3/16 x 1-5/16	8-32 UNC x 0.49
	80	18.27	18.98															0.750	1.57	3/16 x 3/16 x 1-5/16	1/4-20 UNC x 0.63
	90	18.66	19.37															0.875	1.97	3/16 x 3/16 x 1-5/8	5/16-18 UNC x 0.75
	100	19.29	20.00															1.125	2.36	1/4 x 1/4 x 2	3/8-16 UNC x 0.87
HF88	71	—	20.32	13.22	12.47	7.17	13.07	10.23	M16 x 0.87 Deep	8.47	14.41	3.62	9.65	7.09	4.25	—	0.71	0.625	1.57	3/16 x 3/16 x 1-5/16	8-32 UNC x 0.49
	80	—	21.70															0.750	1.57	3/16 x 3/16 x 1-5/16	1/4-20 UNC x 0.63
	90	21.11	22.09															0.875	1.97	3/16 x 3/16 x 1-5/8	5/16-18 UNC x 0.75
	100	21.62	22.72															1.125	2.36	1/4 x 1/4 x 2	3/8-16 UNC x 0.87
HF88	112	21.54	22.68	13.22	12.47	7.17	13.07	10.23	M16 x 0.87 Deep	8.47	14.41	3.62	9.65	7.09	4.25	—	0.71	1.250	2.36	5/16 x 5/16 x 2-1/16	3/8-16 UNC x 0.87
	132	24.88	25.99															1.375	3.15	5/16 x 5/16 x 2-3/4	3/8-16 UNC x 1.10
	160	26.58	—															1.625	4.33	3/8 x 3/8 x 3-1/2	5/8-11 UNC x 1.42

Standard Output Shaft

Size	U	Tolerance	UY	V	Key	M-Tap x Depth
38	1.000	+0.0000/ -0.0005	1.11	1.97	1/4 x 1/4 x 1-5/8	3/8-16 UNC x 0.87
48	1.250	+0.0000/ -0.0005	1.36	2.36	1/4 x 1/4 x 2	3/8-16 UNC x 0.87
68	1.625	+0.0000/ -0.0010	1.79	3.15	3/8 x 3/8 x 2-5/8	5/8-11 UNC x 1.42
88	2.125	+0.0000/ -0.0010	2.35	3.94	1/2 x 1/2 x 3-1/4	3/4-10 UNC x 1.65

Optional Output Shaft

Size	U	Tolerance	UY	V	Key	M-Tap x Depth
38	1.250	+0.0000/ -0.0005	1.36	2.36	1/4 x 1/4 x 2	3/8-16 UNC x 0.87
48	1.625	+0.0000/ -0.0005	1.79	3.15	3/8 x 3/8 x 2-5/8	5/8-11 UNC x 1.42
68	2.125	+0.0000/ -0.0010	2.35	3.94	1/2 x 1/2 x 3-1/4	3/4-10 UNC x 1.65
88	2.375	+0.0000/ -0.0010	2.65	4.72	5/8 x 5/8 x 3-15/16	3/4-10 UNC x 1.65

HF30 Reducer

900 Series Single Reduction

900 Series Double Reduction

Accessories

Ratio Multipliers

In-Line Helical (ILH)

Universal Series Single Reduction

Universal Series Double Reduction

Engineering

In-Line Helical Reducer (ILH)

HF B5 Separate Input - Double and Triple Reduction

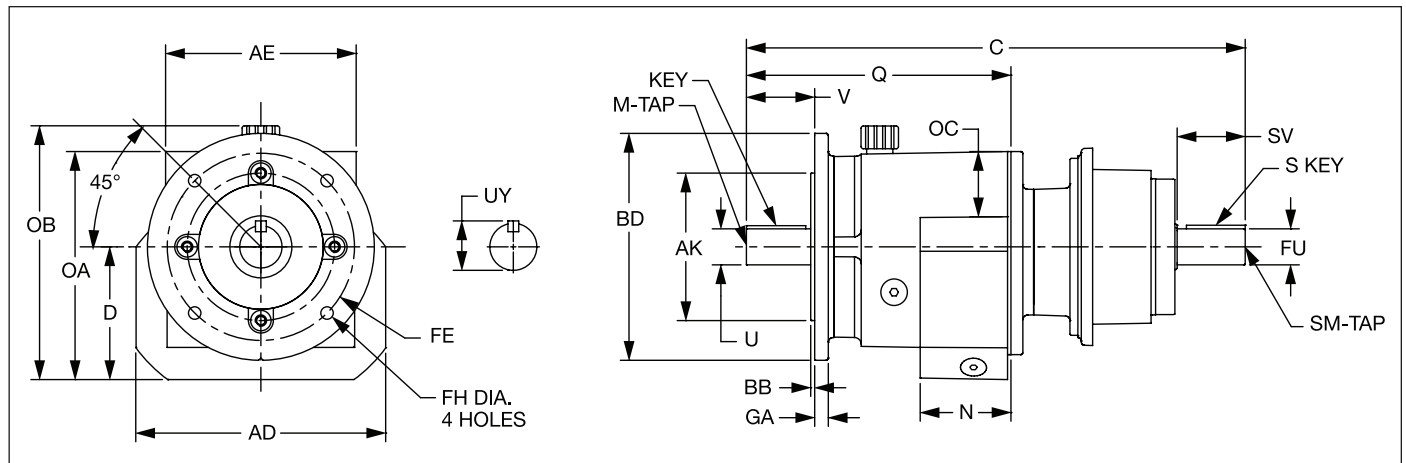

Size	Frame Size	C		OB	OA	D	AD	AE	FH	FE	Q	OC	BD	AK	N	BB	GA	Input Shaft Dimensions			
		Double	Triple															FU	SV	S KEY	SM-TAP
HF38	71	13.43	14.02	—	6.29	3.62	6.45	5.07	0.35	5.12	7.48	1.83	6.30	4.33	2.32	0.14	0.39	0.625	1.57	3/16 x 3/16 x 1-5/16	8-32 UNC x 0.49
	80	14.80	15.40															0.750	1.57	3/16 x 3/16 x 1-5/16	1/4-20 UNC x 0.63
	90	15.20	15.79															0.875	1.97	3/16 x 3/16 x 1-5/8	5/16-18 UNC x 0.75
	100	15.83	—															1.125	2.36	1/4 x 1/4 x 2	3/8-16 UNC x 0.87
HF48	71	14.84	15.59	8.86	8.11	4.61	8.66	6.61	0.43	6.50	9.17	2.31	7.87	5.12	2.76	0.14	0.47	0.625	1.57	3/16 x 3/16 x 1-5/16	8-32 UNC x 0.49
	80	16.30	16.97															0.750	1.57	3/16 x 3/16 x 1-5/16	1/4-20 UNC x 0.63
	90	16.69	17.34															0.875	1.97	3/16 x 3/16 x 1-5/8	5/16-18 UNC x 0.75
	100	17.32	18.19															1.125	2.36	1/4 x 1/4 x 2	3/8-16 UNC x 0.87
HF68	112	17.36	—	10.68	9.93	—	10.39	8.14	0.53	8.47	11.38	2.97	9.84	7.09	3.27	0.16	0.59	1.250	2.36	5/16 x 5/16 x 2-1/16	3/8-16 UNC x 0.87
	71	16.89	17.60															0.625	1.57	3/16 x 3/16 x 1-5/16	8-32 UNC x 0.49
	80	18.27	18.98															0.750	1.57	3/16 x 3/16 x 1-5/16	1/4-20 UNC x 0.63
	90	18.66	19.37															0.875	1.97	3/16 x 3/16 x 1-5/8	5/16-18 UNC x 0.75
HF88	100	19.29	20.00	13.22	12.47	7.17	13.07	10.23	0.53	10.43	14.41	3.62	11.81	9.06	4.25	0.16	0.63	1.125	2.36	1/4 x 1/4 x 2	3/8-16 UNC x 0.87
	112	19.25	—															1.250	2.36	5/16 x 5/16 x 2-1/16	3/8-16 UNC x 0.87
	132	22.56	—															1.375	2.36	5/16 x 5/16 x 2-1/16	3/8-16 UNC x 0.87
	71	—	20.32															0.625	1.57	3/16 x 3/16 x 1-5/16	8-32 UNC x 0.49
	80	—	21.70															0.750	1.57	3/16 x 3/16 x 1-5/16	1/4-20 UNC x 0.63
	90	21.11	22.09															0.875	1.97	3/16 x 3/16 x 1-5/8	5/16-18 UNC x 0.75
HF88	100	21.62	22.72	13.22	12.47	7.17	13.07	10.23	0.53	10.43	14.41	3.62	11.81	9.06	4.25	0.16	0.63	1.125	2.36	1/4 x 1/4 x 2	3/8-16 UNC x 0.87
	112	21.54	22.68															1.250	2.36	5/16 x 5/16 x 2-1/16	3/8-16 UNC x 0.87
	132	24.88	25.99															1.375	3.15	5/16 x 5/16 x 2-3/4	3/8-16 UNC x 1.10
	160	26.58	—															1.625	4.33	3/8 x 3/8 x 3-1/2	5/8-11 UNC x 1.42

Standard Output Shaft

Size	U	Tolerance	UY	V	Key	M-Tap x Depth
38	1.000	+0.0000/-0.0005	1.11	1.97	1/4 x 1/4 x 1-5/8	3/8-16 UNC x 0.87
48	1.250	+0.0000/-0.0005	1.36	2.36	1/4 x 1/4 x 2	3/8-16 UNC x 0.87
68	1.625	+0.0000/-0.0010	1.79	3.15	3/8 x 3/8 x 2-5/8	5/8-11 UNC x 1.42
88	2.125	+0.0000/-0.0010	2.35	3.94	1/2 x 1/2 x 3-1/4	3/4-10 UNC x 1.65

Optional Output Shaft

Size	U	Tolerance	UY	V	Key	M-Tap x Depth
38	1.250	+0.0000/-0.0005	1.36	2.36	1/4 x 1/4 x 2	3/8-16 UNC x 0.87
48	1.625	+0.0000/-0.0005	1.79	3.15	3/8 x 3/8 x 2-5/8	5/8-11 UNC x 1.42
68	2.125	+0.0000/-0.0010	2.35	3.94	1/2 x 1/2 x 3-1/4	3/4-10 UNC x 1.65
88	2.375	+0.0000/-0.0010	2.65	4.72	5/8 x 5/8 x 3-15/16	3/4-10 UNC x 1.65

Inline Helical

Inline Helical C-Face Reducers – Overhung Load (OHL)

1. Calculation based on bearing life

$$F_x \text{ perm.}_1 = F_R \text{ perm} \frac{y}{Z + X} \quad [\text{lb}_f]$$

2. Calculation based on mechanical strength

$$F_x \text{ perm.}_2 = \frac{a}{b + x} \quad [\text{lb}_f]$$

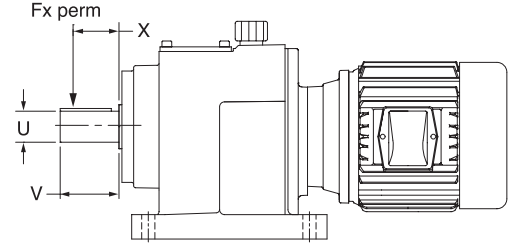

The data in the table below lists the permissible output shaft overhung load (OHL) when the load is located at med-shaft. To calculate the permissible OHL when the load is located at other positions, use the formulas above along with the data below.

Both equations 1 and 2 must be used to determine if the bearing or shaft strength limits the OHL. Limit the OHL to the lower of the 2 calculations.

								FR perm. (lbf) for x = v/2 for output speeds n2 in RPM							
Type Stages	y in (mm)	z in (mm)	a lbf-in (kN-mm)	b in (mm)	u in (mm)	v in (mm)	*	n2 ≤ 16	n2 ≤ 25	n2 ≤ 40	n2 ≤ 63	n2 ≤ 100	n2 ≤ 160	n2 ≤ 250	≤ 400
H_38 (2/3)	4.173	3.189	1496	0	1.000	1.97	ccw	1695	1432	1234	881	546	416	279	250
	(106)	(81)	(169)	(0)	(25)	(50)	cw	1625	1360	1167	937	710	569	407	385
	4.370	3.189	1859	0.630	1.250	2.36	ccw	1619	1358	1117	762	472	360	241	230
H_48 (2/3)	5.315	4.134	2346	0	1.250	2.36	ccw	2810	2354	1992	1517	1142	937	919	617
	(135)	(105)	(265)	(0)	(30)	(60)	cw	2700	2246	1884	1533	1270	1095	967	779
	5.709	4.134	4417	0.748	1.625	3.15	ccw	2617	2192	1801	1293	973	798	785	529
H_68 (2/3)	6.693	5.098	4992	0	1.625	3.15	ccw	3844	3091	2765	1940	1306	962	1057	763
	(170)	(129.50)	(564)	(0)	(40)	(80)	cw	4186	3437	3174	2347	1715	1344	1308	986
	7.087	5.098	8346	0.906	2.125	3.94	ccw	3516	2828	2529	1774	1194	879	967	677
H_88 (2/3)	8.228	6.260	9559	0	2.125	3.94	ccw	7915	6643	5712	4773	3437	2954	2252	2700
	(209)	(159)	(1080)	(0)	(50)	(100)	cw	7609	6337	5346	4471	3599	3087	2605	2507
	8.622	6.260	13569	0.827	2.375	4.72	ccw	7553	6339	5451	4554	3325	2855	2178	2543
	(219)	(159)	(1533)	(21)	(60)	(120)	cw	7261	6047	5101	4267	3435	2945	2486	2392

								FR perm. (lbf) for x = v/2 for output speeds n2 in RPM															
Type Stages	y in (mm)	z in (mm)	a lbf-in (kN-mm)	b in (mm)	u in (mm)	v in (mm)	*	≤ 16	≤ 25	≤ 40	≤ 63	≤ 100	≤ 160	≤ 250	≤ 400								
H_38 (2/3)	4.173	3.189	1100	0	1.000	1.97	ccw	NOT AVAILABLE															
	(106)	(81)	(124.3)	(0)	(25)	(50)	cw																
	4.370	3.189	1859	0.630	1.250	2.36	ccw																
H_48 (2/3)	5.315	4.134	2346	0	1.250	2.36	ccw																
	(135)	(105)	(265)	(0)	(30)	(60)	cw																
	5.709	4.134	4417	0.748	1.625	3.15	ccw																
H_68 (2/3)	6.693	5.098	4992	0	1.625	3.15	ccw									5528	5358	5183	5019	4857	4723	4618	4480
	(170)	(129.50)	(564)	(0)	(40)	(80)	cw									5528	5358	5184	5021	4861	4682	4457	4108
	7.087	5.098	7019	0.906	2.125	3.94	ccw									6127	5934	5738	5557	5372	5201	4779	4231
H_88 (2/3)	8.228	6.260	9559	0	2.125	3.94	ccw									8111	7859	7273	5659	4226	4886	5089	4752
	(209)	(159)	(1080)	(0)	(50)	(100)	cw									8111	7859	7606	7364	7311	6944	6819	6141
	8.622	6.260	13569	0.827	2.375	4.72	ccw									9114	8249	6520	5077	3792	4381	4559	4263
	(219)	(159)	(1533)	(21)	(60)	(120)	cw	9109	8819	8519	8240	7732	7231	6664	5858								

* Direction of rotation with view on output shaft
1N = 0.2248 lbf

bold = Standard Shaft
cw = clockwise

ccw = counter clockwise

Universal Series Single Reduction

Style Reference Guide	148
How to Order	149
Selection Process	150
Ratings Tables	151 - 154
Dimensions	155 - 161
Optional Bases	162

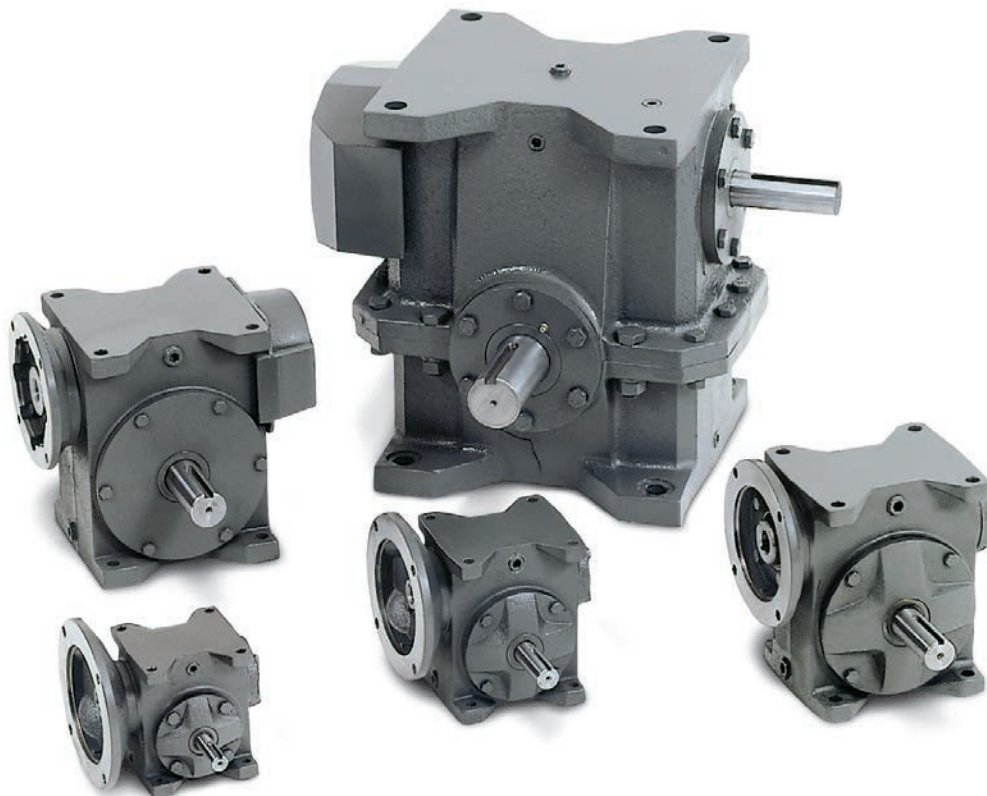

H50
Reducer

900 Series
Single Reduction

900 Series
Double Reduction

Accessories

Ratio Multiplier

In-Line Helical (LH)

Universal Series
Single Reduction

Universal Series
Double Reduction

Engineering

Universal Series Style Reference Guide

Single Reduction

STF

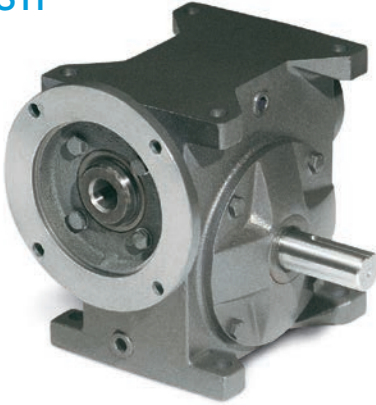

Ratings P. 151 - 154
Dimensions P. 155

SVF



Ratings P. 151 - 154
Dimensions P. 156

ST



Ratings P. 151 - 154
Dimensions P. 157

SB



Ratings P. 151 - 154
Dimensions P. 158

SV

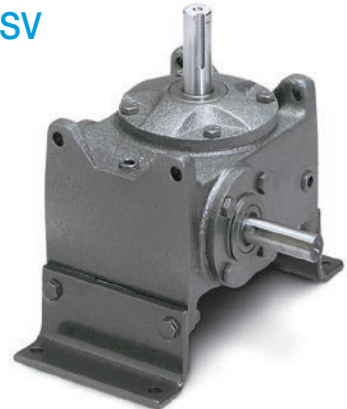

Ratings P. 151 - 154
Dimensions P. 159

STL

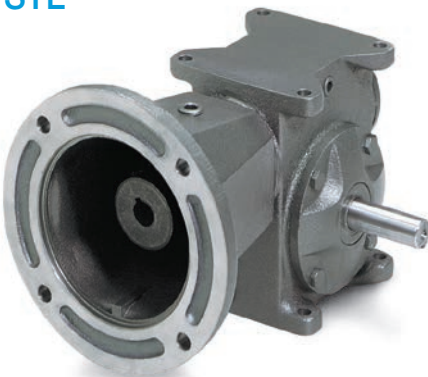

Ratings P. 151 - 154
Dimensions P. 160

SVL

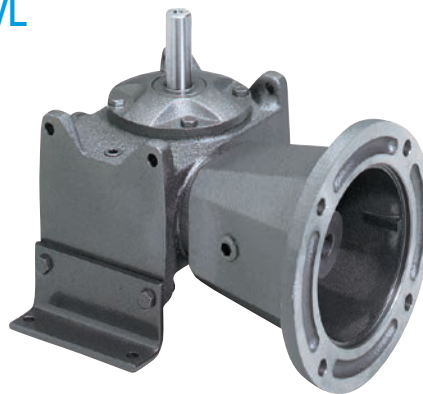

Ratings P. 151 - 154
Dimensions P. 161

Universal Series Numbering System/How to Order

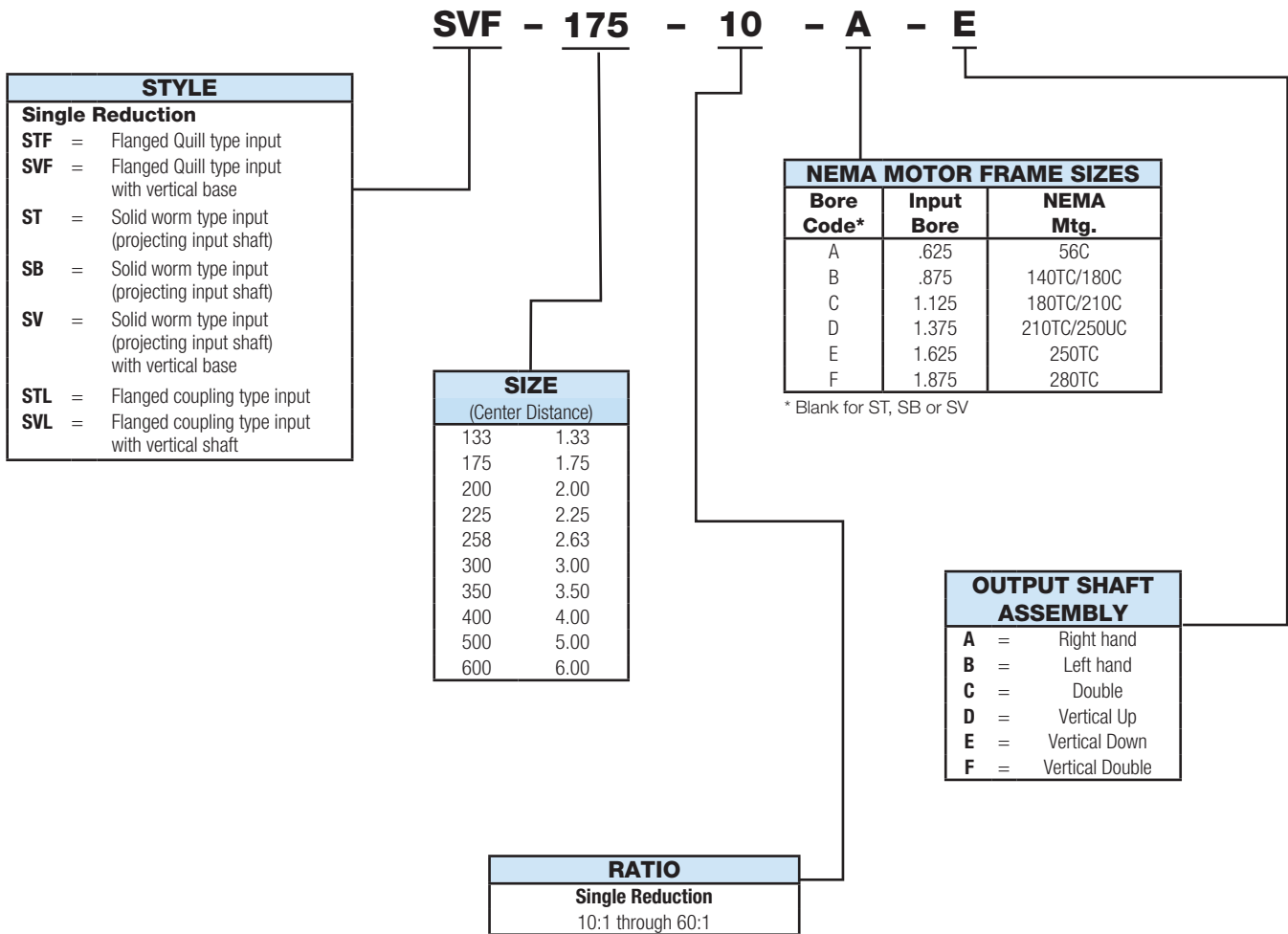

HOW TO ORDER

Please specify Style, Size, Base (if required), Ratio, NEMA Input Flange (if flanged reducer), Output shaft assembly.

EXAMPLE

Required size, 175, Quill type input, 10:1, 56C, vertical shaft down

Order **SVF-175-10-A-E** or **GSF1018AA** with Vertical Base Kit **B1317V81** from stock.

Universal Series Selection Procedure

REQUIRED INFORMATION

To select the proper reducer for a given application, several important factors should be taken into consideration. They are: Application, Horsepower, Torque, Ratio and Overhung Load.

Note: See Engineering Information page 185 for detailed information and calculations on horsepower, torque, ratio and overhung load.

CLASS OF SERVICE (APPLICATION)

The horsepower, torque and overhung load ratings shown in the catalog are based on a service factor of 1.0. For applications conforming to a 1.0 service factor, the catalog ratings may be used directly. For applications not conforming to a 1.0 service factor, the catalog rating must be divided by the appropriate service factor from the service factor table. The catalog ratings may be used directly if the actual application horsepower and torque requirements are multiplied by the appropriate service factor.

SERVICE FACTORS

Prime Mover	Duration of Service Total Operating Time per Day	Driven Machine Load Classifications		
		Uniform	Moderate Shock	Heavy Shock
Electric Motor	Occasional 1/2 Hour	0.80	0.90	1.00
	Intermittent 2 Hours	0.90	1.00	1.25
	10 Hours	1.00	1.25	1.50
	24 Hours	1.25	1.50	1.75
Multi-Cylinder Internal Combustion Engine	Occasional 1/2 Hour	0.90	1.00	1.25
	Intermittent 2 Hours	1.00	1.25	1.50
	10 Hours	1.25	1.50	1.75
	24 Hours	1.50	1.75	2.00
Single Cylinder Internal Combustion Engine	Occasional 1/2 Hour	1.00	1.25	1.50
	Intermittent 2 Hours	1.25	1.50	1.75
	10 Hours	1.50	1.75	2.00
	24 Hours	1.75	2.00	2.25

Service Factors for Applications Involving Frequent Stops and Starts – More than 10 Starts Per Hour

Electric Motor	Occasional 1/2 Hour	0.90	1.00	1.25
	Intermittent 2 Hours	1.00	1.25	1.50
	10 Hours	1.25	1.50	1.75
	24 Hours	1.50	1.75	2.00

SELECTION PROCEDURE

- Step 1. Select appropriate service factor.
- Step 2. Multiply actual application output torque or horsepower required by service factor to obtain design horsepower or torque.
- Step 3. Determine appropriate reducer ratio based on input speed and required output speed.
- Step 4. Select proper size reducer, based on horsepower and/or torque, service factor and ratio.
- Step 5. Determine whether overhung load capacity of reducer selected exceeds actual overhung load of drive.
 - Step 6. a. Determine proper mounting arrangement.
 - b. For C-flange (motorized) reducers determine proper catalog designation to accommodate the frame number of the number of the motor to be used.

SELECTION EXAMPLE

Selection the correct C-flange (motorized) reducer to drive a package conveyor, based on the following requirements.

- a. Eight hours continuous service per 24 hours, no shock loading.
- b. 1 HP, 1750 rpm motor, 56C frame, 875 in. lbs. output torque required.
- c. 58 output rpm required.
- d. 4.193" pitch diameter sprocket on output shaft.
- e. Input worm over single left-hand output shaft, floor mount.

Step 1. Eight hour service, no shock loading indicates use of 1.00 service factor.

Step 2. 1 HP x 1.00 service factor = 1.00 design HP.

875 in. lbs. x 1.00 = 875 in. lbs. output torque capacity required.

Step 3. Determine ratio:

$$\text{Ratio} = \frac{\text{Input RPM}}{\text{Output RPM}} = \frac{1750}{58} = 30.2, \text{ use } 30:1$$

Step 4. Refer to catalog rating tables, smallest unit capable of handling 1.00 input HP, 875 in. lbs. output torque at 30:1 ratio is size 258.

Step 5. Determine whether overhung load of drive exceeds capacity of reducer selected;

$$\text{OHL} = \frac{\text{Torque} \times \text{K}}{\text{r (sprocket radius)}} = \frac{875 \times 1.00}{2.097} = 418 \text{ Lbs}^*$$

See Engineering pg. 185 for Constants

418 pounds is well below the 900 pounds overhung load rating of the reducer selected.

Step 6. Worm over, left hand output extension conforms to Assembly Type B. Use STF-258-30-A-B which has a 30:1 ratio and a motor mounting flange and input bore to accommodate a NEMA 56C motor.

As an alternative to the above, a two-to-one sprocket reduction could be used. With a 21-tooth sprocket on the output shaft and a 42-tooth sprocket on the driven shaft, the torque at the reducer output has been cut in half to 438 lb. in. The reducer ratio requirement has also been cut in half to 15:1. (15:1 reducer x 2:1 sprocket set = 30:1 total)

Now the drive requires a reducer of 15:1 ratio, 438 lb. in. torque capability and an overhung load of 209 lbs.

$$\text{OHL} = \frac{438(T) \times 1(K)}{2.097 \text{ (sprocket radius)}} = 209 \text{ lbs. (See Engineering pg. 185)}$$

This requirement can be filled by Baldor's STF-200-30-A-B. It has an output torque capacity of 605 lbs. in. and an overhung load rating of 600 lbs.

By using the 2:1 secondary sprocket reduction, the reducer size has been reduced to two full sizes and an approximately 25% reduction in reducer cost.

*If using output horsepower instead of torque to determine overhung load, use formula:

$$\text{OHL} = \frac{\text{HP} \times 63,025 \times \text{K}}{\text{N} \times \text{R}} = \text{(See Engineering pg. 185)}$$

Universal Series Single Reduction Ratio and Capacity Selection Tables

Horsepower & Torque Ratings for Service Class I (1.0 Service Factor)

Ratio	Input RPM	Output RPM	SIZE 133			SIZE 175			SIZE 200		
			Input Hp	Output Hp	Output Torque In. Lbs.	Input Hp	Output Hp	Output Torque In. Lbs.	Input Hp	Output Hp	Output Torque In. Lbs.
10	2400	240.0	0.744	0.663	174	1.297	1.174	308	1.988	1.824	479
	1750	175.0	0.640	0.576	207	1.220	1.100	396	1.770	1.590	572
	1150	115.0	0.485	0.437	229	0.950	0.855	449	1.360	1.220	641
	850	85.0	0.390	0.351	246	0.775	0.697	488	1.120	1.000	700
	100	10.0	0.059	0.053	334	0.121	0.109	687	0.175	0.158	995
15	2400	160.0	0.556	0.473	186	0.947	0.821	323	1.484	1.318	519
	1750	116.7	0.465	0.409	221	0.875	0.770	416	1.280	1.120	605
	1150	76.7	0.345	0.303	239	0.665	0.585	461	0.980	0.862	679
	850	56.7	0.285	0.251	264	0.554	0.487	511	0.805	0.708	743
	100	6.7	0.043	0.037	350	0.087	0.076	719	0.127	0.111	1050
20	2400	120.0	0.447	0.363	191	0.774	0.647	340	1.181	1.014	532
	1750	87.5	0.360	0.306	220	0.685	0.582	419	1.000	0.850	612
	1150	57.5	0.270	0.229	240	0.520	0.442	464	0.760	0.646	678
	850	42.5	0.220	0.187	262	0.430	0.365	511	0.625	0.531	743
	100	5.0	0.033	0.028	353	0.067	0.057	718	0.098	0.083	1046
25	2400	96.0	0.377	0.293	192	0.624	0.497	326	0.987	0.820	538
	1750	70.0	0.295	0.242	218	0.550	0.451	406	0.815	0.668	601
	1150	46.0	0.220	0.180	236	0.420	0.344	451	0.625	0.512	672
	850	34.0	0.180	0.147	257	0.350	0.287	502	0.512	0.420	735
	100	4.0	0.027	0.022	347	0.055	0.045	709	0.090	0.074	1166
30	2400	80.0	0.328	0.244	192	0.564	0.436	343	0.852	0.685	540
	1750	58.3	0.247	0.198	214	0.470	0.376	406	0.729	0.584	631
	1150	38.3	0.186	0.149	235	0.360	0.288	454	0.520	0.416	655
	850	28.3	0.152	0.122	256	0.295	0.236	495	0.430	0.344	722
	100	3.3	0.023	0.018	344	0.043	0.034	649	0.068	0.054	1031
40	2400	60.0	0.264	0.181	190	0.449	0.323	339	0.672	0.509	534
	1750	43.8	0.190	0.143	206	0.360	0.270	389	0.525	0.394	568
	1150	28.8	0.142	0.107	225	0.275	0.206	433	0.400	0.300	630
	850	21.3	0.115	0.085	241	0.226	0.170	476	0.330	0.248	694
	100	21.3	0.016	0.012	302	0.036	0.027	680	0.052	0.039	983
50	2400	48.0	0.220	0.140	183	0.358	0.238	312	0.549	0.392	515
	1750	35.0	0.152	0.106	191	0.286	0.200	360	0.425	0.298	536
	1150	23.0	0.115	0.081	213	0.220	0.154	404	0.323	0.226	593
	850	17.0	0.094	0.066	231	0.180	0.126	441	0.265	0.186	651
	100	2.0	0.014	0.010	315	0.028	0.020	630	0.042	0.029	914
60	2400	40.0	0.186	0.111	174	0.311	0.197	310	0.459	0.310	488
	1750	29.2	0.128	0.083	180	0.244	0.159	343	0.360	0.234	505
	1150	19.2	0.096	0.062	195	0.187	0.126	397	0.270	0.176	554
	850	14.2	0.078	0.051	214	0.153	0.099	416	0.220	0.143	600
	100	1.7	0.011	0.007	276	0.024	0.015	591	0.035	0.023	906
OVERHUNG LOAD*			INPUT SHAFT 155 LBS. OUTPUT SHAFT 280 LBS.			INPUT SHAFT 155 LBS. OUTPUT SHAFT 460 LBS.			INPUT SHAFT 225 LBS. OUTPUT SHAFT 650 LBS.		
OUTPUT SHAFT THRUST LOAD			300 LBS.			400 LBS.			600 LBS.		
MAXIMUM INPUT SPEED			4500 RPM			3600 RPM			3600 RPM		

*Overhung Load Rating is at center of shaft extension with no thrust load.

H50 Reducer
900 Series Single Reduction
900 Series Double Reduction
Accessories
Ratio Multiplier
In-Line Helical (L-H)
Universal Series Single Reduction
Universal Series Double Reduction
Engineering

Universal Series Single Reduction Ratio and Capacity Selection Tables

Horsepower & Torque Ratings for Service Class I (1.0 Service Factor)

Ratio	Input RPM	Output RPM	SIZE 225			SIZE 258			SIZE 300		
			Input Hp	Output Hp	Output Torque In. Lbs.	Input Hp	Output Hp	Output Torque In. Lbs.	Input Hp	Output Hp	Output Torque In. Lbs.
10	2400	240.0	2.631	2.431	638	3.984	3.701	972	5.252	4.680	1229
	1750	175.0	2.440	2.190	788	3.430	3.080	1109	4.400	3.960	1426
	1150	115.0	1.860	1.670	877	2.650	2.380	1250	3.530	3.170	1664
	850	85.0	1.530	1.370	959	2.200	1.980	1386	2.950	2.650	1855
	100	10.0	0.243	0.219	1380	0.365	0.328	2066	0.510	0.460	2898
15	2400	160.0	1.939	1.750	689	2.955	2.672	1052	3.939	3.351	1320
	1750	116.7	1.840	1.620	875	2.500	2.200	1188	3.250	2.860	1544
	1150	76.7	1.390	1.220	961	1.940	1.700	1340	2.580	2.270	1789
	850	56.7	1.140	1.000	1050	1.600	1.410	1481	2.160	1.900	1995
	100	6.7	0.176	0.155	1466	0.260	0.228	2156	0.368	0.324	3065
20	2400	120.0	1.564	1.360	714	2.348	2.060	1082	3.088	2.508	1317
	1750	87.5	1.350	1.150	828	1.920	1.630	1174	2.520	2.140	1541
	1150	57.5	1.040	0.884	928	1.480	1.260	1323	2.020	1.710	1796
	850	42.5	0.850	0.722	1011	1.230	1.040	1456	1.680	1.430	2002
	100	5.0	0.136	0.115	1449	0.202	0.171	2154	0.285	0.242	3049
25	2400	96.0	1.294	1.098	721	1.955	1.673	1098	2.577	2.003	1315
	1750	70.0	1.090	0.904	814	1.520	1.250	1125	2.080	1.710	1539
	1150	46.0	0.825	0.676	887	1.180	0.967	1269	1.650	1.350	1771
	850	34.0	0.685	0.561	981	0.985	0.807	1412	1.380	1.130	1978
	100	4.0	0.111	0.091	1433	0.165	0.135	2126	0.235	0.193	3040
30	2400	80.0	1.110	0.917	722	1.675	1.397	1100	2.189	1.629	1283
	1750	58.3	0.980	0.784	847	1.350	1.080	1166	1.740	1.390	1501
	1150	38.3	0.745	0.596	939	1.040	0.832	1310	1.390	1.110	1748
	850	28.3	0.610	0.488	1025	0.860	0.688	1445	1.160	0.928	1949
	100	3.3	0.094	0.075	1432	0.140	0.112	2138	0.196	0.157	2997
40	2400	60.0	0.882	0.682	716	1.319	1.036	1088	1.744	1.196	1256
	1750	43.8	0.710	0.536	772	1.010	0.760	1095	1.360	1.020	1470
	1150	28.8	0.545	0.409	859	0.780	0.585	1229	1.080	0.810	1701
	850	21.3	0.450	0.338	946	0.645	0.484	1355	0.900	0.675	1890
	100	21.3	0.072	0.054	1361	0.106	0.080	2016	0.153	0.115	2898
50	2400	48.0	0.709	0.526	690	1.054	0.685	900	1.381	0.879	1154
	1750	35.0	0.550	0.385	693	0.790	0.553	995	1.070	0.750	1350
	1150	23.0	0.430	0.301	790	0.615	0.431	1131	0.850	0.595	1562
	850	17.0	0.354	0.248	868	0.510	0.357	1250	0.710	0.497	1740
	100	2.0	0.058	0.041	1291	0.086	0.060	1890	0.118	0.083	2615
60	2400	40.0	0.590	0.416	656	0.952	0.571	900	1.072	0.640	1008
	1750	29.2	0.510	0.325	702	0.695	0.452	976	0.840	0.546	1179
	1150	19.2	0.385	0.250	788	0.525	0.341	1074	0.670	0.436	1373
	850	14.2	0.315	0.205	861	0.445	0.290	1218	0.560	0.364	1529
	100	1.7	0.049	0.032	1260	0.072	0.047	1851	0.094	0.061	2402
OVERHUNG LOAD*			INPUT SHAFT 225 LBS. OUTPUT SHAFT 870 LBS.			INPUT SHAFT 414 LBS. OUTPUT SHAFT 1200 LBS.			INPUT SHAFT 414 LBS. OUTPUT SHAFT 1575 LBS.		
OUTPUT SHAFT THRUST LOAD			750 LBS.			900 LBS.			1100 LBS.		
MAXIMUM INPUT SPEED			3600 RPM			3600 RPM			3600 RPM		

*Overhung Load Rating is at center of shaft extension with no thrust load.

Universal Series Single Reduction Ratio and Capacity Selection Tables

Horsepower & Torque Ratings for Service Class I (1.0 Service Factor)

Ratio	Input RPM	Output RPM	SIZE 350 FC			SIZE 400 FC			SIZE 500 FC		
			Input Hp	Output Hp	Output Torque In. Lbs.	Input Hp	Output Hp	Output Torque In. Lbs.	Input Hp	Output Hp	Output Torque In. Lbs.
10	2400	240.0	8.320	7.758	2036	11.305	10.587	2779	19.105	17.983	4721
	1750	175.0	6.680	5.940	2138	9.770	8.690	3128	17.600	15.660	5638
	1150	115.0	5.800	5.160	2709	8.420	7.500	3938	15.000	13.350	7009
	850	85.0	5.030	4.470	3129	7.210	6.410	4487	13.000	11.570	8099
	100	10.0	0.877	0.780	4914	1.350	1.200	7560	2.590	2.300	14490
15	2400	160.0	6.167	5.594	2203	8.503	7.771	3060	14.140	13.000	5118
	1750	116.7	5.350	4.650	2525	7.350	6.380	3464	13.220	11.370	6122
	1150	76.7	4.640	4.030	3171	6.430	5.600	4407	11.540	9.920	7812
	850	56.7	4.030	3.500	3675	5.560	4.830	5071	10.200	8.700	9212
	100	6.7	0.716	0.623	5946	1.020	0.880	8400	1.950	1.680	16036
20	2400	120.0	4.869	4.294	2254	6.599	5.866	3080	11.160	9.989	5244
	1750	87.5	3.890	3.300	2363	5.800	4.930	3530	11.100	9.430	6790
	1150	57.5	3.400	2.890	3034	5.090	4.320	4536	9.520	8.090	8495
	850	42.5	2.970	2.520	3528	4.490	3.810	5334	8.350	7.090	9926
	100	5.0	0.562	0.477	5254	0.861	0.732	9223	1.630	1.380	17388
30	2400	80.0	3.533	2.971	2340	4.729	4.016	3162	7.827	6.729	5299
	1750	58.3	2.820	2.250	2443	4.100	3.280	3562	7.820	6.250	6754
	1150	38.3	2.440	1.950	3071	3.600	2.880	4536	6.780	5.420	8536
	850	28.3	2.130	1.700	3570	3.170	2.530	5313	5.830	4.660	9786
	100	3.3	0.394	0.315	6013	0.608	0.486	9278	1.150	0.920	17564
40	2400	60.0	2.711	2.147	2255	3.660	2.943	3091	6.156	5.000	5248
	1750	43.8	2.240	1.680	2405	3.210	2.410	3448	6.050	4.540	6500
	1150	28.8	1.980	1.480	3108	2.860	2.150	4515	5.110	3.830	8043
	850	21.3	1.750	1.310	3750	2.550	1.910	5468	4.310	3.230	9044
	100	2.5	0.347	0.260	6552	0.522	0.391	9853	1.030	0.770	19454
50	2400	48.0	2.249	1.705	2238	2.712	2.056	2700	4.916	3.853	5058
	1750	35.0	1.750	1.220	2196	2.390	1.670	3006	4.950	3.660	6591
	1150	23.0	1.550	1.080	2835	2.140	1.500	3938	4.250	2.970	7796
	850	17.0	1.370	0.960	3360	1.910	1.330	4655	3.620	2.530	8855
	100	2.0	0.279	0.195	6142	0.398	0.278	8757	0.830	0.580	18428
60	2400	40.0	1.847	1.345	2118	1.917	1.396	2200	4.036	3.050	4803
	1750	29.2	1.500	0.980	2128	1.820	1.180	2563	4.050	2.880	6259
	1150	19.2	1.330	0.860	2709	1.630	1.060	3339	3.480	2.260	7119
	850	14.2	1.170	0.760	3192	1.460	0.950	3990	3.120	2.030	8526
	100	1.7	0.230	0.150	5906	0.312	0.203	7993	0.700	0.460	16936
OVERHUNG LOAD*			INPUT SHAFT 1055 LBS. OUTPUT SHAFT 1695 LBS.			INPUT SHAFT 1625 LBS. OUTPUT SHAFT 1950 LBS.			INPUT SHAFT 1330 LBS. OUTPUT SHAFT 2880 LBS.		
OUTPUT SHAFT THRUST LOAD			1200 LBS.			1700 LBS.			2100 LBS.		
MAXIMUM INPUT SPEED			3600 RPM			3600 RPM			3600 RPM		

*Overhung Load Rating is at center of shaft extension with no thrust load.

H50 Reducer

900 Series Single Reduction

900 Series Double Reduction

Accessories

Ratio Multiplier

In-Line Helical (L-H)

Universal Series Single Reduction

Universal Series Double Reduction

Engineering

Universal Series Single Reduction Ratio and Capacity Selection Tables

Horsepower & Torque Ratings for Service Class I (1.0 Service Factor)

Ratio	Input RPM	Output RPM	SIZE 600 FC		
			Input Hp	Output Hp	Output Torque In. Lbs.
10	2400	240.0	28.618	27.026	7094
	1750	175.0	26.130	22.360	8050
	1150	115.0	21.120	18.790	9865
	850	85.0	18.690	16.630	11641
	100	10.0	4.310	3.840	24192
15	2400	160.0	21.051	14.439	7654
	1750	116.7	18.550	15.950	8588
	1150	76.7	15.630	13.440	10584
	850	56.7	13.960	12.000	12605
	100	6.7	3.240	2.780	26536
20	2400	120.0	16.274	14.641	7686
	1750	87.5	14.360	12.210	8791
	1150	57.5	12.150	10.330	10846
	850	42.5	10.890	9.260	12964
	100	5.0	2.660	2.260	28476
30	2400	80.0	11.675	10.124	7973
	1750	58.3	10.330	8.260	8926
	1150	38.3	8.810	7.050	11104
	850	28.3	7.990	6.390	13419
	100	3.3	1.930	1.540	29400
40	2400	60.0	8.958	7.350	7717
	1750	43.8	8.000	6.240	8938
	1150	28.8	6.920	5.190	10890
	850	21.3	6.250	4.680	13104
	100	2.5	1.680	1.260	31752
50	2400	48.0	7.285	5.775	7580
	1750	35.0	7.210	5.410	9742
	1150	23.0	6.000	4.200	11025
	850	17.0	5.160	3.610	12635
	100	2.0	1.410	0.990	31185
60	2400	40.0	5.986	4.593	7234
	1750	29.2	5.350	3.910	8498
	1150	19.2	4.680	3.040	9576
	850	14.2	4.320	2.810	11802
	100	1.7	1.160	0.750	27794
OVERHUNG LOAD*			INPUT SHAFT 1350 LBS. OUTPUT SHAFT 3880 LBS.		
OUTPUT SHAFT THRUST LOAD			2500 LBS.		
MAXIMUM INPUT SPEED			2500 RPM		

* Overhung Load Rating is at center of shaft extension with no thrust load.

H50 Reducer

900 Series Single Reduction

900 Series Double Reduction

Accessories

Ratio Multipliers

In-Line Helical (LH)

Universal Series Single Reduction

Universal Series Double Reduction

Engineering

Style STF

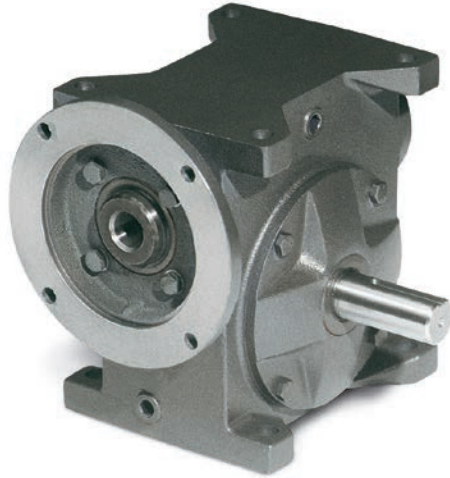

Universal Series Dimensions Single Reduction Flanged Quill Type

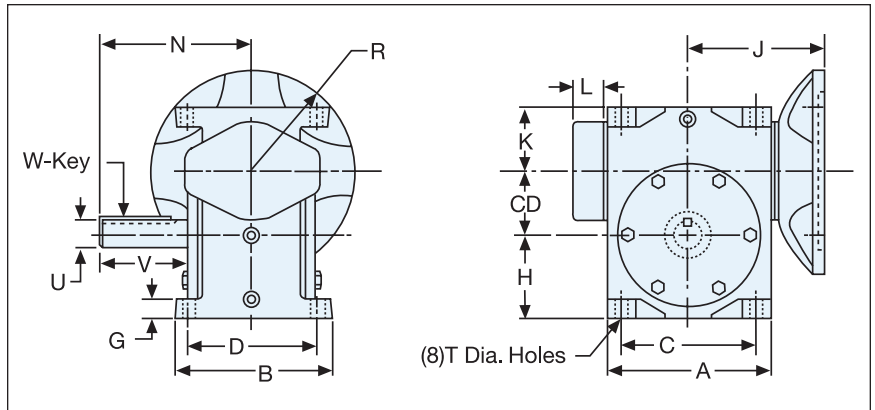

Size	C.D.	A	B	C	D	G	H	J			K	L Fan Guard	N	T Dia.
								56C 140TC	180TC 210C	210TC				
133	1.33	4.25	4.38	3.50	3.63	0.50	2.00	3.88	—	—	1.88	—	4.13	0.343
175	1.75	4.25	4.38	3.50	3.63	0.50	2.38	3.88	—	—	1.88	—	4.25	0.343
200	2.00	5.25	5.00	4.25	4.13	0.63	2.69	4.38	—	—	2.06	—	4.88	0.406
225	2.25	5.25	5.00	4.25	4.13	0.63	2.94	4.38	—	—	2.06	—	5.13	0.343
258	2.63	7.00	6.25	5.63	5.13	0.75	3.25	5.00	6.06	—	2.38	—	5.50	0.531
300	3.00	7.00	6.25	5.63	5.13	0.75	3.63	5.00	6.06	—	2.38	—	5.88	0.531
350	3.50	7.63	7.63	6.38	6.38	0.88	4.13	5.41	6.22	—	2.63	2.13	6.50	0.531
400	4.00	8.63	8.63	7.38	7.38	0.88	4.50	5.94	6.75	6.75	3.00	2.13	7.38	0.531

Size	Output Shaft		W-Key		Motor Size Available Per Size Any Ratio	Approximate Weight Lbs.	Approximate Oil Capacity Oz.
	U +0.000 -0.001	V	Sq.	Lgth.			
133	0.625	1.88	0.187	1.18	A	15.5	5
175	0.750	2.00	0.187	1.31	A, B	17.5	6
200	0.875	2.44	0.187	1.75	A, B	24	10
225	1.000	2.69	0.250	1.88	A, B	27	14
258	1.125	2.63	0.250	1.88	A, B, C	42	32
300	1.250	3.00	0.250	2.25	A, B, C	47	40
350	1.500	3.44	0.375	2.75	A, B, C, D	73	51
400	1.625	3.75	0.375	2.75	A, B, C, D	96	80

Motor Information				
Worm Bore Size Designation	NEMA Design	Bore +0.002 -0.000	Key Way	R
A	56C	0.625	0.187 x 0.093	3.25
B	180C/140TC	0.875	0.187 x 0.093	3.25
C	180TC/210C	1.125	0.250 x 0.125	4.50
D	210TC	1.375	0.312 x 0.156	4.50

Assembly Types End View

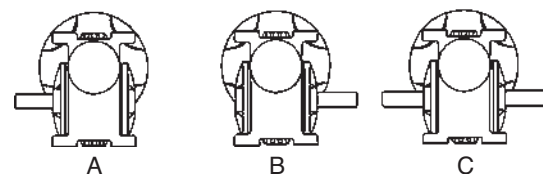

Style SVF

Universal Series Dimensions
Single Reduction Flanged Quill Type

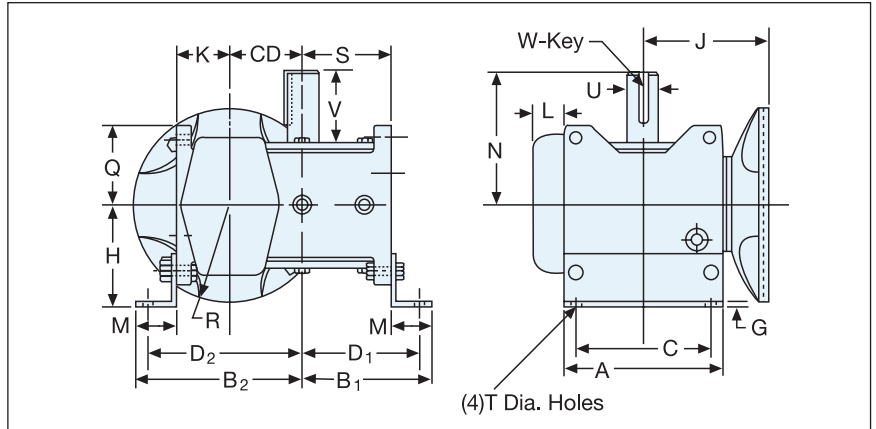
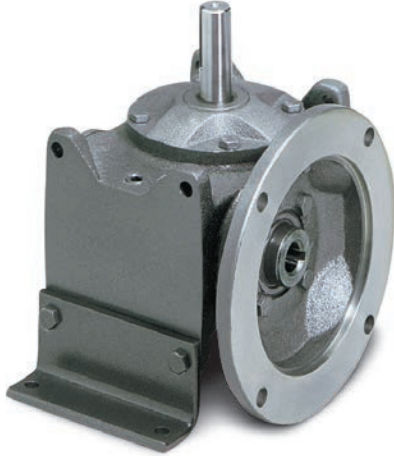

Size	C.D.	A	B ₁	B ₂	C	D ₁	D ₂	G	H		J			K	L	M	N	Q	S	T
									Except 258C & 300C	258C & 300C Only	56C 140TC	180TC 210C	210TC							
133	1.33	4.25	3.31	4.53	3.50	2.88	4.09	0.25	3.38	—	3.88	—	—	1.88	—	1.31	4.13	2.188	2.00	0.343
175	1.75	4.25	3.69	4.94	3.50	3.25	4.50	0.25	3.38	—	3.88	—	—	1.88	—	1.31	4.25	2.188	2.38	0.343
200	2.00	5.25	4.25	5.63	4.25	3.75	5.13	0.25	3.38	—	4.38	—	—	2.06	—	1.56	4.88	2.500	2.69	0.406
225	2.25	5.25	4.50	5.88	4.25	4.00	5.38	0.25	3.38	—	4.38	—	—	2.06	—	1.56	5.13	2.500	2.94	0.406
258	2.63	7.00	5.31	7.06	5.63	4.75	6.50	0.25	3.38	5.38	5.00	6.06	—	2.38	—	2.06	5.50	3.125	3.25	0.531
300	3.00	7.00	5.69	7.44	5.63	5.13	6.88	0.25	3.38	5.38	5.00	6.06	—	2.38	—	2.06	5.88	3.125	3.63	0.531
350	3.50	7.63	6.13	8.13	6.38	5.50	7.50	0.25	4.56	—	5.41	6.22	—	2.63	2.13	2.00	6.50	3.813	4.13	0.531
400	4.00	8.63	6.50	9.00	7.38	5.88	8.38	0.25	5.08	—	5.94	6.75	6.75	3.00	2.13	2.00	7.38	5.313	4.50	0.531

Size	Output Shaft		W-Key		Motor Size Available Per Size Any Ratio	Approximate Weight Lbs.	Approximate Oil Capacity Oz.
	U +0.000 -0.001	V	Sq.	Lgth.			
133	0.625	1.88	0.187	1.18	A	16.5	8
175	0.750	2.00	0.187	1.31	A ₁	18.5	9
200	0.875	2.44	0.187	1.75	A ₁	25	11
225	1.000	2.69	0.250	1.88	A ₁	28	15
258	1.125	2.63	0.250	1.88	A ₁	45	32
300	1.250	3.00	0.250	2.25	A, B, C	49	38
350	1.500	3.44	0.375	2.75	A, B, C,	75	51
400	1.625	3.75	0.375	2.75	A, B, C, D	98	80

Motor Information				
Worm Bore Size Designation	NEMA Design	Bore +0.002 -0.000	Key Way	R
A	56C	0.625	0.187 x 0.093	3.25
B	180C/140TC	0.875	0.187 x 0.093	3.25
C	180TC/210C	1.125	0.250 x 0.125	4.50
D	210TC	1.375	0.312 x 0.156	4.50

Assembly Types
Side View

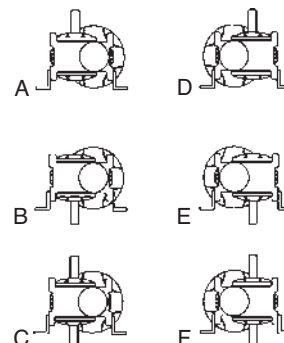

H50 Reducer

900 Series Single Reduction

900 Series Double Reduction

Accessories

Ratio Multipliers

In-Line Helical (LH)

Universal Series Single Reduction

Universal Series Double Reduction

Engineering

Style ST



Universal Series Dimensions Single Reduction Solid Worm Type

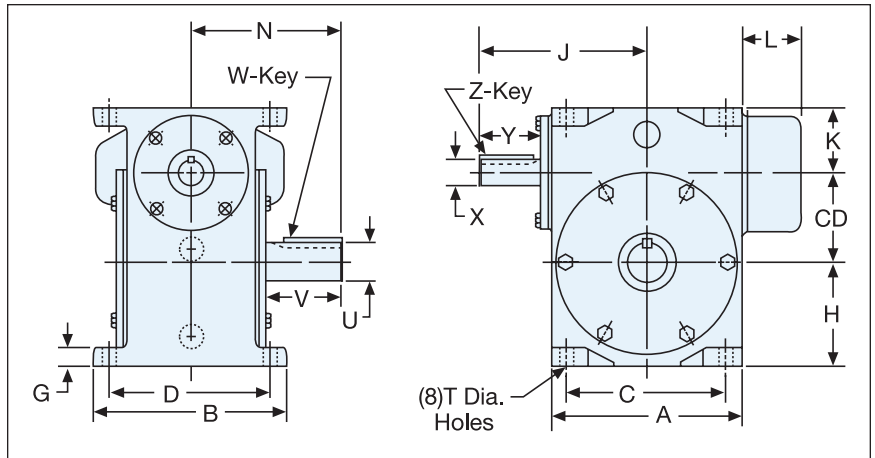

Size	C.D.	A	B	C	D	G	H	J	K	L Fan Cooled	N	T
133	1.33	4.25	4.38	3.50	3.63	0.50	2.00	4.63	1.88	—	4.13	0.343
175	1.75	4.25	4.38	3.50	3.63	0.50	2.38	4.63	1.88	—	4.25	0.343
200	2.00	5.25	5.00	4.25	4.13	0.63	2.69	5.38	2.06	—	4.88	0.406
225	2.25	5.25	5.00	4.25	4.13	0.63	2.94	5.38	2.06	—	5.13	0.406
258	2.63	7.00	6.25	5.63	5.13	0.75	3.25	6.50	2.38	—	5.50	0.531
300	3.00	7.00	6.25	5.63	5.13	0.75	3.63	6.50	2.38	—	5.88	0.531
350	3.50	7.63	7.63	6.38	6.38	0.88	4.13	7.16	2.63	2.13	6.50	0.531
400	4.00	8.63	8.63	7.38	7.38	0.88	4.50	7.69	3.00	2.13	7.38	0.531
500	5.00	11.75	11.88	9.13	10.00	1.13	6.13	11.03	4.38	3.38	9.75	0.781
600	6.00	13.25	12.88	11.00	11.00	1.25	6.75	11.94	4.50	3.38	10.63	0.906

Size	Output Shaft				Input Shaft				Approximate Weight Lbs.	Approximate Oil Capacity Oz.
	U +0.000 -0.001	V	W-Key		X +0.000 -0.001	Y	Z-Key			
			Sq.	Lgth.			Sq.	Lgth.		
133	0.625	1.88	0.187	1.18	0.500	1.88	0.125	1.38	12.5	5
175	0.750	2.00	0.187	1.31	0.625	1.88	0.187	1.38	14.5	6
200	0.875	2.44	0.187	1.75	0.625	2.13	0.187	1.50	20	10
225	1.000	2.69	0.250	1.88	0.750	2.13	0.187	1.50	22	14
258	1.125	2.63	0.250	1.88	0.750	2.38	0.187	1.88	36	32
300	1.250	3.00	0.250	2.25	0.875	2.38	0.187	1.88	40	40
350	1.500	3.44	0.375	2.75	1.000	2.66	0.250	2.25	66	51
400	1.625	3.75	0.375	2.75	1.125	2.69	0.250	2.50	91	80
500	2.000	3.81	0.500	2.50	1.500	3.97	0.375	3.25	315	211
600	2.250	4.44	0.500	3.38	1.500	4.16	0.375	3.50	375	256

Assembly Types Side View

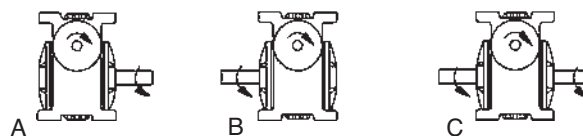

Style SB

Universal Series Dimensions Single Reduction Solid Worm Type

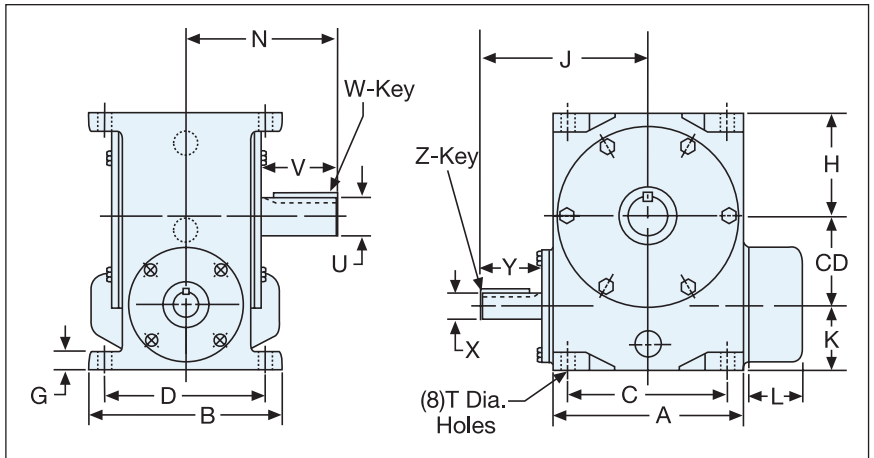

Size	C.D.	A	B	C	D	G	H	J	K	L Fan Cooled	N	T
133	1.33	4.25	4.38	3.50	3.63	0.50	2.00	4.63	1.88	—	4.13	0.343
175	1.75	4.25	4.38	3.50	3.63	0.50	2.38	4.63	1.88	—	4.25	0.343
200	2.00	5.25	5.00	4.25	4.13	0.63	2.69	5.38	2.06	—	4.88	0.406
225	2.25	5.25	5.00	4.25	4.13	0.63	2.94	5.38	2.06	—	5.13	0.406
258	2.63	7.00	6.25	5.63	5.13	0.75	3.25	6.50	2.38	—	5.50	0.531
300	3.00	7.00	6.25	5.63	5.13	0.75	3.63	6.50	2.38	—	5.88	0.531
350	3.50	7.63	7.63	6.38	6.38	0.88	4.13	7.16	2.63	2.13	6.50	0.531
400	4.00	8.63	8.63	7.38	7.38	0.88	4.50	7.69	3.00	2.13	7.38	0.531
500	5.00	11.75	11.88	9.13	10.00	1.13	6.13	11.03	4.38	3.38	9.75	0.781
600	6.00	13.25	12.88	11.00	11.00	1.25	6.75	11.94	4.50	3.38	10.63	0.906

Size	Output Shaft				Input Shaft				Approximate Weight Lbs.	Approximate Oil Capacity Oz.
	U +0.000 -0.001	V	W-Key		X +0.000 -0.001	Y	Z-Key			
			Sq.	Lgth.			Sq.	Lgth.		
133	0.625	1.88	0.187	1.18	0.500	1.88	0.125	1.38	12.5	10
175	0.750	2.00	0.187	1.31	0.625	1.88	0.187	1.38	14.5	10
200	0.875	2.44	0.187	1.75	0.625	2.13	0.187	1.50	20	12
225	1.000	2.69	0.250	1.88	0.750	2.13	0.187	1.50	22	14
258	1.125	2.63	0.250	1.88	0.750	2.38	0.187	1.88	36	32
300	1.250	3.00	0.250	2.25	0.875	2.38	0.187	1.88	40	40
350	1.500	3.44	0.375	2.75	1.000	2.66	0.250	2.25	66	51
400	1.625	3.75	0.375	2.75	1.125	2.69	0.250	2.50	91	80
500	2.000	3.81	0.500	2.50	1.500	3.97	0.375	3.25	315	211
600	2.250	4.44	0.500	3.38	1.500	4.16	0.375	3.50	375	256

Assembly Types Side View

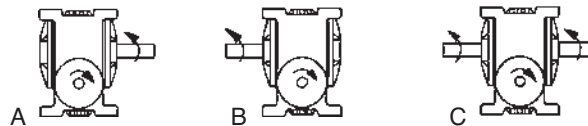

H50 Reducer
900 Series Single Reduction
900 Series Double Reduction
Accessories
Ratio Multipliers
In-Line Helical (LH)
Universal Series Single Reduction
Universal Series Double Reduction
Engineering

Style SV

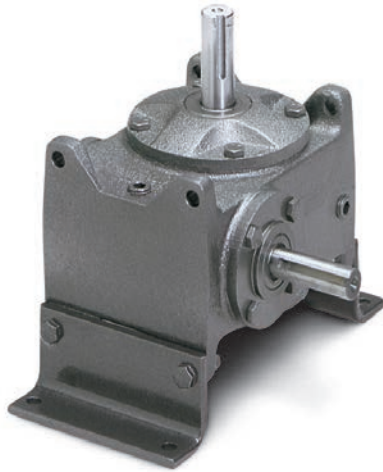

Universal Series Dimensions Single Reduction Solid Worm Type

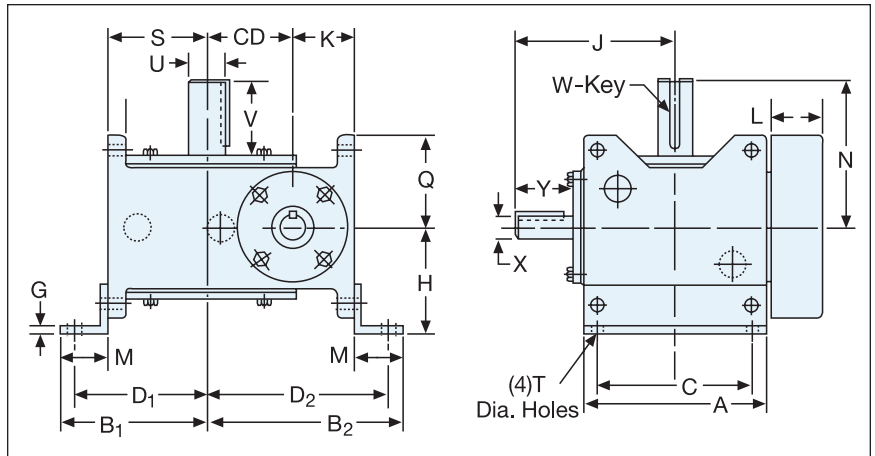

Size	C.D.	A	B1	B2	C	D1	D2	G	H	J	K	L Fan Guard	M	N	Q	S	T
133	1.33	4.25	4.47	3.97	3.50	2.88	3.97	0.25	3.38	4.63	1.88	—	1.25	4.13	2.188	2.00	0.343
175	1.75	4.25	3.63	4.88	3.50	3.25	4.50	0.25	3.38	4.63	1.88	—	1.25	4.25	2.188	2.38	0.406
200	2.00	5.25	4.19	5.56	4.25	3.75	5.13	0.25	3.38	5.38	2.06	—	1.56	4.88	2.500	2.69	0.406
225	2.25	5.25	4.44	5.81	4.25	4.00	5.38	0.25	3.38	5.38	2.06	—	1.56	5.13	2.500	2.94	0.406
258	2.63	7.00	5.25	7.00	5.63	4.75	6.50	0.25	3.38	6.50	2.38	—	2.00	5.50	3.125	3.25	0.531
300	3.00	7.00	5.63	7.38	5.63	5.13	6.88	0.25	3.38	6.50	2.38	—	2.00	5.88	3.125	3.63	0.531
350	3.50	7.63	6.13	8.13	6.38	5.50	7.50	0.25	4.56	7.16	2.63	2.13	2.00	6.50	3.813	4.13	0.531
400	4.00	8.63	6.50	9.00	7.38	5.88	8.38	0.25	5.06	7.69	3.00	2.13	2.00	7.38	5.313	4.50	0.531
500	5.00	11.75	9.63	12.88	9.13	8.13	11.38	0.50	7.00	11.03	4.38	3.38	3.50	9.75	5.313	6.13	0.781
600	6.00	13.25	10.75	14.50	11.00	9.19	12.94	0.50	7.94	11.94	4.50	3.38	4.00	10.63	6.438	6.75	0.906

Size	Output Shaft				Input Shaft				Approximate Weight Lbs.	Approximate Oil Capacity Oz.
	U +0.000 -0.001	V	W-Key		X +0.000 -0.001	Y	Z-Key			
			Sq.	Lgth.			Sq.	Lgth.		
133	0.625	1.88	0.187	1.18	0.500	1.88	0.125	1.38	13.5	8
175	0.750	2.00	0.187	1.31	0.625	1.88	0.187	1.38	15.5	9
200	0.875	2.44	0.187	1.75	0.625	2.13	0.187	1.50	21	11
225	1.000	2.69	0.250	1.88	0.750	2.13	0.187	1.50	23	15
258	1.125	2.63	0.250	1.88	0.750	2.38	0.187	1.88	38	32
300	1.250	3.00	0.250	2.25	0.875	2.38	0.187	1.88	42	38
350	1.500	3.44	0.375	2.75	1.000	2.66	0.250	2.25	68	51
400	1.625	3.75	0.375	2.75	1.125	2.69	0.250	2.50	93	80
500	2.000	3.81	0.500	2.50	1.500	3.97	0.375	3.25	319	211
600	2.250	4.44	0.500	3.38	1.500	4.16	0.375	3.50	379	256

Assembly Types

Side View

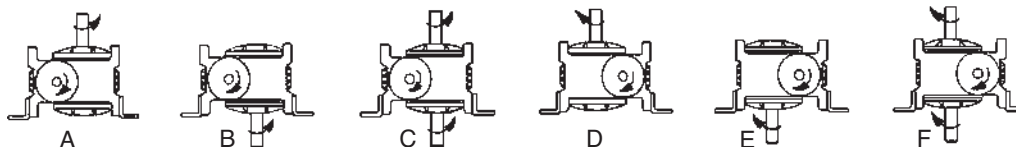

Style STL

Universal Series Dimensions Single Reduction Flanged Coupling Type

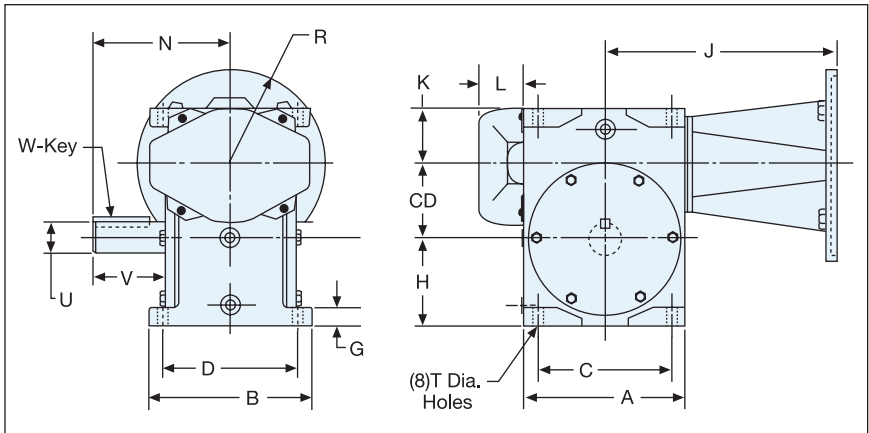
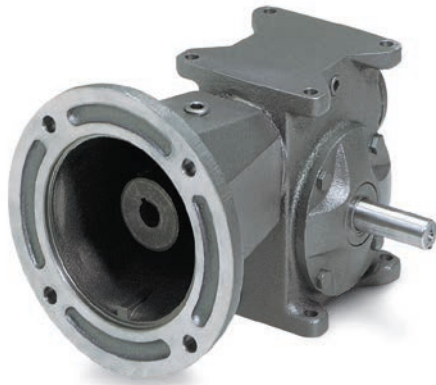

Size	C.D.	A	B	C	D	G	H	R					J					K	L	N	T	
								56C 140TC	180TC 210C	210TC	250TC	280TC	56C 140TC	180TC 210C	210TC	250TC	280TC					
133	1.33	4.25	4.38	3.50	3.63	0.50	2.00	3.25	—	—	—	—	7.25	—	—	—	—	1.88	—	4.13	0.343	
175	1.75	4.25	4.38	3.50	3.63	0.50	2.38	3.25	3.25	—	—	—	8.03	—	—	—	—	1.88	—	4.25	0.343	
200	2.00	5.25	5.00	4.25	4.13	0.63	2.69	3.25	3.25	—	—	—	8.03	—	—	—	—	2.06	—	4.88	0.406	
225	2.25	5.25	5.00	4.25	4.13	0.63	2.94	3.25	—	—	—	—	8.03	—	—	—	—	2.06	—	5.13	0.406	
258	2.63	7.00	6.25	5.63	5.13	0.75	3.25	3.25	4.50	—	—	—	9.38	10.19	—	—	—	2.38	—	5.50	0.531	
300	3.00	7.00	6.25	5.63	5.13	0.75	3.63	3.25	4.50	—	—	—	9.38	10.19	—	—	—	2.38	—	5.88	0.531	
350	3.50	7.63	7.63	6.38	6.38	0.88	4.13	3.25	4.50	—	—	—	9.78	11.22	—	—	—	2.63	2.13	6.50	0.531	
400	4.00	8.63	8.63	7.38	7.38	0.88	4.50	3.25	4.50	4.50	—	—	10.31	11.75	11.75	—	—	3.00	2.13	7.38	0.531	
500	5.00	11.75	11.88	9.13	10.00	1.13	6.13	—	4.56	4.56	4.56	—	—	15.81	15.81	15.81	—	—	4.38	3.38	9.75	0.781
600	6.00	13.25	12.88	11.00	11.00	1.25	6.75	—	4.50	4.50	4.50	5.56	—	16.69	16.69	16.69	17.56	—	—	10.63	0.906	

Size	Output Shaft				Motor Size Available Per Size Any Ratio	Approximate Weight Lbs.	Approximate Oil Capacity Oz.
	U +0.000 -0.001	V	W-Key				
			Sq.	Lgth.			
133	0.625	1.88	0.187	1.18	A, B, C, D	19.5	256
175	0.750	2.00	0.187	1.31	A, B	21.5	6
200	0.875	2.44	0.187	1.75	A, B	28	10
225	1.000	2.69	0.250	1.88	A, B	31	14
258	1.125	2.63	0.250	1.88	A, B, C	46	32
300	1.250	3.00	0.250	2.25	A, B, C	51	40
350	1.500	3.44	0.375	2.75	A, B, C, D	79	51
400	1.625	3.75	0.375	2.75	A, B, C, D	100	80
500	2.000	3.75	0.500	3.81	C, D, E	360	211
600	2.250	4.44	0.500	3.38	C, D, E, F	420	256

Motor Information			
Coupling Bore Size Designation	NEMA Design	Bore +0.002 -0.000	Key Way
A	56C	0.625	0.187 x 0.093
B	140tC	0.875	0.187 x 0.093
C	180tc	1.125	0.250 x 0.125
D	210TC	1.375	0.187 x 0.156
E	250TC	1.625	0.375 x 0.187
F	280TC	1.875	0.500 x 0.250

Assembly Types End View

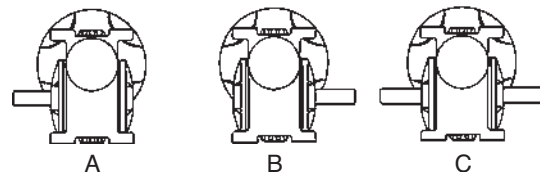

H50 Reducer
900 Series Single Reduction
900 Series Double Reduction
Accessories
Ratio Multipliers
In-Line Helical (LH)
Universal Series Single Reduction
Universal Series Double Reduction
Engineering

Style SVL

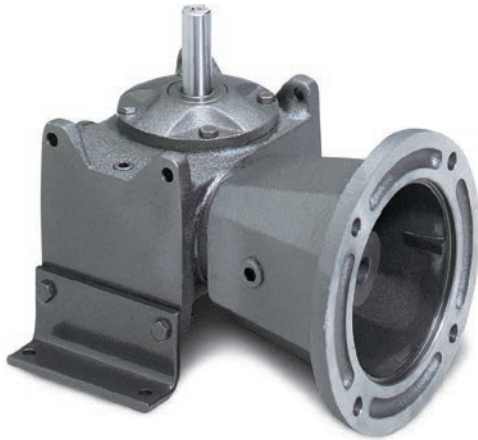

Universal Series Dimensions Single Reduction Flanged Coupling Type

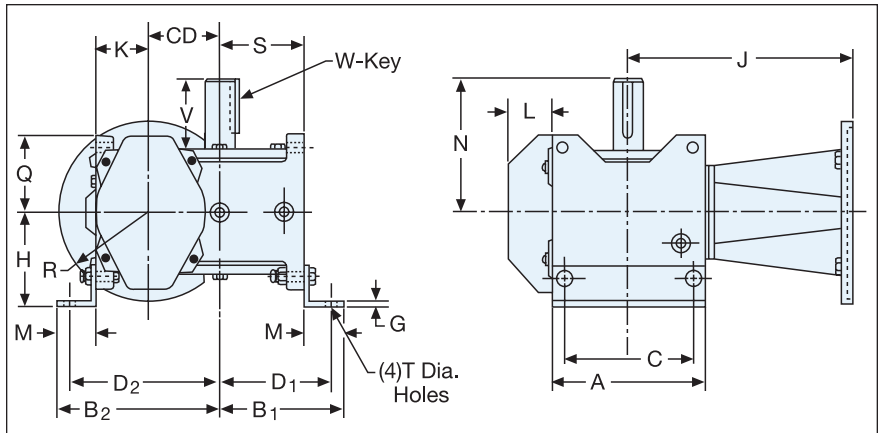

Size	C.D.	A	B1	B2	C	D1	D2	G	H						R						J						K	L
									Except 258C & 300C	258C & 300C ONLY	56C 140TC	180TC 210C	210TC	250TC	280TC	56C 140TC	180TC 210C	210TC	250TC	280TC	56C 140TC	180TC 210C	210TC	250TC	280TC			
133	1.33	4.25	3.31	4.53	3.50	2.88	4.09	0.25	3.38	—	3.25	—	—	—	—	—	7.25	—	—	—	—	1.88	—					
175	1.75	4.25	3.69	4.94	3.50	3.25	4.50	0.25	3.38	—	3.25	3.25	—	—	—	—	7.25	—	—	—	—	1.88	—					
200	2.00	5.25	4.25	5.63	4.25	3.75	5.13	0.25	3.38	—	3.25	3.25	—	—	—	—	8.03	—	—	—	—	2.06	—					
225	2.25	5.25	4.50	5.88	4.25	4.00	5.38	0.25	3.38	—	3.25	3.25	—	—	—	—	8.03	—	—	—	—	2.06	—					
258	2.63	7.00	5.31	7.06	5.63	4.75	6.50	0.25	3.38	5.38	3.25	4.50	—	—	—	—	9.38	10.19	—	—	—	2.38	—					
300	3.00	7.00	5.69	7.44	5.63	5.13	6.88	0.25	3.38	5.38	3.25	4.50	—	—	—	—	9.38	10.19	—	—	—	2.38	—					
350	3.50	7.63	6.13	8.13	6.38	5.50	7.50	0.25	4.56	—	3.25	4.50	—	—	—	—	10.31	11.75	11.75	—	—	2.63	2.13					
400	4.00	8.63	6.50	9.00	7.38	5.88	8.38	0.25	4.88	—	3.25	4.50	4.50	—	—	—	10.31	11.75	11.75	—	—	3.00	2.13					
500	5.00	11.75	9.63	12.88	9.13	8.13	11.38	0.50	7.00	—	—	4.56	4.56	4.56	—	—	15.81	15.81	15.81	—	—	4.38	3.38					
600	6.00	13.25	10.75	14.50	11.00	9.19	12.94	0.50	7.94	—	—	4.50	4.50	4.56	5.56	—	16.69	16.69	16.69	17.56	4.50	3.38						

Size	M	N	Q	S	T	Output Shaft				Motor Size Available Per Size Any Ratio	Approximate Weight Lbs.	Approximate Oil Capacity Oz.
						U +0.000 -0.001	V	W-Key				
							Sq.	Lgth.				
133	1.31	4.13	2.188	2.00	0.343	0.625	1.88	0.187	1.18	A	20.5	8
175	1.31	4.25	2.188	2.38	0.343	0.750	2.00	0.187	1.31	A, B	22.5	9
200	1.56	4.88	2.500	2.69	0.406	0.875	2.44	0.187	1.75	A, B	29	11
225	1.56	5.13	2.500	2.94	0.406	1.000	2.69	0.250	1.88	A, B	32	15
258	2.06	5.50	3.125	3.25	0.531	1.125	2.63	0.250	1.88	A, B, C	48	32
300	2.06	5.88	3.125	3.63	0.531	1.250	3.00	0.250	2.25	A, B, C	53	38
350	2.00	6.50	3.813	4.13	0.531	1.500	3.44	0.375	2.75	A, B, C, D	82	51
400	2.00	7.38	5.313	4.13	0.531	1.625	3.75	0.375	2.75	A, B, C, D	103	80
500	3.50	9.75	5.313	6.13	0.781	2.000	3.81	0.500	2.50	C, D, E	364	212
600	4.00	10.60	6.438	6.75	0.906	2.250	4.44	0.500	3.38	C, D, E, F	434	256

Motor Information			
Coupling Bore Size Designation	NEMA Design	Bore +0.002 -0.000	Key Way
A	56C	0.625	0.187 x 0.093
B	140TC	0.875	0.187 x 0.093
C	180TC	1.125	0.250 x 0.125
D	210TC	1.375	0.187 x 0.156
E	250TC	1.625	0.375 x 0.187
F	280TC	1.875	0.500 x 0.250

Assembly Types Side View

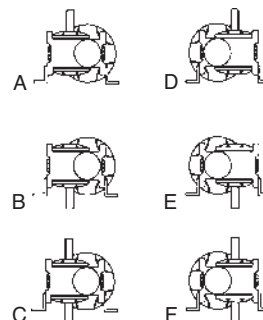

Accessories and Options



Optional Universal Series Vertical Bases

OPTIONAL UNIVERSAL SERIES VERTICAL BASES

Kit includes angle bases and hardware. Converts style STF to SVF.

Base Size	NEMA Frame	Catalog Number	Approx. Shipping Weight
133 - 175	56C / 140TC	B1317V81	1
200 - 225	56C / 140TC	B2022V81	1
258 - 300	56C / 140TC	B2530V81	1
258 - 300	180TC	B2530V91	1
350	56C / 140TC 180TC / 210TC	B3500V81	1

H50
Reducer

900 Series
Single Reduction

900 Series
Double Reduction

Accessories

Ratio Multipliers

In-Line Helical (LH)

Universal Series
Single Reduction

Universal Series
Double Reduction

Engineering

Universal Series Double Reduction

Style Reference Guide	164
How to Order	165
Ratings Tables	166
Dimensions	167 - 175



H50
Reducer

900 Series
Single Reduction

900 Series
Double Reduction

Accessories

Ratio Multiplier

In-Line Helical (LH)

Universal Series
Single Reduction

Universal Series
Double Reduction

Engineering

Universal Series Style Reference Guide

Double Reduction

DTF



Ratings P. 166
Dimensions P. 167

DBF

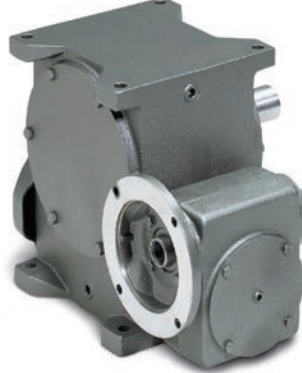

Ratings P. 166
Dimensions P. 168

DVF

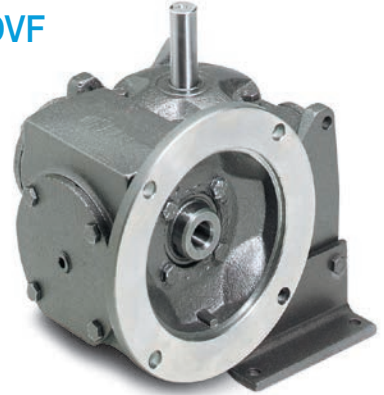

Ratings P. 166
Dimensions P. 169

DTL

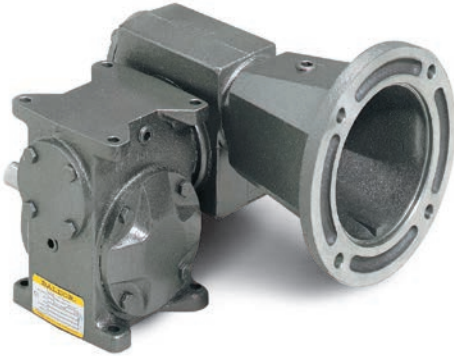

Ratings P. 166
Dimensions P. 170

DBL

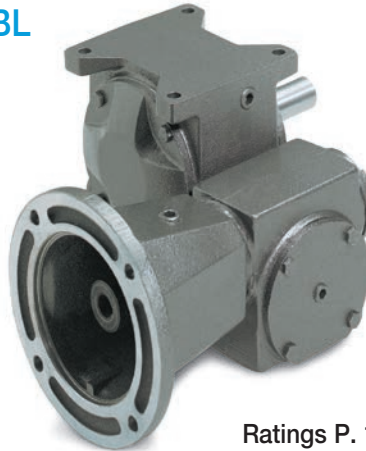

Ratings P. 166
Dimensions P. 171

DVL

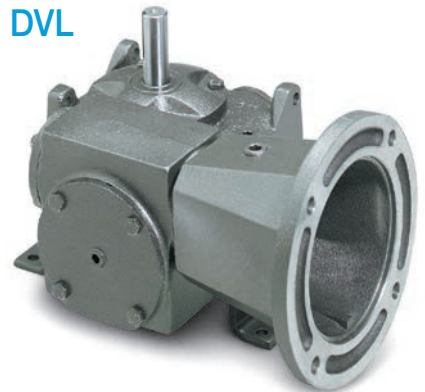

Ratings P. 166
Dimensions P. 172

WDT



Ratings P. 166
Dimensions P. 173

WDB



Ratings P. 166
Dimensions P. 174

WDV



Ratings P. 166
Dimensions P. 175

H50 Reducer

900 Series Single Reduction

900 Series Double Reduction

Accessories

Ratio Multipliers

In-Line Helical (LH)

Universal Series Single Reduction

Universal Series Double Reduction

Engineering

Universal Series Numbering System/How to Order

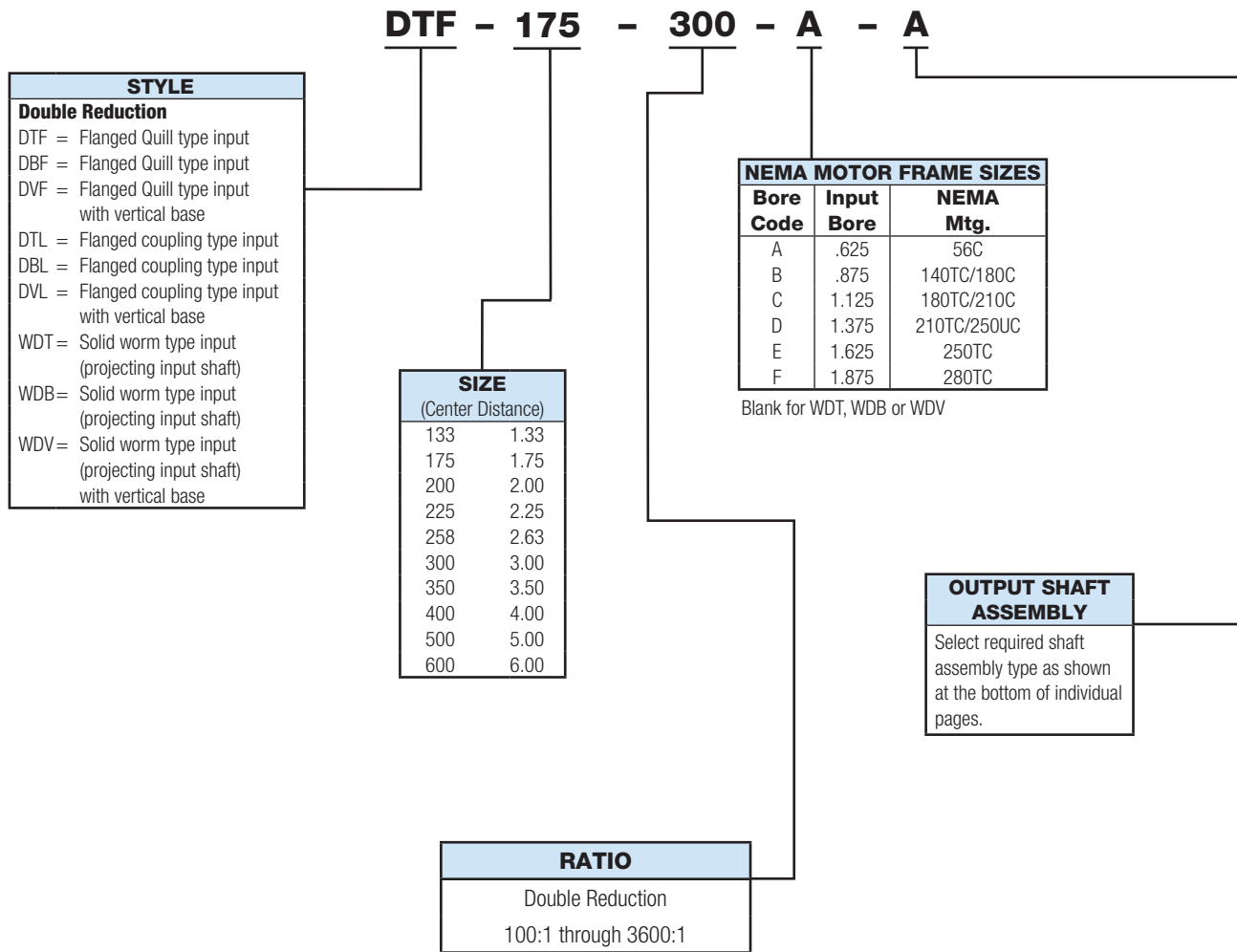

HOW TO ORDER

Please specify Style, Size, Base (if required), Ratio, NEMA Input Flange (if flanged reducer), Output shaft assembly.

EXAMPLE

Required size, 350, Quill type input, 600:1, 56C, horizontal output shaft

Order **DBF-350-600-A-A**

Universal Series Double Reduction Ratio and Capacity Selection Tables
Horsepower & Torque Ratings for Service Class I (1.0 Service Factor)

Ratio	Input RPM	Output RPM	Size 175			Size 200			Size 225			Size 258		
			Input Hp	Output Hp	Output Torque In. Lbs.	Input Hp	Output Hp	Output Torque In. Lbs.	Input Hp	Output Hp	Output Torque In. Lbs.	Input Hp	Output Hp	Output Torque In. Lbs.
100	1750	17.5	0.210	0.165	595	0.308	0.240	770	0.420	0.340	1207	0.620	0.500	1750
150	1750	11.6	0.160	0.125	630	0.225	0.180	945	0.340	0.270	1365	0.480	0.380	2047
200	1750	8.7	0.130	0.104	730	0.190	0.150	1050	0.265	0.210	1440	0.390	0.310	2180
300	1750	5.8	0.086	0.069	730	0.125	0.100	1050	0.175	0.140	1440	0.240	0.192	2180
400	1750	4.4	0.070	0.055	770	0.098	0.078	1100	0.142	0.110	1550	0.210	0.163	2300
500	1750	3.5	0.057	0.044	770	0.082	0.063	1100	0.112	0.086	1500	0.180	0.139	2300
600	1750	2.9	0.050	0.037	770	0.071	0.053	1100	0.098	0.074	1550	0.150	0.110	2300
900	1750	1.9	0.034	0.024	760	0.050	0.035	1100	0.080	0.056	1500	0.125	0.088	2250
1200	1750	1.5	0.028	0.018	760	0.042	0.027	1100	0.056	0.036	1500	0.090	0.058	2250
1800	1750	1.0	0.022	0.012	760	0.031	0.017	1100	0.040	0.024	1500	0.071	0.039	2250
2400	1750	0.73	0.018	0.009	705	0.024	0.012	1050	0.036	0.018	1530	0.048	0.024	2140
3600	1750	0.5	0.011	0.005	590	0.017	0.007	910	0.020	0.008	1250	0.037	0.015	1900
OVERHUNG LOAD*			INPUT SHAFT 155 LBS. OUTPUT SHAFT 460 LBS.			INPUT SHAFT 155 LBS. OUTPUT SHAFT 650 LBS.			INPUT SHAFT 155 LBS. OUTPUT SHAFT 870 LBS.			INPUT SHAFT 155 LBS. OUTPUT SHAFT 1200 LBS.		
OUTPUT SHAFT THRUST LOAD			400 LBS.			600 LBS.			750 LBS.			900 LBS.		

Ratio	Input RPM	Output RPM	Size 300			Size 350			Size 400			Size 500		
			Input Hp	Output Hp	Output Torque In. Lbs.	Input Hp	Output Hp	Output Torque In. Lbs.	Input Hp	Output Hp	Output Torque In. Lbs.	Input Hp	Output Hp	Output Torque In. Lbs.
100	1750	17.5	0.790	0.680	2275	1.640	1.214	4370	2.400	1.800	6480	4.210	2.160	11404
150	1750	11.6	0.640	0.510	2625	1.180	0.824	4475	1.830	1.283	6968	3.580	2.510	13686
200	1750	8.7	0.540	0.430	3050	0.940	0.632	4525	1.300	0.980	7015	3.070	2.090	14134
300	1750	5.8	0.370	0.290	3050	0.720	0.463	5029	1.050	0.670	7300	2.180	1.420	15470
400	1750	4.4	0.310	0.240	3250	0.600	0.356	5100	0.880	0.524	7500	1.830	1.100	15737
450	1750	3.9	0.250	0.187	3230	0.530	0.309	5125	0.800	0.464	7700	1.650	0.959	15505
600	1750	2.9	0.230	0.158	3230	0.440	0.237	5150	0.650	0.356	7750	1.340	0.736	15990
900	1750	1.9	0.150	0.105	3150	0.310	0.154	5120	0.480	0.238	7900	0.980	0.491	16285
1200	1750	1.5	0.125	0.080	3150	0.270	0.113	5090	0.420	0.175	7760	0.860	0.363	15242
1800	1750	1.0	0.096	0.053	3150	0.210	0.074	4800	0.330	0.114	7450	0.680	0.238	14989
2400	1750	0.73	0.072	0.037	3080	0.195	0.058	4500	0.310	0.092	7090	0.540	0.163	14106
3600	1750	0.5	0.050	0.020	2500	0.145	0.036	4700	0.219	0.053	6950	0.390	0.099	12580
OVERHUNG LOAD*			INPUT SHAFT 155 LBS. OUTPUT SHAFT 1575 LBS.			INPUT SHAFT 225 LBS. OUTPUT SHAFT 1695 LBS.			INPUT SHAFT 225 LBS. OUTPUT SHAFT 1950 LBS.			INPUT SHAFT 414 LBS. OUTPUT SHAFT 2880 LBS.		
OUTPUT SHAFT THRUST LOAD			1100 LBS.			1200 LBS.			1700 LBS.			2100 LBS.		

Ratio	Input RPM	Output RPM	Size 600		
			Input Hp	Output Hp	Output Torque In. Lbs.
100	1750	17.5	4.840	3.630	13068
150	1750	11.6	4.400	3.080	16727
200	1750	8.7	4.390	2.990	21528
300	1750	5.8	3.070	2.000	21810
400	1750	4.4	2.550	1.530	22105
500	1750	3.5	2.340	1.360	22135
600	1750	2.9	1.890	1.040	22612
900	1750	1.9	1.370	0.680	22300
1200	1750	1.5	1.210	0.510	21970
1800	1750	1.0	0.880	0.310	20406
2400	1750	0.73	0.780	0.230	20316
3600	1750	0.5	0.620	0.150	20086
OVERHUNG LOAD*			INPUT SHAFT 414 LBS. OUTPUT SHAFT 3880 LBS.		
OUTPUT SHAFT THRUST LOAD			2500 LBS.		

*Overhung Load Rating is at center of shaft extension with no thrust load.

Style DTF

Worm Gear Speed Reducers Double Reduction with Motor Flange

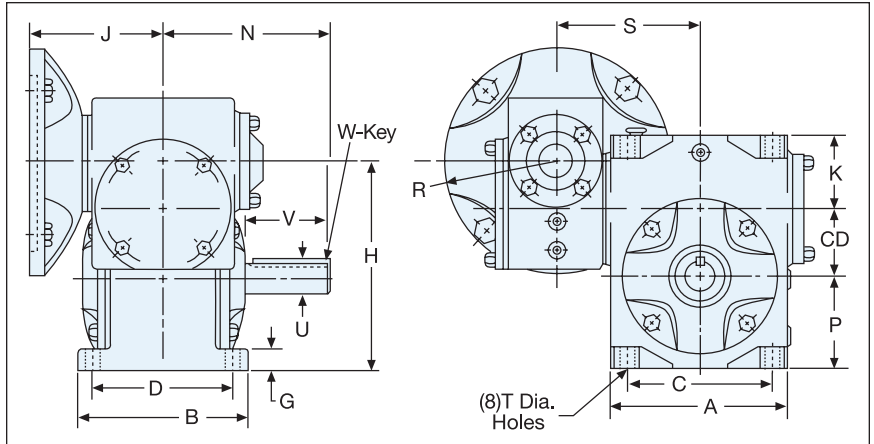

Size	C.D.	A	B	C	D	G	H	J	K	N	P	S	T
175	1.75	4.25	4.38	3.50	3.63	0.50	5.46	3.88	1.88	4.25	2.38	3.75	0.343
200	2.00	5.25	5.00	4.25	4.13	0.63	6.02	3.88	2.06	4.88	2.69	4.25	0.406
225	2.25	5.25	5.00	4.25	4.13	0.63	6.52	3.88	2.06	5.13	2.94	4.25	0.406

Size	Output Shaft				Motor Size Available Per Size and Ratio												Approx. Weight lbs.	Approx. Oil Capacity oz.
	U +0.000 -0.001	V	W-Key		100:1	150:1	200:1	300:1	400:1	500:1	600:1	900:1	1200:1	1800:1	2400:1	3600:1		
			Sq.	Lgth.														
175	0.750	2.00	0.187	1.31	A	A	A	A	A	A	A	A	A	A	A	A	27	16
200	0.875	2.44	0.187	1.75	A	A	A	A	A	A	A	A	A	A	A	A	31.5	16
225	1.000	2.69	0.250	1.88	A	A	A	A	A	A	A	A	A	A	A	A	34	20

Motor Information				
Worm Bore Size Designation	NEMA Design	Bore +0.002 -0.000	Key Way	R
A	56C	0.625	0.187 x 0.093	3.25

Assembly Types

Top View

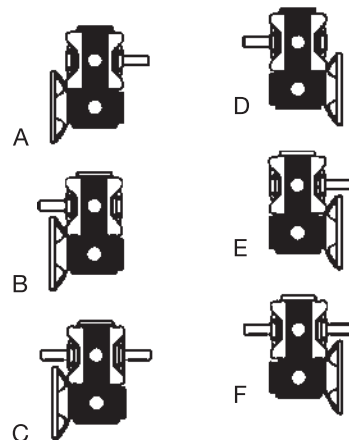

Style DBF

Worm Gear Speed Reducers
Double Reduction with Motor Flange

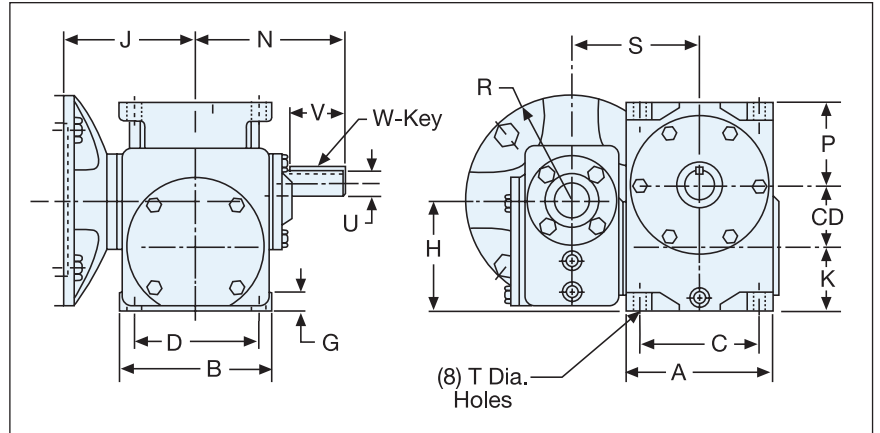
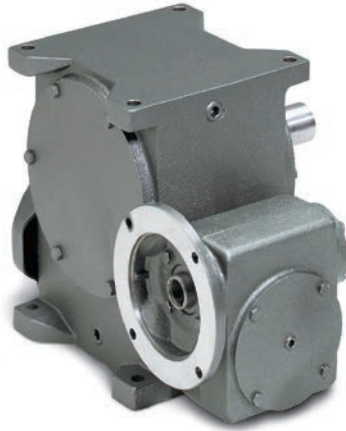

Size	C.D.	A	B	C	D	G	H	J		K	N	P	S	T
								56C 140TC	180TC 210C					
175	1.75	4.25	4.38	3.50	3.63	0.50	3.21	3.88	—	1.88	4.25	2.38	3.75	0.343
200	2.00	5.25	5.00	4.25	4.13	0.63	3.40	3.88	—	2.06	4.88	2.69	4.25	0.406
225	2.25	5.25	5.00	4.25	4.13	0.63	3.40	3.88	—	2.06	5.13	2.94	4.25	0.406
258	2.63	7.00	6.25	5.63	5.13	0.75	4.13	3.88	—	2.38	5.50	3.25	5.13	0.531
300	3.00	7.00	6.25	5.63	5.13	0.75	4.13	3.88	—	2.38	5.88	3.63	5.13	0.531
350	3.50	7.63	7.63	6.38	6.38	0.88	4.63	4.38	—	2.63	6.50	4.13	5.59	0.531
400	4.00	8.63	8.63	7.38	7.38	0.88	5.25	4.38	—	3.00	7.38	4.50	6.38	0.531
500	5.00	11.75	11.88	9.13	10.00	1.13	7.38	5.00	6.06	4.38	9.75	6.13	9.81	0.781
600	6.00	13.25	12.88	11.00	11.00	1.25	7.50	5.00	6.06	4.50	10.63	6.75	10.56	0.906

Size	Output Shaft				Motor Size Available Per Size and Ratio													Appr. Wgt. lbs.	Appr. Oil Cap. oz.
	U +0.000 -0.001	V	W-Key		100:1	150:1	200:1	300:1	400:1	450:1	500:1	600:1	900:1	1200:1	1800:1	2400:1	3600:1		
			Sq.	Lgth.															
175	0.750	2.00	0.187	1.31	A	A	A	A	A	—	A	A	A	A	A	A	A	34.0	16
200	0.875	2.44	0.187	1.75	A	A	A	A	A	—	A	A	A	A	A	A	A	39.5	18
225	1.000	2.69	0.250	1.88	A	A	A	A	A	—	A	A	A	A	A	A	A	42.0	20
258	1.125	2.63	0.250	1.88	A, B	A, B	A	A	A	—	A	A	A	A	A	A	A	57.5	39
300	1.250	3.00	0.250	2.25	A, B	A, B	A	A	A	—	A	A	A	A	A	A	A	64.3	47
350	1.500	3.44	0.375	2.75	A, B	A, B	A, B	A	A	A	—	A	A	A	A	A	A	99.0	61
400	1.625	3.75	0.375	2.75	A, B	A, B	A, B	A, B	A, B	A, B	—	A	A	A	A	A	A	124.0	94
500	2.000	3.81	0.500	2.50	B, C	B, C	B, C	B	B	B	—	B	A, B	A, B	A, B	A	A	437.0	282
600	2.250	4.44	0.500	3.38	B, C	B, C	B, C	B, C	B, C	A, B	—	A, B	A, B	A, B	A, B	A, B	A, B	492.0	327

Assembly Types
Top View

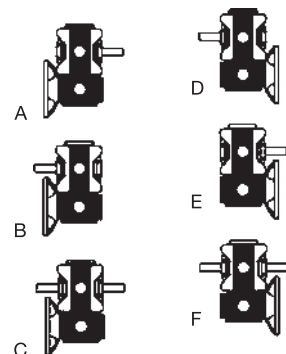

Motor Information				
Worm Bore Size Designation	NEMA Design	Bore +0.002 -0.000	Key Way	R
A	56C	0.625	0.187 x 0.937	3.25
B	140TC/180C	0.875	0.187 x 0.937	3.25
C	180TC/210C	1.125	0.250 x 0.125	4.50

H50 Reducer

900 Series Single Reduction

900 Series Double Reduction

Accessories

Ratio Multipliers

In-Line Helical (LH)

Universal Series Single Reduction

Universal Series Double Reduction

Engineering

Style DVF

Worm Gear Speed Reducers Double Reduction with Motor Flange

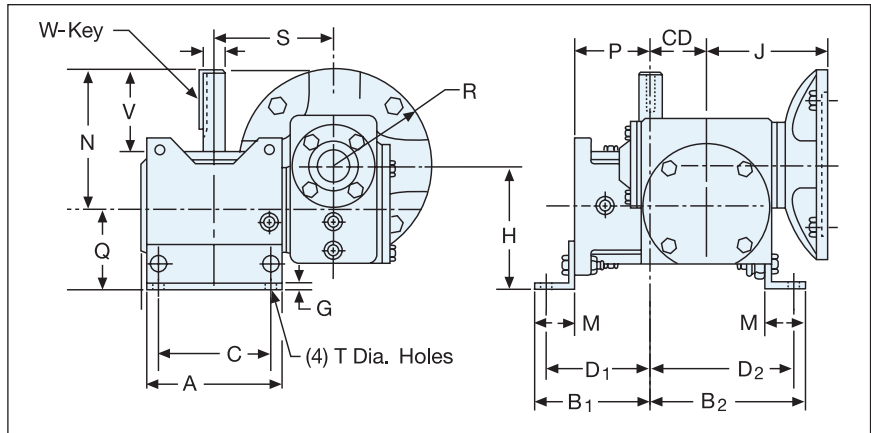
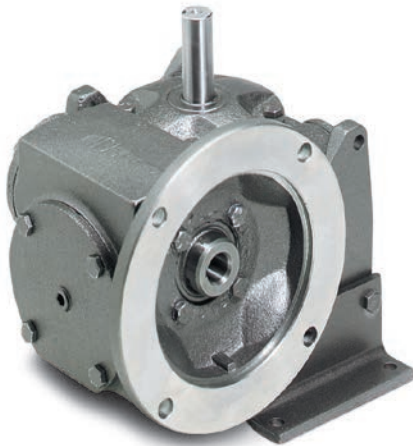

Size	C.D.	A	B1	B2	C	D1	D2	G	H	J		M	N	Q	S	T
										56C 140TC	180TC 210C					
175	1.75	4.25	3.63	5.63	3.50	3.25	4.50	0.25	4.71	3.88	—	1.25	4.25	3.38	3.75	0.343
200	2.00	5.25	4.19	5.88	4.25	3.75	5.13	0.25	4.71	3.88	—	1.50	4.88	3.38	4.25	0.406
225	2.25	5.25	4.44	5.81	4.25	4.00	5.38	0.25	4.71	3.88	—	1.50	5.13	3.38	4.25	0.406
258	2.63	7.00	5.25	7.00	5.63	4.75	6.50	0.25	5.13	3.88	—	2.00	5.50	3.38	5.13	0.531
300	3.00	7.00	5.63	7.38	5.63	5.13	6.88	0.25	5.13	3.88	—	2.00	5.88	3.38	5.13	0.531
350	3.50	7.63	6.13	8.13	6.38	5.50	7.50	0.25	6.56	4.38	—	2.00	6.50	4.56	5.59	0.531
400	4.00	8.63	6.50	9.00	7.38	5.88	8.38	0.25	7.31	4.38	—	2.00	7.38	5.06	6.38	0.531
500	5.00	11.75	9.63	12.88	9.13	8.13	11.38	0.50	10.00	5.00	6.06	3.50	9.75	7.00	9.44	0.781
600	6.00	13.25	10.75	14.50	11.00	9.19	12.94	0.50	10.94	5.00	6.06	4.00	10.63	7.94	10.56	0.906

Size	Output Shaft				Motor Size Available Per Size And Ratio														Appr. Wgt. Lbs.	Appr. Oil Cap. Oz.
	U +0.000 -0.001	V	W-Key		100:1	150:1	200:1	300:1	400:1	450:1	500:1	600:1	900:1	1200:1	1800:1	2400:1	3600:1			
			Sq.	Lgth.																
175	0.750	2.00	0.187	1.31	A	A	A	A	A	—	A	A	A	A	A	A	A	28.0	16	
200	0.875	2.44	0.187	1.75	A	A	A	A	A	—	A	A	A	A	A	A	A	32.5	17	
225	1.000	2.69	0.250	1.88	A	A	A	A	A	—	A	A	A	A	A	A	A	35.0	21	
258	1.125	2.63	0.250	1.88	A, B	A, B	A	A	A	—	A	A	A	A	A	A	A	49.3	39	
300	1.250	3.00	0.250	2.25	A, B	A, B	A	A	A	—	A	A	A	A	A	A	A	56.0	47	
350	1.500	3.44	0.375	2.75	A, B	A, B	A, B	A	A	A	—	A	A	A	A	A	A	87.0	61	
400	1.625	3.75	0.375	2.75	A, B	A, B	A, B	A, B	A, B	A, B	—	A	A	A	A	A	A	112.0	94	
500	2.000	3.81	0.500	2.50	B, C	B, C	B, C	B	B	B	—	B	A, B	A, B	A, B	A	A	431.0	282	
600	2.250	4.44	0.500	3.38	B, C	B, C	B, C	A, B	B, C	A, B	—	A, B	A, B	A, B	A, B	A, B	A, B	486.0	327	

Motor Information				
Worm Bore Size Designation	NEMA Design	Bore +0.002 -0.000	Key Way	R
A	56C	0.625	0.187 x 0.093	3.25
B	140TC/180C	0.875	0.187 x 0.093	3.25
C	180TC/210C	1.125	0.250 x 0.125	4.50

Assembly Types Side View

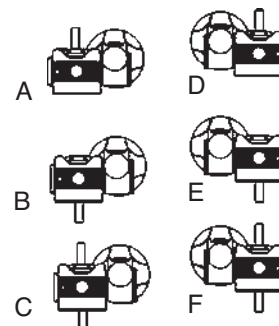

Style DTL

**Worm Gear Speed Reducers
Double Reduction with Motor Flange**

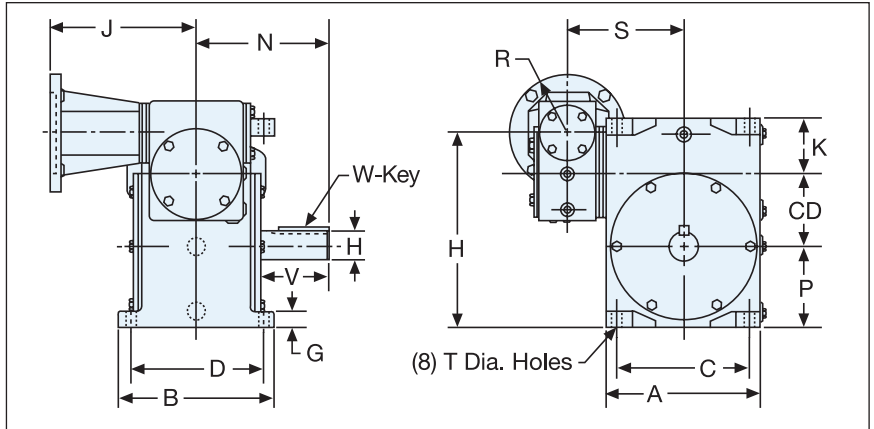
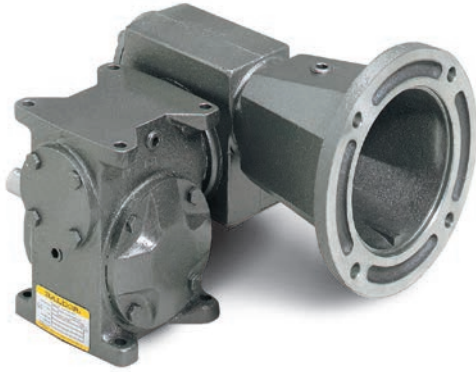

Size	C.D.	A	B	C	D	G	H	J		K	N	P	S	T
								56C 140TC	180TC 210C					
175	1.75	4.25	4.38	3.50	3.63	0.50	5.46	7.25	—	1.88	4.25	2.38	3.75	0.343
200	2.00	5.25	5.00	4.25	4.13	0.63	6.02	7.25	—	2.06	4.88	2.69	4.25	0.406
225	2.25	5.25	5.00	4.25	4.13	0.63	6.52	7.25	—	2.06	5.13	2.94	4.25	0.406
258	2.63	7.00	6.25	5.63	5.13	0.75	7.63	7.25	—	2.38	5.50	3.25	5.13	0.531
300	3.00	7.00	6.25	5.63	5.13	0.75	8.38	7.25	—	2.38	5.88	3.63	5.13	0.531
350	3.50	7.63	7.63	6.38	6.38	0.88	9.63	8.03	—	2.63	6.50	4.13	5.59	0.531
400	4.00	8.63	8.63	7.38	7.38	0.88	10.75	8.03	—	3.00	7.38	4.50	6.38	0.531
500	5.00	11.75	11.88	9.13	10.00	1.13	14.13	9.38	10.19	4.38	9.75	6.13	9.81	0.781
600	6.00	13.25	12.88	11.00	11.00	1.25	15.75	9.38	10.19	4.50	10.63	6.75	10.56	0.906

Size	Output Shaft				Motor Size Available Per Size And Ratio														Appr. Wgt. Lbs.	Appr. Oil Cap. Oz.
	U +0.000 -0.001	V	W-Key		100:1	150:1	200:1	300:1	400:1	450:1	500:1	600:1	900:1	1200:1	1800:1	2400:1	3600:1			
			Sq.	Lgth.																
175	0.750	2.00	0.187	1.31	A	A	A	A	A	—	A	A	A	A	A	A	A	34.0	16	
200	0.875	2.44	0.187	1.75	A	A	A	A	A	—	A	A	A	A	A	A	A	39.5	16	
225	1.000	2.69	0.250	1.88	A	A	A	A	A	—	A	A	A	A	A	A	A	42.0	20	
258	1.125	2.63	0.250	1.88	A, B	A, B	A	A	A	—	A	A	A	A	A	A	A	57.5	39	
300	1.250	3.00	0.250	2.25	A, B	A, B	A	A	A	—	A	A	A	A	A	A	A	64.3	47	
350	1.500	3.44	0.375	2.75	A, B	A, B	A, B	A	A	A	—	A	A	A	A	A	A	99.0	61	
400	1.625	3.75	0.375	2.75	A, B	A, B	A, B	A, B	A, B	A, B	—	A	A	A	A	A	A	124.0	94	
500	2.000	3.81	0.500	2.50	C	B, C	B, C	B, C	A, B	A, B	—	A, B	A, B	A, B	A, B	A	A	437.0	282	
600	2.250	4.44	0.500	3.38	C	B, C	B, C	B, C	B, C	B, C	—	A, B	A, B	A, B	A, B	A, B	A, B	492.0	327	

Assembly Types
Top View

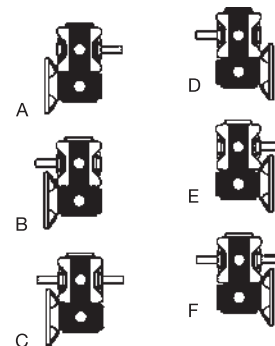

Motor Information				
Worm Bore Size Designation	NEMA Design	Bore +0.002 -0.000	Key Way	R
A	56C	0.625	0.187 x 0.093	3.25
B	140TC/180C	0.875	0.187 x 0.093	3.25
C	180TC/210C	1.125	0.250 x 0.125	4.50

H50 Reducer

900 Series Single Reduction

900 Series Double Reduction

Accessories

Ratio Multipliers

In-Line Helical (LH)

Universal Series Single Reduction

Universal Series Double Reduction

Engineering

Style DBL

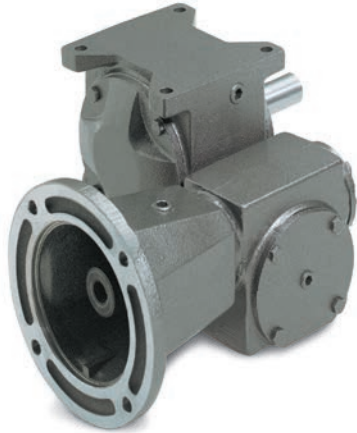

Worm Gear Speed Reducers Double Reduction with Motor Flange

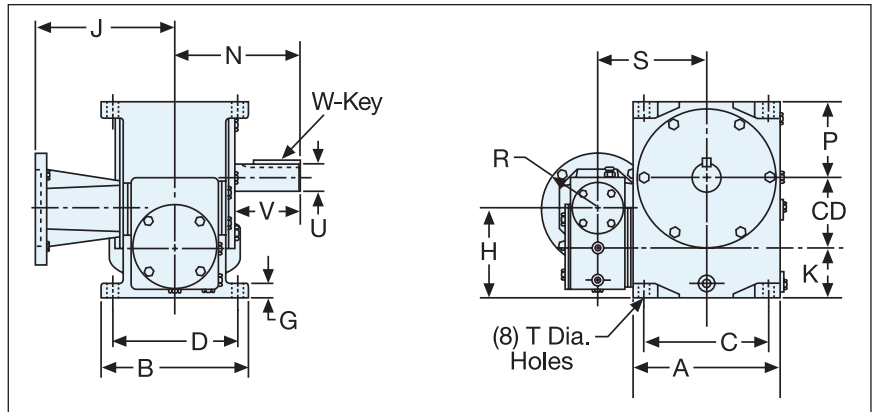

Size	C.D.	A	B	C	D	G	H	J		K	N	P	S	T
								56C 140TC	180TC 210C					
175	1.75	4.25	4.38	3.50	3.63	0.50	3.21	7.25	—	1.88	4.25	2.38	3.75	0.343
200	2.00	5.25	5.00	4.25	4.13	0.63	3.40	7.25	—	2.06	4.88	2.69	4.25	0.406
225	2.25	5.25	5.00	4.25	4.13	0.63	3.40	7.25	—	2.06	5.13	2.94	4.25	0.406
258	2.63	7.00	6.25	5.63	5.13	0.75	4.13	7.25	—	2.38	5.50	3.25	5.13	0.531
300	3.00	7.00	6.25	5.63	5.13	0.75	4.13	7.25	—	2.38	5.88	3.63	5.13	0.531
350	3.50	7.63	7.63	6.38	6.38	0.88	4.63	8.03	—	2.63	6.50	4.13	5.59	0.531
400	4.00	8.63	8.63	7.38	7.38	0.88	5.25	8.03	—	3.00	7.38	4.50	6.38	0.531
500	5.00	11.75	11.88	9.13	10.00	1.13	7.38	9.38	10.19	4.38	9.75	6.13	9.81	0.781
600	6.00	13.25	12.88	11.00	11.00	1.25	7.50	9.38	10.19	4.50	10.63	6.75	10.56	0.906

Size	Output Shaft				Motor Size Available Per Size And Ratio													Appr. Wgt. Lbs.	Appr. Oil Cap. Oz.
	U +0.000 -0.001	V	W-Key		100:1	150:1	200:1	300:1	400:1	450:1	500:1	600:1	900:1	1200:1	1800:1	2400:1	3600:1		
			Sq.	Lgth.															
175	0.750	2.00	0.187	1.31	A	A	A	A	A	—	A	A	A	A	A	A	A	34.0	16
200	0.875	2.44	0.187	1.75	A	A	A	A	A	—	A	A	A	A	A	A	A	39.5	18
225	1.000	2.69	0.250	1.88	A	A	A	A	A	—	A	A	A	A	A	A	A	42.0	20
258	1.125	2.63	0.250	1.88	A, B	A, B	A	A	A	—	A	A	A	A	A	A	A	57.5	39
300	1.250	3.00	0.250	2.25	A, B	A, B	A	A	A	—	A	A	A	A	A	A	A	64.3	47
350	1.500	3.44	0.375	2.75	A, B	A, B	A, B	A	A	A	—	A	A	A	A	A	A	99.0	61
400	1.625	3.75	0.375	2.75	A, B	A, B	A, B	A, B	A, B	A, B	—	A	A	A	A	A	A	124.0	94
500	2.000	3.81	0.500	2.50	C	B, C	B, C	B, C	A, B	A, B	—	A, B	A, B	A, B	A, B	A	A	437.0	282
600	2.250	4.44	0.500	3.38	C	B, C	B, C	B, C	B, C	B, C	—	A, B	A, B	A, B	A, B	A, B	A, B	492.0	327

Assembly Types Top View

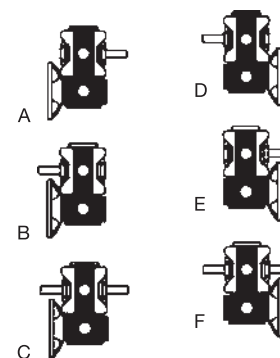

Motor Information				
Worm Bore Size Designation	NEMA Design	Bore +0.002 -0.000	Key Way	R
A	56C	0.625	0.187 x 0.093	3.25
B	140TC/180C	0.875	0.187 x 0.093	3.25
C	180TC/210C	1.125	0.250 x 0.125	4.50

Style DVL

Worm Gear Speed Reducers Double Reduction with Motor Flange

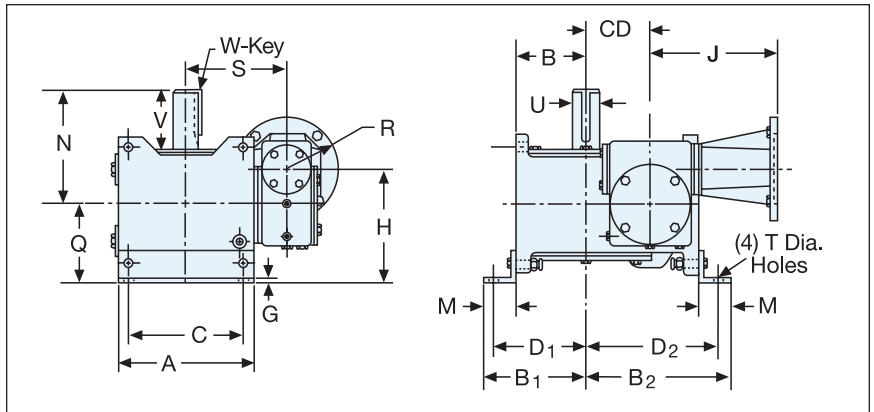
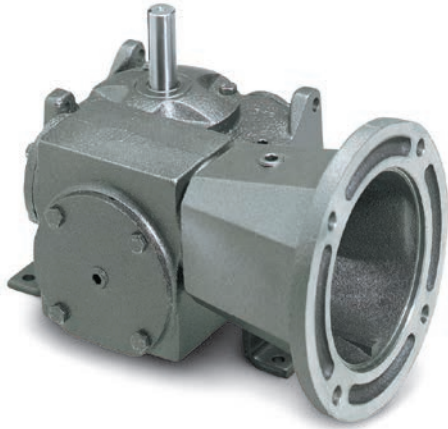

Size	C.D.	A	B1	B2	C	D1	D2	G	H	J		M	N	Q	S	T
										56C 140TC	180TC 210C					
175	1.75	4.25	3.63	5.63	3.50	3.25	4.50	0.25	4.71	7.25	—	1.25	4.25	3.38	3.75	0.343
200	2.00	5.25	4.19	5.88	4.25	3.75	5.13	0.25	4.71	7.25	—	1.50	4.88	3.38	4.25	0.406
225	2.25	5.25	4.44	5.81	4.25	4.00	5.38	0.25	4.71	7.25	—	1.50	5.13	3.38	4.25	0.406
258	2.63	7.00	5.25	7.00	5.63	4.75	6.50	0.25	5.13	7.25	—	2.00	5.50	3.38	5.13	0.531
300	3.00	7.00	5.63	7.38	5.63	5.13	6.88	0.25	5.13	7.25	—	2.00	5.88	3.38	5.13	0.531
350	3.50	7.63	6.13	8.13	6.38	5.50	7.50	0.25	6.56	8.03	—	2.00	6.50	4.56	5.59	0.531
400	4.00	8.63	6.50	9.00	7.38	5.88	8.38	0.25	7.13	8.03	—	2.00	7.38	4.88	6.38	0.531
500	5.00	11.75	9.63	12.88	9.13	8.13	11.38	0.50	10.00	9.38	10.19	3.50	9.75	7.00	9.44	0.781
600	6.00	13.25	10.75	14.50	11.00	9.19	12.94	0.50	10.94	9.38	10.19	4.00	10.63	7.94	10.56	0.906

Size	Output Shaft				Motor Size Available Per Size And Ratio														Appr Wgt Lbs.	Appr. Oil Cap. Oz.
	U +0.000 -0.001	V	W-Key		100:1	150:1	200:1	300:1	400:1	450:1	500:1	600:1	900:1	1200:1	1800:1	2400:1	3600:1			
			Sq.	Lgth.																
175	0.750	2.00	0.187	1.31	A	A	A	A	A	—	A	A	A	A	A	A	A	35.0	16	
200	0.875	2.44	0.187	1.75	A	A	A	A	A	—	A	A	A	A	A	A	A	40.5	17	
225	1.000	2.69	0.250	1.88	A	A	A	A	A	—	A	A	A	A	A	A	A	43.0	21	
258	1.125	2.63	0.250	1.88	A, B	A, B	A	A	A	—	A	A	A	A	A	A	A	59.5	39	
300	1.250	3.00	0.250	2.25	A, B	A, B	A	A	A	—	A	A	A	A	A	A	A	66.3	47	
350	1.500	3.44	0.375	2.75	A, B	A, B	A, B	A	A	A	—	A	A	A	A	A	A	101.0	61	
400	1.625	3.75	0.375	2.75	A, B	A, B	A, B	A, B	A, B	A, B	—	A	A	A	A	A	A	126.0	94	
500	2.000	3.81	0.500	2.50	C	B, C	B, C	B, C	A, B	A, B	—	A, B	A, B	A, B	A, B	A	A	441.0	282	
600	2.250	4.44	0.500	3.38	C	B, C	B, C	B, C	B, C	B, C	—	A, B	A, B	A, B	A, B	A, B	A, B	496.0	327	

Motor Information				
Worm Bore Size Designation	NEMA Design	Bore +0.002 -0.000	Key Way	R
A	56C	0.625	0.187 x 0.093	3.25
B	140TC/180C	0.875	0.187 x 0.093	3.25
C	180TC/210C	1.125	0.025 x 0.125	4.50

Assembly Types Side View

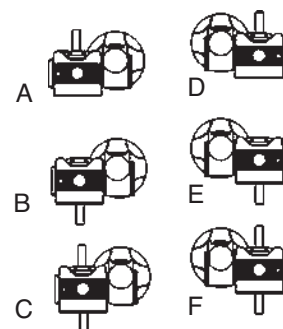

H50 Reducer

900 Series Single Reduction

900 Series Double Reduction

Accessories

Ratio Multipliers

In-Line Helical (LH)

Universal Series Single Reduction

Universal Series Double Reduction

Engineering

Style WDT

Universal Series Dimensions Double Reduction Solid Worm Type

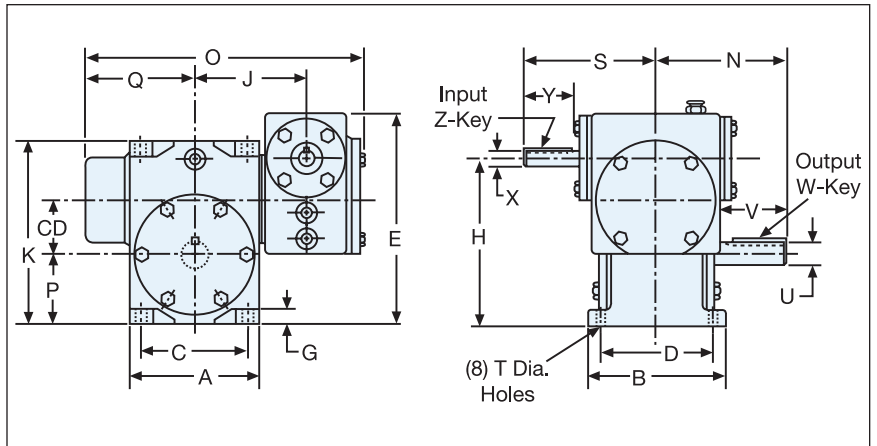
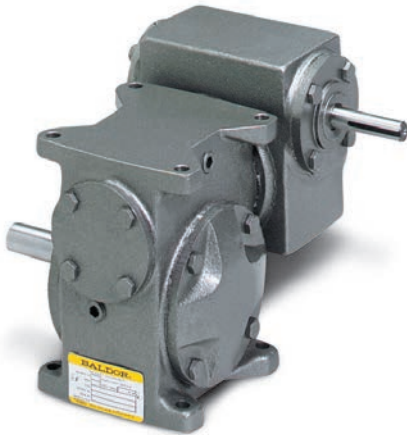

Size	C.D.	A	B	C	D	E	G	H	J	K	N	O	P	Q	S	T
175	1.75	4.25	4.38	3.50	3.63	7.00	0.50	5.46	3.75	6.00	4.25	8.44	2.38	2.75	4.63	0.343
200	2.00	5.25	5.00	4.25	4.13	7.56	0.63	6.02	4.25	6.75	4.88	9.44	2.69	3.25	4.63	0.406
225	2.25	5.25	5.00	4.25	4.13	8.06	0.63	6.52	4.25	7.25	5.13	9.44	2.94	3.25	4.63	0.406
258	2.63	7.00	6.25	5.63	5.13	9.13	0.75	7.63	5.13	8.25	5.50	11.19	3.25	4.13	4.63	0.531
300	3.00	7.00	6.25	5.63	5.13	9.88	0.75	8.38	5.13	9.00	5.88	11.19	3.63	4.13	4.63	0.531
350	3.50	7.63	7.63	6.38	6.38	11.31	0.88	9.63	5.59	10.25	6.50	13.94	4.13	6.13	5.38	0.531
400	4.00	8.63	8.63	7.38	7.38	12.44	0.88	10.75	6.38	11.50	7.38	15.13	4.50	6.69	5.38	0.531
500	5.00	11.75	11.88	9.13	10.00	16.56	1.13	14.13	9.81	15.50	9.75	21.69	6.13	9.25	6.50	0.781
600	6.00	13.25	12.88	11.00	11.00	18.19	1.25	15.75	10.56	17.25	10.63	23.19	6.75	10.00	6.50	0.906

Size	Output Shaft				Input Shaft				Approx. Weight lbs.	Approx. Oil Capacity oz.
	U +0.000 -0.001	V	W-Key		X +0.000 -0.001	Y	Z-Key			
			Sq.	Lgth.			Sq.	Lgth.		
175	0.750	2.00	0.187	1.31	0.500	2.13	0.125	1.38	24	12
200	0.875	2.44	0.187	1.75	0.500	2.38	0.125	1.38	28	16
225	1.000	2.69	0.250	1.88	0.500	2.38	0.125	1.38	31	20
258	1.125	2.63	0.250	1.88	0.625	2.63	0.187	1.38	45	39
300	1.250	3.00	0.250	2.25	0.625	2.63	0.187	1.38	48	47
350	1.500	3.44	0.375	2.75	0.625	2.97	0.187	1.50	79	61
400	1.625	3.75	0.375	2.75	0.750	3.00	0.187	1.50	103	94
500	2.000	3.81	0.500	2.50	0.875	4.31	0.187	1.88	375	282
600	2.250	4.44	0.500	3.38	0.875	4.50	0.187	1.88	435	327

Assembly Types Top View

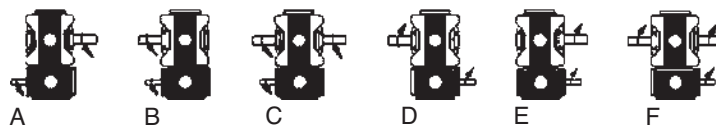

Style WDB

Universal Series Dimensions
Double Reduction Solid Worm Type

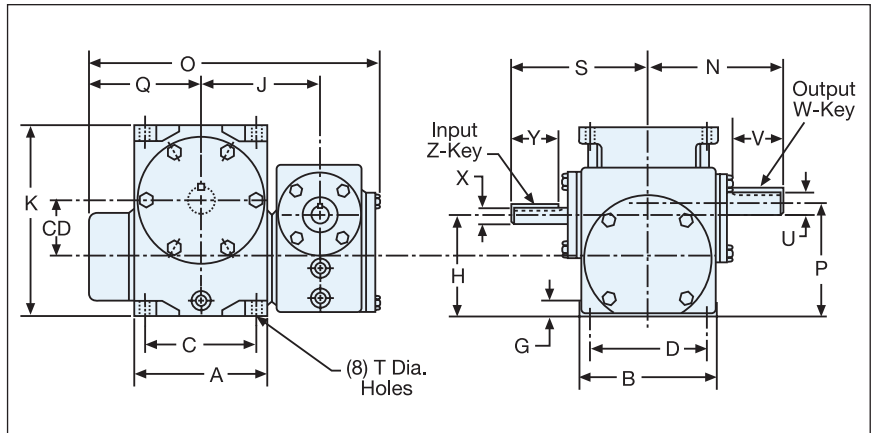

Size	C.D.	A	B	C	D	G	H	J	K	N	O	P	Q	S	T
175	1.75	4.25	4.38	3.50	3.63	0.50	3.21	3.75	6.00	4.25	8.44	3.63	2.75	4.63	0.343
200	2.00	5.25	5.00	4.25	4.13	0.63	3.40	4.25	6.75	4.88	9.44	4.06	3.25	4.63	0.406
225	2.25	5.25	5.00	4.25	4.13	0.63	3.40	4.25	7.25	5.13	9.44	4.31	3.25	4.63	0.406
258	2.63	7.00	6.25	5.63	5.13	0.75	4.13	5.13	8.25	5.50	11.19	5.00	4.13	4.63	0.531
300	3.00	7.00	6.25	5.63	5.13	0.75	4.13	5.13	9.00	5.88	11.19	5.38	4.13	4.63	0.531
350	3.50	7.63	7.63	6.38	6.38	0.88	4.63	5.59	10.25	6.50	13.94	6.13	6.13	5.38	0.531
400	4.00	8.63	8.63	7.38	7.38	0.88	5.25	6.38	11.50	7.38	15.13	7.00	6.69	5.38	0.531
500	5.00	11.75	11.88	9.13	10.00	1.13	7.38	9.81	15.50	9.75	21.69	9.38	9.25	6.50	0.781
600	6.00	13.25	12.88	11.00	11.00	1.25	7.50	10.56	17.25	10.63	23.19	10.50	10.00	6.50	0.906

Size	Output Shaft				Input Shaft				Approx. Weight lbs.	Approx. Oil Capacity oz.
	U +0.000 -0.001	V	W-Key		X +0.000 -0.001	Y	Z-Key			
			Sq.	Lgth.			Sq.	Lgth.		
175	0.750	2.00	0.187	1.31	0.500	2.13	0.125	1.38	24	16
200	0.875	2.44	0.187	1.75	0.500	2.38	0.125	1.38	28	18
225	1.000	2.69	0.250	1.88	0.500	2.38	0.125	1.38	31	20
258	1.125	2.63	0.250	1.88	0.625	2.63	0.187	1.38	45	39
300	1.250	3.00	0.250	2.25	0.625	2.63	0.187	1.38	48	47
350	1.500	3.44	0.375	2.75	0.625	2.97	0.187	1.50	79	61
400	1.625	3.75	0.375	2.75	0.750	3.00	0.187	1.50	103	94
500	2.000	3.81	0.500	2.50	0.875	4.31	0.187	1.88	375	282
600	2.250	4.44	0.500	3.38	0.875	4.50	0.187	1.88	435	327

Assembly Types
Top View

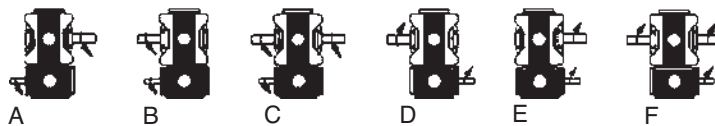

H50 Reducer

900 Series Single Reduction

900 Series Double Reduction

Accessories

Ratio Multipliers

In-Line Helical (LH)

Universal Series Single Reduction

Universal Series Double Reduction

Engineering

Style WDV

Universal Series Dimensions Double Reduction Solid Worm Type

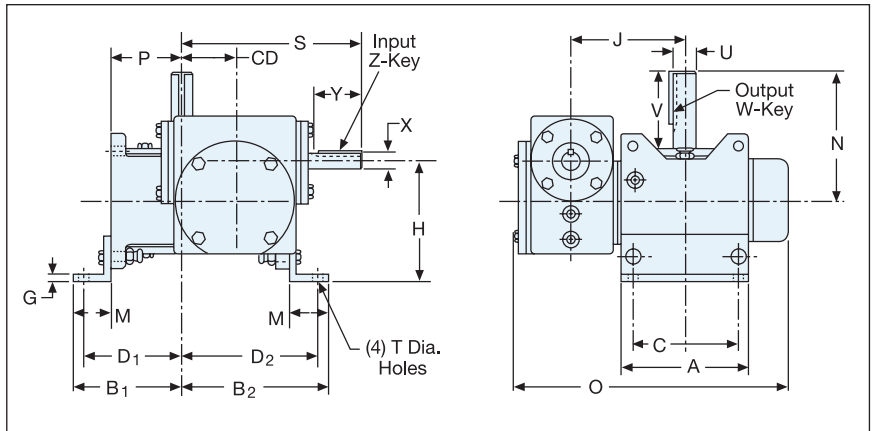
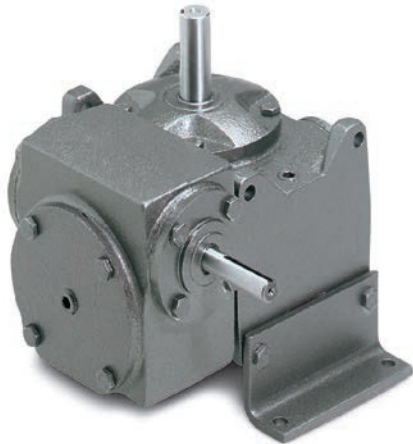

Size	C.D.	A	B1	B2	C	D1	D2	G	H	J	N	O	P	S	T
175	1.75	4.25	3.63	4.88	3.50	3.25	4.50	0.25	4.71	3.75	4.25	8.44	2.38	6.38	0.343
200	2.00	5.25	4.19	5.56	4.25	3.75	5.13	0.25	4.71	4.25	4.88	9.44	2.69	6.63	0.406
225	2.25	5.25	4.44	5.81	4.25	4.00	5.38	0.25	4.71	4.25	5.13	9.44	2.94	6.88	0.406
258	2.63	7.00	5.25	7.00	5.63	4.75	6.50	0.25	5.13	5.13	5.50	11.19	3.25	7.25	0.531
300	3.00	7.00	5.56	7.31	5.63	5.13	6.88	0.25	5.13	5.13	5.88	11.19	3.63	7.63	0.531
350	3.50	7.63	6.50	8.50	6.38	5.50	7.50	0.25	6.56	5.59	6.50	13.94	4.13	8.88	0.531
400	4.00	8.63	6.50	9.00	7.38	5.88	8.38	0.25	7.31	6.38	7.38	15.13	4.50	9.38	0.531
500	5.00	11.75	9.63	12.88	9.13	8.13	11.38	0.50	10.00	9.81	9.75	21.69	6.13	11.50	0.781
600	6.00	13.25	10.75	14.50	11.00	9.19	12.94	0.50	10.94	10.56	10.63	23.19	6.75	12.50	0.906

Size	Output Shaft				Input Shaft				Approx. Weight Lbs.	Approx. Oil Capacity Oz.
	U +0.000 -0.001	V	W-Key		X +0.000 -0.001	Y	Z-Key			
			Sq.	Lgth.			Sq.	Lgth.		
175	0.750	2.00	0.187	1.31	0.500	2.13	0.125	1.38	25	15
200	0.875	2.44	0.187	1.75	0.500	2.38	0.125	1.38	29	17
225	1.000	2.69	0.250	1.88	0.500	2.38	0.125	1.38	32	21
258	1.125	2.63	0.250	1.88	0.625	2.63	0.187	1.38	47	39
300	1.250	3.00	0.250	2.25	0.625	2.63	0.187	1.38	50	47
350	1.500	3.44	0.375	2.75	0.625	2.97	0.187	1.50	81	61
400	1.625	3.75	0.375	2.75	0.750	3.00	0.187	1.50	105	94
500	2.000	3.81	0.500	2.50	0.875	4.31	0.187	1.88	379	282
600	2.250	4.44	0.500	3.38	0.875	4.50	0.187	1.88	439	327

Assembly Types Side View

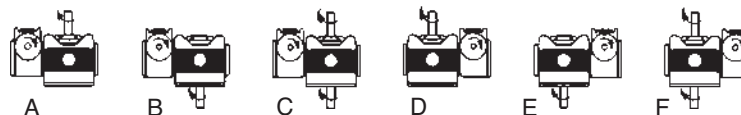

Engineering

H50 Reducer	Nomenclature	177 - 178
900 Series Single Reduction	Formulae and Constants	179
900 Series Double Reduction	AGMA Service Factors and Load Classifications	180 - 182
	Installation, Maintenance Instructions	183 - 188
900 Series Double Reduction	900, Universal and Ratio Multiplier Replacement Part Identification	189 - 197
	Seal and Coupling Kits	198 - 199
	Warranty	200
Accessories	Rotary Inertia and Torque Conversion Table	201
Ratio Multipliers		
In-Line Helical (LH)		
Universal Series Single Reduction		
Universal Series Double Reduction		
Engineering		

Engineering Information

Speed Reducer Nomenclature

AGMA

The American Gear Manufacturers Association (AGMA) is composed of member companies who manufacture speed reducers, enclosed gear drives, open gearing, and gear type shaft couplings, and an equally large number of technical members (domestic and foreign) who use these products or supply tools, machines, or other products to the gear industry. Together, they establish standards to help standardize the design and application of gear products. The work done by AGMA over the years has greatly advanced the quality and standardization of gearing. The combined experience of company members and technical members assures gear users that products built, selected, and applied in accordance with AGMA standards will perform well.

AXIAL MOVEMENT

Endwise movement of input or output shafts, sometimes called endplay, is usually expressed in thousands of an inch.

BACK-DRIVING

This is the converse of self-locking. Depending upon ratio and many variables, it is difficult to predict the back-driving capability. Worm gear reducers are not intended to be used as speed increasers. Consult factory for back-driving applications.

BACKLASH

Rotational movement of the output shaft when holding the input shaft stationary and rotating the output shaft alternately clockwise and counter clockwise. Backlash may be expressed in thousands of an inch measured at a specific radius at the output shaft.

CENTER DISTANCE

The distance between the center lines of the input and output shafts. The center distance of multiple stage reducers usually refers to the lowest speed stage (last reduction).

EFFICIENCY

Efficiency is the ratio of output power to input power. It is usually stated as a percentage.

Example:

$$\text{Input HP} = 2$$

$$\text{Output HP} = 1.6$$

$$(1.6 \div 2) \times 100 = 80\% \text{ Efficiency}$$

INPUT HORSEPOWER

The amount of power applied to the input shaft of a reducer by the prime mover is its input horsepower. It is often used as a selection basis for power transmission components, and it appears in the rating tables of drive manufacturer's published data. Remember that input horsepower ratings represent the maximum amount of power that the reducer can safely handle.

OUTPUT HORSEPOWER

The amount of power available at the output shaft of a reducer is its output horsepower. Due to losses caused by inefficiency, output horsepower is always less than input horsepower.

MECHANICAL RATING

The maximum power or torque that a speed reducer can transmit, based on the strength and durability of its components, is its mechanical rating. Obviously, the reducer may be rated no higher than the strength or durability of its weakest component. Reducers typically have a safety margin of two to three on their mechanical ratings. Thus, a reducer can withstand momentary overloads of 200-300% of its mechanical rating during a startup or other brief overload situation.

MOUNTING POSITION

The relationship of the input and output shafts relative to the floor line is the mounting position.

OVERHUNG LOAD

The input or the output shaft of a speed reducer can be subject of an overhung load; that is, to a force applied at right angles to the shaft, beyond its outermost bearing. Such a force is a shaft bending load resulting from a gear, pulley, sprocket or other external drive member. Besides the tendency to bend the shaft, the overhung load (that is, the radial force on the shaft) is reacted to by the shaft in its bearings. Therefore, the overhung load creates loads that the bearings must be able to support without damage.

PRIME MOVER

The machine that provides power to a drive is its prime mover. The most frequently encountered prime movers include electric motors, internal combustion engines, hydraulic motors and air motors. The type of prime mover used can affect the speed reducer during operation. For example, an electric motor runs relatively smoothly in comparison to an internal combustion engine.

Engineering Information

Speed Reducer Nomenclature (cont.)

H50
Reducer

900 Series
Single Reduction

900 Series
Double Reduction

Accessories

Ratio Multipliers

In-Line Helical (LH)

Universal Series
Single Reduction

Universal Series
Double Reduction

Engineering

RATIO

The ratio of a drive is based on the relationship of its input shaft speed to its output shaft speed. It is commonly expressed as a proportion.

SELF-LOCKING ABILITY

Self-locking ability is the ability to hold a load at rest. Baldor does not guarantee its worm reducers to be self locking. A brake or other device should be used to hold the load.

SERVICE FACTORS

Numbers which modify the loads which must be considered in selecting a speed reducer are called service factors. They vary with the type of service in which the reducer is to be used, the kind of prime mover involved and the duty cycle. The service factor can be a multiplier applied to the known load, which redefines the load in accordance with the conditions at which the drive will be used. Or it can be a divisor applied to catalog reducer ratings, thus redefining the rating in accordance with drive conditions. The service factor is usually applied to the speed reducer, but can also be applied to the nameplate rating of the prime mover.

THERMAL RATING

The maximum horsepower or torque that a speed reducer can transmit continuously, based on its ability to dissipate heat generated by friction, is called its thermal rating.

THRUST LOAD

Force imposed on a shaft parallel to the shaft axis is called a thrust load. It is often encountered on shafts driving mixers, fans, blowers and similar machines. When a thrust load acts on a speed reducer, you must be sure that the thrust load rating of the reducer is high enough that its shafts and bearings can absorb the load.

TORQUE

A twisting effort exerted around an axis is called torque. It is the product of a force and its distance from the axis around which the force acts.

Engineering Information Formulae and Constants

Torque (In.-Lbs.) = Force (Lbs.) x Radius (In.)

Torque (In.-Lbs.) = $\frac{63025 \times \text{HP}}{\text{RPM}}$

Torque (Ft.-Lbs.) = $\frac{5252 \times \text{HP}}{\text{RPM}}$

HP (Linear) x $\frac{\text{Lbs. (Force or Tension) x FPM}}{33,000}$

HP (Rotational) = $\frac{\text{Torque (Ft.-Lbs.) x RPM}}{5252}$

HP (Rotational) = $\frac{\text{Torque (In.-Lbs.) x RPM}}{63,025}$

HP (Pumps) = $\frac{\text{GPM x Head (Ft.) x Specific Gravity}}{3960 \times \text{Eff.}}$

HP (Fans) = $\frac{\text{CFM x Pressure (Lb./Sq. Ft.)}}{33,000 \times \text{Eff.}}$

Working Load or Chain Pull = $\frac{33,000 \times \text{Design HP}}{\text{Chain Speed (FPM)}}$

Working Load or Chain Pull = $\frac{\text{Design HP x } 396,000}{\text{Chain Pitch (In.) x No. of Teeth x RPM}}$

Overhung Load (Lbs.) = $\frac{126,000 \times \text{HP x K}}{\text{Pitch Dia. (In.) x RPM}}$

Where K =
 1.00 Chain
 1.25 Gears
 1.50 V-Belts
 2.50 Flat Belts
 3.50 Variable Speed Belts

Surface FPM = Diameter (Ft.) x 3.14 x RPM

Efficiency = $\frac{\text{Output HP}}{\text{Input HP}} \times 100$

Ratio = $\frac{\text{Input Speed}}{\text{Output Speed}}$

GENERAL INFORMATION (Approximation)

All Values At 100% Load	At 1800 rpm, a motor develops 36 lb.-in. per HP
	At 1200 rpm, a motor develops 54 lb.-in. per HP
	At 575 volts, a 3-phase motor draws 1 amp per HP
	At 460 volts, a 3-phase motor draws 1.25 amp per HP
	At 230 volts, a 3-phase motor draws 2.5 amp per HP
	At 230 volts, a single-phase motor draws 5 amp per HP
	At 115 volts, a single-phase motor draws 10 amp per HP

Unit of Measure	Metric Measure	Conversion to Metric Factor	Metric to Std. (USA) Measure	
lb. ft.	kg. wt-m	0.13825	7.233035	Torque
lb. ft.	nt-m	1.35582	0.73757	Torque

TORQUE TO ACCELERATE A REVOLVING BODY

Torque (Lbs. Ft.) = $\frac{WR^2N}{307 \times t}$

WR² = inertia
 N = change in rpm
 t = time of acceleration in seconds

Inertia of a solid cylinder about its axis

WR² = $\frac{\text{Weight (Lbs.)} \times [\text{Radius (Ft.)}]^2}{2}$

Inertia of a hollow cylinder about its axis

WR² = $\frac{\text{Wt. (Lbs.)} \times [(\text{Outer Rad. in Ft.})^2 - (\text{Inner Rad. in Ft.})^2]}{2}$

CONVERTING LINEAR TO ROTATIONAL INERTIA

Equivalent WR² = $\frac{W}{39.48} \left(\frac{V}{N}\right)^2$

W = Weight in pounds (lbs.)
 V = Linear Velocity in feet per min. (fpm) = .262 x Dia. (in.) x RPM
 N = Motor speed in rpm when load is moving at velocity V

EQUIVALENT WR² FOR BELTED OR GEARED LOADS

Equivalent (at Motor Shaft) WR² = WR²_(load) $\left(\frac{N_{\text{load}}}{N_{\text{motor}}}\right)^2$

WR²_{load} = Actual WR²_(load)

N_{load} = Full Speed of Load (rpm)
 N_{motor} = Full Speed of Motor (rpm)

MISCELLANEOUS CONSTANTS

Gravitation Const. -g = Acceleration due to gravity = 32.16 feet per second per second.

Power 1 horsepower = 746 watts = 33,000 ft. lbs. per minute

Mech. equiv. heat One BTU = .2928 watt hours
 one kilowatt = 56.88 BTU per minute

Atmospheric Pressure 14.7 lbs. 1 square inch = 30 inches of mercury at 62°F

Pi (π) 3.1416 ratio circumference to diameter of circle

Base of Natural Logarithms 2.71828

Radian 57°17'44" = 57.296 deg.

Engineering Information

AGMA Service Factors and Load Classifications

Application	Recommended Service Factors		
	Up to 3 Hrs/Day	3 - 10 Hrs/Day	Over 10 Hrs/Day
AGITATORS (Mixers)			
Pure Liquids	—	1.00	1.25
Liquids & Solids	1.00	1.25	1.50
Liquids - Variable Density	1.00	1.25	1.50
BLOWERS			
Centrifugal	1.00	1.25	—
Lobe	1.00	1.25	1.50
Vane	—	1.00	1.25
BREWING & DISTILLING			
Bottling Machinery	—	1.00	1.25
Brew Kettles (Continuous Duty)	—	1.00	1.25
Cookers (Continuous Duty)	—	1.00	1.25
Mush Tubs (Continuous Duty)	—	1.00	1.25
Scale Hopper (Frequent Starts)	1.00	1.25	1.50
CAN FILLING MACHINES	—	1.00	1.25
CAR DUMPERS	1.25	1.50	1.75
CAR PULLERS	1.00	1.25	1.50
CLARIFIERS		1.00	1.25
CLASSIFIERS	1.00	1.25	1.50
CLAY WORKING MACHINERY			
Brick Press	1.25	1.50	1.75
Briquette Machine	1.25	1.50	1.75
Pug Mill	1.00	1.25	1.50
COMPACTORS	1.50	1.75	2.00
COMPRESSORS			
Centrifugal	—	1.00	1.25
Lobe	1.00	1.25	1.50
Reciprocating, Multi - Cylinder	1.00	1.25	1.50
Reciprocating, Single - Cylinder	1.25	1.50	1.75
CONVEYORS - GENERAL PURPOSE			
Uniformly loaded or fed	—	1.00	1.25
Not uniformly fed	1.00	1.25	1.50
Reciprocating or Shaker	1.25	1.50	1.75
CRANES			
Dry Dock			
Main Hoist	1.25	1.50	1.75
Auxiliary Hoist	1.25	1.50	1.75
Boom Hoist	1.25	1.50	1.75
Slewing Drive	1.25	1.50	1.75
Traction Drive	1.50	1.50	1.50
Container			
Main Hoist		*	
Boom Hoist		*	
Trolley Travel		*	
Gantry Drive		*	
Traction Drive		*	
Mill Duty			
Main Hoist		*	
Auxiliary		*	
Bridge and Trolley Travel		*	

Application	Recommended Service Factors		
	Up to 3 Hrs/Day	3 - 10 Hrs/Day	Over 10 Hrs/Day
CRANES (Cont.)			
Industrial Duty			
Main	1.00	1.25	1.50
Auxiliary		*	
Bridge and Trolley Travel		*	
CRUSHER			
Stone or Ore	1.50	1.75	2.00
DREDGES			
Cable Reels	1.00	1.25	1.50
Conveyors	1.00	1.25	1.50
Cutter Head Drives	1.25	1.50	1.75
Pumps	1.00	1.25	1.50
Screen Drives	1.25	1.50	1.75
Stackers	1.00	1.25	1.50
Winches	1.00	1.25	1.50
ELEVATORS			
Bucket	1.00	1.25	1.50
Centrifugal Discharge	—	1.00	1.25
Escalators		*	
Freight		*	
Gravity Discharge	—	1.00	1.25
EXTRUDERS			
General	1.25	1.25	1.25
Plastics			
(a) Variable Speed Drive	1.50	1.50	1.50
(b) Fixed Speed Drive	1.75	1.75	1.75
Rubber			
(a) Continuous Screw Operation	1.50	1.50	1.50
(b) Intermittent Screw Operation	1.75	1.75	1.75
FANS			
Centrifugal	—	1.00	1.25
Cooling Towers		*	
Forced Draft	1.25	1.25	1.25
Induced Draft	1.00	1.25	1.50
Industrial & Mine	1.00	1.25	1.50
FEEDERS			
Apron	—	1.25	1.50
Belt	1.00	1.25	1.50
Disc	—	1.00	1.25
Reciprocating	1.25	1.50	1.75
Screw	1.00	1.25	1.50
FOOD INDUSTRY			
Cereal Cooker	—	1.00	1.25
Dough Maker	1.00	1.25	1.50
Meat Grinder	1.00	1.25	1.50
Slicers	1.00	1.25	1.50
GENERATORS & EXCITERS	—	1.00	1.25
HAMMER MILLS	1.50	1.50	1.75
HOISTS			
Heavy Duty	1.25	1.50	1.75
Medium Duty	1.00	1.25	1.50
Skip Hoist	1.00	1.25	1.50

* Refer to company

Engineering Information

AGMA Service Factors and Load Classifications

Application	Recommended Service Factors		
	Up to 3 Hrs/Day	3 - 10 Hrs/Day	Over 10 Hrs/Day
LAUNDRY TUMBLERS	1.00	1.25	1.50
LAUNDRY WASHERS	1.25	1.25	1.50
LUMBER INDUSTRY			
Barkers - Spindle Feed	1.25	1.25	1.50
- Main Drive	1.50	1.50	1.50
Conveyors - Burner	1.25	1.25	1.50
- Main or Heavy Duty	1.50	1.50	1.50
- Main Log	1.50	1.50	1.75
- Re-Saw, Merry-Go-Round	1.25	1.25	1.50
- Slab	1.50	1.50	1.75
- Transfer	1.25	1.25	1.50
Chains - Floor	1.50	1.50	1.50
- Green	1.50	1.50	1.50
Cut-Off Saws - Chain	1.50	1.50	1.50
- Drag	1.50	1.50	1.50
Debarking Drums	1.50	1.50	1.75
Feeds - Edger	1.25	1.25	1.50
- Gang	1.50	1.50	1.50
- Trimmer	1.25	1.25	1.50
Log Deck	1.50	1.50	1.50
Log Hauls - Incline - Well Type	1.50	1.50	1.50
Log Turning Devices	1.50	1.50	1.50
Planer Feed	1.25	1.25	1.50
Planer Tilting Hoist	1.50	1.50	1.50
Rolls - Live, Off Brg., Roll Cases	1.50	1.50	1.50
Sorting Table	1.25	1.25	1.50
Tipple Hoist	1.25	1.25	1.50
Transfers - Chain	1.50	1.50	1.50
- Craneway	1.50	1.50	1.50
Tray Drives	1.25	1.25	1.50
Veneer Lathe Drives		*	
METAL MILLS			
Draw Bench Carriage & Main Drive	1.00	1.25	1.50
Run Out Tables			
Non-Reversing			
Group Drives	1.00	1.25	1.50
Individual Drives	1.50	1.50	1.75
Reversing	1.50	1.50	1.75
Slab Pushers	1.25	1.25	1.50
Shears	1.50	1.50	1.75
Wire Drawing	1.00	1.25	1.50
Wire Winding Machine	1.00	1.25	1.50
METAL STRIP PROCESSING			
MACHINERY			
Bridles	1.25	1.25	1.50
Coilers & Uncoilers	1.00	1.00	1.25
Edge Trimmers	1.00	1.25	1.50
Flatteners	1.00	1.25	1.50
Loopers (Accumulators)	1.00	1.00	1.00
Pinch Rolls	1.00	1.25	1.50
Scrap Choppers	1.00	1.25	1.50
Shears	1.50	1.50	1.75
Slitters	1.00	1.25	1.50
MILLS, ROTARY TYPE			
Bell & Rod			
Spur Ring Gear	1.50	1.50	1.75
Helical Ring Gear	1.50	1.50	1.50

Application	Recommended Service Factors		
	Up to 3 Hrs/Day	3 - 10 Hrs/Day	Over 10 Hrs/Day
MILLS, ROTARY TYPE (Cont.)			
Direct Connected	1.50	1.50	1.75
Cement Kilns	1.50	1.50	1.50
Dryers & Coolers	1.50	1.50	1.50
MIXERS, CONCRETE	1.00	1.25	1.50
PAPER MILLS			
Agitator (Mixer)	1.50	1.50	1.50
Agitator for Pure Liquids	1.25	1.25	1.25
Barker Drums	1.75	1.75	1.75
Barker - Mechanical	1.75	1.75	1.75
Beater	1.50	1.50	1.50
Breaker Stack	1.25	1.25	1.25
Calender (Anti-Friction Bearings Only)	1.25	1.25	1.25
Chipper	1.75	1.75	1.75
Chip Feeder	1.50	1.50	1.50
Coating Rolls	1.25	1.25	1.25
Conveyors			
Chip, Bark, Chemical	1.25	1.25	1.25
Log (Including Slab)	1.75	1.75	1.75
Couch Rolls	1.25	1.25	1.25
Cutter	1.75	1.75	1.75
Cylinder Molds	1.25	1.25	1.25
Dryers (Anti-Friction Bearings Only)			
Paper Machine	1.25	1.25	1.25
Conveyor Type	1.25	1.25	1.25
Embossers	1.25	1.25	1.25
Extruder	1.50	1.50	1.50
Fourdrinier Rolls (Includes Lump Breaker, Dandy Roll, Wire Turning & Return Rolls)	1.25	1.25	1.25
Jordan	1.25	1.25	1.25
Kiln Drive	1.50	1.50	1.50
Mt. Hope Rolls	1.25	1.25	1.25
Paper Rolls	1.25	1.25	1.25
Platter	1.50	1.50	1.50
Pressers - Felt & Suction	1.25	1.25	1.25
Pulper	1.50	1.50	1.75
Pumps - Vacuum	1.50	1.50	1.50
Reel (Surface Type)	1.25	1.25	1.50
Screens			
Chip	1.50	1.50	1.50
Rotary	1.50	1.50	1.50
Vibrating	1.75	1.75	1.75
Size Press	1.25	1.25	1.25
Super Calender	1.25	1.25	1.25
Thickener (AC Motor)	1.50	1.50	1.50
(DC Motor)	1.25	1.25	1.25
Washer (AC Motor)	1.50	1.50	1.50
(DC Motor)	1.25	1.25	1.25
Wind & Unwind Stand	1.00	1.00	1.00
Winders (Surface Type)	1.25	1.25	1.25
Yankee Dryers (Anti-Friction Bearings Only)	1.25	1.25	1.25
PLASTICS INDUSTRY – PRIMARY PROCESSING			
Intensive Internal Mixers	1.75	1.75	1.75
(a) Batch Mixers	1.50	1.50	1.50

* Refer to company

Engineering Information

AGMA Service Factors and Load Classifications

Application	Recommended Service Factors		
	Up to 3 Hrs/Day	3 - 10 Hrs/Day	Over 10 Hrs/Day
PLASTICS INDUSTRY – PRIMARY PROCESSING (Cont.)			
(b) Continuous Mixers	1.50	1.50	1.50
Batch Drop Mill - 2 Smooth Rolls	1.25	1.25	1.25
Continuous Feed, Holding & Blend Mill	1.25	1.25	1.25
Compounding Mills	1.25	1.25	1.25
Calenders	1.50	1.50	1.50
PLASTICS INDUSTRY – SECONDARY PROCESSING			
Blow Molders	1.50	1.50	1.50
Coating	1.25	1.25	1.25
Film	1.25	1.25	1.25
Pipe	1.25	1.25	1.25
Pre-Plasticizers	1.50	1.50	1.50
Rods	1.25	1.25	1.25
Sheet	1.25	1.25	1.25
Tubing	1.25	1.25	1.50
PULLERS - BARGE HAUL PUMPS			
Centrifugal	—	1.00	1.25
Proportioning	1.00	1.25	1.50
Reciprocating			
Single Acting, 3 or more cylinders	1.00	1.25	1.50
Double Acting, 2 or more cylinders	1.00	1.25	1.50
Rotary - Gear Type	—	1.00	1.50
- Lobe	—	1.00	1.25
- Vane	—	1.00	1.25
RUBBER INDUSTRY			
Intensive Internal Mixers			
(a) Batch Mixers	1.50	1.75	1.75
(b) Continuous Mixers	1.25	1.50	1.50
Mixing Mill			
2 Smooth Rolls (if corrugated rolls are used, than the same service factors that are used for a Cracker Warmer)	1.50	1.50	1.50
Batch Drop Mill - 2 Smooth Rolls	1.50	1.50	1.50
Cracker Warmer - 2 Rolls; 1 corrugated roll	1.75	1.75	1.75
Cracker - 2 corrugated rolls	1.75	1.75	1.75

* Refer to company

Application	Recommended Service Factors		
	Up to 3 Hrs/Day	3 - 10 Hrs/Day	Over 10 Hrs/Day
RUBBER INDUSTRY (Cont.)			
Holding, Feed & Blend Mill			
- 2 Rolls	1.25	1.25	1.25
Refiner - 2 Rolls	1.50	1.50	1.50
Calenders	1.50	1.50	1.50
SAND MILLER	1.00	1.25	1.50
SEWAGE DISPOSAL EQUIPMENT			
Bar Screens	—	1.00	1.25
Chemical Feeders	—	1.00	1.25
Dewatering Screens	1.00	1.25	1.50
Scum Breakers	1.00	1.25	1.50
Slow or Rapid Mixers	1.00	1.25	1.50
Sludge Collectors	1.00	1.00	1.25
Thickeners	1.00	1.25	1.50
Vacuum Filters	1.00	1.25	1.50
SCREENS			
Air Washing	—	1.00	1.25
Rotary - Stone or Gravel	1.00	1.25	1.50
Traveling Water Intake	—	1.00	1.25
SUGAR INDUSTRY			
Beet Slicer	1.50	1.50	1.75
Cane Knives	1.50	1.50	1.50
Crushers	1.50	1.50	1.50
Mills (Low Speed End)	1.50	1.50	1.50
TEXTILE INDUSTRY			
Batchers	1.00	1.25	1.50
Calenders	1.00	1.25	1.50
Cards	1.00	1.25	1.50
Dry Cans	1.00	1.25	1.50
Dryers	1.00	1.25	1.50
Dyeing Machinery	1.00	1.25	1.50
Looms	1.00	1.25	1.50
Mangles	1.00	1.25	1.50
Nappers	1.00	1.25	1.50
Pads	1.00	1.25	1.50
Slashers	1.00	1.25	1.50
Soapers	1.00	1.25	1.50
Spinners	1.00	1.25	1.50
Tenter Frames	1.00	1.25	1.50
Washers	1.00	1.25	1.50
Winders	1.00	1.25	1.50

Service Factor Classification For Industry Applications

Applications which expose the gear drive to high starting torques, extreme repetitive shock, or where high energy loads must be absorbed as when stalling, require special consideration. Service factors for the special applications should be agreed upon by the user and Baldor since variations of the values in the chart may be required.

The service factors in the service factor table are based on the use of an electric or hydraulic motor or the use of a steam or gas turbine as a prime mover. If the prime mover is a single or multi-cylinder engine, then the service factor must be adjusted in accordance with the chart below.

CONVERSION FACTORS FOR INTERNAL COMBUSTION ENGINE DRIVERS		
Electric Motor Drive	Multi-Cylinder Internal Combustion Engine	Single-Cylinder Internal Combustion Engine
1.00	1.25	1.50
1.25	1.50	1.75
1.50	1.75	2.00
1.75	2.00	2.25
2.00	2.25	2.50

The applications and service factors are in accordance with the current AGMA Standard 6034-E87. This list is not all-inclusive and each application should be checked to determine if any unusual operating conditions will be encountered.

Baldor 900, Universal Series Worm Gear Reducer and Ratio Multiplier

Mounting and Installation Instruction

MOTOR MOUNTING INSTRUCTIONS

Quill Design

1. Position key in reducer worm bore. Apply anti-seize compound to the motor shaft. Line up the key with the keyslot and slip the motor shaft into the reducer worm bore.

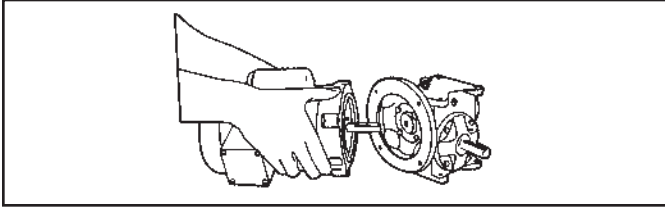

2. Tighten the supplied 4 bolts with lockwashers evenly for a solid fit between motor and "C" flange.

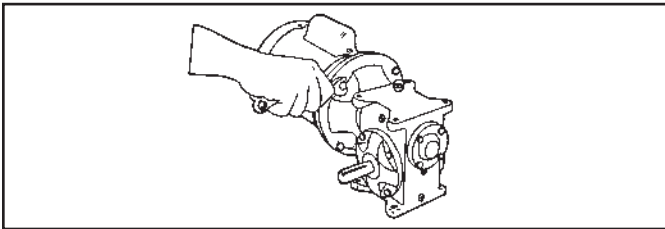

Flexible Coupling Input

- STEP #1.** Mount one coupling half on motor shaft so that coupling half and end of key are flush with end of motor shaft. (See Drawing A)
- STEP #2.** Tighten coupling setscrews. Thread locking compound is recommended on all coupling setscrews. Measure distance from inner face of coupling to motor mounting surface. (See Drawing A)
- STEP #3.** Mount other coupling half on the reducer input shaft so the coupling end measures the same distance to the mounting surface of the "C" flange. (See Drawing B) Tighten setscrews. Key should be flush with shaft end. Use pipe plug opening in side of "C" flange to loosen, tighten or make any adjustments in coupling position.
- STEP #4.** Align coupling halves and install motor.
- STEP #5.** Rotate motor to require position and tighten the supplied four bolts and lockwashers evenly for a solid fit between motor and "C" flange. Re-install and tighten the pipe plug in the flange access hole.

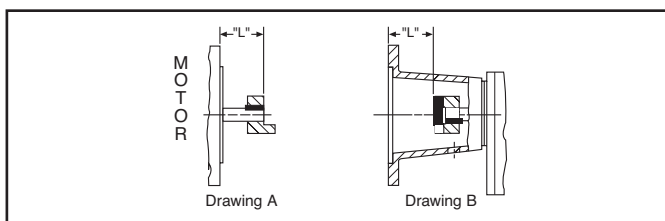

Follow the lubrication directions.

INSTALLATION

Careful adherence to the following installation suggestions will help you get maximum service and life from your Baldor Reducer.

Baldor Reducer shipments contain oil. Fill the reducer to the proper level with the supplied or recommended lubricant. (See the lubrication information section on next page for specific recommendations.)

ALIGNMENT – When installing Baldor Reducers, care should be taken to align input and output shafts vertically and horizontally with connecting shafts. A flat and even mounting surface will help prevent uneven base hole bolt pressures. Flexible couplings will help compensate for minor variations in shaft alignment.

C-Flanged reducers with hollow worm bore require attention to be sure that the key has maximum contact in the keyslots of both the input worm bore and the motor shaft. When mounting the motor to the reducer, the key should be inserted in the keyslot of the worm bore, not in the keyslot of the motor shaft.

Bolts and lockwashers for fastening the motor to the reducer are supplied with all Baldor C-Flanged Reducers and should be tightened securely and evenly to help avoid misalignment.

When mounting a sprocket, gear, or sheave, etc., on a reducer shaft, mount the working face as close to the reducer housing as possible. The gear or sprocket hub should be nearer the end of the shaft as shown in the illustration. Be careful not to damage the reducer oil seal when mounting the sprocket, gear, or sheave.

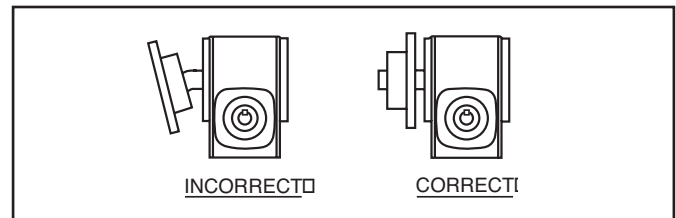

Installing in this manner reduces the load on the shaft and increases bearing life.

To reduce unnecessary load and obtain maximum reducer and component life, driving and driven sprockets or sheaves should be properly aligned with their mates and all shafts parallel. Gears should be mounted on shafts at the proper center to center distance.

Baldor 900 and Universal Series Worm Gear Reducer Installation, Maintenance and Lubrication

H50
Reducer

900 Series
Single Reduction

900 Series
Double Reduction

Accessories

Ratio Multipliers

In-Line Helical (LH)

Universal Series
Single Reduction

Universal Series
Double Reduction

Engineering

Reducers achieve maximum performance and life when installed properly. Please follow these instructions carefully.

INSTALLATION

Reducers filled with Kluber Klubersynth UH1-6-460 synthetic lubricant are ready for immediate use. These reducers are completely sealed and require no breather vents. The design and synthetic lubrication allow efficient operation to reduce operating temperature and minimize internal pressure build up. The reducer has been filled with the correct amount of oil for all approved mounting positions. Do not add or remove any oil during installation or after the break-in period.

Mount the reducer on a flat surface, to assure proper bolt tension and prevent damage to the mounting base. When direct coupling the reducer to the driven machine, carefully align the reducer output shaft to the input shaft of the driven machine. These shafts must be connected with a flexible coupling.

Power transmission components, such as sprockets, gears, or sheaves, mounted on the reducer shafts produce overhung loads. Mount these components as close as possible to the reducer with the hub facing outward. This mounting minimizes the load on the reducer shaft and bearings for increased life. Carefully align these components with their counterparts on the driven machine.

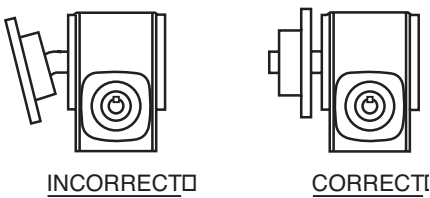

MAINTENANCE

Baldor reducers require no periodic maintenance. Visual inspection (for oil leakage and general operating condition) and a simple cleaning to remove dirt build up is recommended.

Accumulation of material on the reducer can lead to overheating and reduced life.

LUBRICATION

Klubersynth UH1-6-460 is suitable for USDA Class H1 environments. This synthetic lubrication does not require periodic changing. The lubrication should only be

replaced when maintenance is performed that requires disassembly. Use only Klubersynth UH1-6-460. This lubrication is suitable for a wide temperature range (-13° to 320° F sump temperature). However, refer to “**Operating Environment**” section for the ambient operating temperature for Baldor speed reducers.

MOUNTING POSITIONS

Because Baldor speed reducers do not require a breather vent, they are suitable for mounting in a wide variety of mounting positions without modification.

Avoiding those positions where the high-speed (input) oil seal is immersed in oil, will provide greater security against high-speed (input) seal wear. **For maximum seal life, the reducer should be mounted with the high-speed (input) shaft as high as possible above the low-speed (output) shaft.** Since the high-speed (input) oil seal experiences more revolutions than the output, it will also experience more heat and more wear. When the speed reducer is mounted in a manner where the high-speed (input) seal is below the oil level, and the seal is nearing the end of its useful life, the steady head of oil on the seal will result in a leak. If the reducer is mounted with the high-speed (input) seal above the oil level it may not leak even when the seal has reached the end of its useful life.

OPERATING ENVIRONMENT

Baldor Reducers are designed to operate in ambient temperatures of -10°F to 100°F. The oil sump temperature of the reducer must not exceed 200°F. Consult the factory for applications requiring ambient operating temperature outside this range.

The input horsepower rating shown on the nameplate of each Baldor speed reducer is the continuous mechanical rating of 1.0 service factor at 1750 RPM. Before placing the reducer into service, confirm that its horsepower rating is consistent with the motor horsepower and desired service factor.

IMPORTANT NOTE: Baldor speed reducers built prior to June, 2004, have a bladder system. The bladder system was designed specifically for SHC (synthetic hydro carbon) oils and is not compatible with Klubersynth UH1-6-460. The bladder must be removed and housing port plugged when re-filling with Klubersynth UH1-6-460. See instructions on page 192.

Baldor 900 Series Worm Gear Speed Reducers

Double Reduction Adapter Kits Assembly Instructions

1. REMOVING PRIMARY UNIT OUTPUT BEARING CARRIER

- The unit is filled with oil. Follow these instructions to avoid spilling the oil.
- Place the primary unit on its side with the output shaft pointing vertically upward.
- Remove the bearing carrier screws and retain for re-assembly.
- Remove the bearing carrier and shims taking care not to damage the bearing cone which is located on the output shaft.

2. INSTALLING THE DOUBLE REDUCTION ADAPTER

- Care must be taken not to damage the seal in the adapter during installation. Cover the output shaft keyway of the primary unit with electrical tape to prevent the seal from being cut.
- Lubricate the lip of the seal in the adapter and the output shaft of the primary unit.

The installation of the adapter requires adjustment for proper endplay of the tapered roller bearings. The output bearings must be adjusted for .001" to .003" endplay. Place the adapter on the primary unit in place of the bearing carrier. Apply pressure to the adapter and rotate the input shaft to seat the bearings. Measure the gap between the primary housing and adapter with a feeler gage. New shims are supplied with the unit. Select a combination of shims totaling .001" to .003" more than the measured gap. Shim thicknesses are .003" (green), .005" (blue), and .010" (brown).

- Remove the adapter. Apply sealant to the mating surfaces of the adapter and the primary unit.
- Install and tighten the original screws securely. Remove the tape.

3. CONNECTING THE PRIMARY UNIT TO THE SECONDARY

- Remove and discard the motor adapter mounting screws and motor adapter from the secondary unit.
- Install the key provided with the primary unit into the primary unit output shaft.
- Coat the primary unit output shaft with anti-seize compound provided with the secondary unit.
- Install the primary unit output shaft into the quill of the secondary unit.
- Rotate the primary unit to the desired position.
- Using the four screws provided with the adapter kit, join the primary unit to the secondary.

*See page 79 for Kit Part Numbers.

Baldor 900 Series Worm Gear Reducer Polyglycol Retro-Fill Instructions

HFO Reducer

900 Series Single Reduction

900 Series Double Reduction

Accessories

Ratio Multipliers

In-Line Helical (LH)

Universal Series Single Reduction

Universal Series Double Reduction

Engineering

IMPORTANT NOTE: Polyglycol oil is not compatible with the bladder material, and may cause degradation and failure of the expansion bladder. The bladder must be removed and the housing port plugged using the included hardware.

DISASSEMBLY AND BLADDER REMOVAL

1. Drain the oil from the reducer.
2. Wrap output shaft with electrical tape to prevent damage to the seal lip.
3. Remove the bolts holding the side covers.
4. Remove the gear shaft assembly and side covers, taking care not to damage the shim gaskets.

Be sure to keep the shims with the cover on which they are installed. Failure to do so will result in improper positioning of the gear.

5. Remove the nut and sealing washer holding the bladder in place.
 6. Remove and discard the nylon bladder support arch (if present) and bladder.
- Note: It is not necessary to remove the worm shaft.**
7. Thoroughly clean and flush all parts.
 8. Remove the red bladder warning sticker.

PLUG INSTALLATION AND RE-ASSEMBLY

1. Insert 1/4-20 screw through the housing port from the inside.
2. Install sealing washer & nut, and tighten firmly.
3. Re-assemble the reducer making sure to keep the shims with their proper side cover. ***Failure to do so will result in improper positioning of the gear.***
4. Tighten the bolts in an alternating pattern.
5. Refill with the appropriate quantity of polyglycol oil from the table below.

Note: In most cases, the kit contains more oil than is required. Discard any remaining oil.

Frame	Qty.	Kit Number	Frame	Qty.	Kit Number
913	7 oz	MJ0007A01SP	926	32 oz	MJ0007A04SP
915	11 oz	MJ0007A02SP	930	53 oz	MJ0007A05SP
918	16 oz	MJ0007A03SP	932	68 oz	MJ0007A06SP
921	20 oz	MJ0007A03SP	938	93 oz	MJ0007A07SP
924	28 oz	MJ0007A04SP			

6. Place the yellow Klubersynth UH-1 6-460 sticker on the reducer in a conspicuous location.

Ratio Multiplier

Installation, Lubrication and Operation Instruction

These instructions must be read thoroughly before installing or operating speed reducers. File instructions for future reference.

CAUTION

- For safe operation of any gear drive, all rotating shafts and auxiliary components must be shielded to conform with applicable safety standards. You must consider overall operational system safety at all times.
- When using a speed reducer to raise or lower a load, such as in hoisting applications, provision must be made for external braking. Under no conditions should a speed reducer be considered self-locking.
- Mounting of speed reducers in overhead positions may be hazardous. Use of external guides or supports is strongly recommended for overhead mounting.

GENERAL INSTRUCTIONS

Align all shafts accurately. Improper alignment can result in failure. Use of flexible coupling is recommended to compensate for slight misalignment.

Auxiliary drive components (such as sprockets, gears and pulleys) should be mounted on the shafts as close as possible to the housing to minimize effects of overhung loads. Avoid force fits that might damage bearings or gears.

Gear drives are nameplated for 1750 RPM Input Speed and Class I Service. For lower Input Speeds and other Service Classes, consult the factory.

INSTALLATION

Baldor Ratio Multipliers are ready for installation as removed from the carton. Each Ratio Multiplier has been filled with Klubersynth GH6-460 lubricant at the factory, the oil quality is sufficient for any mounting position.

MOUNTING POSITION

For maximum seal life, the Ratio Multiplier should be mounted with the input shaft as high as possible. **Mounting the Ratio Multiplier with the input seal vertically down is not recommended.** If a vertically down input shaft position is required, consult the factory.

LUBRICATION

Oil changes are not required. Oil should only be replaced when maintenance is preformed that requires disassembly. If the oil is replaced, use Klubersynth GH6-460.

This lubrication is suitable for a wide temperature range (-13° to 320°F sump temperature). However, refer to “Operating Environment” section for the ambient operating temperature for Baldor speed reducers.

(Oil capacity in fluid ounces **RM1** 6 oz, **RM2** 10 oz.

OPERATING ENVIRONMENT

Baldor Ratio Multipliers are designed to operate in ambient temperatures of -10°F to 100°F. The oil sump temperatures of the Ratio Multiplier must not exceed 200°F. Consult the factory for applications requiring ambient operating temperature outside this range.

“C” FLANGE – HOLLOW BORE WORM STYLE:

STEP #1. Position key in Ratio Multiplier Input Bore. Apply anti-seize compound to the motor shaft. Line up the key with the keyslot and slip the motor shaft into the Ratio Multiplier Input Bore.

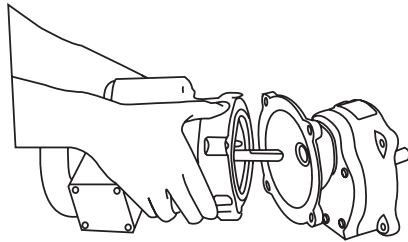

STEP 2. Tighten the supplied 4 bolts with lockwashers evenly for a solid fit between motor and “C” flange.

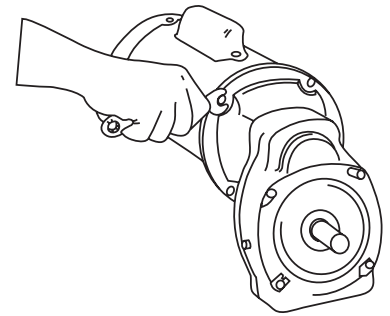

EXTENDED “C” FLANGE WITH FLEXIBLE COUPLING STYLE:

STEP #1: Mount one coupling half on motor shaft so that the coupling half and end of key are flush with end of motor shaft. (See Drawing A)

STEP #2: Tighten coupling setscrews. Thread locking compound is recommended on all coupling setscrews. Measure distance from inner face of coupling to motor mounting surface. (See Drawing A)

STEP #3: Mount other coupling half on the reducer input shaft so the coupling end measures the same distance to the mounting surface of the “C” flange. (See Drawing B) Tighten setscrews. Key should be flush with shaft end. Use pipe plug opening in side of “C” flange to loosen, tighten or make any adjustments in coupling position.

STEP #4: Align coupling halves and install motor.

STEP #5: Rotate motor to required position and tighten the supplied four bolts and lockwashers evenly for a solid fit between motor and “C” flange. Re-install and tighten the pipe plug in the flange access hole.

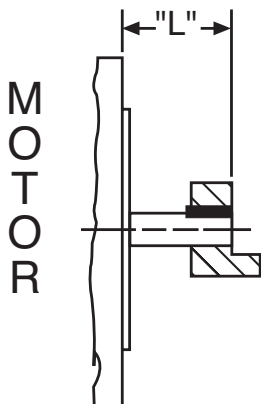

Drawing A

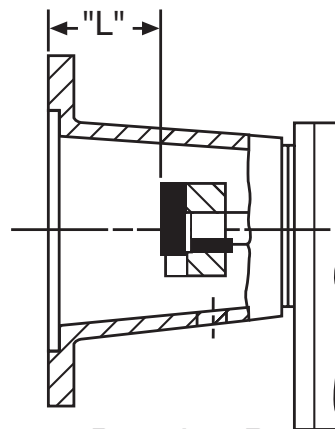

Drawing B

H50 Reducer
900 Series Single Reduction
900 Series Double Reduction
Accessories
Ratio Multipliers
In-Line Helical (LH)
Universal Series Single Reduction
Universal Series Double Reduction
Engineering

900 Series Parts Lists

Single Reduction

Model F – Sizes 913 through 932

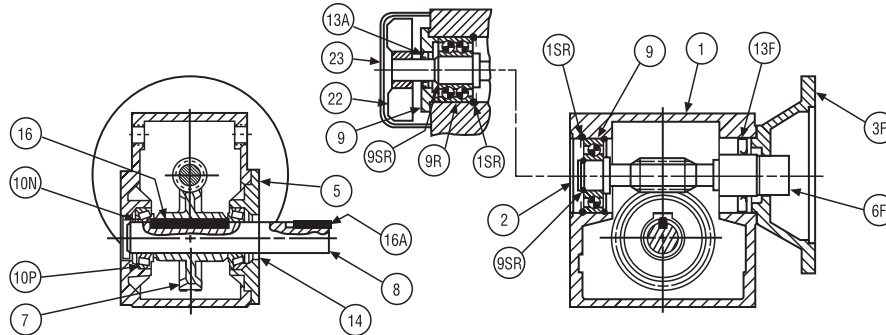

Item No.	Quantity	Description	Item No.	Quantity	Description
1	1	Housing	13A	1	I/P oil seal-rear (size 932)
1SR	2	Retaining ring-housing (size 913-926)	13F	1	I/P Oil seal-front
1SR	1	Retaining ring-housing (size 932)	14	1	O/P oil seal
2	1	I/P bore end cap	16	1	Gear key
3	1	Worm end cap (size 932)	16A	1	O/P shaft key
3F	1	Motor flange	17	1	Vent plug (not shown)
5	1	O/P bearing carrier	18	4	Oil level and drain plugs (not shown)
6F	1	Worm	22	1	Fan (size 932)
7	1	Worm gear	23	1	Fan guard (size 932)
8	1	O/P shaft-single projection	31	1	Baffle (not shown)
8A	1	O/P shaft-double projection (not shown)	71 A/B	1	Horizontal mounting base (not shown)
9	1	I/P bearing (size 913-926)	81 D/F	2	Angle feet (low base) (not shown)
9R	1	I/P bearing (size 932)	91 C/E	2	Angle feet (high base) (not shown)
9SR	1	Retaining ring-worm			
10N	2	O/P bearing-cone			
10P	2	O/P bearing-cup			

Models S & LF – Sizes 913 through 932

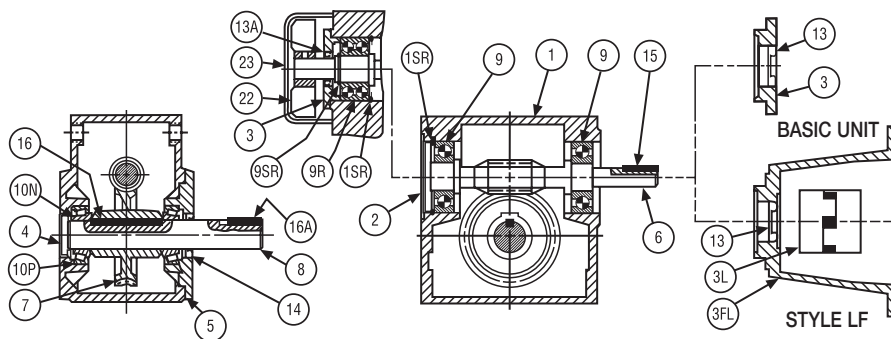

Item No.	Quantity	Description	Item No.	Quantity	Description
1	1	Housing	10P	2	O/P bearing-cup
1SR	1	Retaining ring-housing (size 913-926)	13	1	I/P oil seal
2	1	I/P bore end cap	13A	1	I/P Oil seal-rear (size 932)
3	1	Worm end cap (size 913-926)	14	1	O/P oil seal
3	2	Worm end cap (size 932)	15	1	I/P shaft key
3FL	1	Extended Motor flange	16	1	Gear key
3L	1	Coupling (complete)	16A	1	O/P shaft key
4	1	O/P bore end cap	17	1	Vent plug (not shown)
5	1	O/P bearing carrier	18	4	Oil level and drain plugs (not shown)
6	1	Worm	22	1	Fan (size 932)
7	1	Worm gear	23	1	Fan guard (size 932)
8	1	O/P shaft-single projection	31	1	Baffle (not shown)
8A	1	O/P shaft-double projection (not shown)	71 A/B	1	Horizontal mounting base (not shown)
9	2	I/P bearing (size 913-926)	81 D/F	2	Angle feet (low base) (not shown)
9	1	I/P bearing-front (size 932)	91 C/E	2	Angle feet (high base) (not shown)
9R	1	I/P bearing-rear (size 932)			
9SR	1	Retaining ring-worm (size 932)			
10N	2	O/P bearing-cone			

900 Series Parts Lists

Double Reduction

Models FDA, FDB & FDC – Sizes 918 through 932

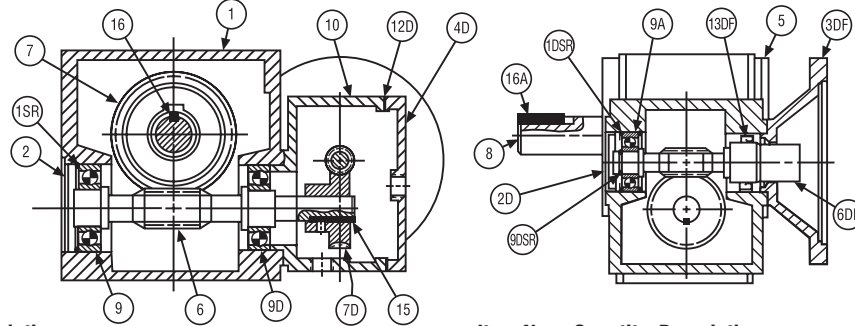

Item No.	Quantity	Description
1	1	Housing-second reduction
1D	1	Housing-first reduction
1DSR	2	Retaining ring-first reduction housing
1SR	1	Retaining ring-second reduction housing
2	1	I/P bore end cap-second reduction
2D	1	I/P bore end cap-first reduction
3	1	Worm end cap-second reduction (size 932) (not shown)
3DF	1	Motor flange
4	1	O/P bore end cap-second reduction (not shown)
4D	1	Housing cover-first reduction
5	1	O/P bearing carrier-second reduction
6	1	Worm-second reduction
6DF	1	Worm-first reduction
7	1	Worm gear-second reduction
7D	1	Worm gear-first reduction
8	1	O/P shaft-single projection-second reduction
8A	1	O/P shaft-double projection-second reduction (not shown)
9	1	I/P bearing rear-second reduction
9A	1	I/P bearing-first reduction

Item No.	Quantity	Description
9D	1	I/P bearing-front-second reduction
9DSR	1	Retaining ring-worm-first reduction
9R	1	I/P bearing-rear-second reduction (size 932) (not shown)
9SR	1	Retaining ring-worm-second reduction (size 932) (not shown)
10N	2	O/P bearing-cone-second reduction (not shown)
10P	2	O/P bearing-cup-second reduction (not shown)
12D	1	Housing cover gasket-first reduction
13DF	1	I/P oil seal-first reduction
14	1	O/P oil seal-second reduction
15	1	I/P shaft key-second reduction
16	1	Gear key-second reduction
16A	1	O/P shaft key-second reduction
17	1	Vent plug (not shown)
18	8	Oil level and drain plugs (not shown)
31	1	Baffle (not shown)
71 A/B	1	Horizontal mounting base (not shown)
81 D/F	2	Angle feet (low base) (not shown)
91 C/E	2	Angle feet (high base) (not shown)

Models DA, DB, DC, LFDA, LFDB & LFDC – Sizes 913 through 932

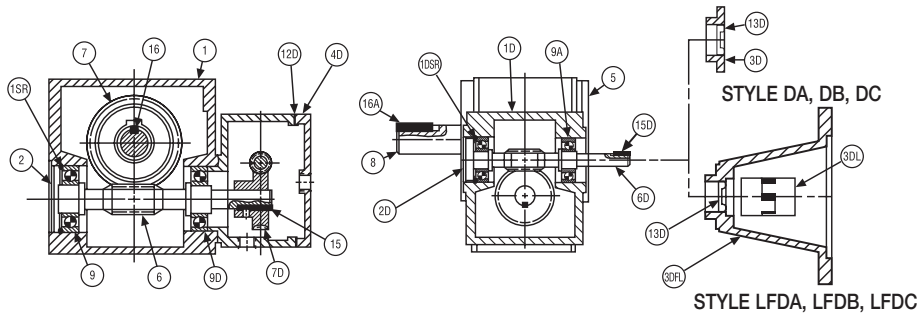

Item No.	Quantity	Description
1	1	Housing-second reduction
1D	1	Housing-first reduction
1DSR	1	Retaining ring ring-housing-first reduction
1SR	1	Retaining ring-housing-second reduction
2	1	I/P bore end cap-second reduction
2D	1	I/P bore end cap-first reduction
3	1	Worm end cap-second reduction (size 913-926) (not shown)
3D	1	Worm end cap-first reduction
3DFL	1	Extended Motor flange
3DL	1	Coupling (complete)
4	1	O/P bore end cap-second reduction (not shown)
4D	1	Housing cover-first reduction
5	1	O/P bearing carrier-second reduction
6	1	Worm-second reduction
6D	1	Worm-first reduction
7	1	Worm gear-second reduction
7D	1	Worm gear-first reduction
8	1	O/P shaft-single projection-second reduction
8A	1	O/P shaft-double projection-second reduction (not shown)
9	1	I/P bearing rear-second reduction
9A	2	I/P bearing-first reduction

Item No.	Quantity	Description
9D	1	I/P bearing-front-second reduction
9R	1	I/P bearing-rear-second reduction (size 932) (not shown)
9SR	1	Retaining ring-worm-second reduction (size 932) (not shown)
10N	2	O/P bearing-cone-second reduction (not shown)
10P	2	O/P bearing-cup-second reduction (not shown)
12D	1	Housing cover gasket-first reduction
13D	1	I/P oil seal-first reduction
14	1	O/P oil seal-second reduction
15	1	I/P shaft key-second reduction
15D	1	I/P shaft key-first reduction
16	1	Gear key-second reduction
16A	1	O/P shaft key-second reduction
17	1	Vent plug (not shown)
18	8	Oil fill and drain plugs (not shown)
31	1	Baffle (not shown)
71 A/B	1	Horizontal mounting base (not shown)
81 D/F	2	Angle feet (low base) (not shown)
91 C/E	2	Angle feet (high base) (not shown)

Universal Series Parts Lists

Single Reduction

Styles SB, ST, SV – Sizes 133 through 300

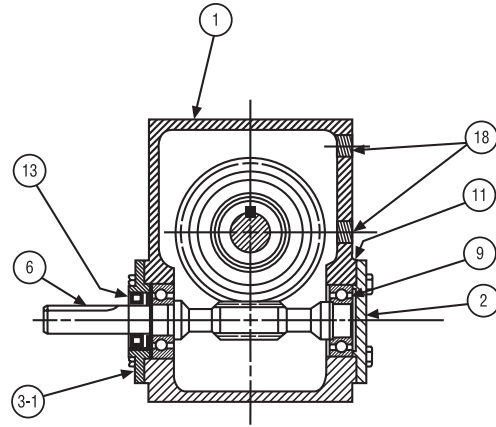
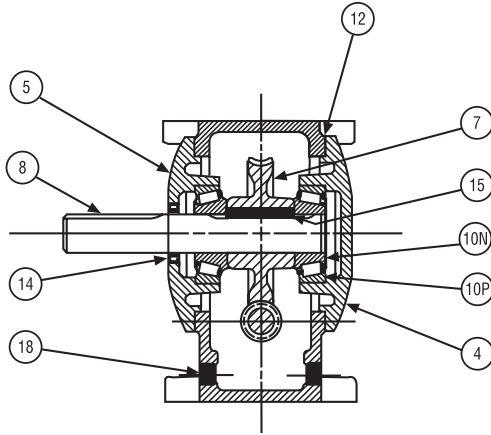

Item No.	Quantity	Description
1	1	Housing
2	1	Worm gland-closed
3-1	1	Worm gland-open
4	1	Gear gland-closed
5	1	Gear gland-open
6	1	Worm and shaft integral
7	1	Worm gear-bronze forging
8	1	Worm gear shaft-single proj.
8A	1	Worm gear shaft-double proj. (not shown)
9	1	Worm shaft ball bearing

Item No.	Quantity	Description
10N	2	Output shaft taper roller bearings
10P	2	Output shaft bearing cup
11	4	Input gland gaskets
12	4	Output gear gland gaskets
13	1	Input worm shaft oil seal
14	1	Output gear shaft oil seal
15	1	Gear shaft key
17	1	Vent plug (not shown)
18	6	Oil level and drain plugs
20	1 pr.	Angle feet for SV mtg. (not shown)

Styles SB, ST, SV – Sizes 350 through 600

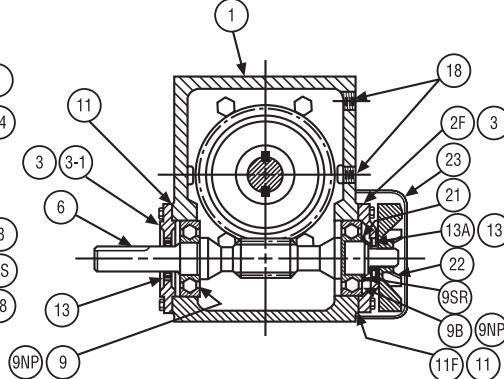
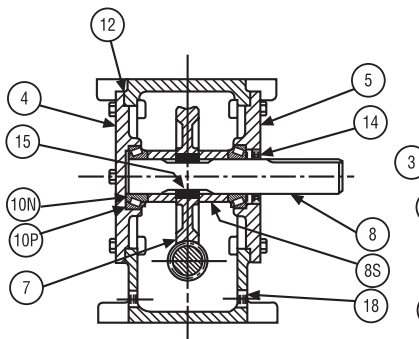

Item No.	Quantity	Description
1	1	Housing
2F	1	Worm gland-open (350-400 only)
3	1	Worm gland-open (500-600 only)
3-1	1	Worm gland open (350-400 only)
4	1	Gear gland-closed
5	1	Gear gland-open
6	1	Worm and shaft integral
7	1	Worm gear-bronze forging
8	1	Output gear shaft single ext.
8A	1	Output gear shaft double ext. (not shown)
8S	2	Gear shaft spacers
9	1	Input shaft-bearing front (350-400 only)
9B	1	Input shaft-bearing rear (350-400 only)
9N	2	Input shaft-taper roller bearing (500-600 only)
9P	2	Input shaft-bearing cup (500-600 only)
9SR	1	Input shaft-snap ring (350-400 only)

Item No.	Quantity	Description
10N	2	Output shaft taper roller bearing cone
10P	2	Output shaft bearing cups
11	2	Worm gland-gaskets
11F	2	Input gland-gaskets (350-400 only)
12	4	Gear gland gaskets
13	1	Input motor flange oil seal-front (front & rear 500 and 600 only)
13A	1	Input shaft oil seal-rear (350 and 400 only)
14	1	Gear shaft oil seal
15	2	Gear shaft keys
17	1	Vent plug (not shown)
18	6	Oil level and drain plugs
20	1 pr.	Angle feet for SV mtg. (not shown)
21	1	Input shaft washer
22	1	Fan
23	1	Fan guard

Universal Series Parts Lists

Single Reduction

Styles STF & SVF – Sizes 133 through 300

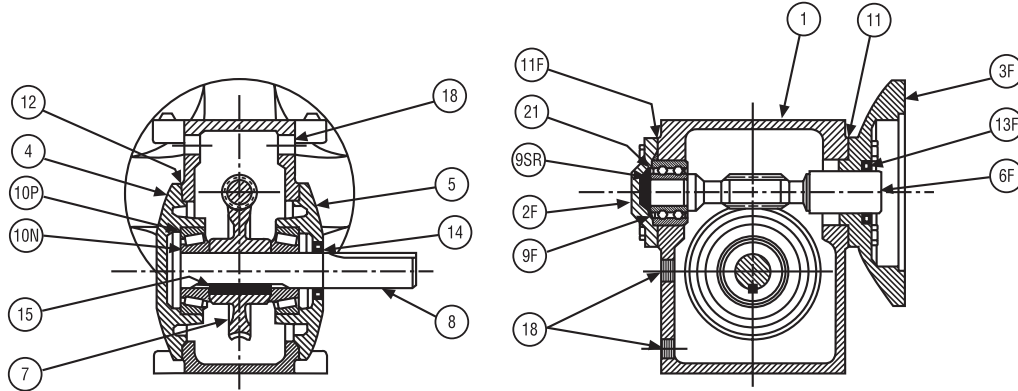

Item No.	Quantity	Description
1	1	Housing
2F	1	Worm gland-closed
3F	1	NEMA frame motor flange
4	1	Worm gear gland-closed
5	1	Worm gear gland-open
6F	1	Worm and shaft integral
7	1	Worm gear-bronze forging
8	1	Worm gear shaft-single proj.
8A	1	Worm gear shaft-double proj. (not shown)
9F	1	Motor worm ball bearing
9SR	1	Input shaft-snap ring
10N	2	Output shaft taper roller bearing cone

Item No.	Quantity	Description
10P	2	Output shaft bearing cup
11	1	Input gland gaskets
11F	1	Input gland gaskets
12	4	Output gear gland gaskets
13F	1	Input motor flange oil seal
14	1	Output shaft oil seal
15	1	Gear shaft key
17	1	Vent plug (not shown)
18	6	Oil level and drain plugs
20	1 pr.	Angle feet for SV mtg. (not shown)
21	1	Input worm washer

Styles STF & SVF – Sizes 350 and 400

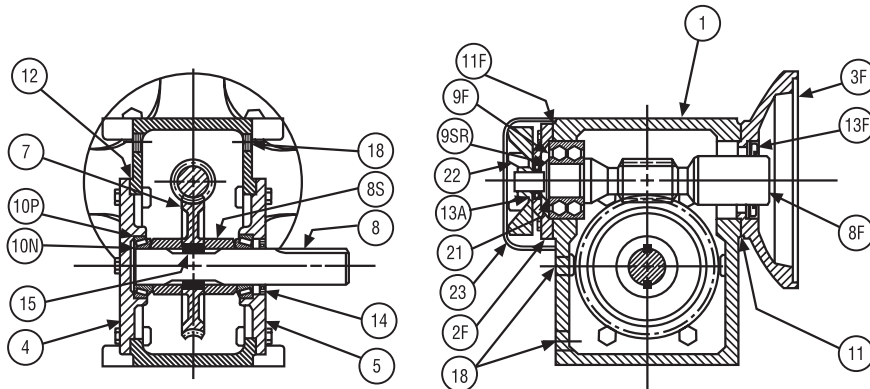

Item No.	Quantity	Description
1	1	Housing
2F	1	Worm gland-open (350-400 only)
3F	1	NEMA frame motor flange
4	1	Worm gear gland-closed
5	1	Worm gear gland-open
6F	1	Worm and shaft integral
7	1	Worm gear-bronze forging
8	1	Worm gear shaft-single proj.
8A	1	Worm gear shaft-double proj. (not shown)
8S	2	Gear shaft spacers
9F	1	Motor worm ball bearing
9SR	1	Snap ring (350-400 only)
10N	2	Output shaft taper roller bearing cone
10P	2	Output shaft bearing cup

Item No.	Quantity	Description
11	1	Input motor flange gasket
11F	1	Input gland gasket
12	4	Output gear gland gaskets
13	1	Input motor flange oil seal-front (front & rear 500 and 600 only)
13A	1	Input gland oil seal-rear
13F	1	Input motor flange oil seal-front
14	1	Output shaft oil seal
15	2	Gear shaft keys
17	1	Vent plug (not shown)
18	6	Oil level and drain plugs
20	1 pr.	Angle feet for SV mtg. (not shown)
21	1	Input worm washer
22	1	Fan
23	1	Fan guard

H50 Reducer

900 Series Single Reduction

900 Series Double Reduction

Accessories

Ratio Multipliers

In-Line Helical (LH)

Universal Series Single Reduction

Universal Series Double Reduction

Engineering

Universal Series Parts Lists

Single Reduction

Styles STI & SVI – Sizes 133 through 300

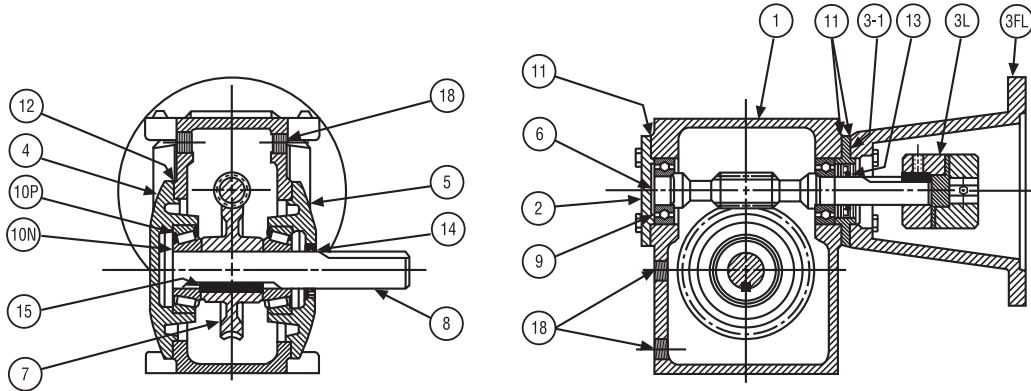

Item No.	Quantity	Description
1	1	Housing
2	1	Worm gland-closed
3L	1	Complete coupling
3-1	1	Input gland-open
3FL	1	NEMA frame motor flange
4	1	Worm gear gland-closed
5	1	Worm gear gland-open
6	1	Worm and shaft integral
7	1	Worm gear-bronze forging
8	1	Worm gear shaft-single proj.
8A	1	Worm gear shaft-double proj. (not shown)

Item No.	Quantity	Description
9	2	Motor worm ball bearing
10N	2	Output shaft taper roller bearing cone
10P	2	Output shaft bearing cup
11	3	Input gland gaskets
12	4	Output gear gland gaskets
13	1	Input motor flange oil seal
14	1	Output shaft oil seal
15	1	Gear shaft key
17	1	Vent plug (not shown)
18	6	Oil level and drain plugs
20	1 pr.	Angle feet for SV mtg. (not shown)

Styles STL & SVL – Sizes 350 and 600

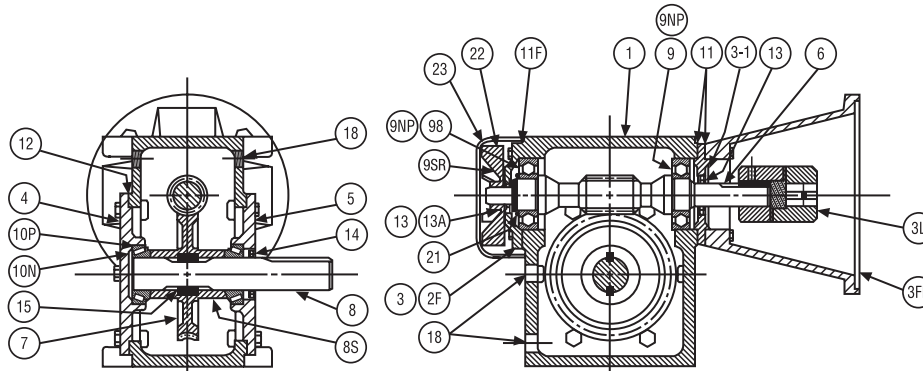

Item No.	Quantity	Description
1	1	Housing
2F	1	Worm gland-open (350-400 only)
3	1	Worm gland-open (500-600 only)
3-1	1	Input gland-open (300-400 only)
3L	1	Complete coupling
3FL	1	NEMA frame motor flange
4	1	Worm gear gland-closed
5	1	Worm gear gland-open
6	1	Worm and shaft integral
7	1	Worm gear-bronze forging
8	1	Worm gear shaft-single proj.
8A	1	Worm gear shaft-double proj. (not shown)
8S	2	Gear shaft spacers
9	1	Input bearing-front (350-400 only)
9B	1	Input bearing-rear (350-400 only)
9N	2	Input shaft-roller bearings (500-600 only)
9P	2	Input shaft bearing cups (500-600 only)

Item No.	Quantity	Description
9SR	1	Input shaft snap ring (350-400 only)
10N	2	Output shaft taper roller bearings
10P	2	Output shaft bearing cups
11	2	Input gland gaskets
11F	2	Input gland gaskets
12	4	Output gear gland gaskets
13	1	Input motor flange oil seal-front (front & rear 500 - 600 only)
13A	1	Input shaft oil seal-rear (350-400 only)
14	1	Output shaft oil seal
15	2	Gear shaft keys
17	1	Vent plug (not shown)
18	6	Oil level and drain plugs
20	1 pr.	Angle feet for SV mtg. (not shown)
21	1	Input shaft-washer
22	1	Fan
23	1	Fan guard

Universal Series Parts Lists

Double Reduction

Styles DBF, DTF & DVF – Sizes 175 through 300

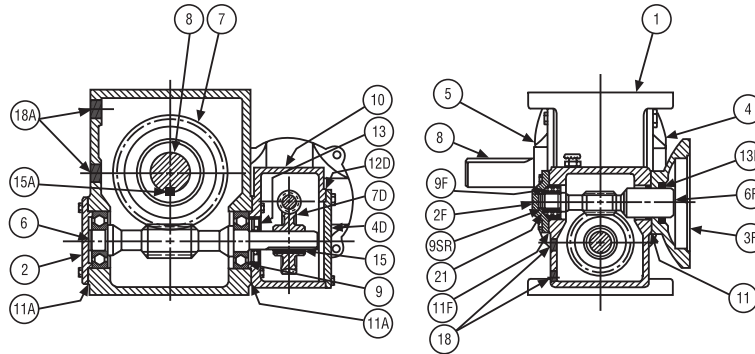

Item No.	Quantity	Description
1	1	Housing-second reduction
1D	1	Housing-first reduction
2	1	Worm gland-closed-second reduction
2F	1	Worm gland-closed-first reduction
3F	1	NEMA frame motor flange-first reduction
4	1	Output gear gland-closed-second reduction
4D	1	Housing cover-first reduction
5	1	Output gear gland-open-second reduction
6	1	Worm and shaft integral-second reduction
6F	1	Worm & shaft integral-first reduction
7	1	Worm gear-bronze forging-second reduction
7D	1	Worm gear bronze forging-first reduction
8	1	Output worm gear shaft-single proj.-second reduction
8A	1	Output worm gear shaft-double proj.-second reduction (not shown)
9	2	Worm shaft ball bearings-second reduction
9F	1	Worm shaft ball bearing-first reduction
9SR	1	Input worm snap ring-first reduction
10N	2	Output shaft taper roller bearing cone-second reduction (not shown)

Item No.	Quantity	Description
10P	2	Output shaft bearing cup-second reduction (not shown)
11	3	Input motor flange gasket-first reduction
11A	4	Worm gland gaskets-second reduction
11F	1	Input gland gasket-first reduction
12	4	Gear gland gaskets-second reduction (not shown)
12D	1	Housing cover gasket-first reduction
13	1	Worm shaft oil seal-second reduction
13F	1	Input motor flange oil seal-first reduction
14	1	Output shaft oil seal-second reduction (not shown)
15	1	Worm gear key-first reduction
15A	1	Worm gear key-second reduction
17	1	Vent plug-first reduction (not shown)
17A	1	Vent plug-second reduction (not shown)
18	6	Oil level and drain plugs-first reduction
18A	6	Oil level and drain plugs-second reduction
20	1 pr.	Angle feet for DVF mtg. (not shown)
21	1	Worm washer-first reduction

Styles DBF, DTF & DVF – Sizes 350 through 600

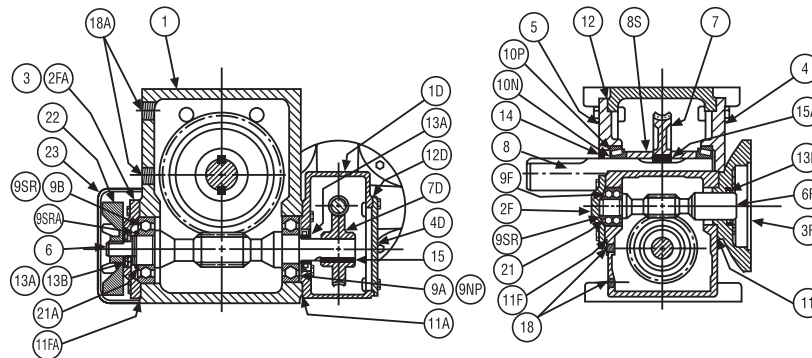

Item No.	Quantity	Description
1	1	Housing-second reduction
1D	1	Housing-first reduction
2F	1	Worm gland-closed-first reduction
2FA	1	Worm gland-open-second reduction (350-400 only)
3	1	Worm gland-open-second reduction (500-600 only)
3F	1	NEMA frame motor flange-first reduction
4	1	Output gear gland-closed-second reduction
4D	1	Housing cover-first reduction
5	1	Output gear gland-open-second reduction
6	1	Worm and shaft integral-second reduction
6F	1	Worm and shaft integral-first reduction
7	1	Worm gear-bronze forging-second reduction
7D	1	Worm gear-bronze forging-first reduction
8	1	Output worm gear shaft-single proj.-
8A	1	Output worm gear shaft-double proj.

Item No.	Quantity	Description
8S	2	Gear shaft spacers-second reduction
9A	2	Worm bearing-front-second reduction
9F	1	Worm shaft bearing-first reduction
9N	2	Worm taper roller bearing cone-
9P	2	Worm bearing cup-second reduction
9SR	1	Worm snap ring-first reduction
9SRA	1	Worm snap ring-second reduction
10N	2	Output shaft taper roller bearing cone
10P	2	Output shaft bearing cups-second reduction
11	1	Input gland gasket-first reduction
11A	4	Worm gland gaskets-second reduction
11FA	1	Worm gland gasket-second reduction
11F	2	Input gland gaskets-first reduction
12	4	Gear gland gaskets-second reduction
12D	1	Housing cover gaskets-first reduction

Item No.	Quantity	Description
13A	1	Worm shaft oil seal-front-second reduction
13B	1	Worm shaft oil seal-rear-second reduction
13F	1	Input motor flange oil seal-first reduction
14	1	Output shaft oil seal-second reduction
15	1	Gear shaft key-first reduction
15A	1	Worm gear key-second reduction
17	1	Vent plug-first reduction (not shown)
17A	1	Vent plug-second reduction (not shown)
18	6	Oil level and drain plugs-first reduction
18A	6	Oil level and drain plugs-second reduction
20	1 pr.	Angle feet for DVF mtg. (not shown)
21	1	Worm washer-first reduction
21A	1	Worm washer-second reduction
22	1	Fan
23	1	Fan guard

H50 Reducer

900 Series Single Reduction

900 Series Double Reduction

Accessories

Ratio Multipliers

In-Line Helical (LH)

Universal Series Single Reduction

Universal Series Double Reduction

Engineering

Universal Series Parts Lists

Double Reduction

STYLES DBL, DTL & DVL SIZES 175 THROUGH 300

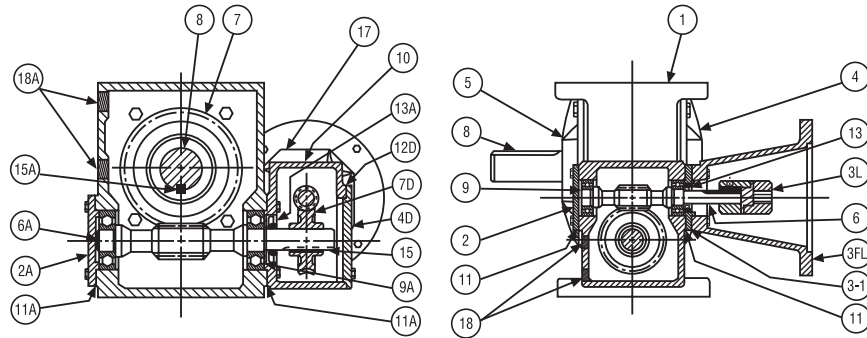

Item No.	Quantity	Description
1	1	Housing-second reduction
1D	1	Housing-first reduction
2	1	Worm gland-closed-first reduction
2A	1	Worm gland-closed-second reduction
3-1	1	Worm gland-open
3L	1	Complete coupling
3FL	1	NEMA frame motor flange-first reduction
4	1	Output gear gland-closed-second reduction
4D	1	Housing cover-first reduction
5	1	Output gear gland-open-second reduction
6	1	Worm and shaft integral-first reduction
6A	1	Worm & shaft integral-second reduction
7	1	Worm gear-bronze forging-second reduction
7D	1	Worm gear-bronze forging-first reduction
8	1	Output worm gear shaft-single proj.-second reduction
8A	1	Output worm gear shaft-double proj.-second reduction (not shown)
9A	2	Worm shaft ball bearings-second reduction
9	2	Worm shaft ball bearing-first reduction

Item No.	Quantity	Description
9	2	Worm shaft ball bearing-first reduction
10N	2	Output shaft taper roller bearing cone-second reduction (not shown)
10P	2	Output shaft bearing cup-second reduction (not shown)
11	2	Input gland gaskets-first reduction
11A	4	Worm gland gaskets-second reduction
12	4	Gear gland gaskets-second reduction (not shown)
12D	1	Housing cover gasket-first reduction
13	1	Input motor flange oil seal-first reduction
13A	1	Worm shaft oil seal-second reduction
14	1	Output shaft oil seal-second reduction (not shown)
15	1	Worm gear key-first reduction
15A	1	Worm gear key-second reduction
17	1	Vent plug-first reduction (not shown)
17A	1	Vent plug-second reduction (not shown)
18	6	Oil level and drain plugs-first reduction
18A	6	Oil level and drain plugs-second reduction
20	1 pr.	Angle feet for DVL mtg. (not shown)

STYLES DBL, DTL & DVL SIZES 350 THROUGH 600

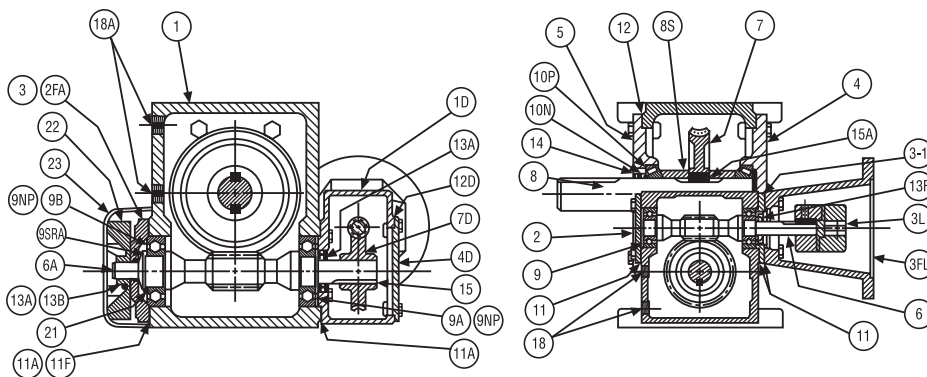

Item No.	Quantity	Description
1	1	Housing-second reduction
1D	1	Housing-first reduction
2	1	Worm gland-closed-first reduction
2FA	1	Worm gland-open-second reduction (350-400 only)
3-1	1	Worm gland-open
3	1	Worm gland-second reduction (500-600 only)
3L	1	Complete coupling
3FL	1	NEMA frame motor flange-first reduction
4	1	Output gear gland-closed-second reduction
4D	1	Housing cover-first reduction
5	1	Output gear gland-open-second reduction
6	1	Worm and shaft integral-first reduction
6A	1	Worm and shaft integral-second reduction
7	1	Worm gear-bronze forging-second reduction
7D	1	Worm gear-bronze forging-first reduction

Item No.	Quantity	Description
8	1	Output worm gear shaft-single proj.-
8A	1	Output worm gear shaft-double proj.-
8S	2	Gear shaft spacers-second reduction
9	2	Worm shaft ball bearing-first reduction
9A	1	Worm bearing-front-second reduction
9B	1	Worm bearing-rear-second reduction
9N	2	Worm taper roller bearing-
9P	2	Worm bearing cup-second reduction
9SRA	1	Worm snap ring-second reduction
10N	2	Output shaft taper roller bearing cone-
10P	2	Output shaft bearing cups-second reduction
11	3	Input gland gaskets-first reduction
11A	1	Worm gland gasket-second reduction
11F	1	Worm gland gasket-second reduction
12	4	Gear gland gaskets-second reduction

Item No.	Quantity	Description
12D	1	Housing cover gasket-first reduction
13A	1	Worm shaft oil seal-front-second reduction
13B	1	Worm shaft oil seal-rear-second reduction
13F	1	Input motor flange oil seal-first reduction
14	1	Output shaft oil seal-second reduction
15	1	Worm gear key-first reduction
15A	2	Worm gear keys-second reduction
17	1	Vent plug-first reduction (not shown)
17A	1	Vent plug-second reduction (not shown)
18	6	Oil level and drain plugs-first reduction
18A	6	Oil level and drain plugs-second reduction
20	1 pr.	Angle feet for DVL mtg. (not shown)
21	1	Worm washer-second reduction
22	1	Fan
23	1	Fan guard

Universal Series Parts Lists

Double Reduction

STYLES WDB, WDT & WDV SIZES 175 THROUGH 300

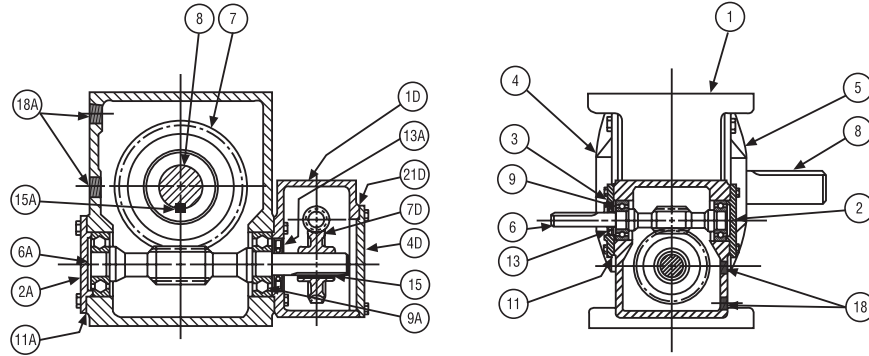

Item No.	Quantity	Description
1	1	Housing-second reduction
1D	1	Housing-first reduction
2	1	Worm gland-closed-first reduction
2A	1	Worm gland-closed-second reduction
3	1	Worm gland-open-first reduction
4	1	Gear gland-closed-second reduction
4D	1	Housing cover-first reduction
5	1	Gear gland-open-second reduction
6	1	Worm and shaft integral-first reduction
6A	1	Worm and shaft integral-second reduction
7	1	Worm gear-bronze forging-second reduction
7D	1	Worm gear-bronze forging-first reduction
8	1	Output gear shaft-single proj.-second reduction
8A	1	Output gear shaft-double proj.-second reduction (not shown)
9	2	Worm shaft ball bearings-first reduction
9A	2	Worm shaft ball bearing-second reduction

Item No.	Quantity	Description
10N	2	Output shaft taper roller bearing cone-second reduction (not shown)
10P	2	Output shaft bearing cups-second reduction (not shown)
11	4	Worm gland gaskets-first reduction
11A	4	Worm gland gaskets-second reduction
12	4	Gear gland gaskets-second reduction (not shown)
12D	1	Housing cover gasket-first reduction
13	1	Worm shaft oil seal-first reduction
13A	1	Worm shaft oil seal-second reduction
14	1	Gear shaft oil seal-second reduction (not shown)
15	1	Gear shaft key-first reduction
15A	1	Gear shaft key-second reduction
17	1	Vent plug-first reduction (not shown)
17A	1	Vent plug-second reduction (not shown)
18	6	Oil level and drain plugs-first reduction
18A	6	Oil level and drain plugs-second reduction
20	1 pr.	Angle feet for WDV mtg. (not shown)

STYLES WDB, WDT & WDV SIZES 350 THROUGH 600

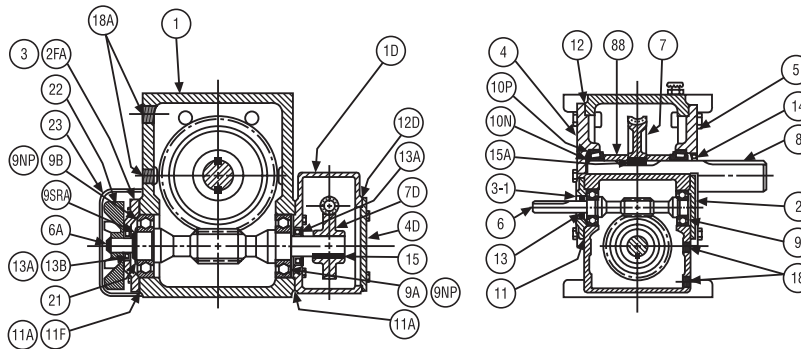

Item No.	Quantity	Description
1	1	Housing-second reduction
1D	1	Housing-first reduction
2	1	Worm gland-closed-first reduction
2FA	1	Worm gland-open-second reduction (350-400 only)
3-1	1	Worm gland-open-first reduction (350-400 only)
3	1	Worm gland-open-second reduction (500-600 only)
4	1	Output gear gland-closed-second reduction
4D	1	Housing cover-first reduction
5	1	Gear gland-open-second reduction
6	1	Worm and shaft integral-first reduction
6A	1	Worm and shaft integral-second reduction
7	1	Worm gear-bronze forging-second reduction
7D	1	Worm gear-bronze forging-first reduction
8	1	Output gear shaft-single proj.-second reduction
8A	1	Output gear shaft-double proj.-second reduction
8S	2	Gear shaft spacers-second reduction
9	2	Worm shaft ball bearings-first reduction

Item No.	Quantity	Description
9A	1	Worm shaft ball bearing-front-second reduction
9B	1	Worm shaft ball bearing-rear-second reduction
9N	2	Worm taper roller bearing cone-
9P	2	Worm bearing cup-second reduction
9SRA	1	Worm shaft snap ring-second reduction
10N	2	Gear shaft taper roller bearing cone-
10P	2	Gear shaft bearing cups-second reduction
11	4	Gland gaskets-first reduction
11A	2	Worm gland gaskets-second reduction
11F	2	Worm gland gaskets-second reduction
12	4	Gear gland gaskets-second reduction
12D	1	Housing cover gasket-first reduction
13	1	Worm shaft oil seal-first reduction
13A	1	Worm shaft oil seal-front-second reduction
13B	1	Worm shaft oil seal-rear-second reduction
14	1	Gear shaft oil seal-second reduction
15	1	Worm gear key-first reduction

Item No.	Quantity	Description
15A	2	Worm gear keys-second reduction
17	1	Vent plug-first reduction (not shown)
17A	1	Vent plug-second reduction (not shown)
18	6	Oil level and drain plugs-first reduction
18A	6	Oil level and drain plugs-second reduction
20	1 pr.	Angle feet for WDV mtg. (not shown)
21	1	Worm shaft washer-second reduction
22	1	Fan
23	1	Fan guard

Ratio Multiplier Parts Lists

MODELS RM1 & RM2

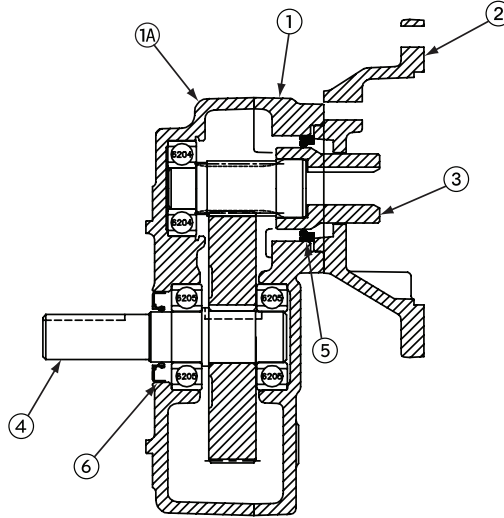

Item No.	Quantity	Description
1	1	Housing Body
1A	1	Housing Cover
2	1	Motor Flange
3	1	Input Shaft / Pinion Assembly
4	1	Output Shaft Assembly
5	1	Input Oil Seal
6	1	Output Oil Seal

H50
Reducer

900 Series
Single Reduction

900 Series
Double Reduction

Accessories

Ratio Multiplier

In-Line Helical (LH)

Universal Series
Single Reduction

Universal Series
Double Reduction

Engineering

Seal Kits

900 SERIES KIT PART NUMBERS

Size	F	S/LF	DA/DB/DC LFDA/LFDB/LFDC	FDA/FDB/FDC	HF	HS/HLF
913	GS5000A13SP	GS5000A01SP	—	—	GS5000A66SP	GS5000A65SP
915	GS5000A59SP	GS5000A60SP	—	—	—	—
918	GS5000A16SP	GS5000A02SP	GS5000A08SP	GS5000A19SP	GS5000A70SP	GS5000A69SP
921	GS5000A12SP	GS5000A05SP	GS5000A011SP	GS5000A22SP	GS5000A72SP	GS5000A71SP
921G	GS5000A75SP	—	—	—	—	—
924	GS5000A15SP	GS5000A04SP	GS5000A09SP	GS5000A20SP	GS5000A74SP	GS5000A73SP
926	GS5000A17SP	GS5000A06SP	GS5000A07SP	GS5000A18SP	GS5000A77SP	GS5000A76SP
930	GS5000A62SP	GS5000A61SP	—	—	GS5000A79SP	GS5000A78SP
932	GS5000A14SP	GS5000A03SP	GS5000A10SP	GS5000A21SP	GS5000A81SP	GS5000A80SP
938	GS5000A63SP	GS5000A64SP	—	—	GS5000A82SP	GS5000A83SP

WD & SS 900 SERIES SEAL KIT PART NUMBERS

Size	WDF	SSF	WDHF	SSHF
913	GS5000A86SP	—	GS5000A106SP	—
915	GS5000A87SP	—	GS5000A107SP	—
918	GS5000A88SP	GS5000A98SP	GS5000A108SP	GS5000A118SP
921	GS5000A89SP	GS5000A99SP	GS5000A109SP	GS5000A119SP
921G	GS5000A90SP	—	GS5000A110SP	—
924	GS5000A91SP	—	GS5000A111SP	—
926	GS5000A92SP	GS5000A102SP	GS5000A112SP	GS5000A122SP
930	GS5000A93SP	—	GS5000A113SP	—
932	GS5000A94SP	GS5000A104SP	GS5000A114SP	GS5000A124SP
938	GS5000A95SP	—	GS5000A115SP	—

UNIVERSAL SERIES KIT PART NUMBERS

Size	ST/SB/SV STL/SVL	STF/SVF	DBF/DTF/DVF	DBL/DTL/DVL WDB/WDT/WDV
133	GS5000A27SP	GS5000A45SP	—	—
175	GS5000A30SP	GS5000A48SP	GS5000A52SP	GS5000A36SP
200	GS5000A24SP	GS5000A42SP	GS5000A56SP	GS5000A38SP
225	GS5000A25SP	GS5000A46SP	GS5000A58SP	GS5000A40SP
258	GS5000A29SP	GS5000A43SP	GS5000A54SP	GS5000A33SP
300	GS5000A32SP	GS5000A49SP	GS5000A50SP	GS5000A34SP
350	GS5000A31SP	GS5000A47SP	GS5000A53SP	GS5000A41SP
400	GS5000A23SP	GS5000A44SP	GS5000A57SP	GS5000A37SP
500	GS5000A26SP	—	GS5000A55SP	GS5000A39SP
600	GS5000A28SP	—	GS5000A51SP	GS5000A35SP

HFO
Reducer

900 Series
Single Reduction

900 Series
Double Reduction

Accessories

Ratio Multipliers

In-Line Helical (LH)

Universal Series
Single Reduction

Universal Series
Double Reduction

Engineering

900 Series Style LF Coupling Part Numbers

	Bore	Manufacturing Number	Baldor Number	Bore	Manufacturing Number	Baldor Number
913B5			913B7			
Motor Coupling Half	0.625	L070-5/8	913-3L070-5	0.875		
Spider		S-070	913-3S070			
Gear Coupling Half	0.500	L070-1/2	913-3L070-4	0.500		
918B5			918B7			
Motor Coupling Half	0.625	L075-5/8	918-3L075-5	0.875	L075-7/8	918-3L075-7
Spider		S-075	918-3S075		S-075	918-3S075
Gear Coupling Half	0.625	L075-5/8	918-3L075-5	0.625	L075-5/8	918-3L075-5
921B5			921B7			
Motor Coupling Half	0.625	L090-5/8	921-3L090-5	0.875	L090-7/8	921-3L090-7
Spider		S-090	921-3S090		S-090	921-3S090
Gear Coupling Half	0.625	L090-5/8	921-3L090-4	0.625	L090-5/8	921-3L090-5

	Bore	Manufacturing Number	Baldor Number	Bore	Manufacturing Number	Baldor Number
924B5			924B7			
Motor Coupling Half	0.625	L090-5/8	918-3L075-5	0.875	L075-7/8	918-3L075-7
Spider		S-090/L-095 SOX-OCT	918-3S075		S-075	918-3S075
Gear Coupling Half	0.625	L075-5/8	918-3L075-5	0.625	L075-5/8	918-3L075-5
926B5			926B7			
Motor Coupling Half	0.625	L095-5/8	926-3L095-5	0.875	L095-7/8	926-3L095-7
Spider		S-090	921-3S090		S-090	921-3S090
Gear Coupling Half	0.750	L095-1/2	926-3L095-6	0.750	L095-3/4	926-3L095-6
932B5			932B7			
Motor Coupling Half	0.625	L099-5/8	932-3L099-5	0.875	L099-7/8	932-3L099-7
Spider		S-099	932-3S099		S-099	932-3S099
Gear Coupling Half	0.875	L099-7/8	932-3L099-7	0.875	L099-7/8	932-3L099-7

H50
Reducer

900 Series
Single Reduction

900 Series
Double Reduction

Accessories

Ratio Multiplier

In-Line Helical (LH)

Universal Series
Single Reduction

Universal Series
Double Reduction

Engineering

Rotary Inertia Conversion Table
(To convert from A to B, multiply by entry in table)

A \ B	gm-cm ²	oz-in ²	gm-cm-s ²	Kg-cm ²	lb-in ²	oz-in-s ²	lb-ft ²	Kg-cm-s ²	lb-in-s	lb-ft-s ² or slug-ft ²
gm-cm ²	1	5.46745 x 10 ⁻³	1.01972 x 10 ⁻³	x 10 ⁻³	3.41716 x 10 ⁻⁴	1.41612 x 10 ⁻⁵	2.37303 x 10 ⁻⁶	1.01972 x 10 ⁻⁶	8.85073 x 10 ⁻⁷	7.37561 x 10 ⁻⁸
oz-in ²	182.901	1	0.186507	0.182901	0.0625	2.59009 x 10 ⁻³	4.34028 x 10 ⁻⁴	1.86507 x 10 ⁻⁴	1.61880 x 10 ⁻⁴	1.34900 x 10 ⁻⁵
gm-cm-s ²	980.665	5.361774	1	0.980665	0.335109	1.38874 x 10 ⁻²	2.32714 x 10 ⁻³	x 10 ⁻³	8.67960 x 10 ⁻⁴	7.23300 x 10 ⁻⁵
Kg-cm ²	1000	5.46745	1.01972	1	0.341716	1.41612 x 10 ⁻²	2.37303 x 10 ⁻³	1.01972 x 10 ⁻³	8.85073 x 10 ⁻⁴	7.37561 x 10 ⁻⁵
lb-in ²	2.92641 x 10 ³	16	2.98411	2.92641	1	4.14414 x 10 ⁻²	6.9444 x 10 ⁻³	2.98411 x 10 ⁻³	2.59009 x 10 ⁻³	2.15840 x 10 ⁻⁴
oz-in-s ²	7.06157 x 10 ⁴	386.088	72.0079	70.6157	24.1305	1	0.167573	7.20079 x 10 ⁻²	6.25 x 10 ⁻²	5.20833 x 10 ⁻³
lb-ft ²	4.21403 x 10 ⁵	2304	429.711	421.403	144	5.96756	1	0.429711	0.372975	3.10810 x 10 ⁻²
Kg-cm-s ²	9.80665 x 10 ⁵	5.36174 x 10 ³	1000	980.665	335.109	13.8874	2.32714	1	0.867960	7.23300 x 10 ⁻²
lb-in-s ²	1.12985 x 10 ⁶	6.17740 x 10 ³	1.15213 x 10 ³	1.12985 x 10 ³	386.088	16	2.68117	1.15213	1	8.33333 x 10 ⁻³
lb-ft-s ² or slug-ft ²	1.35582 x 10 ⁷	7.41289 x 10 ⁴	1.38255 x 10 ⁴	1.35982 x 10 ⁴	4.63305 x 10 ³	192	32.1740	13.8255	12	1

Torque Conversion Table
(To convert from A to B, multiply by entry in table)

A \ B	dyne-cm	gm-cm	oz-in	Kg-cm	lb-in	N-m	lb-ft	Kg-m
dyne-cm	1	1.01972 x 10 ⁻³	1.41612 x 10 ⁻⁵	1.01972 x 10 ⁻⁶	8.85073 x 10 ⁻⁷	x 10 ⁻⁷	7.37561 x 10 ⁻⁸	1.01972 x 10 ⁻⁸
gm-cm	980.665	1	1.38874 x 10 ⁻²	10 ⁻³	8.67960 x 10 ⁻⁴	9.80665 x 10 ⁻⁵	7.23300 x 10 ⁻⁵	x 10 ⁻⁵
oz-in	7.06157 x 10 ⁴	72.0079	1	7.20079 x 10 ⁻²	6.25 x 10 ⁻²	7.06571 x 10 ⁻³	5.20833 x 10 ⁻³	7.20079 x 10 ⁻⁴
Kg-cm	9.80665 x 10 ⁵	1000	13.8874	1	0.867960	9.80665 x 10 ⁻²	7.23300 x 10 ⁻²	x 10 ⁻²
lb-in	1.12985 x 10 ⁶	1.15213 x 10 ³	16	1.15213	1	0.112985	8.33333 x 10 ⁻²	1.15213 x 10 ⁻²
N-m	10 ⁷	1.01972 x 10 ⁴	141.612	10.1972	8.85073	1	0.737561	0.101972
lb-ft	1.35582 x 10 ⁷	1.38255 x 10 ⁴	192	13.8255	12	1.35582	1	0.138255
Kg-m	9.80665 x 10 ⁷	10 ⁵	1.38874 x 10 ³	100	86.7960	9.80665	7.23300	1

H50
Reducer

900 Series
Single Reduction

900 Series
Double Reduction

Accessories

Ratio Multipliers

In-Line Helical (LH)

Universal Series
Single Reduction

Universal Series
Double Reduction

Engineering

Length Conversion Table
(To convert from A to B, multiply by entry in table)

A \ B	Inches	Feet	Millimeter	Centimeter	Meter	Kilometer
Inches (In)	1	8.334×10^{-2}	25.4	2.54	2.54×10^{-2}	2.54×10^{-5}
Feet (Ft)	12	1	304.8	30.48	0.3048	3.048×10^{-4}
Millimeter (MM)	3.93×10^{-2}	3.281×10^{-3}	1	0.1	1×10^{-3}	1×10^{-6}
Centimeter (CM)	.3937	3.281×10^{-2}	10	1	1×10^{-2}	1×10^{-5}
Meter (M)	39.37	3.281	1000	100	1	1×10^{-3}
Kilometer (KM)	3.9×10^4	3281	1×10^6	1×10^5	1000	1

Power Conversion Table
(To convert from A to B, multiply by entry in table)

A \ B	Watts	Kilowatts	HP	BTU/Min	Ft-Lbs/Min	Metric HP
Watts	1	1×10^{-3}	1.341×10^{-3}	5.68×10^{-2}	44.27	1.36×10^{-3}
Kilowatts	1000	1	1.341	56.8	4.42×10^4	1.36
Horsepower (HP)	745.7	0.7457	1	42.44	3.3×10^4	1.014
BTU/Min	17.57	1.757×10^{-2}	2.356×10^{-2}	1	777.6	2.38×10^{-2}
Ft-Lbs/Min	2.25×10^{-3}	2.26×10^{-5}	3.03×10^{-5}	1.286×10^{-3}	1	3.09×10^{-5}
Metric HP	735.2	0.7352	0.9863	41.84	3.25×10^3	1

Rotation Conversion Table
(To convert from A to B, multiply by entry in table)

A \ B	RPM	Radian/Second	Degree/Second	Revolution/Second
Revolution/Minute	1	0.1047	6	1.667×10^{-2}
Radian/Second	9.549	1	57.296	0.1592
Degrees/Second	0.1667	1.745×10^{-2}	1	2.778×10^{-3}
Revolution/Second	60	6.283	360	1

Mass Conversion Table
(To convert from A to B, multiply by entry in table)

A \ B	Ounce	Pound	Slug	Gram	Kilogram	Metric Ton
Ounce (OZ)	1	6.25×10^{-2}	1.943×10^3	28.349	28.349	28.34×10^{-6}
Pound (LB)	16	1	3.108×10^{-2}	453.6	0.4536	4.536×10^{-4}
Slug	514.7	32.17	1	1.459×10^4	14.59	14.59×10^{-3}
Gram (GM)	3.527×10^{-2}	2.205×10^{-3}	6.853×10^{-5}	1	1×10^{-3}	1×10^{-6}
Kilogram (KGM)	35.27	2.2046	6.853×10^{-2}	1000	1	1×10^{-3}
Metric Ton	3.527×10^4	2.2046×10^3	68.53	1×10^6	1000	1

Limited Warranty

Baldor Electric Company and its employees are proud of our products and are committed to providing our customers and end users with the best designed and manufactured motors, drives and other Baldor products. This Limited Warranty and Service Policy describes Baldor's warranty and warranty procedures.

Comments and Questions: We welcome comments and questions regarding our products. Please contact us at:

Customer Service
Baldor Electric Company
P. O. Box 2400
Fort Smith, Arkansas 72902
Telephone: (479) 646-4711
Facsimile: (479) 648-5792

Scope of Warranty: All Baldor standard motors are warranted against defects in Baldor workmanship and materials.

Warranty Period: Most Baldor motors and gear reducers are warranted for 18 months from the date of shipment to Baldor's customer from Baldor's district warehouse, or, if applicable, from Baldor's factory. Baldor Standard-E™ standard efficient motors are warranted for 24 months. Baldor Super-E® premium efficiency motors are warranted for 36 months. Baldor control products are warranted for 24 months. All warranty claims must be submitted to a Baldor Service Center prior to the expiration of the warranty period.

Warranty Service Center Locations: Warranty service is available for all Baldor products from Baldor's Customer Service Center in Fort Smith, Arkansas, and from Baldor Authorized Service Centers. A list of Baldor's Authorized Service Centers is available in catalog #505 from any Baldor District Office or by contacting us at the above location.

Procedure to Receive Warranty Service: Customers should take or ship prepaid the Baldor product requiring warranty service to a Baldor Authorized Service Center. Please include an explanation of the defect or problem, a description of the way in which the Baldor product is used, and your name, address and telephone number.

Repair by Other than a Baldor-Authorized Service Center: Customers who are unable to take or ship the Baldor product to a Baldor Authorized Service Center, or who desire a repair to be made by other than a Baldor Authorized Service Center, should contact the local Baldor District Office. A repair by anyone other than a Baldor Authorized Service Center must be approved in advance by Baldor.

Repairs or Replacement Within the Scope of the Warranty: If a Baldor product is defective due to Baldor workmanship or materials and the defect occurs during the warranty period, then Baldor will either repair the product or replace it with a new one, whichever Baldor believes to be appropriate under the circumstances. Baldor is not responsible for removal and shipping of the Baldor product to the service center, the reinstallation of the Baldor product upon its return to the customer, or any incidental or consequential damages resulting from the defect, removal reinstallation, shipment or otherwise.

Repairs Outside the Scope of the Warranty: Problems with Baldor products can be due to improper maintenance, faulty installation, non-Baldor additions or modifications, or other problems not due to defects in Baldor workmanship or materials. If the Baldor Authorized Service Center determines that the problem with a Baldor product is not due to defects in Baldor workmanship or materials, then the customer will be responsible for the cost of any necessary repairs. Customers not satisfied with a determination that a problem is outside of warranty coverage should contact the Baldor District Office for further consideration.

Intended Use: Baldor products are designed for industrial, commercial and agricultural use rather than household, family or personal use.

Product Specifications: All product specifications, applications and other information provided in Baldor's catalog and publications are subject to correction and change without notice and should be confirmed with the Baldor District Office prior to ordering.

Extended Warranties: Extended warranties are available for certain Baldor products. These warranties are described in Baldor's catalog and other sales literature. Extended warranties are subject to the terms and procedures of this Limited Warranty and Service Policy as modified by the additional terms of the extended warranty.

No Other Warranties and Liability Limitation: This Limited Warranty and Service Policy represents Baldor's sole and exclusive warranty obligation with respect to Baldor products. Baldor's liability to a customer or any other person shall not exceed the Baldor's sales price of the applicable Baldor product. BALDOR DISCLAIMS ALL OTHER EXPRESS AND IMPLIED WARRANTIES INCLUDING THE IMPLIED WARRANTIES OF FITNESS FOR A PARTICULAR PURPOSE AND MERCHANTABILITY.

Trademark Notice

BALDOR®, BALDOR MOTORS AND DRIVES®, BALDOR SUPER-E®, BIG RED®, DIRTY DUTY®, INVERTER DRIVE®, MOD EXPRESS®, VALUE FORMULA®, and VECTOR DRIVE®, and associated designs are registered trademarks of Baldor Electric Company. BALDOR SMARTMOTOR, ISR, INVERTER SPIKE RESISTANT, MATCHED PERFORMANCE, and WASHDOWN DUTY, and associated designs are trademarks of Baldor Electric Company.

Baldor has made every effort to make this catalog complete and accurate as of the time of printing. Since products are continuously being improved, all data is subject to change or correction. The data presented here is for general information to provide an overview of Baldor's capabilities. For specific applications, installation and operating instructions, certified dimensions, capabilities and performance data, and pricing and availability, contact your Baldor District Sales Office listed on the inside back cover.

© 2004 Baldor Electric Company.

BALDOR SALES OFFICES



UNITED STATES

ARIZONA

PHOENIX
4211 S 43RD PLACE
PHOENIX, AZ 85040
PHONE: 602-470-0407
FAX: 602-470-0464

ARKANSAS

CLARKSVILLE
706 WEST MAIN STREET
CLARKSVILLE, AR 72830
PHONE: 479-754-9108
FAX: 479-754-9205

CALIFORNIA

LOS ANGELES
6480 FLOTILLA STREET
COMMERCE, CA 90040
PHONE: 323-724-6771
FAX: 323-721-5859

HAYWARD

21056 FORBES STREET
HAYWARD, CA 94545
PHONE: 510-785-9900
FAX: 510-785-9910

COLORADO

DENVER
3855 FOREST STREET
DENVER, CO 80207
PHONE: 303-623-0127
FAX: 303-595-3772

CONNECTICUT

WALLINGFORD
65 SOUTH TURNPIKE ROAD
WALLINGFORD, CT 06492
PHONE: 203-269-1354
FAX: 203-269-5485

FLORIDA

**TAMPA/PUERTO RICO/
VIRGIN ISLANDS**
3906 EAST 11TH AVENUE
TAMPA, FL 33605
PHONE: 813-248-5078
FAX: 813-241-9514

GEORGIA

ATLANTA
62 TECHNOLOGY DRIVE
ALPHARETTA, GA 30005
PHONE: 770-772-7000
FAX: 770-772-7200

ILLINOIS

CHICAGO
340 REMINGTON BLVD.
BOLINGBROOK, IL 60440
PHONE: 630-296-1400
FAX: 630-226-9420

INDIANA

INDIANAPOLIS
5525 W. MINNESOTA STREET
INDIANAPOLIS, IN 46241
PHONE: 317-246-5100
FAX: 317-246-5110

IOWA

DES MOINES
1943 HULL AVENUE
DES MOINES, IA 50313
PHONE: 515-263-6929
FAX: 515-263-6515

MARYLAND

BALTIMORE
7071A DORSEY RUN RD
ELKCRIDGE, MD 21075
PHONE: 410-579-2135
FAX: 410-579-2677

MASSACHUSETTS

BOSTON
6 PULLMAN STREET
WORCESTER, MA 01606
PHONE: 508-854-0708
FAX: 508-854-0291

MICHIGAN

DETROIT
5993 PROGRESS DRIVE
STERLING HEIGHTS, MI 48312
PHONE: 586-978-9800
FAX: 586-978-9969

MINNESOTA

MINNEAPOLIS
13098 GEORGE WEBER DR, SUITE 400
ROGERS, MN 55374
PHONE: 763-428-3633
FAX: 763-428-4551

MISSOURI

ST LOUIS
13678 LAKEFRONT DRIVE
EARTH CITY, MO 63045
PHONE: 314-373-3032
FAX: 314-373-3038

KANSAS CITY

9810 INDUSTRIAL BLVD.
LENEXA, KS 66215
PHONE: 816-587-0272
FAX: 816-587-3735

NEW YORK

AUBURN
ONE ELLIS DRIVE
AUBURN, NY 13021
PHONE: 315-255-3403
FAX: 315-253-9923

NORTH CAROLINA

GREENSBORO
1220 ROTHERWOOD ROAD
GREENSBORO, NC 27406
PHONE: 336-272-6104
FAX: 336-273-6628

OHIO

CINCINNATI
2929 CRESCENTVILLE ROAD
WEST CHESTER, OH 45069
PHONE: 513-771-2600
FAX: 513-772-2219

CLEVELAND

8929 FREEWAY DRIVE
MACEDONIA, OH 44056
PHONE: 330-468-4777
FAX: 330-468-4778

OKLAHOMA

TULSA
9925 EAST ADMIRAL PLACE
TULSA, OK 74116
PHONE: 918-366-9320
FAX: 918-366-9338

OREGON

PORTLAND
16201 SE 98TH AVENUE
CLACKAMAS, OR 97015
PHONE: 503-691-9010
FAX: 503-691-9012

PENNSYLVANIA

PHILADELPHIA
103 CENTRAL AVENUE, SUITE 400B
MOUNT LAUREL, NJ 08054
PHONE: 856-840-8011
FAX: 856-840-0811

PITTSBURGH

159 PROMINENCE DRIVE
NEW KENSINGTON, PA 15068
PHONE: 724-889-0092
FAX: 724-889-0094

TENNESSEE

MEMPHIS
4000 WINCHESTER ROAD
MEMPHIS, TN 38118
PHONE: 901-365-2020
FAX: 901-365-3914

TEXAS

DALLAS
2920 114TH STREET SUITE 100
GRAND PRAIRIE, TX 75050
PHONE: 214-634-7271
FAX: 214-634-8874

HOUSTON

10355 W. LITTLE YORK ROAD
SUITE 300
HOUSTON, TX 77041
PHONE: 281-977-6500
FAX: 281-977-6510

UTAH

SALT LAKE CITY
2230 SOUTH MAIN STREET
SALT LAKE CITY, UT 84115
PHONE: 801-832-0127
FAX: 801-832-8911

WISCONSIN

MILWAUKEE
1960 SOUTH CALHOUN ROAD
NEW BERLIN, WI 53151
PHONE: 262-784-5940
FAX: 262-784-1215

INTERNATIONAL SALES

FORT SMITH, AR
P.O. BOX 2400
FORT SMITH, AR 72902
PHONE: 479-646-4711
FAX: 479-648-5895

BALDOR
A MEMBER OF THE ABB GROUP

Baldor Electric Company • P.O. Box 2400 • Fort Smith, AR 72902-2400 U.S.A.
Ph: (479) 646-4711 • www.baldor.com